

# K2

## COMBI

### **NEW** High Efficiency Gas Fired, Stainless Steel, Condensing Combi Boiler

**US**

UNMATCHED  
ANYWHERE

#### VALUE-PRICED WITH PREMIUM FEATURES

- 95% AFUE with **10:1** turndown – **NEW!**
- Reliable, proven stainless steel heat exchanger technology
- Flat plate heat exchanger provides superb domestic hot water performance
- Factory pre-set Sage2.3™ Control System, providing out-of-the-box high performance
- Touch screen diagnostic display with plain-language guidance
- FREE 5-year parts warranty included
- Low NOx\*



**US**

UNMATCHED  
ANYWHERE

#### EXTRA BUILT-IN FEATURES

- Universal boiler vent connection for polypropylene, CPVC/PVC, & flexible stainless steel
- Outdoor reset and sensor
- Pre-installed safety relief valve piping

\*Meets requirements of South Coast Rule 1146.2



**Burnham**  
by  
**U.S. Boiler Company**

MADE IN U.S.A.

# K2 Combi: Technical Information



## Standard Equipment

- Direct vent, 10:1 turndown, sealed combustion appliance
- Stainless steel heat exchanger
- Pre-installed circulator and DHW 3-way valve
- DHW flat plate heat exchanger inside jacket
- Sage2.3 Control System
  - LCD touch screen display
  - Self-guided control menus
  - Built-in self diagnostics
  - Additional circulator output available
  - Outdoor reset including outside sensor
  - DHW priority
  - Warm weather shutdown
- Variable speed combustion blower
- Gas valve
- Polypropylene condensate trap
- Flow switch, pre-installed
- Supply, return, & auto reset high limit water sensors
- Universal exhaust vent connection (CPVC/PVC, PP, SS)
- Flue gas temp. sensor & differential pressure switch
- Pre-installed hanging bracket and wall mount kit

## K2 Combi Ratings & Specifications

Model	Energy Star AFUE %	Heating Input (MBH) min-max	DOE Heating Capacity (MBH)	Net AHRI (MBH)	DHW Rates			Vent Size (In.)	Net Wt. (lbs.)
					at 70° TR (GPM)	at 77° TR (GPM)	Input (MBH) min-max		
K2WTC-135B	95.0	12-120	112	97	3.3	3.0	12-135	3	109
K2WTC-180B	95.0	18-180	169	147	4.5	4.1	18-180	3	126

Safety Relief Valve Pressure, Water – 30 PSI std. ASME certified "H". Maximum Allowable Working Pressure at 30 PSI. Max allowable temperature setting 210°F. Target setpoint is 180°F, manual reset high limit setpoint is 210°F. Boilers shipped set for natural gas. Above performance is for elevations to 2000'. Consult Installation, Operating, and Service Instructions for installations up to 10,100' and for additional important notes and details.

## Optional Equipment:

- Natural gas; LP conversion kit for elevations to 2000' sold separately: (135B P/N: 107874-01, 180B P/N: 107875-01)
- Sage Zone Control (Circulator Panel P/N: 104590-01) (Valve Panel P/N 104589-01)
- Service parts kit (P/N: 106260-03)
- Kit, CPVC starter and PVC vent terminations (3" P/N: 107039-02)

## Typical Venting Configurations (Horizontal and Vertical—up to 135 eq.ft.)

Illustrations are for representation only. For complete venting information, please see Installation, Operating, and Service Instructions.



Horizontal 2-pipe

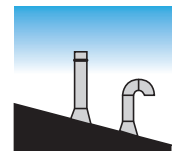

Vertical 2-pipe



Horizontal 2-pipe low profile

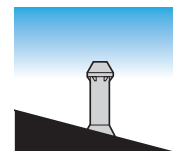

Vertical 2-pipe concentric



Horizontal 2-pipe concentric

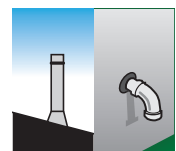

Hybrid

Vertical exhaust/sealed B-vent for combustion air

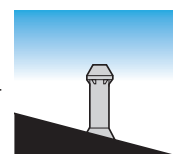

**PLUS polypropylene & stainless steel chimney chase options**

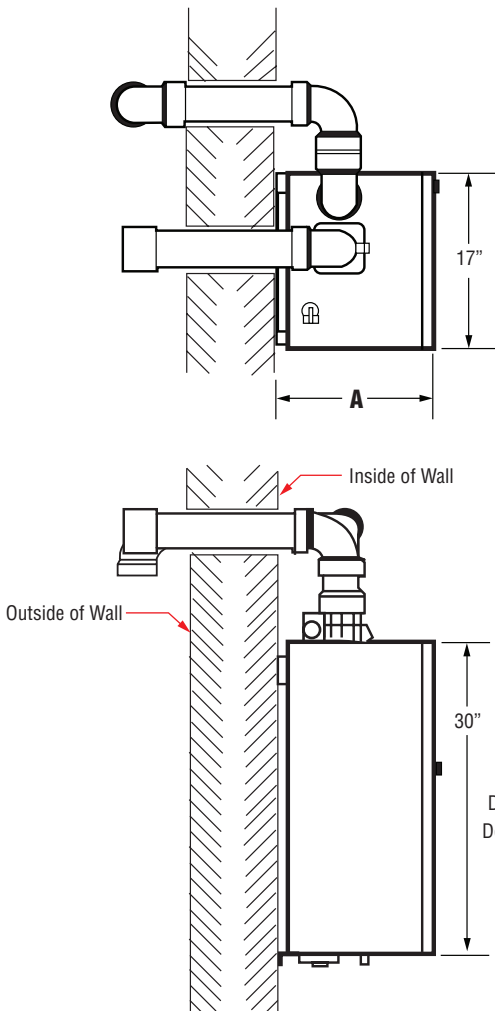

Model(s)	"A" dimension
K2WTC-135B	15"
K2WTC-180B	19"

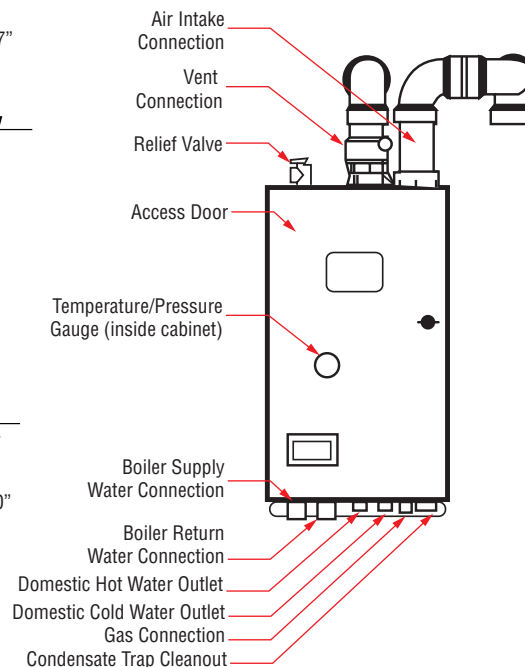

[www.usboiler.net](http://www.usboiler.net)

© 2018 U.S. Boiler Company, Inc.  
Lancaster, PA  
Phone: 1-888-432-8887