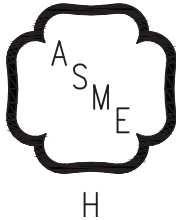


Installation, Operating and Service Instructions for

# K2WTC

## Residential

- Condensing
- High Efficiency
- Direct Vent
- Gas-Fired
- Water Boiler



### Models:

- K2WTC - 135
- K2WTC - 150
- K2WTC - 180

As an ENERGY STAR® Partner, U.S. Boiler Company has determined that the K2WTC Series meets the ENERGY STAR® guidelines for energy efficiency established by the United States Environmental Protection Agency (EPA).



### TO THE INSTALLER:

Affix these instructions adjacent to boiler.

### TO THE CONSUMER:

Retain these instructions for future reference.



**⚠ WARNING!** Improper installation, adjustment, alteration, service or maintenance can cause property damage, injury, or loss of life. For assistance or additional information, consult a qualified installer, service agency or the gas supplier. This boiler requires a special venting system. Read these instructions carefully before installing.

---

## IMPORTANT INFORMATION - READ CAREFULLY

---

NOTE: The equipment shall be installed in accordance with those installation regulations enforced in the area where the installation is to be made. These regulations shall be carefully followed in all cases. Authorities having jurisdiction shall be consulted before installations are made.


All wiring on boilers installed in the USA shall be made in accordance with the National Electrical Code and/or local regulations.


All wiring on boilers installed in Canada shall be made in accordance with the Canadian Electrical Code and/or local regulations.


The City of New York requires a Licensed Master Plumber supervise the installation of this product.

The Commonwealth of Massachusetts requires this product to be installed by a Licensed Plumber or Gas Fitter.


The following terms are used throughout this manual to bring attention to the presence of hazards of various risk levels, or to important information concerning product life.

 **DANGER** Indicates an imminently hazardous situation which, if not avoided, will result in death, serious injury or substantial property damage.


 **CAUTION** Indicates a potentially hazardous situation which, if not avoided, may result in moderate or minor injury or property damage.

 **WARNING** Indicates a potentially hazardous situation which, if not avoided, could result in death, serious injury or substantial property damage.

**NOTICE** Indicates special instructions on installation, operation, or maintenance which are important but not related to personal injury hazards.

 **DANGER** Explosion Hazard. DO NOT store or use gasoline or other flammable vapors or liquids in the vicinity of this or any other appliance.

If you smell gas vapors, DO NOT try to operate any appliance - DO NOT touch any electrical switch or use any phone in the building. Immediately, call the gas supplier from a remotely located phone. Follow the gas supplier's instructions or if the supplier is unavailable, contact the fire department.

 **WARNING** This boiler must only be serviced and repaired by skilled and experienced service technicians. If any controls are replaced, they must be replaced with identical models.

Read, understand and follow all the instructions and warnings contained in all the sections of this manual.

If any electrical wires are disconnected during service, clearly label the wires and assure that the wires are reconnected properly.

Never jump out or bypass any safety or operating control or component of this boiler.

Assure that all safety and operating controls and components are operating properly before placing the boiler back in service.

Annually inspect all vent gaskets and replace any exhibiting damage or deterioration.



**Asphyxiation Hazard. Fire Hazard. Explosion Hazard.** This boiler requires regular maintenance and service to operate safely. Follow the instructions contained in this manual.

Improper installation, adjustment, alteration, service or maintenance can cause property damage, personal injury or loss of life. Read and understand the entire manual before attempting installation, start-up operation, or service. Installation and service must be performed only by an experienced, skilled, and knowledgeable installer or service agency.

This boiler must be properly vented.

This boiler needs fresh air for safe operation and must be installed so there are provisions for adequate combustion and ventilation air.

**Asphyxiation Hazard.** The interior of the venting system must be inspected and cleaned before the start of the heating season and should be inspected periodically throughout the heating season for any obstructions. A clean and unobstructed venting system is necessary to allow noxious fumes that could cause injury or loss of life to vent safely and will contribute toward maintaining the boiler's efficiency.

Installation is not complete unless a safety relief valve is installed in the supply piping. - See the System Piping Section of this manual for details.

This boiler is supplied with safety devices which may cause the boiler to shut down and not re-start without service. If damage due to frozen pipes is a possibility, the heating system should not be left unattended in cold weather; or appropriate safeguards and alarms should be installed on the heating system to prevent damage if the boiler is inoperative.

**Burn Hazard.** This boiler contains very hot water under high pressure. Do not unscrew any pipe fittings nor attempt to disconnect any components of this boiler without positively assuring the water is cool and has no pressure. Always wear protective clothing and equipment when installing, starting up or servicing this boiler to prevent scald injuries. Do not rely on the pressure and temperature gauges to determine the temperature and pressure of the boiler. This boiler contains components which become very hot when the boiler is operating. Do not touch any components unless they are cool.

**Respiratory Hazard.** Boiler materials of construction, products of combustion and the fuel contain alumina, silica, heavy metals, carbon monoxide, nitrogen oxides, aldehydes and/or other toxic or harmful substances which can cause death or serious injury and which are known to the state of California to cause cancer, birth defects and other reproductive harm. Always use proper safety clothing, respirators and equipment when servicing or working nearby the appliance.

Failure to follow all instructions in the proper order can cause personal injury or death. Read all instructions, including all those contained in component manufacturers manuals which are provided with the boiler before installing, starting up, operating, maintaining or servicing.

All cover plates, enclosures and guards must be in place at all times.



**Explosion Hazard. Electrical Shock Hazard. Burn Hazard.** This boiler uses flammable gas, high voltage electricity, moving parts, and very hot water under high pressure. Assure that all gas and electric power supplies are off and that the water temperature is cool before attempting any disassembly or service.

Do not attempt any service work if gas is present in the air in the vicinity of the boiler. Never modify, remove or tamper with any control device.



## WARNINGS FOR THE HOMEOWNER

FOLLOW ALL INSTRUCTIONS and warnings printed in this manual and posted on the boiler.

INSPECT THE BOILER ANNUALLY. To keep your boiler safe and efficient, have a service technician follow the Service checklist near the end of this manual.

IF YOU ARE NOT QUALIFIED to install or service boilers, do not install or service this one.

THE BOILER MAY LEAK WATER at the end of its useful life. Be sure to protect walls, carpets, and valuables from water that could leak from the boiler.

PROTECT YOUR HOME IN FREEZING WEATHER. A power outage, safety lockout, or component failure will prevent your boiler from lighting. In winter, your pipes may freeze and cause extensive property damage. Do not leave the heating system unattended during cold weather unless alarms or other safeguards are in place to prevent such damage

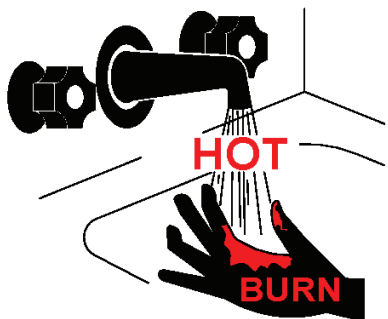
DO NOT BLOCK AIR FLOW into or around the boiler. Insufficient air may cause the boiler to produce carbon monoxide or start a fire.

KEEP FLAMMABLE LIQUIDS AWAY from the boiler, including paint, solvents, and gasoline. The boiler may ignite the vapors from the liquids causing explosion or fire.

KEEP CHILDREN AND PETS away from hot surfaces of the boiler, boiler piping, vent piping and vent terminals.

CARBON MONOXIDE (CO) is an odorless, deadly gas that may be introduced into your home by any malfunctioning fuel-burning product or vent system failure. Consider installing CO alarms near bedrooms in all levels of the building to warn you and your family of potential CO exposure.

### DANGER



- **Water temperature over 125°F (52°C) can cause severe burns instantly or death from scalds.**
- **Children, disabled and elderly are at highest risk of being scalded.**
- **Feel water before bathing or showering.**
- **Installation of an ASSE 1017 or ASSE 1070 certified tempering valve is REQUIRED as part of this boiler's installation. Consult Sections X and XIII for details on valve installation and temperature adjustment.**





## WARNINGS FOR THE INSTALLER

READ THIS ENTIRE MANUAL before attempting installation, start-up, or service. Improper installation, adjustment, alteration, service, or maintenance may cause serious property damage, personal injury, or death.

DO NOT DISCONNECT PIPE FITTINGS on the boiler or in the heating system without first verifying that the system is cool and free of pressure and that your clothing will protect you from a release of hot water or steam. Do not rely solely on the boiler's temperature and pressure gage when making this judgment.

USE PROPER PERSONAL PROTECTION EQUIPMENT when servicing or working near the boiler. Materials of construction, flue products, and fuel contain alumina, silica, heavy metals, carbon monoxide, nitrogen oxides, and/or other toxic or harmful substances that can be hazardous to health and life and that are known to the State of California to cause cancer, birth defects, and other reproductive harm.

INSTALL ALL GUARDS, cover plates, and enclosures before operating the boiler.

SIZE THE BOILER PROPERLY relative to the design heat load or, if using domestic hot water priority, the peak hot water load, whichever is larger. A grossly oversized boiler will cycle excessively and this will lead to premature failure of the boiler and its components. Our warranty does not apply to damage from excessive cycling.

ADHERE TO ALL LOCAL CODE REQUIREMENTS. Contact your local code inspector prior to installation. In the absence of a local code, adhere to the National Fuel Gas Code ANSI Z223.1/NFPA 54 or CAN/CSA B149.1, Natural Gas and Propane Installation Code.

ALL WIRING must comply with the National Electrical Code ANSI/NFPA 70 (in the USA) or the Canadian Electrical Code CSA C22.1 (in Canada) and any local regulations.

---

## Table of Contents

---

I. Product Description . . . . .	7
II. Specifications . . . . .	7
III. Before Installing . . . . .	8
IV. Locating The Boiler . . . . .	9
V. Mounting The Boiler . . . . .	11
VI. Air For Ventilation . . . . .	14
VII. Venting . . . . .	15
A. Vent System Design . . . . .	15
B. Design Requirements Unique to Horizontal Twin Pipe Venting Systems . . . . .	22
C. Design Requirements Unique to Vertical Venting Systems . . . . .	28
D. Design Requirements Unique to Split Vent Systems . . . . .	36
E. Assembly of CPVC/PVC Vent Systems . . . . .	44
F. Assembly of DuraVent PolyPro Vent Systems . . . . .	51
G. Assembly of Selkirk PolyFlue Vent Systems . . . . .	56
H. Assembly of Centrotherm InnoFlue Vent Systems . . . . .	60
I. Assembly of Stainless Steel Vent Systems . . . . .	64
J. Condensate Trap and Drain . . . . .	66
K. Removing An Existing Boiler From Common Chimney . . . . .	67
VIII. Gas Piping . . . . .	68
IX. System Piping . . . . .	70
A. General System Piping Precaution . . . . .	70
B. Standard Piping Installation Requirements . . . . .	71
C. Near Boiler Piping Design . . . . .	73
D. Piping For Special Situations . . . . .	79
X. Domestic Hot Water Piping . . . . .	80
XI. Wiring . . . . .	82
XII. Start-up and Checkout . . . . .	94
XIII. Operation . . . . .	102
XIV. Service and Maintenance . . . . .	125
XV. Troubleshooting . . . . .	132
XVI. Repair Parts . . . . .	141
Appendix A: Instruction for High Altitude Installation Above 2,000 ft. . . . .	154
Appendix B: Special Requirements For Side-Wall Vented Appliances In The Commonwealth of Massachusetts . . . . .	157

## I. Product Description

This boiler is a stainless steel gas fired condensing boiler designed for use in forced hot water heating systems requiring supply water temperatures of 180°F or less. In addition to providing water for space heat, this boiler also generates domestic hot water (DHW). This boiler may be vented vertically or horizontally with combustion air supplied from outdoors. It is not designed for use in gravity hot water systems or systems containing significant amounts of dissolved oxygen.

## II. Specifications

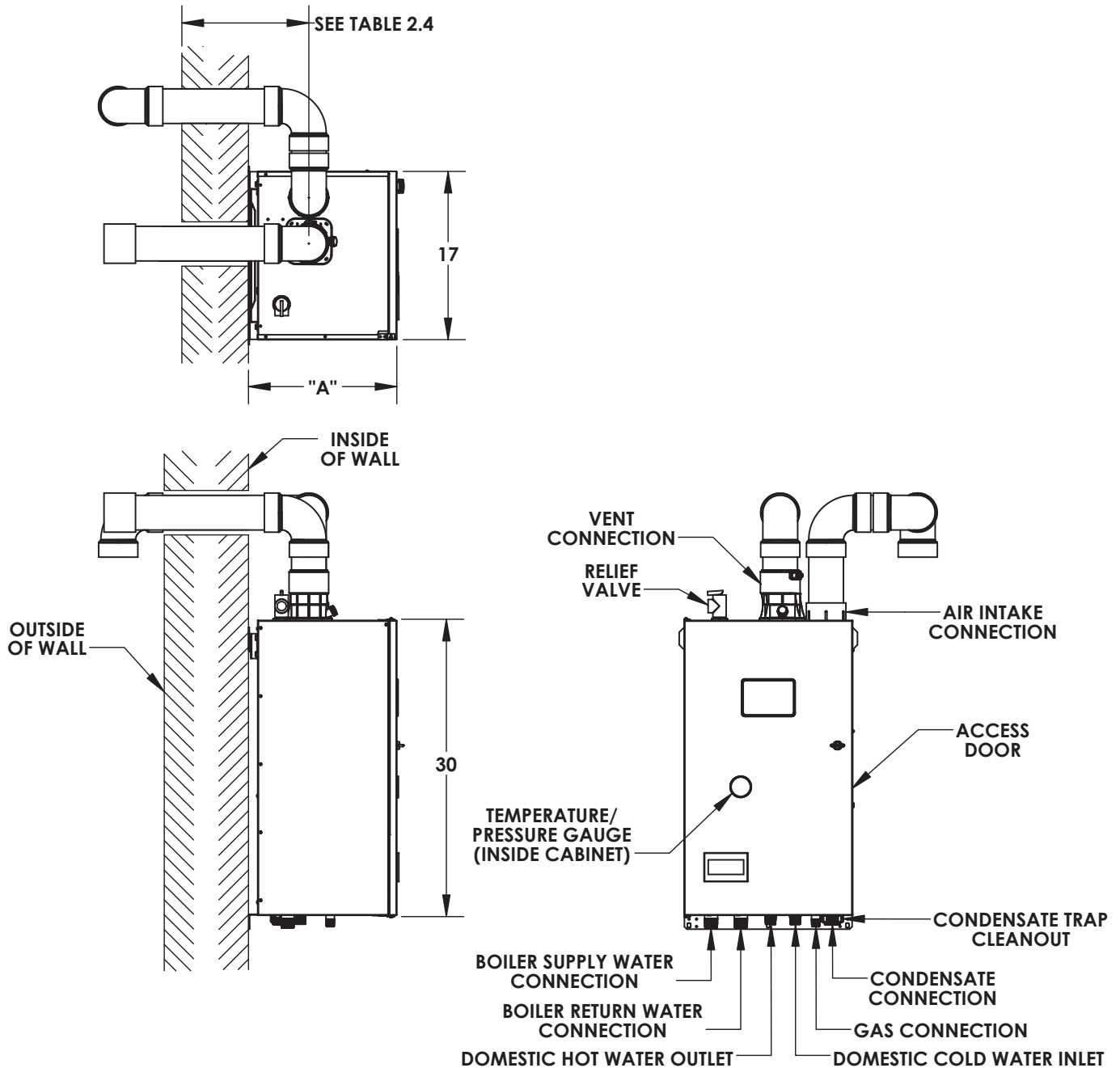


Figure 2.1: General Configuration

## II. Specifications (continued)

**Table 2.2: Performance Specifications**

K2WTC Space Heating Ratings						Domestic Hot Water (DHW) Ratings <sup>1</sup>					
						Input, MBH		Hot Water Draw Limits, GPM			
Model Number	Input, MBH		Heating Capacity, MBH <sup>2</sup>	Net AHRI Water, MBH	AFUE, %	Max. <sup>3</sup>			Min. <sup>4</sup>		
	Min	Max				70°F Rise	77°F Rise	90°F Rise			
K2WTC-135B	12	120	112	97	95.0	12	135	3.3	3.0	2.6	0.5
K2WTC-150B	15	150	142	123	95.0	15	150	3.9	3.7	3.1	0.5
K2WTC-180B	18	180	169	147	95.0	18	180	4.5	4.1	3.5	0.5

Notes:

- DHW ratings are not AHRI certified.
- The Net AHRI Water Ratings shown are based on a piping and pickup allowance of 1.15. The manufacturer should be consulted before selecting a boiler for installations having unusual piping and pickup requirements, such as intermittent system operation, extensive piping systems, etc.
- Maximum draw rates shown are at sea level and minimum vent length. Under other conditions draw rates will be reduced proportionally to the reduction in input. See Table 2.4 and Appendix A for input de-rate information.
- Minimum flow rate shown is that required through the boiler to initiate a call for DHW. A higher flow rate may be required through the fixture due to mixing at the tempering valve and fixture itself.

**Table 2.3: Physical Specifications**

Model Size	Fig 2.1 Dim "A", (in)	Connection Size (NPT Male)			Boiler Water Content, (Gal.)	Net Weight, (lbs.)
		Supply/Return	Hot/Cold	Gas		
135	15	1	3/4	1/2	0.53	109
150	19	1	3/4	1/2	0.79	126
180	19	1	3/4	1/2	0.79	126

**Table 2.4: Vent Lengths**

Model Size	Nominal Vent/Intake Size (in.)	Min. Vent Length (in.)	Max Vent Length (ft.)	Approx. Derate at Max Vent (%)
135	3	12	135	7
150	3	52	135	7
180	3	52	135	9

## III. Before Installing

- Safe, reliable operation of this boiler depends upon installation by a professional heating contractor in strict accordance with this manual and the requirements of the authority having jurisdiction.
  - In the absence of an authority having jurisdiction, installation must be in accordance with this manual and the National Fuel Gas Code, ANSI Z223.1. In Canada, installation must be in accordance with the B149.1 Installation Code.
  - Where required by the authority having jurisdiction, this installation must conform to the *Standard for Controls and Safety Devices for Automatically Fired Boilers* (ANSI/ASME CSD-1).
- Read Section VII to verify that the maximum combustion air and exhaust pipe lengths will not be exceeded in the planned installation. Also verify that the vent terminal can be located in accordance with Section VII.
- Make sure that the boiler is correctly sized:
  - For heating systems employing convection radiation (baseboard or radiators), use an industry accepted sizing method such as the *I=B=R* Guide RHH published by the Air-Conditioning, Heating and Refrigeration Institute (AHRI).

### III. Before Installing (continued)

- For new radiant heating systems, refer to the radiant tubing manufacturer's boiler sizing guidelines.
  - For system which includes an indirect water heater, make sure the boiler has the output called for by the indirect water heater manufacturer's instructions.
4. All boilers are shipped from the factory configured for use with natural gas. They may be converted for use with LP gas ("propane") using a proper conversion kit per Table 3.1. Use a combustion analyzer and follow all instructions supplied with conversion kit.

**Table 3.1: LP Conversion Kit**

Model Size	LP Conversion Kit PN
135, 150	107874-01
180	107875-01

#### **WARNING**

- **Do not attempt to operate this boiler on LP gas without converting it using the proper conversion kit.**
- **Do not attempt to convert this boiler to LP gas without the use of a combustion analyzer.**
- **Failure to follow the conversion instructions will result in operation of the boiler at unsafe Carbon Monoxide (CO) levels and may result in personal injury or loss of life. Improper conversion may also result in unreliable operation, resulting in property damage.**
- **Before attempting to operate this boiler at altitudes above 2000 ft., follow instructions shown in Appendix A of this manual.**

**NOTICE** This product must be installed by a licensed plumber or gas fitter when installed within the Commonwealth of Massachusetts. See Appendix C for additional important information about installing this product within the Commonwealth of Massachusetts.

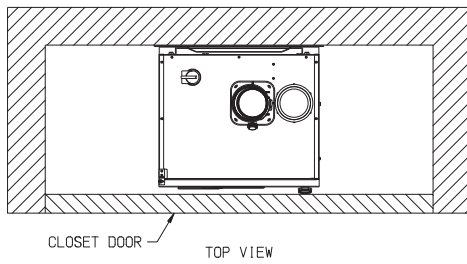
---

### IV. Locating the Boiler

---

1. Observe the minimum clearances shown in Figure 4.1. These clearances apply to combustible construction as well as non-combustible walls, floors, ceilings and doors.
2. Note the recommended service clearances in Figure 4.1. These service clearances are recommended, but may be reduced to the combustible clearances provided:
  - a. Access to the front of the boiler is provided through a door.
  - b. Access is provided to the condensate trap located beneath the boiler.Note that servicing the boiler will become increasingly difficult as these service clearances are reduced.
3. Observe the following clearances from piping to combustible construction:
  - Non-concentric vent (exhaust): ¼"
  - Air intake piping: 0"
  - Hot water piping: ¼"
4. The relief valve must be installed in the location shown in Figure 2.1 and must be in the same space as the boiler.
5. The boiler should be located so as to minimize the length of the vent system.
6. The combustion air piping must terminate where outdoor air is available for combustion and away from areas that will contaminate combustion air. Avoid areas near chemical products containing chlorine, chloride based salts, chloro/fluoro carbons, paint removers, cleaning solvents and detergents.

## IV. Locating the Boiler (continued)



THIS BOILER IS APPROVED FOR CLOSET INSTALLATION WITH THE FOLLOWING CLEARANCES FROM THE BOILER JACKET TO COMBUSTIBLE CONSTRUCTION:

TOP: 11-5/8", SIDES: 1/2", FRONT: 1/2", BOTTOM: 6"

THE ABOVE CLEARANCES ALSO APPLY TO NON-COMBUSTIBLE WALLS, DOORS, CEILINGS AND FLOORS.

CLEARANCES FROM PIPING TO COMBUSTIBLE CONSTRUCTION:

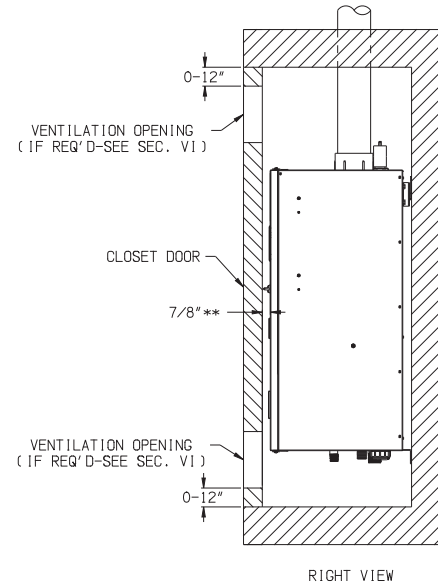
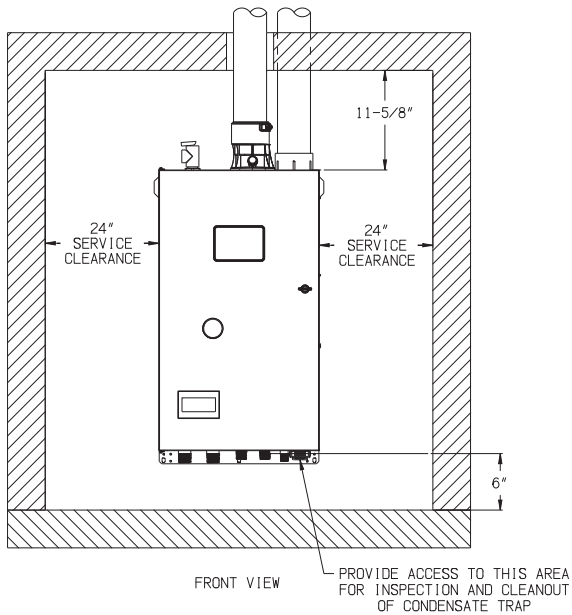
NON-CENTRIC VENT (EXHAUST): 1/4"

AIR INTAKE PIPING TO COMBUSTIBLE CONSTRUCTION: 0"

HOT WATER PIPING: 1/4"

RECOMMENDED SERVICE CLEARANCES:

SIDES: 24", FRONT: 24", BOTTOM: 24"



\*SIDE CLEARANCES MAY BE REDUCED TO 1/2"  
HOWEVER SERVICE WILL BECOME INCREASINGLY  
DIFFICULT WITH REDUCTION IN SIDE CLEARANCE.

\*\*CLEARANCE FOR DOOR KNOB

**Figure 4.1: Minimum Clearances To Combustible Construction**

---

## V. Mounting The Boiler

---

### A. Wall Mounting



**CAUTION** This boiler weights as much as 126 pounds:

- **Two people are required to safely lift this boiler onto the wall mounting hook.**
  - **Make sure that wall mounting hook is anchored to a structure capable of supporting the weight of the boiler and attached piping when filled with water. Jurisdictions in areas subject to earthquakes may have special requirements for supporting this boiler. These local requirements take precedence over the requirements shown below.**
1. If the boiler is installed on a framed wall, minimum acceptable framing is 2 x 4 studs on 16" centers. The boiler mounting holes are on 16" centers for installation between two studs at the standard spacing. In cases where the boiler cannot be centered between the studs, or where the studs are spaced closer than 16" apart, the boiler may be anchored to 3/4" plywood or horizontal 2 x 4's anchored to the studs.
  2. 5/16" x 2" lag screws and washers are provided for mounting this boiler. These lag screws are intended for mounting the boiler directly onto studs covered with 1/2" sheathing. When the boiler is attached to other types of construction, such as masonry, use fasteners capable of supporting the weight of the boiler and attached piping in accordance with good construction practice and applicable local codes.
  3. Make sure that the surface to which the boiler is mounted is plumb.
  4. Before mounting the boiler, make sure that wall selected does not have any framing or other construction that will interfere with the vent pipe penetration.
  5. Once a suitable location has been selected for the boiler, and any needed modifications have been made to the wall, use Figure 5.1 to locate holes "A" and "B". Make sure that the horizontal centerline of these holes is level. Holes "C" and "D" may also be drilled at this time or after the boiler is hung on the wall. If the 5/16" x 2" lag screws are used, drill 3/16" pilot holes.
  6. The wall mounting hook is used to secure the boiler to the shipping pallet. Remove this hook from the pallet and secure to the wall using the 5/16" x 2" lag screws and washers, or other suitable anchors as appropriate (Figure 5.2). Make sure the hook is level.
  7. Hang the boiler on the wall hook as shown in Figure 5.2.
  8. If not already done in Step (5) locate and drill holes "C" and "D" using the obround slots in the bottom mounting flange. Secure the bottom flange to the wall using the 5/16"x 2" lag screws, or other fasteners as appropriate (Figure 5.2).
  9. Verify that the front of the boiler is plumb. If it is not, install washers at holes "C" and "D" between the bottom mounting flange and the wall to adjust.



## V. Mounting The Boiler (continued)

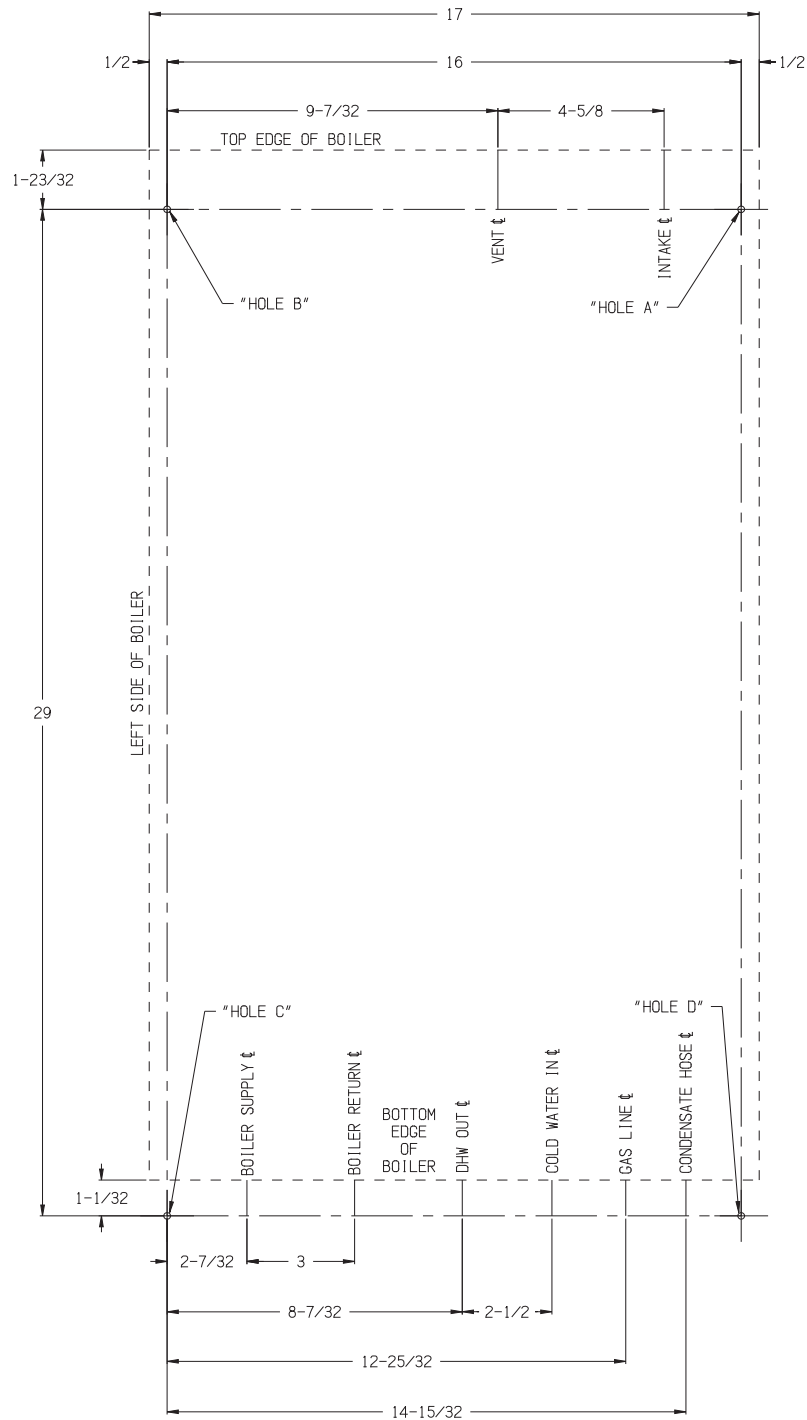
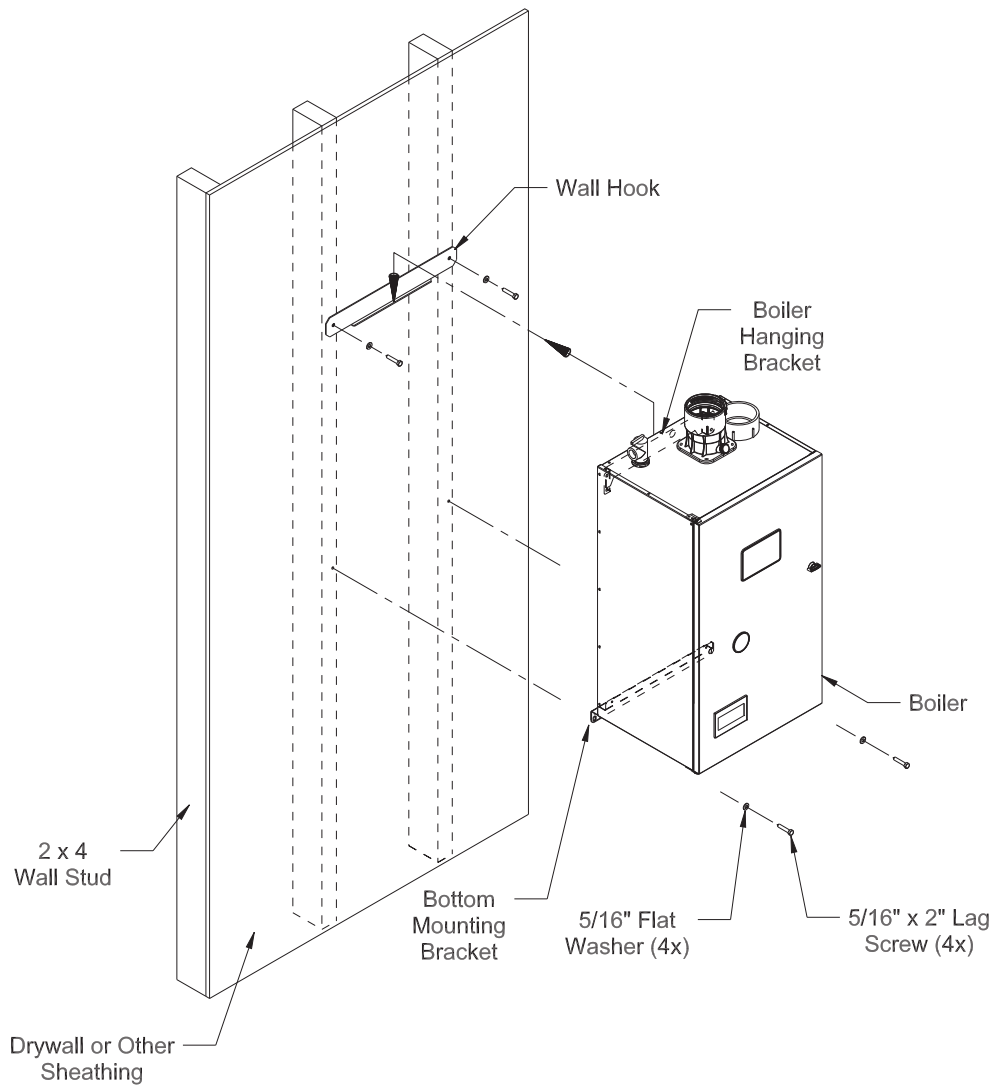


Figure 5.1 Wall Layout/Mounting Hole Location

## V. Mounting The Boiler (continued)



**Figure 5.2 Boiler Mounting Bracket Installation / Boiler Wall Mounting**

---

## VI . Air for Ventilation

---

**WARNING**

**Outdoor combustion air must be piped to the air intake. Never pipe combustion air from areas containing contaminants such as swimming pools and laundry room exhaust vents. Contaminated combustion air will damage the boiler and may cause property damage, personal injury or loss of life.**

Air for combustion must always be obtained directly from outdoors (see Section VII for intake piping). Although combustion air must always be obtained directly from outdoors, ventilation openings may still be required to prevent overheating of boiler components if the boiler is installed in a small space, such as a closet.

- If the recommended service clearances shown in Figure 4.1 can be maintained (with all doors to the room closed), no ventilation openings are required for this boiler.
- If the above service clearances cannot be maintained, provide two openings into the room, one near the floor and one near the ceiling. The top edge of the upper opening must be within 12" of the ceiling and the bottom edge of the lower opening within 12" of the floor. Each of these openings must have a free area of at least 100 square inches. The "free area" takes into account the blocking effect of mesh grilles and louvers. Where screens are used they must be no finer than ¼" (4 x 4) mesh.
- If this boiler is installed in a room with other appliances, provide adequate air for combustion and/or ventilation in accordance with the other appliance manufacturer's installation manual or applicable code. In cases where such provisions require two openings in excess of 100 square inches, no additional opening area is required for this boiler.

---

## VII. Venting

---



**WARNING** Asphyxiation Hazard. Failure to vent this boiler in accordance with these instructions could cause products of combustion to enter the building resulting in severe property damage, personal injury or death.

**Do not interchange vent systems or materials unless otherwise specified.**

**The use of thermal insulation covering vent pipe and fittings is prohibited.**

**Do not use a barometric damper, draft hood or vent damper with this boiler.**

**When using the CPVC/PVC vent option, the use of CPVC is required when venting in vertical or horizontal chase ways.**

**Any CPVC vent materials supplied with this boiler do not comply with B149.1.S1-07 and are not approved for use in Canadian jurisdictions that require vent systems be listed to ULC S636-2008. In these jurisdictions, vent this boiler using a listed ULC S636 Class IIB venting system.**

**Do not locate vent termination where exposed to prevailing winds. Moisture and ice may form on surface around vent termination. To prevent deterioration, surface must be in good repair (sealed, painted, etc.).**

**Do not locate air intake vent termination where chlorine, chlorofluorocarbons (CFC's), petroleum distillates, detergents, volatile vapors or other chemicals are present. Severe boiler corrosion and failure will result.**

**The use of cellular core PVC (ASTM F891), cellular core CPVC or Radel (polyphenolsulfone) is prohibited.**

**Do not locate vent termination under a deck.**

**Do not reduce specified diameters of vent and combustion air piping.**

**When installing vent pipe through chimney, as a chase, no other appliance can be vented into the chimney.**

**Do not allow low spots in the vent where condensate may pool.**

### A. Vent System Design

There are three basic ways to vent this boiler:

- **Horizontal (“Side Wall”) Twin Pipe Venting (Figure 7.0a)** - Vent system exits the building through an outside wall. Combustion air and flue gas are routed between the boiler and the terminal(s) using separate pipes for at least part of the way. A summary of Horizontal Twin Pipe venting options is shown in Table 7.5.
- **Vertical Twin Pipe Venting (Figure 7.0b)** - Vent system exits the building through a roof. Combustion air and flue gas are routed between the boiler and the terminal(s) using separate pipes for at least part of the way. A summary of Vertical Twin Pipe venting options is shown in Table 7.13
- **Split Venting (Figure 7.0c)** - Exhaust system exits the building through a roof, and combustion air is drawn from a terminal mounted on the side wall. A summary of split venting options is shown in Table 7.21

All of these systems are considered “direct vent” because the air for combustion is drawn directly from the outdoors into the boiler. One of the vent option columns in Tables 7.5, 7.13, 7.21 must match the planned vent and air intake system exactly.

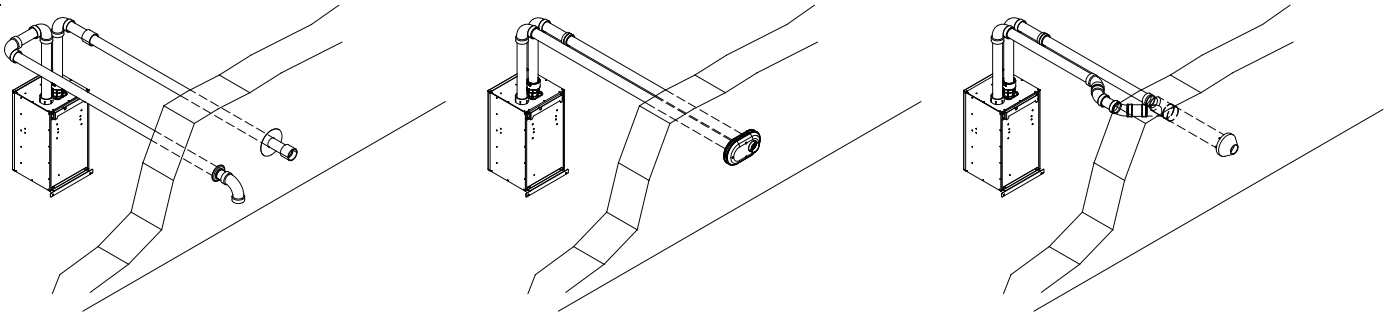
Design details applying to all vent systems are shown in this section. Observe all design requirements in this section, as well as those unique to the type of system being installed:

- B - Design Requirements Unique to Horizontal Twin Pipe Vent Systems
- C - Design Requirements Unique to Vertical Twin Pipe Vent Systems
- D - Design Requirements Unique to Split Vent Systems

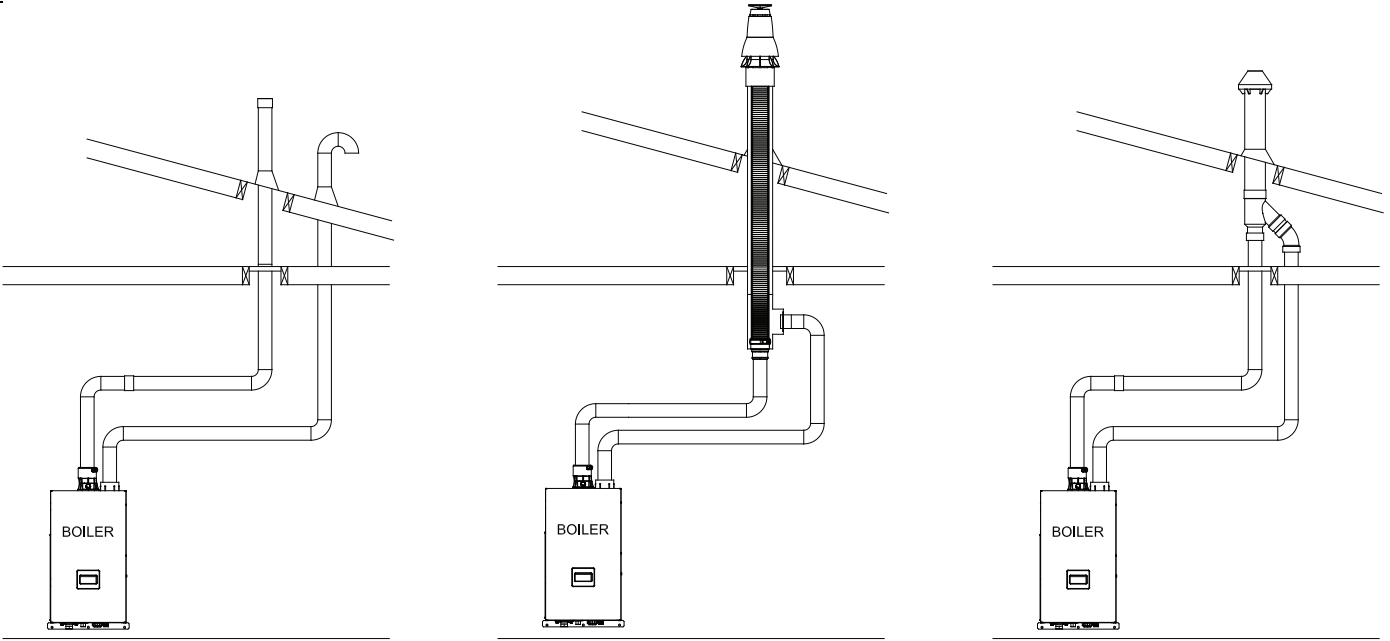
1. Approved Vent Systems and Materials – The following materials and vent systems may be used to vent this boiler:

- CPVC – Use only CPVC listed to ASTM F441. In Canada, this pipe must also be listed to ULC S636.
- PVC – PVC may be used only as permitted in this manual. All PVC must be listed to ASTM D2665. At least 30” of CPVC pipe, and at least one CPVC elbow, must be installed between the boiler’s vent connection and the PVC pipe. Use of foam core PVC is not permitted for venting. PVC vent pipe may not be used to vent this boiler in Canada.

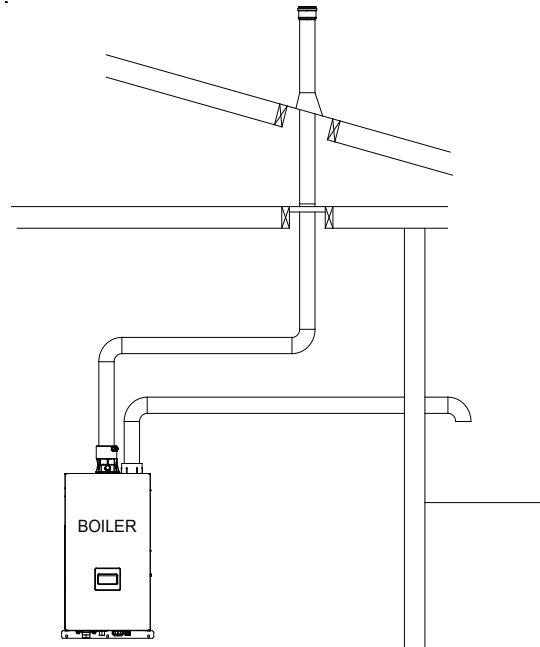
**VII. Venting A. Vent System Design (continued)**



**Figure 7.0a: Horizontal Twin Pipe**



**Figure 7.0b: Vertical Twin Pipe**



**Figure 7.0c: Split Venting**

## VII. Venting A. Vent System Design (continued)

- DuraVent PolyPro - ULC S636 listed Polypropylene special gas vent system.
- Selkirk Polyflue - ULC S636 listed Polypropylene special gas vent system.
- Centrotherm InnoFlue SW - ULC S636 listed Polypropylene special gas vent system.
- DuraVent FasNSeal Flex - UL 1738 listed Stainless Steel special gas vent system.

Use PVC and/or CPVC for the air intake system. PVC may be used for all air intake piping between the intake terminal and the boiler.

When CPVC and/or PVC pipe is used, it must be joined using primer and cement that is listed for use with the pipe material being joined (PVC, CPVC, or CPVC to PVC).

2. Vent Kit Available for Use with this Boiler - The following vent kit is available for CPVC/PVC vent systems installed with this boiler in the USA:

- 107039-02 - 3" CPVC/PVC Vent Kit

These kit include the following:

- (1) 30" CPVC Straight Pipe
- (1) 90 degree short bend CPVC Elbow
- (1) Straight PVC Coupling (for exhaust terminal)
- (1) 90 degree PVC Elbow (for intake termination)
- (2) Rodent screens

The CPVC Pipe and elbow supplied with these kits are not listed to ULC S636 and may not be used in Canada.

3. Maximum Vent and Air Intake Lengths - The maximum length of the vent air intake piping depends upon the vent option selected and the boiler size. See Tables 7.5, 7.13 or 7.21 for the maximum vent lengths. These maximum lengths apply to both the vent and intake piping (e.g. Option 1 may have up to 135ft of intake and 135ft of vent piping). For all vent systems, the lengths shown in Tables 7.5, 7.13 and 7.21 are in addition to the first 90° elbow. If more elbows are desired, the maximum allowable vent length must be reduced by the amount shown in Table 7.1 for each additional elbow used. Termination fittings are never counted.

It is recommended that all field supplied PVC or CPVC elbows be "1/4 Bend" (Sanitary 90° Elbow) or "Long Sweep 1/4 Bend" type elbows (Figure 7.2). In this manual "sanitary" and "long sweep" elbows are treated as having the same equivalent length.

*Example:*

*A 3" twin pipe horizontal CPVC/PVC vent system is planned for a horizontally vented 135 MBH model which has the following components in the vent system:*

- 1 ft CPVC Straight Pipe
- 90 CPVC Elbow (short bend)
- 1-1/2 ft CPVC Straight Pipe
- Coupling
- 10 ft PVC Straight Pipe
- 90 PVC Elbow (Sanitary Elbow Design)
- 15 ft PVC Straight Pipe
- PVC Coupling Terminal

*The Vent Option #1 column in Table 7.5 describes a horizontal direct vent system using 3" CPVC and PVC pipe. From this column, we see that the boiler may have a vent length of up to 135ft. The first CPVC 90 degree elbow is not considered. From Table 7.1, we see that the equivalent length of the 90 PVC elbow is 4ft and that the equivalent length of the coupling is 0ft. The total equivalent length of the planned venting system is therefore:*

*1ft (Straight CPVC) + 0ft (first short bend CPVC 90 Elbow) + 1.5ft (Straight CPVC) + 0ft (Coupling) + 10ft (Straight PVC) + 4ft (PVC 90 Sanitary Elbow) + 15ft (Straight PVC) + 0ft (Coupling Terminal) = 31.5ft.*

*Since Table 7.1 shows a maximum allowable vent length of 135ft, the planned vent system length is acceptable*

*The flex venting used on some of the Vertical Twin Pipe and Split Vent Options also reduces the maximum allowable vent length. See Sections VII-C or VII-D for details.*

## VII. Venting A. Vent System Design (continued)

**NOTICE** Do not exceed maximum vent/combustion air system length. Refer to Tables 7.1B, 7.5, 7.13, and 7.21 in this section for maximum vent/combustion air system length.

Use only vent and combustion air terminals and terminal locations shown in Tables 7.1B, 7.5, 7.13 and 7.21.

4. Vent Side Noise Attenuator - This boiler comes with a vent side noise attenuator. If equivalent vent length is less than 70 equivalent ft., install noise attenuator as described below. Attenuator is not required on size 135 at altitudes above 2000ft. Refer to Figure 7.1A.
  - a. To properly install attenuator, insert approximately a 9" length CPVC pipe in vent adaptor.
  - b. Fit a 3" CPVC coupling on length of pipe. Glue coupling to pipe using a field supplied cement and primer that is listed for use with materials being joined (CPVC and/or PVC).
  - c. Insert attenuator in length of pipe. Ensure attenuator tube is pointing down and sits inside 3" CPVC coupling.
  - d. Install remaining venting as described in this manual. If using one of the polypropylene or stain less steel vent systems listed described in this manual, use a listed adapter to adapt from CPVC to be the other vent system.

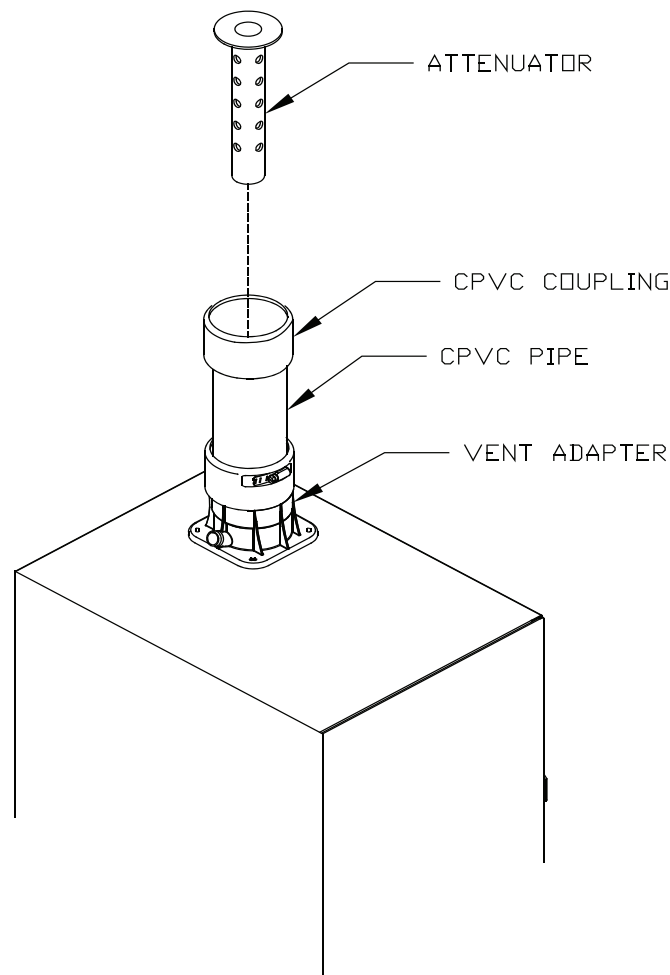


Figure 7.1A: Installation of Vent Side Attenuator

**NOTICE** This boiler comes with a vent side noise attenuator. If equivalent vent length is less than 70 equivalent ft., install vent side noise attenuator as described in this manual. Failure to do so may result in boiler combustion noise during operation. Attenuator is not required on size 135 at altitudes above 2000ft.



## VII. Venting A. Vent System Design (continued)

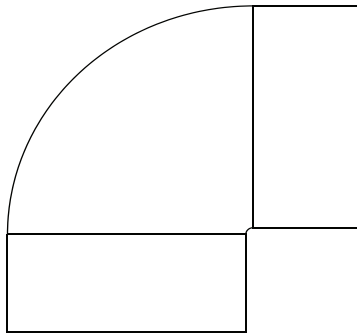
**NOTICE Do not exceed maximum vent/combustion air system length. Refer to Tables 7.1B, 7.5, 7.13, and 7.21 in this section for maximum vent/combustion air system length.**

**Use only vent and combustion air terminals and terminal locations shown in Tables 7.5, 7.13 and 7.21.**

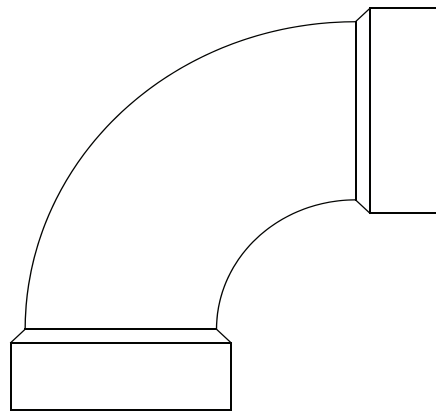
5. Minimum Vent and Air Intake Lengths - Observe the minimum vent lengths shown in Tables 7.5, 7.13 and 7.21.
6. Clearances to Combustibles - Maintain the following clearances from the vent system to combustible construction:
  - Vent - 1/4" (also observe clearances through both combustible and non-combustible walls - see 9)
  - Air Intake - 0"
  - Concentric Portion of Concentric Terminals - 0"
7. Pitch of Horizontal Vent Piping - Pitch all horizontal vent piping so that any condensate which forms in the piping will run towards the boiler.
  - Pitch CPVC/PVC vent piping 1/4" per foot.
  - Pitch Polypropylene vent piping 5/8" per foot.

**Table 7.1B: Vent/ Air Intake Fitting Equivalent Length**

CPVC/PVC Fitting	Equivalent Length (ft)	PolyPro, Polyflue or InnoFlue Vent Fitting	Equivalent Length (ft)	FasNSeal Vent Fitting	Equivalent Length (ft)
3" 90° Elbow ("Sanitary Bend")	4.0	3" 90° Elbow	8.7	3" 90° Elbow	4.0
3" 45° Elbow	2.0	3" 45° Elbow	4.6	3" 45° Elbow	2.0
3" 90° Elbow ("Short Bend")	10.0			3" Straight Tee	18.0
3" Coupling	0.0			3" Boot Tee	8.0



"SHORT BEND" ELBOW



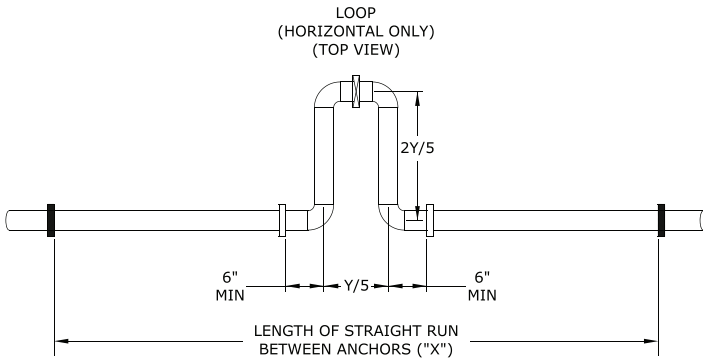
1/4 BEND (a.k.a "SANITARY BEND") ELBOW ("LONG SWEEP ELBOW LOOKS SIMILAR AND HAS SAME EQUIVALENT LENGTH)

Figure 7.2: CPVC and PVC Elbows

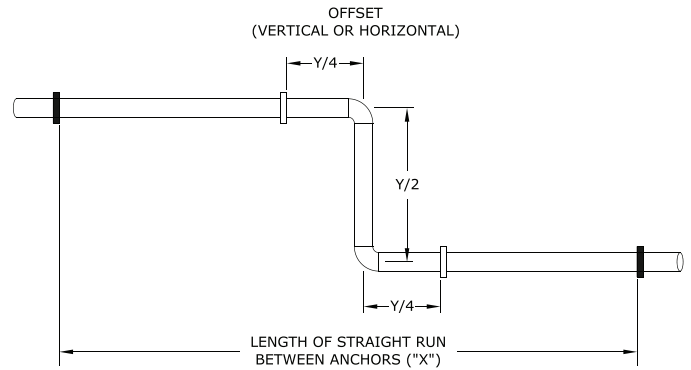
## VII. Venting A. Vent System Design (continued)

8. Supporting Pipe - Vertical and horizontal sections of pipe must be properly supported. Maximum support spacing is as follows:
- Support CPVC/PVC horizontally and vertically every 4 feet.
  - Support DuraVent PolyPro horizontally near the female end of each straight section of pipe and vertically every 10 feet.
  - Support Centrotherm InnoFlue horizontally every 39 inches with additional supports at elbows and vertically every 78".
  - Support 3" Polyflue horizontally every 39". Support vertical runs of 3" Polyflue every 16 ft.
  - Support DuraVent FasNSeal horizontally every 6ft or less. Support vertical runs at the base and every 12ft or less.
- Les instructions d'installation du système d'évacuation doivent préciser que les sections horizontales doivent être supportées pour prévenir le fléchissement. Les méthodes et les intervalles de support doivent être spécifiés. Les instructions doivent aussi indiquer les renseignements suivants:
- les chaudières de catégories II et IV doivent être installées de façon à empêcher l'accumulation de condensat: et
  - si nécessaire, les chaudières de catégories II et IV doivent être pourvues de dispositifs d'évacuation du condensat.
9. Allowing for Thermal Expansion -
- For CPVC/PVC pipe design, the vent system shall allow 3/8" of thermal expansion for every 10ft of CPVC/ PVC pipe. The boiler will always act as an anchor to one end of the vent system. If at all possible, select and install hangers and wall thimbles so that the vent system can expand towards the terminal. When a straight run of pipe exceeds 20ft and must be restrained at both ends, an offset or expansion loop must be provided (Figures 7.3a, 7.3b). When a straight horizontal run of pipe exceeds 20ft and is restrained at one end with an elbow at the other, avoid putting a hanger or guide less than "Y" inches from the elbow in the adjoining straight section (Figure 7.3c). Thermal expansion fittings are not permitted.
  - When properly assembled, expansion of PolyPro, Polyflue and InnoFlue vent systems is accommodated at the joints. See Section VII - F, G & H of this manual for details.
  - Stainless steel vent systems must be free to expand and contract in accordance with manufacturer's installation instructions.
10. Running PVC Vent Pipe Inside Enclosures and Through Walls - PVC vent pipe must be installed in a manner that permits adequate air circulation around the outside of the pipe:
- Do not enclose PVC venting - Use CPVC in enclosed spaces, even if PVC is installed upstream.
  - PVC venting may not be used to penetrate combustible or non-combustible walls unless all of the following conditions are met:
    - a. The wall penetration is at least 66 inches from the boiler as measured along the vent.
    - b. The wall is 12" thick or less
    - c. An airspace of at least that shown in Figure 7.4 is maintained around the OD of the vent.If any of these conditions cannot be met, use CPVC for the wall penetration.
11. Vent Manufacturer's Instructions – The vent system manufacturer may have additional vent system design requirements. Read and follow the vent manufacturer's instructions in addition to those shown here. Where a conflict arises between the two sets of instructions, the more restrictive requirements shall govern.

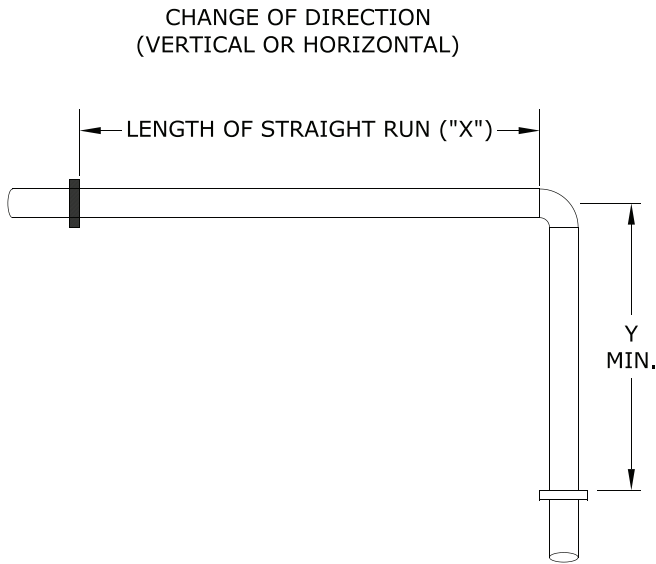
## VII. Venting A. Vent System Design (continued)



**Figure 7.3a**

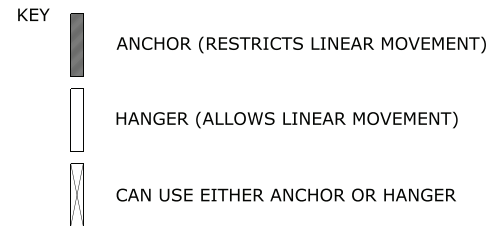


**Figure 7.3b**



**Figure 7.3c**

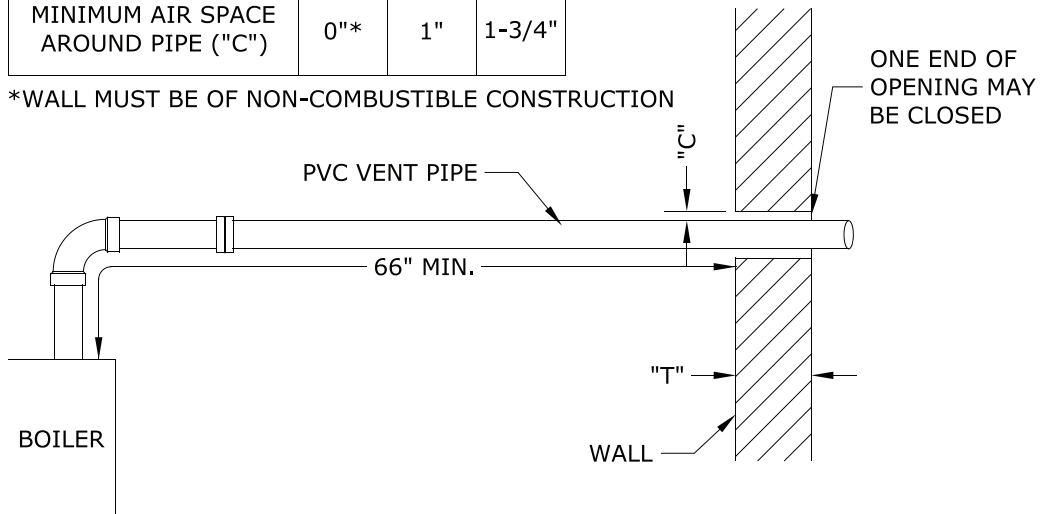
PIPE DIA. (IN.)	"X" (FT.)	"Y" (IN.)
3	20	50
	30	61
	40	70
	50	79
	60	86



**Figure 7.3: Expansion Loops for CPVC/PVC Pipe**

MAX. WALL THICKNESS ("T")	2"*	6"	12"
MINIMUM AIR SPACE AROUND PIPE ("C")	0"*	1"	1-3/4"

\*WALL MUST BE OF NON-COMBUSTIBLE CONSTRUCTION



**Figure 7.4: Wall Penetration Clearances for PVC Vent Pipe**

## VII. Venting B. Design Requirements Unique to Horizontal Twin Pipe Venting Systems (continued)

### B. Design Requirements Unique to Horizontal Twin Pipe Venting Systems

Table 7.5 summarizes all horizontal twin pipe vent options. Illustrations of horizontal twin pipe vent systems are shown in Figures 7.6 – 7.10. In addition to the requirements in Section VII - A, observe the following design requirements:

#### 1. Permitted Terminals for Horizontal Venting:

Terminal Option A: Fittings (Acceptable for Vent Options 1-4) – Vent terminates in a plain end (coupling for PVC, bell end for PolyPro, Polyflue and plain end pipe for InnoFlue). Intake terminates in a PVC 90 sweep elbow pointing down. Outer edge of both terminals must be within 10” of the wall surface (Figures 7.6, 7.9). The section of DuraVent PolyPro, Centrotherm InnoFlue or Selkirk Polyflue exposed to the outdoors must be UV resistant.

Use of rodent screens (not supplied) is generally recommended for both terminations. These can be fabricated from 2 x 2 (1/2” mesh) stainless steel screen. Rodent screens are installed as shown in Figure 7.28. Rodent screens (“bird guards”) for PolyPro, InnoFlue and Polyflue are as follows:

Size/Vent System	Rodent Screen (“Bird Guard”)
3” PolyPro	DuraVent # 3PPS-BG
3” Polyflue	Selkirk # 3PV-HVST
3” InnoFlue	Centrotherm # IASPP03

If necessary to achieve required clearance above grade, CPVC or CPVC/PVC vent systems may be terminated using fittings on snorkels as shown in Figure 7.12. When this is done, the equivalent length of all pipe on the exterior of the building, except for the terminal fittings themselves, must be counted when calculating the equivalent length. The maximum vertical run of the snorkel is 7 feet. Brace both the vent and inlet piping if required. PolyPro, InnoFlue and Polyflue may not be snorkeled.

Terminal Option B: Ipex Low Profile Terminal (Acceptable for Vent Option 1) – This terminal is shown in Figure 7.7. If the terminal is oriented vertically (alternate orientation shown in Fig 7.7) the exhaust opening must be on the top as shown. See Section VII - E of this manual and the Ipex instructions provided with the terminal, for installation details.

Terminal Option C: DiversiTech “Low Profile” Terminal (Acceptable for Vent Option 1) – This terminal is shown in Figure 7.7. If the terminal is oriented vertically (alternate orientation shown in Fig 7.7) the exhaust opening must be on the top as shown. See Section VII - E of this manual and the DiversiTech instructions provided with the terminal, for installation details.

Terminal Option D: Ipex FGV Concentric Terminal (Acceptable for Vent Option 1) - This terminal is shown in Figure 7.8 and may be used with CPVC/PVC vent systems. This terminal is available in various lengths and in both PVC and CPVC. Terminals acceptable for use with these vent options are as follows:

Ipex PN	FGV Concentric Terminal Description
196006	3 x 20” PVC
196106	3 x 32” PVC
196116	3 x 44” PVC
197107	3 x 32” CPVC
197117	3 x 44” CPVC

See Section VII - E of this manual and the Ipex instructions provided with the terminal, for installation details.

Terminal Option E: DiversiTech Concentric Terminal (Acceptable for Vent Option 1) - This terminal is shown in Figure 7.8 and may be used with CPVC/PVC vent systems. See Section VII - E of this manual and the DiversiTech instructions provided with the terminal, for installation details.

Terminal Option F: DuraVent PolyPro Concentric Terminal (Acceptable for Vent Option 2) - This terminal is shown in Figure 7.10 and may be used with DuraVent 3” PolyPro vent systems. See Section VII - F of this manual and the DuraVent instructions provided with the terminal, for installation details.

**VII. Venting B. Design Requirements Unique to Horizontal Twin Pipe Venting Systems (continued)**

**Table 7.5: Summary of Horizontal Twin Pipe Venting Options**

<b>Vent Option</b>		<b>1</b>	<b>2</b>	<b>3</b>	<b>4</b>
Illustrated in Figure		7.6, 7.7, 7.8	7.9, 7.10	7.9	7.9
Pipe Penetration through Structure	Vent	Wall	Wall	Wall	Wall
	Intake	Wall	Wall	Wall	Wall
Material	Vent	CPVC/ PVC (Note 2)	DuraVent PolyPro (Rigid)	Selkirk Polyflue	Centro-therm InnoFlue SW
	Intake	PVC	PVC	PVC	PVC
Nominal Diameter	Vent	3"	3"	3"	3"
	Intake	3"	3"	3"	3"
Min Equivalent Vent Length:					
Models	135	12"	12"	12"	12"
	150	52"	52"	52"	52"
	180	52"	52"	52"	52"
Max Equivalent Vent Length (Note 1):					
Models	135	135ft	135ft	135ft	135ft
	150	135ft	135ft	135ft	135ft
	180	135ft	135ft	135ft	135ft
<b>Terminal Option A</b> (Fittings)	Vent	Coupling w/screen (Note 3)	3PPS-12B or 3PPS-36B w/screen	3PF-10UV or 3PF-39UV w/screen	ISEP03 or ISEP0339 w/screen
	Intake	Elbow w/screen (Note 3)	Elbow w/screen	Elbow w/screen	Elbow w/screen
<b>Terminal Option B</b> (Ipex Low Profile)		Ipex #196985	Not Permitted		
<b>Terminal Option C</b> (DiversiTech HVENT)		HVENT-3	Not Permitted		
<b>Terminal Option D</b> (Ipex FGV Concentric)		Ipex 196006	Not Permitted		
<b>Terminal Option E</b> (DiversiTech CVENT)		CVENT-3	Not Permitted		
<b>Terminal Option F</b> (DuraVent Horizontal Concentric)		Not Permitted	3PPS-HK	Not Permitted	

Notes:

1. Max vent lengths shown also apply to the intake. For example, Vent Option #1 may have up to 135ft of vent pipe and also up to 135 ft of intake pipe.
2. First 30" of vent and vent Elbow connected to boiler must be CPVC. Downstream vent pipe can be PVC except as noted in text.
3. PVC Terminal coupling and inlet elbow may be offset on snorkels as shown in Figure 7.12.

## VII. Venting B. Design Requirements Unique to Horizontal Twin Pipe Venting Systems (continued)

2. Horizontal Vent and Air Intake Terminal Location - Observe the following limitations on the vent terminal location (also see Figure 7.11). When locating a concentric terminal, observe the limitations outlined below for "vent terminals".
- Vent terminal must be at least 1 foot from any door, window, or gravity inlet into the building.
  - When Terminal Option A (fittings) are used, maintain the correct clearance and orientation between the intake and exhaust terminals. If possible, locate vent and combustion air terminals on the same wall to prevent nuisance shutdowns. If not, boiler may be installed with roof vent terminal and sidewall combustion air terminal (see Section D). When installed on the same wall, locate exhaust vent terminal at same height or higher than combustion air intake terminal. Horizontal separation: Recommended: 36", Minimum: 12", Maximum: none. Minimum horizontal separation of 12" is required regardless of vertical separation.
  - The bottom of all terminals must be at least 12" above the normal snow line. In no case should they be less than 12" above grade level.
  - The bottom of the vent terminal must be at least 7 feet above a public walkway.
  - Do not install the vent terminal directly over windows or doors.
  - The bottom of the vent terminal must be at least 3 feet above any forced air inlet located within 10 feet.
  - USA Only: A clearance of at least 4 feet horizontally must be maintained between the vent terminal and gas meters, electric meters, regulators, and relief equipment. Do not install vent terminal over this equipment. In Canada, refer to B149.1 Installation Code for clearance to meters, regulators and relief equipment.
  - Do not locate the vent terminal under decks or similar structures.
  - Top of terminal must be at least 24" below ventilated eaves, soffits and other overhangs. In no case may the overhang depth exceed 48". Where permitted by the authority having jurisdiction and local experience, the terminal may be located closer to unventilated soffits. For the minimum vertical separation, which depends upon the depth of the soffit, see Figure 7.11.
  - Vent terminal must be at least 6 feet from an inside corner.
  - Under certain conditions, water in the flue gas may condense, and possibly freeze, on objects around the vent terminal including on the structure itself. If these objects are subject to damage by flue gas condensate, they should be moved or protected.
  - Install the vent and air intake terminals on a wall away from the prevailing wind. Reliable operation of this boiler cannot be guaranteed if these terminals are subjected to winds in excess of 40 mph.
  - Air intake terminal must not terminate in areas that might contain combustion air contaminants, such as near swimming pools. See WARNING on page 14.

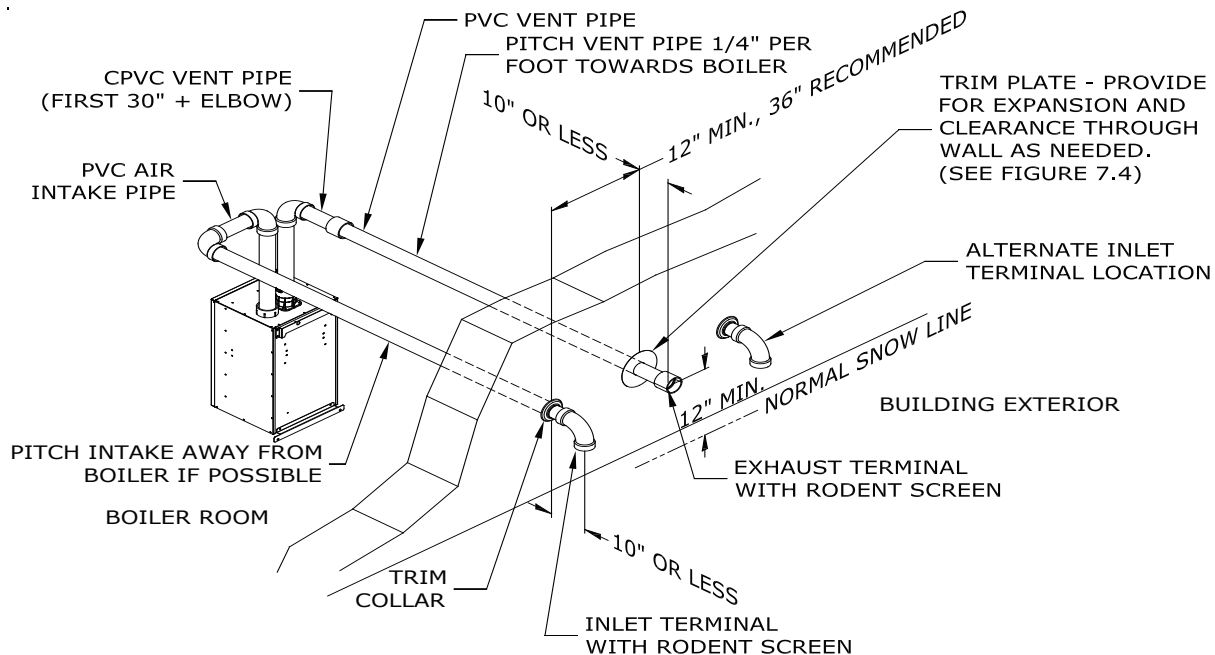
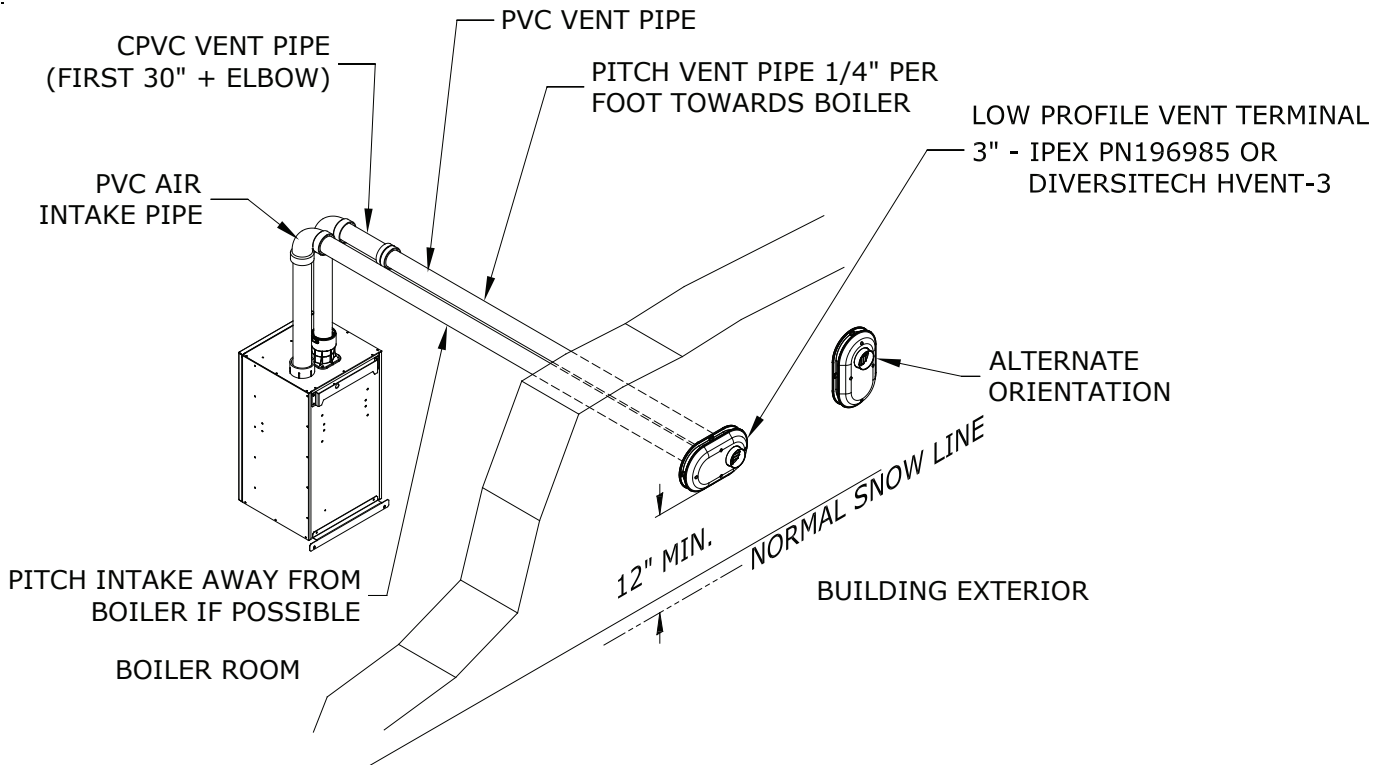
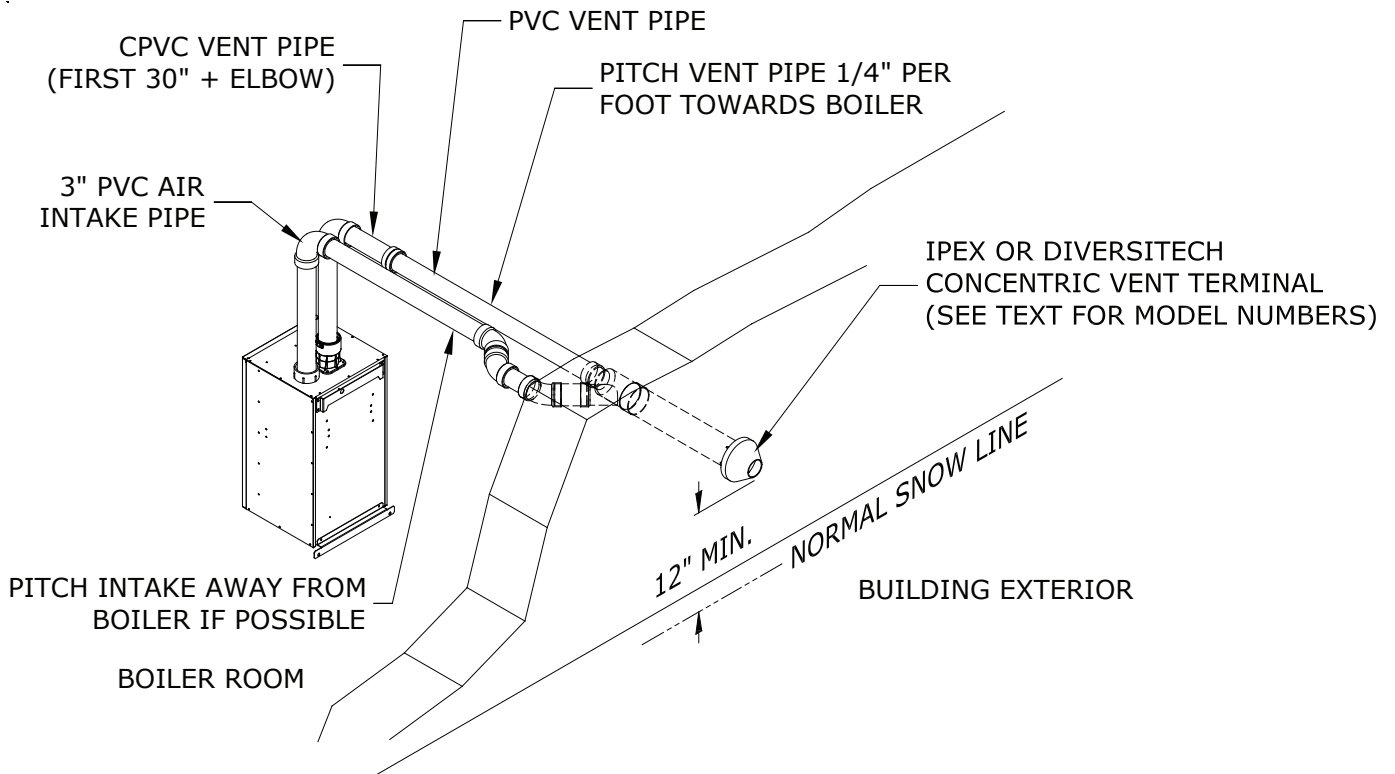


Figure 7.6: Horizontal CPVC/PVC Venting, (Vent Option #1, Terminal Option A)

**VII. Venting B. Design Requirements Unique to Horizontal Twin Pipe Venting Systems (continued)**



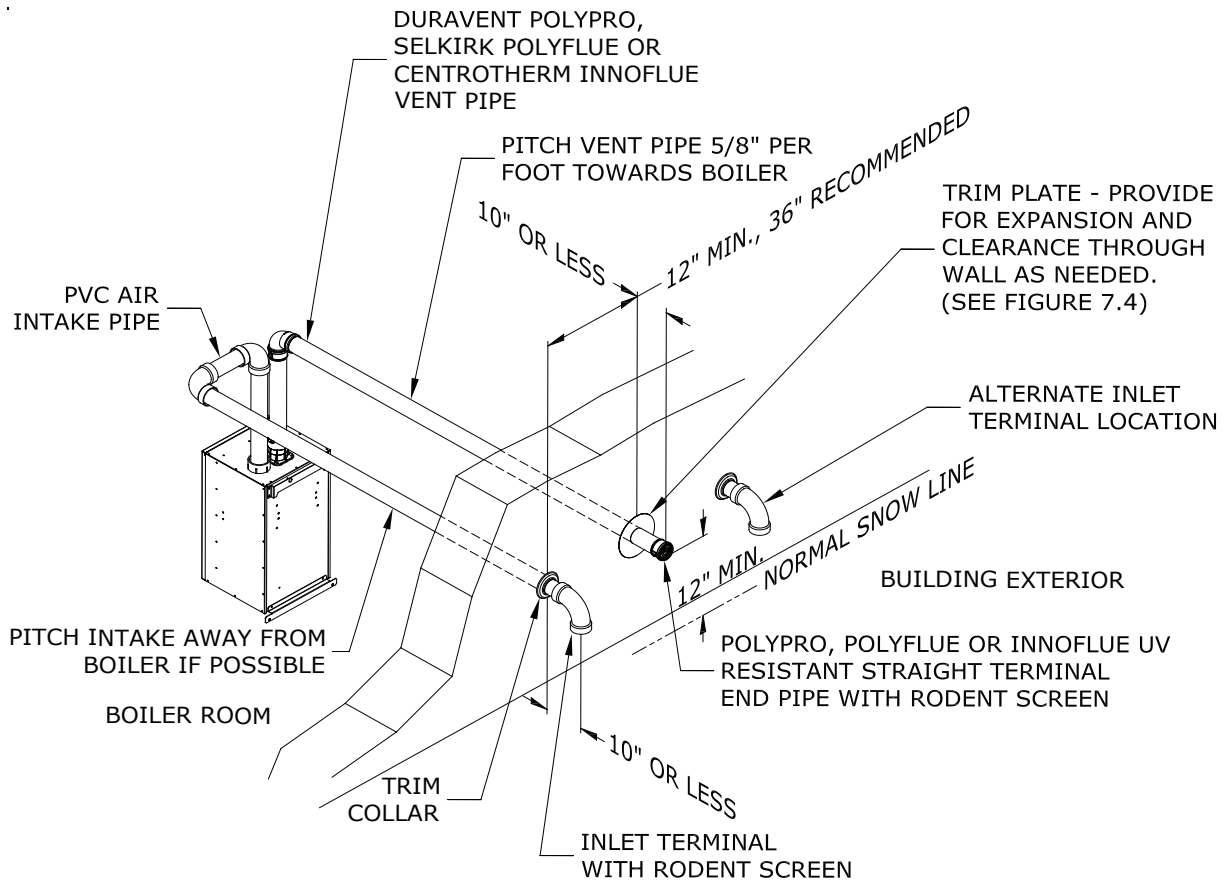
**Figure 7.7: Horizontal CPVC/PVC Venting with Low Profile Terminal, (Vent Option #1, Terminal Options B & C)**



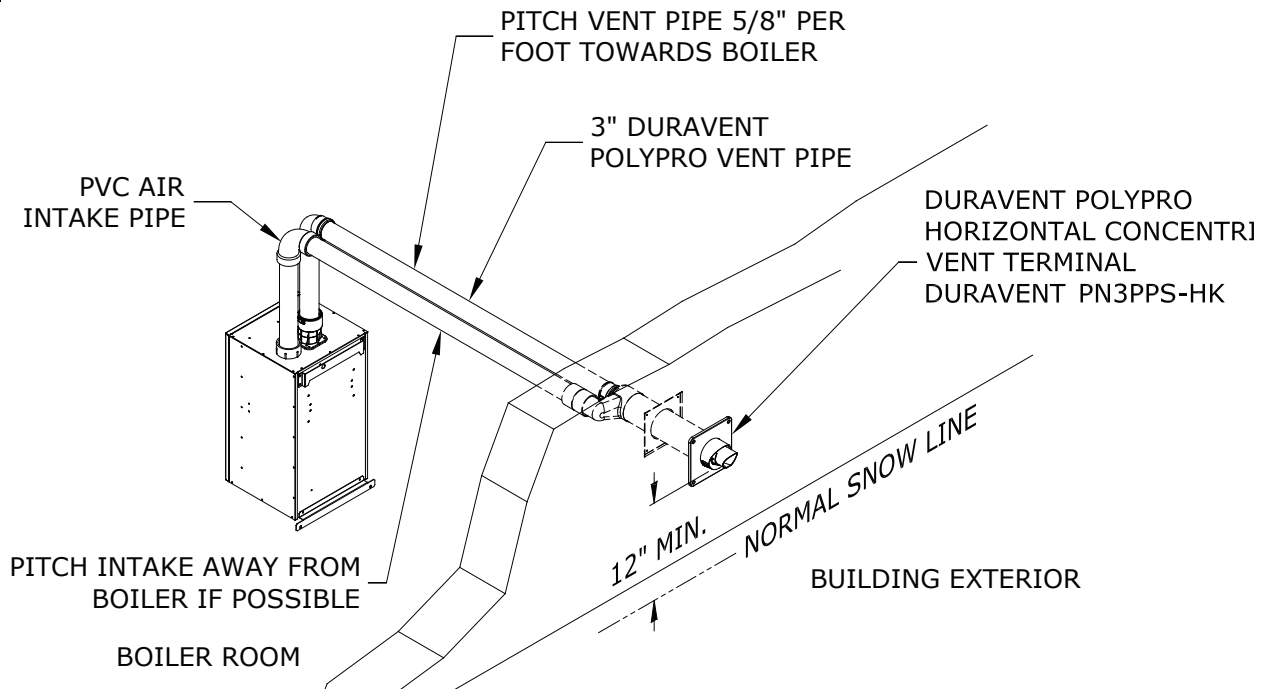
**Figure 7.8: Horizontal CPVC/PVC Venting with Concentric Vent Terminal, (Vent Option #1, Terminal Options D & E)**



**VII. Venting B. Design Requirements Unique to Horizontal Twin Pipe Venting Systems (continued)**

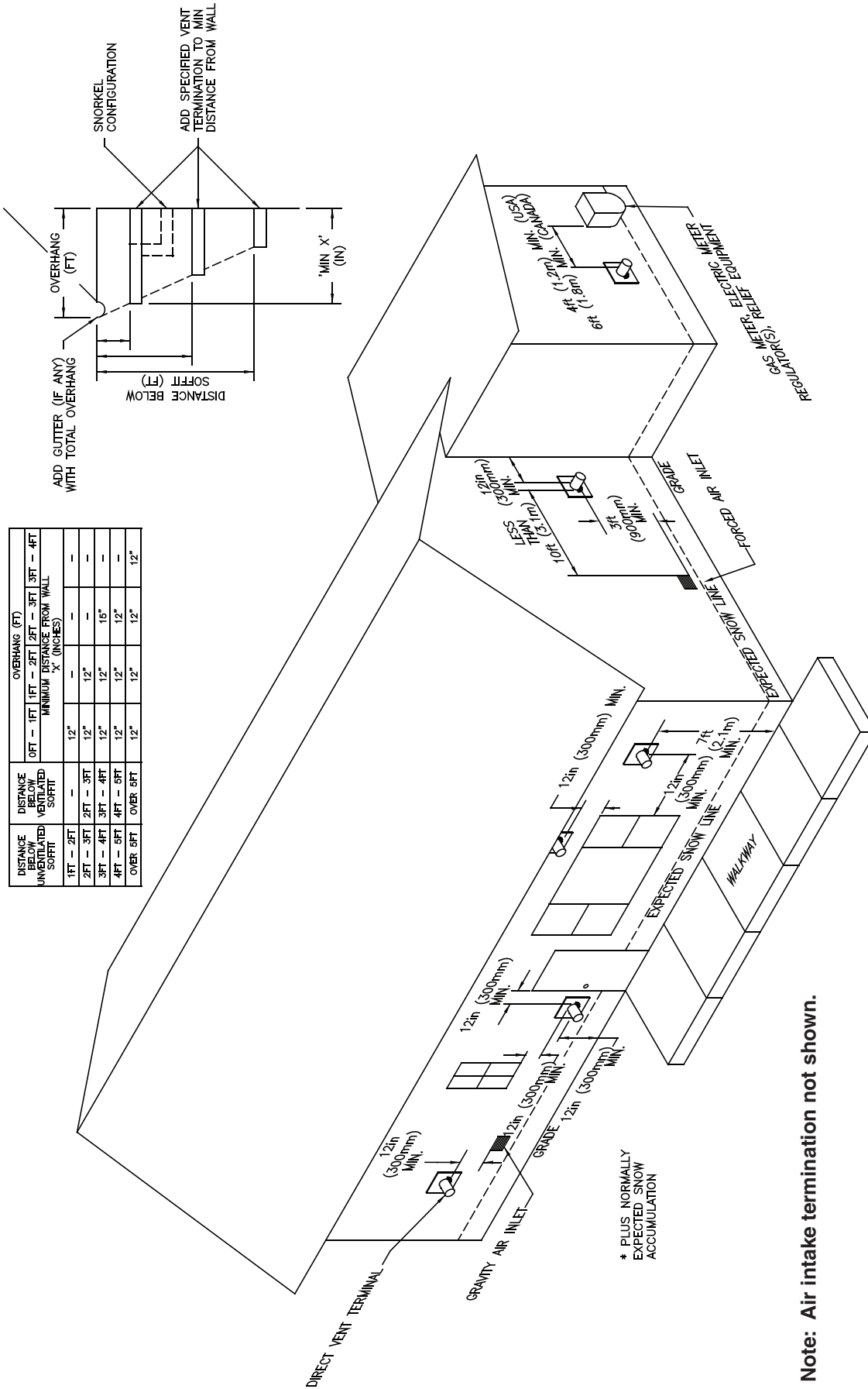


**Figure 7.9: Duravent PolyPro, Selkirk, Polyflue or Centrotherm InnoFlue Horizontal Venting (Vent Options #2-4, Terminal Option A)**



**Figure 7.10: Duravent PolyPro Horizontal Venting with Concentric Terminal, (Vent Option #2, Terminal Option F)**

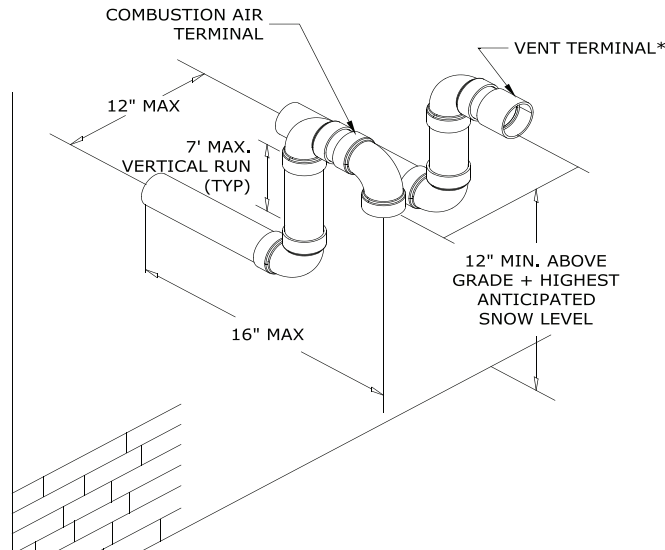
VII. Venting B. Design Requirements Unique to Horizontal Twin Pipe Venting Systems (continued)



Note: Air intake termination not shown.

Figure 7.11: Location of Vent Terminal Relative to Windows, Doors, Grades, Overhangs, Meters and Forced Air Inlets - Two-Pipe System Vent Terminal (Shown) Two-Pipe System Air Intake Terminal (Not Shown)

## VII. Venting C. Design Requirements Unique to Vertical Venting Systems (continued)



**Figure 7.12: Snorkel Terminal Configuration (CPVC/PVC Vent Systems Only)**

### C. Design Requirements Unique to Vertical Venting Systems

Table 7.13a summarizes all vertical twin pipe vent options. Table 7.13.b summarizes vent options in which an abandoned B-vent chimney is used both as a chase for the vent pipe and as a conduit for combustion air. In addition to the requirements in Section VII - A, observe the following design requirements:

#### 1. Permitted Terminals for Vertical Venting

Terminal Option H: Fittings (Acceptable for Vent Options 5-8) – Vent terminates in a plain end (coupling for PVC, bell end for PolyPro, Polyflue and plain end pipe for InnoFlue). Intake terminates in a PVC 180 elbow pointing down (two sweep 90's may be substituted). Observe the clearances from the roof, and normal snow line on the roof, shown in Figures 7.15 and 7.17. The section of PolyPro, Polyflue or InnoFlue exposed to the outdoors must be UV resistant.

Use of rodent screens (not supplied) is generally recommended for both terminations. These can be fabricated from 2 x 2 (1/2" mesh) stainless steel screen. Rodent screens are installed as shown in Figure 7.29. Rodent screens ("bird guards") for PolyPro, InnoFlue and Polyflue are as follows:

Size/Vent System	Rodent Screen ("Bird Guard")
3" PolyPro	DuraVent # 3PPS-BG
3" Polyflue	Selkirk # 3PV-HVST
3" InnoFlue	Centrotherm # IASPP03

Terminal Option I: Ipex FGV Concentric Terminal (Acceptable for Vent Option 5) - This terminal is shown in Figure 7.16 and may be used with CPVC/PVC vent systems. Use a compatible roof flashing and storm collar in accordance with the Ipex instructions for this terminal. This terminal is available in various lengths and in both PVC and CPVC. Terminals acceptable for use with these vent options are as follows:

Ipex PN	FGV Concentric Terminal Description
196006	3 x 20" PVC
196106	3 x 32" PVC
196116	3 x 44" PVC
197107	3 x 32" CPVC
197117	3 x 44" CPVC

See Section VII - E of this manual and the Ipex instructions provided with the terminal, for installation details.

## VII. Venting C. Design Requirements Unique to Vertical Venting Systems (continued)

**Table 7.13a: Summary of Vertical Twin Pipe Venting Options**

Option		5	6	7	8
Illustrated in Figure		7.15, 7.17	7.17, 7.18	7.17	7.17
Pipe Penetration through Structure	Vent	Roof	Roof	Roof	Roof
	Intake	Roof	Roof	Roof	Roof
Material	Vent	CPVC/ PVC (Note 2)	DuraVent PolyPro (Rigid)	Selkirk Polyflue	Centro- therm InnoFlue SW
	Intake	PVC	PVC	PVC	PVC
Nominal Diameter	Vent	3"	3"	3"	3"
	Intake	3"	3"	3"	3"
Min Equivalent Vent Length:					
Models	135	12"	12"	12"	12"
	150	52"	52"	52"	52"
	180	52"	52"	52"	52"
Max Equivalent Vent Length (Note 1):					
Models	135	135ft	135ft	135ft	135ft
	150	135ft	135ft	135ft	135ft
	180	135ft	135ft	135ft	135ft
<b>Terminal Option H</b> (Fittings)	Vent	Coupling w/Screen	3PPS-12B or 3PPS-36B w/Screen	3PF-10UV or 3PF-39UV w/Screen	ISEP03 or ISEP0339 w/Screen
	Intake	180 Elbow w/Screen	180 Elbow w/Screen	180 Elbow w/Screen	180 Elbow w/Screen
<b>Terminal Option I</b> (Ipex FGV Concentric)		Ipex 196006 (Note 3)	Not Permitted		
<b>Terminal Option J</b> (DiversiTech CVENT Concentric)		CVENT-3	Not Permitted		
<b>Terminal Option K</b> (DuraVent Vertical Concentric)		Not Permitted	3PPS-VK	Not Permitted	

Notes:

1. Max vent lengths shown also apply to the intake. For example, Vent Option #1 may have up to 135ft of vent pipe and also up to 135 ft of intake pipe.
2. First 30" of vent and vent Elbow connected to boiler must be CPVC. Downstream vent pipe can be PVC except as noted in text.
3. Ipex FGV Concentric Terminal available in various lengths and also CPVC (see text).

**All vertical terminals require compatible roof flashing and storm collars.**

## VII. Venting C. Design Requirements Unique to Vertical Venting Systems (continued)

**Table 7.13b: Summary of Vertical “B-Vent Air Chase” Vent Options (B-Vent Chase MUST Be Sealed)**

Option		9	10
Illustrated in Figure		7.19	7.20
Pipe Penetration Through Structure	Vent	Roof	Roof
	Intake	Roof	Roof
Material	Vent	DuraVent PolyPro (Rigid/Flex)	Centrotherm InnoFlue SW/Flex
	Intake	B Vent/PVC	B Vent/PVC
Nominal Diameter	Vent	3"	3"
	Intake	3"	3"
Min B Vent ID		6"	6"
Min Equivalent Vent Length:			
Models	135	36"	36"
	150	52"	52"
	180	52"	52"
Max Equivalent Vent Length (Note 1):			
Models	135	135ft	135ft
	150	135ft	135ft
	180	135ft	135ft
Vent Manufacturer's PN for Flex Termination/Components Required		3PPS-VFT 3PPS-BV* 3PPS-FLEX**	IFBK03**** IAWP03B

\* Specify size of B vent (e.g. 3PPS-BV6 is for use with 6" B vent)

\*\* Specify length in feet.

\*\*\*\* Specify Flex length and B-vent diameter (e.g. IFBK032506 includes 25ft of flex and used with 6" B vent)

Note 1: Max vent lengths shown also apply to the intake. Flex vent reduces the maximum allowable vent length. See equivalent lengths for flex vent shown in Table 7.14 and sizing example on next page.

**NOTICE** Vertical venting and combustion air roof penetrations (where applicable) require the use of roof flashing and storm collar, which are not supplied with the boiler, to prevent moisture from entering the structure.

## VII. Venting C. Design Requirements Unique to Vertical Venting Systems (continued)

Terminal Option J: DiversiTech Concentric Terminal (Acceptable for Vent Option 5) - This terminal is shown in Figure 7.16 and may be used with CPVC/PVC vent systems. See Section VII - E of this manual and the DiversiTech instructions provided with the terminal, for installation details.

Terminal Option K: DuraVent PolyPro Concentric Terminal (Acceptable for Vent Option 6) - This terminal is shown in Figure 7.18 and may be used with DuraVent 3" PolyPro vent systems. Use a compatible DuraVent roof flashing and storm collar in accordance with the DuraVent instructions for this terminal. See Section VII - F of this manual and the DuraVent instructions provided with the terminal, for installation details.

2. Vertical Vent and Air Intake Location – Observe the following clearances from roof mounted terminals:
  - Bottom of air intake opening must be at least 12" above the normal snow line anticipated on the roof.
  - Exhaust opening must be at least 2ft above any portion of the roof or structure located within horizontally within 10ft.
  - For terminal option H, maintain at least 12" of vertical separation between the exhaust and intake opening as shown in Figure 7.15 and 7.17.
  
3. Requirements for B-Vent Air Chase Options – Observe the following additional requirements when using an abandoned B-vent chimney as an air chase as described in Options # 9 & 10. Also refer to Figures 7.19 & 7.20.
  - B vent must be clean and in good condition.
  - Use of flex Polypropylene outside of B-vent chimney is not permitted.
  - All joints and seams in the B-vent must be sealed with RTV. If these seams are not accessible, vent options 9 - 10 cannot be used while complying with the National Fuel Gas Code (as an alternative, the B-vent chimney can be used as a chase for the vent pipe while combustion air is piped from an outside wall - see Section VII - D for additional details).
  - All venting is Polypropylene supplied by the vent manufacturer shown in Table 7.13b. The portion of this venting within the B-vent is flexible.
  - All flex pipe must be installed vertically. Up to two offsets (four bends) may be made in the vertical run of flex pipe. Bends used to make these offsets may not exceed 45 degrees.
  - Because the flex pipe is corrugated, it has a higher pressure drop than the rigid pipe used elsewhere in the vent system. Equivalent lengths for flex venting are shown in Table 7.14. Reduce the maximum allowable vent length shown in Table 7.13b by this equivalent length for each foot of flex pipe used, as well as for each elbow in addition to the first. The termination is not counted. If offsets (described above) are present, the equivalent length of the bends in these offsets can also be ignored.

*Example: A 135MBH model is to be installed as using Vent Option 9 as shown in Figure 7.19. The following components are used:*

*Vent:*

*3" DuraVent Poly-Pro (Rigid) – 4ft*

*3" DuraVent Poly-Pro Flex – 20ft*

*Poly-Pro elbows – 2*

*DuraVent 3PPS-VFT Terminal (exhaust side)*

*Intake:*

*3" PVC – 6ft*

*3" PVC Sweep 90 – 3*

*Turn in B vent Tee*

*Straight B-vent (6" or larger) containing flex vent – 20ft*

*DuraVent 3PPS-VFT Terminal (intake side)*

*Vent Equivalent length – First elbow is ignored. The terminal is also ignored. From Table 7.14, the equivalent length of 3" DuraVent Poly-Pro Flex is 2.0ft. From Table 7.1 the equivalent length of the second 90 elbow is 8.7ft. The equivalent length of the vent system is therefore:*

$$4 + 8.7 + (20 \times 2.0) = 52.7\text{ft.}$$

*Since Vent Option 9 shows a max vent length of 135ft, the planned vent length of OK.*

*Intake Equivalent length - First elbow and the turn in the B vent tee are ignored, leaving two sweep 90 elbows that must be counted. From Table 7.1, the equivalent length of each of these elbows is 4.0ft. From Table 7.14 the equivalent length of the B vent containing flex is 1.0ft. Equivalent length of the intake system is therefore:*

$$(2 \times 4.0) + 6 + (20 \times 1.0) = 34.0\text{ft.}$$

*Since this is less than 135ft, the planned intake length is OK.*

**VII. Venting C. Design Requirements Unique to Vertical Venting Systems (continued)**

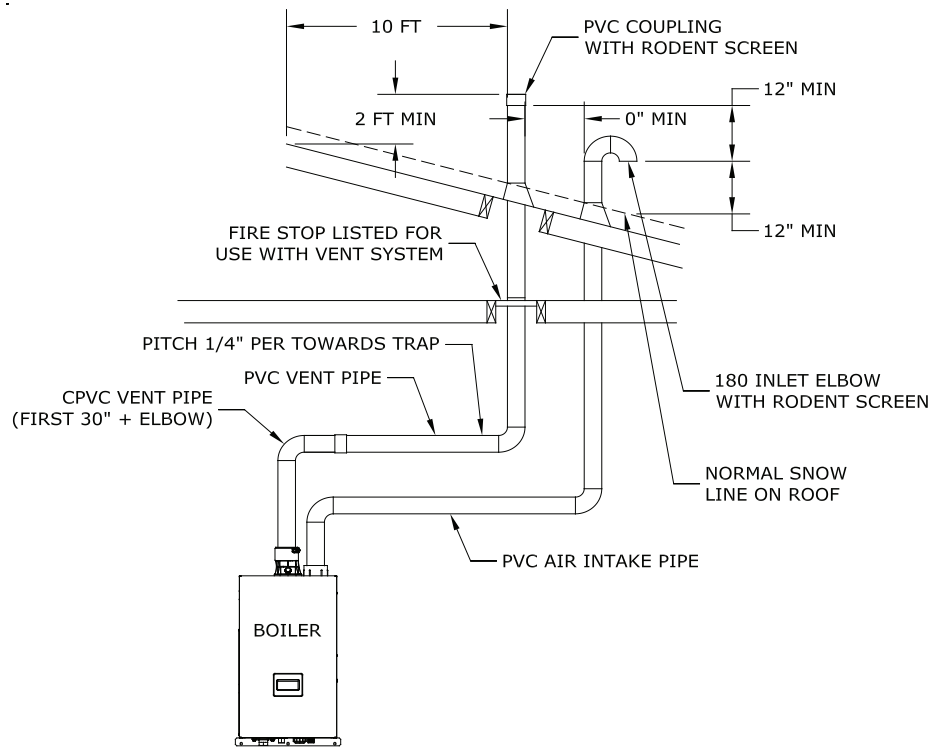
**Table 7.14: Equivalent Length of Flex Pipe**

	Equivalent Length (ft)
Flex Vent (1 ft):	
3" DuraVent PolyPro Flex	2.0 ft
3" Centrotherm InnoFlue Flex	2.3 ft
3" Selkirk Polyflue	2.3 ft
3" Duravent FasNSeal Flex	1.0 ft
B-Vent Air Chase (1ft):	
3" Flex Vent in 6" (or larger) B-Vent	1.0 ft

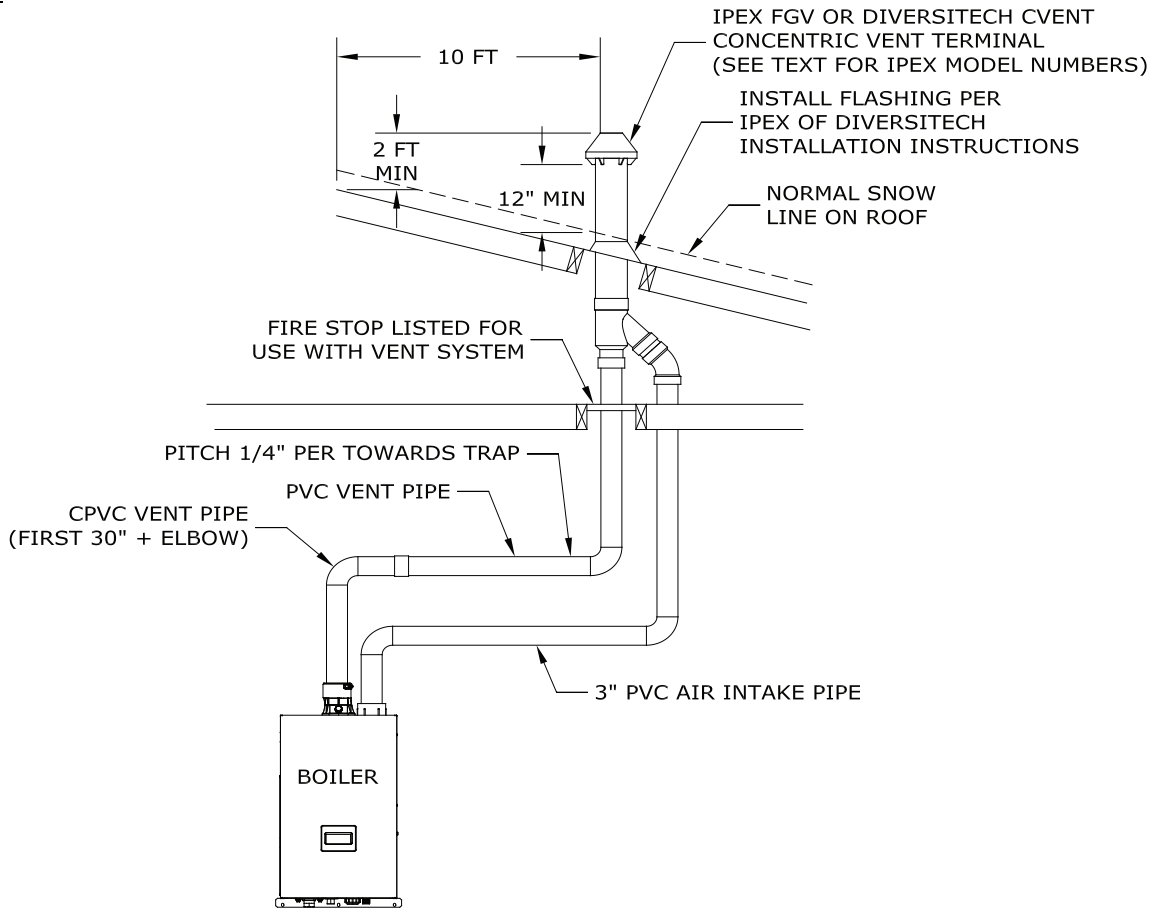
Note: Up to four 45 degree bends may be made in flex pipe or air chase. These bends are not counted when figuring equivalent length.



**VII. Venting C. Design Requirements Unique to Vertical Venting Systems (continued)**

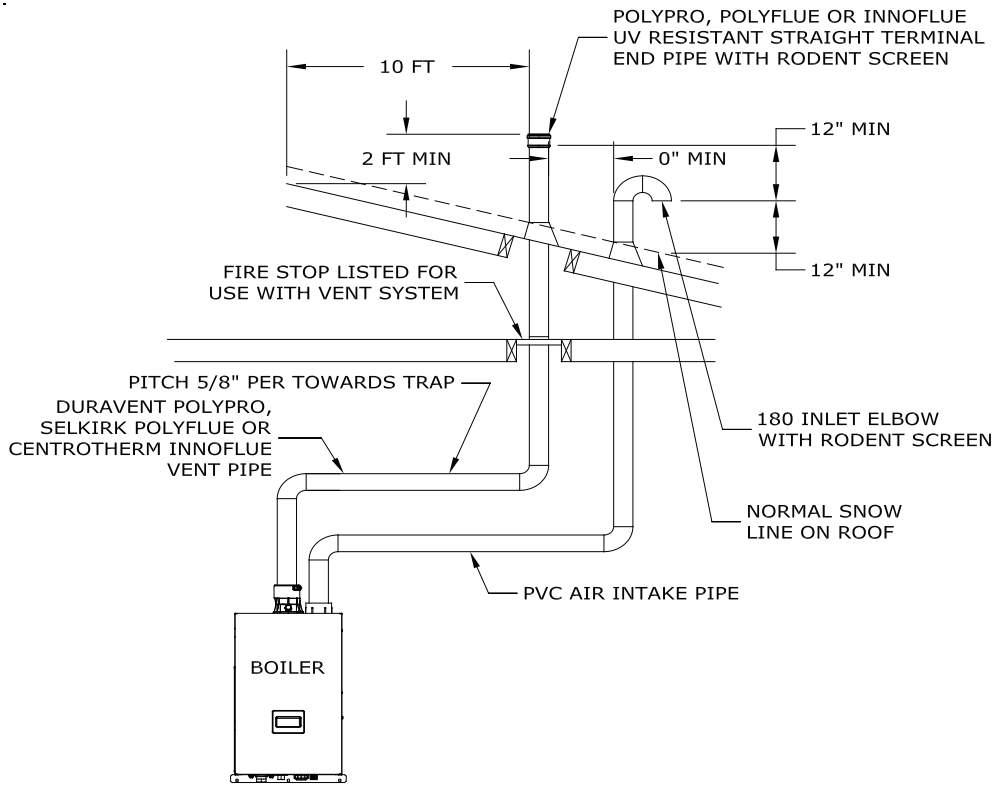


**Figure 7.15: Vertical CPVC/PVC Venting (Vent Option 5, Terminal Option H)**

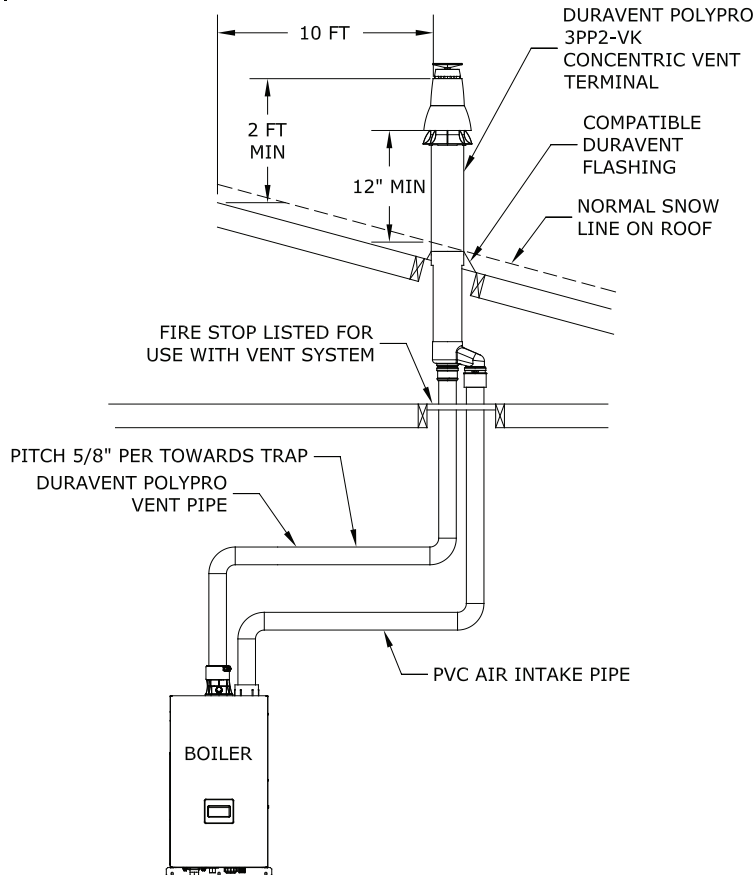


**Figure 7.16: Vertical CPVC/PVC Venting with IPEX Concentric Vent Terminal (Vent Option 5, Terminal Option I, J)**

**VII. Venting C. Design Requirements Unique to Vertical Venting Systems (continued)**



**Figure 7.17: DuraVent PolyPro, Selkirk Polyflue or Centrotherm InnoFlue Vertical Single Wall PP Venting (Vent Options #6-8, Terminal Option H)**



**Figure 7.18: DuraVent PolyPro Vertical Venting with Concentric Terminal (Vent Option #6, Terminal Option K)**

## VII. Venting C. Design Requirements Unique to Vertical Venting Systems (continued)

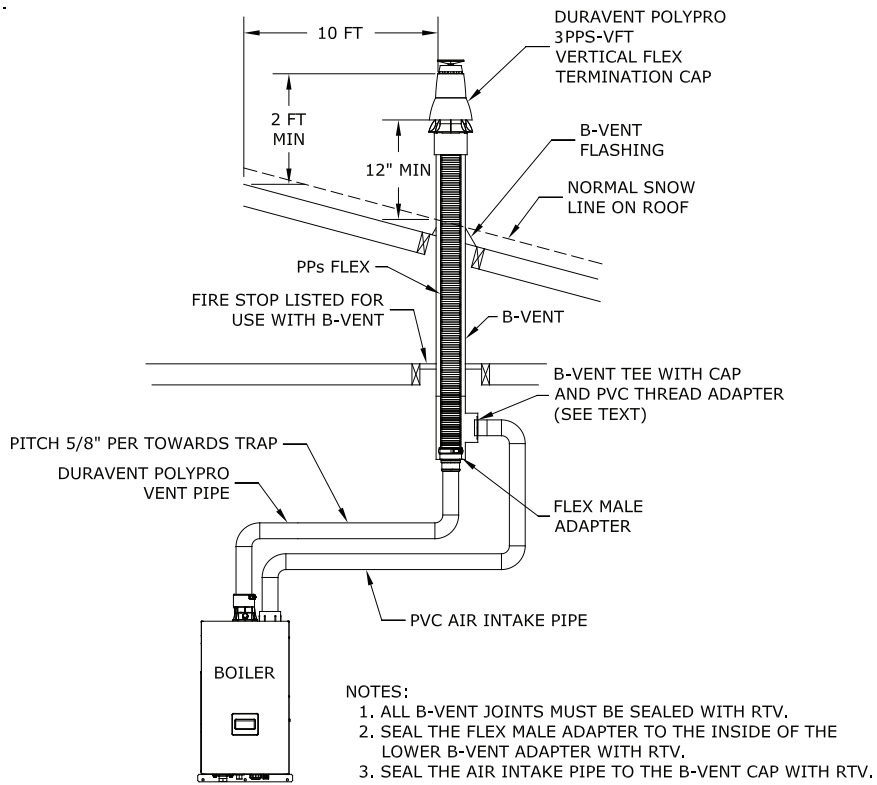


Figure 7.19: Duravent PolyPro B-Vent Air Chase System (Vent Option #9)

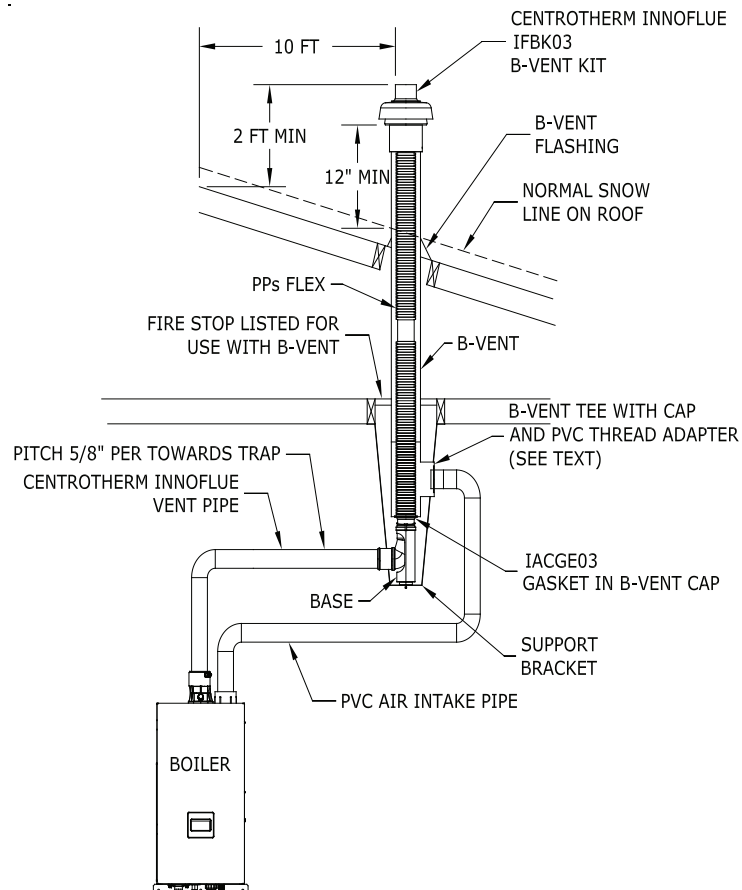


Figure 7.20: Centrotherm InnoFlue B-Vent Air Chase System (Vent Option #10)

## VII. Venting D. Design Requirements Unique to Split Vent Systems (continued)

### D. Design Requirements Unique to Split Vent Systems

Table 7.21 summarizes all split vent options. Illustrations of split vent systems are shown in Figures 7.22, 7.23, 7.24a and 7.25a. In addition to the requirements in Section VII - A, observe the following design requirements:

#### 1. Permitted Terminals for Split Venting:

Rigid Vent Systems (Vent Options 11-14) – Vent terminates in a plain end (coupling for PVC, bell end for PolyPro, Polyflue, and plain end pipe for InnoFlue). Intake terminates in a PVC 90 sweep elbow pointing down. The section of PolyPro, Polyflue or InnoFlue exposed to the outdoors must be UV resistant.

Use of rodent screens (not supplied) is generally recommended for both terminations. These can be fabricated from 2 x 2 (1/2" mesh) stainless steel screen. Rodent screens are installed as shown in Figure 7.28. Rodent screens are installed as shown in Figure 7.28. Rodent screens ("bird guards") for PolyPro, Polyflue and InnoFlue are as follows:

Size/Vent System	Rodent Screen ("Bird Guard")
3" PolyPro	DuraVent # 3PPS-BG
3" Polyflue	Selkirk #3PF-HVST
3" InnoFlue	Centrotherm # IASPP03

Flex Vent Terminals (Options 15-18) – The flex vent kits shown for options 15-18 include vent terminals that must be installed in accordance with the vent manufacturer's instructions. In some cases, different terminals are used for Masonry and B-vent chimney chases.

Air Intake Terminals (Vent Options 11-18) - All split venting options shown in Tables 7.21 terminate in a PVC 90 sweep elbow pointing down. Use of rodent screens (not supplied) is generally recommended for both terminations. These can be fabricated from 2 x 2 (1/2" mesh) stainless steel screen. Rodent screens are installed as shown in Figure 7.28.

#### 2. Vent Terminal Location – Observe the following clearances from roof mounted vent terminals (also see Figures 7.22, 7.23, 7.24a or 7.25a):

- Bottom of terminal must be at least 12" above the normal snow line anticipated on the roof.
- Exhaust opening must be at least 2ft above any portion of the roof or structure located within horizontally within 10ft.

#### 3. Horizontal Air Intake Terminal Location - Observe the following limitations on the intake terminal location (also see Figures 7.22, 7.23, 7.24a, and 7.25a):

- The bottom of all terminals must be at least 12" above the normal snow line. In no case should they be less than 12" above grade level.
- If possible, install the intake terminal on a wall away from the prevailing wind. Reliable operation of this boiler cannot be guaranteed if the intake terminal is subjected to winds in excess of 40 mph.
- Air intake terminal must not terminate in areas that might contain combustion air contaminants, such as near swimming pools. See WARNING on page 13.

#### 4. Use of abandoned chimneys as a Vent Chase for flexible Polypropylene Venting (Options 15-17) – Vent options 15-17 permit flexible Polypropylene venting to be routed to the roof using an abandoned masonry or B-vent chimney. In these applications combustion air is drawn horizontally from a wall terminal. See Figure 7.23 or 7.24a. When using one of these vent options, observe the following requirements:

- When a masonry chimney containing multiple flues is used as a chase, ALL flues must be abandoned (Figure 7.24b).
- Masonry or B vent chimney used as a chase must be structurally sound and in good repair.
- Use of flex Polypropylene outside of a masonry or B-vent chimney is not permitted unless allowed by the vent manufacturer and permitted by local codes.
- All venting is Polypropylene supplied by the vent manufacturer shown in Table 7.21. The portion of this venting within the masonry or B-vent chimney is flexible.
- All flex pipe must be installed vertically. Up to two offsets (four bends) may be made in the vertical run of flex pipe. Bends used to make these offsets may not exceed 45 degrees (Figure 7.24b).
- Because the flex pipe is corrugated, it has a higher pressure drop than the rigid pipe used elsewhere in the vent system. Equivalent lengths for flex venting are shown in Table 7.14. Reduce the maximum allowable vent length shown in Table 7.21 by this equivalent length for each foot of flex pipe used, as well as for each elbow in addition to the first. The first elbow and termination are not counted. If offsets (described above) are present, the equivalent length of the bends in these offsets can also be ignored.

## VII. Venting D. Design Requirements Unique to Split Vent Systems (continued)

5. Use of abandoned chimney as vent chase for flexible Stainless Steel venting (option 18) - Vent option 18 permits flexible Stainless Steel venting to be routed to the roof using an abandoned masonry type chimney. In this application, combustion air is drawn horizontally from a wall terminal. See Figure 7.25a. When using one of these options, observe the following requirements:
- When a masonry chimney containing multiple flues is used as a chase, the flexible stainless vent installation is permitted through an adjacent UNUSED flue providing local authority having jurisdiction approves such installation. (Figure 25b)
  - Masonry chimney used as a chase must be structurally sound and in good repair.
  - All venting is stainless steel supplied by the vent manufacturer shown in Table 7.21. The portion of this venting within the masonry or B-vent chimney is flexible.
  - When flexible stainless steel is used for combustion product venting, it must be installed at vertical or near vertical plane. This will insure proper condensate flow back to the boiler. (Figure 25a)

*Example: A 135MBH model is to be installed as using Vent Option 15 in a masonry chimney as shown in Figure 7.24a. The following components are used:*

*Vent:*

*3" DuraVent Poly-Pro (Rigid) – 4ft*

*3" DuraVent Poly-Pro Flex – 30ft*

*Poly-Pro elbows – 2 (one at base of chimney and one above boiler)*

*DuraVent 3PPS-FK Terminal*

*Intake:*

*3" PVC – 6ft*

*3" PVC Sweep 90 – 2 (one above the boiler and one as an intake terminal)*

*Vent Equivalent length – First elbow is ignored. The terminal is also ignored. From Table 7.14, the equivalent length of 3" DuraVent Poly-Pro Flex is 2.0ft. From Table 7.1 the equivalent length of the second 90 elbow is 8.7ft. The equivalent length of the vent system is therefore:*

$$4 + 8.7 + (30 \times 2.0) = 72.7\text{ft.}$$

*Since Vent Option 15 shows a max vent length of 135ft, the planned vent length of OK.*

*Intake Equivalent length - First elbow and termination elbow are ignored, leaving just the straight pipe. Equivalent length of the intake system is therefore 6ft. Since this is less than 135ft, the planned intake length is OK.*



### **WARNING**

**Asphyxiation Hazard. Flexible polypropylene vent must be installed only in an UNUSED chimney. A chimney flue is considered UNUSED when it is not being used for any appliance venting. If chimney is a multiple flue type where one of the multiple flues is being used for an appliance venting, the flexible vent installation is not permitted through any of the adjacent flues.**

**Asphyxiation Hazard. Flexible stainless steel vent must be installed only in an UNUSED chimney flue. A chimney flue is considered UNUSED when it is not being used for any appliance venting. If chimney is a multiple flue type where one of the multiple flues is being used for an appliance venting, the flexible stainless steel vent installation is permitted through an adjacent, unused flue providing a local authority having jurisdiction approves such installation.**

## VII. Venting D. Design Requirements Unique to Split Vent Systems (continued)

**Table 7.21: Summary of Split Vent System Options**

Option #		11	12	13	14	15	16
Illustrated in Figure		7.22	7.22	7.22	7.22	7.23, 7.24	7.23, 7.24
Pipe Penetration Through Structure	Vent	Roof	Roof	Roof	Roof	Roof	Roof
	Intake	Wall	Wall	Wall	Wall	Wall	Wall
Material	Vent	CPVC/PVC (Note 2)	DuraVent PolyPro (Rigid)	Selkirk Polyflue	Centrotherm InnoFlue SW	DuraVent PolyPro (Rigid/Flex)	Selkirk Polyflue (Rigid/Flex)
	Intake	PVC	PVC	PVC	PVC	PVC	PVC
Nominal Diameter	Vent	3"	3"	3"	3"	3"	3"
	Intake	3"	3"	3"	3"	3"	3"
Min Equivalent Vent Length:							
Models	135	48"	48"	48"	48"	48"	48"
	150	52"	52"	52"	52"	52"	52"
	180	52"	52"	52"	52"	52"	52"
Max Equivalent Vent Length (Note 1):							
Models	135	135ft	135ft	135ft	135ft	135ft	135ft
	150	135ft	135ft	135ft	135ft	135ft	135ft
	180	135ft	135ft	135ft	135ft	135ft	135ft
Rigid Vent Terminals	Vent	Coupling w/Screen	3PPS-12B or 3PPS-36B w/Screen	3PF-10UV or 3PF-39UV w/Screen	ISEP03 or ISEP0339 w/Screen	Not Permitted	
	Intake	90 Elbow w/Screen	90 Elbow w/Screen	90 Elbow w/Screen	90 Elbow w/Screen		
Flex Termination & Components (Masonry Chimney Chase) (Note 3)	Vent	Not Permitted				3PPS-FK	3PF-FLEX-KIT
	Intake					3PPS-FLEX**	3PF-FLEX
Flex Termination & Components (B-Vent Chimney Chase)	Vent	Not Permitted				90 Elbow w/Screen	90 Elbow w/Screen
	Intake					3PPS-VFT	3PF-10UV or 3PF-39UV w/Screen
					3PPS-BF*	3PF-39UV w/Screen	
					3PPS-FLEX**	3PF-BVSC (Note 3)	
					90 Elbow w/Screen	90 Elbow w/Screen	

\* Specify size of B vent (e.g. 3PPS-BV6 is for use with 6" B vent).

\*\* Specify length in feet.

Note 1: Max vent lengths shown also apply to the intake. Flex vent reduces the maximum allowable vent length in some applications. See equivalent lengths for flex vent shown in Table 7.14 and sizing example on page 32.

Note 2: First 30" plus first exhaust elbow are CPVC.

Note 3: See Polyflue installation manual for gaskets, spacers and other required vent components.

**All vertical terminals require compatible roof flashing and storm collars.**

## VII. Venting D. Design Requirements Unique to Split Vent Systems (continued)

**Table 7.21: Summary of Split Vent System Options (cont.)**

Option #		17	18
Illustrated in Figure		7.23, 7.24	7.23, 7.24
Pipe Penetration Through Structure	Vent	Roof	Roof
	Intake	Wall	Wall
Material	Vent	Centrotherm Innoflue (Ridgid/Flex)	DuraVent FasNSeal (Stainless, Ridgid/Flex)
	Intake	PVC	PVC
Nominal Diameter	Vent	3"	3"
	Intake	3"	3"
Min Equivalent Vent Length:			
Models	135	48"	48"
	150	52"	52"
	180	52"	52"
Max Equivalent Vent Length (Note 1):			
Models	135	135ft	135ft
	150	135ft	135ft
	180	135ft	135ft
Rigid Vent Terminals	Vent	Not Permitted	
	Intake		
Flex Termination & Components (Masonry Chimney Chase)	Vent	IFCK03**	2SVSCKIT03** 2SVFLXCN03**
	Intake	90 Elbow w/Screen	90 Elbow w/Screen
Flex Termination & Components (B-Vent Chimney Chase)	Vent	IFBK03****	2SVFLXR03
	Intake	90 Elbow w/Screen	90 Elbow w/Screen

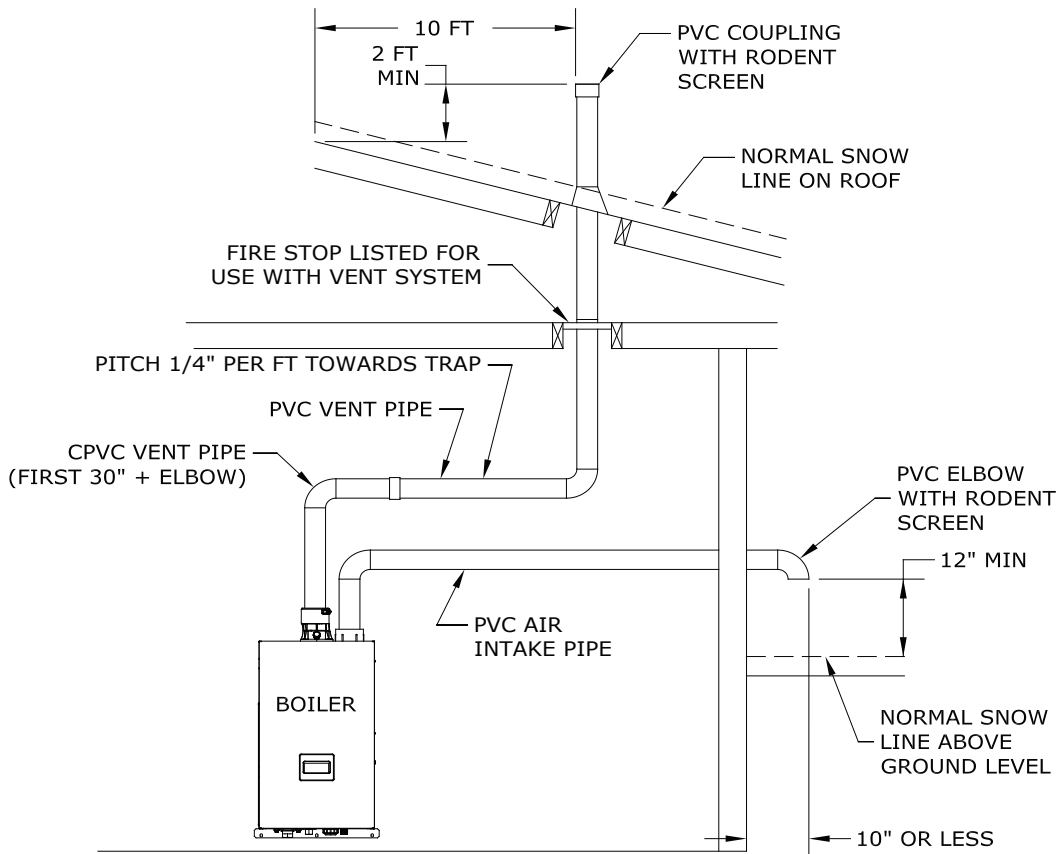
\*\* Specify length in feet.

\*\*\*\* Specify Flex length and B vent diameter (e.g. IFBK032506 includes 25ft of flex and used with 6" B vent).

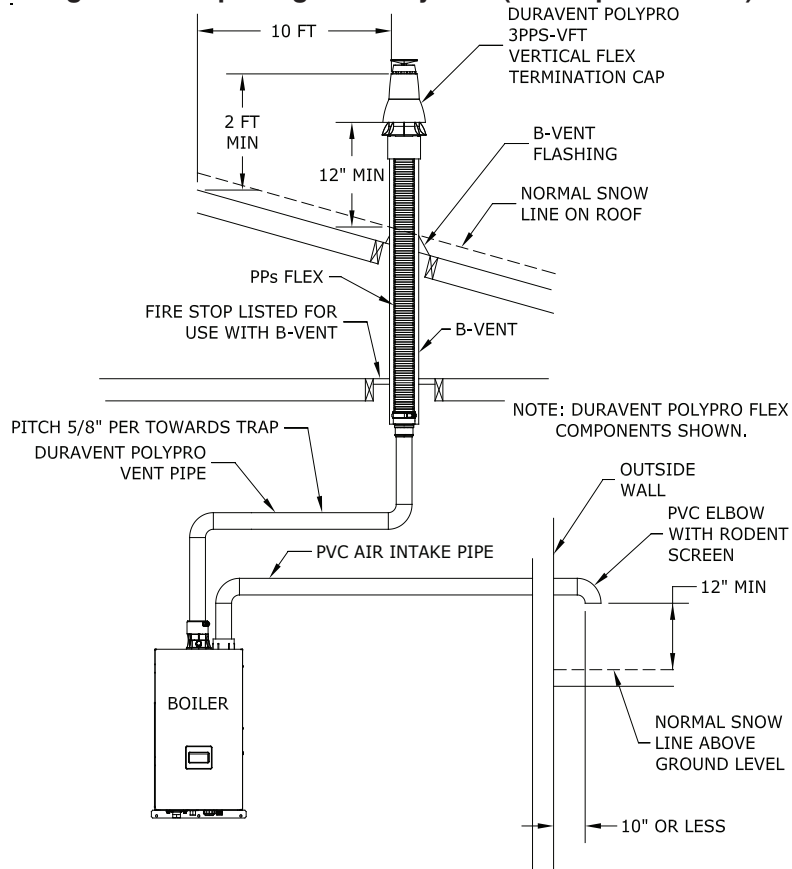
Note 1: Max vent lengths shown also apply to the intake. Flex vent reduces the maximum allowable vent length in some applications. See equivalent lengths for flex vent shown in Table 7.14 and sizing example on page 32.

**All vertical terminals require compatible roof flashing and storm collars.**

**VII. Venting D. Design Requirements Unique to Split Vent Systems (continued)**



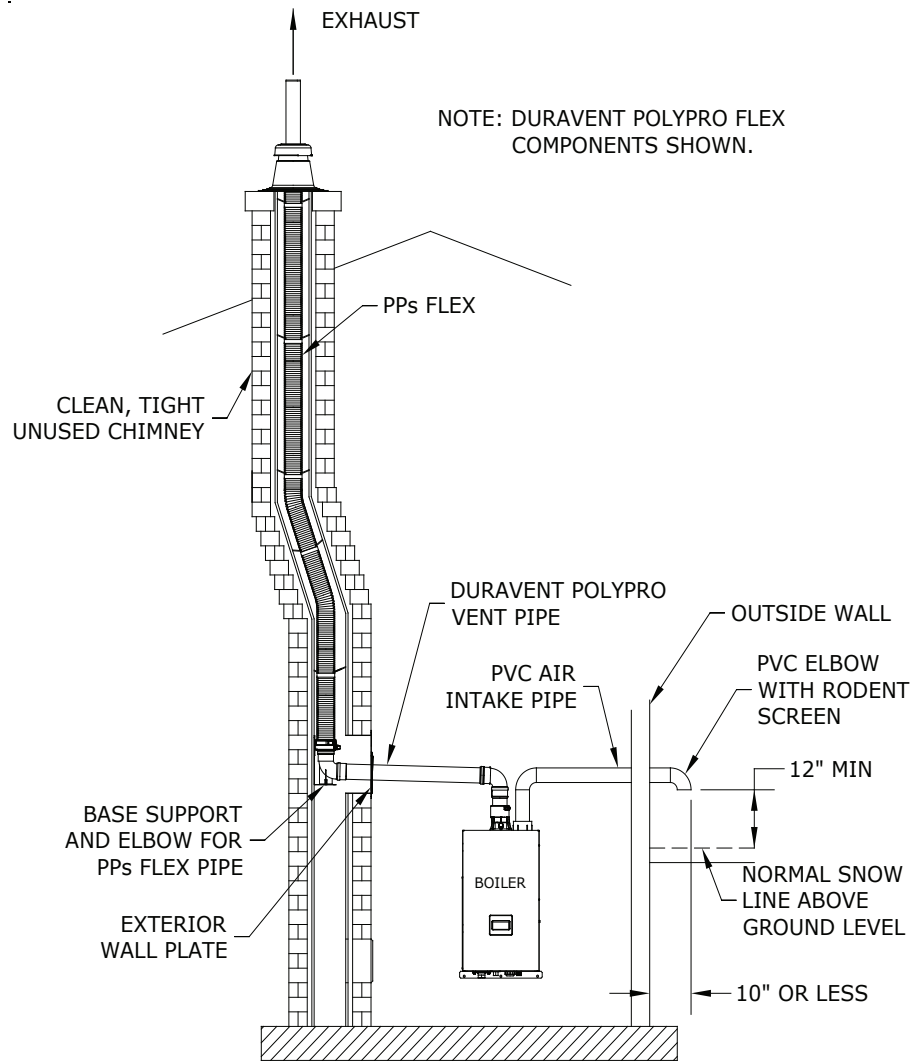
**Figure 7.22: Split Rigid Vent System (Vent Options 11-14)**



**Figure 7.23: Split Vent System (Flex in B-Vent Chase) Vent Options 15-17)**



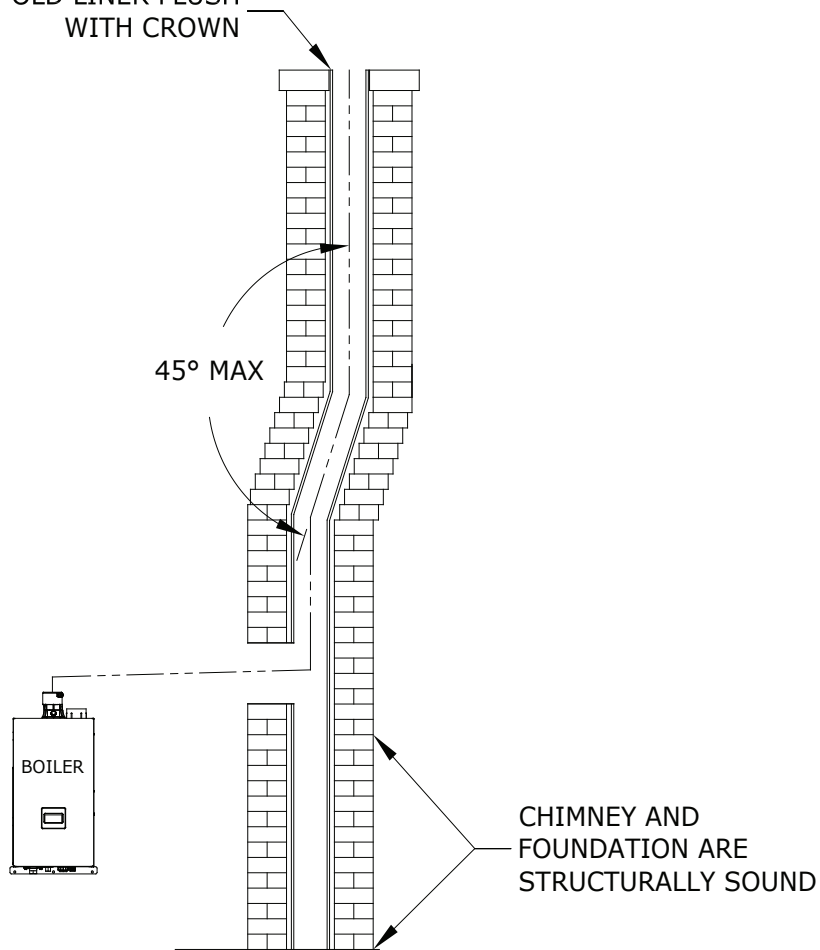
**VII. Venting D. Design Requirements Unique to Split Vent Systems (continued)**



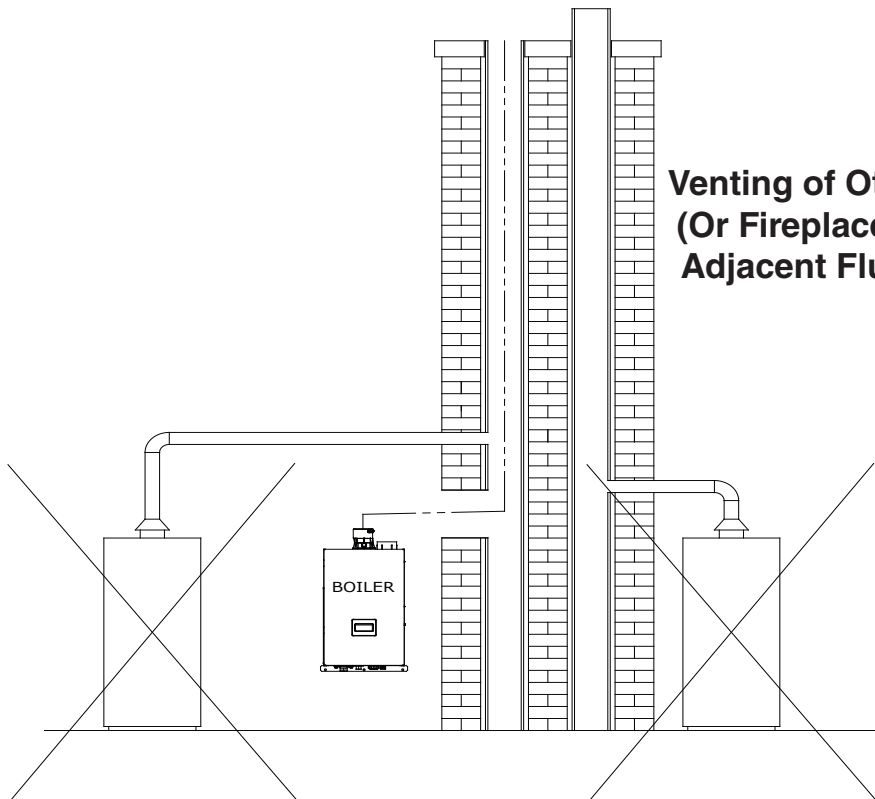
**Figure 7.24a: Split Vent System (PP Flex in Abandoned Masonry Chimney) (Vent Options 15-17)**

**VII. Venting D. Design Requirements Unique to Split Vent Systems (continued)**

TRIM OLD LINER FLUSH WITH CROWN

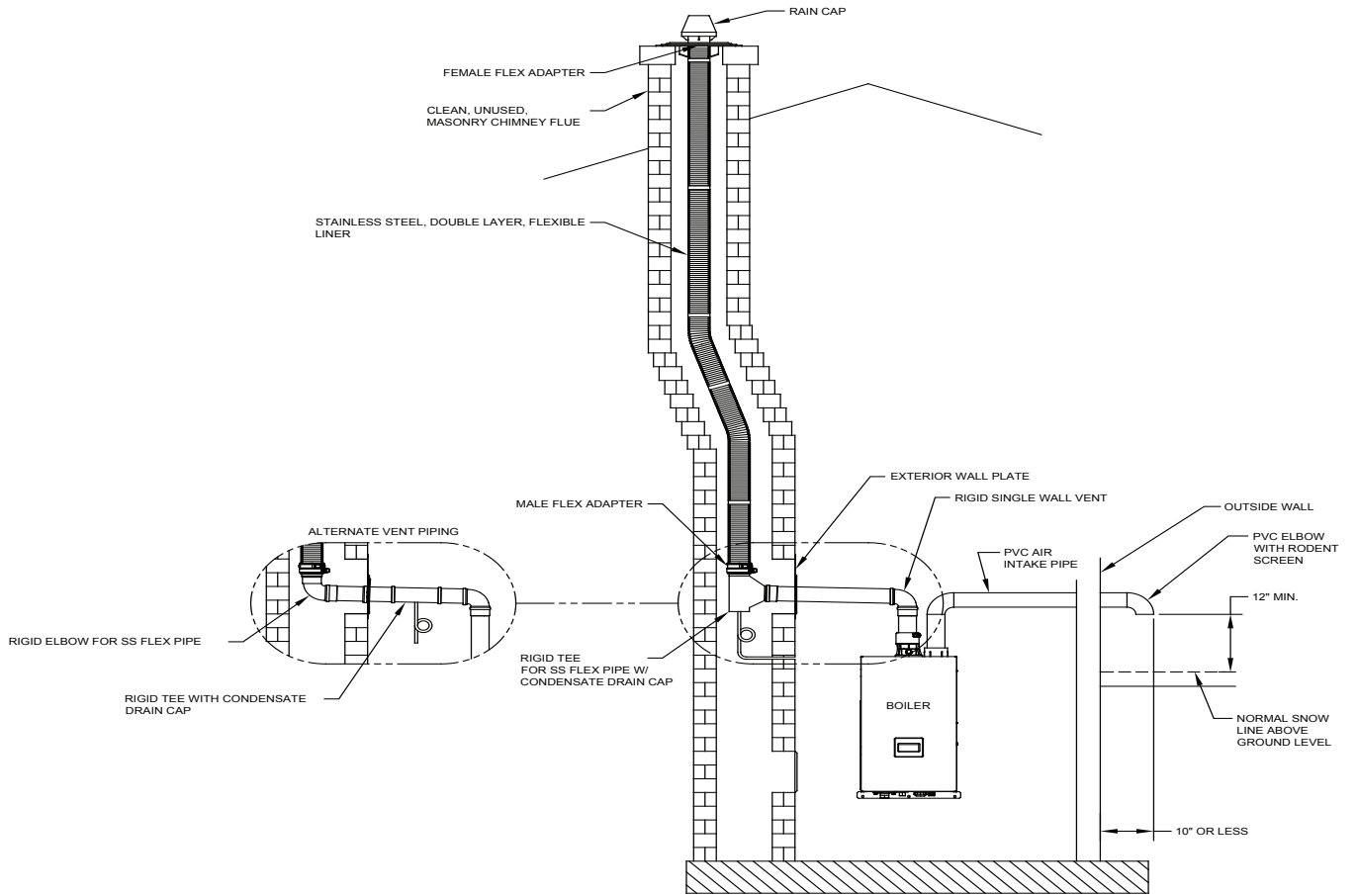


**Venting of Other Appliances (Or Fireplace) into Chase or Adjacent Flues Prohibited!**

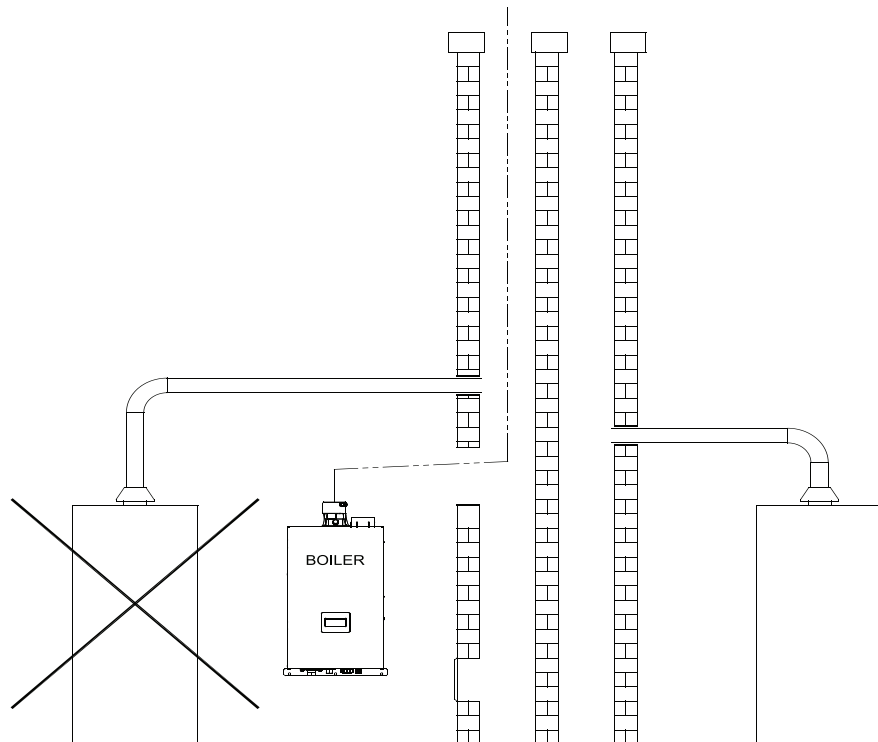


**Figure 7.24b: Flexible PP Masonry Chimney Chase Requirements**

**VII. Venting D. Design Requirements Unique to Split Vent Systems (continued)**



**Figure 7.25a: Split Vent Systems (SS Flex in Abandoned Masonry Chimney) (Vent Option 18)**



**Figure 7.25b: Flexible SS Masonry Chimney Chase Requirements**

## VII. Venting E. Assembly of CPVC/PVC Vent Systems (continued)

### E. Assembly of CPVC/PVC Vent Systems



#### **WARNING**

**Asphyxiation Hazard. Failure to follow these instructions could cause products of combustion to enter the building, resulting in severe property damage, personal injury or death.**

**Use all CPVC vent components for near-boiler vent piping before transitioning to Schedule 40 PVC pipe (ASTM 2665) components for remainder of vent system.**

**Use CPVC vent components within any interior space where air cannot circulate freely, including through vertical or horizontal chase ways, inside a stud wall, in closets and through wall penetrations.**

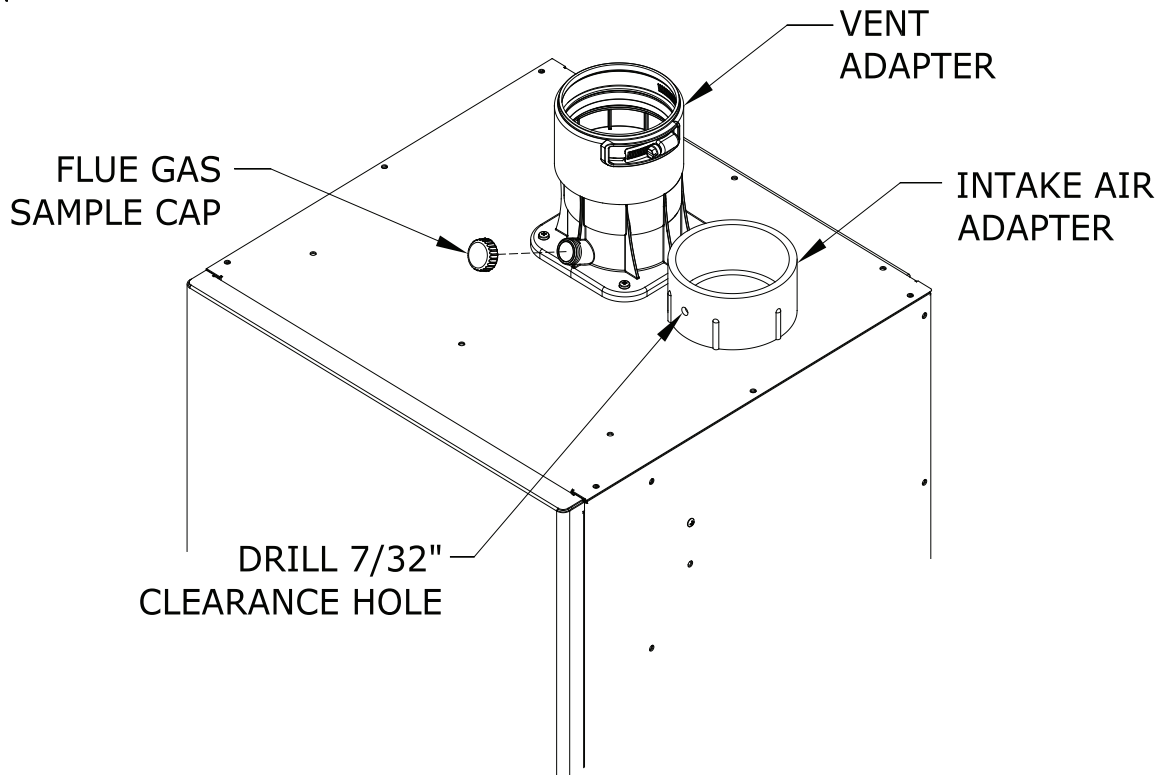
**The use of cellular core PVC (ASTM F891), cellular core CPVC or Radel (polyphenolsulfone is prohibited.**

**All condensate that forms in the vent must be able to drain back to the boiler.**

**Never leave the boiler in operation without the gas sample cap in place (Figure 7.27).**

1. Assemble the vent system, starting at the boiler:
  - a. If 3" PVC is to be used for venting, a 3" CPVC elbow and the 30" straight section of CPVC must be used before transitioning to PVC. If necessary the 30" straight section of CPVC may be cut at any location and a CPVC elbow can be inserted between the two resulting segments.
  - b. When cutting CPVC or PVC pipe, use a miter saw or a saw designed to cut PVC pipe. Use a miter box or other method to cut pipe squarely. De-burr both the inside and outside of the cut end.
  - c. Dry fit all vent components before assembly.
  - d. The vent adaptor has three different inside diameters. The larger (upper) inside diameter accepts 3" CPVC pipe and is used in this application (the middle inside diameter accepts 3" nominal PolyPro, Polyflue or InnoFlue, and the smaller, lower inside diameter accepts 3" stainless steel). A locking band clamp in the adaptor prevents the vent pipe from coming out of the adaptor once it is installed and tightened. Lubricate the upper gasket in the vent adaptor with water and insert the first piece of 3" CPVC into the vent adaptor until it bottoms out. Tighten locking band clamp to secure vent pipe.
  - e. Assemble a 3" CPVC elbow and remainder of 30" CPVC piping before transitioning to PVC. If 3" PVC is used, the first piece of PVC will either be connected to the CPVC elbow or the end of a section of CPVC vent pipe. In the latter case, a PVC coupling may be used to connect the first piece of PVC to the last piece of CPVC.
  - f. Clean all CPVC and PVC components with the appropriate primer before cementing. Cement the vent system together, starting at the boiler and following the instructions provided on the cans of cement and primer. Use a field supplied cement and primer that is listed for use with the materials being joined (CPVC and/or PVC). The following, or its equivalent, may be used to join CPVC to PVC:
    - IPS Corporation #P-70 Primer
    - IPS Corporation #790 Multi-Purpose Solvent CementAlways use primer on both the pipe and fitting before applying the cement. Assemble the pipe in accordance with the instructions on the cans of primer and cement.
  - g. Assemble the rest of the vent system, being sure to pitch horizontal sections back towards the boiler 1/4"/ft. Support the vent at intervals not exceeding 4ft.
  - h. Maintain the clearances from the vent pipe outlined in Section VII - A of this manual. If exiting the exterior wall using PVC pipe, use half of an appropriately sized wall thimble (or a sheet metal plate) on the exterior of the building, to provide a weather tight seal while maintaining the proper clearance in the wall penetration. Seal the joint between the pipe and the wall plate using RTV applied on the exterior side of the wall. This sealant must not restrain the expansion of the vent pipe.
2. Installation of Air Intake System - Start assembly of the PVC air intake system at the boiler. Assembly of the air intake system is done in the same manner as the vent system except as follows:
  - a. Drill a 7/32" clearance hole into the front side of the air intake adapter. Insert the first piece of PVC air intake pipe into the air intake connection and drill a 1/8" tap hole into the PVC which lines up with the 7/32" clearance hole and secure them together with a #10 x 1" sheet metal screw. Seal the joint between the intake pipe and the adaptor with RTV.
  - b. All intake piping may be PVC.

## VII. Venting E. Assembly of CPVC/PVC Vent Systems (continued)



**Figure 7.27: Vent Connections and Flue Gas Sample Cap Location**

- c. There is a 0" minimum clearance between the air intake piping and all types of construction.
- d. To the extent possible, pitch horizontal air intake piping towards the outdoors.
3. Installation of Horizontal Fitting Terminals (Terminal Option A):
  - a. See Figure 7.28 for proper orientation of twin pipe horizontal terminals. Outer edge of both terminals must be within 10" from wall surface. (Figure 7.6)
  - b. If desired, the terminals can be attached to the end of the vent and/or intake pipes with field supplied stainless steel screws so that they can be later removed for cleaning and inspection. If this is done, drill a clearance hole in the coupling or elbow and a tap hole in the end of the vent/intake pipes to accept these screws.
  - c. If these terminals are installed on snorkels, assemble the snorkels as shown in Figure 7.12. Brace the vertical run of piping on the building exterior as required.
4. Installation of Vertical Fitting Terminals (Terminal Option H):
  - a. See Figure 7.29 for the proper orientation of twin pipe vertical terminals.
  - b. The coupling is used to secure the rodent screen to the end of the vent pipe.
  - c. A 180° bend (or two 90° elbows) are installed on the top of the air intake pipe. If two 90° elbows are used, a rodent screen can be installed between them (Figure 7.29). If a 180° bend is used, install a rodent screen in the open side of the bend, using a ring made of PVC pipe. If desired, the termination fittings can be attached to the end of the vent and/or intake pipes with field supplied stainless steel screws so that they can be later removed for cleaning and inspection. If this is done, drill a clearance hole in these fittings and a tap hole in the end of the vent/intake pipes to accept these screws.
  - d. Use roof flashings and storm collars to prevent moisture from entering the building. Seal the roof flashing to the roof using generally accepted practice for the type of roof on the installation. Apply RTV to seal the storm collars to the vent and intake pipes.
5. Installation of IPEX low profile vent terminal (Terminal Option B) - See Figure 7.30:
  - a. Cut two holes in wall to accommodate the size PVC pipe being used. The distance between hole centers is 5.6".
  - b. Slide both vent and intake air pipes through the holes, and cement them to the base of the vent termination kit using a primer and cement listed for use with PVC.

VII. Venting E. Assembly of CPVC/PVC Vent Systems (continued)

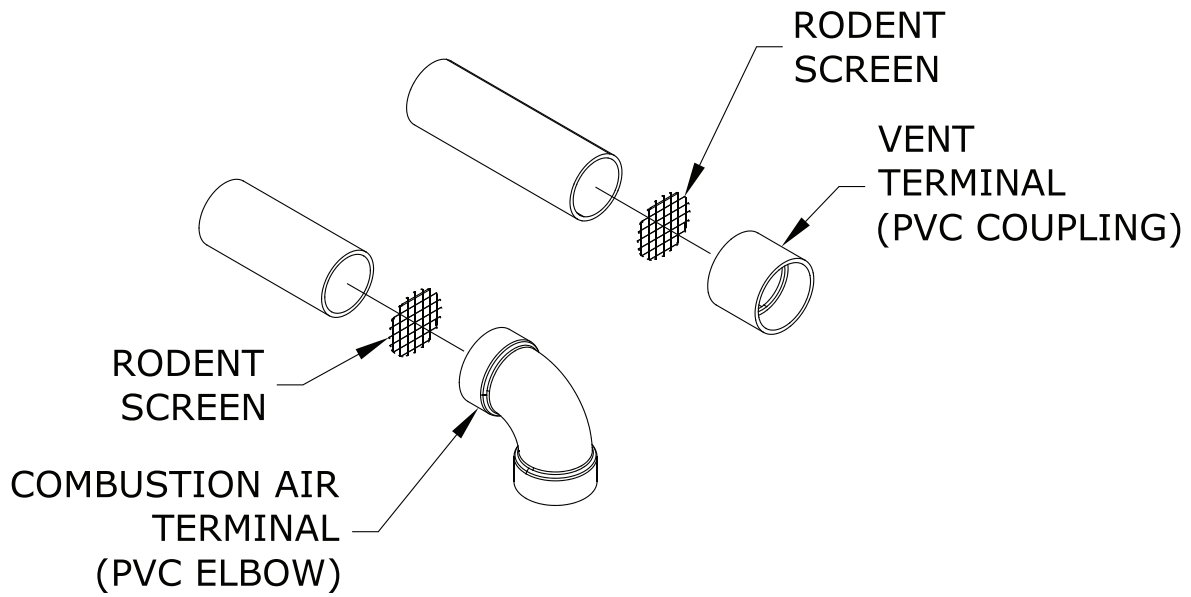


Figure 7.28: Installation of Standard Horizontal Terminals

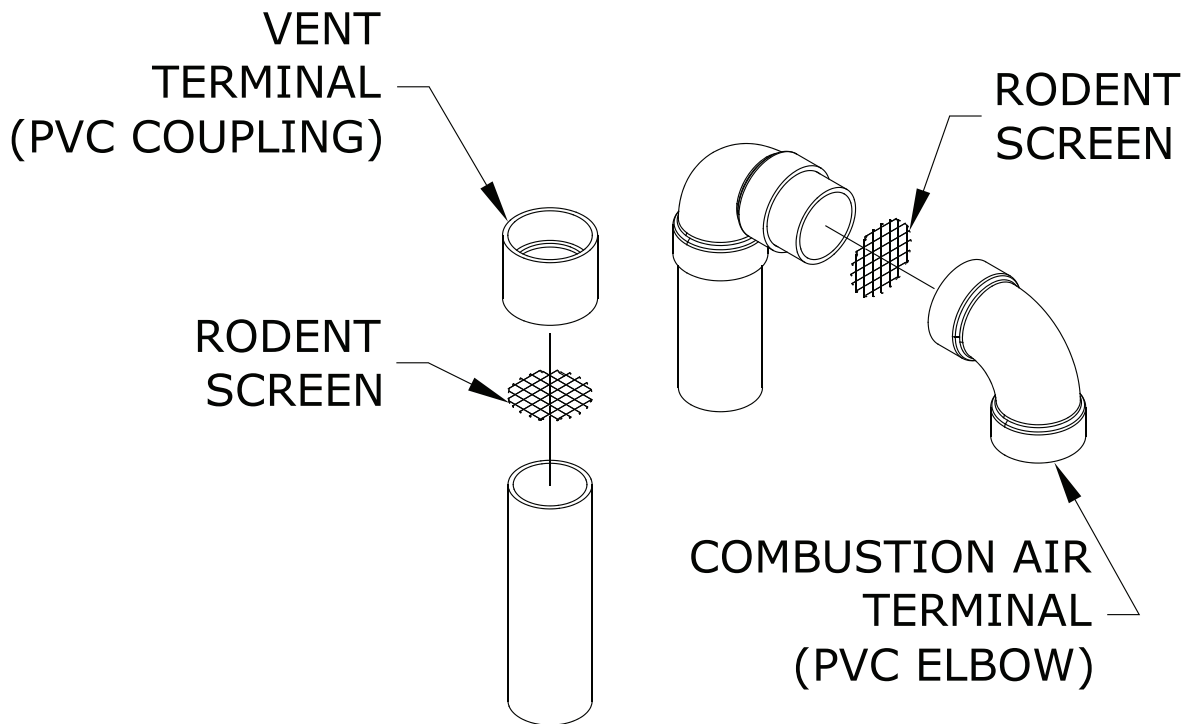


Figure 7.29: Installation of Standard Vertical Terminals

## VII. Venting E. Assembly of CPVC/PVC Vent Systems (continued)

- c. Fasten the vent base to the wall using the supplied screws and anchors. The anchors require the drilling of a 3/16" hole x 1-3/16" deep. Locate the holes using the vent base as a template.
  - d. Screw the vent cap to the vent base using the supplied screws.
  - e. Once the vent termination and pipes are secure seal the wall penetrations from the interior using a weather resistant RTV sealant.
6. Installation of DiversiTech Low Profile Terminal (Terminal Option C) – See Figure 7.31:
- a. Use vent plate as a guide to locate the openings for the vent and air intake pipes, as well as to locate the holes for the mounting screws.
  - b. Drill two 3-1/8 holes through the wall for the vent and intake pipes.
  - c. Drill four 3/16 holes for the mounting screws.
  - d. Install the vent and intake pipe sections passing through the wall. Cut the pipes so that they protrude the following distances from the surface on which the vent plate will be mounted:
    - Vent: Between 1-3/4 and 2-1/4"
    - Intake: Between 1/4 and 1"
  - e. Seal pipe penetrations in wall with RTV (silicone sealant).
  - f. Mount the vent plate using the #8 x 2" screws and anchors provided with this kit.
  - g. Seal the vent plate to the wall with RTV.
  - h. Apply a bead of RTV around the OD of the vent pipe near its end.
  - i. Slide the vent cap over the vent pipe and secure to the wall plate with the #8 x 2" screws provided.
7. Installation of IPEX FGV or DiversiTech CVENT Concentric Vent Terminal (Terminal Options D,E,I & J) - This terminal may be used for either horizontal or vertical venting. See Figure 7.33 for horizontal installation or Figure 7.34 for vertical installation. When PVC is used for venting, a 30" CPVC straight section and CPVC elbow must be used prior to connection of the vent system to this terminal. If the vent system is too short to permit this, use the IPEX FGV CPVC terminal:
- a. For horizontal installations at the planned location cut a round hole in the exterior wall 1/2" larger than the "C" dimension indicated on Figure 7.32 for the size terminal being used. (See Section VII - B of this manual for permitted terminal locations).
  - b. For vertical installations, cut a hole in the roof large enough to clear the concentric terminal at the location of the terminal (see Section VII - C of this manual for permitted terminal locations).
  - c. If desired, the terminal can be shortened. See Figure 7.32 for specific information on making the terminal kit shorter based on the kit size being used. Cut the pipe squarely and de-burr both the OD and ID of the cut edges.
  - d. Cement the inner pipe section of PVC pipe supplied with this kit to the Wye fitting using a primer and cement listed for use with PVC.
  - e. Cement the outer pipe to the Wye, being careful, to keep the inner and outer pipes concentric.
  - f. Slip the partially assembled terminal through the wall or ceiling from the inside and for horizontal installations orient so that the side outlet on the Wye is on or above the horizontal plane.
  - g. For horizontal installations, seal the gap between the OD of the "outer pipe" and the exterior side of the wall with RTV sealant.



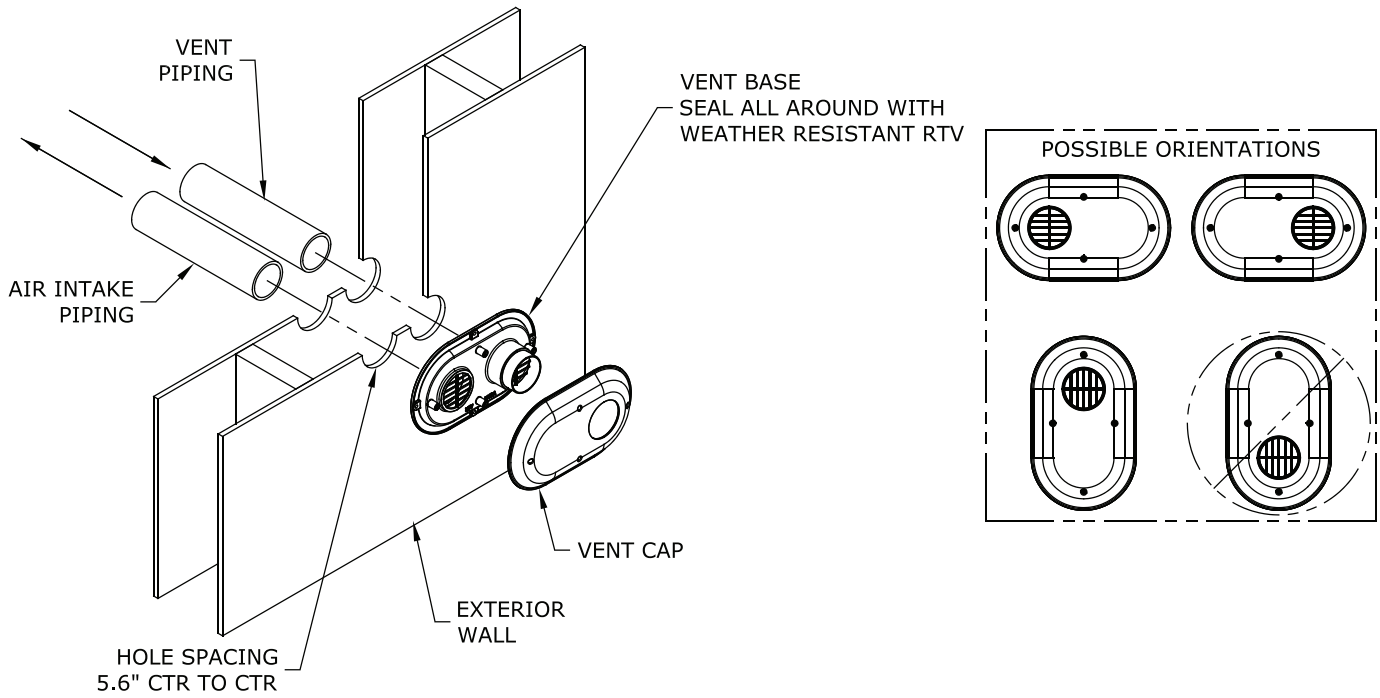
**WARNING** Asphyxiation Hazard. CPVC/PVC vent piping and fittings rely on glued joints for proper sealing. Follow all manufacturer instructions and warnings when preparing pipe ends for joining and using the primer and the cement.

**When PVC is used with the concentric vent kit, a 30" CPVC straight section and elbow must be used prior to connection of the vent system to this terminal. If the vent system is too short to permit this, use an FGV CPVC terminal.**

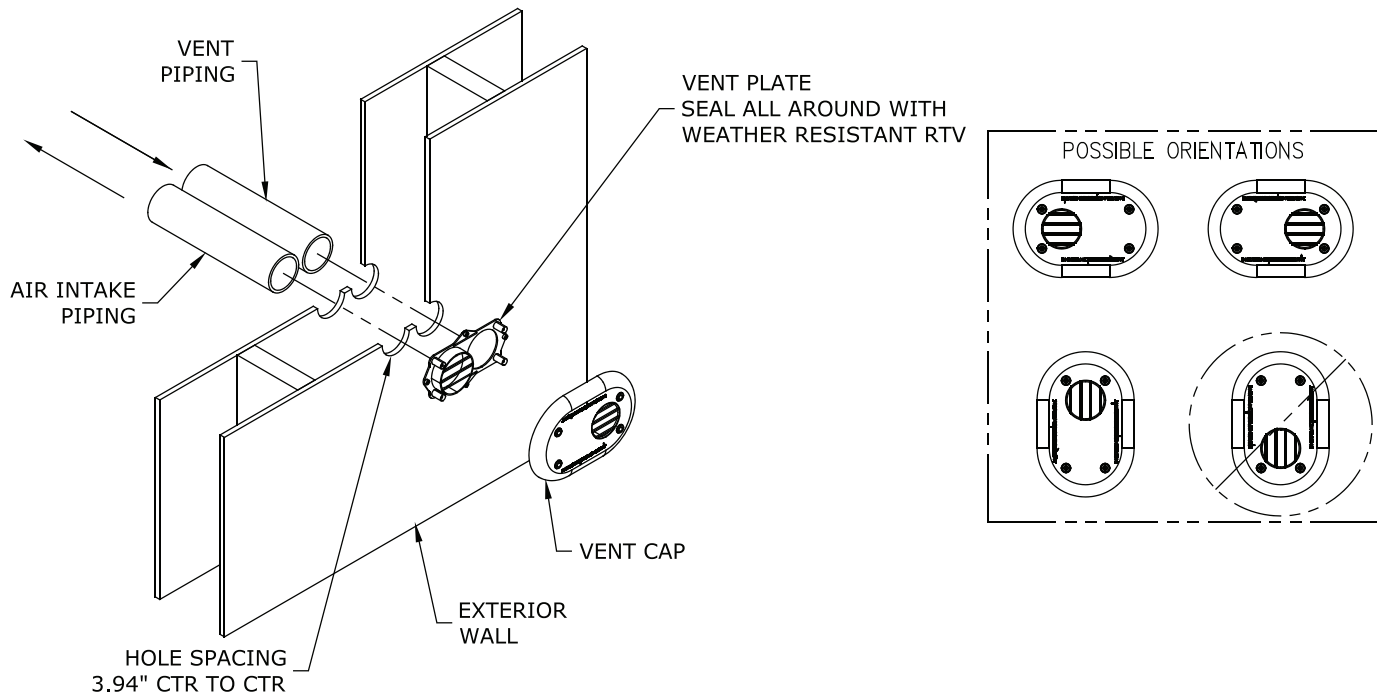
**Do not operate boiler without the rain cap in place.**

**Method of securing and sealing terminals to the outside wall must not restrain the expansion of vent pipe.**

**VII. Venting E. Assembly of CPVC/PVC Vent Systems (continued)**



**Figure 7.30: Installation of IPEX Low Profile Terminal Through Sidewall**



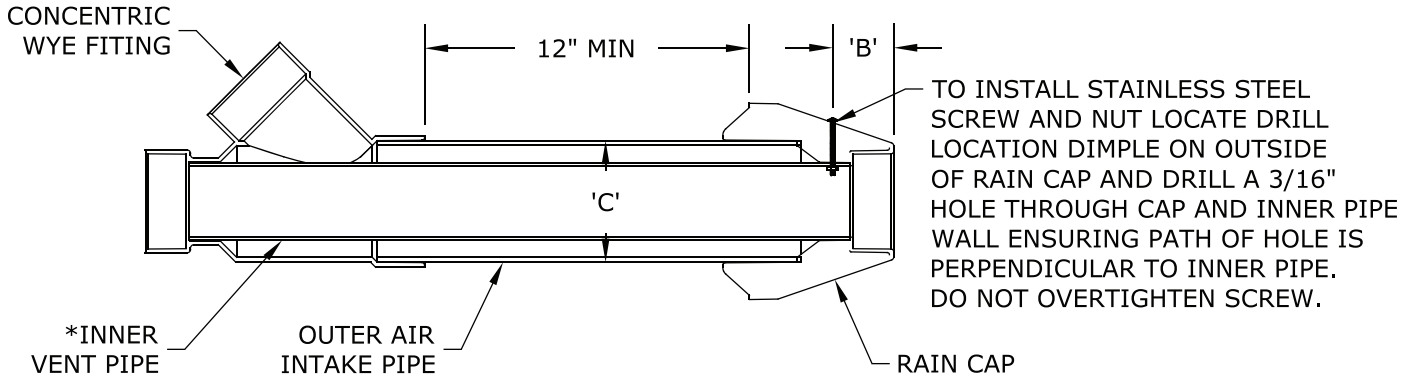
**Figure 7.31: Installation of DiversiTech Low Profile Terminal Through Sidewall**



**VII. Venting E. Assembly of CPVC/PVC Vent Systems (continued)**

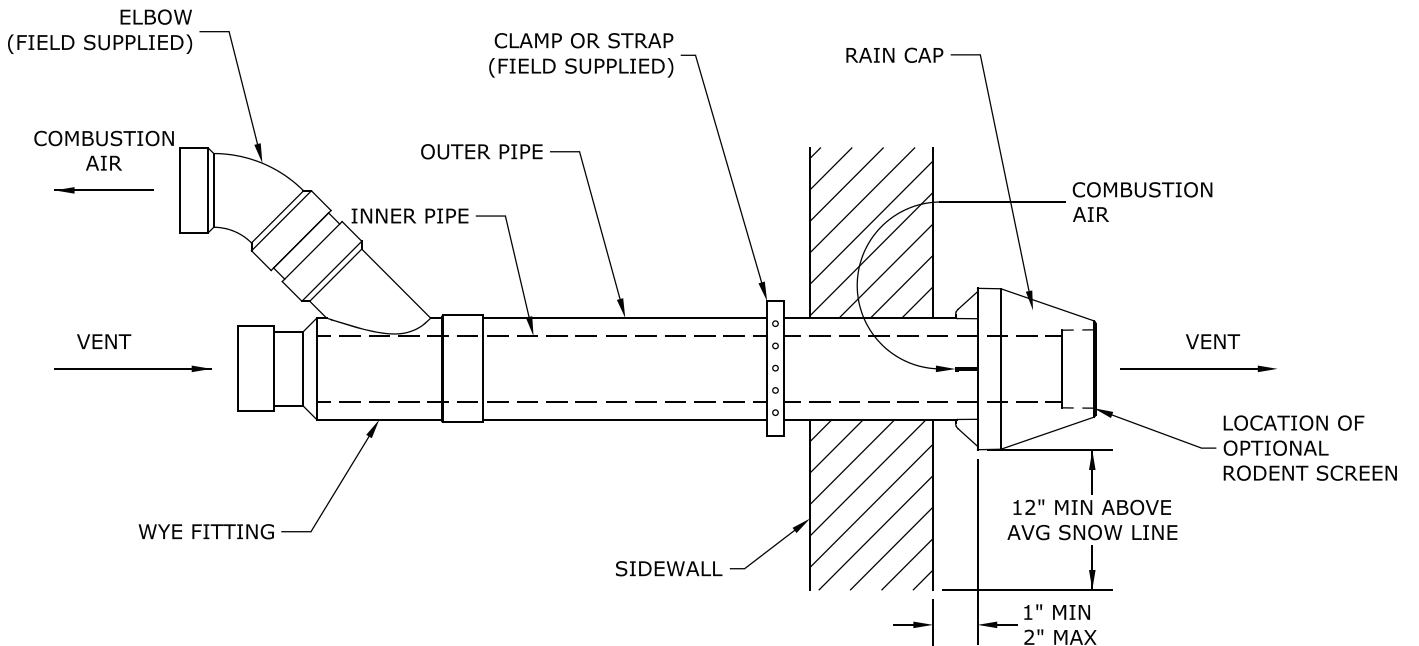
\*OVERALL LENGTH OF INNER PIPE TO BE 'A' INCHES LONGER THAN OVERALL LENGTH OF OUTER PIPE.

KIT SIZE	*'A'	'B'	'C'	MANUFACTURER
3"	8-3/4"	2-1/4"	4-1/2"	IPEX
3"	13-3/16"	1"	4-1/2"	DIVERSITECH



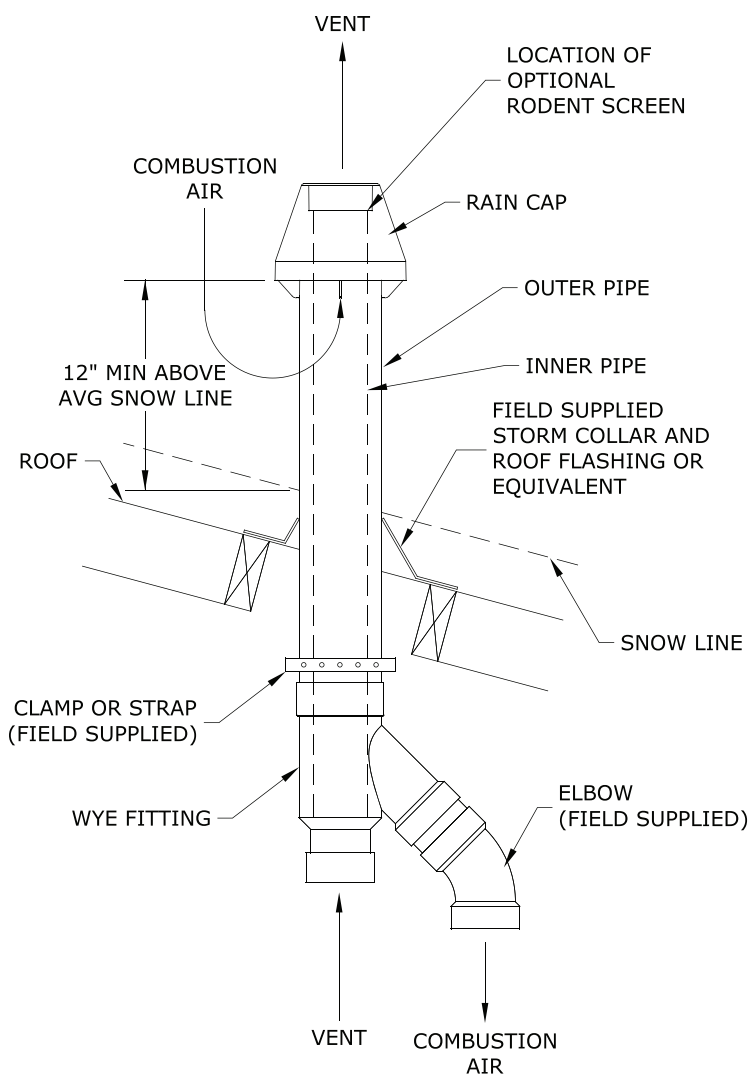
- NOTES: 1. ALL CUTS MUST BE SQUARE AND DEBURRED.  
2. LENGTHENING OF TERMINAL IS NOT PERMITTED.

**Figure 7.32: Cutting IPEX and DiversiTech Concentric Vent Terminals**



**Figure 7.33: Installation of IPEX and DiversiTech Concentric Terminal through Sidewall**

## VII. Venting E. Assembly of CPVC/PVC Vent Systems (continued)



**Figure 7.34: Installation of IPEX and DiversiTech Concentric Terminal Through Roof**

- h. Cement the rain cap onto the inner pipe. If desired, the rain cap can be attached to the inner pipe with the supplied stainless steel screw and nut so that it can be later removed for cleaning and inspection. If this is done, drill a 3/16" clearance hole in the rain cap and inner pipe in the location shown on Figure 7.32 for the size terminal kit being used and affix screw and nut. Do not overtighten. A field supplied rodent screen may also be installed on the end of the rain cap.
- i. For vertical installations, use a roof flashing and storm collar to prevent moisture from entering the building. Seal the roof flashing to the roof using generally accepted practice for the type of roof on the installation. Install the storm collar after verifying that the bottom of the rain cap will be at least 12" above the normal snow line. Apply RTV to seal the storm collars to the terminal.

## VII. Venting F. Assembly of DuraVent PolyPro Vent Systems (continued)

### F. Assembly of DuraVent PolyPro Vent Systems

1. This boiler has been approved for use with the DuraVent PolyPro single wall Polypropylene vent system to be provided by the installer.



**WARNING** Asphyxiation Hazard. Follow these instructions and the installation instructions included by the original Polypropylene venting component manufacturers, M&G/DuraVent. Failure to do so could cause products of combustion to enter the building, resulting in severe property damage, personal injury or death. Where a conflict arises between M&G/DuraVent instructions and these instructions, the more restrictive instructions shall govern.

**Do not mix vent components or joining methods for listed manufacturers.**

**Examine all components for possible shipping damage prior to installation.**

**All condensate that forms in the vent must be able to drain back to the boiler.**

2. Assemble the vent system, starting at the boiler:
  - a. The vent adaptor has three different inside diameters. The middle inside diameter accepts 3" nominal PolyPro (Figure 7.27). A locking band clamp in the adaptor prevents the vent pipe from coming out of the adaptor once it is installed and tightened. Lubricate the upper gasket in the vent adaptor with soapy water and insert the first piece of 3" PolyPro into the adaptor until it bottoms out. Tighten locking band clamp to secure vent pipe.
  - b. Assemble the next piece of 3" PolyPro.
  - c. For each joint, verify that the gasket is evenly seated in the bell (female) end of the pipe. Lubricate this gasket with water. Slide a locking band over the male end of the pipe to be joined as shown in Figure 7.35. Push the male end of the next section of pipe into the bell until it bottoms out, then back out 1/4-5/8" to provide room for thermal expansion. Push barb on locking band over the bell end of the first section of pipe as shown in Figure 7.35.
  - d. Assemble the rest of the vent system per the manufacturer's installation instructions, being sure to pitch horizontal sections back towards the boiler 5/8" per ft.
  - e. Support each horizontal pipe section with a minimum of one wall strap each and at intervals not exceeding 4ft.

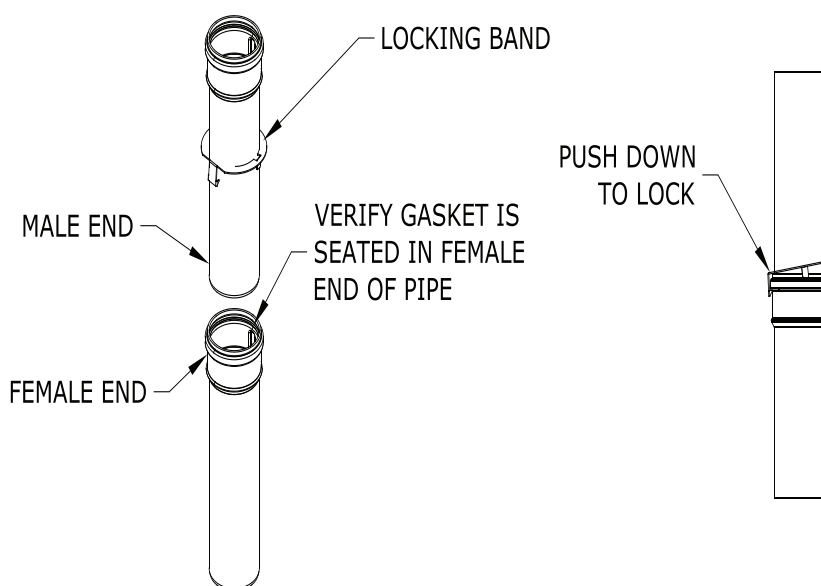


Figure 7.35: PolyPro Locking Band Installation

## VII. Venting F. Assembly of DuraVent PolyPro Vent Systems (continued)

3. Installation of Air Intake System - Start assembly of the PVC air intake system at the boiler. Assembly of the air intake system is done in the same manner as the vent system except as follows:
  - a. Drill a 7/32" clearance hole into the front side of the air intake adapter. Insert the first piece of PVC air intake pipe into the air intake connection and drill a 1/8" tap hole into the PVC which lines up with the 7/32" clearance hole and secure them together with a #10 x 1" sheet metal screw. Seal the joint between the intake pipe and the adaptor with RTV.
  - b. All intake piping may be PVC.
  - c. There is a 0" minimum clearance between the air intake piping and all types of construction.
  - d. To the extent possible, pitch horizontal air intake piping towards the outside.



**WARNING** Asphyxiation Hazard. Vent systems made by M&G/DuraVent rely on gaskets for proper sealing. When these vent systems are used, take the following precautions:

- Make sure that gasket is in position and undamaged in the female end of the pipe.
- Make sure that both the male and female pipes are free of damage prior to assembly.
- Only cut vent pipe as permitted by the vent manufacturer in accordance with their instructions. When pipe is cut, the cut end must be square and carefully de-burred prior to assembly.
- Use locking band clamps at all vent pipe joints.
- Do not use anything other than soapy water to lubricate gaskets.

**NOTICE** The venting system must be free to expand and contract and supported in accordance with the installation instructions included by the original Polypropylene venting component manufacturer, M&G/DuraVent. Polypropylene pipe sections must be disengaged 1/4 to 5/8 in. (6 mm to 16 mm) per joint to allow for thermal expansion.

4. Installation of Horizontal Fitting Terminals (Terminal Option A):
  - a. See Figure 7.36 for proper orientation of twin pipe horizontal terminals. Outer edge of exhaust coupling must be 10" or less from the wall surface. (Figure 7.9)
  - b. Remove the gasket from the end of the integral exhaust coupling and insert DuraVent Bird Guard #3PPS-BG in it's place.
  - c. Add PVC intake per instructions from Section VII - F.
5. Installation of Vertical Fitting Terminals (Terminal Option H):
  - a. See Figure 7.37 for the proper orientation of twin pipe vertical terminals.
  - b. Remove the gasket from the end of the integral exhaust coupling and insert the installer supplied rodent screen in it's place.
  - c. A 180° bend (or two 90° elbows) are installed on the top of the air intake pipe. If two 90° elbows are used, a rodent screen can be installed between them (Figure 7.37). If a 180° bend is used, a the rodent screen in the open side of the bend, using a ring made of PVC pipe. If desired, the termination fittings can be attached to the end of the intake pipes with field supplied stainless steel screws so that they can be later removed for cleaning and inspection. If this is done, drill a clearance hole in these fittings and a tap hole in the end of the intake pipes to accept these screws.
  - d. Use roof flashings and storm collars to prevent moisture from entering the building. Seal the roof flashing to the roof using generally accepted practice for the type of roof on the installation. Apply RTV to seal the storm collars to the vent and intake pipes.

VII. Venting F. Assembly of DuraVent PolyPro Vent Systems (continued)

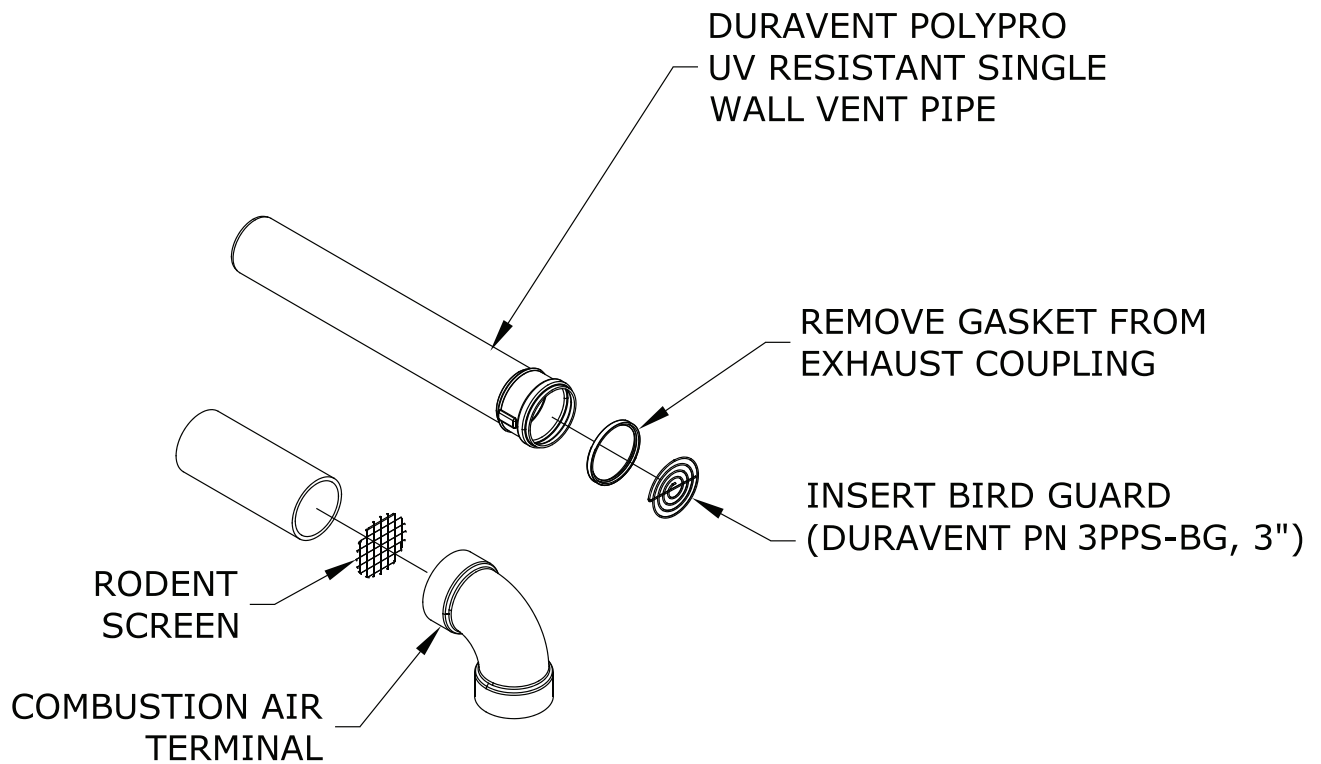


Figure 7.36: Installation of DuraVent PolyPro UV Resistant Single Wall Horizontal Terminal

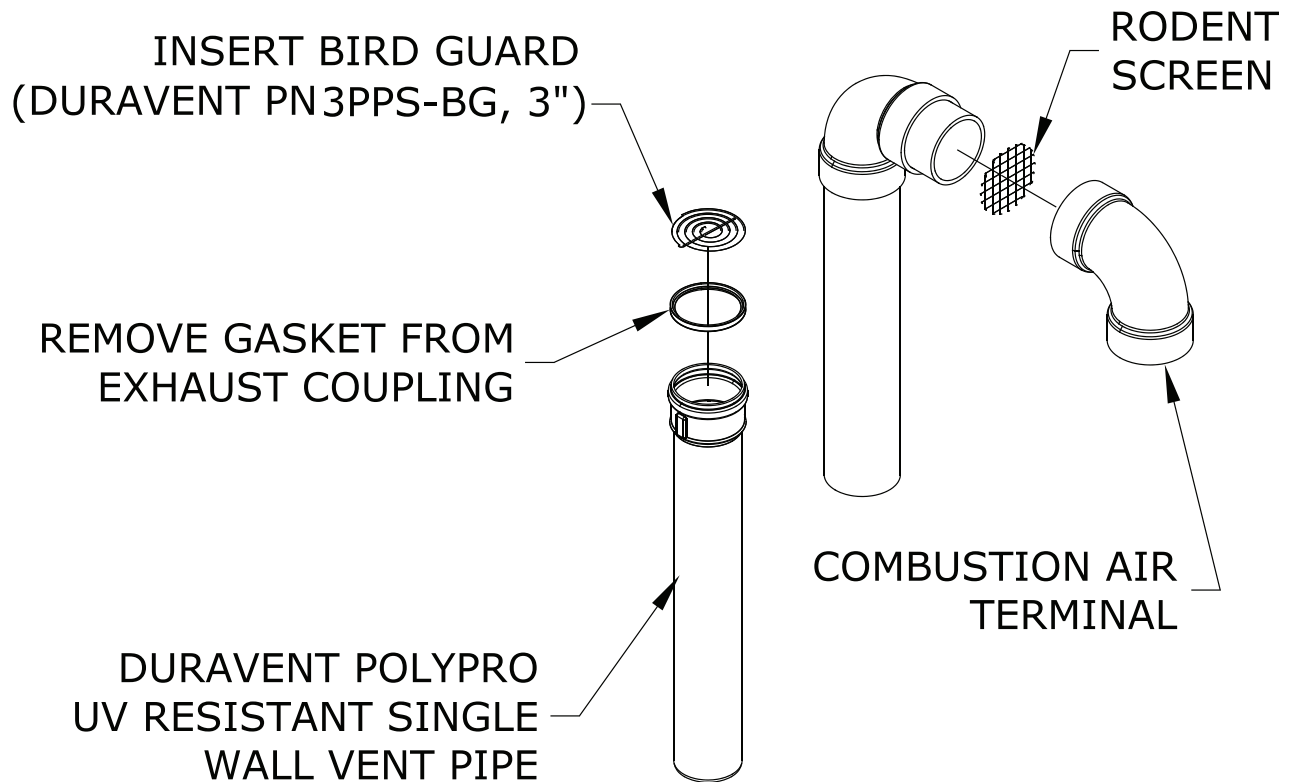
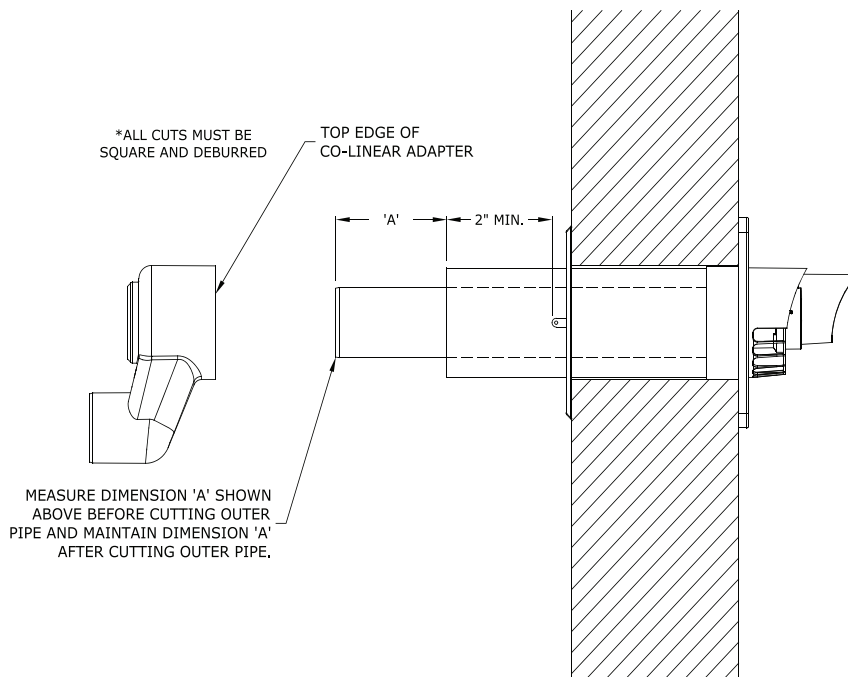


Figure 7.37: Installation of DuraVent PolyPro UV Resistant Single Wall Vertical Terminal

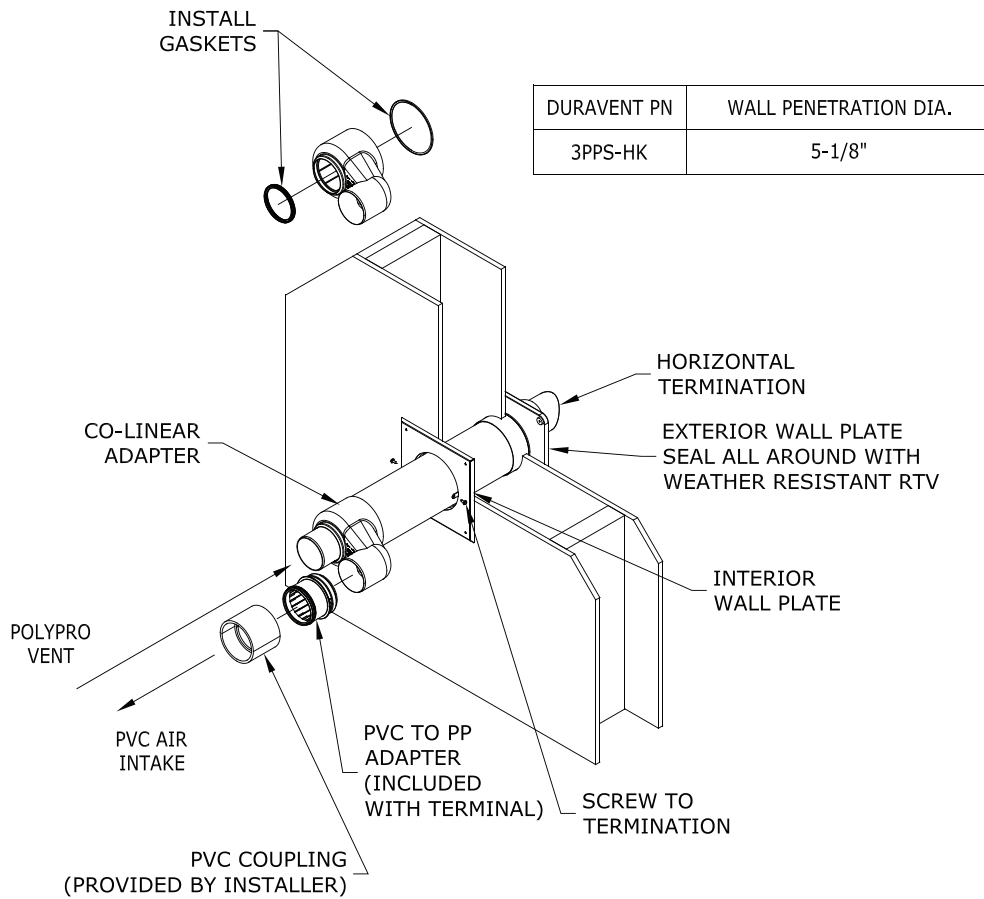
## VII. Venting F. Assembly of DuraVent PolyPro Vent Systems (continued)

6. Installation of DuraVent PolyPro Horizontal Concentric Vent Terminal (Terminal Option D) - Install PolyPro Horizontal Concentric Termination Kit #3PPS-HK (Figure 7.39) as follows:
  - a. At the planned location cut a 5-1/8" round hole for the 3" terminal in the exterior wall. (See Section VII - A of this manual for permitted terminal locations).
  - b. If desired, the terminal can be shortened. Mark the desired location of the cut on the outer pipe no closer than 2" from the edge of the tab on the interior wall plate. Prior to cutting outer pipe measure dimension 'A' of the inner pipe as shown in Figure 7.38 and maintain this dimension after cutting the outer pipe. All cuts must be square and de-burred.
  - c. Attach the exterior wall plate and seal all around with weather resistant RTV.
  - d. Slide the cap through the exterior wall plate and hole from the outside of the building and orient the termination so the air intake slots face down. The cap must be installed level or sloped 1/8" per foot away from the appliance.
  - e. Seal the termination to the exterior wall plate with weather resistant RTV.
  - f. Slide the interior wall plate over the termination and attach to the wall from inside the room.
  - g. Attach the interior wall plate to the termination with the provided hardware.
  - h. Install gaskets into co-linear adapter.
  - i. Attach co-linear adapter to horizontal termination and orient so that the side outlet on the adapter is on or above the horizontal plane.
7. Vertical Installations using PolyPro Vertical Concentric Termination Kit #3PPS-VK (Figure 7.40):
  - a. Cut a hole in the roof large enough to clear the concentric terminal at the location of the terminal (see Section VII - A of this manual for permitted terminal locations).
  - b. Use a roof flashing and storm collar to prevent moisture from entering the building. See Figure 7.40 for the model number of the flashing to be used depending on the type of roof. Seal the roof flashing to the roof using generally accepted practice for the type of roof on the installation.
  - c. Slide the vertical termination into the flashing from above until seated on the flashing.
  - d. Plumb the termination and mount the support bracket to the structure.
  - e. Install gaskets into co-linear adapter.
  - f. Attach co-linear adapter to vertical termination.

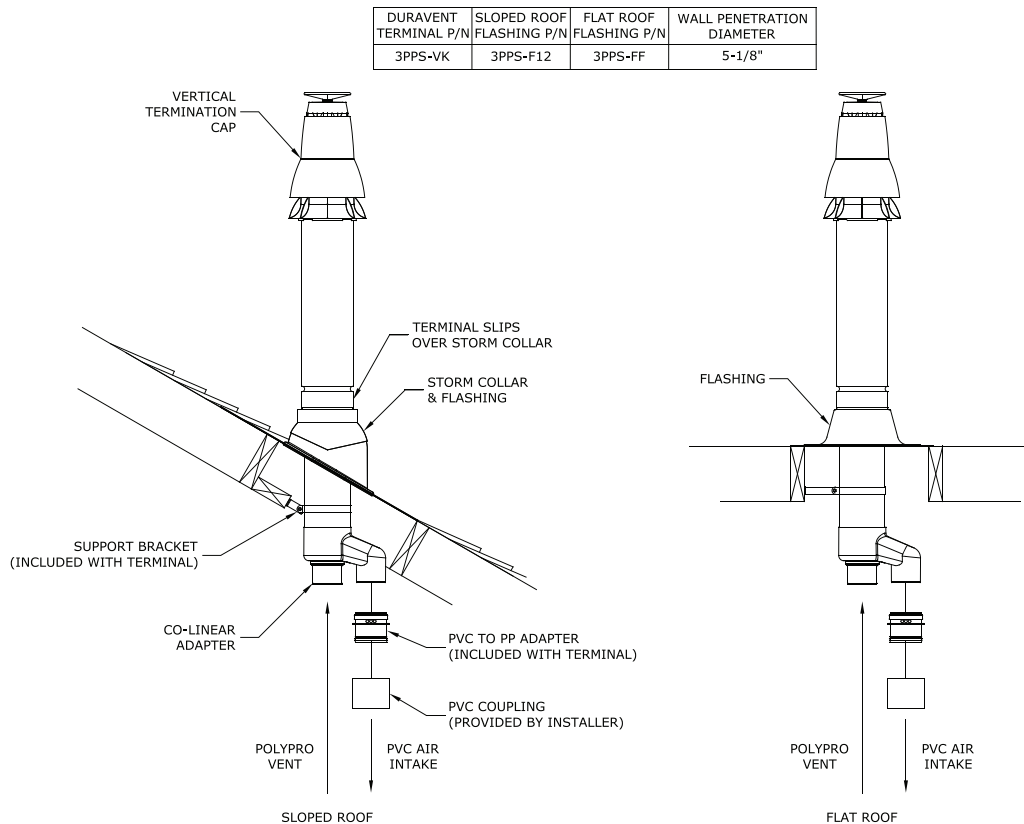


**Figure 7.38: Cutting DuraVent PolyPro Horizontal Concentric Vent Terminal**

## VII. Venting F. Assembly of DuraVent PolyPro Vent Systems (continued)



**Figure 7.39: Installation of DuraVent PolyPro Concentric Vent Terminal Through Sidewall**



**Figure 7.40: Installation of DuraVent PolyPro Concentric Terminal Through Roof**

## VII. Venting F. Assy of DuraVent PolyPro & G. Selkirk Polyflue Vent Systems (continued)

### 8. Installations using PolyPro-flex (Vent Options 9 & 15):



#### **WARNING**

**Asphyxiation Hazard. When using PolyPro flex, observe the following precautions:**

- **PolyPro flex may be damaged by handling at low temperatures. Do not bend, uncoil, or attempt to install if it has been stored at a temperature below 42°F without allowing it to warm to a higher temperature first.**
- **Do not bend PolyPro flex more than 45°.**
- **Instructions below reference the DuraVent PolyPro Flex instruction manual. Not all vent configurations shown in the DuraVent manual are approved for use with this boiler.**

Refer to DuraVent PolyPro flex Instructions for assembly of all flex components including the chimney cap and the adaptor to rigid PolyPro at the base of the masonry or B vent chimney. In addition, observe the following requirements:

- a. Refer to the appropriate Vent option in Tables 7.13b or 7.21 for a list of the principle flex components required. Rigid vent pipe by the same manufacturer will also be required for the run from the boiler to the base of chimney.
- b. Masonry chimneys cannot be used for an air chase
- c. B vent chimneys can only be used for an air chase (Vent option 9) if the B vent has the minimum size shown in Table 7.13b and is fully accessible for sealing of all joints and seams.
- d. When Vent Option 9 is used, install a Tee on the base of the B-vent that is the same size as the B- Vent chimney. Install the PolyPro Lower B-Vent adaptor in the base of this Tee as described in the DuraVent PolyPro Flex instructions.

Connection of the PVC air intake pipe to the side outlet of the tee is made using a cap and a PVC socket x male thread adaptor. Cut a clearance hole in the cap for the male threads. Secure the adaptor to the cap using a 3" electrical conduit lock nut. Seal all joints with RTV.

### **G. Assembly of Selkirk Polyflue Vent Systems**

1. This boiler has been approved for use with the Selkirk Polyflue single wall Polypropylene vent system to be provided by the installer.
2. Assemble the vent system, starting at the boiler:
  - a. The vent adaptor has three different inside diameters. The middle inside diameter accepts 3" nominal Polyflue (Figure 7.27). A locking band clamp in the adaptor prevents the vent pipe from coming out of the adaptor once it is installed and tightened. Lubricate the gaskets in the vent adaptor with mild soapy water and insert the first piece of 3" Polyflue into the adaptor until it bottoms out. Tighten locking band clamp to secure vent pipe.
  - b. Assemble the next piece of 3" Polyflue.
  - c. For each joint, verify that the gasket is evenly seated in the bell (female) end of the pipe. Lubricate this gasket with mild soapy water. Slide a Pipe Locking Band over the male end of the pipe to be joined as shown in Figure 7.41. Push the male end of the next section of pipe into the bell until it bottoms out, then back out 1/8—1/4" to provide room for thermal expansion. Slide pipe locking band over the female end of the connections and tighten both hose clamps.
  - d. Assemble the rest of the vent system per the manufacturer's installation instructions, being sure to pitch horizontal sections back towards the boiler 5/8" per ft.



## VII. Venting G. Assembly of Selkirk Polyflue Vent Systems (continued)

3. Installation of Air Intake System - Start assembly of the PVC air intake system at the boiler. Assembly of the air intake system is done in the same manner as the vent system except as follows:
  - a. Drill a 7/32" clearance hole into the front side of the air intake adapter. Insert the first piece of PVC air intake pipe into the air intake connection and drill a 1/8" tap hole into the PVC which lines up with the 7/32" clearance hole and secure them together with a #10 x 1" sheet metal screw. Seal the joint between the intake pipe and the adaptor with RTV.
  - b. All intake piping may be PVC. There is a 0" minimum clearance between the air intake piping and all types of construction.
  - c. To the extent possible, pitch horizontal air intake piping towards the outside.
4. Installation of Horizontal Fitting Terminals (Terminal Option A):
  - a. See Figure 7.42 for proper orientation of twin pipe horizontal terminals. Outer edge of exhaust coupling must be 10" or less from the wall surface. (Figure 7.9)
  - b. Remove the gasket from the end of the integral exhaust coupling and insert Selkirk #3PFHVST in its place.
  - c. Add PVC intake per instructions from Section VII - F.
5. Installation of Vertical Fitting Terminals (Terminal Option H):
  - a. See Figure 7.43 for the proper orientation of twin pipe vertical terminals.
  - b. Remove the gasket from the end of the integral exhaust coupling and insert Selkirk #3PFHVST in its place.
  - c. A 180° bend (or two 90° elbows) are installed on the top of the air intake pipe. If two 90° elbows are used, a rodent screen can be installed between them (Figure 7.43). If a 180° bend is used, install a rodent screen in the open side of the bend, using a ring made of PVC pipe. If desired, the termination fittings can be attached to the end of the intake pipes with field supplied stainless steel screws so that they can be later removed for cleaning and inspection. If this is done, drill a clearance hole in these fittings and a tap hole in the end of the intake pipes to accept these screws.
  - d. Use roof flashings and storm collars to prevent moisture from entering the building. Seal the roof flashing to the roof using generally accepted practice for the type of roof on the installation. Apply RTV to seal the storm collars to the vent and intake pipes.



**Asphyxiation Hazard. Selkirk Polyflue vent systems rely on gaskets for proper sealing. When this vent system is used, take the following precautions:**

- **Make sure that gasket is in position and undamaged in the female end of the pipe.**
- **Make sure that both the male and female pipes are free of damage prior to assembly.**
- **Only cut vent pipe as permitted by the vent manufacturer in accordance with their Instructions. When pipe is cut, the cut end must be square and carefully de-burred prior to assembly.**
- **Use pipe locking bands at all vent pipe joints.**

**NOTICE** The venting system must be free to expand and contract and supported in accordance with the installation instructions included by the original Polypropylene venting component manufacturer, Selkirk. Polypropylene pipe sections must be disengaged 1/8 to 1/4 in. (3mm to 6mm) per joint to allow for thermal expansion.

## VII. Venting G. Assembly of Selkirk Polyflue Vent Systems (continued)

### 6. Installations using flexible Polyflue (Vent Option 16):



#### WARNING

Asphyxiation Hazard. When using Polyflue flex, observe the following precautions:

- Polyflue flex may be damaged by handling at low temperatures. Do not bend, uncoil or attempt to install if it has been stored at a temperature below 42°F without allowing it to warm to a higher temperature first.
- Do not bend Polyflue flex more than 45°.
- Instructions below reference the Selkirk Polyflue instruction manual. Not all vent configurations shown in the Selkirk vent manual are approved for use with this boiler.

Refer to Selkirk Polyflue Instructions for assembly of all flex components including the chimney cap and the adaptor to rigid Polyflue at the base of the masonry or B vent chimney. In addition, observe the following requirements:

- a. Refer to the appropriate Vent option in Table 7.21 for a list of the principle flex components required. Rigid vent pipe by the same manufacturer will also be required for the run from the boiler to the base of the chimney.
- b. Polyflue may not be used in air chase applications.

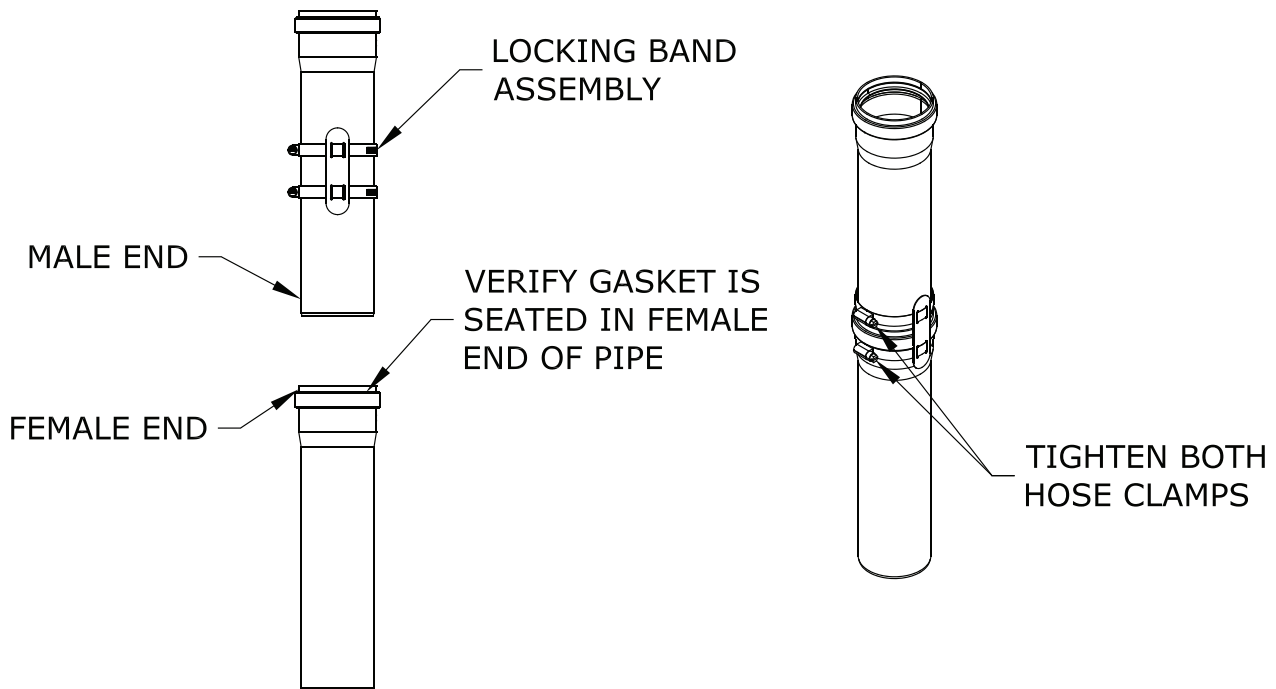


Figure 7.41: Polyflue Pipe Locking Band Installation

VII. Venting G. Assembly of Selkirk Polyflue Vent Systems (continued)

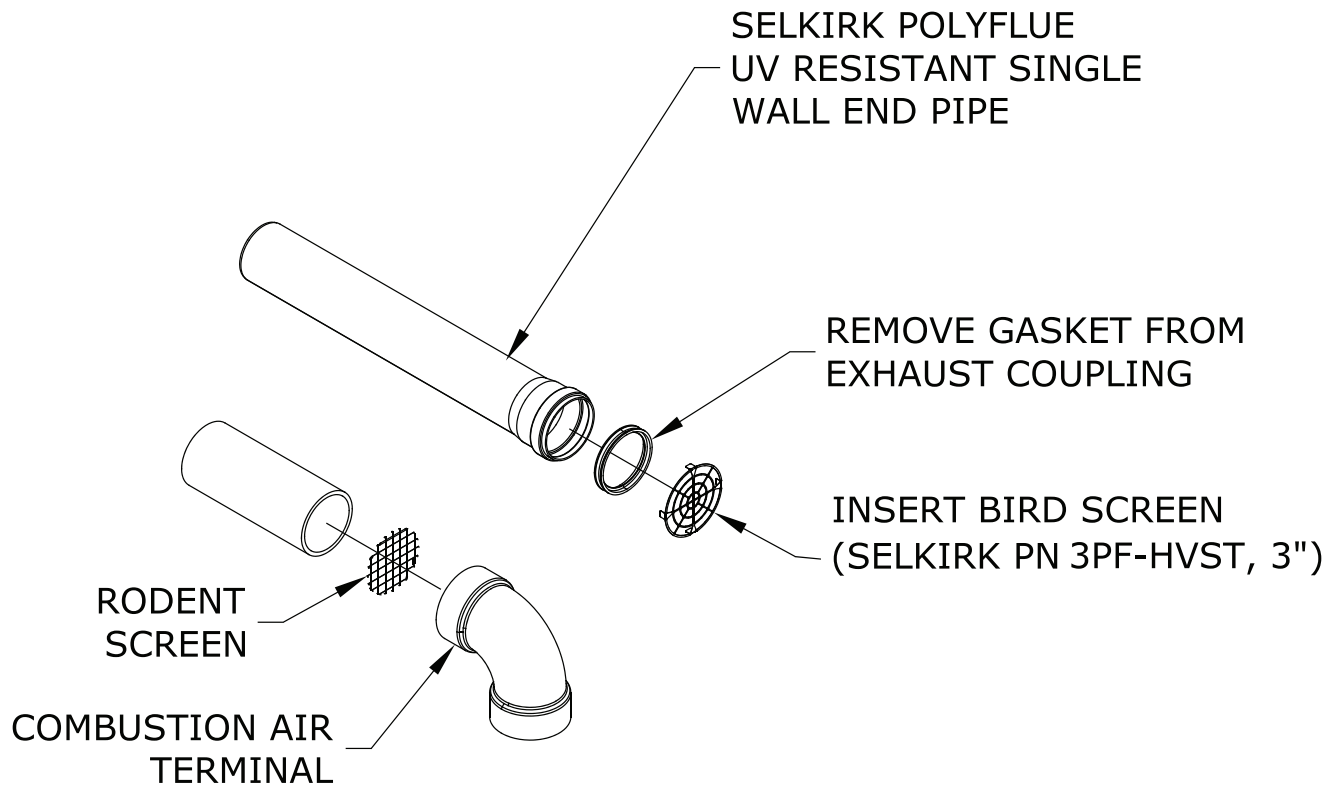


Figure 7.42: Installation of Selkirk Polyflue UV Resistant Single Wall Horizontal Terminal

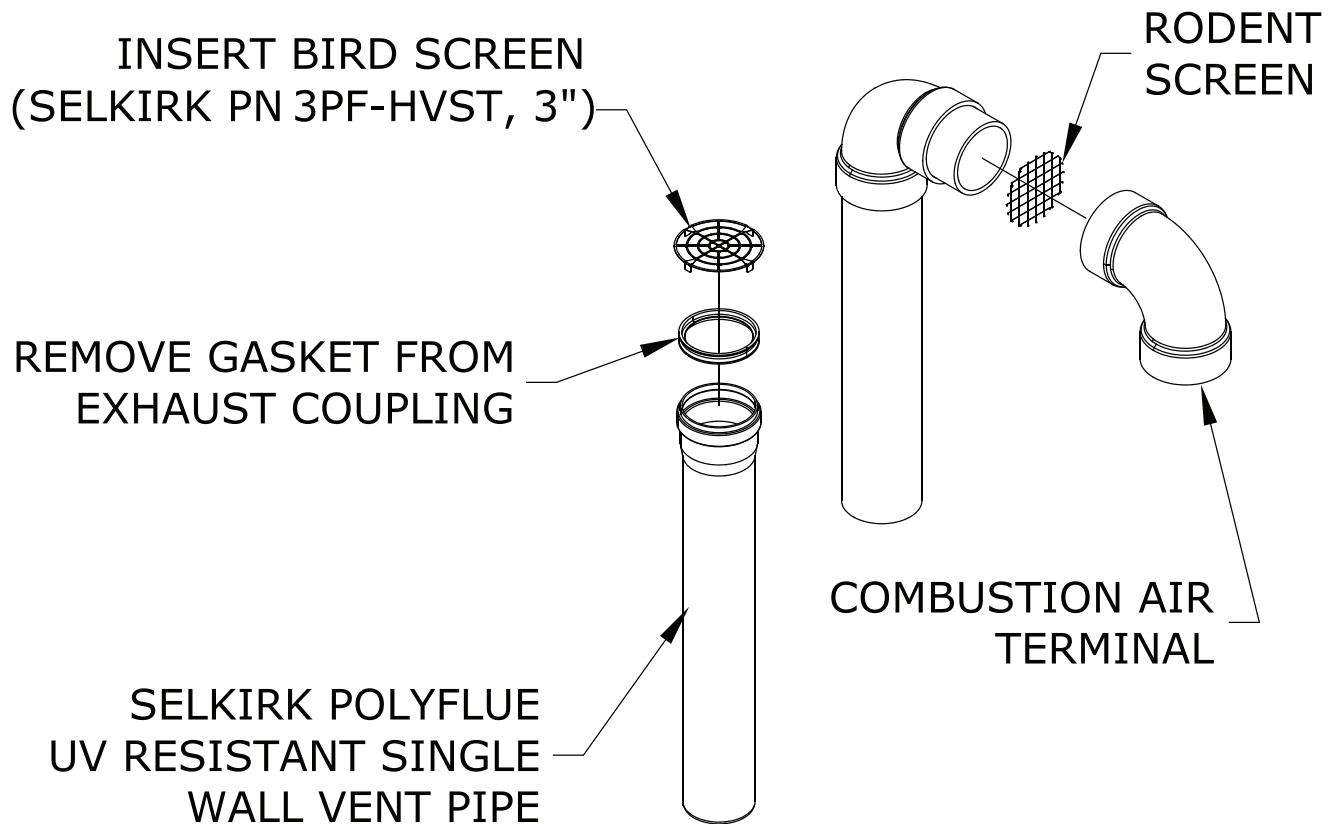


Figure 7.43: Installation of Selkirk Polyflue UV Resistant Single Wall Vertical Terminal

## VII. Venting H. Assembly of Centrotherm InnoFlue Vent Systems

### H. Assembly of Centrotherm InnoFlue Vent Systems

1. This boiler has been approved for use with the Centrotherm InnoFlue single wall Polypropylene vent system to be provided by the installer.



**WARNING** Asphyxiation Hazard. Follow these instructions and the installation instructions included by the original Polypropylene venting component manufacturers, Centrotherm. Failure to do so could cause products of combustion to enter the building, resulting in severe property damage, personal injury or death. Where a conflict arises between Centrotherm instructions and these instructions, the more restrictive instructions shall govern.

**Do not mix vent components or joining methods for listed manufacturers.**

**Examine all components for possible shipping damage prior to installation.**

**All condensate that forms in the vent must be able to drain back to the boiler.**

2. Assemble the vent system, starting at the boiler:
  - a. The vent adaptor has three different inside diameters. The middle inside diameter accepts 3" nominal InnoFlue (Figure 7.27). A locking band clamp in the adaptor prevents the vent pipe from coming out of the adaptor once it is installed and tightened. Lubricate the upper gasket in the vent adaptor with water and insert the first piece of 3" InnoFlue into the adaptor until it bottoms out. Tighten locking band clamp to secure vent pipe.
  - b. Assemble the next piece of 3" InnoFlue.
  - c. For each joint, verify that the gasket is evenly seated in the bell (female) end of the pipe. Lubricate this gasket with Centrocerin # IACE50. Slide a connector ring over the male end of the pipe to be joined as shown in Figure 7.44. Push the male end of the next section of pipe into the bell until it bottoms out, then back out 1/4" to provide room for thermal expansion. Push hook on connecting ring over the bell end of the first section of pipe as shown in Figure 7.44.
  - d. Assemble the rest of the vent system per the manufacturer's installation instructions, being sure to pitch horizontal sections back towards the boiler 5/8"/ft.
  - e. Support each horizontal pipe section with a minimum of one wall strap each and at intervals not exceeding 39in.

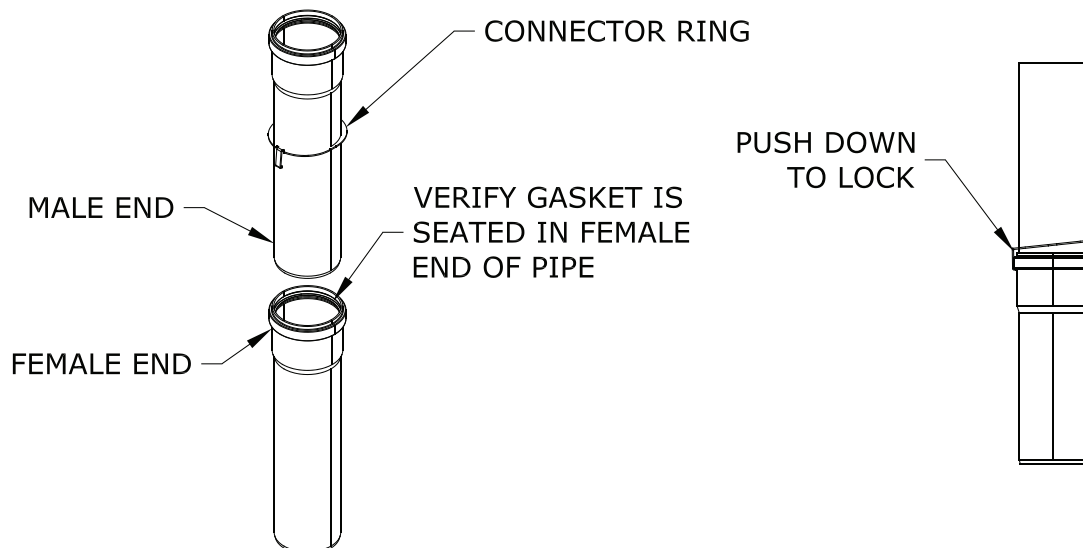


Figure 7.44: InnoFlue Connector Ring Installation

## VII. Venting H. Assembly of Centrotherm InnoFlue Vent Systems

3. Installation of Air Intake System - Start assembly of the PVC air intake system at the boiler. Assembly of the air intake system is done in the same manner as the vent system except as follows:
  - a. Drill a 7/32" clearance hole into the front side of the air intake adapter. Insert the first piece of PVC air intake pipe into the air intake connection and drill a 1/8" tap hole into the PVC which lines up with the 7/32" clearance hole and secure them together with a #10 x 1" sheet metal screw. Seal the joint between the intake pipe and the adaptor with RTV.
  - b. All intake piping may be PVC.
  - c. There is a 0" minimum clearance between the air intake piping and all types of construction.
  - d. To the extent possible, pitch horizontal air intake piping towards the outside.



**Asphyxiation Hazard. Vent systems made by Centrotherm rely on gaskets for proper sealing. When this vent system is used, take the following precautions:**

- **Make sure that gasket is in position and undamaged in the female end of the pipe.**
- **Make sure that both the male and female pipes are free of damage prior to assembly.**
- **Only cut vent pipe as permitted by the vent manufacturer in accordance with their instructions. When pipe is cut, the cut end must be square and carefully de-burred prior to assembly.**
- **Use connector rings at all vent pipe joints.**

**NOTICE** The venting system must be free to expand and contract and supported in accordance with the installation instructions included by the original Polypropylene venting component manufacturer, Centrotherm. Polypropylene pipe sections must be disengaged 1/4 in. (6mm) per joint to allow for thermal expansion.

4. Installation of Horizontal Fitting Terminals (Terminal Option A):
  - a. See Figure 7.45 for proper orientation of twin pipe horizontal terminals. Outer edge of end pipe must be 10" or less from the wall surface. (Figure 7.5)
  - b. Use plain end UV stabilized Centrotherm 3" pipe # ISEP03 or ISEP0339 and insert Centrotherm Bird Screen #IASPP03 in the end of the pipe.
  - c. Add PVC intake per instructions from Section VII - F.
5. Installation of Vertical Fitting Terminals (Terminal Option H):
  - a. See Figure 7.46 for the proper orientation of twin pipe vertical terminals.
  - b. Use plain end UV stabilized Centrotherm 3" pipe # ISEP03 or ISEP0339 and insert Centrotherm Bird Screen #IASPP03 in the end of the pipe.
  - c. A 180° bend (or two 90° elbows) are installed on the top of the air intake pipe. If two 90° elbows are used, a rodent screen can be installed between them (Figure 7.46). If a 180° bend is used, install a rodent screen in the open side of the bend, using a ring made of PVC pipe. If desired, the termination fittings can be attached to the end of the intake pipes with field supplied stainless steel screws so that they can be later removed for cleaning and inspection. If this is done, drill a clearance hole in these fittings and a tap hole in the end of the intake pipes to accept these screws.
  - d. Use roof flashings and storm collars to prevent moisture from entering the building. Seal the roof flashing to the roof using generally accepted practice for the type of roof on the installation. Apply RTV to seal the storm collars to the vent and intake pipes.

VII. Venting H. Assembly of Centrotherm InnoFlue Vent Systems

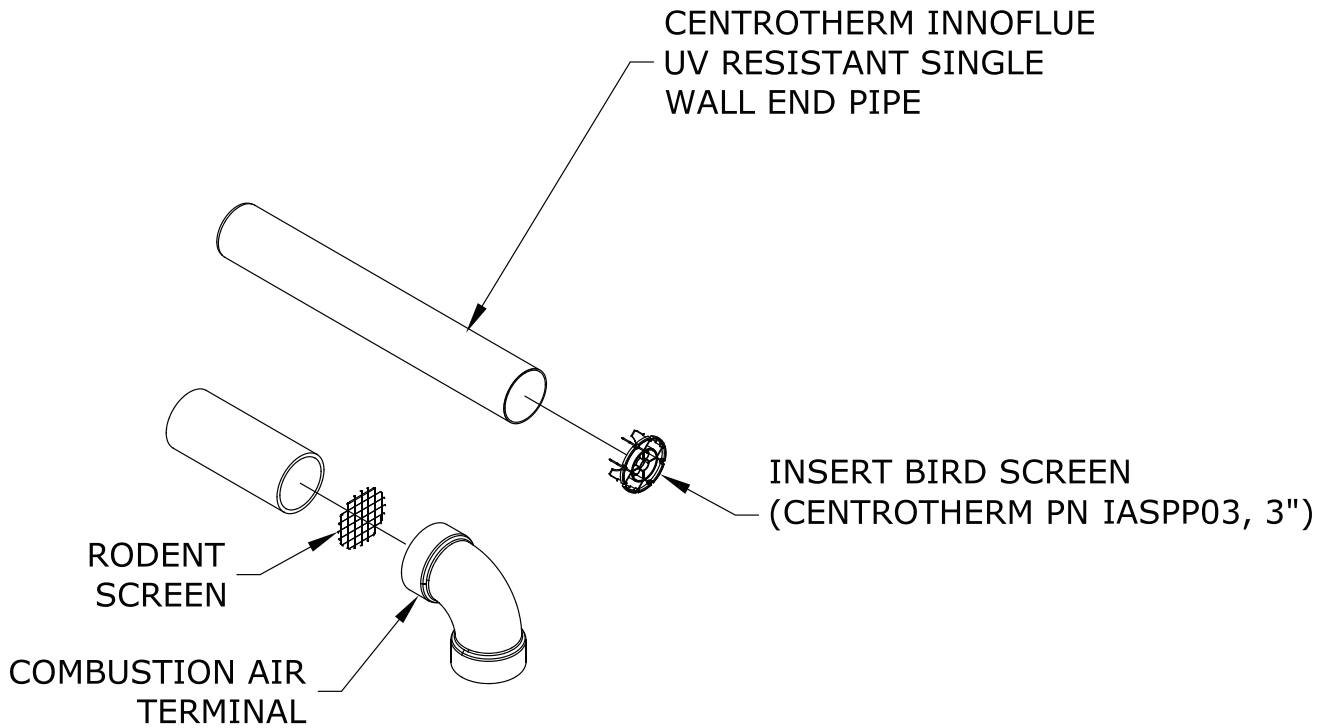


Figure 7.45: Installation of Centrotherm InnoFlue UV Stabilized Single Wall Horizontal Terminal

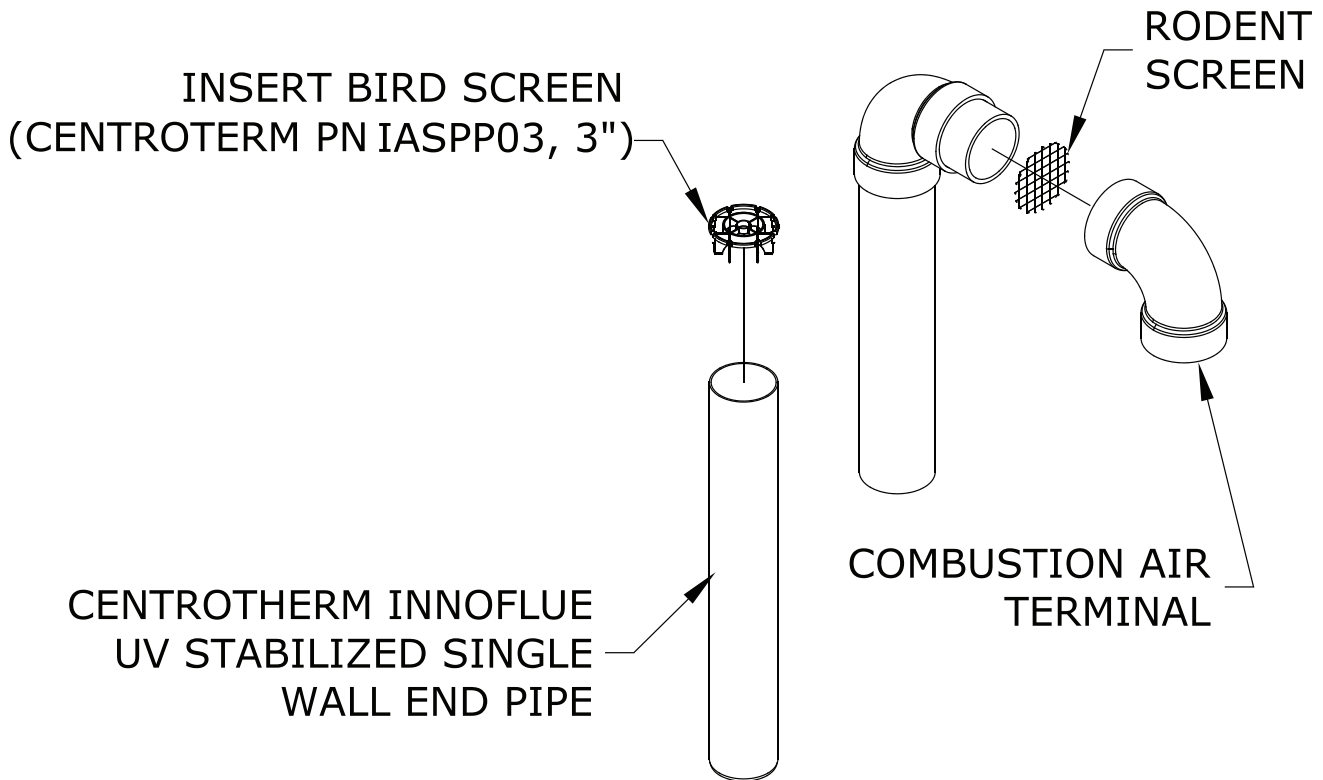


Figure 7.46: Installation of Centrotherm InnoFlue UV Stabilized Single Wall Vertical Terminal

## VII. Venting H. Assembly of Centrotherm InnoFlue Vent Systems

### 6. Installations using InnoFlue Flex (Vent Options 10 & 17):



#### **WARNING**

**Asphyxiation Hazard. When using InnoFlue Flex, observe the following precautions:**

- **InnoFlue Flex may be damaged by handling at low temperatures. Do not bend, uncoil or attempt to install if it has been stored at a temperature below 42°F without allowing it to warm to a higher temperature first.**
- **Do not bend InnoFlue Flex more than 45°.**
- **Instructions below reference the Centrotherm InnoFlue instruction manual. Not all vent configurations shown in the Centrotherm manual are approved for use with this boiler.**

Refer to Centrotherm InnoFlue Instructions for assembly of all flex components including the chimney cap and the adaptor to rigid InnoFlue at the base of the masonry or B vent chimney. In addition, observe the following requirements:

- a. Refer to the appropriate Vent option in Tables 7.13b or 7.21 for a list of the principle flex components required. Rigid vent pipe by the same manufacturer will also be required for the run from the boiler to the base of chimney.
- b. Masonry chimneys cannot be used for an air chase
- c. B vent chimneys can only be used for an air chase (Vent option 10) if the B vent has the minimum size shown in Table 7.13b and is fully accessible for sealing of all joints and seams.
- d. When Vent Option 10 is used, install a Tee of the same size at the base of the vent. Route the smooth section of InnoFlue Flex (3") through a cap in the base of this Tee. Use a Centrotherm IAWP03B wall plate and RTV to seal this penetration. Install the Base Support using the Base support bracket as described in the InnoFlue installation manual.

Connection of the PVC air intake pipe to the side outlet of the tee is made using a cap and a PVC socket x male thread adaptor. Cut a clearance hole in the cap for the male threads. Secure the adaptor to the cap using a 3" electrical conduit lock nut. Seal all joints with RTV.

## VII. Venting I. Assembly of Stainless Steel Vent Systems

### I. Assembly of Stainless Steel Vent Systems

1. This boiler has been approved for use with DuraVent FasNSeal Flex Stainless Steel vent systems to be provided by the installer.



**Asphyxiation Hazard. Follow these instructions and the installation instructions included by the original stainless steel venting component manufacturer, DuraVent. Failure to do so could cause products of combustion to enter the building, resulting in severe property damage, personal injury or death. Where a conflict arises between DuraVent instructions and these instructions, the more restrictive instructions shall govern.**

**Do not mix vent components from listed manufacturers.**

**Examine all components from listed manufacturers.**

**All condensate that forms in the vent must be able to drain back to the boiler.**

2. The vent adaptor has three different inside diameters. The smaller, lower diameter accepts 3" Stainless steel (Figure 7.27). A locking band clamp in the adaptor prevents the vent pipe from coming out of the adaptor once it is installed and tightened. Lubricate the upper gaskets in the vent adaptor with water and insert the first piece of 3" stainless into the adaptor until it bottoms out. Tighten locking band clamp to secure vent pipe.
3. Installation of Air Intake System - Start assembly of the PVC air intake system at the boiler. Assembly of the air intake system is done in the same manner as the vent system except as follows:
  - a. Drill a 7/32" clearance hole into the front side of the air intake adaptor. Insert the first piece of PVC air intake pipe into the air intake connection and drill a 1/8" tap hole into the PVC which lines up with the 7/32" clearance hole and secure them together with a #10 x 1" sheet metal screw. Seal the joint between the intake pipe and the adaptor with RTV.
  - b. All intake piping may be PVC.
  - c. There is a 0" minimum clearance between the air intake piping and all types of construction.
  - d. To the extent possible, pitch horizontal air intake piping towards the outside.



**Asphyxiation Hazard. Vent systems made by DuraVent rely on gaskets for proper sealing. When these vents systems are used, take the following precautions:**

- **Make sure that gasket is in position and undamaged in the female end of the pipe**
- **Make sure that both male and female pipes are free of damage prior to assembly.**
- **Only cut vent pipe as permitted by the vent manufacturer in accordance with their instructions.**

**When pipe is cut, the cut end must be square and carefully de-burred prior to assembly.**

4. Installation using DuraVent FasNSeal Flex (Vent Option 18)  
Refer to manufacturer's instructions for assembly of all flex components including the chimney cap and adaptor to rigid pipe at base of masonry or B Vent Chimney (DuraVent FasNSeal Flex only permitted in masonry type chimneys). In addition, observe the following requirements:
  - a. Refer to the appropriate Vent option in table 7.21 for a list of the principle flex components required. Rigid vent pipe by the same manufacturer will also be required for the run from the boiler to the base of chimney.
  - b. Masonry chimneys cannot be used for an air chase.
  - c. Flexible stainless steel vent shall be installed in an UNUSED masonry chimney/chase and supplying combustion air through a separate wall or roof combustion air terminal. The unused chimney flue must be structurally sound and in good repair. A chimney is considered UNUSED when it is not being used for any appliance venting. If chimney is a multiple flue type where one of the multiple flues is being used for an appliance venting, the flexible stainless vent installation is permitted through an adjacent, unused flue providing a local authority having jurisdiction approves such installation. (Figure 7.25b)



## VII. Venting I. Assembly of Stainless Steel Vent Systems (continued)

- d. When flexible stainless steel pipe is used for combustion product venting, it must be installed at vertical or near vertical orientation. This will insure proper condensate flow back towards the boiler.
- e. Follow flexible stainless steel pipe manufacturer specific instructions regarding application/listing, permits, minimum clearances to combustibles, installation details (proper joint assembly, pipe support and routing, gasket and fitting installation, optional tooling availability/usage, routing through masonry combination of combustion product venting and combustion air supply).
- f. When there is a conflict between flexible stainless steel pipe manufacturer installation instructions and boiler installation, Operating and Service Instructions, the more restrictive instructions shall govern.



**WARNING** Asphyxiation Hazard. Flexible stainless steel vent must be installed only in an UNUSED chimney flue. A chimney flue is considered UNUSED when it is not being used for any appliance venting. If chimney is a multiple flue type where one of the multiple flue is being used for an appliance venting, the flexible stainless vent installation is permitted through an adjacent, unused flue providing a local authority having jurisdiction approves such installation.

**Asphyxiation Hazard.** Flexible stainless steel pipe must be installed at vertical or near vertical plane when used for combustion product venting. Failure to do so will result in improper condensate drainage towards the boiler and possible subsequent vent pipe blockage.

## VII. Venting J. Condensate Trap and Drain Line (continued)

### J. Condensate Trap and Drain Line

All condensate which forms in the boiler or vent system passes through the heat exchanger and out of a bottom drain port which is connected to the condensate trap with a hose. This trap allows condensate to drain from the heat exchanger while retaining flue gases in the boiler. This trap is an integral part of the boiler but must be connected to a drain pipe as shown in Figure 7.47. A length of corrugated tubing is supplied with the boiler and is connected to the trap as shown in Figure 7.47. Note the following when disposing of the condensate:

1. If the corrugated condensate drain line must be extended, construct the extension from PVC or CPVC pipe. Insert the hose provided with the boiler into the end of the extension as shown in Figure 7.47.
2. Condensate is slightly acidic. Do not use metallic pipe or fittings in the condensate drain line. Do not route the drain line through areas that could be damaged by leaking condensate.
3. Some jurisdictions may require that the condensate be neutralized before being disposed of. Dispose of condensate in accordance with local codes.
4. Do not route, or terminate, the condensate drain line in areas subjected to freezing temperatures.
5. If the point of condensate disposal is above the trap, it will be necessary to use a condensate pump to move the condensate to the drain. In such cases, select a condensate pump that is approved for use with condensing boilers. If overflow from this pump would result in property damage, select a pump with an overflow switch and use this switch to shut down the boiler. Alternatively, if heat is a necessity, use the overflow switch to trigger an alarm.
6. Do not attempt to move the trap from the location shown in Figure 7.47. Do not attempt to substitute another trap for the one provided with the boiler.
7. The trap vent is connected to a barbed fitting attached to the right side panel with rubber tubing and must be left open for the trap to work properly.



**WARNING** Asphyxiation Hazard. Failure to install the condensate drain in accordance with the above instructions could cause flue gas to enter the building, resulting in personal injury or death.

**NOTICE** Boiler condensate is corrosive. Route condensate drain line in a manner such that any condensate leakage will not cause property damage.

Some jurisdictions may require that condensate be neutralized prior to disposal.

Use materials approved by the authority having jurisdiction.

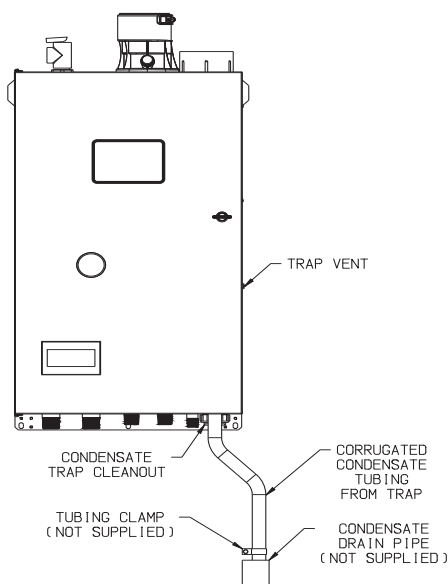


Figure 7.47: Condensate Piping Arrangement

## VII. Venting K. Removing an Existing Boiler From a Common Chimney (continued)

### K. Removing an Existing Boiler From a Common Chimney

This section only applies if this boiler is replacing an existing boiler that is being removed from a common chimney.

In some cases, when an existing boiler is removed from a common chimney, the common venting system may be too large for the remaining appliances. At the time of removal of an existing boiler, the following steps shall be followed with each appliance remaining connected to the common venting system placed in operation, while the other appliances remaining connected to the common venting system are not in operation.

- (a) Seal any unused openings in the common venting system.
- (b) Visually inspect the venting system for proper size and horizontal pitch and determine there is no blockage or restriction, leakage, corrosion and other deficiencies which could cause an unsafe condition.
- (c) Insofar as practical, close all building doors and windows and all doors between the space in which all the appliances remaining connected to the common venting system are located and other spaces of the building. Turn on clothes dryers and any appliance not connected to the common venting system. Turn on any exhaust fans, such as range hoods and bathroom exhausts, so they will operate at maximum speed. Do not operate a summer exhaust fan. Close fireplace dampers.
- (d) Place in operation the appliance being inspected. Follow the lighting instructions. Adjust thermostat so the appliance will operate continuously.
- (e) Test for spillage at the draft hood relief opening after 5 minutes of main burner operation. Use the flame of a match or candle, or smoke from a cigarette, cigar, or pipe.
- (f) After it has been determined that each appliance remaining connected to the common venting system properly vents when tested as outlined above, return doors, windows, exhaust fans, fireplace dampers and any other gas-burning appliances to their previous condition of use.
- (g) Any improper operation of the common venting system should be corrected so the installation conforms with the National Fuel Gas Code, ANSI Z223.1. When re-sizing any portion of the common venting system, the common venting system should be re sized to approach the minimum size as determined using the appropriate tables in Part 11 of the National Fuel Gas Code, ANSI Z223.1.



**WARNING**

**Never common vent this boiler with other appliances.**

Au moment du retrait d'une chaudière existante, les mesures suivantes doivent être prises pour chaque appareil toujours raccordé au système d'évacuation commun et qui fonctionne alors que d'autres appareils toujours raccordés au système d'évacuation ne fonctionnent pas:

- (a) Sceller toutes les ouvertures non utilisées du système d'évacuation.
- (b) Inspecter de façon visuelle le système d'évacuation pour déterminer la grosseur et l'inclinaison horizontale qui conviennent et s'assurer que le système est exempt d'obstruction, d'étranglement, de fuite, de corrosion et autres défaillances qui pourraient présenter des risques.
- (c) Dans la mesure du possible, fermer toutes les portes et les fenêtres du bâtiment et toutes les portes entre l'espace où les appareils toujours raccordés au système d'évacuation sont installés et les autres espaces du bâtiment. Mettre en marche les sècheuses, tous les appareils non raccordés au système d'évacuation commun et tous les ventilateurs d'extraction comme les hottes de cuisinière et les ventilateurs des salles de bain. S'assurer que ces ventilateurs fonctionnent à la vitesse maximale. Ne pas faire fonctionner les ventilateurs d'été. Fermer les registres des cheminées.
- (d) Mettre l'appareil inspecté en marche. Suivre les instructions d'allumage. Régler le thermostat de façon que l'appareil fonctionne de façon continue.
- (e) Faire fonctionner le brûleur principal pendant 5 min ensuite, déterminer si le coupe-tirage déborde à l'ouverture de décharge. Utiliser la flamme d'une allumette ou d'une chandelle ou la fumée d'une cigarette, d'un cigare ou d'une pipe.
- (f) Une fois qu'il a été déterminé, selon la méthode indiquée ci-dessus, que chaque appareil raccordé au système d'évacuation est mis à l'air libre de façon adéquate. Remettre les portes et les fenêtres, les ventilateurs, les registres de cheminées et les appareils au gaz à leur position originale.
- (g) Tout mauvais fonctionnement du système d'évacuation commun devrait être corrigé de façon que l'installation soit conforme au National Fuel Gas Code, ANSI Z223.1/NFPA 54 et (ou) aux codes d'installation CAN/CSA-B149.1. Si la grosseur d'une section du système d'évacuation doit être modifiée, le système devrait être modifié pour respecter les valeurs minimales des tableaux pertinents de l'appendice F du National Fuel Gas Code, ANSI Z223.1/NFPA 54 et (ou) des codes d'installation CAN/CSA-B149.1.

---

## VIII. Gas Piping

---



**Explosion Hazard. Failure to properly pipe gas supply to boiler may result in improper operation or leaks of flammable gas.**

**Gas supply to boiler and system must be absolutely shut off prior to installing or servicing boiler gas piping.**

**Always assure gas piping is absolutely leak free and of the proper size and type for the connected load.**

**Use a thread compound compatible with liquefied petroleum gas. Failure to use proper thread compounds on all gas connectors may result in leaks of flammable gas.**

**If inlet pressure is above 1/2 psig (3.4 kPa) an additional gas pressure regulator is required. Consult gas supplier.**

**Size corrugated stainless steel tubing (CSST) to ensure proper capacity and minimize flow restrictions.**

Gas piping to the boiler must be sized to deliver adequate gas for the boiler to fire at the nameplate input at an inlet pressure between the minimum and maximum values shown in Table 8.2. When sizing, also consider other existing and expected future gas utilization equipment (i.e. water heater, cooking equipment). For more information on gas line sizing, consult the utility or the National Fuel Gas Code, NFPA54/ANSI Z223.1, and/or CAN/CSA B149.1 Natural Gas and Propane Installation Code.

Figure 8.1 shows typical gas piping connection to the boiler. A sediment trap must be installed upstream of all gas controls. Install a manual shut-off valve (provided by installer) outside the jacket with a ground joint union as shown. All above ground gas piping upstream from manual shut-off valve must be electrically continuous and bonded to a grounding electrode. Refer to National Electrical Code, NFPA 70.

The boiler and its gas connection must be leak tested before placing the boiler in operation. When doing this, the boiler and its individual shut-off must be disconnected from the rest of the system during any pressure testing of that system at pressures in excess of 1/2 psi (3.5kPa). When pressure testing the gas system at pressures of 1/2 psi (3.5kPa) or less, isolate the boiler from the gas supply system by closing its individual manual shut-off valve. Locate leaks using approved combustible gas non-corrosive leak detector solution.



**Explosion Hazard. Do not use matches, candles, open flames or other ignition source to check for leaks.**



**If gas pressure in the building is above ½ psig (3.4 kPa), an additional gas pressure regulator is required. Using one additional regulator for multiple gas appliances may result in unsafe boiler operation. The additional regulator must be able to properly regulate gas pressure at the input of the smallest appliance. If the regulator can not do this, two or more additional regulators are required. Consult regulator manufacturer and/or local gas supplier for instructions and equipment ratings.**

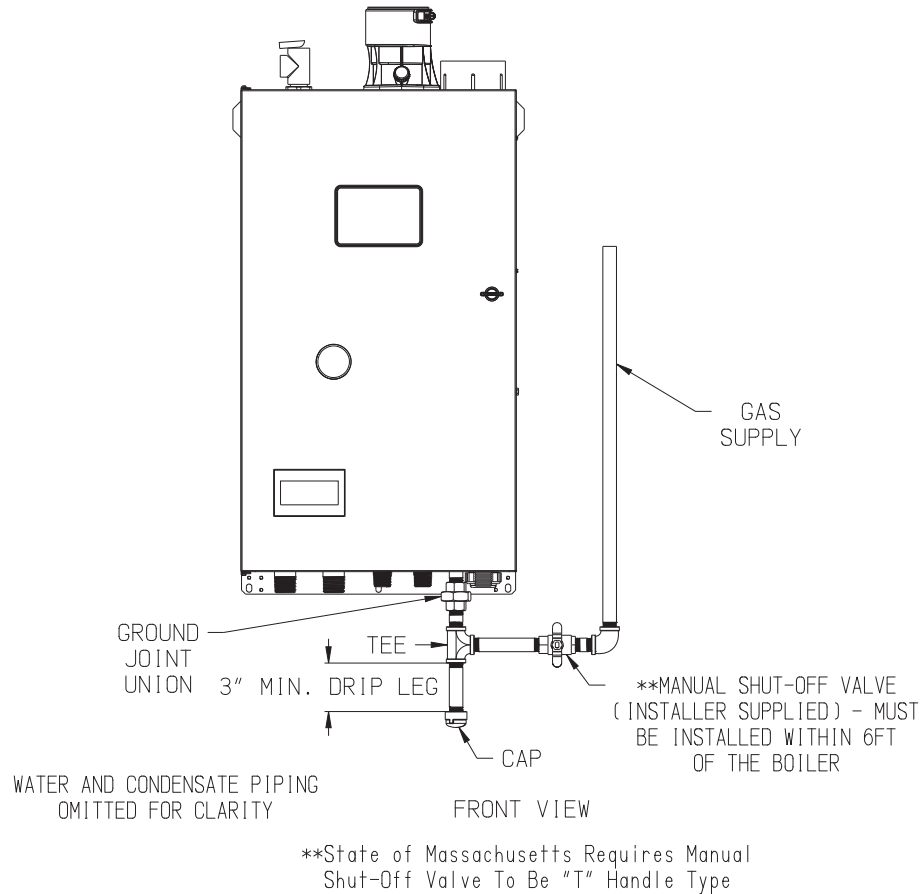
## VIII. Gas Piping (continued)



**CAUTION** Support the weight of the gas line piping independently from the boiler gas connection fitting located on the bottom of the boiler.

If an additional regulator is used to reduce boiler inlet pressure below 1/2 psig (3.4 kPa) it must be at least 6 to 10 ft. upstream of the boiler.

It is very important that the gas line is properly purged by the gas supplier or utility company.



**Figure 8.1: Gas Connection to Boiler**

**NOTICE** Install 1/2" ground joint union (nut side down) as shown in Figure 8.1. Failure to do so will make it difficult or impossible to remove burner for servicing.

**Table 8.2: Minimum and Maximum Inlet Pressures**

Model	Max. (Natural & LP)	Min. (Natural)	Min. (LP)
135-180	14.0"	2.5"	11.0"

---

## IX. System Piping

---

### A. General System Piping Precautions



Failure to properly pipe boiler may result in improper operation and damage to boiler or structure.

- Install boiler so that the gas ignition system components are protected from water (dripping, spraying, rain, etc.) during boiler operation and service (circulator replacement, etc.).
- Oxygen contamination of boiler water will cause corrosion of iron and steel boiler components and can lead to boiler failure. Warranty does not cover problems caused by oxygen contamination of boiler water or scale (lime) build-up caused by frequent addition of water.



1. The heat transfer-medium must be water or other nontoxic fluid having a toxicity rating or Class of 1, as listed in *Clinical Toxicology of Commercial Products*, 5th edition.
2. The pressure of the heat transfer medium must be limited to a maximum of 30 PSIG by an approved safety or relief valve.

### WATER QUALITY AND BOILER WATER ADDITIVES IMPORTANT NOTE

The heat exchanger used in this boiler is made from stainless steel coils having relatively narrow waterways. Once filled with system water, it will be subjected to the effects of corrosion, as well as fouling from any debris introduced from the system. Take the following precautions to minimize the chance of severe heat exchanger damage caused by corrosion and/or overheating:

1. Flush the system before connecting the boiler - In a replacement installation, flushing the system will remove impurities, such as sediment, solder flux, metal shavings, and traces of old boiler additives. Even if the system is new, do not omit this step – new systems will contain flux and may even contain some of the other impurities listed above. Flush the system completely and repeat if necessary to completely remove these contaminants. If necessary, a cleaning agent may be used to assist in system cleaning. See Section XII (“Start-up and Check-out”) for recommended cleaners.
2. Make sure that the system is tight - This is the single most important guideline. Tap water contains dissolved oxygen which causes corrosion. In a tight system, this oxygen comes out of solution and is quickly removed from the system through the automatic air vent. The system then remains essentially free of oxygen. If the system is not tight, however, frequent additions of make-up water can expose the heat exchanger to oxygen on a continuous basis. In addition, frequent additions of hard make-up water can cause calcium deposits to collect in the heat exchanger, causing severe damage. To minimize additions of make-up water:
  - Inspect the system thoroughly for leaks before placing it in service.
  - If the system includes underground piping, or other piping in which a leak might go undetected, consider isolating the boiler from the system with a heat exchanger.
  - Make sure that the expansion tank is properly sized and in good condition. If it is not, the relief valve may open frequently, resulting in regular additions of make-up water.
  - If an automatic fill valve is installed, installation of a water meter in the fill line is strongly recommended so that routine additions of make-up water can be detected and their cause corrected.
3. Non-Metallic Tubing - Even if the system is tight, oxygen can be introduced into the system through some types of non-metallic tubing used in radiant or snow melt systems. Other nonmetallic tubing is equipped with an oxygen barrier to prevent migration of oxygen into the water. If the boiler is to be installed in a system containing non-metallic tubing without an oxygen barrier, it must be isolated from the boiler with a heat exchanger as shown in Figure 9.8.
4. Water Chemistry, Antifreeze, and Boiler Water Additives – Improper boiler water chemistry can cause the heat exchanger damage described above, as well as deterioration of seals. Observe the water chemistry requirements shown in Section XII (“Start-up and Check-out”).

## IX. System Piping (continued)

### B. Standard Piping Installation Requirements

Observe the following requirements when installing the boiler piping:

1. Relief Valve (Required) – The relief valve is shipped loose and must be installed in the location shown in Figure 9.0. Pipe the outlet of the relief valve to a location where water or steam will not create a hazard or cause property damage if the valve opens. The end of the discharge pipe must terminate in unthreaded pipe. If the relief valve discharge is not piped to a drain, it must terminate at least 6" above the floor. Do not run the discharge piping through an area that is prone to freezing. The termination of the relief valve must be in an area where it is not likely to become plugged by debris. The relief valve supplied with the boiler is set to open at 30 psi. If it is replaced, the replacement must have a setting less than or equal to the maximum allowable working pressure (MAWP) shown on the ASME data plate located on the left side of the heat exchanger.



**Explosion / Scald Hazard. Pipe relief valve discharge to a location where the potential of severe burns is eliminated.**

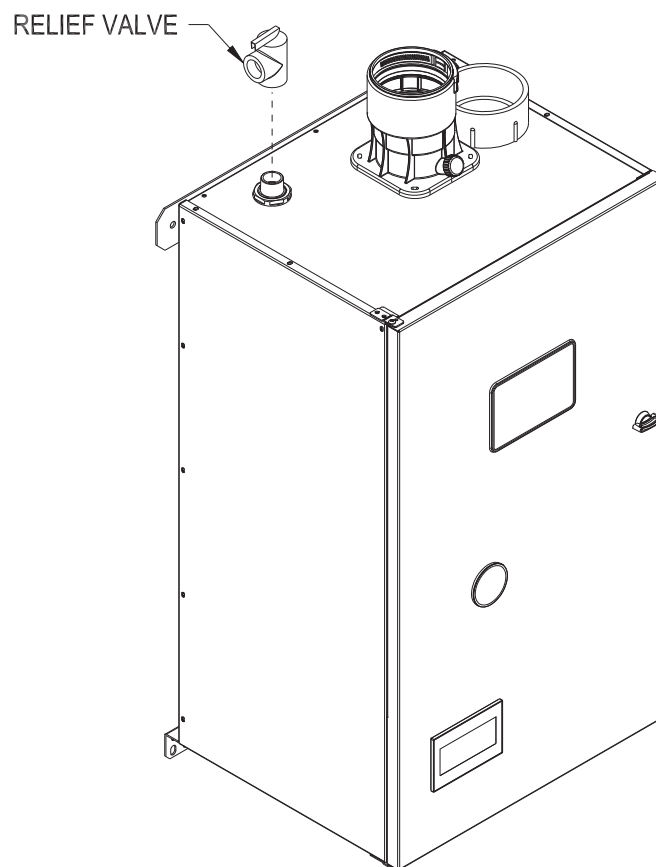
- Do not install a relief valve having a setting greater than the MAWP shown on the rating plate.
  - Do not install a valve in the relief valve discharge line.
  - Do not install relief valve in a location other than that specified by the factory.
  - Do not plug the relief valve discharge.
2. Circulator (required) – The boiler loop circulator is factory installed inside the boiler cabinet. Usually at least one addition circulator (not supplied) will be required for the system to work properly. See the following section for more information.
  3. Expansion Tank (required) – If this boiler is replacing an existing boiler with no other changes in the system, the old expansion tank can generally be reused. If the expansion tank must be replaced, consult the expansion tank manufacturer's literature for proper sizing. If using antifreeze, account for additional expansion of glycol solution when sizing an expansion tank. In a typical residential heating system, a glycol mixture has an expansion rate about 1.2 times that of water alone, therefore a tank for an anti-freeze system should be at least 1.2 times greater in size.
  4. Fill Valve (required) – Either a manual or automatic fill valve may be used, but a manual valve is preferred because it eliminates unmonitored additions of make-up water to the system. The ideal location for the fill valve is at the expansion tank. If using antifreeze with automatic fill valve, it is recommended to install a water meter to monitor makeup water. Antifreeze concentration will decrease as makeup water is added. If using antifreeze, local codes often require a backflow preventer or disconnect from city water.
  5. Automatic Air Vent (required) – At least one automatic air vent is required. Manual air vents will usually be required in other parts of the system to remove air during initial fill.
  6. Manual Reset High Limit (required by some codes) - This control is required by ASME CSD-1 and some other codes. Install the high limit in the boiler supply piping just above the boiler with no intervening valves. Set the manual reset high limit to 200°F. Wire the limit per Figure 11.3 in the Wiring section.
  7. Isolation Valves (recommended) - Isolation valves are useful when the boiler must be drained, as they will eliminate having to drain and refill the entire system.
  8. Strainer (recommended) – Install a Y Strainer, or other suitable strainer, to prevent any system debris from entering the boiler and fouling the water passages. Note that some strainers have a significant pressure drop, which may impact the ability of the boiler pump to obtain the required flow. See Part C of this section for additional information.

## IX. System Piping (continued)

9. Drain Valve (required) – Install the drain valve (provided by the installer) as shown in Figure 9.2.
10. Low Water Cut-off (may be required by local jurisdiction) – Protection of this boiler against low water and/or inadequate flow is provided by the UL353 certified flow switch built into the boiler. This is a water tube boiler and this flow switch is therefore the only effective way to provide such protection. Section HG614(c) of the 2015 ASME boiler and Pressure Vessel Code recognizes the use of a listed flow switch in lieu of a low water cut-off on water tube boilers.

In the event that a local jurisdiction insists upon the installation of a low water cut-off with this boiler, refer to Part XI and the low-water cut-off manufacturer's instructions for proper wiring. Install the low water cut-off in the supply piping at the point prescribed the local jurisdiction (generally at a point above the boiler).

If a probe type low water cut-off is used, be certain that it is located at a point in the piping from which air can escape to an automatic air vent. Generally, this means that there should be no down-turns in the piping between the low water cut-off and the point where the automatic air vent is installed. Failure to do this may result in nuisance boiler shut-downs due to small amounts of air trapped around the probe.



**Figure 9.0: Factory Supplied Piping and Trim Installation**



## IX. System Piping (continued)

### C. Near Boiler Piping Design

Proper operation of this boiler requires that the water flow rate through it remain within the limits shown in Table 9.1 any time the boiler is firing. At flow rates below the minimum shown, the boiler's flow switch and/or temperature rise limit function may prevent the boiler from firing. Flow rates through the boiler in excess of the maximum shown in Table 9.1 can result in excessive noise or erosion damage to piping.

There are two basic methods that can be used to pipe this boiler into the system. Method #1 (primary-secondary piping) is always preferred. Additional information on hydronic system design can be found in the I=B=R Guide RHH published by the Air-Conditioning, Heating and Refrigeration Institute (AHRI).

**Table 9.1 Water Flow Rate Limits**

Model	Flow (GPM)	
	Minimum	Maximum
135	6.2	13.3
150	7.7	13.3
180	9.3	13.3

#### Method 1: Primary/Secondary Piping (Strongly Recommended)

This method is shown in Figure 9.2. In this system, the flow rate through the boiler ("secondary loop") is completely independent of the flow rate through the system ("primary loop"). Use the following guidelines to ensure that the boiler will have the required flow shown in Table 9.1 regardless of the flow in the heating system.

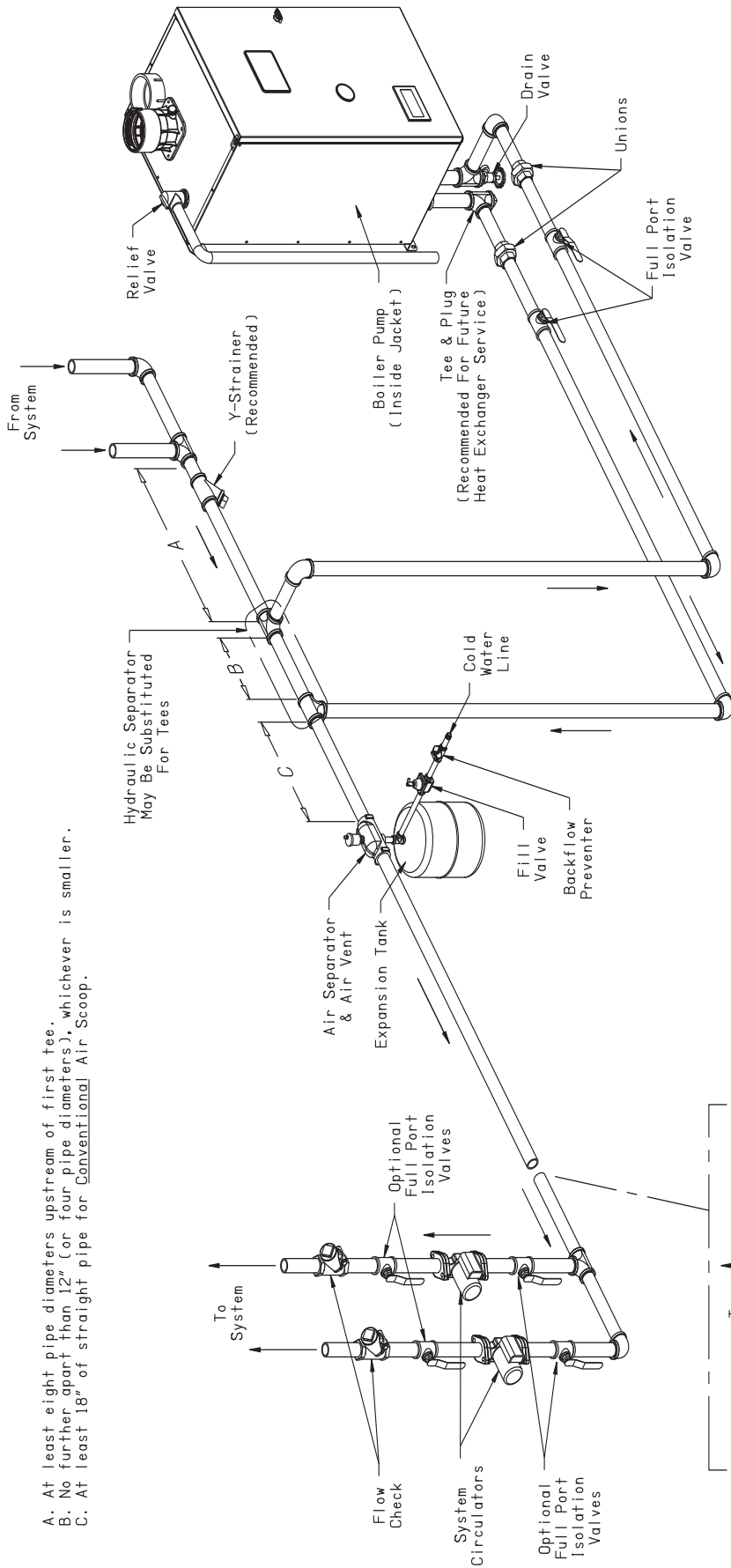
1. System Loop Piping - Size the system circulator and piping to obtain the design flow rate through the heating system as you would on any other heating system. All piping between the expansion tank and secondary connection tees must be at least 1". In order to keep the flow rates in the system and boiler loops independent of each other, provide at least 8 diameters of straight pipe upstream of the first tee and 4 diameters downstream of the second tee. Keep the distance between the expansion tank and the first secondary tee as short as practical.
2. Boiler Loop Piping – All boilers are supplied with a built in circulator which will deliver the flow required by Table 9.1 provided both of the following conditions are met:
  - All piping in the boiler loop has a nominal size of at least 1"
  - The equivalent length of all piping in the boiler loop is 60 ft or less.

To verify that the 60 ft, equivalent length is not exceeded, do the following:

- a. Count all fittings in the planned boiler loop (the shaded piping in Figure 9.5).
- b. Using Table 9.3, find the equivalent lengths of all fittings in the secondary loop. Total these equivalent lengths and add them to the total length of planned straight pipe in the secondary loop.
- c. The result is the total equivalent length of the planned boiler loop. If the equivalent length calculated in (b) is under the limit shown in Table 9.4, the boiler pump will achieve a flow rate and temperature rise approximately equal to that shown in this table. Otherwise, the equivalent length must be reduced.

*Example – A 135MBH model is to be connected to a heating system as shown in Figure 9.5. A total of 20 ft of straight pipe will be installed between the boiler and the system loop.*

# IX. System Piping (continued)



- A. At least eight pipe diameters upstream of first tee.
- B. No further apart than 12" (or four pipe diameters), whichever is smaller.
- C. At least 18" of straight pipe for Conventional Air Scoop.

Notes:  
 1. Boiler Pump Located Inside Boiler Jacket.  
 2. Manual Air Vent Located On Top Of Heat Exchanger. See Figure 12.1.

**CAUTION**  
 It is the installers responsibility to select boiler piping configurations that provide the proper flow rates and performance for the boiler.

Figure 9.2: Piping Method #1 - Near Boiler Piping - Heating Only

## IX. System Piping (continued)

Count all fittings in the boiler loop (shaded in Figure 9.5):

4 90° Elbows

2 Turn in Tee

2 Isolation Valves

Note: Unions, Secondary Connection Tees, and factory supplied fittings are ignored.

Calculate total equivalent length from Table 9.3:

$20 \text{ ft Straight Pipe} + 4 \text{ Elbows} \times 2.8 + 2 \text{ Turn in Tee} \times 5.5 + 2 \text{ Valves} \times 0.7 = 43.6 \text{ Equivalent Feet}$

Since the total equivalent length is less than 60 ft, flow through boiler loop meets requirements in Table 9.1.

3. Hydraulic Separators—Hydraulic separators serve the same purpose as the closely spaced tees connecting the boiler and system loops in Figure 9.2. They also generally provide effective connection points for automatic air elimination devices and an expansion tank. These separators are available from several sources and may be used in place of the closely spaced tees shown in Figure 9.2. When a hydraulic separator is used in place of the tees, the 60 ft equivalent length limitation still applies. Select a hydraulic separator having 1" or larger boiler connections that is designed for the boiler flow rates shown in Table 9.1.

**Table 9.3: Equivalent Lengths for Selected Valves and Fittings**

(May Be Used for Copper or Threaded Fittings)

Fitting	Pipe Size	Equivalent Length (ft)
90° Elbow	1"	2.8
45° Elbow	1"	1.4
90° Turn in Tee	1"	5.5
Run of Tee	1"	1.8
Gate Valve (Open)	1"	0.7
Full Port Ball Valve	1"	0.7
Y-Strainer*	1"	7.0

\* Based on Cv of 20. Pressure drop through strainers varies widely. 7 ft equivalent length may be assumed for strainers having a published Cv greater than 20.

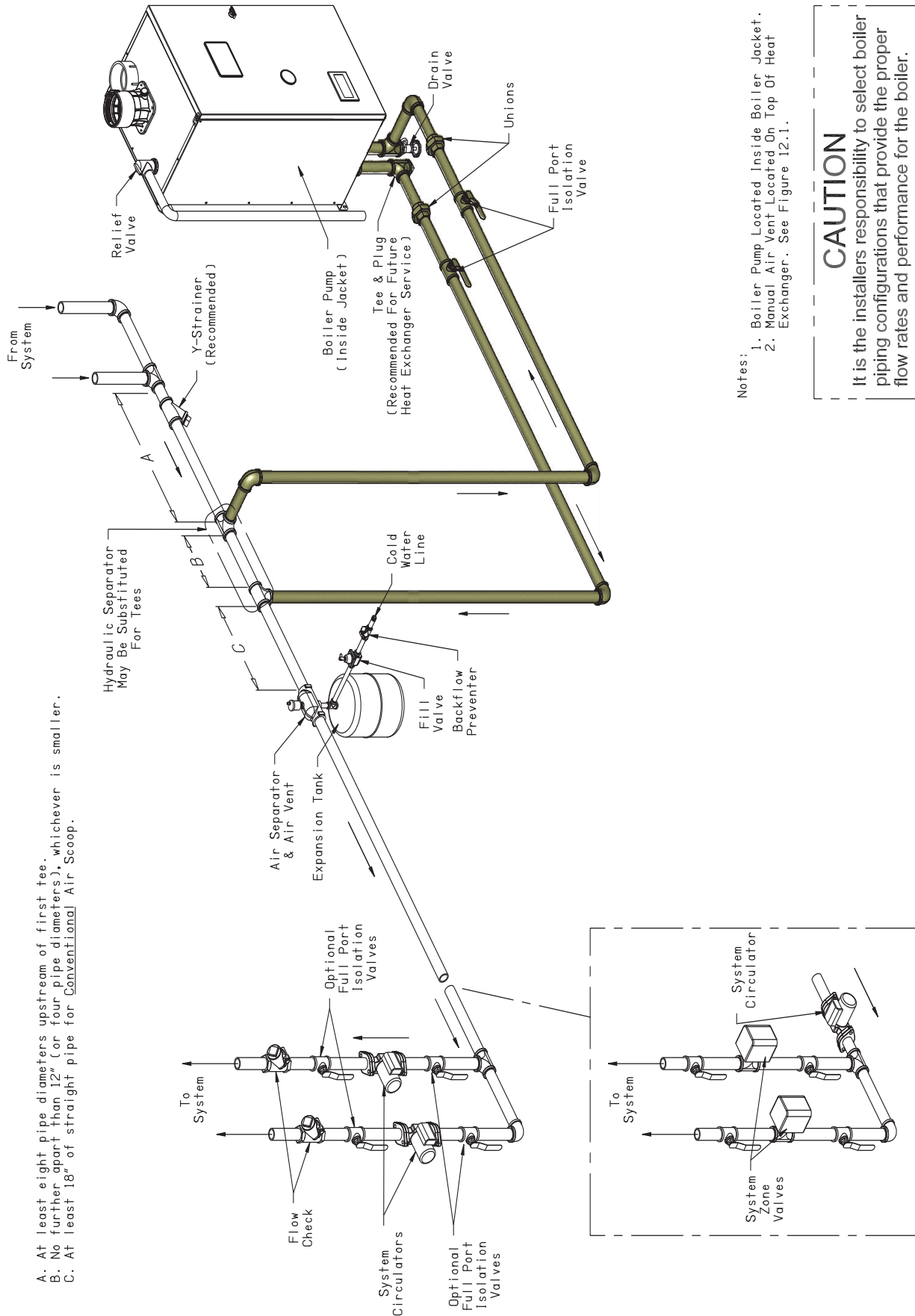
**Table 9.4a: Flow Available with Boiler Loop  
Equivalent Length of 30 ft or Less**

Boiler Model	Approx. Flow (GPM)	Approx. Rise (°F)
135	8.6	25
150	11.8	23
180	11.8	28

**Table 9.4b: Flow Available with Boiler Loop  
Equivalent Length of 60 ft or Less**

Boiler Model	Approx. Flow (GPM)	Approx. Rise (°F)
135	8.3	26
150	11.1	24
180	11.1	29

# IX. System Piping (continued)



- A. At least eight pipe diameters upstream of first tee.
- B. No further apart than 12" (or four pipe diameters), whichever is smaller.
- C. At least 18" of straight pipe for Conventional Air Scoop.

Notes:  
 1. Boiler Pump Located Inside Boiler Jacket.  
 2. Manual Air Vent Located On Top Of Heat Exchanger. See Figure 12.1.

**CAUTION**  
 It is the installers responsibility to select boiler piping configurations that provide the proper flow rates and performance for the boiler.

**Figure 9.5: Piping Method #1 - Near Boiler Piping - Shaded Boiler Loop**

## IX. System Piping (continued)

### Method 2: Direct Connection to Heating System (Generally NOT Recommended)

In some relatively rare cases it may be possible to connect this boiler directly to the heating system as is done with conventional boilers (Figure 9.6). If this is done, the flow rate through the boiler will equal the flow rate through the system. The flow rate through the system must therefore always remain within the limits shown in Table 9.1. For this reason, the pressure drop through the entire system must be known.

This method is generally not recommended because it is often very difficult to accurately calculate the pressure drop through the system. In replacement installations, it may be impossible to get an accurate measurement of the amount of piping and number of fittings in the system. In addition, if the system is zoned, the system flow may drop well below the minimum required when only one zone is calling for heat.

The one advantage to this method is its installation simplicity. It may make sense to use this method when the boiler is to be installed with a new single zone system having a low-pressure drop.

Figure 9.7 shows the performance curve for the pump in each boiler model, taking into account the pressure drop through the boiler's heat exchanger and internal piping. These curves therefore show the flow that can be achieved through the boiler as a function of the pressure drop through the connected piping. Calculation of the system pressure drop must be performed by someone having familiarity with pressure drop calculations, such as an HVAC engineer.

**NOTICE** Where it is not possible to install a separate boiler loop, the system circulator must be sized to ensure that the flow through the boiler stays within the defined parameters to prevent overheating when the boiler is fired at its full rated input. Install a flow meter to measure the flow, or fire the boiler at full rate and ensure the boiler delta T does not exceed 35°F (19°C).

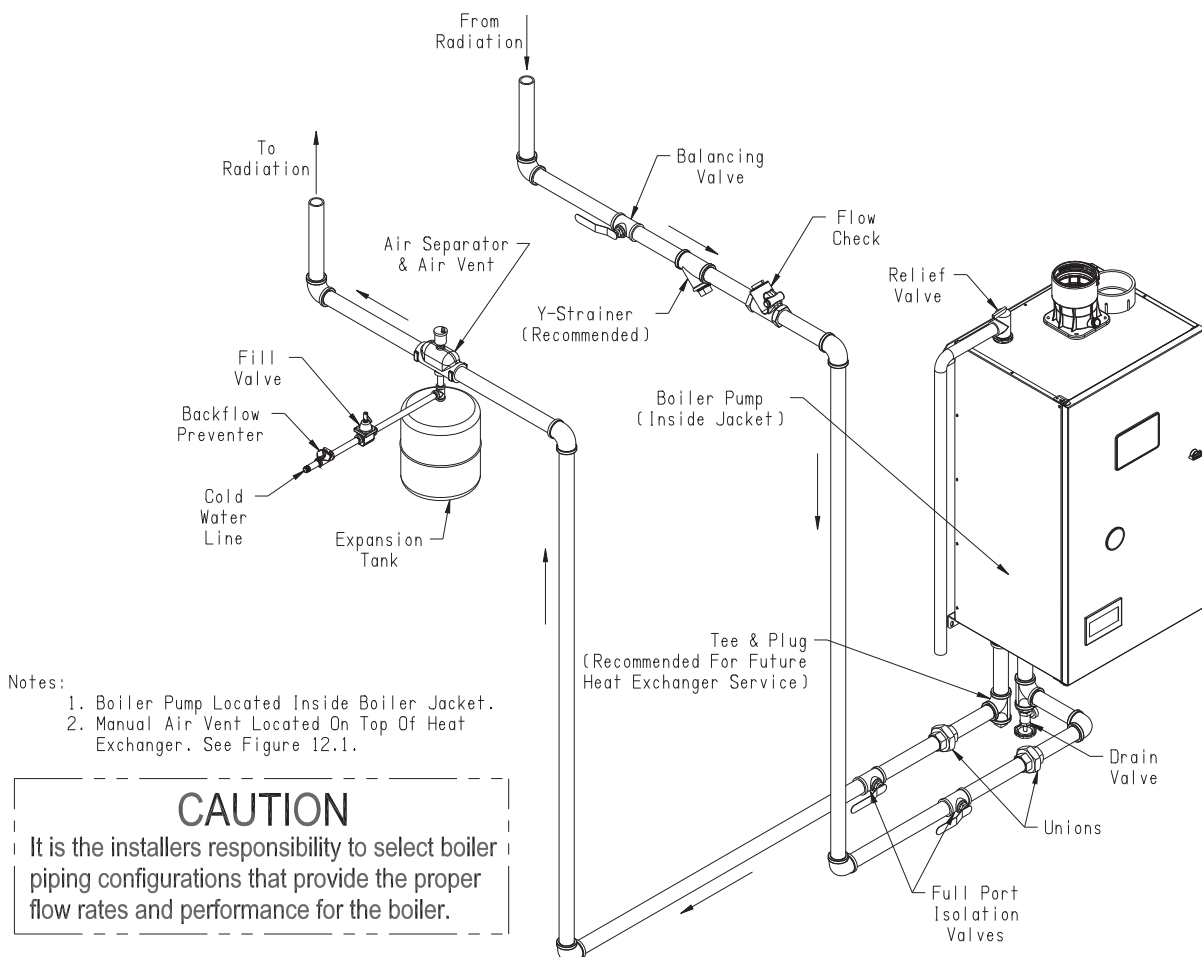


Figure 9.6: Piping Method #2 - Direct Connection of Boiler to Heating System

## IX. System Piping (continued)

**Note:** These curves show the flow that can be achieved through the boiler as a function of the pressure drop through the connected piping.

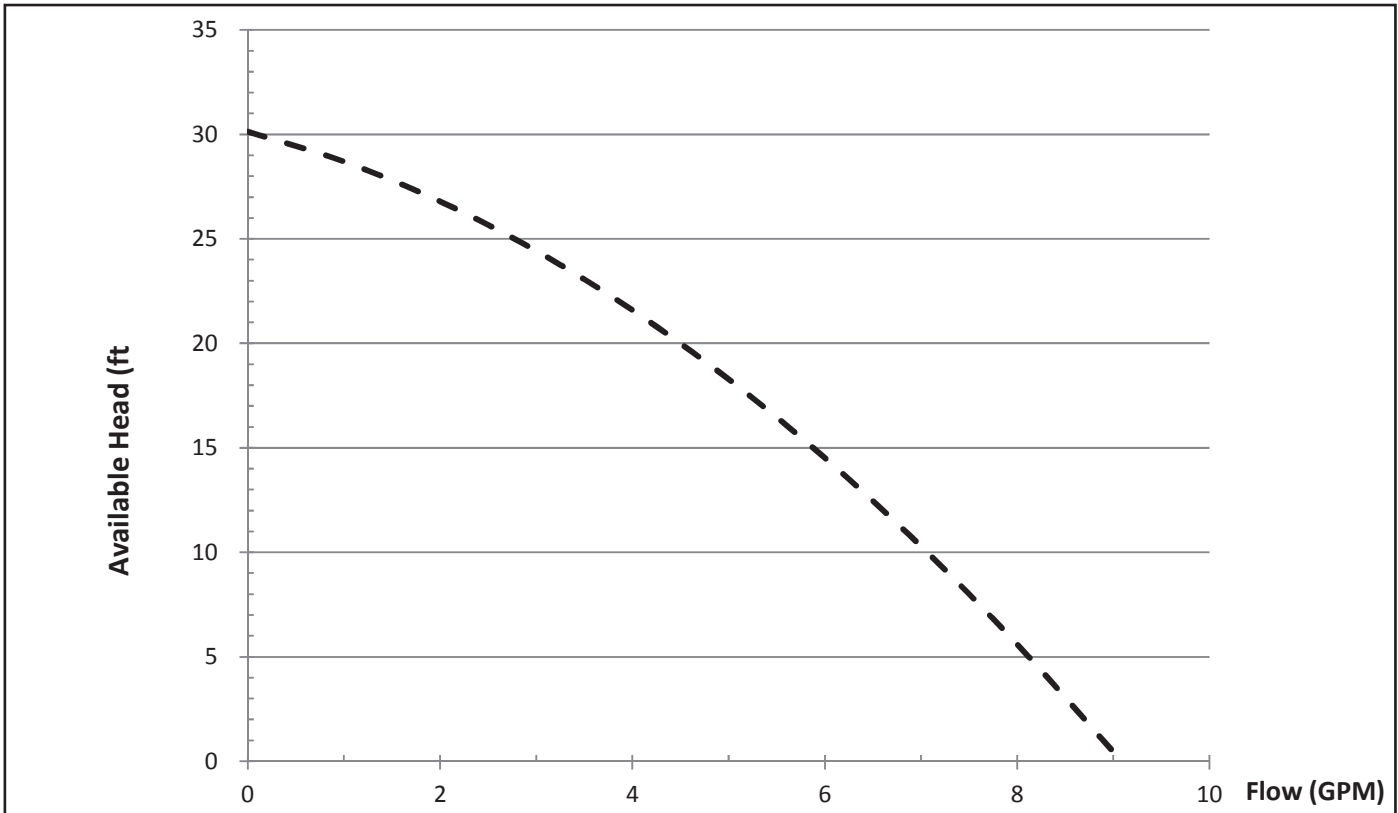


Figure 9.7a: 135 Net Circulator Performance Curve (Taco 0011)

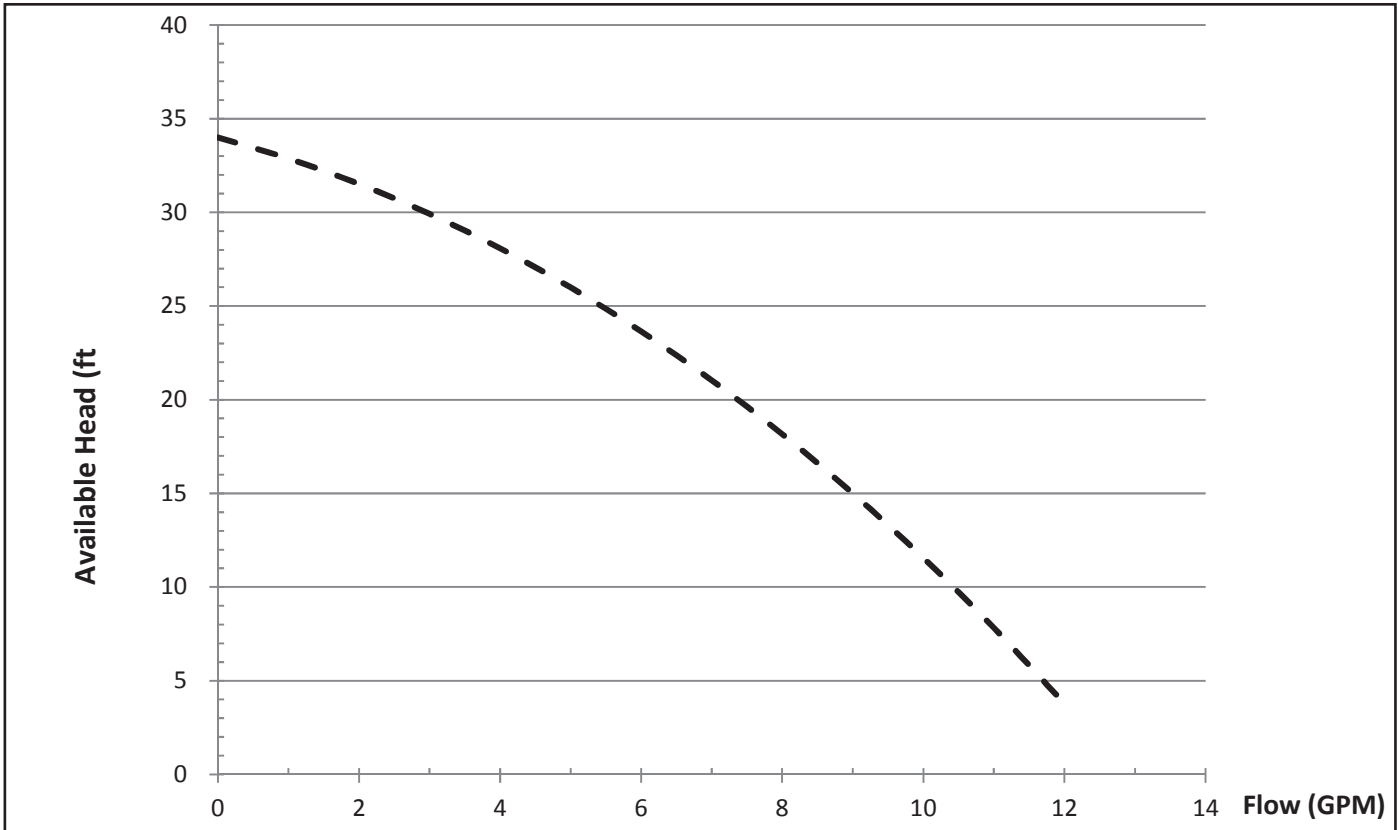


Figure 9.7b: 150/180 Net Circulator Curve (Taco 0013)

## IX. System Piping (continued)

### D. Piping for Special Situations

1. System containing oxygen - Many hydronic systems contain enough dissolved oxygen to cause severe corrosion damage to a boiler. Some examples include:

- Radiant systems that employ tubing without an oxygen barrier.
- Systems with routine additions of fresh water.
- Systems which are open to the atmosphere.

If the boiler is to be used in such a system, it must be separated from the oxygenated water being heated with a heat exchanger as shown in Figure 9.8. Consult the heat exchanger manufacturer for proper heat exchanger sizing as well as flow and temperature requirements. All components on the oxygenated side of the heat exchanger, such as the pump and expansion tank, must be designed for use in oxygenated water.

2. Piping with a Chiller - If the boiler is used in conjunction with a chiller, pipe the boiler and chiller in parallel. Use isolation valves to prevent chilled water from entering the boiler.
3. Air Handlers - Where the boiler is connected to air handlers through which refrigerated air passes, use flow control valves in the boiler piping or other automatic means to prevent gravity circulation during the cooling cycle.

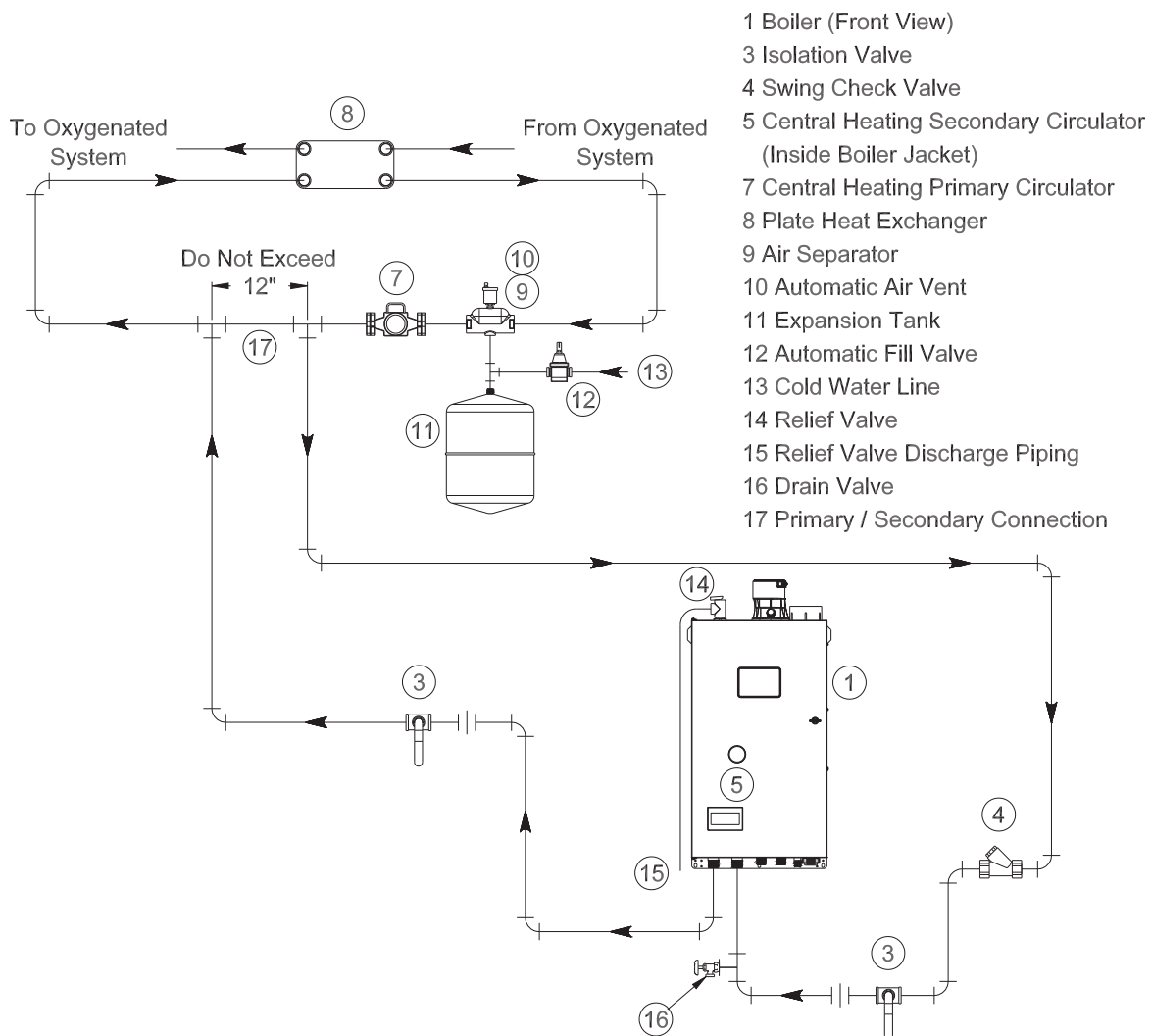


Figure 9.8: Isolation of the Boiler from Oxygenated Water with a Plate Heat Exchanger

---

## X. Domestic Hot Water Piping

---



**Scald Hazard.** Under certain conditions this boiler can deliver domestic hot water (DHW) at temperatures in excess of the DHW set point on the boiler control. An installer-supplied, ASSE 1017 or ASSE 1070 certified tempering valve is therefore **REQUIRED** as part of this boiler's installation.

- **Select and install tempering valve in accordance with the valve manufacturer's instructions and applicable local codes. In the absence of such codes follow the Uniform Plumbing Code (IAPMO/UPC-1). Also note that additional tempering valves may be required at the fixtures themselves.**

**NOTICE** DHW feature on this boiler is designed to only heat potable water (i.e. water from a well or water utility that is suitable for drinking) having the following characteristics:

- a. **Hardness less than 200PPM**
- b. **PH between 6 and 8**
- c. **Chloride level less than 80PPM.**

**Use of water not having these characteristics could result in premature failure of the DHW handling components in this boiler.**

- **Internal components near the Hot and Cold connections can be damaged by excessive heat during soldering. If copper adaptors are mounted directly on the combi, solder adjacent piping to these adaptors before installing them on the boiler. Failure to do so may cause internal leaks and/or other damage to the boiler.**

Install the domestic hot water piping as shown in Figure 10.1. Combi connections are 3/4" NPT male thread. The components in this system, and their functions are as follows:

1. ASSE 1070 or ASSE 1017 Listed Tempering Valve (Required) – This boiler is equipped with a control system that attempts to regulate the DHW outlet temperature to a DHW set point (default set point is 120F – see Section XIII for more information). As with all water heaters there are inherent limitations on the ability of the control system to accurately regulate water temperature to this set point under all conditions. Extremely low draw rates and transitions from heating to DHW are two examples of conditions that can cause the temperature of water leaving the boiler to significantly exceed the DHW set point. To minimize "spikes" in DHW temperature, a tempering valve is therefore required. Select and install in accordance with the valve manufacturer's instructions and applicable codes. Note that some codes require additional tempering devices at some of the fixtures as well.
2. Flow Restrictor (Optional) - If domestic hot water is drawn from at a rate in excess of the rating in Table 2.2, the temperature of the hot water may be too low to be of use. The use of a flow restrictor will help prevent this problem by limiting the rate at which water can pass through the DHW heat exchanger. If a restrictor is used, select one having a rating in GPM approximately equal to that shown in Table 2.2 at the desired temperature rise.
3. Pressure Relief Valve (Required) - Limits the pressure in the domestic hot water piping. Use a valve designed for DHW service, such as the Watts #3L or #53L. Note that this is a pressure relief valve, not a T&P valve. Select a valve with a pressure setting less than or equal to 145 psi. Pipe the discharge to a safe location using piping the same size as the discharge connection on the valve.
4. Hose Bib Valves (Recommended) - These valves permit the DHW plate heat exchanger be periodically "back flushed" to remove sediment.
5. Globe or Ball Valve (Recommended) - Used to aid in back flushing the heat exchanger and to isolate the DHW piping if it must be serviced. In addition, the upstream valve may be used to limit the DHW flow if necessary.
6. Thermal Expansion Tank (Required if a backflow preventer is installed) – If a back flow preventer or check valve is installed upstream of the cold connection, a thermal expansion tank will prevent the build-up of pressure in the DHW piping. Use a thermal expansion tank designed for use in potable water service.
7. Unions – Improve serviceability of DHW piping.



## X. Domestic Hot Water Piping (continued)

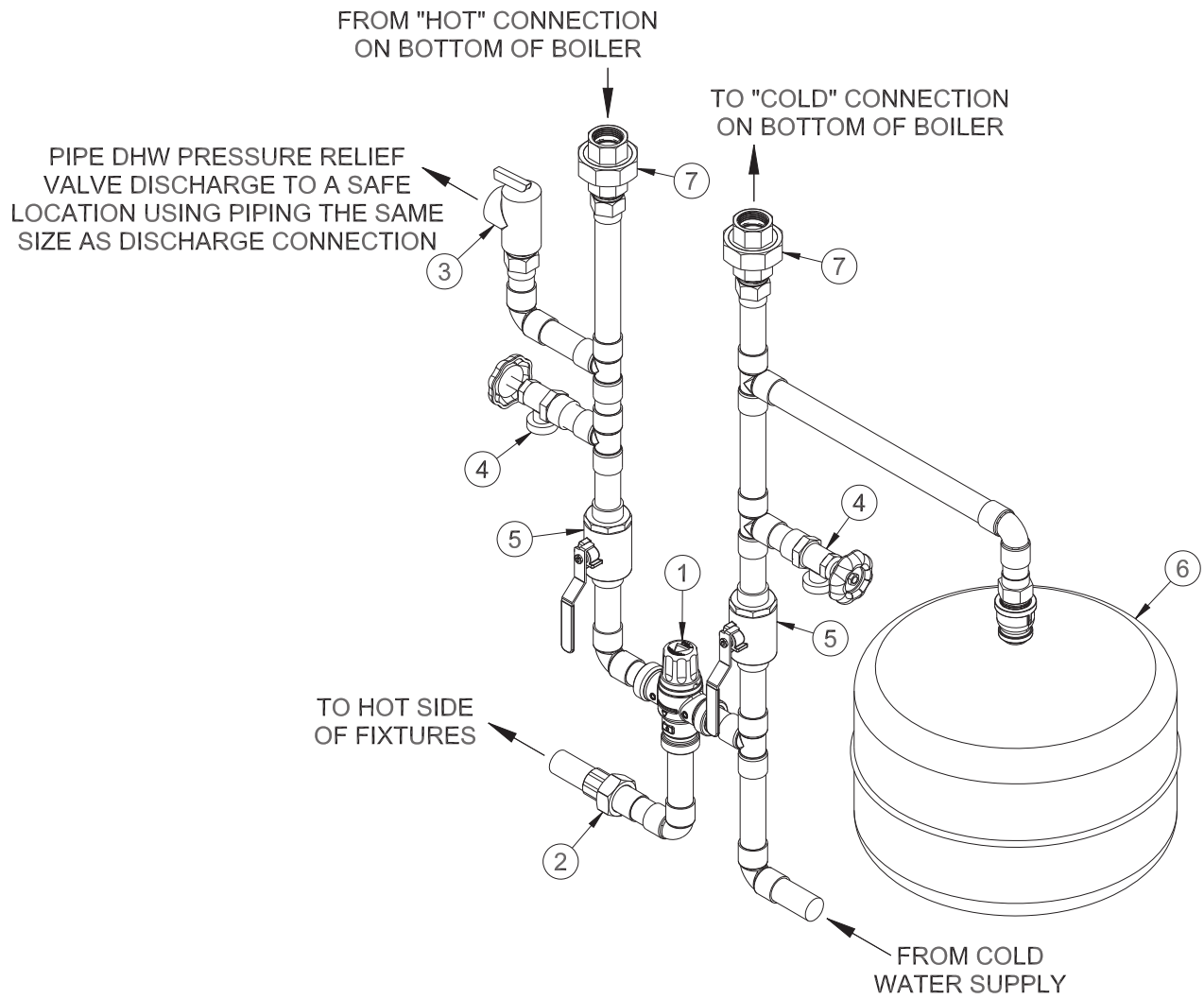


Figure 10.1: Domestic Hot Water Piping

---

## XI. Wiring

---



**DANGER** Electrical Shock Hazard. Positively assure all electrical connections are unpowered before attempting installation or service of electrical components or connections of the boiler or building. Lock out all electrical boxes with padlock once power is turned off.



**WARNING** All wiring and grounding must be done in accordance with the authority having jurisdiction or, in the absence of such requirements, with the National Electrical Code /NFPA 70). In Canada, all wiring and grounding must be done in accordance with the Canadian Electrical Code, Part 1 (CSA C22.1 - latest edition).

Failure to properly wire electrical connections to the boiler may result in serious physical harm.

Electrical power may be supplied from more than one circuit. Make sure all power is off before attempting any electrical work.

Each boiler must be protected with a properly sized over-current device.

Never jump out or make inoperative any safety or operating controls.

The wiring diagrams contained in this manual are for reference purposes only. Each boiler is shipped with a wiring diagram attached to the front door. Refer to this diagram and the wiring diagram of any controls used with the boiler. Read, understand and follow all wiring instructions supplied with the controls.

**NOTICE** This boiler is equipped with a listed high water temperature limit function. This limit provides boiler shutdown in the event the boiler water temperature exceeds the set point of the limit control. Certain Local Codes require an additional water temperature limit. If necessary, install an additional water temperature limit such as a Honeywell L4006 Aquastat. Wire as indicated in Figure 11.3.

Figure 11.1 shows the locations for making both high voltage and low voltage field connections.

1. Line Voltage (120 VAC) Field Connections – Leads for the line voltage connections are located in the junction box as shown in Figure 11.1. Provide a dedicated circuit for the boiler of 15A or greater. A service switch is recommended and is required by many local codes. Locate this switch in accordance with local codes or, in the absence of any, in a location where it can be safely accessed in an emergency involving the boiler. All 120VAC connections to the boiler itself are wire nut connections, except for the ground, which is a screw. The leads are color coded as follows:
  - 120VAC Hot - Black
  - 120VAC Neutral - White
  - System Pump Hot - Yellow

See Figure 11.2 for line voltage field connection wiring.

Note that the system circulator is field supplied and is the pump that, in most cases, actually circulates water through the radiation. The system pump is always on when the boiler is responding to a call for space heat. Maximum recommended current draw for the system pump is 2.0A.

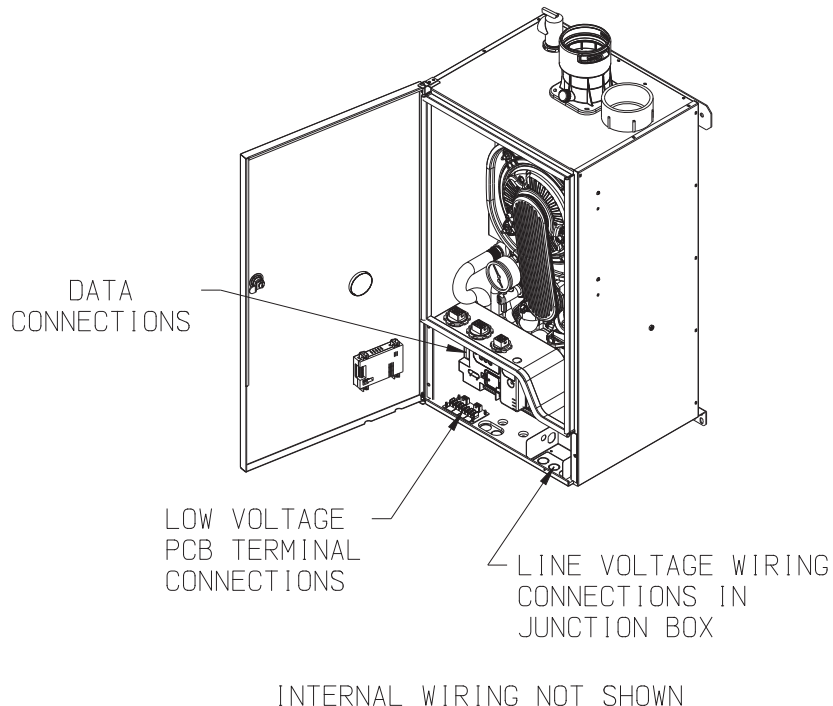
## XI. Wiring (continued)

2. Low Voltage Connections – Commonly used low voltage field connections are located on the low voltage PCB and are shown in Figure 11.3 and listed from left to right:

- 1 Heat T'Stat - 24VAC heating thermostat
- 2 Heat T'Stat - 24VAC heating thermostat
- 3 DHW Stat - No field connection
- 4 DHW Stat - No field connection
- 5 External Limit - Field supplied low voltage safety limit contacts (1)
- 6 External Limit - Field supplied low voltage safety limit contacts (2)
- 7 Outdoor Sensor - Tasseron TSA00AA Outdoor Temperature Sensor (1)
- 8 Outdoor Sensor - Tasseron TSA00AA Outdoor Temperature Sensor (2)

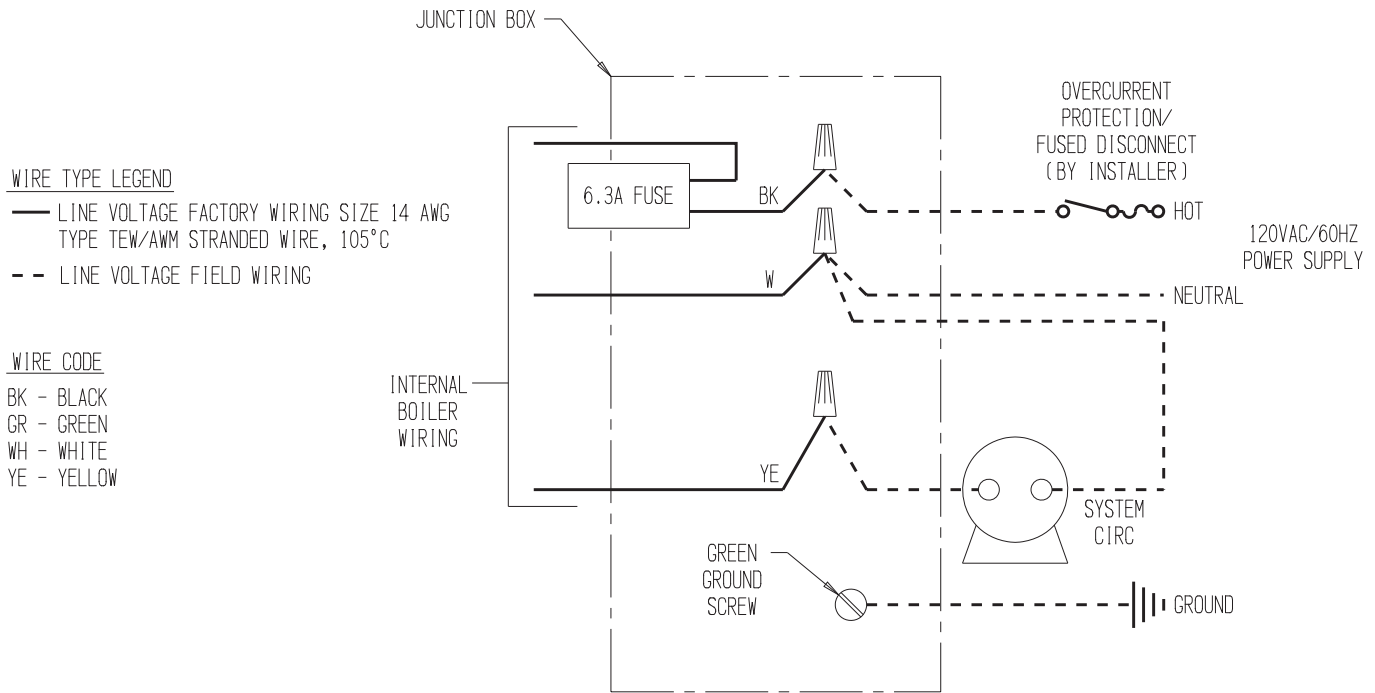
External power must not be applied to any of the low voltage terminals - doing so may damage the boiler control. Also note the following:

- a. External Limit - The external limit terminals are intended for use with a field supplied safety device, such as a manual reset high limit or low-water cut-off. When an external limit is used, the jumper between these two terminals must be removed. Failure to remove this jumper will render the external safety devices ineffective.
- b. Outdoor Sensor - Use only the Tasseron TSA00AA outdoor sensor supplied with the boiler. When this sensor is connected and enabled, the boiler will adjust the target supply water temperature downwards as the outdoor air temperature increases. This sensor should be located on the out side of the structure in an area where it will sense the average air temperature around the house. Avoid placing this sensor in areas where it may be covered with ice or snow. In general, locations where the sensor will pick up direct radiation from the sun should also be avoided. Avoid placing the sensor near potential sources of electrical noise such as transformers, power lines, and fluorescent lighting. Wire the sensor to the boiler using 22 gauge or larger wire. As with the sensor itself, the sensor wiring should be routed away from sources of electrical noise. Where it is impossible to avoid such noise sources, wire the sensor using a 2 conductor, UL Type CM, AWM Style 2092 shielded cable. Connect one end of the shielding on this cable to ground. See Section XIII of this manual for information on enabling the outdoor reset sensor.

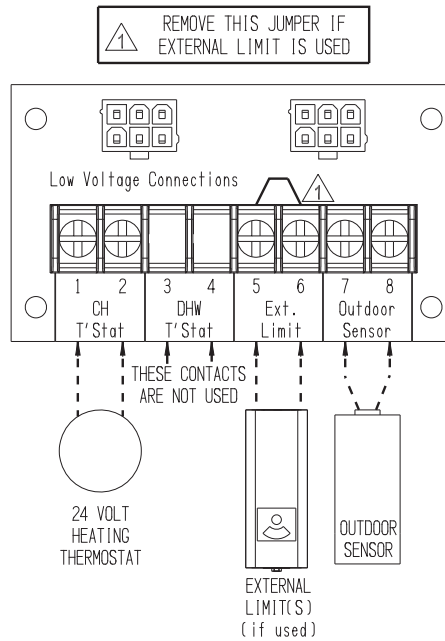


**Figure 11.1: Location of High and Low Voltage Field Electrical Connections**

## XI. Wiring (continued)




**Figure 11.2: Line Voltage Field Connections**



**Figure 11.3: Low Voltage PCB Terminal Connections**

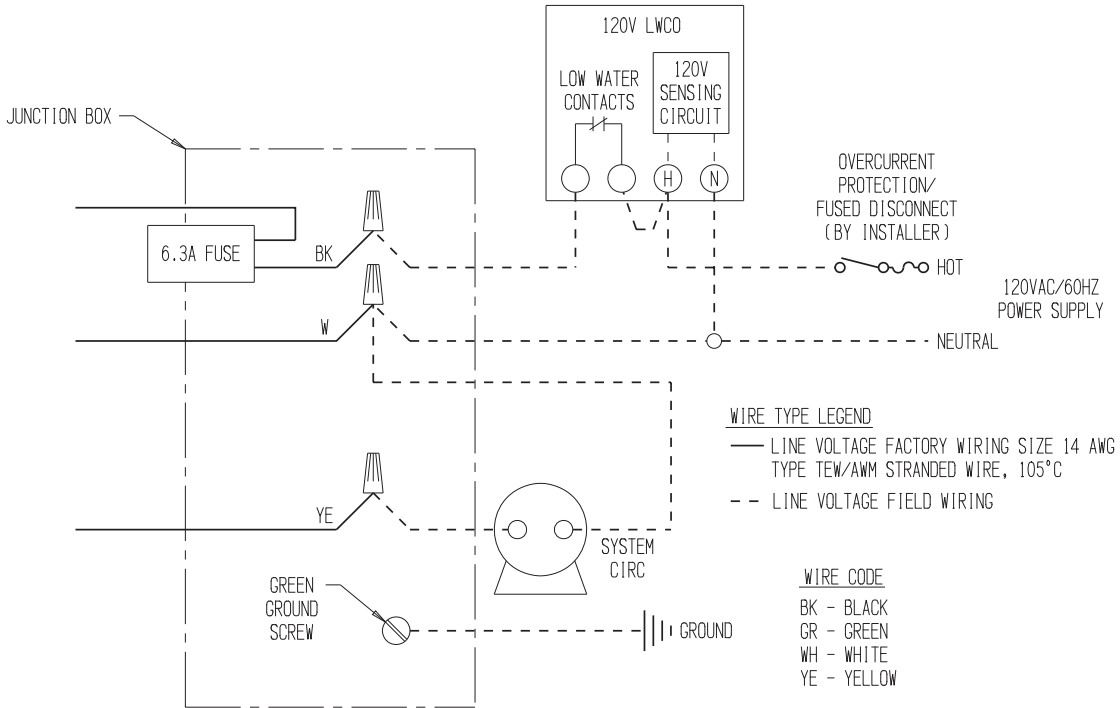
## XI. Wiring (continued)

- c. Low water cut-off wiring – Although not necessary to protect this boiler (see Part IX), some jurisdictions may insist that a low water cut-off (LWCO) be installed with this boiler. There are two ways to wire a LWCO into this boiler:
- A 120V LWCO may be wired to break 120V power to the boiler (Figure 11.4a)
  - A 24V LWCO may be wired so that its contacts are wired to the external limit connections on the boiler. When this is done either:
    - A separate transformer must be supplied by the installer to power the LWCO's sensing circuit. This transformer must be completely isolated from the boiler wiring (Figure 11.4b).
    - OR
    - Power may be taken from EnviraCOM connections, if not otherwise in use (Figure 11.4c)
- d. 4-20 mA Energy Management System (EMS) - A 4-20 mA EMS may be wired to the Sage controller (Figure 11.5). Manufacturer part numbers for contacts (field supplied) required to install wire leads in JST housing are:
- SRSF-61T-250A (Recommended for size 16 AWG wire)
    - ASRSFSRSF16K51B (2" lead between contacts)
    - ASRSFSRSF16K152B (6" lead between contacts)
    - ASRSFSRSF16K305B (12" lead between contacts)
  - SRSF-21T-250A (Recommended for size 20 AWG wire)
    - ASRSFSRSF20K51B (2" lead between contacts)
    - ASRSFSRSF20K152B (6" lead between contacts)
    - ASRSFSRSF20K305B (12" lead between contacts)
3. Data Connections – Modbus and EnviraCOM connections are located in the green control connector shared with the display connections (Figure 11.6). These connections have the following uses:
- a. EnviraCOM - Used to connect EnviraCOM thermostat or other EnviraCOM device listed by the boiler manufacturer for use with this boiler.
  - b. MODBUS - Boiler-To-Boiler communication network is used for multiple boiler ("Lead-Lag") installations. Note that combi boilers may only be used as slaves in such a system.

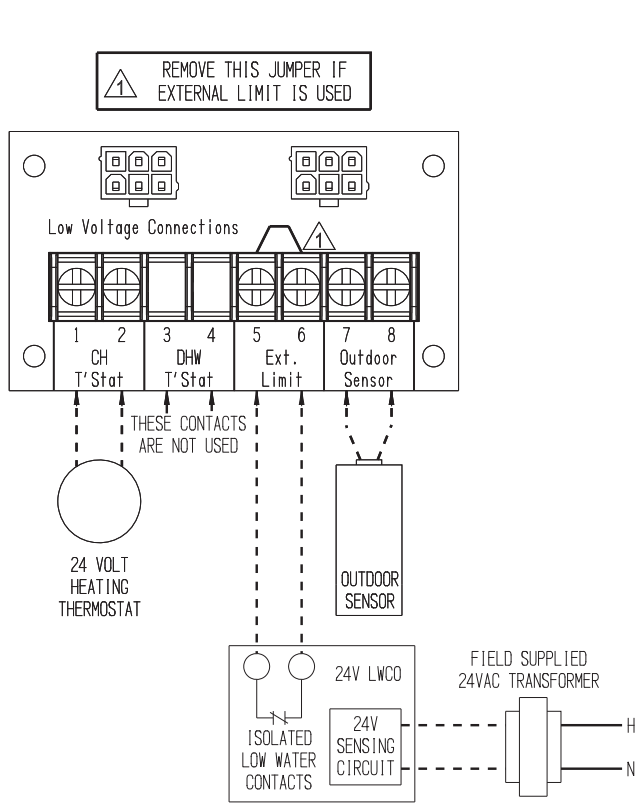
 **CAUTION** When making low voltage connections, make sure that no external power source is present in the thermostat or limit circuits. If such a power source is present, it could destroy the boiler's control. One example of an external power source that could be inadvertently connected to the low voltage connections is a transformer in the old thermostat wiring.

**Do not attempt to use EnviraCOM connections for any purpose not explicitly permitted by the boiler manufacturer. Attempting to do so may result in unreliable operation and/or damage to controls.**

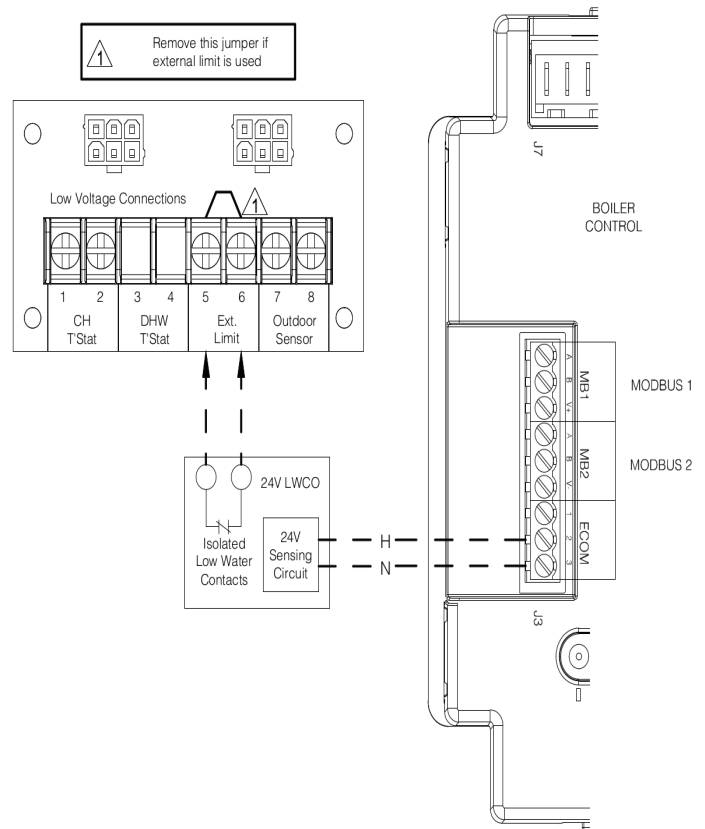
# XI. Wiring (continued)



**Figure 11.4a: 120 Volt LWCO Field Wiring**



**Figure 11.4b: 24 Volt LWCO Field Wiring Using 24 VAC Transformer**



**Figure 11.4c: 24 Volt LWCO Field Wiring Using Control ECOM**

## XI. Wiring (continued)

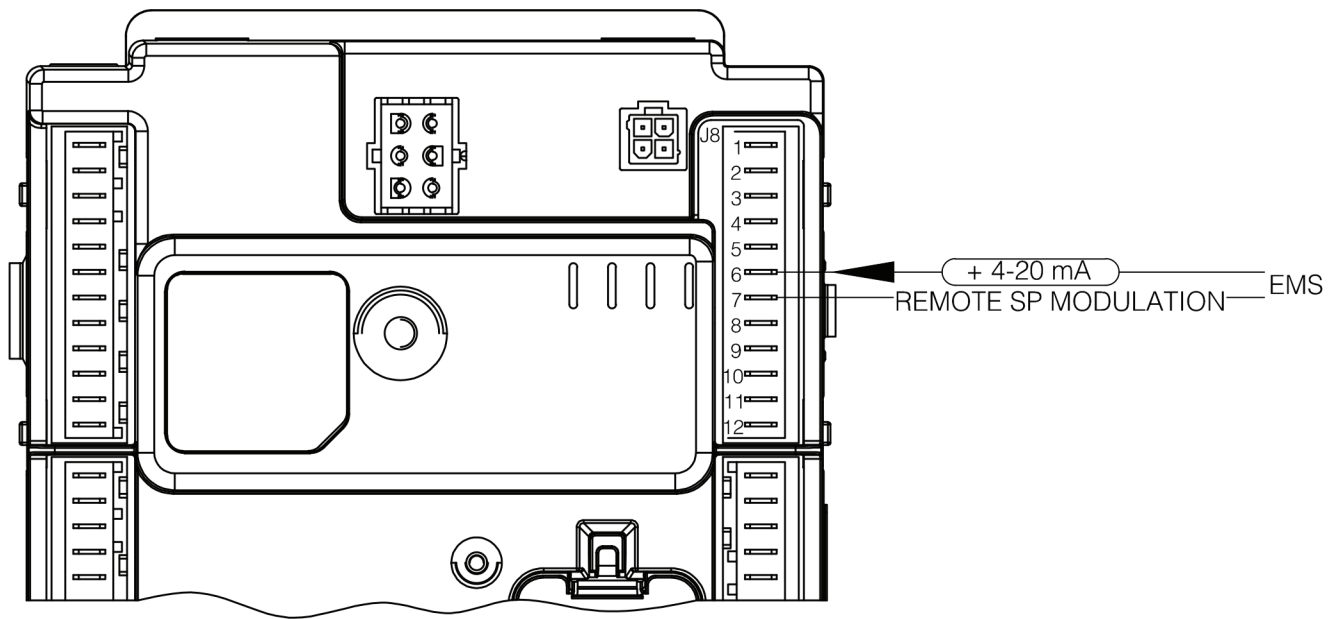


Figure 11.5: 4-20 mA EMS Field Wiring

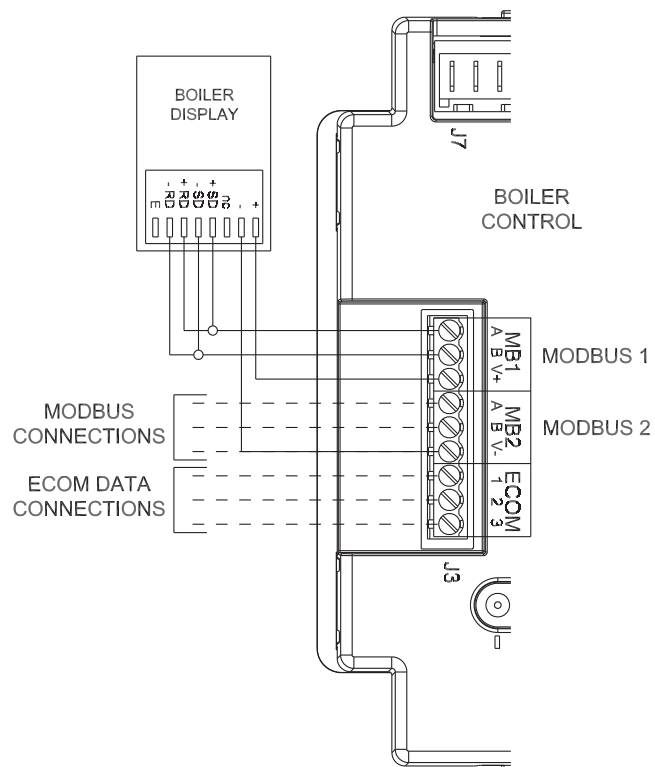
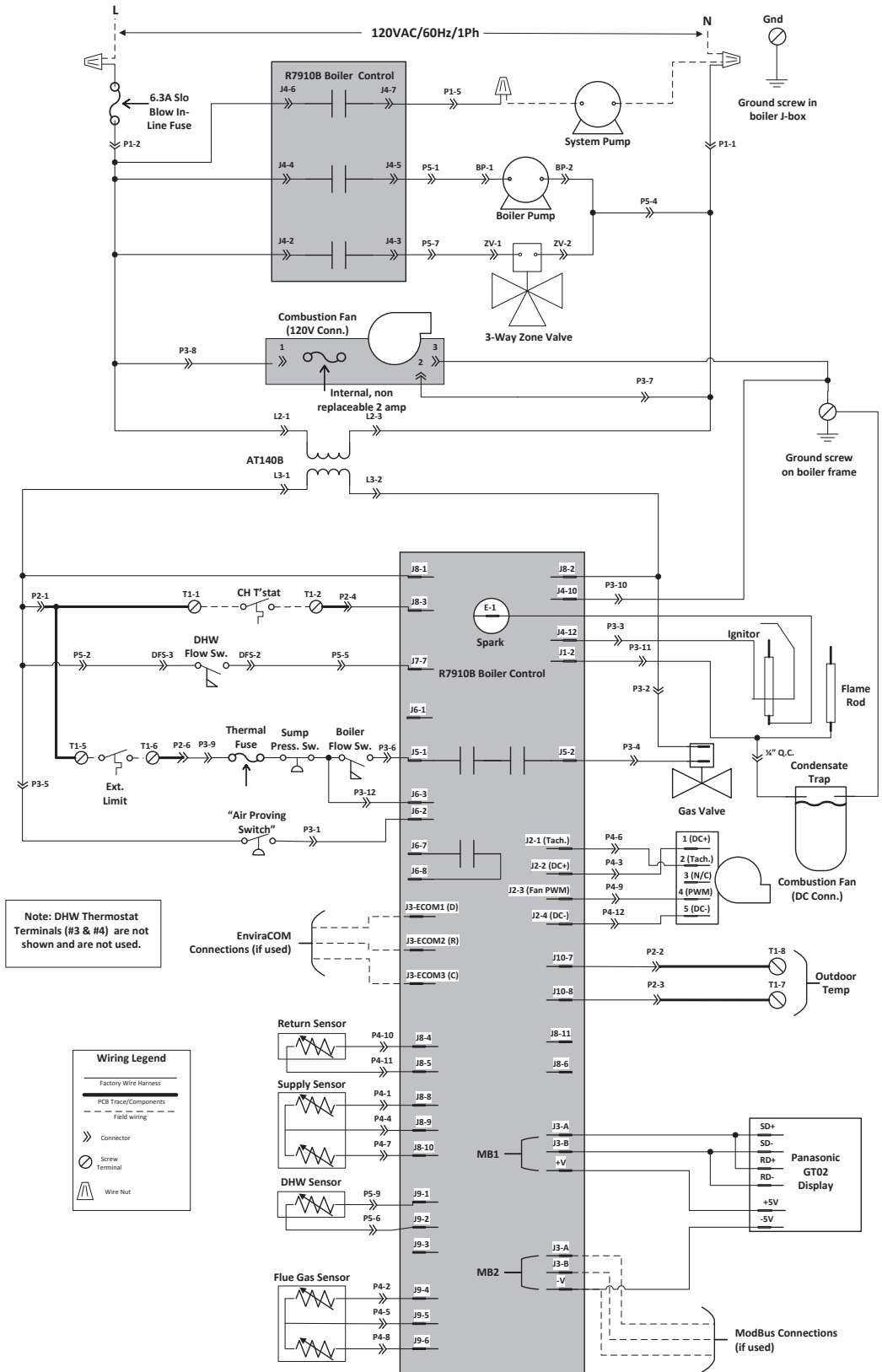


Figure 11.6: J3 Field Wiring

# XI. Wiring (continued)



Note: DHW Thermostat Terminals (#3 & #4) are not shown and are not used.

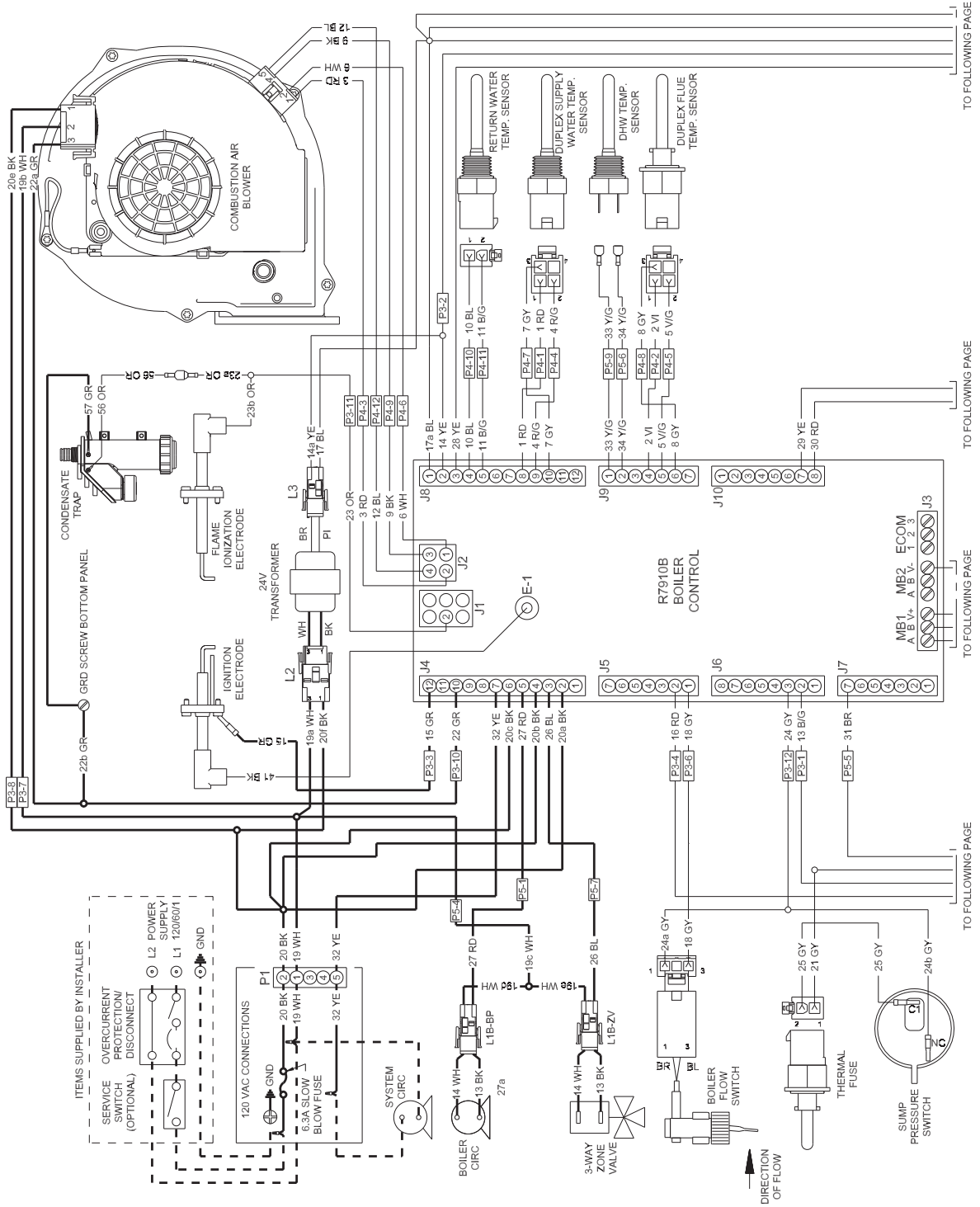
**Wiring Legend**

- Factory Wire Harness
- PCB Traces/Components
- Field wiring
- Connector
- Screw Terminal
- Wire Nut

Figure 11.7: Internal Ladder Diagram



# XI. Wiring (continued)



# XI. Wiring (continued)

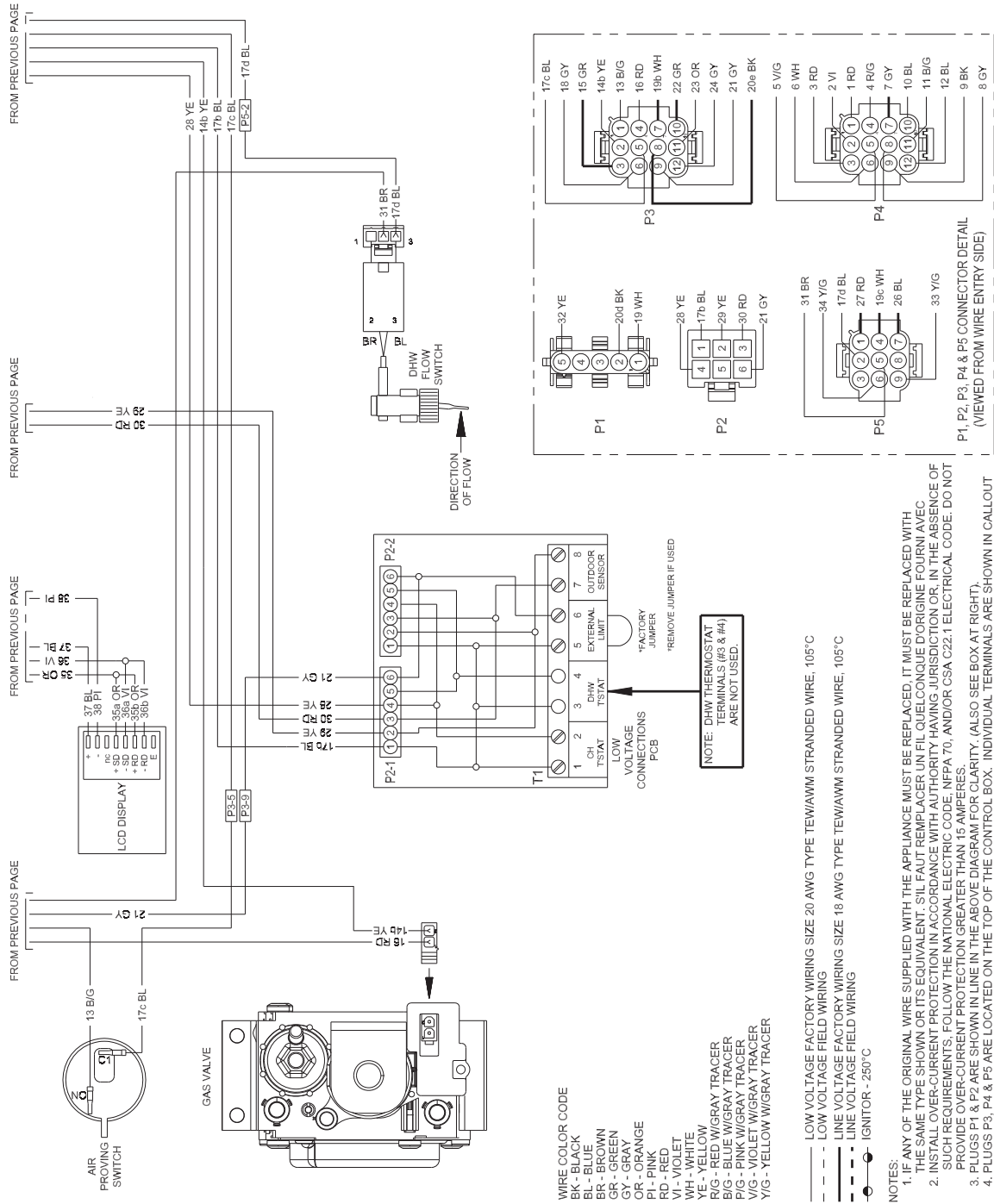


Figure 11.8: Internal Wiring Connections Diagram

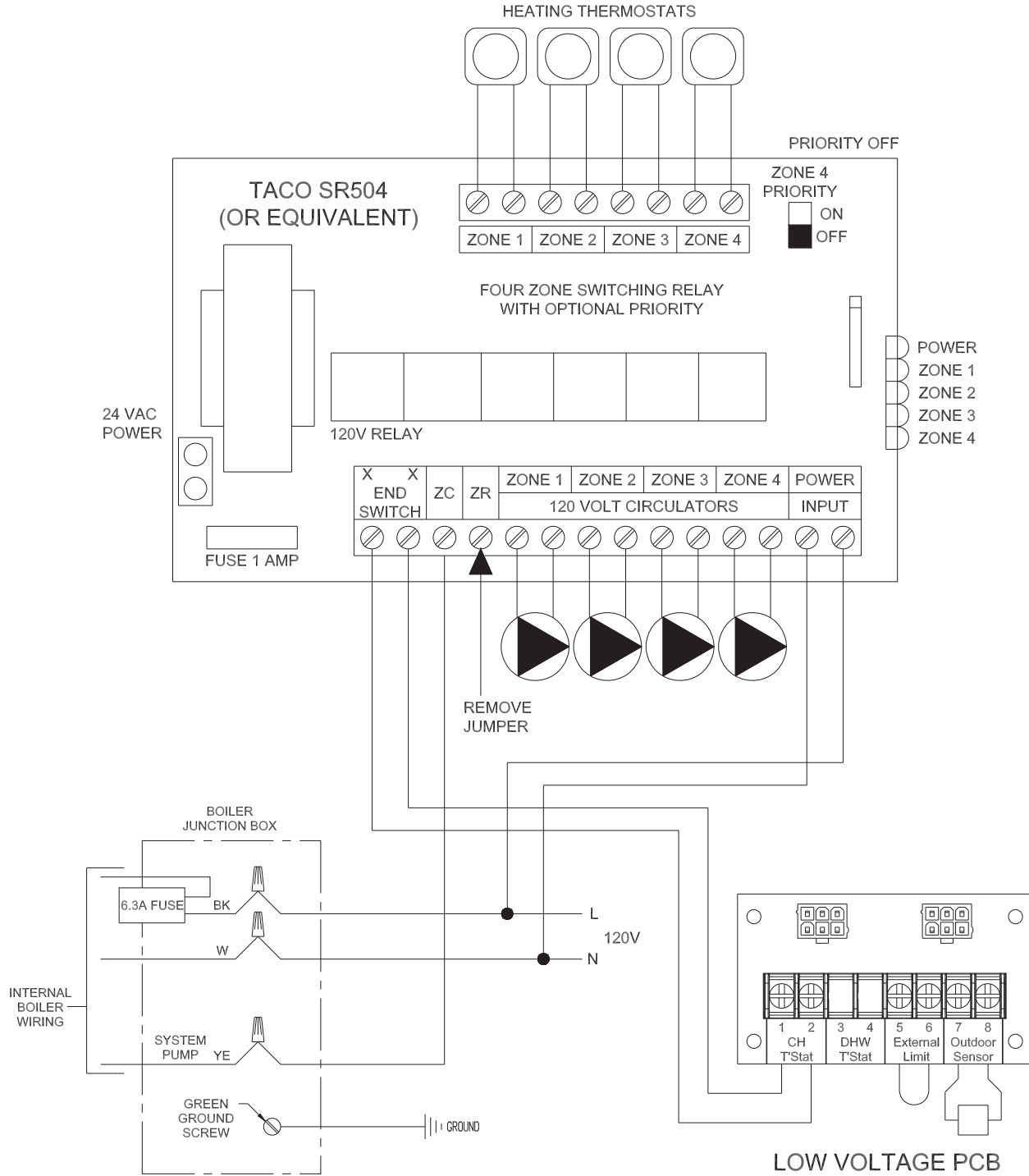
## XI. Wiring (continued)

**Table 11.8: Internal Wire Connection Markings Cross Reference Table**

WIRE NO. IN FIG. 11.8	WIRE MARKING	WIRE NO. IN FIG 11.8	WIRE MARKING
1 RD	J8-8/P4-1, P4-1/SUP-1	20 BK	SPL BK-1/P1-2, P1-2/120V
2 VI	J9-4/P4-2, P4-2/FLUE-1	20a BK	SPL BK-1/L2-1
3 RD	J2-2/P4-3, P4-3/FAN-1	20b BK	J4-2/SPL BK-1
4 R/G	J8-9/P4-4, P4-4/SUP-2	20c BK	J4-4/SPL BK-1
5 V/G	J9-5/P4-5, P4-5/FLUE-2	20d BK	J4-6/SPL BK-1
6 WH	J2-1/P4-6, P4-6/FAN-2	20e BK	SPL BK-1/P3-8, P3-8/B1-1
7 GY	J8-10/P4-7, P4-7/SUP-3	21 GY	P2-6/P3-9, P3-9/THERM-1
8 GY	J9-6/P4-8, P4-8/FLUE-3	22 GR	J4-10/P3-10, P3-10/SPL GR-1
9 BK	J2-3/P4-9, P4-9/FAN-4	22a GR	SPL GR-1/B1-3
10 BL	J8-4/P4-10, P4-10/RET-1	22b GR	SPL GR-1/GND
11 BL/G	J8-5/P4-11, P4-11/RET-2	23 OR	J1-2/P3-11, P3-11/SPL OR-1
12 BL	J2-4/P4-12, P4-12/FAN-5	23a OR	SPL OR-1/TRAP
13 BL/G	J6-2/P3-1, P3-1/APS	23b OR	SPL OR-1/FLAME
14 YE	L3-2/SPL Y-1	24 GY	J6-3/P3-12, P3-12/SPL GY-1
14a YE	J8-2/SPL Y-1	24a GY	SPL GY-1/FLOW-1
14b YE	SPL Y-1/P3-2, P3-2/GAS-2	24b GY	SPL GY-1/SPS
15 GR	J4-12/P3-3, P3-3/IGN GND	25 GY	SPS/THERM-2
16 RD	J5-2/P3-4, P3-4/GAS-1	26 BL	J4-3/P5-7, P5-7/ZV-1
17 BL	L3-1/SPL BL-1	27 RD	J4-5/P5-1, P5-1/BP-1
17a BL	SPL BL-1/J8-1	28 YE	J8-3/P2-4
17b BL	SPL BL-1/P2-1	29 YE	J10-7/P2-2
17c BL	SPL BL-1/P3-5, P3-5/APS	30 RD	J10-8/P2-3
17d BL	SPL BL-1/P5-2, P5-2/DFS-3	31 BR	J7-7/P5-5, P5-5/DFS-2
18 GY	J5-1/P3-6, P3-6/FLOW-3	32 YE	SYS PUMP/P1-5, P1-5/J4-7
19 WH	NEUT/ P1-1, P1-1/SPL W-1	33 Y/G	J9-1/P5-9, P5-9/DS
19a WH	SPL W-1/L2-3	34 Y/G	J9-2/P5-6, P5-6/DS
19b WH	SPL W-1/P3-7, P3-7/B1-2	35 OR	J3-1/SPL OR-1
19c WH	SPL W-1/P5-4, P5-4/SPL W-1	35a OR	SPL OR-1/ +RD
19d WH	P5-4/SPL W-1, SPL W-1/BP-2	35b OR	SPL OR-1/ +SD
19e WH	SPL W-1/ZV-2	36 VI	J3-2/SPL VI-1
		36a VI	SPL VI-1/ -RD
		36b VI	SPL VI-1/ -SD
		37 BL	J3-3/ 5V+
		38 PI	J3-6/ 5V-

USE WIRE CODE ON CONNECTIONS DIAGRAM TO DETERMINE COLOR.

# XI. Wiring (continued)



\*\*\*USE SAME POWER SOURCE FOR ALL CONTROLS AND ENSURE POLARITY TO ALL CONTROL DEVICES IS CORRECT

**Figure 11.9: TACO SR504 or Equivalent Zone Panel Wiring Connection Diagram**



---

## XII. Start-Up and Checkout

---

**WARNING**

Completely read, understand and follow all instructions in this manual before attempting start-up.

**NOTICE** Safe lighting and other performance criteria were met with the gas train assembly provided on the boiler when the boiler underwent the tests specified in Z21.13.

Use the following procedure for initial start-up of the boiler:

1. Verify that the venting, water piping, gas piping and electrical system are installed properly.
2. Confirm all electrical, water and gas supplies are turned off at the source and that vent is clear of obstructions.
3. Confirm that all manual shut-off gas valves between the boiler and gas source are closed.
4. If not already done, flush the system to remove sediment, flux, and traces of boiler additives.
5. Fill the boiler and hydronic system with water meeting the following requirements below (also see the note on the next page):
  - pH between 6.5 and 9.5
  - Hardness less than 7 grains/gallon
  - Chlorides less than 200 ppm
  - Pressurize the system to at least 12 psi at the boiler

**WARNING**

**Burn Hazard. The maximum operating pressure of this boiler is 30 psig (210 kPa) or 50 psig (340 kPa), depending on the model and safety relief valve option selected. Never exceed the maximum allowable working pressure on the heat exchanger ASME plate.**

6. Bleed air from the heat exchanger using the manual air vent in the top left side of the heat exchanger (Figure 12.1). To do this install a piece of 1/4" ID clear tubing over the hose barb and route the tubing to a location where water will not damage controls or nearby construction. Turn vent counter clockwise and allow heat exchanger to vent until a steady stream of water is observed. Close vent and remove hose.
7. Check all gas piping for leaks and purge piping sections that are filled with air. Refer to the National Fuel Gas Code for additional information on testing and purging gas lines.

**DANGER**

**Explosion Hazard. Do not use matches, candles, open flames or other ignition source to check for leaks.**

**Make sure that the area around the boiler is clear and free from combustible materials, gasoline and other flammable vapors and liquids.**

8. Confirm vent system is complete and free of obstructions before attempting to fire boiler.
9. Inspect all wiring for loose, uninsulated or miswired connections.
10. If the boiler is to be converted to propane, convert as described in conversion kit instructions. If boiler is operating at elevations above 2000ft, see Appendix A of this manual for setup instructions.

## XII. Start-Up and Checkout (continued)



**Asphyxiation Hazard.** Failure to properly convert this boiler for use on LP gas can cause unreliable operation at elevated carbon monoxide (CO) levels, resulting in personal injury or death.

**NOTICE** To minimize the risk of premature heat exchanger failure, observe the following water chemistry requirements:

1. Minimize the introduction of make-up water, dissolved oxygen, and contaminants into the boiler by following the installation guidelines shown in the “Water Quality and Boiler Water Additives Note” on Page 70.
2. Make sure the system is filled with water meeting the following criteria:
  - pH between 6.5 and 9.5 (for systems containing aluminum components, between 6.5 and 8.5)
  - Chloride level less than 200 PPM. If fill water is drawn from a system containing a water softener, test a sample of the fill water to confirm that this criteria is met.
  - Hardness less than 7 grains/gallon.
3. Avoid the use of petroleum based boiler additives and ester-based oils/lubricants. These can attack seals in both the boiler and system.
4. If freeze protection is required, use the following or its equivalent:
  - Fernox Alphi -11 (inhibited Propylene Glycol)
  - Sentinel® X500 Inhibited Propylene Glycol antifreeze (combined antifreeze and inhibitor)

Refer to the antifreeze manufacturer’s instructions for required dosage. In general these products are a blend of glycol (for freeze protection) and inhibitors (to protect the glycol from attacking metallic system components). Do not add any more antifreeze than is necessary to protect the system from freeze damage.

Many of these products require annual testing of the system water to ensure that the inhibitors are still active; consult the manufacturer’s instructions for maintenance requirements. Allowance must be made for the additional expansion of the glycol solution.

5. Test antifreeze and inhibitor concentration annually.
  - Inhibitor concentration test kit for Fernox Protector F1, 25 tests per kit. Part Number: 101148-01
  - Inhibitor, Fernox Protector F1, 1 pint (500 mL). Part Number: 101147-01
6. For system cleaning, use the following or its equivalent:
  - Fernox Cleaner F3
  - Sentinel® X300 System cleaner (for New Heating systems)
  - Sentinel® X 400 System Restorer (For old Closed Loop Hydronic Heating Systems)

Refer to the instructions supplied with the cleaner for proper dosage and use.

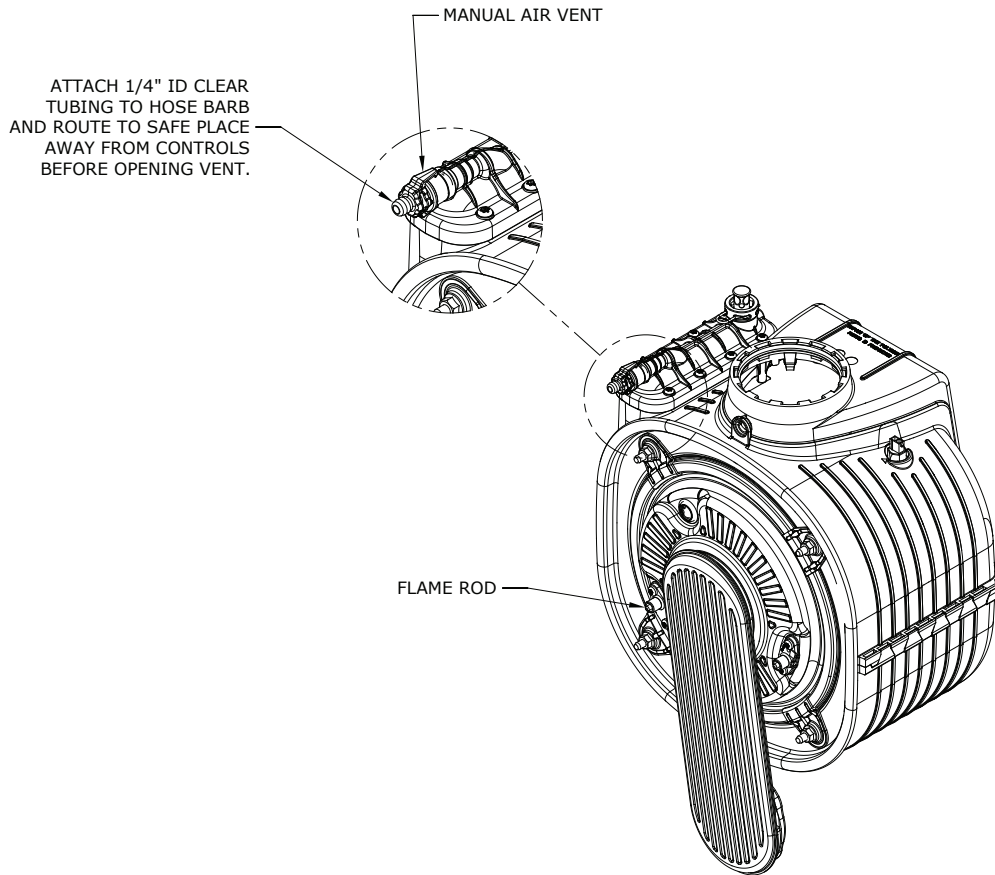
Fernox products are available from Alent PLC Consumer Products Division, 4100 6th Avenue, Altoona PA, (972) 547-6002 (fernox\_usa@alent.com)

Sentinel® Products are available from Douglas Products and Packaging, 1550 E. Old 210 Highway, Liberty, MO 64068, Tel: (877) 567-2560 (Toll Free) and /or selected HVAC distributors.



**Poison Hazard.** Use only inhibited propylene glycol solutions specifically formulated for hydronic systems. Do not use ethylene glycol, which is toxic and can attack gaskets and seals used in hydronic systems. Use of ethylene glycol could result in property damage, personal injury or death.

## XII. Start-Up and Checkout (continued)



**Figure 12.1: Location of Manual Air Vent**

11. Start the boiler using the lighting instructions on page 100. With the boiler powered up, and with no call for heat, the display should look like Figure 12.2a. Once a call for heat is present, it will look like Figure 12.2b.
12. The boiler should attempt to fire approximately 30 seconds after a call for heat appears. With the front door open, this try for ignition will appear as an audible spark (lasting approximately 4 seconds) and an audible click from the gas valve. Upon initial start-up, the gas train will be filled with air. Even if the gas line has been completely purged of air, it may take several tries for ignition before a flame is established. If the boiler does not light after six tries for ignition, it will enter a "soft lockout" and will wait for one hour before attempting another ignition sequence. This soft lockout can be reset by interrupting power to the boiler for a few seconds. Once a flame has been established for the first time, subsequent calls for burner operation should result in a flame on the first try.
13. If there is a problem that appears before the first try for ignition, or if the boiler fails to light after six tries for ignition, the blinking "HELP" button is highlighted on the Home screen (Figure 12.2c). Touching this "HELP" button will take the user to the Diagnostics menu where the cause of the problem can usually be found by pressing the flashing button on each successive screen.
14. Inspect the flame visible through the window. On high fire the flame should be stable and mostly blue (Figure 12.3). No yellow tipping should be present; however, intermittent flecks of yellow and orange in the flame are normal.
15. Check the inlet gas pressure. Verify that the inlet gas pressure is between the upper and lower limits shown on the rating plate with all gas appliances on and off.



## XII. Start-Up and Checkout (continued)

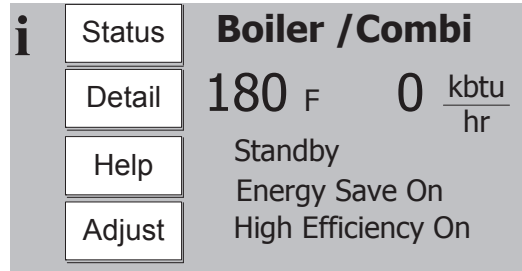


Figure 12.2a: Home Screen at Power-Up (No Call for Heat)

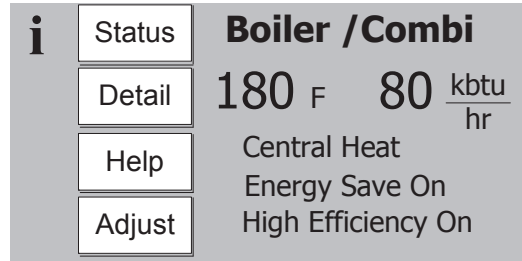


Figure 12.2b: Home Screen on Heat Demand

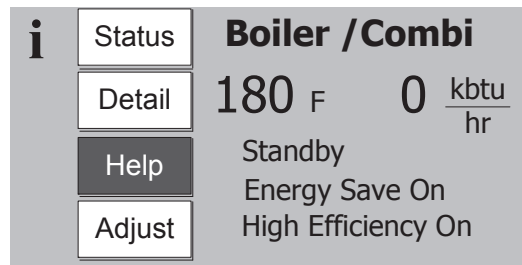


Figure 12.2c: Home Screen with Active Fault

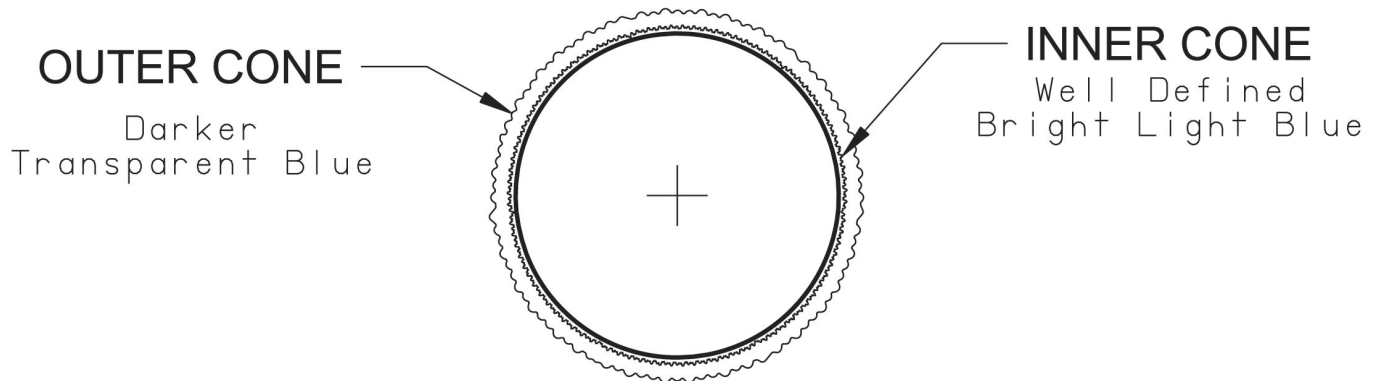


Figure 12.3: Burner Flame

## XII. Start-Up and Checkout (continued)

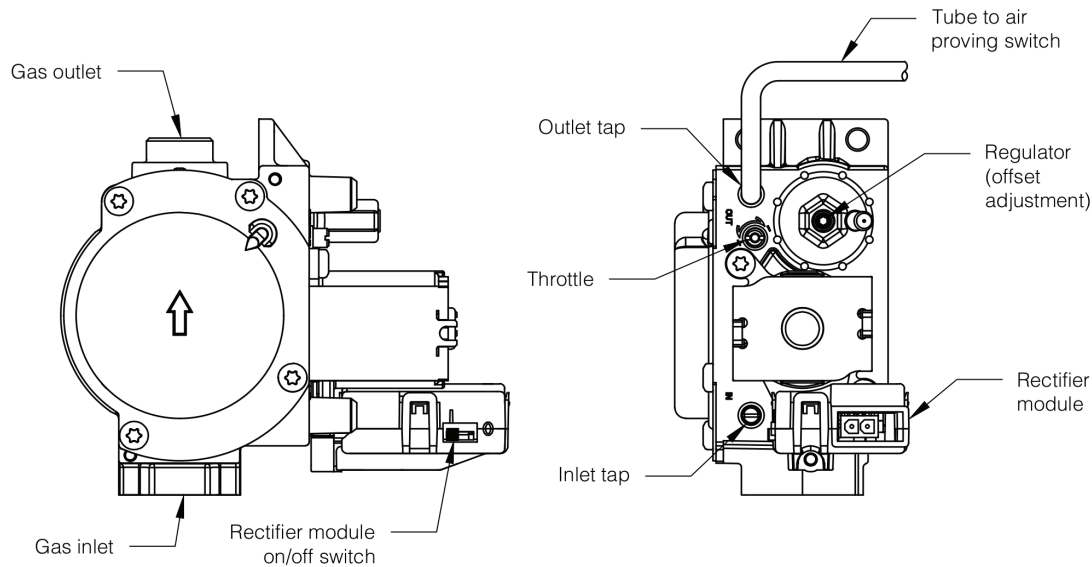


Figure 12.4: Gas Valve Detail





**WARNING** Do not attempt to operate this boiler on LP gas without converting it using the proper conversion kit.

**Do not attempt to convert this boiler to LP gas without the use of a combustion analyzer.**

**Failure to follow the conversion instructions will result in operation of the boiler at unsafe Carbon Monoxide (CO) levels and may result in personal injury or loss of life. Improper conversion may also result in unreliable operation, resulting in property damage.**

**Before attempting to operate this boiler at altitudes above 2000 ft., follow instructions shown in Appendix A of this manual.**

16. Perform a combustion test. Boilers are equipped with a screw cap in the vent adapter. Be sure to replace this cap when combustion testing is complete. Check CO<sub>2</sub> (or O<sub>2</sub>) and CO at both high and low fire. Ensure the door panel is sealed before combustion readings are taken. The boiler may be temporarily locked into high or low fire as follows:
  - a. Fire the boiler through any call for heat.
  - b. From the Home Screen, press "ADJUST" to enter the adjust menu.
  - c. Press "ADJUST".
  - d. Press "LOGIN".
  - e. Press "000".
  - f. Enter the password "086".
  - g. Press return arrow  to close the keypad.
  - h. Press "SAVE".
  - i. Press "ADJUST". 
  - j. Press "MANUAL CONTROL".
  - k. Press "HIGH" or "LOW" as appropriate.

## XII. Start-Up and Checkout (continued)

To return the boiler to automatic modulation, press AUTO FIRE. Note: If the Auto Fire button is not pressed, boiler will remain in manual fire for around 10 minutes. After 10 minutes boiler automatically returns to automatic modulation.

At both high and low fire, CO readings should be less than 200 PPM air free. Typical CO<sub>2</sub> and O<sub>2</sub> readings are shown in Table 12.5A. Final readings should be taken with all doors and covers in place. If adjustments are needed, make them as follows:

- a. With burner at high fire, adjust gas valve throttle (Fig 12.4) as needed to obtain CO<sub>2</sub> (or O<sub>2</sub>) setting shown in Table 12.5A.
  - To reduce the CO<sub>2</sub> (increase the O<sub>2</sub>), turn throttle clockwise.
  - To increase the CO<sub>2</sub> (reduce the O<sub>2</sub>), turn throttle counter-clockwise.

Make adjustments in increments of 1/8 to 1/4 turns and allow the boiler at least a minute to respond before making another adjustment.

- b. With the burner at low fire, adjust gas valve offset regulator (Fig 12.4) as needed to obtain CO<sub>2</sub> (or O<sub>2</sub>) setting shown in Table 12.5A.
  - To reduce the CO<sub>2</sub> (increase the O<sub>2</sub>), turn offset regulator counter-clockwise.
  - To increase the CO<sub>2</sub> (reduce the O<sub>2</sub>), turn offset regulator clockwise.

Make adjustments in increments of no more than 1/8 turns and allow the boiler at least a minute to respond before making another adjustment.



**WARNING** Improper gas valve adjustments can result in unreliable operation, substantial property damage, personal injury or loss of life due to carbon monoxide (CO) poisoning. Observe the following precautions:

- **Do not attempt to adjust gas valve without a combustion analyzer.**
  - **Each boiler is tested at the factory and adjustments to the gas valve are normally not necessary when operating on natural gas at sea level. Before making any adjustments, make sure that the analyzer is calibrated and that combustion readings have stabilized.**
  - **Regulator (“offset”) screw used for low fire adjustment is very sensitive. Adjust no more than 1/8 turn before checking combustion with analyzer. Maximum total regulator adjustment is ± 1 turn from factory setting.**
17. Perform a check of the ignition safety shut-off device. With the burner firing, carefully unplug the orange flame rod wire at the flame rod using a pair of insulated pliers (Figure 12.1). The burner should shut off immediately.
  18. Test any external limits or other controls in accordance with the manufacturer's instructions.
  19. Refer to the Operation Manual to set-up the control for the system in which the boiler is installed. Some common set-up tasks include:
    - Setting the CH temperature set-point.
    - Defining the system pump operation.
  20. Adjust the heating thermostat to its final set point.

## XII. Start-Up and Checkout (continued)

**NOTICE** In some cases, such as when the gas valve is replaced, the throttle may be far enough out of adjustment that it is not possible to fire the boiler while “dialing in” the CO<sub>2</sub> (or O<sub>2</sub>) using a combustion analyzer. In such a case, do the following:

1. Turn the throttle screw clockwise until it stops turning.
2. For natural gas applications, turn the throttle screw counter-clockwise by the number of turns shown in Figure 12.5B.
3. For LP gas applications set the preliminary throttle setting per conversion kit instructions.
4. Start the boiler using the lighting instructions on Page 100.
5. Once the boiler is firing, use a combustion analyzer to adjust the CO<sub>2</sub> (or O<sub>2</sub>) to its final value as described above.

**Table 12.5A: Typical Natural Gas Combustion Readings (Sea Level Only)**

Boiler Size	Measured High Fire %CO <sub>2</sub> *		Maximum CO Air-Free
	Range	Target	
135	8.7-9.2	9.1	200ppm
150			
180			

\* Low Fire Range and Target values are the same as High Fire above. Ensure low fire CO<sub>2</sub> reading is less than or equal to high fire CO<sub>2</sub> reading.

Boiler Size	Measured High Fire %O <sub>2</sub> **		Maximum CO Air-Free
	Range	Target	
135	4.7-5.6	4.9	200ppm
150			
180			

\*\* Low Fire Range and Target values are the same as High Fire above. Ensure low fire O<sub>2</sub> reading is greater than or equal to high fire O<sub>2</sub> reading.

**Table 12.5B: Starting Number of Throttle Turns for Natural Gas**

Model	# Counter-clockwise Turns (From Fully Closed)
135	12-1/4
150	10
180	15

**NOTICE** This boiler has a limited warranty, a copy of which is included with this boiler. It is the responsibility of the installing contractor to see that all controls are correctly installed and are operating properly when the installation is complete.

## XII. Start-Up and Checkout (continued)

### Lighting and Operating Instructions

#### FOR YOUR SAFETY READ BEFORE OPERATING/POUR VOTRE SECURITE LISEZ AVANT DE METTRE EN MARCHÉ

**WARNING:** If you do not follow these instructions exactly, a fire or explosion may result causing property damage, personal injury or loss of life.

**AVERTISSEMENT:** *Quiconque ne respecte pas à la lettre les instructions dans la présente notice risque de déclencher un incendie ou une explosion entraînant des dommages, des blessures ou la mort.*

- A. This appliance does not have a pilot. It is equipped with an ignition device which automatically lights the burner. Do not try to light the burner by hand.
- B. BEFORE OPERATING smell all around the appliance area for gas. Be sure to smell next to the floor because some gas is heavier than air and will settle on the floor.

#### WHAT TO DO IF YOU SMELL GAS:

- Do not try to light any appliance.
  - Do not touch any electric switch; do not use any phone in your building.
  - Immediately call your gas supplier from a neighbor's phone. Follow the gas supplier's instructions.
  - If you cannot reach your gas supplier, call the fire department.
- C. Use only your hand to turn the gas control knob. Never use tools. If the knob will not turn by hand, don't try to repair it, call a qualified service technician. Force or attempted repair may result in a fire or explosion.
- D. Do not use this appliance if any part has been under water. Immediately call a qualified service technician to inspect the appliance and to replace any part of the control system and any gas control which has been under water.

- A. Cet appareil ne comporte pas de veilleuse. Il est muni d'un dispositif d'allumage qui allume automatiquement le brûleur. Ne tentez pas d'allumer le brûleur manuellement.
- B. AVANT DE FAIRE FONCTIONNER, reniflez tout autour de l'appareil pour déceler une odeur de gaz. Reniflez près du plancher, car certains gaz sont plus lourds que l'air et peuvent s'accumuler au niveau du sol.

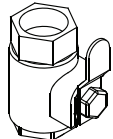
#### QUE FAIRE SI VOUS SENTEZ UNE ODEUR DE GAZ:

- Ne pas tenter d'allumer d'appareil.
  - Ne touchez à aucun interrupteur ; ne pas vous servir des téléphones se trouvant dans le bâtiment.
  - Appelez immédiatement votre fournisseur de gaz depuis un voisin. Suivez les instructions du fournisseur.
  - Si vous ne pouvez rejoindre le fournisseur, appelez le service des incendies.
- C. Ne poussez ou tournez la manette d'admission du gaz qu'à la main ; ne jamais utiliser d'outil. Si la manette reste coincée, ne pas tenter de la réparer ; appelez un technicien qualifié. Le fait de forcer la manette ou de la réparer peut déclencher une explosion ou un incendie.
- D. N'utilisez pas cet appareil s'il a été plongé dans l'eau, même partiellement. Faites inspecter l'appareil par un technicien qualifié et remplacez toute partie du système de contrôle et toute commande qui ont été plongés dans l'eau.

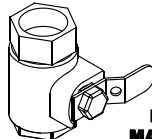
#### OPERATING INSTRUCTIONS/ INSTRUCTIONS DE FONCTIONNEMENT

1. STOP! Read safety information above on this label.
2. Set the thermostat to lowest setting.
3. Turn off all electric power to the appliance.
4. This appliance is equipped with an ignition device which automatically lights the burner. Do not try to light the burner by hand.
5. Turn the external boiler manual gas valve handle clockwise ↻ to close the gas supply.
6. Wait five (5) minutes to clear out any gas. Then smell for gas, including near the floor. If you smell gas, STOP! Follow "B" in the safety information above on this label. If you don't smell gas, go to the next step.
7. Turn the external boiler manual gas valve handle counterclockwise ↺ to open the gas supply.
8. Turn on all electric power to the appliance.
9. Set the thermostat to the desired setting.
10. If the appliance will not operate, follow the instructions "To Turn Off Gas To Appliance" and call your service technician or gas supplier.

OPEN/OUVERT



CLOSED/FERMÉ



EXTERNAL BOILER  
MANUAL GAS VALVE  
LA CHAUDIÈRE EXTERNE  
MANUELLE DE CLAPET À GAZ

1. ARRÊTEZ ! Lisez les instructions de sécurité sur la portion supérieure cette étiquette.
2. Réglez le thermostat à la température la plus basse.
3. Coupez l'alimentation électrique de l'appareil.
4. Cet appareil est équipé de l' dispositif d'allumage qui allume manuellement le brûleur. Ne tentez pas d'allumer le brûleur manuellement.
5. Tourner la chaudière externe manuelle poignée ↻ en clapet à gaz dans le sens des aiguilles d'une montre pour fermer l'offre de gaz.
6. Attendre cinq (5) minutes pour laisser échapper tout le gaz. Reniflez tout autour de l'appareil, y compris près du plancher, pour déceler une odeur de gaz. Si vous sentez une odeur de gaz, ARRÊTEZ ! Passez à l'étape B des instructions de sécurité sur la portion supérieure de cette étiquette. S'il n'y a pas d'odeur de gaz, passez à l'étape suivante.
7. Tourner la chaudière externe manuelle compteur de poignée ↺ en clapet à gaz ouvrir dans le sens des aiguilles d'une montre le gaz approvisionnement.
8. Mettez l'appareil sous tension.
9. Réglez le thermostat à la température désirée.
10. Si l'appareil ne se met pas en marche, suivez les instructions intitulées « Comment couper l'admission de gaz de l'appareil » et appelez un technicien qualifié ou le fournisseur de gaz.

#### TO TURN OFF GAS TO APPLIANCE/ COMMENT COUPER L'ADMISSION DE GAZ DE L'APPAREIL

1. Set the thermostat to lowest setting.
2. Turn off all electric power to the appliance if service is to be performed.
3. Turn the external boiler manual gas valve handle clockwise ↻ to close gas supply.

1. Réglez le thermostat à la température la plus basse.
2. Coupez l'alimentation électrique de l'appareil s'il faut procéder à l'entretien.
3. Tourner la chaudière externe manuelle poignée ↻ en clapet à gaz dans le sens des aiguilles d'une montre pour fermer l'offre de gaz.

## XIII. Operation

### IMPORTANT

This boiler is equipped with a feature that saves energy by reducing the boiler water temperature as the heating load decreases. This feature is equipped with an override which is provided primarily to permit the use of an external energy management system that serves the same function. THIS OVERRIDE MUST NOT BE USED UNLESS AT LEAST ONE OF THE FOLLOWING CONDITIONS IS TRUE:

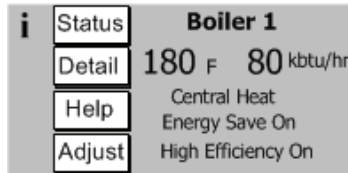
- An external energy management system is installed that reduces the boiler water temperature as the heating load decreases.
- This boiler is not used for any space heating.
- This boiler is part of a modular or multiple boiler system having a total input of 300,000 BTU/hr or greater.

### A. Overview

#### 1. Honeywell R7910B Controller

The Honeywell R7910B Controller (“Control”) contains features and capabilities which help improve heating system operation, and efficiency. By including unique capabilities, the Control can do more, with less field wiring, and fewer aftermarket controls and components—improving the operation of both new and replacement boiler installations.

#### 2. Advanced Touch Screen Display



#### Home Screen

Boiler status and setup selections are available from an easy to use LCD Touch Screen Display. In the event of a fault condition the user is guided by “blinking” touch buttons to Help screens that describe the problem. Operation evaluation and problem-solving is enhanced by historical capability including lockout history records as well as boiler and circulator cycle counts and run time hours.

#### 3. Advanced Modulating Control

The Control modulates the boiler input by varying the fan speed. As the fan speed increases, so does the amount of fuel gas drawn into the blower. As a result, a fairly constant air-fuel ratio is maintained across all inputs. The Control determines the input needed by looking at both current and recent differences between the measured temperature and the setpoint temperature. As the measured temperature approaches the setpoint temperature, the fan will

slow down and the input will drop. The Control also utilizes boiler return water and flue gas temperatures to adjust fan speed.

#### 4. HeatMatch™ Software

When the boiler is installed with a Sage Zone Control Panel (Zone Control) into a multiple zone home the Control uses a patent pending HeatMatch Software to improve home comfort, increase component life and save energy. The Control with the Zone Control detects active (turned “On”) zones, totals btu/hrs expected and limits the boiler firing rate to “match” actual home demand. Instead of simply firing to 100% in response to a cold supply water temperature the Control combines heat matching with supply water temperature control. Additionally, as zones turn “Off” maximum firing rate is immediately reduced eliminating the need for supply water temperature to first increase above setpoint. The result is longer run times, dramatic reduction in boiler excessive cycling and higher operating efficiency. Avoiding extra cycling saves customer fuel dollars (pre and post purge sends heat up stack) and saves wear and tear on the boiler. Lowering the boiler’s firing rate saves fuel dollars by increasing the amount of flue gas condensation, always the goal of condensing boiler installations.

#### 5. Built-in Safety Control

The Control includes safety controls designed to ensure safe and reliable operation. In addition to flame safety controls the Control includes supply water temperature, differential water temperature, and stack temperature safety limits and stepped modulation responses. Boiler modulation is adjusted when required to help avoid loss of boiler operation due to exceeding limits. Additionally, the Control accepts the field installation of optional auxiliary safety limits.



### XIII. Operation (continued)

#### 6. Outdoor Air Reset

When selected the modulation rate setpoint is automatically adjusted based on outside air temperature, time of day and length of demand (boost) settings. Outdoor air “reset” setpoint saves fuel by adjusting the water temperature of a heating boiler lower as the outside air temperature increases.

#### 7. Warm Weather Shutdown (WWSD)

Some boilers are used primarily for heating buildings, and the boilers can be automatically shutdown when the outdoor air temperature is warm. When outside air temperature is above the WWSD setpoint, this function will shut down the boiler, boiler and system pump.

#### 8. Energy Management System (EMS) Interface

A factory configured RS485 Modbus interface is available for Energy Management System (EMS) monitoring when not used for Multiple Boiler Sequencer Peer-To-Peer Network. Consult factory for points list or if this interface must be used in addition to the boiler Peer-to-Peer Network.

#### 9. Circulator Control

The control manages the operation of the built-in boiler pump, built in diverting valve, and installer supplied system pump (if used). The system pump may be configured to run or remain off when a call for domestic hot water is present (default is for the system pump to run). Circulators and diverting valve are automatically energized for a 20 second exercise period after not being used for longer than 7 days. Circulator exercise helps prevent pump rotor seizing.

#### 10. Multiple Boiler Sequencer Peer-To-Peer Network

The Control includes state-of-the-art modulating lead-lag sequencer for up to eight (8) boilers capable of auto rotation, outdoor reset and peer-to-peer communication. The peer-peer network is truly “plug and play”. This boiler may only be used as a slave in such a system. Consult the factory for additional information on using this boiler in multiple boiler systems.

### B. Water Temperature Regulation

#### 1. Priority Demand

The Control accepts a call for heat (demand) from multiple places and responds according to its “Priority”. When more than 1 demand is present the higher priority demand shown in Figure 13.1 is used to determine active boiler settings. Active “Priority” is displayed on the “Boiler Status” screen.

#### 2. Setpoint Purpose

The Control starts and stops the boiler and modulates the boiler input from minimum (MBH) to maximum (MBH) in order to heat water up to the active setpoint. The setpoint is determined by the priority (Central Heat or Domestic Hot Water) and as described in the following paragraphs.

#### 3. Central Heat Setpoint

Upon a Central Heat call for heat the setpoint is either the user entered Central Heat Setpoint, or is automatically adjusted by Outdoor Air Reset or, an Energy Management System (EMS) supplied setpoint.

**Table 13.1: Order of Priority**

Priority	Status Screen Display	Boiler Responding to:
1st	Domestic Hot Water	DHW call for heat is on and selected as the priority demand. DHW is higher priority than Central Heat during the DHW priority time. (default = 60 minutes)
2nd	Central Heat	Central Heat call for heat is on and there is no DHW demand or DHW priority time has expired.
3rd	Auxiliary Heat	Auxiliary Heat call for heat is on and there is no Central Heat or DHW demand. (NOTE: May be user selected to be higher priority than Central Heat.)
4th	Frost Protection	Frost Protection is active and there is no other call for heat.
5th	Warm Weather Shutdown (WWSD)	WWSD is active and the boiler will not respond to central heat demands. DHW demand is not blocked by WWSD.
6th	Standby	There is no demand detected.

#### 4. Auxiliary Heat Setpoint

Auxiliary Heat is a second heating demand that may be used to serve either lower temperature radiation or warmer heat demands such as fan coils. This demand may only be initiated via the Sage Zone Panel. Upon an Auxiliary Heat call for heat the setpoint is either the user entered Auxiliary Heat Setpoint or is automatically adjusted as Outdoor Air Reset.

## XIII. Operation (continued)

### 5. Outdoor Air Reset

If an outdoor temperature sensor is connected to the boiler and Outdoor Reset is enabled, the Central Heat setpoint will automatically adjust downwards as the outdoor temperature increases. When the water temperature is properly matched to heating needs there is minimal chance of room air temperature overshoot. Excessive heat is not sent to the room heating elements by “overheated” (supply water temperature maintained too high a setting) water. Reset control saves energy by reducing room over heating, reducing boiler temperature & increasing combustion efficiency and, reducing standby losses as a boiler and system piping cool down to ambient following room over heating.

### 6. Boost Time

When the Central Heat Setpoint is decreased by Outdoor Air Reset settings the Boost function can be enabled to increase the setpoint in the event that central heat demand is not satisfied for longer than the Boost Time minutes. The Boost feature increases the operating temperature setpoint by 10°F (5.6°C) every 20 minutes (field adjustable) the central heat demand is not satisfied. This process will continue until heat demand is satisfied (indoor air is at desired temperature), or the central heat setpoint is reached. Once the heat demand is satisfied, the operating setpoint reverts to the value determined by the Outdoor Air Reset settings. If Boost Time is zero, then the boost function is not used.

### 7. Domestic Hot Water (DHW) Setpoint

Upon a DHW call for heat the setpoint is the user entered DHW setpoint. When DHW has priority the boiler will modulate in an attempt to maintain the DHW set-point at the DHW sensor located near the hot water connection. The factory default for this setting is 120F.

### 8. Domestic Hot Water Priority (DHWP)

By default, when there is call for both CH and DHW, the DHW demand takes priority for the first 60 minutes of continuous simultaneous demand. This means that all boiler output will be directed to the DHW demand and the boiler will modulate as needed to maintain the temperature of the domestic hot water leaving the boiler at the DHW set-point. Also by default, during this time the system pump will circulate water through the system even though no heat is entering the system from the boiler (this behavior increases the odds that a “micro zone” demand can be satisfied using the heat in a buffer tank or elsewhere in the system).

At the end of the priority time, the boiler will divert its entire output to the CH demand and will revert to the CH set point as measured at the supply sensor. At this point all heating of DHW will end until there is an interruption in either the CH or DHW demand. The default 60 minute DHW priority time can be increased to as much as 120 minutes (see “Changing Adjustable Parameters”).

## C. Boiler Protection Features

### 1. Supply Water Temperature High Limit

The control is equipped with internal operating control and high limit features. The control monitors a dual element temperature sensor that is mounted in the supply water manifold and provides UL353 and UL1998 internal safety algorithms. If supply water temperature increases above the active setpoint plus diff above, default 190°F (87.7°C) the boiler is cycled off. If the temperature exceeds 210°F (98.9°C), a manual reset hard lockout results. If the boiler is responding to the internal Multiple Boiler Control Sequencer, or an External EMS demand and the supply water temperature increases above 190°F (87.7°C) the control begins to reduce the blower maximum speed setting and if the temperature increases to 200°F (93°C) a forced recycle results. Additionally, if the supply temperature rises faster than the degrees Fahrenheit per second limit a soft lockout is activated.

### 2. High Differential Temperature Limit

The Control monitors the temperature difference between the return and supply sensors. If this difference exceeds 52°F (29°C) the control begins to reduce the maximum blower speed. If temperature difference exceeds 62°F (34°C) a forced boiler recycle results. The unit will restart automatically once the temperature difference has decreased and the minimum off time has expired. If the temperature difference remains above 72°F (40°C) for longer than 3 minutes a manual reset hard lockout results.

### 3. Return Temperature Higher Than Supply Temperature (Inversion Limit)

The Control monitors the supply and return temperature sensors. If the return water temperature exceeds the supply water temperature for longer than a limit time delay the Control shuts down the boiler and delays restart. If the inverted temperature is detected more than five times, the boiler manual reset Hard Lockout is set. This condition is the result of incorrectly attaching the supply and return piping.



### XIII. Operation (continued)

#### 4. External Limit

An external limit control can be installed on the low voltage terminal strip. Be sure to remove the jumper when adding an external limit control to the system. If the external limit opens, the boiler will shut down and an open limit indication and error code are provided. If the limit installed is a manual reset type, it will need to be reset before the boiler will operate.

#### 5. Boiler Mounted Limit Devices

The control monitors individual limit devices: External Limit, Thermal Fuse, Sump Switch and Boiler Water Flow Switch. If any of these limits open the boiler will shut down and an open limit indication is provided. Additionally, the control monitors an air proving switch. During the boiler start sequence the control requires the air proving switch to be in the "open" position before the blower starts and in the "closed" position after the blower starts. If the air proving switch is not in the required position the start sequence is halted or the boiler is shut down and the open limit indication is provided. The air proving switch is only required to be closed during pre-purge. It is normal for the air proving switch to be open during run mode.

#### 6. Stack High Limit

The Control monitors the flue gas temperature sensor located in the vent connector. If the flue temperature exceeds 194°F (90°C), the control begins to reduce the maximum blower speed. If the flue temperature exceeds 204°F (96°C), a forced boiler recycle results. If the flue temperature exceeds 214°F (101°C), the control activates a manual reset Hard Lockout.

#### 7. Ignition Failure

The Control monitors ignition using a burner mounted flame sensor. In the event of an ignition failure, the control retries 5 times and then goes into soft lockout for one hour.

#### 8. Central Heating System Frost Protection

When enabled, Frost Protection starts the boiler and system pump and fires the boiler when low outside air and low supply water temperatures are sensed. The Control provides the following control action when frost protection is enabled:



**The Control helps provide freeze protection for the boiler water. Boiler flue gas condensate drain is not protected from freezing. Since the Control only controls the system and boiler circulators individual zones are not protected. It is recommended that the boiler be installed in a location that is not exposed to freezing temperatures.**

#### D. Multiple Boiler Control Sequencer

This boiler may be used as a slave in a multiple boiler system where the other boilers employ the same control. Consult factory for additional information on doing this.

**Table 13.2: Frost Protection**

Device Started	Start Temperatures	Stop Temperatures
Boiler Pump	Outside Air < 0°F (-18°C) Supply Water < 45°F (7.2°C)	Outside Air > 4°F (-16°C) Supply Water > 50°F (10°C)
Boiler	Supply Water < 38°F (3.3°C)	Supply Water > 50°F (10°C)

### XIII. Operation (continued)

#### E. Boiler Sequence of Operation

##### 1. Normal Operation

Table 13.3: Boiler Sequence of Operation

Status Screen Display	Description
<b>Boiler 1</b> ✕ Supply 140 F < Setpoint 140 F > Rate 0% ▼ Priority: Standby Status: Standby	Priority: Standby Status: Standby (burner <b>Off</b> , circulator(s) <b>Off</b> ) Boiler is not firing and there is no call for heat, priority equals standby. The boiler is ready to respond to a call for heat.
<b>Boiler 1</b> ✕ Supply 140 F < Setpoint 140 F > Rate 0% ▼ Priority: Central Heat Status: Standby	Priority: Central Heat Status: Standby (burner <b>Off</b> , circulator(s) <b>On</b> ) Boiler is not firing. There is a Central Heat call for heat and the Supply temperature is greater than setpoint minus the "Diff Below".
<b>Boiler 1</b> ✕ Supply 132 F < Setpoint 140 F > Rate 98% ▼ Priority: Central Heat Status: Prepurge 10	Priority: Central Heat Status: Prepurge When supply temperature drops burner demand continues with following Status shown: Safe Startup: Flame circuit is tested. Drive purge: The blower is driven to the fan purge speed. Prepurge: After the blower reaches the fan purge speed setting the combustion chamber purge is conducted.
<b>Boiler 1</b> ✕ Supply 132 F < Setpoint 140 F > Rate 89% ▼ Priority: Central Heat Status: Direct Ignition	Priority: Central Heat Status: Direct ignition After purge time is complete the following Status is shown: Drive light-off: The blower is driven to light-off rate. Pre-Ignition Test: After the blower reaches light-off rate a safety relay test is conducted. Pre-ignition: Spark is energized and it is confirmed that no flame is present Direct Ignition: Spark and Main fuel valve are energized.
<b>Boiler 1</b> ✕ Supply 132 F < Setpoint 140 F > Rate 100% Priority: Central Heat Status: Running	Priority: Central Heat Status: Running (burner <b>On</b> , circulator(s) <b>On</b> ) After flame is proven the sequence continues with run stabilization and low fire hold time. Once the field adjustable low fire hold time is completed normal boiler operation begins, modulation rate depending on temperature and setpoint selections.
<b>Boiler 1</b> ☒ DHW 119 F < Setpoint 120 F > Rate 50% Priority: Domestic Hot Water Status: Running	Priority: Domestic Hot Water Status: Running If the Central Heat call for heat is active and a Domestic Hot Water (DHW) call for heat received the DHW demand becomes the "priority" and the modulation rate, and setpoint, are based on DHW setting.
<b>Boiler 1</b> ✕ Supply 132 F < Setpoint 140 F > Rate 100% ▼ Priority: Standby Status: Postpurge 30	Priority: Standby Status: Post-purge (burner <b>Off</b> , circulator(s) <b>Off</b> ) If there is no call for heat the main fuel valve is closed and the blower is driven to the fan post-purge speed. After the blower reaches the fan post-purge speed setting, the combustion chamber purge is conducted.
<b>Boiler 1</b> ✕ Supply 132 F < Setpoint 140 F > Rate 100% ▼ Priority: Central Heat Status: Standby Delay	Priority: Standby Status: Standby Delay Standby delay status is entered when a delay is needed before allowing the burner control to be available. Select "Help" button from the "Home Screen" to determine the cause of the Standby Delay.
<b>Boiler 1</b> ✕ <b>Active Fault</b> Supply 132 F < Setpoint 140 F > Rate 100% ▼ Priority: Central Heat Status: Lockout	Priority: Standby Status: Lockout A lockout status is entered to prevent the boiler from running due to a detected problem. Select "Help" button from the "Home Screen" to determine the cause of the Lockout. The last 5 Lockouts are recorded in the Lockout History.

### XIII. Operation E. Boiler Sequence Of Operation (continued)

#### 2. Using The Display

The Control includes a touch screen LCD display. The user monitors and adjusts boiler operation by selecting screen navigation “buttons” and symbols. The “Home Screen” and menu selections are shown below. When no selection is made, while viewing any screen, the display reverts to the “Home Screen” after 4 minutes. The “Home Screen” provides boiler temperature, firing rate in BTU/hr, boiler status, efficiency information and page links.

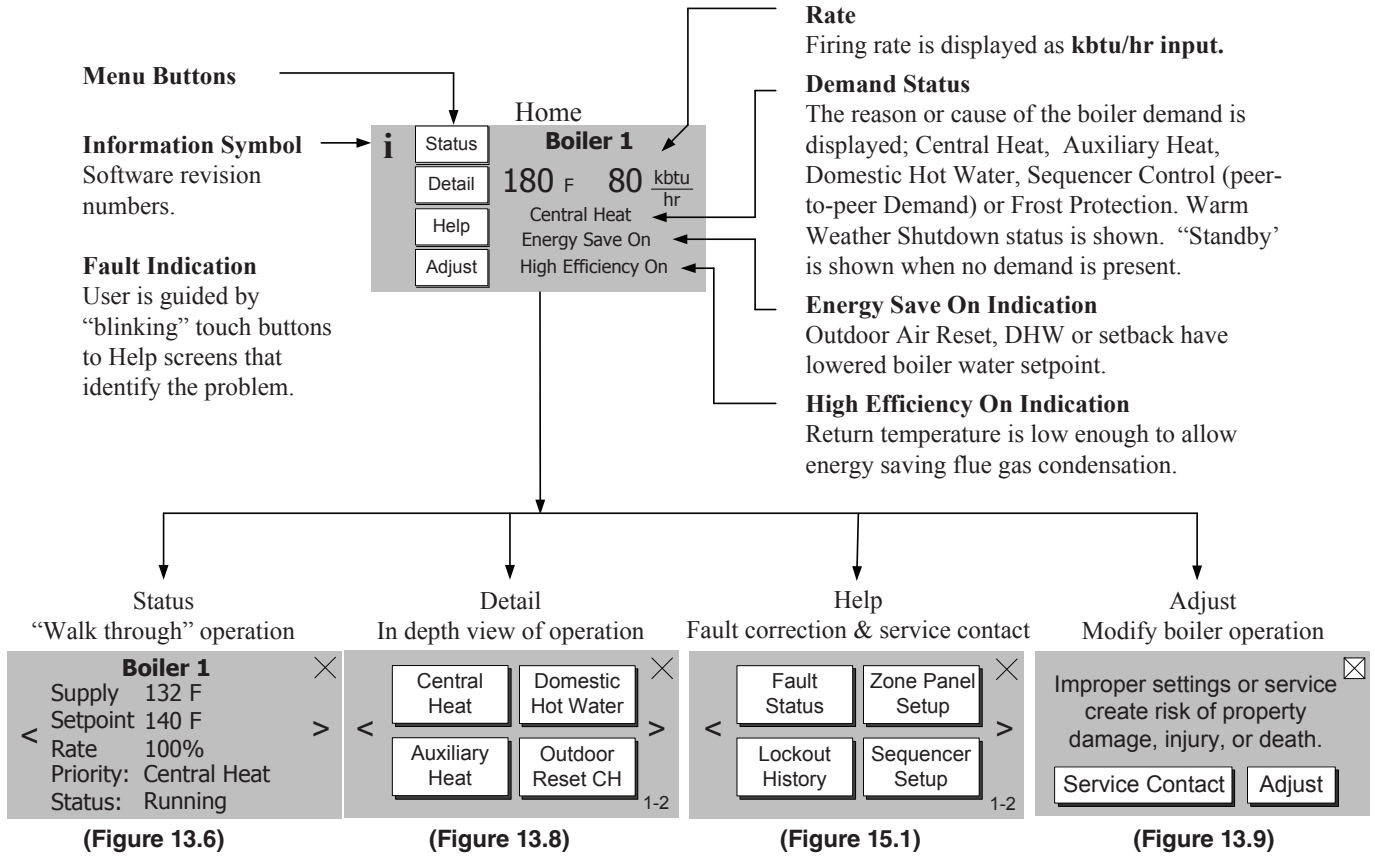


Figure 13.4: Home Screen Details

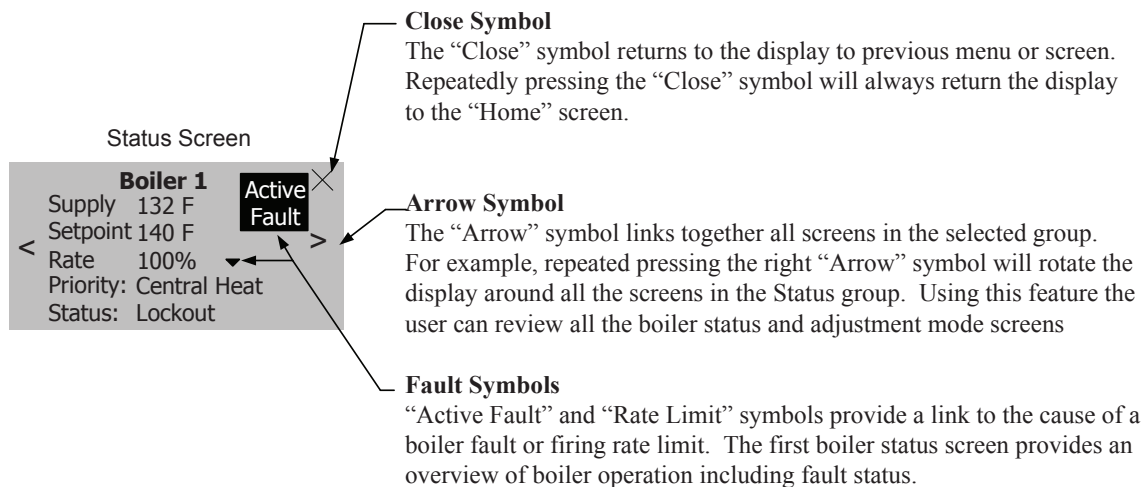


Figure 13.5: Screen Navigation

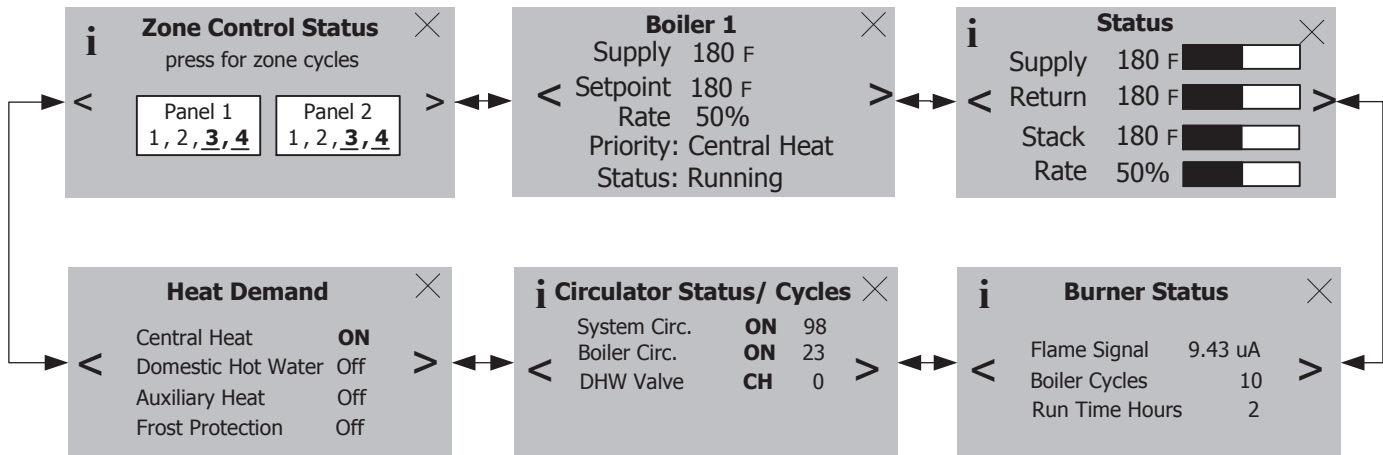
### XIII. Operation E. Boiler Sequence Of Operation (continued)

#### 3. Status Screens

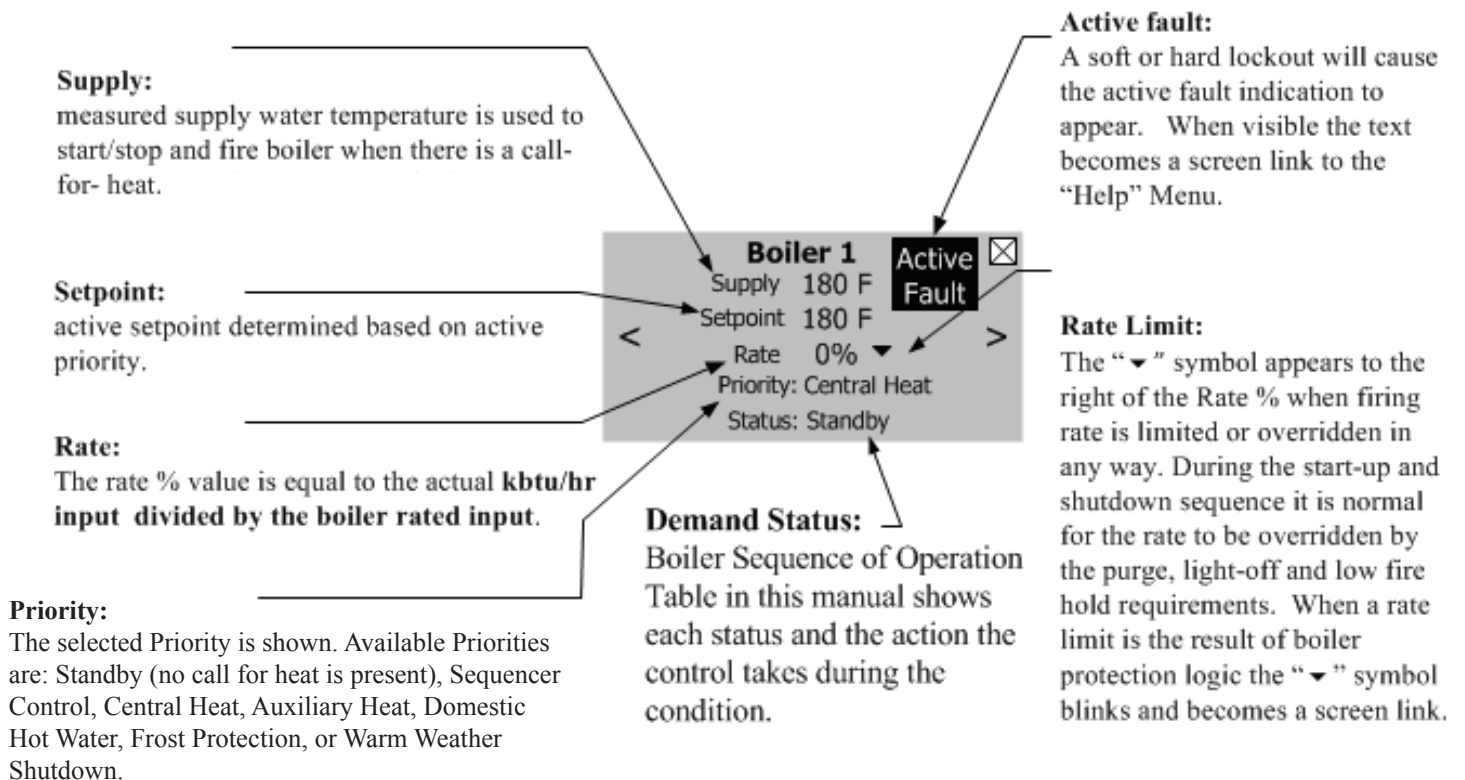
Boiler Status screens are the primary boiler monitoring screens. The user may simply “walk” through boiler operation by repeatedly selecting the right or left “arrow” symbol. These screens are accessed by selecting the “Status” button from the “Home” screen.

**NOTE**

Only visible if Sage Zone Panel is connected. Zone Panel 1 and 2 shown typical for 1 through 4.



**Figure 13.6: Status Screens**

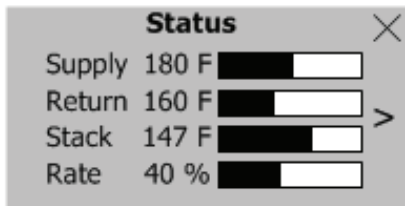


**Figure 13.7: Boiler Status Screen Definitions**

### XIII. Operation E. Boiler Sequence Of Operation (continued)

#### 3. Status Screens (continued)

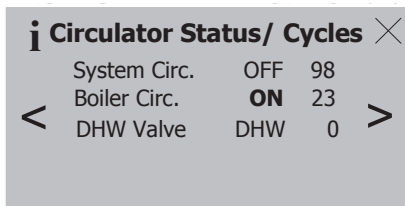
##### Bargraph Screen



##### Bargraph Screen

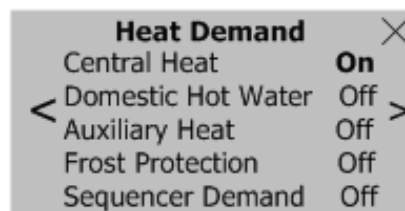
The bargraph screen presents measured values for easy comparison.

##### Circulator/Valve Status Screen



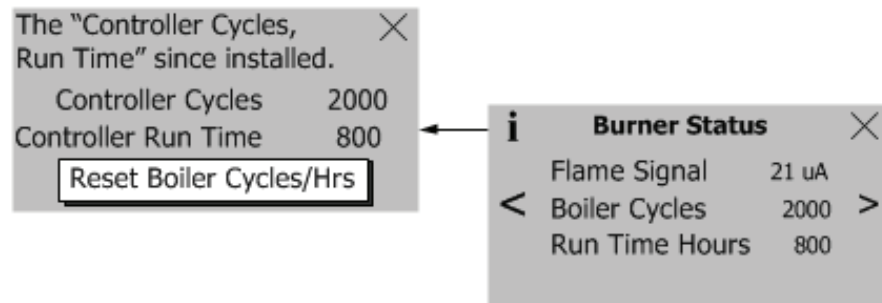
This screen provides the status of the boiler's internal diverting valve, internal pump and external system pump (if used). It also provides the status of Frost Protection and pump Exercise functions.

##### Heat Demand Screen



This screen provides the status of the boilers five (5) possible heat demands. When demand is off the Control has not detected the call-for-heat. This screen allows the user to determine which demands are present when more than one demand is present.

##### Burner Status Screen



##### Cycles and Hours

Boiler cycles and hours are used to monitor the boilers overall compatibility to the heating load. Excessive cycling compared to run time may be an indication of pumping, boiler sizing or adjustment issues.

##### NOTE

"Boiler Cycle" and "Run Time Hours" are resettable by selecting the reset "button" located on the information screen.

The "Controller Cycles" and "Controller Run Time" data is not resettable and remains for the life of the control.

### XIII. Operation E. Boiler Sequence Of Operation (continued)

#### 3. Status Screens (continued)

##### Zone Control Status Screens (only visible if Sage Zone Panel connected)

Active zones are shown by bold & underlined numbers. Press the zone panel to view zone cycle counts.

To reset all zone cycle counts press: Reset Cycle Counts

**Zone Control Status**

press for zone cycles

Panel 1  
1, 2, 3, 4

##### Zone Control Status

Screen provides status and a page links for up to four zone panels. Individual zone "on" status is shown by a bold zone number with a solid underscore. "Press" the zone control "button" to view individual zone cycles.

#### NOTE

Zone cycles are resettable by selecting the reset "button" located on the information screen.

**Zone Panel 1**

Demand	Cycles
KITCHEN	45
BEDROOMS	20
BASEMENT	12
DOMESTIC HOT WATER	26

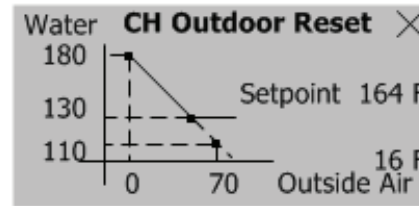
#### 4. Detail Screens

Detail screens are accessed by selecting the "Detail" button from the "Home" screen. These screens provide in depth operating parameter status such as "On Point", "Off Point" and "Setpoint Source" information. Demand-specific details are provided for Central Heat, Auxiliary Heat, Domestic Hot Water demands and outdoor air reset. Sequencer screens are only shown when the Sequence Master is enabled.

**Central Heat**

Off Point + 185  
Setpoint 180      Supply  
On Point - 173      180 F  
Firing Rate      22%  
Setpoint: Outdoor Reset

Demand Detail Display  
(Central Heat shown, Typical for Auxiliary Heat, Domestic Hot Water and Sequencer Master)



Outdoor Reset Display  
(Central Heat shown, Typical for Auxiliary Heat)

Figure 13.8: Detail Screen Overview



### XIII. Operation F. Changing Adjustable Parameters

#### F. Changing Adjustable Parameters

##### 1. Entering Adjust Mode

The Control is factory programmed to include basic modulating boiler functionality. These settings are password protected to discourage unauthorized or accidental changes to settings. User login is required to view or adjust these settings:

- Press the "Adjust" button on the "Home" screen.
- Press the "Adjust" button on the Adjust Mode screen or Press "Service Contact" for service provider contact information.
- Press "Login" button to access password screen.
- Press 5-digit display to open a keypad. Enter the password (Installer Password is 86) and press the return arrow to close the keypad. Press the "Save" button.
- Press the "Adjust" button to enter Adjustment mode.

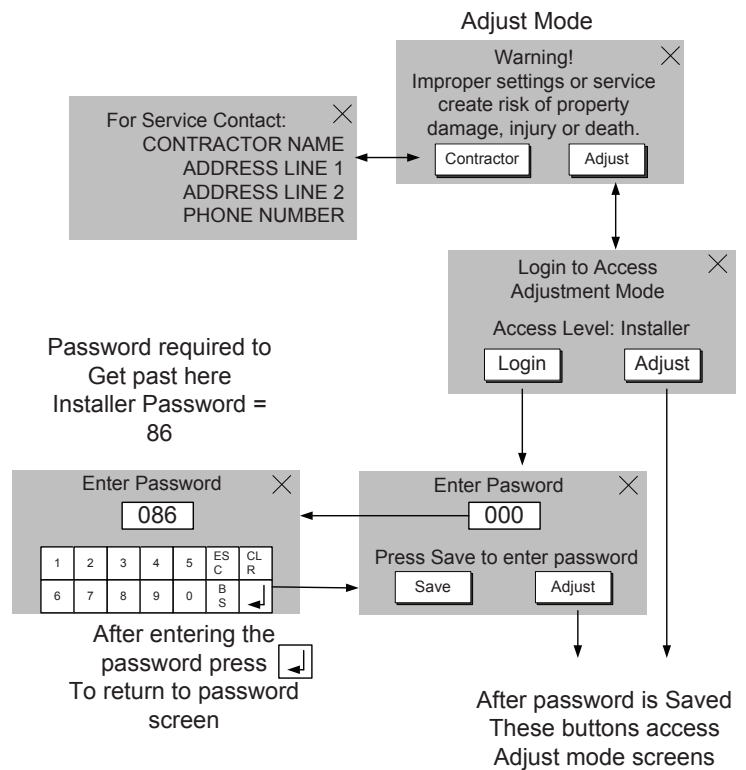
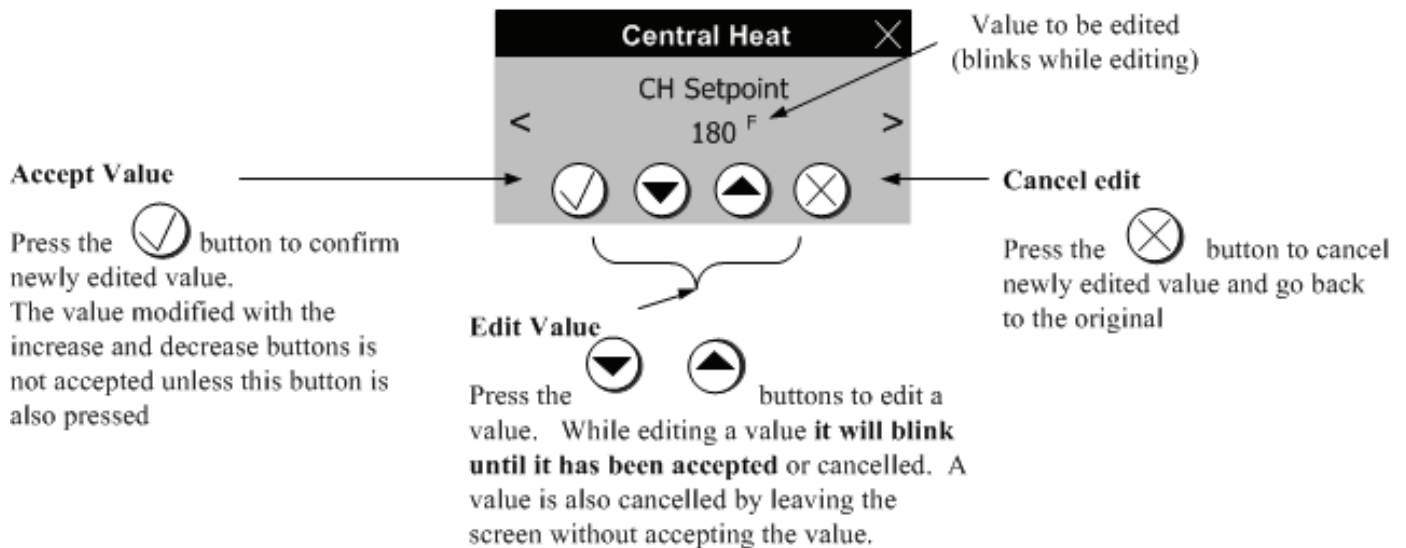


Figure 13.9: Adjust Mode Screens

##### 2. Adjusting Parameters

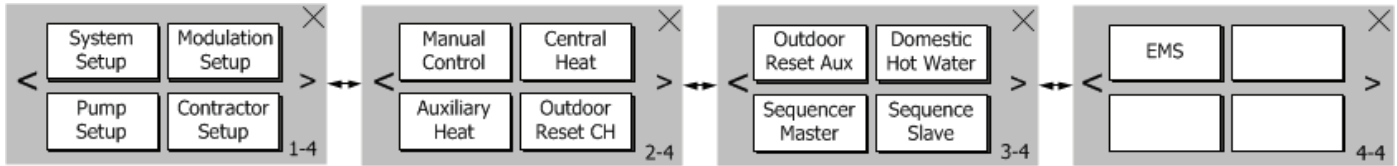
Editing parameters is accomplished as follows:



### XIII. Operation F. Changing Adjustable Parameters (continued)

#### 2. Adjusting Parameters (continued)

The following pages describe the Control's adjustable parameters. Parameters are presented in the order they appear on the Control's Display, from top to bottom and, left to right. From the "Home" screen select the Adjust button to access the adjustment mode screens show below (if required, refer to the previous page to review how to enter Adjustment mode):



"Press" System Setup button to access the following parameters:

Factory Setting	Range / Choices	Parameter and Description
Fahrenheit	Fahrenheit, Celsius	<b>Temperature Units</b> The Temperature Units parameter determines whether temperature is represented in units of Fahrenheit or Celsius degrees.
Wired	Not Installed, Wired, Wireless	<b>Outdoor Sensor Source</b> Not Installed Outdoor Sensor is not connected to the boiler, the sensor is not monitored for faults. Wired Outdoor Sensor is installed directly on the boiler terminal Strip. Wireless Outdoor sensor is installed and wireless.
Enabled	Enable/Disable	<b>Frost Protection</b> Disable Frost Protection is not used. Enable Boiler and system circulators start and boiler fires when low outside air, supply and return temperatures are sensed.
Disabled	Enable/Disable	<b>Warm Weather Shutdown Enable</b> Disable Warm Weather Shutdown (WWSD) is not used. Enable The boiler and pumps will not be allowed to start in response to a central heat call for heat if the outside temperature is greater than the WWSD setpoint. WWSD is initiated as soon as outside air temperature is above WWSD Setpoint. The control does not require call for heat to be satisfied. The boiler will still start in response to a Domestic Hot Water call for heat.
70°F	0-100°F	<b>Warm Weather Shutdown Setpoint</b> The Warm Weather Shutdown (WWSD) Setpoint used to shutdown the boiler when enabled by the "WWSD Enable" parameter.



### XIII. Operation F. Changing Adjustable Parameters (continued)

#### 2. Adjusting Parameters (continued)



**WARNING** Asphyxiation Hazard. Boiler type is factory set and must match the boiler model. Only change the boiler type setting if you are installing a new or replacement Control. The boiler type setting determines minimum and maximum blower speeds. Incorrect boiler type can cause hazardous burner conditions and improper operation that may result in PROPERTY LOSS, PHYSICAL INJURY OR DEATH.

“Press” Modulation Setup button to access the following parameters:

Factory Setting	Range / Choices	Parameter and Description
See Table 13.10	See Table 13.10	<p><b>Boiler Type</b> Boiler Size Setup To verify the boiler size selection, a qualified technician should do the following:</p> <ol style="list-style-type: none"> <li>1. Check boiler’s label for actual boiler size.</li> <li>2. Set “Boiler Type” to match actual boiler size.</li> <li>3. Select “Confirm”</li> </ol> <p>The Boiler Type parameter changes multiple, minimum and maximum modulation settings. This parameter is intended to allow a user to set the parameters in a spare part Control to a particular boiler type. When changing the “Boiler Type” be sure to select “ENTER” and “NEXT” until all parameters are entered as shown by the “complete” indication.</p>
100%	Minimum to Maximum Heat Rate	<p><b>Central Heat (CH) Maximum Heat Rate</b> This parameter defines the highest modulation rate the Control will go to during a central heat call for heat. If the rated input of the installed home radiation is less than the maximum output of the boiler, change the Central Heat Maximum Expected Heat Rate (fan speed) setting to limit the boiler output accordingly.</p>
100%	Minimum to Maximum Heat Rate	<p><b>Domestic Hot Water (DHW) Maximum Heat Rate</b> This parameter defines the highest modulation rate the Control will go to during a Domestic Hot Water call for heat. Adjustment generally not recommended.</p>
100%	Minimum to Maximum Heat Rate	<p><b>Auxiliary Maximum Heat Rate</b> This parameter defines the highest modulation rate the Control will go to during the auxiliary heat call for heat. If the rated input of the Auxiliary Heat Zones is less than the maximum output of the boiler, change the Auxiliary Heat Maximum Expected Heat Rate (fan speed) setting to limit the boiler output accordingly.</p>
100%	Minimum to Maximum Heat Rate	<p><b>DHW or BOTH DHW &amp; CH</b> Do not adjust</p>
40%	100 RPM to Maximum Heat Rate	<p><b>Zone 1 Expected Heat Rate (typical for zone 1 through 16)</b> This parameter defines the highest modulation rate the Control will go to during the Zone 1 call for heat. If the rated input of the installed home radiation in zone 1 is less than the maximum output of the boiler, change the Zone 1 Expected Heat Rate (fan speed) setting to limit the boiler output accordingly.</p>
15 Minutes	0 to 60 Minutes	<p><b>Zone Release Time</b> After the Zone Release Time minutes and a zone has not been satisfied (thermostat opens) the measured heat loss will be released to increase to the Central Heat Maximum Heat Rate.</p>
See Table 13.10	Minimum to Maximum	<p><b>Minimum Modulation</b> This parameter is the lowest modulation rate the Control will go to during any call for heat.</p>
See Table 13.10	3000 - 4500 RPM	<p><b>Lightoff Rate</b> This is the blower speed during ignition and flame stabilization periods.</p>

**XIII. Operation F. Changing Adjustable Parameters (continued)**

**Table 13.10: Parameters Changed Using the Boiler Type Parameter Selections:**

<b>Control Repair Part Kit #</b>	<b>107877-01</b>		
<b>Altitude</b>	<b>0-2000ft</b>		
<b>Model</b>	<b>K2WTC-135B-02-N</b>	<b>K2WTC-150B-02-N</b>	<b>K2WTC-180B-02-N</b>
Maximum Firing Rate, CH (RPM)	7300	7900	8100
Maximum Firing Rate, DHW (RPM)	8300	7900	8100
Minimum Firing Rate (RPM)	1700	1700	1600
Default Light-off Rate (RPM)	4000	4000	3000
<b>Model</b>	<b>K2WTC-133B-02-P</b>	<b>K2WTC-150B-02-P</b>	<b>K2WTC-180B-02-P</b>
Maximum Firing Rate, CH (RPM)	7300	7900	8100
Maximum Firing Rate, DHW (RPM)	8300	7900	8100
Minimum Firing Rate (RPM)	1700	1700	1600
Default Light-off Rate (RPM)	4000	4000	4000
<b>Altitude</b>	<b>2001-6000ft</b>		
<b>Model</b>	<b>K2WTC-135B-26-N</b>	<b>K2WTC-150B-26-N</b>	<b>Not Permitted on Either Fuel</b>
Maximum Firing Rate, CH/DHW (RPM)	8500	8700	
Minimum Firing Rate (RPM)	1800	1900	
Default Light-off Rate (RPM)	4000	4000	
<b>Model</b>	<b>K2WTC-135B-26-P</b>	<b>K2WTC-150B-26-P</b>	
Maximum Firing Rate, CH/DHW (RPM)	8500	8700	
Minimum Firing Rate (RPM)	1800	1900	
Default Light-off Rate (RPM)	4000	4000	
<b>Altitude</b>	<b>6001-7800ft</b>		
<b>Model</b>	<b>K2WTC-135B-67-N</b>	<b>K2WTC-150B-67-N</b>	<b>Not Permitted on Either Fuel</b>
Maximum Firing Rate, CH/DHW (RPM)	8600	8800	
Minimum Firing Rate (RPM)	1800	1900	
Default Light-off Rate (RPM)	4000	4000	
<b>Model</b>	<b>K2WTC-135B-67-P</b>	<b>K2WTC-150B-67-P</b>	
Maximum Firing Rate, CH/DHW (RPM)	7300	8800	
Minimum Firing Rate (RPM)	1800	1900	
Default Light-off Rate (RPM)	4500	4000	
<b>Altitude</b>	<b>7801-10100ft</b>		
<b>Model</b>	<b>K2WTC-135B-70-N</b>	<b>K2WTC-150B-70-N</b>	<b>Not Permitted on Either Fuel</b>
Maximum Firing Rate, CH/DHW (RPM)	8600	8850	
Minimum Firing Rate (RPM)	1800	1900	
Default Light-off Rate (RPM)	4500	4500	
<b>Model</b>	<b>LP Not Permitted</b>	<b>K2WTC-150B-70-P</b>	
Maximum Firing Rate, CH/DHW (RPM)		8200	
Minimum Firing Rate (RPM)		1900	
Default Light-off Rate (RPM)		4500	

### XIII. Operation F. Changing Adjustable Parameters (continued)

#### Sage Zone Panel Expected Heat Rate Adjustment Screens (HeatMatch Software)

The Control is shipped with defaults that will provide improved operation. Adjustment is only required to optimize setup.

The expected heat rate adjustment is used to better match boiler output to the home heating needs. After receiving a “call for heat” the Control first uses the expected heat rate value to set a maximum heat rate. The maximum heat rate is the highest heat rate that the boiler can fire to at that moment. The maximum heat rate is the summation of the expected heat rates for the active (turned on) zones. After establishing the maximum heat rate the Control then measures water temperature and fires the boiler only as hard as required for the heat demand.

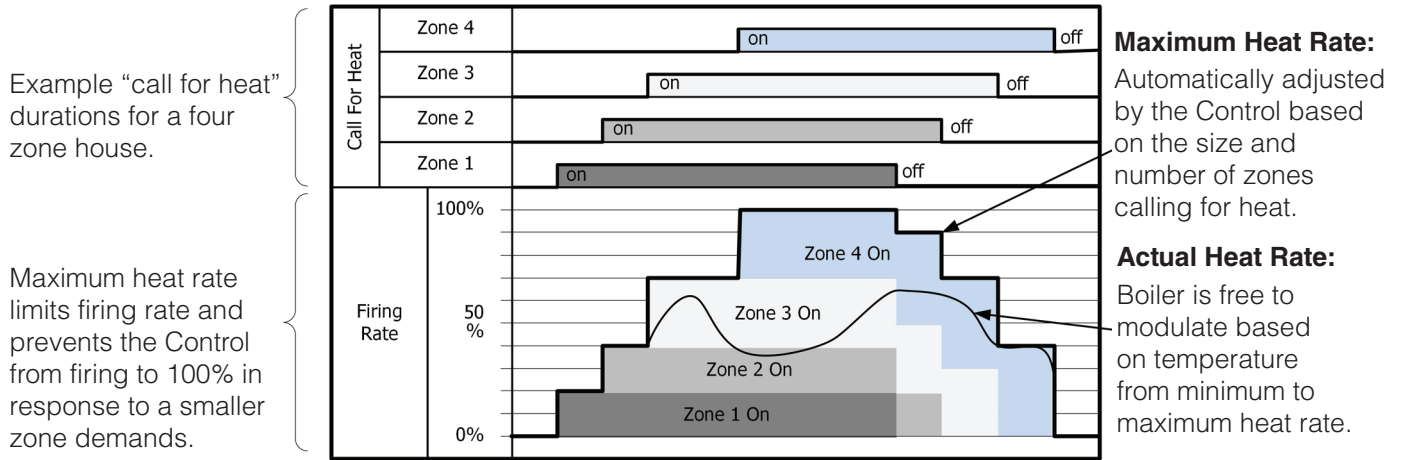


Figure 13.11: Four Zone House (with Sage Zone Control Connected)

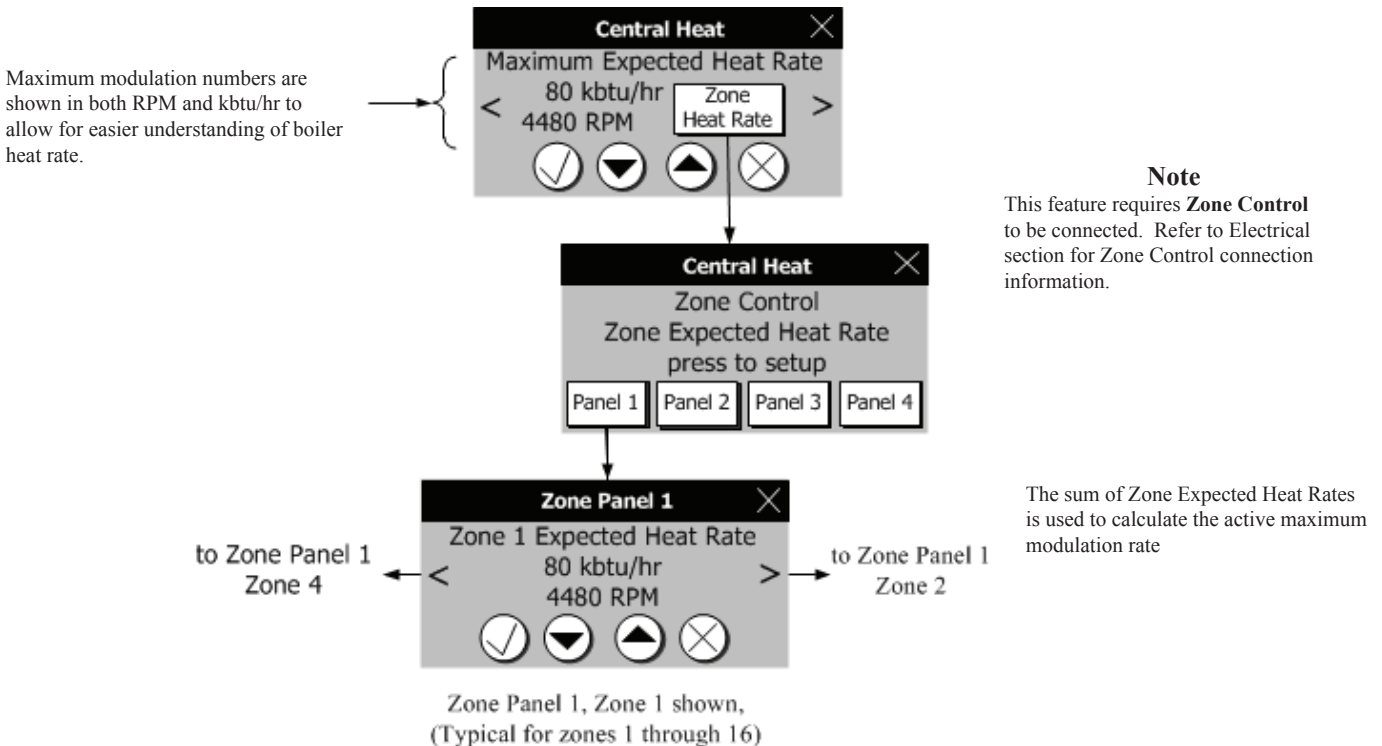
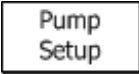


Figure 13.12: Expected Heat Rate Adjustment (with Sage Zone Control Connected)

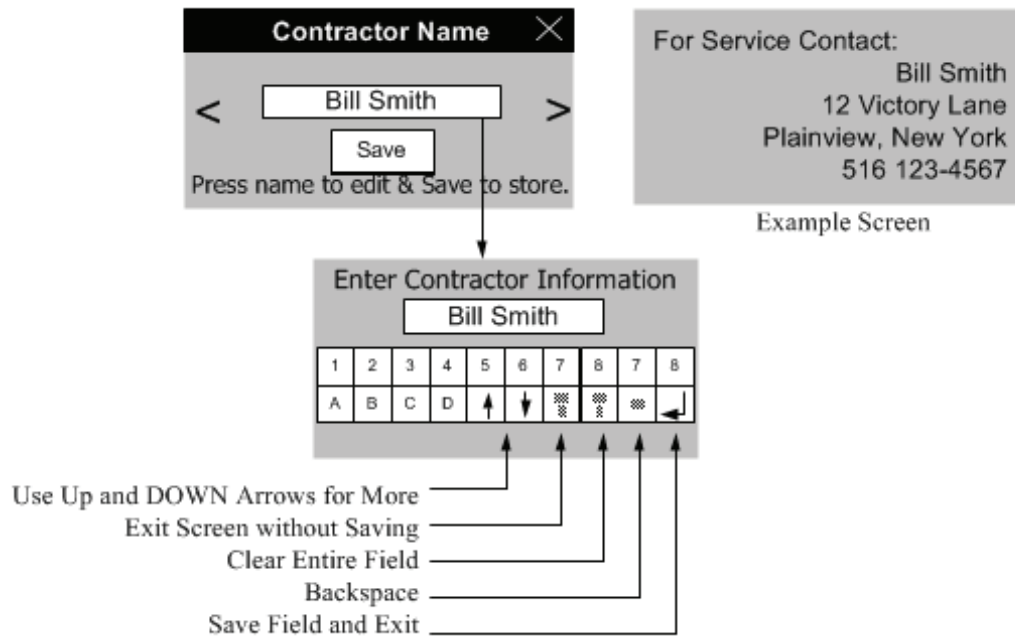
### XIII. Operation F. Changing Adjustable Parameters (continued)

“Press”  button to adjust the system pump operation:

Factory Setting	Range / Choices	Parameter and Description
Central Heat, No Priority	Central Heat, No Priority,  Central Heat, Optional Priority	<p><b>System Pump run pump for:</b> Activates the system pump output according to selected function.</p> <p>Central Heat, No Priority: Pump Runs during central heat, auxiliary heat and frost protection call for heat. Pump <u>does not start</u> for a DHW call for heat, but will run during Domestic Hot Water Priority if there is also a call for space heat.</p> <p>Central heat, Optional Priority: Pump Runs during central heat, auxiliary heat and frost protection call for heat. Pump <u>does not start</u> for a DHW call for heat and will be forced off if there is a DHW call for heat and Domestic Hot Water Priority is active.</p>

### XIII. Operation F. Changing Adjustable Parameters (continued)

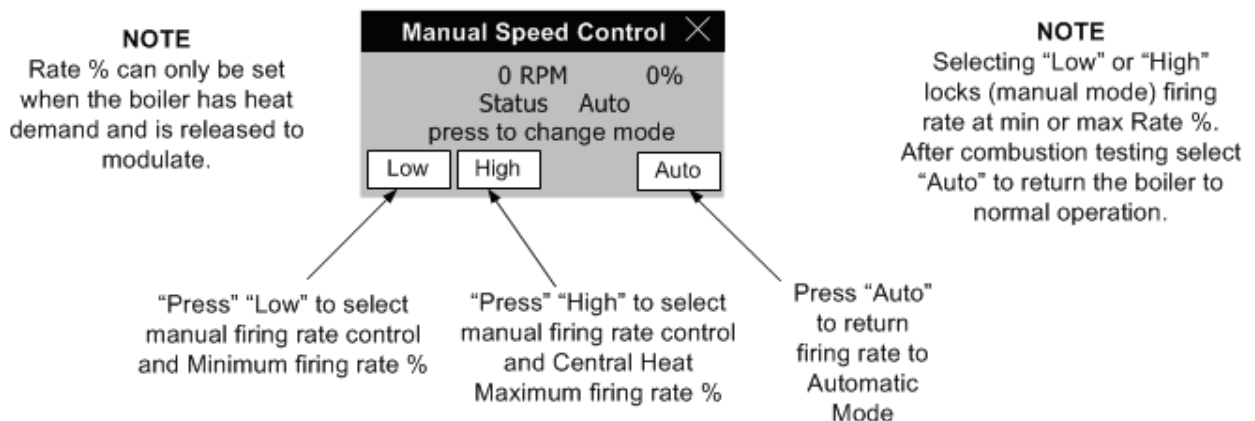
“Press” **Contractor Setup** button to access the following parameters:



Factory Setting	Range / Choices	Parameter and Description
Contractor Name	User defined	Contractor Name
Address Line 1	User defined	Contractor Address Line 1
Address Line 2	User defined	Contractor Address Line 2
Phone	User defined	Contractor Phone

“Press” **Manual Control** button to access the following screen:

The Manual Speed Control speed screen allows the technician to set firing rate at low or high speed for combustion testing.



### XIII. Operation F. Changing Adjustable Parameters (continued)

“Press” Central Heat button to access the following parameters:

Factory Setting	Range / Choices	Parameter and Description
180°F (82.2°C)	60°F to 190°F (16°C to 87.8°C)	<b>Central Heat Setpoint</b> Target temperature for the central heat priority. Value also used by the outdoor air reset function.
10°F (5.6°C)	2°F to 25°F (1.1°C to 14°C)	<b>Central Heat Diff Above</b> The boiler stops when the water temperature rises ‘Diff Above’ degrees above the setpoint. <b>NOTE</b> Never set the Diff Above such that the Setpoint plus the ‘Diff Above’ is greater than 200°F. the result may be nuisance manual reset hard lockouts. For example, if the setpoint is 180°F, the maximum ‘Diff Above’ is 20°F. Further, if the setpoint is 190°F, the maximum ‘Diff Above’ is 10°F.
5°F (2.8°C)	2°F to 25°F (1.1°C to 14°C)	<b>Central Heat Diff Below</b> The boiler starts when the water temperature drops ‘Diff Below’ degrees below the setpoint.
3	1 to 5	<b>Response Speed</b> This parameter adjusts the Central Heat temperature controller Proportion Integral Derivative (PID) values. Higher values cause a larger firing rate change for each degree of temperature change. If set too high firing rate “overshoots” required value, increases to high fire causing the temperature to exceed the “Diff Above” setpoint and cycle the boiler unnecessarily. Lower values cause a smaller firing rate change for each degree of temperature change. If set too low, the firing rate response will be sluggish and temperature will wander away from setpoint.
120 seconds	0 to 300 seconds	<b>Low Fire Hold Time</b> “Low Fire Hold Time” is the number of seconds the control will wait at low fire modulation rate before being released to modulate. After ignition and flame stabilization periods the firing rate is held at low fire for “Low Fire Hold Time”. This delay allows heat to travel out to the system and provide system feedback prior to the control modulating firing rate.
Supply Sensor	Supply Sensor, Header Sensor	<b>Modulation Sensor</b> Set to supply sensor only.

### XIII. Operation F. Changing Adjustable Parameters (continued)

“Press” Auxiliary Heat button to access the following parameters:

Factory Setting	Range / Choices	Parameter and Description
180°F (82.2°C)	60°F to 190°F (16°C to 87.8°C)	<b>Auxiliary Heat Setpoint</b> Target temperature for the Auxiliary Heat priority. Value also used by the outdoor air reset function.
10°F (5.6°C)	2°F to 25°F (1.1°C to 14°C)	<b>Auxiliary Heat Diff Above</b> The boiler stops when the water temperature rises ‘Diff Above’ degrees above the setpoint. <b>NOTE</b> Never set the Diff Above such that the Setpoint plus the ‘Diff Above’ is greater than 200°F. The result may be nuisance manual reset hard lockouts. For example, if the setpoint is 180°F, the maximum ‘Diff Above’ is 20°F. Further, if the setpoint is 190°F, the maximum ‘Diff Above’ is 10°F.
5°F (2.8°C)	2°F to 25°F (1.1°C to 14°C)	<b>Auxiliary Heat Diff Below</b> The boiler starts when the water temperature drops ‘Diff Below’ degrees below the setpoint.
3	1 to 5	<b>Response Speed</b> This parameter adjusts the Auxiliary Heat temperature controller Proportion Integral Derivative (PID) values. Higher values cause a larger firing rate change for each degree of temperature change. If set too high firing rate “overshoots” required value, increases to high fire causing the temperature to exceed the “Diff Above” setpoint and cycle the boiler unnecessarily. Lower values cause a smaller firing rate change for each degree of temperature change. If set too low, the firing rate response will be sluggish and temperature will wander away from setpoint.
Disable	Disable, Enable	<b>Auxiliary Priority Over Central Heat</b> This parameter allows the Auxiliary Heat demand to be higher or lower priority than Central Heat demand. When both demands are active at the same time the Control uses the Setpoint, Diff Above and Diff Below for the demand that has priority. Disabled                      Auxiliary Heat is lower priority than Central Heat demand. Enable                         Auxiliary Heat is higher priority than Central Heat demand.
Supply Sensor	Supply Sensor, Header Sensor	<b>Modulation Sensor</b> Set to supply sensor only.

### XIII. Operation F. Changing Adjustable Parameters (continued)

“Press” Domestic Hot Water button to access the following parameters:

Factory Setting	Range / Choices	Parameter and Description
120F (49C)	105F - 140F (41C - 60C)	<p><b>Domestic Hot Water Setpoint</b></p> <p>During a DHW demand, the boiler will attempt to maintain this temperature at the DHW sensor located just upstream of the hot water outlet connection. Under certain conditions, such as very low flow rates and transitions from a space heating space heating demand, the DHW temperature may significantly exceed this set-point. For this reason, <b>an installer supplied tempering valve is required for all installations</b> (see Warnings on Page 80 and below). This tempering valve should be set to the value desired at fixtures. In general, the DHW set point should be set just far enough above the tempering valve set-point for the tempering valve to regulate temperature properly (see tempering valve instructions).</p>
60	30 to 120 Minutes	<p><b>Priority Time</b></p> <p>This boiler can only respond to one demand (either space heat or domestic hot water) at a time. When there are simultaneous calls for space heat and domestic hot water, the domestic hot water demand will have priority for the duration of this “Priority time”. At the end of that time, the boiler will respond to the call for space heat and no domestic hot water will be available until there is an interruption in one of the two demands. During the priority time itself any interruption in the DHW or space heat demand will also “reset the clock”; both demands need to be present on a continuous basis for the priority time to expire.</p>

**⚠ DANGER! Water temperature over 125°F (52°C) can cause severe burns instantly or death from scalds.**

- Installation of an ASSE 1017 or ASSE 1070 certified tempering valve is **REQUIRED** as part of the installation of this boiler (see Section X). This valve serves as the primary means of regulating water temperature supplied to fixtures.
- When making adjustments to the tempering valve and/or the domestic water set point, observe the relationship between domestic water temperature and time required for scalding to occur shown in Table 13.3. Also keep in mind that children, disabled and the elderly are at highest risk of being scalded.

**Table 13.3: Approximate Time/Temperature Relationships For Scalding**

120°F	More than 5 minutes
125°F	1-1/2 to 2 minutes
130°F	About 30 seconds
135°F	About 10 seconds
140°F	Less than 5 seconds
145°F	Less than 3 seconds
150°F	About 1-1/2 seconds
155°F	About 1 second



### XIII. Operation F. Changing Adjustable Parameters (continued)

“Press” Outdoor Reset  
Central Heat button to access the following parameters:

Factory Setting	Range / Choices	Parameter and Description
Enabled	Enable Disable	<p><b>Central Heat Outdoor Reset Enable</b> If an outdoor sensor is installed and Outdoor Reset is Enabled, the boiler will automatically adjust the heating zone set point temperature based on the outdoor reset curve in Figure 8. The maximum set point is defined by the Central Heat Setpoint [factory set to 180°F (82.2°C)] when the outdoor temperature is 0°F (-18°C) or below. The minimum set point temperature shown is 130°F (54.4°C) [adjustable as low as 80°F (26.7°C)] when the outdoor temperature is 50°F (10°C) or above. As the outdoor temperature falls the supply water target temperature increases. For example, if the outdoor air temperature is 30°F, (-1.1°C) the set point temperature for the supply water is 150°F (65.6°C).</p> <p>Disable    <u>Do Not</u> Calculate setpoint based on outdoor temperature Enable     Calculate the temperature setpoint based on outdoor temperature using a reset curve defined by Low Outdoor Temp, High Outdoor Temp, Low Boiler Water Temp, Min Boiler Temp and Central Heat Setpoint and Boost Time parameters.</p>
0°F (-18°C)	-40°F to 100°F (-40°C to 37.8°C)	<p><b>Central Heat Low Outdoor Temperature</b> The Low Outdoor Temperature parameter is also called “Outdoor Design Temperature”. This parameter is the outdoor temperature used in the heat loss calculation. It is typically set to the coldest outdoor temperature.</p>
70°F (21.1°C)	32°F to 100°F (0°C to 37.8°C)	<p><b>Central Heat High Outdoor Temperature</b> The High Outdoor Temperature parameter is the outdoor temperature at which the Low Boiler Water Temperature is supplied. This parameter is typically set to the desired building temperature.</p>
110°F (43.3°C)	70°F to 190°F (21.1°C to 87.8°C)	<p><b>Central Heat Low Boiler Water Temperature</b> The Low Boiler Water Temperature parameter is the operating setpoint when the High Outdoor Temperature is measured. If the home feels cool during warm outdoor conditions, the Low Boiler Water Temperature parameter should be increased.</p>
130°F (54.4°C)	80°F to 190°F (26.7°C to 87.8°C)	<p><b>Minimum Boiler Temperature (Central Heat and Auxiliary Heat)</b> The Minimum Boiler Temperature parameter sets a low limit for the Reset setpoint. Set this parameter to the lowest supply water temperature that will provide enough heat for the type radiation used to function properly. Always consider the type of radiation when adjusting this parameter.</p>
20 Minutes	0-1800 Seconds (0-30 Minutes)	<p><b>Central Heat Boost Time</b> When the Central Heat Setpoint is decreased by Outdoor Reset settings, the Boost Time parameter is used to increase the operating setpoint when the home heat demand is not satisfied after the Boost Time setting is exceeded. When heat demand has been “on” continuously for longer than the Boost Time parameter the operating setpoint is increased by 10°F (5.6°C). The highest operating setpoint from Boost Time is current Central Heat Setpoint. A setting of 0 seconds disables this feature. Boost is not used when Sequence Master is enabled.</p>

### XIII. Operation F. Changing Adjustable Parameters (continued)

“Press” Outdoor  
Reset Aux button to access the following parameters:

Factory Setting	Range / Choices	Parameter and Description
Enabled	Enable Disable	<p><b>Auxiliary Heat Outdoor Reset Enable</b></p> <p>If an outdoor sensor is installed and Outdoor Reset is Enabled, the boiler will automatically adjust the heating zone set point temperature based on the outdoor reset curve in Figure 8. The maximum set point is defined by the Central Heat Setpoint [factory set to 180°F (82.2°C)] when the outdoor temperature is 0°F (-18°C) or below. The minimum set point temperature shown is 130°F (54.4°C) [adjustable as low as 80°F (26.7°C)] when the outdoor temperature is 50°F (10°C) or above. As the outdoor temperature falls the supply water target temperature increases. For example, if the outdoor air temperature is 30°F, (-1.1°C) the set point temperature for the supply water is 150°F (65.6°C).</p> <p>Disable    <u>Do Not</u> Calculate setpoint based on outdoor temperature            Enable    Calculate the temperature setpoint based on outdoor temperature using a reset curve defined by Low Outdoor Temp, High Outdoor Temp, Low Boiler Water Temp, Min Boiler Temp and Central Heat Setpoint and Boost Time parameters.</p>
0°F (-18°C)	-40°F to 100°F (-40°C to 37.8°C)	<p><b>Auxiliary Heat Low Outdoor Temperature</b></p> <p>The Low Outdoor Temperature parameter is also called “Outdoor Design Temperature”. This parameter is the outdoor temperature used in the heat loss calculation. It is typically set to the coldest outdoor temperature.</p>
70°F (21.1°C)	32°F to 100°F (0°C to 37.8°C)	<p><b>Auxiliary Heat High Outdoor Temperature</b></p> <p>The High Outdoor Temperature parameter is the outdoor temperature at which the Low Boiler Water Temperature is supplied. This parameter is typically set to the desired building temperature.</p>
110°F (43.3°C)	70°F to 190°F (21.1°C to 87.8°C)	<p><b>Auxiliary Heat Low Boiler Water Temperature</b></p> <p>The Low Boiler Water Temperature parameter is the operating setpoint when the High Outdoor Temperature is measured. If the home feels cool during warm outdoor conditions, the Low Boiler Water Temperature parameter should be increased.</p>
20 Minutes	0-1800 Seconds (0-30 Minutes)	<p><b>Auxiliary Heat Boost Time</b></p> <p>When the Auxiliary Heat Setpoint is decreased by Outdoor Reset settings, the Boost Time parameter is used to increase the operating setpoint when the home heat demand is not satisfied after the Boost Time setting is exceeded. When heat demand has been “on” continuously for longer than the Boost Time parameter the operating setpoint is increased by 10°F (5.6°C). The highest operating setpoint from Boost Time is current Auxiliary Heat Setpoint. A setting of 0 seconds disables this feature.</p>

### XIII. Operation F. Changing Adjustable Parameters (continued)

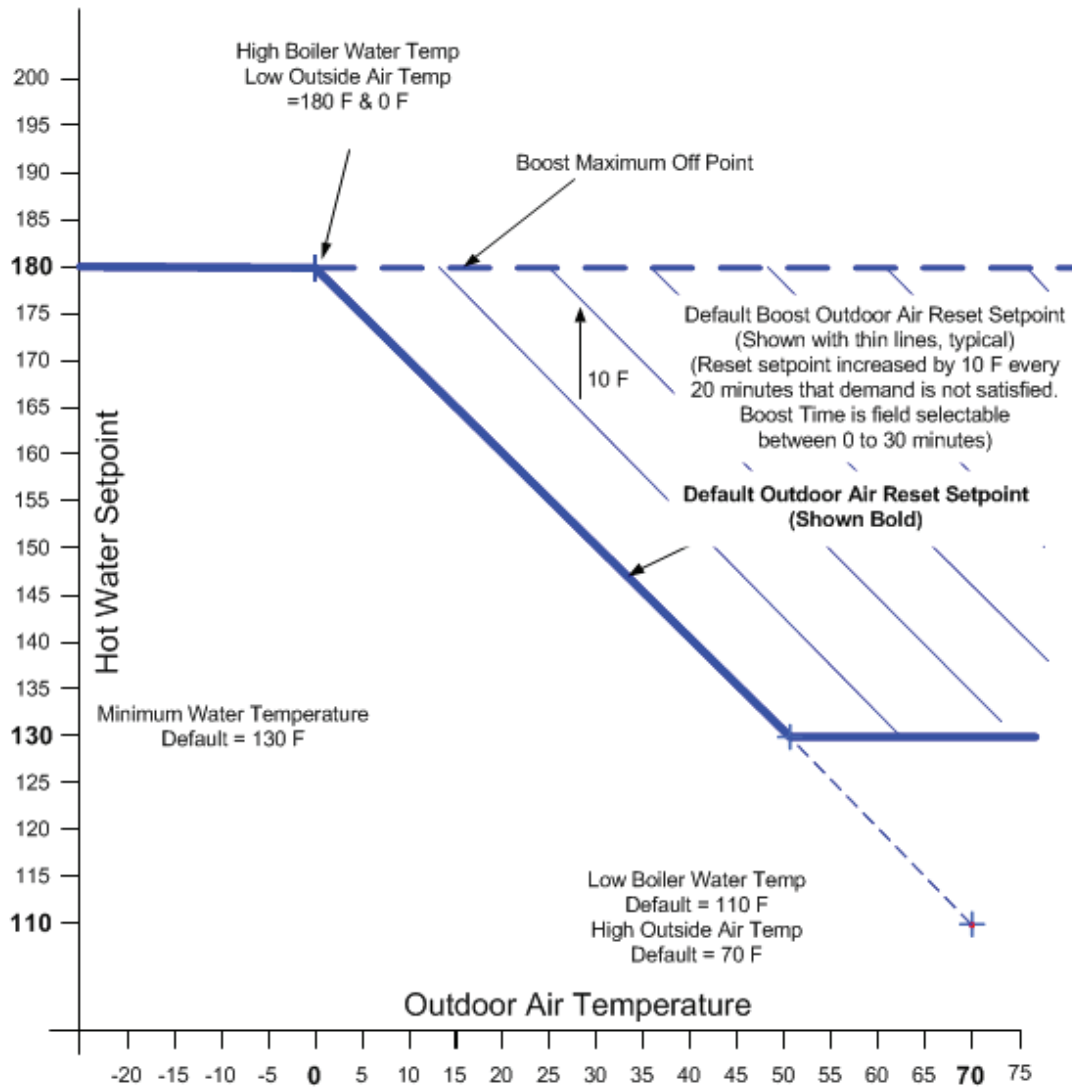
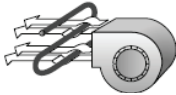
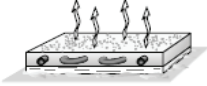
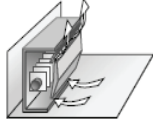
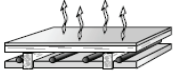




Figure 13.13: Outdoor Reset Curve

Central Heat Setpoint	Heating Element Type		Central Heat Setpoint	Heating Element Type	
180°F to 190°F (82.2°C to 87.8°C)	Fan Coil		100°F to 140°F (37.8°C to 60°C)	In Slab Radiant High Mass Radiant	
160°F to 190°F (71.1°C to 87.8°C)	Convection Baseboard Fin Tube Convective		130°F to 160°F (54.4°C to 71.1°C)	Staple-up Radiant Low Mass Radiant	
130°F to 160°F (54.4°C to 71.1°C)	Radiant Baseboard		140°F to 160°F (60°C to 71.1°C)	Radiators	

### XIII. Operation F. Changing Adjustable Parameters (continued)

“Press” Sequencer Master button to access the following parameters:

Factory Setting	Range / Choices	Parameter and Description
Disable	Enable, Disable	<b>Master Enable/Disable</b> Master should always be Disabled.

“Press” Sequence Slave button to access the following parameters if this boiler is to be used as a slave in a multiple boiler system:

Factory Setting	Range / Choices	Parameter and Description
None	1-8	<b>Boiler Address</b> Each boiler must be given a unique address. When “Normal” slave selection order is used, the boiler address is used by the Master Sequencer as the boiler start order. The boiler address is also the Modbus Address when a Energy Management System is connected.
Normal	Use Boiler First, Normal, Use Boiler Last	<b>Slave Selection Order</b> “Use Boiler First”; places the Slave in the lead permanently. “Normal”; firing order follows boiler number (1,2,3,..) order. “Use Boiler Last”; places the slave last in the firing order.

“Press” EMS button to access the following parameters:

Factory Setting	Range / Choices	Parameter and Description
Local	Local, 4-20mA	<b>Central Heat Modulation Source</b> This parameter should always be set to “Local”.
Local	Local, 4-20mA	<b>Central Heat Setpoint Source</b> This parameter should always be set to “Local”.
Local	Local, Modbus	<b>Central Heat Demand Source</b> This parameter enables a Modbus input to be take the place of the Heating Thermostat Input: Local      Local Heating Thermostat input is used for Central Heat demand. Modbus    Modbus input is used for Central Heat demand.

### **Important Product Safety Information** **Refractory Ceramic Fiber Product**



The Service Parts list designates parts that contain refractory ceramic fibers (RCF). RCF has been classified as a possible human carcinogen. When exposed to temperatures above 1805°F, such as during direct flame contact, RCF changes into crystalline silica, a known carcinogen. When disturbed as a result of servicing, these substances become airborne and, if inhaled, may be hazardous to your health.

#### AVOID Breathing Fiber Particulates and Dust

#### **Precautionary Measures:**

Do not remove or replace RCF parts or attempt any service work involving RCF without wearing the following protective gear:

1. A National Institute for Occupational Safety and Health (NIOSH) approved respirator
  2. Long sleeved, loose fitting clothing
  3. Gloves
  4. Eye Protection
- Take steps to assure adequate ventilation.
  - Wash all exposed body areas gently with soap and water after contact.
  - Wash work clothes separately from other laundry and rinse washing machine after use to avoid contaminating other clothes.
  - Discard used RCF components by sealing in an airtight plastic bag. RCF and crystalline silica are not classified as hazardous wastes in the United States and Canada.

#### **First Aid Procedures:**

- If contact with eyes: Flush with water for at least 15 minutes. Seek immediate medical attention if irritation persists.
- If contact with skin: Wash affected area gently with soap and water. Seek immediate medical attention if irritation persists.
- If breathing difficulty develops: Leave the area and move to a location with clean fresh air. Seek immediate medical attention if breathing difficulties persist.
- Ingestion: Do not induce vomiting. Drink plenty of water. Seek immediate medical attention.

## XIV. Service and Maintenance (continued)



**Asphyxiation Hazard. Fire Hazard. Explosion Hazard.** This boiler requires regular maintenance and service to operate safely. Follow the instructions contained in this manual.

Improper installation, adjustment, alteration, service or maintenance can cause property damage, personal injury or loss of life. Read and understand the entire manual before attempting installation, start-up operation, or service. Installation and service must be performed only by an experienced, skilled, and knowledgeable installer or service agency.



**Explosion Hazard. Electrical Shock Hazard. Burn Hazard.** This boiler uses flammable gas, high voltage electricity, moving parts, and very hot water under high pressure. Assure that all gas and electric power supplies are off and that the water temperature is cool before attempting any disassembly or service.

Do not attempt any service work if gas is present in the air in the vicinity of the boiler. Never modify, remove or tamper with any control device.



This boiler must only be serviced and repaired by skilled and experienced service technicians.

- If any controls are replaced, they must be replaced with identical models.
- Read, understand and follow all the instructions and warnings contained in all the sections of this manual.
- If any electrical wires are disconnected during service, clearly label the wires and assure that the wires are reconnected properly.
- Never jump out or bypass any safety or operating control or component of this boiler.
- Assure that all safety and operating controls and components are operating properly before placing the boiler back in service.
- Annually inspect all vent gaskets and replace any exhibiting damage or deterioration.
- **Burn Hazard.** This boiler contains very hot water under pressure. Do not unscrew any pipe fittings nor attempt to disconnect any components of this boiler without positively assuring the water is cool and has no pressure. Always wear protective clothing and equipment when installing, starting up or servicing this boiler to prevent scald injuries. Do not rely on the pressure and temperature gauges to determine the temperature and pressure of the boiler. This boiler contains components which become very hot when the boiler is operating. Do not touch any components unless they are cool.
- **Respiratory Hazard.** Boiler materials of construction, products of combustion and the fuel contain alumina, silica, heavy metals, carbon monoxide, nitrogen oxides, aldehydes and/or other toxic or harmful substances which can cause death or serious injury and which are known to the state of California to cause cancer, birth defects and other reproductive harm. Always use proper safety clothing, respirators and equipment when servicing or working nearby the appliance.
- Failure to follow all instructions in the proper order can cause personal injury or death. Read all instructions, including all those contained in component manufacturers manuals which are provided with the boiler before installing, starting up, operating, maintaining or servicing.

All cover plates, enclosures and guards must be in place at all times.

## XIV. Service and Maintenance (continued)

**NOTICE** Warranty does not cover boiler damage or malfunction if the following steps are not performed at the intervals specified.

1. **Continuously:**
  - a. **Keep the area around the boiler** free from combustible materials, gasoline and other flammable vapors and liquids.
  - b. **Keep the area around the combustion air inlet terminal** free from contaminants.
  - c. **Keep the boiler room ventilation openings** open and unobstructed.
2. **Monthly Inspections:**
  - a. **Inspect the vent piping and outside air intake piping** to verify they are open, unobstructed and free from leakage or deterioration. Call the service technician to make repairs if needed.
  - b. **Inspect the condensate drain system** to verify it is leak tight, open and unobstructed. Call the service technician if the condensate drain system requires maintenance.
  - c. **Inspect the water and gas lines** to verify they are free from leaks. Call the service technician to make repairs if required.

**NOTICE** Water leaks can cause severe corrosion damage to the boiler or other system components. Immediately repair any leaks found.

4. **Annual Inspections and Service:** In addition to the inspections listed above, the following should be performed by a service technician once every year.
  - a. **Follow the procedure** for turning the boiler off found in the Lighting and Operating Instructions (Section XII "Start-up and Checkout").
  - b. **Turn off all power** to the boiler.
  - c. **Inspect the wiring** to verify the conductors are in good condition and attached securely.



**CAUTION** ATTENTION! Electrical Shock Hazard. Label all wires prior to disconnection when servicing controls. Wiring errors can cause improper and dangerous operation. Verify proper operation after servicing.

Au moment de l'entretien des commandes, étiquetez tous les fils avant de les débrancher. Les erreurs de câblage peuvent nuire au bon fonctionnement et être dangereuses. S'assurer que l'appareil fonctionne adéquatement une fois k'entretien terminé.

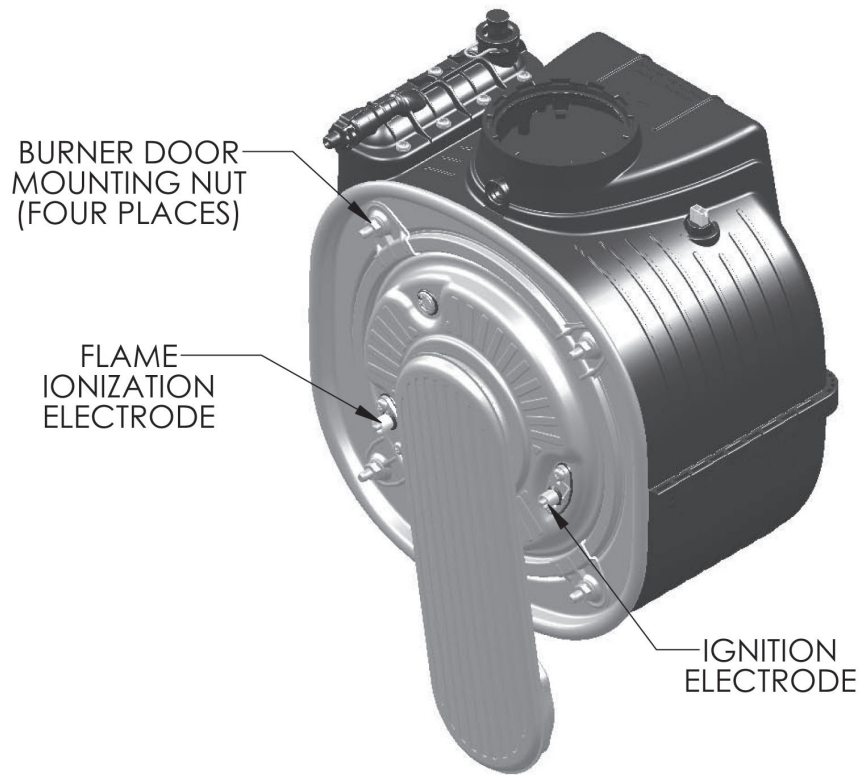
- d. **Verify that the gas shutoff** shown in Figure 8.1 is closed.
- e. **Disconnect the union** under the boiler (Figure 8.1).



**WARNING** Fire Hazard. Explosion Hazard. Always use a back-up wrench on the gas union when making or breaking this connection. Failure to do so can cause adjacent threaded connections to loosen or damage to the gas valve. Check all internal gas piping for leaks any time it is disconnected or disturbed during servicing. Fire Hazard. Explosion Hazard.

- f. **Unplug the electrical connection** to the gas valve.
- g. **Disconnect the air proving switch tube** from the gas valve outlet tap.
- h. **Unplug the power and speed control cables** from the blower.

**XIV. Service and Maintenance (continued)**



**Figure 14.1: Flame Ionization Electrode and Ignition Electrode Location**



## XIV. Service and Maintenance (continued)

- i. **Unplug the ignition, ground, and flame rod wires** from the ignition electrode and the flame rod (Figure 14.1).
- j. **Use a 10 mm wrench to remove the four nuts** securing the fire door to the heat exchanger (Figure 14.1). Carefully remove the door/blower/gas valve assembly from the heat exchanger, being careful not to damage the refractory insulation on the inside of the door (see Refractory Warning on next page) or the electrodes.
- k. **Inspect the heat exchanger combustion chamber and vacuum** any debris found on the coil surfaces. If necessary, the coils may be brushed with a nonabrasive, nonmetallic brush. Do not use cleaning agents, solvents, acid or alkali products of any type to clean the heat exchanger .
- l. **Inspect the target wall and fire door insulation.** If either shows signs of damage, it must be replaced.
- m. **Inspect the burner for heat damage** or other deterioration. Use a non-metallic brush or source of compressed air to clean off dust or debris from ports.
- n. **Inspect the ignition electrode and flame rod** for deposits. Clean any found with steel wool. Do not use sand paper or Emory cloth for this cleaning. Inspect the ceramic portion of both of these parts for cracks and replace if any are found. Verify that the ignition electrode gap is within the range shown in Figure 14.2.
- o. **Inspect the blower gas valve assembly**, looking for dust, lint, or other debris that may have been drawn into this assembly. Excessive deposits may be vacuumed out. Verify that “flappers” in venturi move freely. Inspect all rubber and plastic components on the blower/gas valve assembly, looking for deterioration. Replace blower and/or gas valve if deterioration is found.
- p. **Inspect and clean the condensate trap.** Place a bucket under the condensate cleanout cap on the bottom of the boiler (see Figure 2.1) to catch water in the trap as well as the ball and ball support. Unscrew the cap, being careful not to lose the ball or ball support. Flush any debris found in the trap with water – do not use other cleaning agents. Reassemble the trap as shown in Figure 14.3.



**Asphyxiation Hazard. Do not operate the boiler without the ball and ball support in place. Doing so could result in flue gas leakage into the indoors resulting in personal injury or death from Carbon Monoxide (CO) poisoning.**

**NOTICE** Attempting to clean the heat exchanger or trap with anything other than water could result in condensate backup, causing the boiler to shut-down.

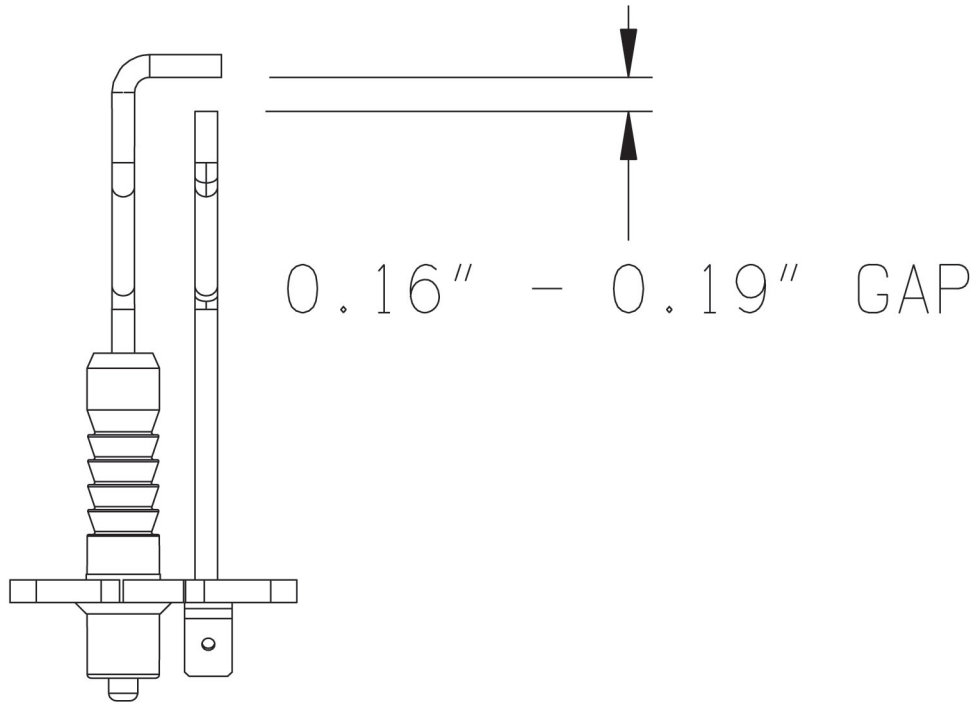
- q. **Reinstall the fire door/blower/gas valve assembly**, following the above steps in reverse order.



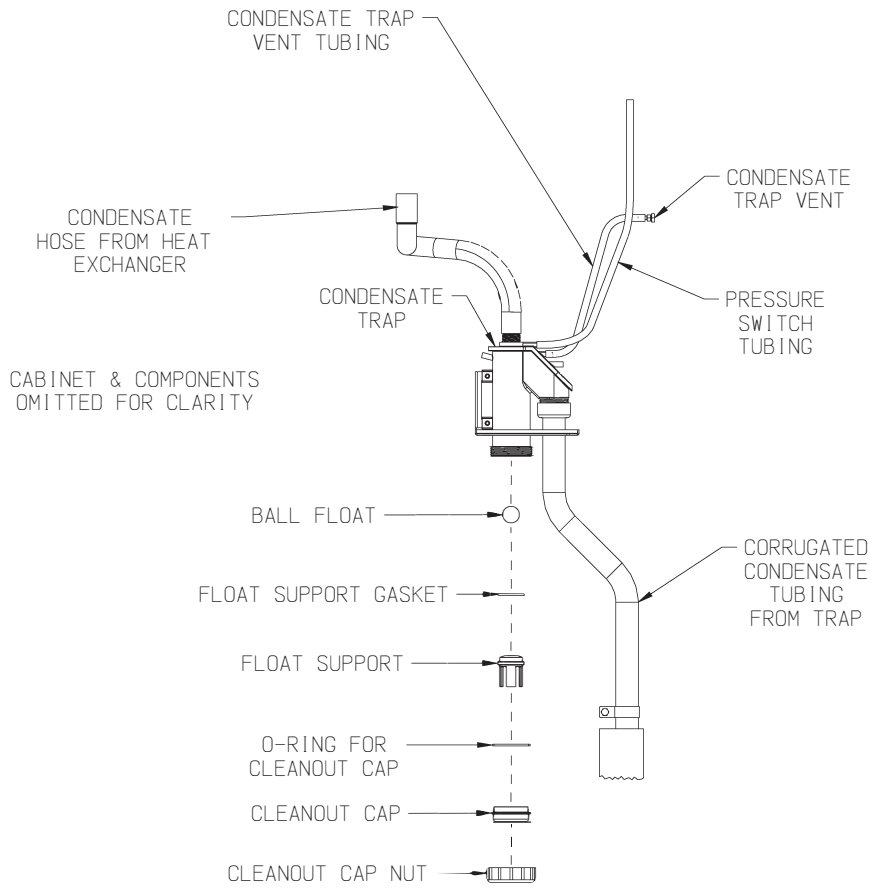
**Do not over tighten fire door mounting nuts. Doing so could break the fire door mounting studs. If any of these studs are damaged, the heat exchanger must be replaced. Use of a short 10 mm box wrench will reduce the risk of damaging these studs.**

- r. **Inspect the vent system to verify that:**
  - All gaskets and joints between the boiler heat exchanger and terminal are leak tight.
  - All supports are intact and vent system is properly pitched
  - All pipe is in good condition. Look for damage such as cracks, heat distortion, discoloration, and embrittlement. If any such damage is found, the pipe must be replaced and the cause of the damage identified.
  - Vent/Intake terminals are in good condition, free from blockages, and still correctly located relative to doors, windows, decks, etc.
  - There is no gasoline, flammable liquids/vapors, or halogen based products stored in the vicinity of the vent or inlet terminals. Also verify that there are no chemical products containing chlorine, chloride based salts, chlorofluorocarbons, paint removers, cleaning solvents, or detergents stored near the air intake terminal.

**XIV. Service and Maintenance (continued)**



**Figure 14.2: Ignition Electrode Gap**



**Figure 14.3: Condensate Trap Exploded Parts View**

## XIV. Service and Maintenance (continued)

Refer to Section VII “Venting” to re-assemble any vent system components that are disassembled during this inspection and for details on supporting, pitching, and terminating the vent system.

- s. **Replace any wiring** which has been disconnected.
- t. **Inspect the hydronic system and domestic water piping.** Look for leaks and repair any found. If system contains antifreeze, or other additives, test and/or maintain them as directed by the additive manufacturer. Refer to Section XII “Start-up and Checkout” for important information on boiler water and the use of boiler water additives.

**NOTICE** Do not remove return pipe connection from heat exchanger to service the circulator.

- u. **Test the boiler flow switch.** To do this:
  - Start with the boiler in standby.
  - Either close a shut-off in the boiler loop or unplug the boiler pump at connector BP1. (see Figure 11.7)
  - Initiate a call for heat and confirm that the boiler shows an Active Fault indicating that the flow switch is open.



**WARNING** If burner comes on with no flow through the boiler, there is a problem with the flow switch. Turn the boiler off immediately. Failure to do so could cause severe heat exchanger damage.

- v. **Follow ALL instructions in** Section XII “Start-up and Checkout” to place the boiler back in service, including the performance of a combustion test.

## XV. Troubleshooting



### WARNING

Electrical Shock Hazard. Turn off power to boiler before working on wiring.

### A. Troubleshooting problems where no error code is displayed.

Problem	Condition	Possible Causes
Inadequate Space Heat	Boiler not responding to call for heat, "Status" and "Priority" show "Standby".	Boiler is not seeing call for heat. Check thermostat or zone wiring for loose connection, mis-wiring, or defective thermostat/zone control.
	Boiler not responding to a call for heat, "Status" shows "Standby" and "Priority" shows "Central Heat".	Supply temperature is greater than set point: <ul style="list-style-type: none"> <li>Water flow through system loop non-existent or too low, due to inoperable system circulator, air, or failure of zone valve(s) to open.</li> <li>May be normal if heating load is below the boiler's minimum firing rate (e.g. if one "microzone" is calling for heat).</li> <li>Defective diverting valve or loose electrical connection to valve.</li> </ul>
	Home is cold during mild weather days	Increase Low Boiler Water Temperature parameter 5°F (2.8°C) per day.
	Home is cold during cold weather days	Increase High Boiler Water Temperature parameter 5°F (2.8°C) per day
	Priority shows Domestic Hot Water	Normal operation: Boiler does not provide space heat when it is responding to a DHW demand. Priority time can be shortened, but this may cause a lack of hot water at fixtures during long DHW draws.
No hot water at fixtures	Boiler not responding to call for DHW, "Status" and "Priority" show "Standby".	Boiler is not seeing DHW demand: <ul style="list-style-type: none"> <li>Verify that draw rate through boiler itself is at least 0.5GPM (a higher draw may be needed at the fixture due to mixing at the fixture and/or the tempering valve).</li> <li>Defective DHW flow switch or loose connection at switch</li> </ul>
	Boiler was responding to call for DHW, but priority is now shown as Central Heat	Simultaneous calls for DHW and space heat were present for the priority time (default is one hour). Increase priority time.
Inadequate hot water at fixtures	Boiler not firing during a call a call for DHW, "Status" shows "Standby" and "Priority" shows "Domestic Hot Water".	DHW temperature is greater than set point. <ul style="list-style-type: none"> <li>Normal at very low draw rates (boiler will cycle on and off).</li> <li>Misadjusted or defective tempering valve</li> </ul>
	Boiler firing continuously at 100%	DHW draw and/or temperature rise is in excess of capacity shown in Table 2.2.
	Boiler not firing continuously at 100%, but temperature is too low.	<ul style="list-style-type: none"> <li>Mixing valve set too low.</li> <li>DHW setting on boiler lower than, or too close to, tempering valve setting.</li> <li>Fouled plate heat exchanger</li> </ul> SEE WARNINGS ON PAGE 119 BEFORE MAKING ADJUSTMENTS TO BOILER OR VALVE

## XV. Troubleshooting (continued)

### B. Display Faults:

Faults are investigated by selecting the “Help” button from the “Home” screen. When a fault is active the “Help” button flashes and the home screen turns a red color. Continue to select flashing buttons to be directed to the Fault cause.

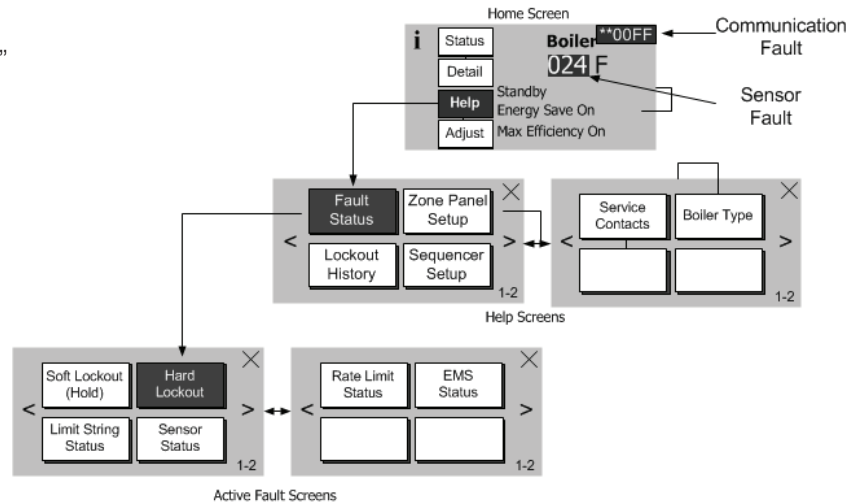


Figure 15.1: Help Menu

Indication	Condition	Possible Cause
Display Completely Dark Fan off, LWCO lights off, no green power light on Control	No 120Vac Power at Boiler	Check breaker and wiring between breaker panel and boiler. - Blown high voltage fuse, Replacement Fuse Kit, part number 105349-01.
Display Completely Dark, Fan running	No 24Vac Power to Control	- Loose 120Vac connection wiring between boiler J-Box and transformer - Loose 24 Vac connection wiring between transformer and Control.
Blinking Green power light on Control	Control Fault	- The green light is connected to internal power supply. The power supply is repeatedly starting and stopping (not normal) making the light flash. The microprocessors are not running. - Try disconnecting all terminals except 24VAC to power the Control. The green light should be steady. If it is not, then the control is defective. If steady, start plugging in all the connectors while watching the green light. When faulty wiring reconnected, green light will begin to flash.
Display Completely Dark but Boiler fires	No 5 Vdc Power to Display	- Loose 5 Vdc connection wiring between display and Control - Defective Display or Control.
<b>**00FF</b> or <b>**ERFF</b>	Display lost Communication with Control	- Loose or defective display harness - Defective Display - Defective Control
<b>ER0011</b>	Adjustment Mode Password Timeout	- The Control and Display are <b>NOT</b> defective. The password has timed out. Simply cycle power to the Display to restore operation.
<b>ER0012</b>	Control Failed	- Defective Control.

## XV. Troubleshooting (continued)

### C. Help Screen Faults

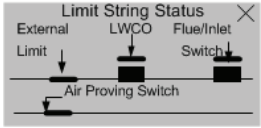
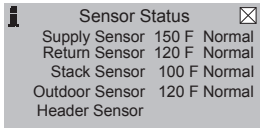

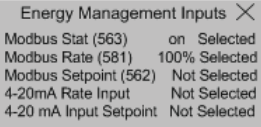
Indication	Condition	Possible Cause
<div style="background-color: black; color: white; padding: 5px; text-align: center;">Zone Panel Setup</div> Flashing	<div style="background-color: black; color: white; padding: 5px; text-align: center;">Zone Panel 1 Setup</div> Flashing	Zone Panel 1 communication lost, typical for Panel 1 through 4: The zone panel's communication was established and then lost. Check the following to correct the issue: <ul style="list-style-type: none"> <li>• Wiring between panel and boiler.</li> <li>• Zone panel DIP switch settings have changed:                             <ul style="list-style-type: none"> <li>- Set Master/Slave switch to "Master"</li> <li>- Set Zone Control switch ZC1 to "ON"</li> <li>- Cycle power</li> </ul> </li> </ul>
	<div style="background-color: black; color: white; padding: 5px; text-align: center;">Zone Panel Failure</div> Flashing	Zone Panel Electronics Failure: A Zone Panel
	<div style="background-color: black; color: white; padding: 5px; text-align: center;">Duplicate Zone</div> Flashing	Duplicate Zone: The Control has detected duplicate zone panel numbers. Check the following to correct: <ul style="list-style-type: none"> <li>• Each Zone Control DIP Switch must be set to a Unique setting:</li> </ul> <div style="text-align: center;"> <p>The diagram illustrates four zone panels, each with a BT/LT switch and four Zone Control (ZC) switches (ZC1-ZC4). Panel 1 has ZC1 set to ON and all other switches (BT/LT, ZC2, ZC3, ZC4) set to OFF. Panel 2 has ZC2 set to ON and all other switches set to OFF. Panel 3 has ZC3 set to ON and all other switches set to OFF. Panel 4 has ZC4 set to ON and all other switches set to OFF.</p> </div> <p>Note that when multiple ZC switches are set on ON the Zone Panel is reported as Zone Panel 1.</p>
<div style="background-color: black; color: white; padding: 5px; text-align: center;">Sequencer Setup</div>	Sequencer Setup Fault	This alarm is active if the slave boiler has lost communication with the Sequence Master. Check the following: <ul style="list-style-type: none"> <li>- RJ 45 peer-to-peer network disconnected</li> <li>- Sequencer Master was Enabled and then Disabled</li> <li>- Master's Boiler has been powered down.</li> <li>- To clear fault restore communication or cycle power</li> </ul>
<div style="background-color: black; color: white; padding: 5px; text-align: center;">Boiler Size Setup</div>	Boiler Size Fault	<p style="text-align: center;"><b>WARNING!</b></p> Boiler size setting may not match actual boiler size. The Boiler size setting determines min, max and light-off blower speeds. Incorrect boiler size can cause hazardous burner conditions and improper operation that may result in PROPERTY LOSS, PHYSICAL INJURY, OR DEATH. Refer to page 113 for boiler size setting instructions.

### D. Help Screen Diagnostic Features

Indication	Possible Cause								
<div style="border: 1px solid black; padding: 5px;">                     Lockout History 1 of 5 <span style="float: right;">✕</span> <table style="width: 100%; border-collapse: collapse;"> <tr> <td style="width: 30%;">Lockout</td> <td style="border: 1px solid black; text-align: center;">21</td> </tr> <tr> <td>Status</td> <td style="border: 1px solid black; text-align: center;">Safe Startup</td> </tr> <tr> <td>Run Time Hr</td> <td style="border: 1px solid black; text-align: center;">0</td> </tr> <tr> <td colspan="2" style="text-align: center; border: 1px solid black;">Detail</td> </tr> </table> </div>	Lockout	21	Status	Safe Startup	Run Time Hr	0	Detail		Lockout History is stored in a first-in, first-out basis. Each History file is stored with boiler run hour of when the lockout occurred. The "When happened" and "Current" provide: <ul style="list-style-type: none"> <li>- "Current" is the run hour and status the boiler just finished.</li> <li>- "When happened" is the run hour and status when the lockout occurred.</li> </ul>
Lockout	21								
Status	Safe Startup								
Run Time Hr	0								
Detail									
<div style="border: 1px solid black; padding: 5px;">                     For Service Contact: <span style="float: right;">✕</span>                     CONTRACTOR NAME                      CONTRACTOR ADDRESS 1                      CONTRACTOR ADDRESS 2                      PHONE NUMBER                 </div>	The user is given the contact information of the responsible service provider. Refer to page 116 for data entry instructions.								

## XV. Troubleshooting (continued)

### E. Active Fault Screen Faults

Indication	Condition	Possible Cause
<p>Limit String Status</p> 	Limit String Fault	<p>The Limit String Status screen shows the safety limit status. A contact icon, either “open” or “closed”, graphically represents each safety limit. The “closed” contact icon is steady; the “open” contact icon is blinking. For example, the screen shown to the left illustrates a “closed” external limit contact and an “open” LWCO contact.</p> <p>NOTE: Since the limit string items are wired in series, all limits downstream of the “open” limit will also appear on the screen as “open” (blinking) icons regardless of whether or not they are actually open. The Air Proving Switch is wired independent to all other limits. The Air Proving Switch is only required to be closed during boiler pre-purge. It is normal for it to be open during run mode.</p>
<p>Sensor Status</p> 	Sensor Fault	<p>The Sensor Status screen shows the status of all sensors. Possible states include:</p> <p>None: Feature requiring this sensor has not been selected.          Normal: Sensor is working normally.          Shorted: Sensor is shorted or is defective.          Open: There is a break in the wiring between the Control and the sensor or the sensor is defective</p> <p>Out of Range: Sensor is defective or is being subjected to electrical noise.          Unreliable: Sensor is defective or is being subjected to electrical noise.</p> <p>When a sensor fails “opened” or “shorted” the value is changed to reverse video (background black and value white) “024” or “768” respectively to indicate that there is a fault with the sensor.</p>
<p>Rate Limit</p> 	Rate Limit	<p>The following messages appear when the firing rate is limited or reduced to help avoid a lockout or save energy.</p> <p>Refer to Hard Lockout section for corrective actions</p> <ul style="list-style-type: none"> <li>- High Stack Temperature Limit</li> <li>- High Supply Temperature Limit</li> <li>- High Differential Temperature Limit</li> </ul> <p>The following messages appear as part of normal start and stop sequences:</p> <ul style="list-style-type: none"> <li>- Minimum Modulation (normal start/stop sequence)</li> <li>- Low Fire Hold Rate: Low fire hold rate is a normal start-up rate hold used to help ensure system temperature feedback prior to release to modulation. Low Fire Hold Time may be adjusted. Refer to the “Changing Adjustable Parameters”, Paragraph F, for additional information.</li> <li>- Maximum Expected Heat Rate: Maximum Expected Heat Rate limit is a normal start-up rate hold used to save energy. This limit helps reduce extra cycles and save energy. Boiler is free to modulate up to the sum of the active zones and domestic hot water expected heat rates. Each zone heat rate is adjustable and may be modified under the modulation menu. Refer to the “Changing Adjustable Parameters”, Paragraph F, for additional information.</li> </ul>
<p>EMS Status</p> 	Energy Management System Fault	<p>The Energy Management System (EMS) fault screen provides input fault status. When an input is shown as “Not Selected” it is not required for this application or has not yet been selected. These options are selected under the “Energy Management” Adjust mode menu.</p> <p>Modbus Input Failure    If a modbus input is selected and out of range or not present a “535” value is shown reverse video (background black and value white). To fix the problem check the input source and check that the input is properly connected.</p> <p>4-20mA Input Failure    4-20mA input not used in this application.</p>

## XV. Troubleshooting (continued)

**F. Troubleshooting problems where a Soft Lockout Code is displayed.** When a soft lockout occurs, the boiler will shut down and the “Help” button will “blink”. Select the “blinking” “Help” button to determine the cause of the soft lockout. The boiler will automatically restart once the condition that caused the lockout is corrected.

### Soft Lockout Codes Displayed

Lockout Number	Condition	Possible Cause
2 Boiler Safety Limit Open	Boiler Safety Limit wired to terminals J6-1 or 3 OPEN: <ul style="list-style-type: none"> <li>External Limit.</li> <li>Optional LWCO</li> </ul>	External Limit: <ul style="list-style-type: none"> <li>Water temperature is higher than External Limit setting. See “Hard Lockout 4” for additional information.</li> <li>External device not used and jumper not installed.</li> <li>External Limit device is defective.</li> <li>Loose wiring to limit device</li> </ul> Optional Low Water Cut Off (LWCO) <ul style="list-style-type: none"> <li>If yellow light on LWCO is on, system is low on water. Ensure air vent is unobstructed and properly functioning as a blocked air vent can result in low water indication.</li> <li>If neither yellow or green light on LWCO is on, check LWCO harness.</li> </ul>
3 Boiler Safety Limit Open	Blocked Flue/Inlet Switch wired to terminals J5-1 OPEN	<ul style="list-style-type: none"> <li>Blocked Flue/Inlet Switch contact open - check for blocked flue/air intake.</li> </ul> <p style="text-align: center;">NOTE Blocked Flue/Inlet Switch Special Note</p> <p>Before a call for heat the air pressure switch is closed. When there is a call for heat with a blocked vent the air pressure switch will open (due to excessive pressure of the blower against a blocked flue pipe) after the blower starts. The control stops the start sequence and stops the blower. After the blower stops the pressure switch re-closes and the cycle continues. The displays shows the cause of trip for only the time the pressure switch is open.</p>
7 Return sensor (10 KOHms) fault	Shorted or open return temperature sensor.	<ul style="list-style-type: none"> <li>Shorted or mis-wired return sensor wiring.</li> <li>Defective return sensor.</li> </ul>
8 Supply sensor (10 KOHms) fault	Shorted or open supply temperature sensor.	<ul style="list-style-type: none"> <li>Shorted or mis-wired supply sensor wiring.</li> <li>Defective supply sensor.</li> </ul>
9 DHW sensor (12 KOHms) fault	Shorted or open DHW sensor.	<ul style="list-style-type: none"> <li>Shorted or mis-wired DHW sensor wiring.</li> <li>Defective DHW sensor.</li> </ul>
10 Stack sensor (10 KOHms) fault	Shorted or open flue gas (stack) temperature sensor.	<ul style="list-style-type: none"> <li>Shorted or mis-wired flue temperature sensor wiring.</li> <li>Defective flue temperature sensor.</li> </ul>
11 Ignition failure	Flame failure after 5 tries to restart. Flame rod not detecting flame. <ul style="list-style-type: none"> <li>Condensate trap plugged.</li> </ul>	<ul style="list-style-type: none"> <li>No gas pressure.</li> <li>Gas pressure under minimum value shown on rating plate.</li> <li>Gas line not completely purged of air.</li> <li>Gas valve rectifier switch off.</li> <li>Defective Electrode.</li> <li>Loose burner ground connection.</li> <li>Defective Ignition Cable.</li> <li>Defective gas valve (check for 24 Vac at harness during trial for ignition before replacing valve).</li> <li>Air-fuel mixture out of adjustment - consult factory.</li> <li>Defective or fouled electrode.</li> <li>Plugged drain line in trap.</li> </ul>



## XV. Troubleshooting (continued)

### Soft Lockout Codes Displayed (continued)

Lockout Number	Condition	Possible Cause
13 Flame rod shorted to ground	<ul style="list-style-type: none"> <li>Flame rod shorted to ground</li> <li>Condensate Trap plugged.</li> </ul>	<ul style="list-style-type: none"> <li>Shorted or mis-wired flame rode wiring.</li> <li>Defective flame rod.</li> <li>Plugged drain line in trap.</li> </ul>
14 Differential Temperature inlet/outlet high	Temperature rise between supply and return is too high.	<ul style="list-style-type: none"> <li>Inadequate boiler water flow. Verify that circulator is operating and that circulator and piping are sized per Water Piping and Trim Section of this manual.</li> </ul>
15 Return temp higher than supply	The Control is reading a return sensor temperature higher than the supply sensor temperature. Condition must be present for at least 75 seconds for this error code to appear.	<ul style="list-style-type: none"> <li>Flow through boiler reversed. Verify correct piping and circulator orientation.</li> <li>No boiler water flow. Verify that system is purged of air and that appropriate valves are open.</li> <li>Supply or return sensor defective.</li> </ul>
16 Supply temp has risen too quickly	Supply water temperature has risen too quickly.	<ul style="list-style-type: none"> <li>See possible causes for "Hard Lockout 4".</li> <li>Inadequate boiler water flow.</li> <li>Verify that circulator is operating and that circulator and piping are sized per Water Piping and Trim Section of this manual.</li> </ul>
17 Normal waiting for blower speed to match purge and light-off setpoint.	Normal waiting for blower speed to match purge and light-off setpoint.	
27 Undefined Fault	Undefined Fault	<ul style="list-style-type: none"> <li>Consult Factory.</li> </ul>
28 or 53 Air Proving Switch Failed to Close	Air Proving Switch Failed to Close	<p>The air proving switch has failed to close;</p> <ul style="list-style-type: none"> <li>Check switch, check switch connection and wiring.</li> <li>Blocked vent, blocked inlet, blocked or disconnected air switch tube, blocked heat exchanger or burner.</li> <li>Something is blocking air/flue gas flow through boiler</li> </ul>
54 Air Proving Switch Failed to Open	Air Proving Switch Failed to Open	<p>The air proving switch has failed closed, check switch is operating properly. The air proving switch is "Closed" when it should be "Open". The air proving switch is checked for proper function before the blower is started and the start sequence is allowed to continue. If the air switch is closed before the blower is started (when there is no air flow) first a soft lockout is initiated and then a manual reset hard lockout results. The possible cause of the air proving switch to be closed or fail to open is as follows:</p> <ul style="list-style-type: none"> <li>The air proving switch is jumpered.</li> <li>The air proving switch is defective.</li> <li>The blower is running before the start sequence starts the blower. This can be caused by a loss of communication between the blower and Control. The blower goes to high speed when there is no communication between the Control and the blower. Possible cause of loss of communication is a defective wiring harness, blower or Control.</li> </ul>

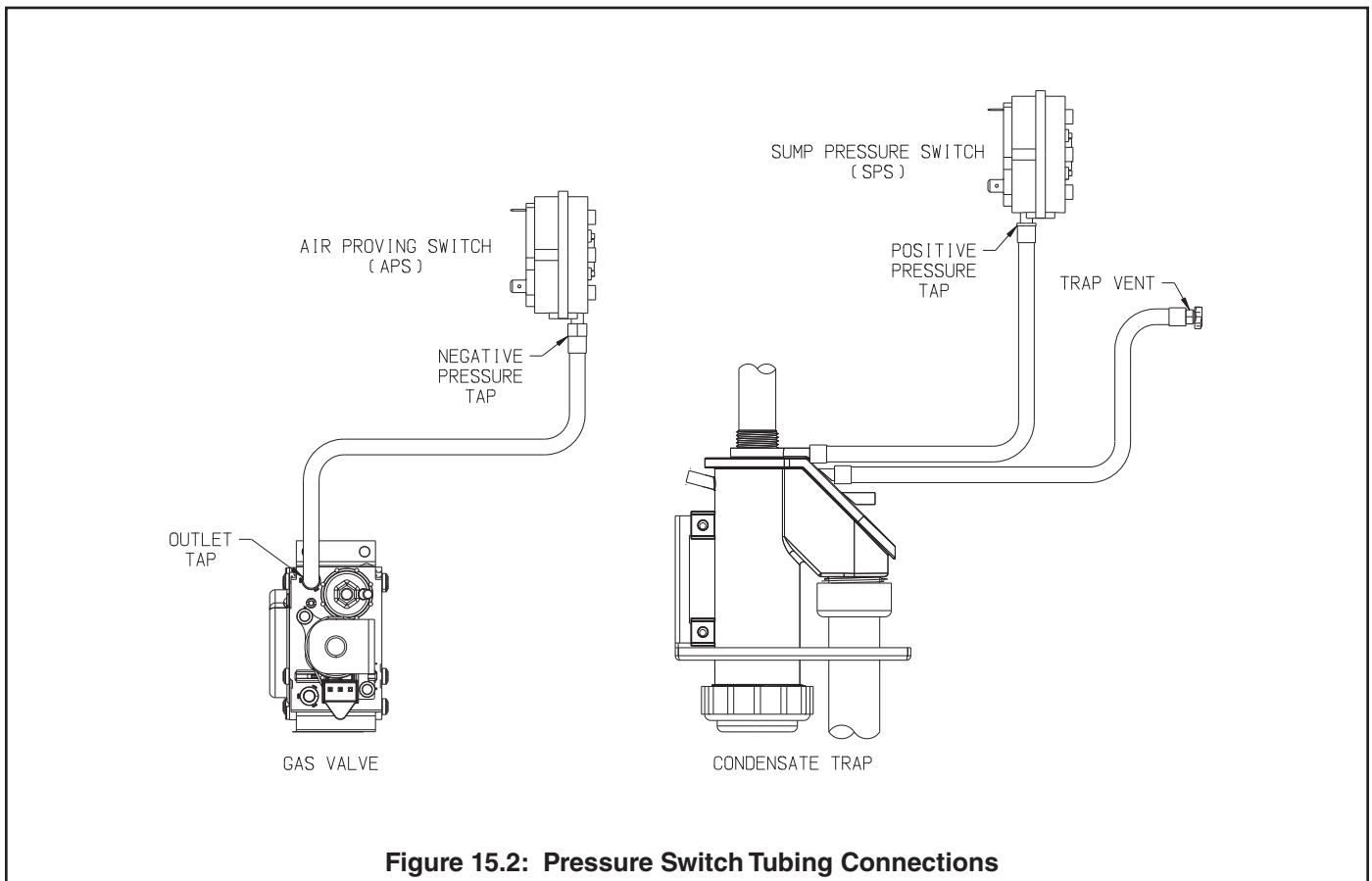
## XV. Troubleshooting (continued)

**G. Troubleshooting problems where a Hard Lockout Code is displayed.** When a hard lockout occurs, the boiler will shut down, the display will turn red and the “Help” button will “blink”. Select the “blinking” “Help” button to determine the cause of the Hard Lockout. Once the condition that caused the lockout is corrected, the boiler will need to be manually reset using the Reset button on the “Active Fault” display or located on the Control.

### Hard Lockout Codes Displayed

Lockout Number	Condition	Possible Cause
4 Supply High Limit	Control supply sensor detected temperatures in excess of 210°F.	<ul style="list-style-type: none"> <li>Heating load at time of error was far below the minimum firing rate of the boiler.</li> <li>Defective system circulator or no flow in primary loop.</li> <li>Defective boiler circulator, no flow or insufficient flow in boiler loop.</li> <li>Control system miswired so that the boiler operation is permitted when no zones are calling.</li> </ul>
6 Stack High Limit	Control Flue gas (Stack) sensor detected temperatures in excess of 214°F (101°C).	<ul style="list-style-type: none"> <li>Heat exchanger needs to be cleaned.</li> <li>Boiler over-fired.</li> <li>Air-fuel mixture out of adjustment - consult factory.</li> </ul>
12 Flame detected out of sequence	A flame signal was present when there should be no flame. <ul style="list-style-type: none"> <li>Condensate trap plugged.</li> </ul>	<ul style="list-style-type: none"> <li>Defective gas valve - make sure inlet pressure is below maximum on rating plate before replacing valve.</li> <li>Plugged drain line in trap.</li> </ul>
18 Light off rate proving failed	Blower is not running at Light-off rate when it should or blower speed signal not being detected by Control.	<ul style="list-style-type: none"> <li>Loose connection in 120 VAC blower wiring.</li> <li>Loose or miswired blower speed harness.</li> <li>Defective blower</li> </ul>
19 Purge rate proving failed	Blower is not running at Purge rate when it should or blower speed signal not being detected by Control.	<ul style="list-style-type: none"> <li>Loose connection in 120 VAC blower wiring.</li> <li>Loose or miswired blower speed harness.</li> <li>Defective blower</li> </ul>
20 Invalid Safety Parameters	Unacceptable Control Safety related parameter detected.	Safety Parameter verification required. Contact factory.
21 Invalid Modulation Parameter	Unacceptable Control Modulation related parameter detected.	Reset the control.
22 Safety data verification needed	Safety related parameter change has been detected and a verification has not been completed.	Safety related Control parameter has been changed and verification has not been performed.
23 24VAC Voltage low/high	Control 24Vac control power is high or low.	<ul style="list-style-type: none"> <li>Loose connection in 24Vac VAC power wiring.</li> <li>Loose or miswired 24Vac harness.</li> <li>Miswired wiring harness causing power supply short to ground.</li> <li>Defective transformer.</li> <li>Transformer frequency, voltage and VA do not meet specifications.</li> </ul>
24 Fuel Valve Error	Power detected at fuel valve output when fuel valve should be off.	Reset the control. If problem reoccurs, replace the Control.
25 Hardware Fault	Internal control failure.	Reset the control. If problem reoccurs, replace the Control.
26 Internal Fault	Internal control failure.	Reset the control. If problem reoccurs, replace the Control.
27 Undefined Fault	Undefined Fault	Reset the Control. If problem reoccurs, replace the Control.
54 Air Proving Switch Failed to Open	Air Proving Switch Failed to Open	See Soft Lockout 54.

## XV. Troubleshooting (continued)



**Table 15.3a: Supply, Return and Flue Temperature Sensor Temperature versus Resistance**

Temperature		Ohms of Resistance
°F	°C	
32	0	32624
50	10	19897
68	20	12493
77	25	10000
86	30	8056
104	40	5324
122	50	3599
140	60	2483
158	70	1748
176	80	1252
194	90	912
212	100	674
230	110	506
248	120	384

**Table 15.3b: Outdoor Air Temperature Sensor Temperature versus Resistance**

Outdoor Temperature		Ohms of Resistance
°F	°C	
-20	-28.9	106926
-10	-23.3	80485
0	-17.8	61246
10	-12.2	47092
20	-6.7	36519
30	-1.1	28558
40	4.4	22537
50	10.0	17926
60	15.6	14356
70	21.1	11578
76	24.4	10210
78	25.6	9795
80	26.7	9398
90	32.2	7672
100	37.8	6301
110	43.3	5203
120	48.9	4317

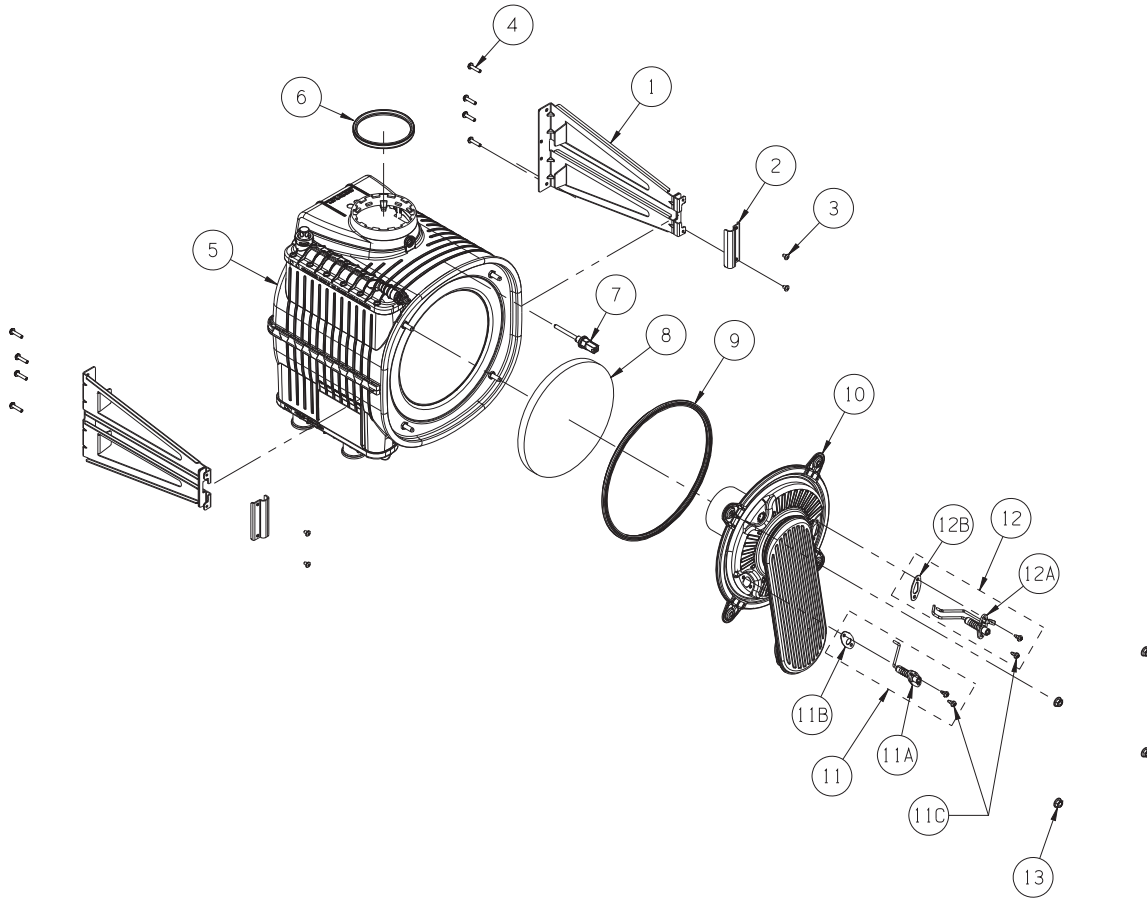
## XV. Troubleshooting (continued)

**Table 15.3c: DHW Temperature Sensor  
Temperature versus Resistance**

Temperature		Ohms of Resistance
°F	°C	
32	0	36129
35	1.7	33622
40	4.4	29443
45	7.2	26028
50	10.0	22804
55	12.8	20301
60	15.6	17906
65	18.3	15948
68	20.0	14773
70	21.1	14157
75	23.9	12616
77	25.0	12000
80	26.7	11268
85	29.4	10048
86	30.0	9804
90	32.2	9026
95	35.0	8054
100	37.8	7275
104	40.0	6652
105	40.6	6526
110	43.3	5899
115	46.1	5319
120	48.9	4810
122	50.0	4607
125	51.7	4359
130	54.4	3945
135	57.2	3591
140	60.0	3252

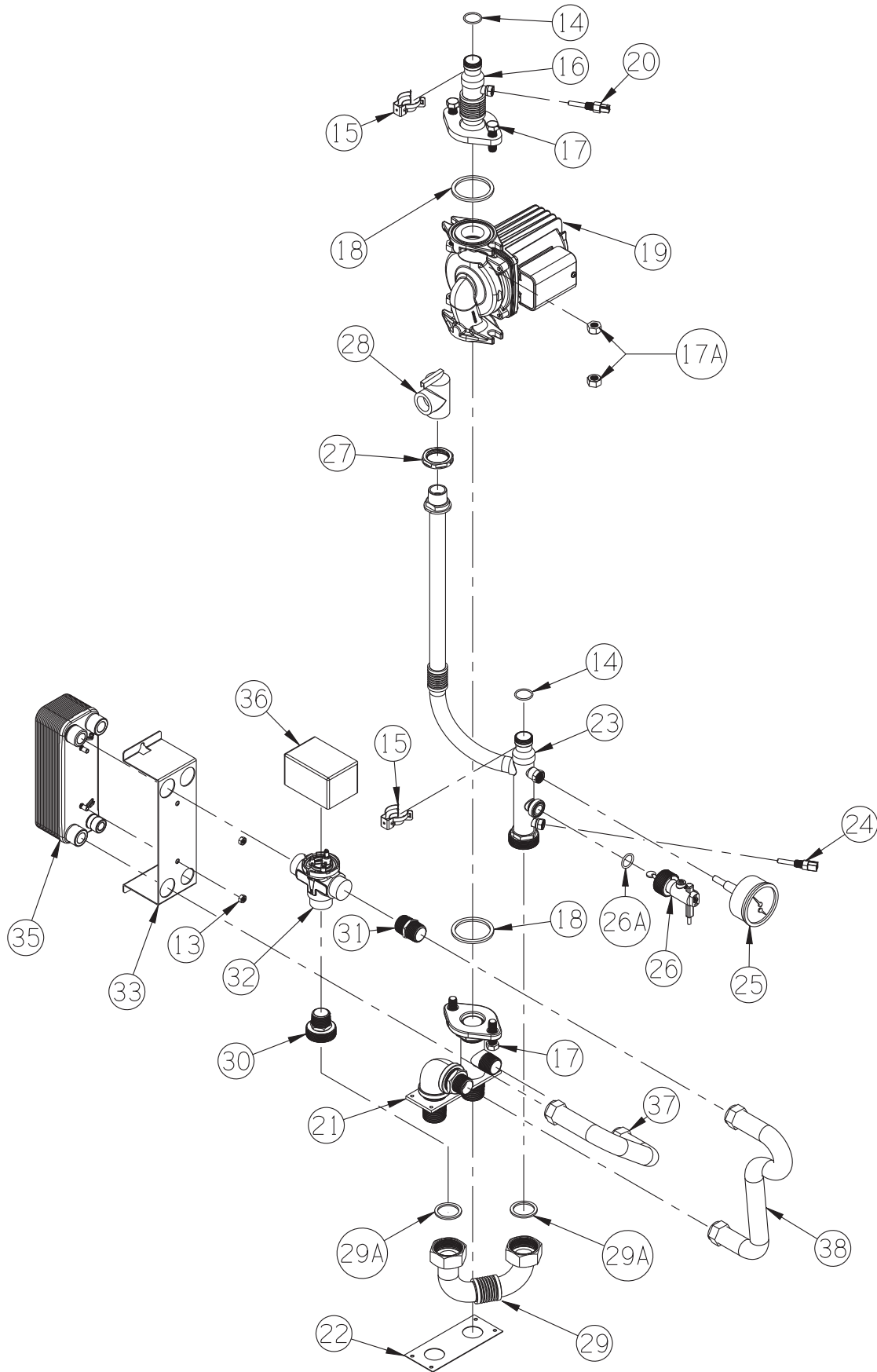
## XVI. Repair Parts

All K2WTC Series Repair Parts may be obtained through your local U.S. Boiler Wholesale distributor. Should you require assistance in locating a U.S. Boiler distributor in your area, or have questions regarding the availability of U.S. Boiler products or repair parts, please contact U.S. Boiler Customer Service at (717) 481-8400 or Fax (717) 481-8408.



Key No.	Description	Part Number		
		135	150	180
1	Fixing Clamp Bracket	Contact U.S. Boiler Company; Provide boiler serial number		
2	Holding Clamp			
3	M4 x 7 Fixing Clamp Screw			
4	10 -32 x 1/2" Thread Cutting Screw			
5	Bare Heat Exchanger			
6	Flue Outlet Gasket	105882-01		
7	Flue Temperature Sensor	105883-01		
8	Rear Target Wall Insulation	105651-01		
9	Cold Burner Door Black Outer Gasket	106030-01		
10	Cold Burner Door Assembly	108302-01	108303-01	
11A, 11B, 11C	Flame Rod (includes flame rod, gasket and hardware)	105880-01		
12A, 12B, 12C	Ignition Electrode (includes electrode, gasket and hardware)	105881-02		
13	M6 Serrated Flange Hex Nut	Obtain locally		

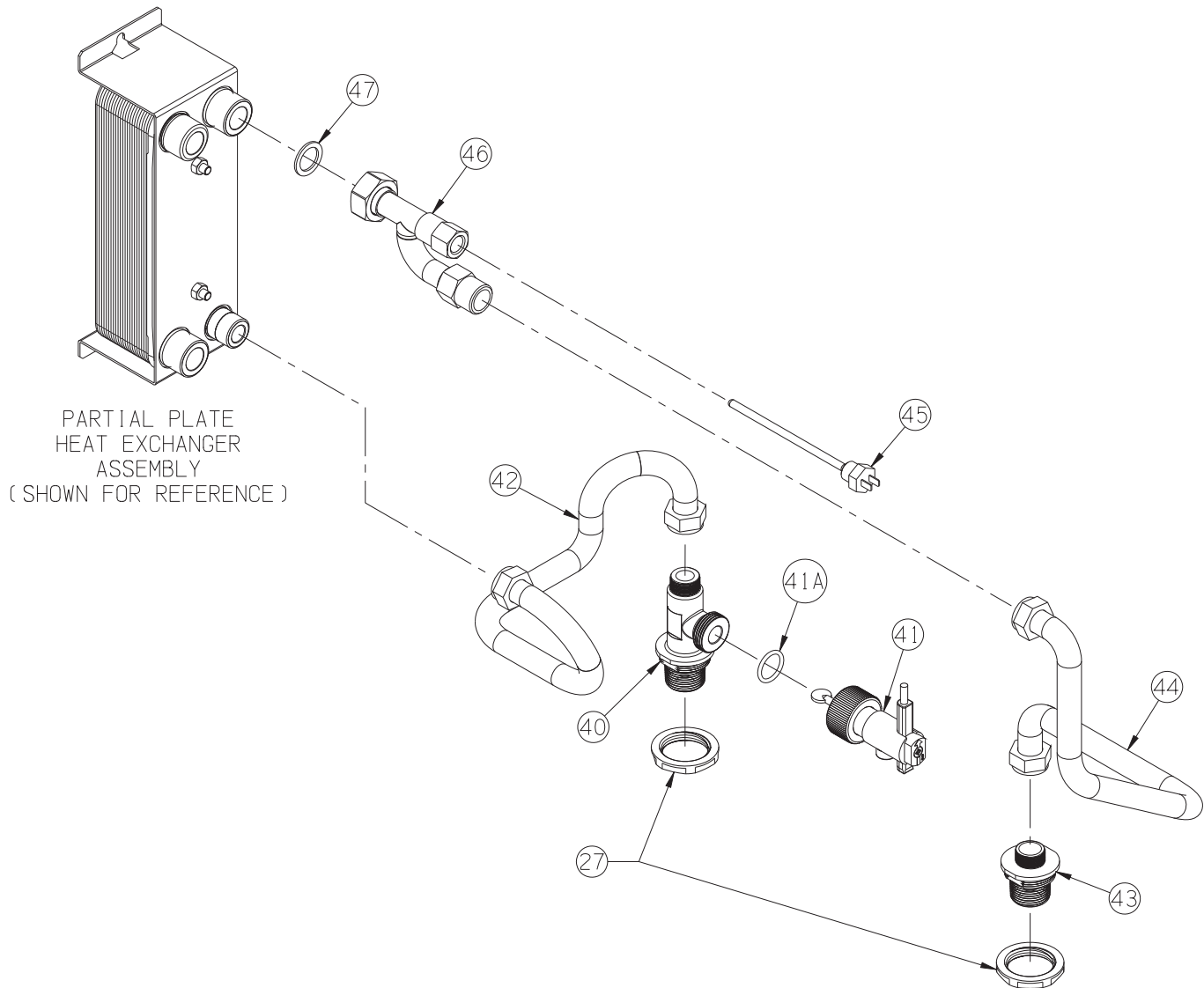
XVI. Repair Parts (continued)



## XVI. Repair Parts (continued)

Key No.	Description	Part Number		
		135	150	180
14, 15, 18, 29A	Boiler Water Gasket Repair Kit (includes (2) 22mm x 2mm O-rings, (2) connection clips, (2) 1-1/4 Union Gaskets, and (2) Pump Gaskets)	108191-01		
16, 17, 17A	Return Pipe Repair Kit (includes return piping assembly and flange hardware)	108211-01		
19	Boiler Circulator	Obtain Locally		
20	Return Temperature Sensor	105910-01		
21, 17, 17A, 22	Piping Block Kit	108209-01	108210-01	
23, 27	Supply Pipe Repair Kit (includes supply piping assembly and locknut)	108212-01		
24	Supply Temperature Sensor	105911-01		
25	T&P Gauge	108215-01		
26, 26A	Boiler Supply Flow Switch & O-Ring	105892-01		
28	30 psi Relief Valve	81660319		
29	Supply "U" Bend	108213-01	108214-01	
13, 29A, 33, 35, 47	Plate HX (includes mounting bracket, hardware, and fiber gasket)	108204-01		
29A, 30, 31, 32, 47	Valve Body Repair Kit (includes fittings for both 135 and 150/180)	108187-01		
36	Valve Actuator	108186-01		
37, 38	Boiler Water CSST set	108189-01	108190-01	

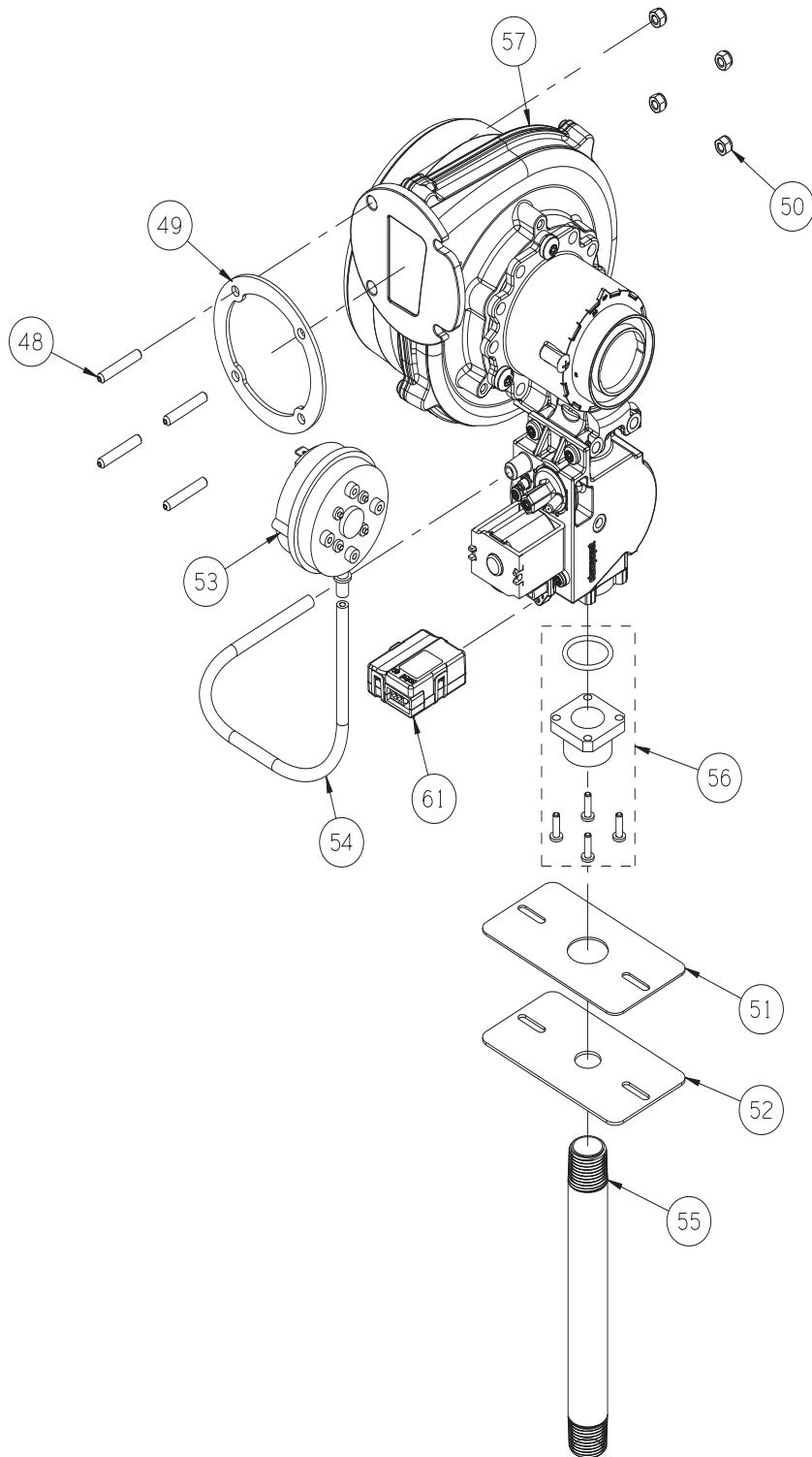
## XVI. Repair Parts (continued)



Key No.	Description	Part Number		
		135	150	180
40, 43, 27, 46, 47	DHW Fitting Set	108197-01		
41, 41A	DHW Flow Switch	108155-01		
42, 44	DHW CSST Set	108196-01		
45	DHW Temperature Sensor	108154-01		



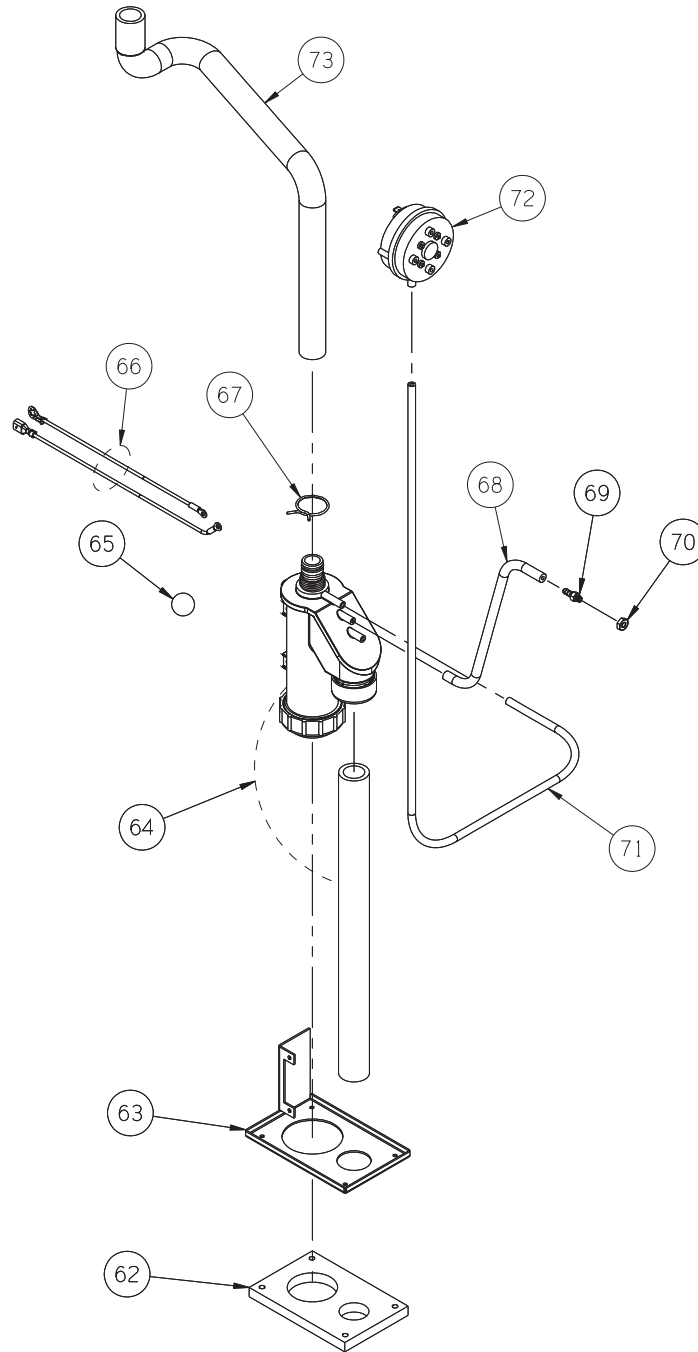
## XVI. Repair Parts (continued)



## XVI. Repair Parts (continued)

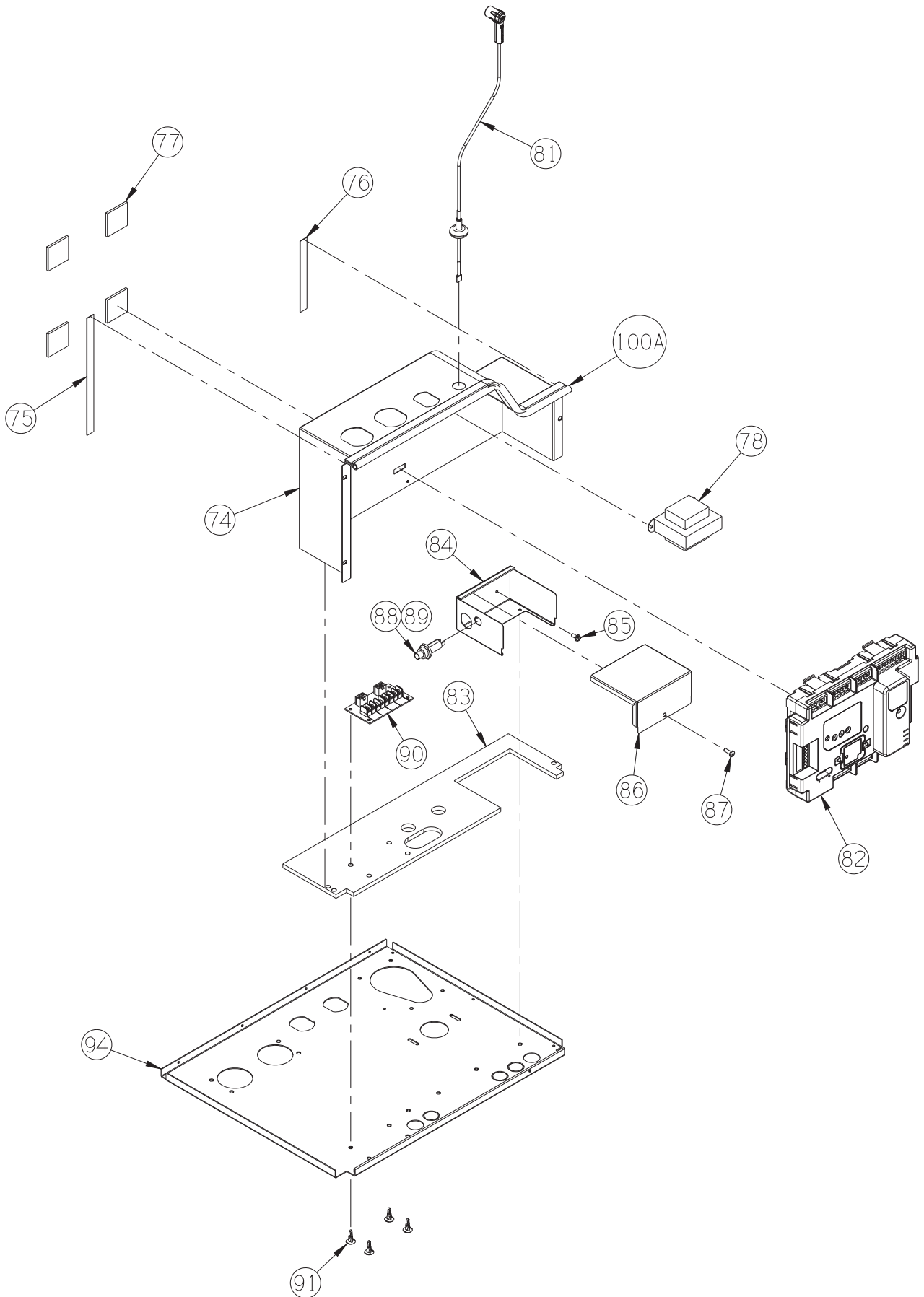
Key No.	Description	Part Number		
		135	150	180
48, 49, 50, 57	Gas Train Assembly, Natural Gas (excludes "M" models)	107866-01		107867-01
48, 49, 50, 57	Gas Train Assembly, LP Gas (excludes "M" models)	107870-01		107871-01
Not Shown	LP Gas Conversion Kit (excludes "M" models)	107874-01		107875-01
48, 49, 50	Blower Outlet Gasket	106029-01		
51, 52	Gas Line Seal (includes gas line escutcheon plate, gasket and hardware)	107898-01		
53	Air Proving Pressure Switch	107861-01	107862-01	
54, 67, 68, 69, 70, 71, 73	Tubing Repair Kit	108218-01		
55	1/2" NPT x 7" Steel Nipple	Obtain locally		
56	Gas Valve Flange	107901-01		
61	Rectifier Module (excludes "M" models)	105829-01		
Not Shown	Vent Side Noise Attenuator	107680-01	107681-01	

**XVI. Repair Parts (continued)**



Key No.	Description	Part Number		
		135	150	180
62, 63, 64	Condensate Trap (includes gasket, bracket and trap ball)	105851-01		
65	Ball for Condensate Trap	105850-01		
66	Trap Harness Kit	107159-01		
54, 67, 68, 69, 70, 71, 73	Tubing Repair Kit	108218-01		
72	Sump Pressure Switch	107878-01		

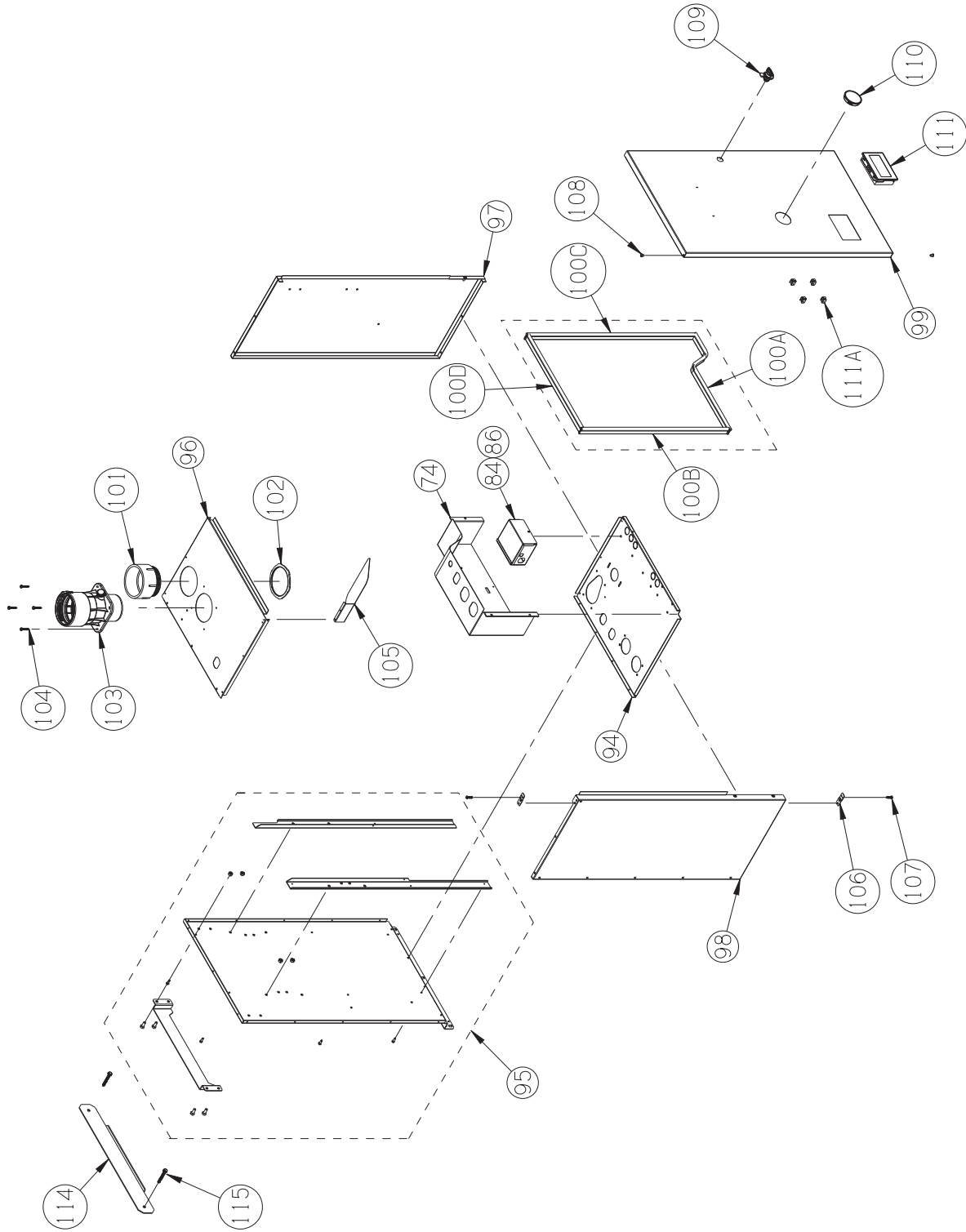
XVI. Repair Parts (continued)



## XVI. Repair Parts (continued)

Key No.	Description	Part Number		
		135	150	180
22, 52, 62, 75, 76, 77, 83, 100A, 100B, 100C, 100D	Air Gasket Replacement Kit		108188-01	
78	Transformer		106034-01	
81	Ignition Cable		107152-01	
82	Boiler Control (2.3)		107877-01	
84, 85, 86, 87, 88, 89, 120, 121	J-Box Replacement Kit		108207-01	
90, 91	Low Voltage Printed Circuit Board (includes low voltage PCB and hardware)		107141-01	
74, 75, 76, 77, 100A	Control Box (includes gaskets and hardware)		108194-01	

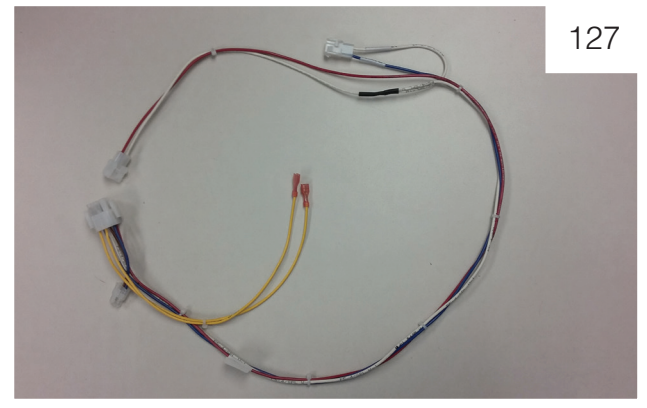
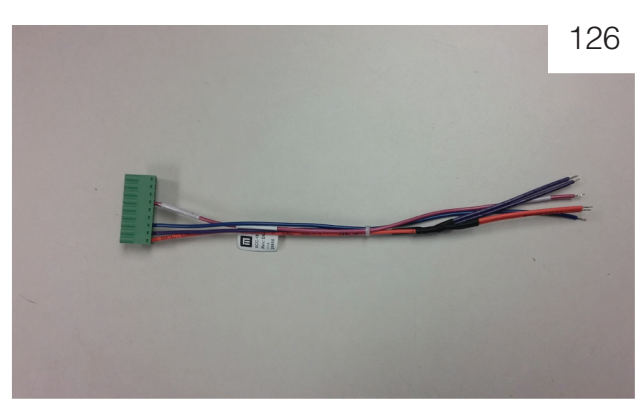
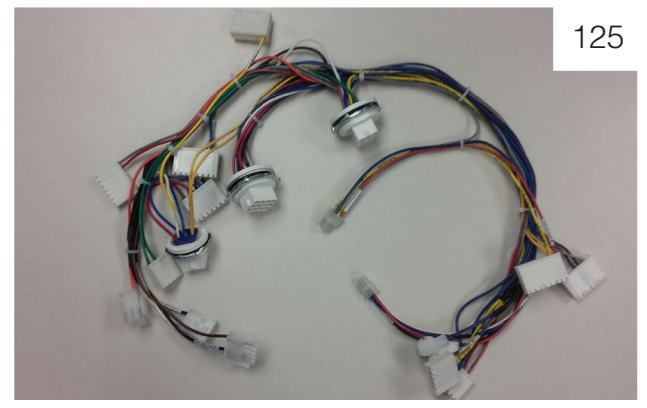
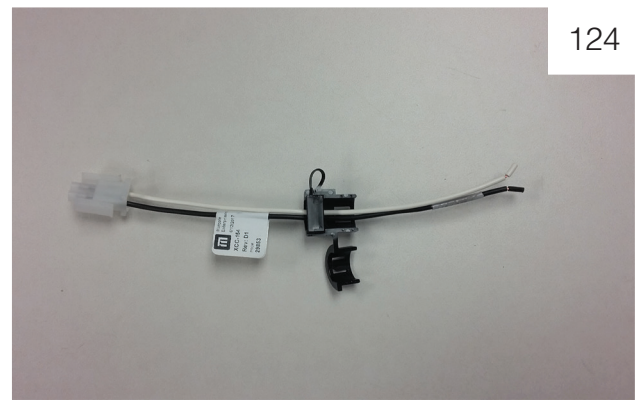
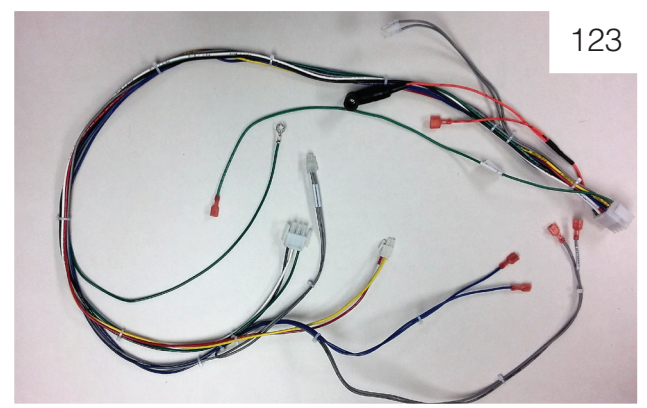
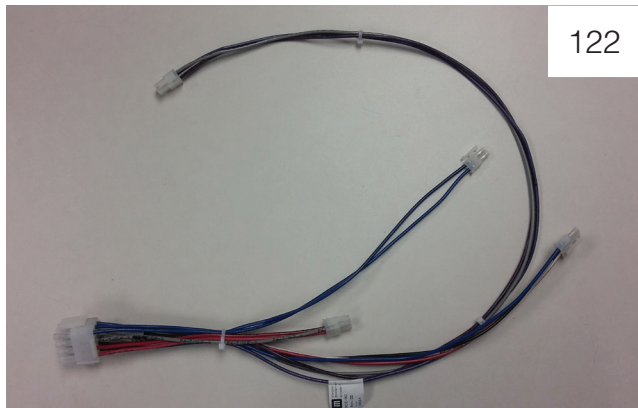
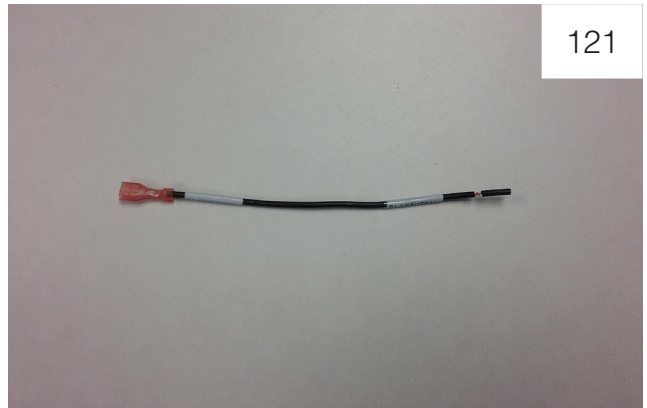
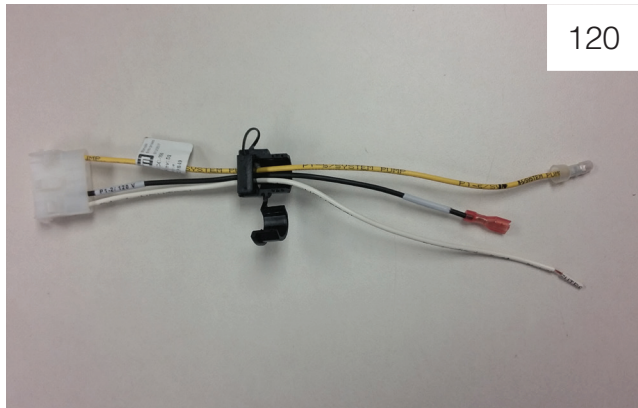
XVI. Repair Parts (continued)



## XVI. Repair Parts (continued)

Key No.	Description	Part Number (Qty)		
		135	150	180
96, 97, 98, 100B, 100C, 100D	Top/Side Panel Set (includes gaskets)	108216-01	108217-01	
99	K2WTC Replacement Door	108202-01		
101, 102	Intake Repair Kit	105848-01		
103, 104	Vent Connector (includes connector, gasket, and hardware)	107034-01		
106, 107, 108, 109, 110	Front Door Hardware	108200-01		
111, 111A, 126	Display Assembly	108198-01		
114	Wall Mounting Bracket	102989-01		
115	5/16" X 2" Lag Screw/Washer	Obtain locally		

XVI. Repair Parts (continued)





**XVI. Repair Parts (continued)**

Key No.	Description	Part Number		
		135	150	180
120, 121	J-Box Harness Set	108208-01		
122	Internal DC Harness	108206-01		
123	Internal AC Harness	108205-01		
124	Circ-Zone Valve Harness (3 req'd per boiler)	108192-01		
125	Control Box Harness	108195-01		
126	Display Harness	108199-01		
127	Combi Wire Harness	108193-01		
Not Shown	Outdoor Temperature Sensor	102946-01		

---

## Appendix A: Instructions for High Altitude Installations Above 2000 ft.

---



### WARNING

Do not attempt to install K2WTC-180B at altitudes above 2000ft. Attempts to do so may result in unreliable operation, property damage, personal injury or loss of life due to carbon monoxide (CO) poisoning.

These instructions apply only to the following K2WTC boiler configurations: **2001 ft.- 6000 ft, 6000 ft.- 7800 ft., 7801 ft.- 10,100 ft.**

These instructions contain specific information to setup your boiler to ensure proper operation.



### WARNING

**LP Conversions - K2WTC boiler setup from factory is configured for use with natural gas installed from 0 - 2000 ft above sea level only. For any conversion to LP, use a proper conversion kit per Table 3.1. Use a combustion analyzer and follow all instructions supplied with conversion kit. If the instructions are not followed exactly, a fire, an explosion or production of carbon monoxide may result causing property damage, personal injury or loss of life. The qualified service agency is responsible for proper installation of this boiler for use with LP gas. The installation is not proper and complete until the operation of the converted appliance is checked as specified in the manufacturer's instructions supplied.**

**These instructions include a procedure for adjusting the air-fuel mixture on this boiler. This procedure requires a combustion analyzer to measure the CO<sub>2</sub> (or Oxygen) and Carbon Monoxide (CO) levels in flue gas. Adjusting the air-fuel mixture without a proper combustion analyzer could result in unreliable boiler operation, personal injury, or death due to carbon monoxide poisoning.**

**Failure to setup the Boiler in accordance with these instructions could result in high amount of Carbon Monoxide to be produced which could result in death, serious injury, and/or reduced component life.**

**NOTICE** This boiler comes with a vent side noise attenuator. If equivalent vent length is less than 70 equivalent ft., install vent side noise attenuator as described in the venting section of this manual. Failure to do so may result in boiler combustion noise during operation. Attenuator is not required on size 135 at altitudes above 2000ft.

### Adjusting Boiler Type (must be completed first)

Select the correct K2WTC boiler size, altitude, and fuel range using the touch screen display as follows:

1. Check boiler's rating label for actual boiler size.
2. Confirm installation altitude
3. Power up the boiler. The display will show the Home screen.
4. Press "Adjust" button on the Home screen.
5. Press "Adjust" button on the Adjust Mode screen.
6. Press "Login" button to access Password screen.
7. Press 5-digit display to open a keypad. **Enter the password "86"** and press the return arrow to close keypad. Press "Save" button.
8. Press "Adjust" button to enter Adjustment Mode.

9. Press "Modulation Setup" menu button.
10. Press "Adjust" button on the Boiler Type screen.
11. Use the ↓ ↑ arrow buttons to select the correct size, altitude, and fuel of your boiler. Press the (Check with Circle) button to enter your selection.
12. Press "Enter" button until display stops blinking, press next and repeat until "Completed" is displayed.
13. Press X to exit

### Basic Setup Procedure for K2WTC High Altitude Natural Gas

After Boiler Type has been selected, proceed to Section XI "Start-up and Checkout" to complete boiler setup. See Table A1 for altitude combustion values.

## Appendix A - (continued)

**Table A1: K2WTC Altitude Adjustments (Above 2000 ft. only)**

Model No.	Fuel	Measured %CO <sub>2</sub> *						Max. CO Air Free
		2001-6000 ft.		6001-7800 ft.		7801-10,100 ft.		
		Range	Target	Range	Target	Range	Target	
K2WTC-135B	NG	8.9-9.2	9.2	8.9-9.2	9.2	8.6-8.9	8.9	COAF readings must be less than 200ppm.
	LP	9.4-9.7	9.7	9.8-10.1	10.1	Not Permitted		
K2WTC-150B	NG	8.9-9.2	9.2	9.0-9.3	9.3	8.8-9.1	9.1	
	LP	9.5-9.8	9.8	9.5-9.8	9.8	9.5-9.8	9.8	
K2WTC-180B	NG	Not Permitted						
	LP							

\* Low Fire Range and Target values are the same as High Fire above. Ensure low fire CO<sub>2</sub> reading is less than or equal to high fire CO<sub>2</sub> reading.

Model No.	Fuel	Measured %O <sub>2</sub> **						Max Co Air Free
		2001-6000 ft.		6001-7800 ft.		7801-10,100 ft.		
		Range	Target	Range	Target	Range	Target	
K2WTC-135B	NG	4.7-5.3	4.7	4.7-5.3	4.7	5.3-5.8	5.3	COAF readings must be less than 200ppm.
	LP	6.2-6.6	6.2	5.6-6.0	5.6	Not Permitted		
K2WTC-150B	NG	4.7-5.3	4.7	4.6-5.0	4.6	4.9-5.4	4.9	
	LP	6.0-6.5	6.0	6.0-6.5	6.0	6.0-6.5	6.0	
K2WTC-180B	NG	Not Permitted						
	LP							

\*\* Low Fire Range and Target values are the same as High Fire above. Ensure low fire O<sub>2</sub> reading is greater than or equal to high fire O<sub>2</sub> reading.

## Appendix A - (continued)

**Table A2: K2WTC Altitudes Derates**

Model No.	Fuel	Approximate Derate per 1000 ft.		
		2001-6000 ft.	6001-7800 ft.	7801-10,100 ft.
K2WTC-135B	NG	1.2%	1.8%	2.4%
	LP	1.7%	3.3%	Not Permitted
K2WTC-150B	NG	2.6%	2.9%	3.1%
	LP	3.2%	3.0%	3.3%
K2WTC-180B	NG	Not Permitted		
	LP			

NOTE: THESE DERATES ARE AT MINIMUM VENT LENGTH Max. Vent Length 135 eq. Feet (3 inch Intake/Vent Pipe)

**Table A3: Approximate Starting Number of Throttle Turns**

Model Size	# Counter-clockwise Turns (From Fully Closed)	
	Natural Gas	LP Gas
135	12-1/4	9
150	10	10
180	15	14

## Appendix B: Special Requirements For Side-Wall Vented Appliances In The Commonwealth of Massachusetts

### IMPORTANT

The Commonwealth of Massachusetts requires compliance with regulation 248 CMR 4.00 and 5.00 for installation of side-wall vented gas appliances as follows:

(a) For all side wall horizontally vented gas fueled equipment installed in every dwelling, building or structure used in whole or in part for residential purposes, including those owned or operated by the Commonwealth and where the side wall exhaust vent termination is less than seven (7) ft. above finished grade in the area of the venting, including but not limited to decks and porches, the following requirements shall be satisfied:

1. **INSTALLATION OF CARBON MONOXIDE DETECTORS.** At the time of installation of the side wall horizontal vented gas fueled equipment, the installing plumber or gas fitter shall observe that a hard wired carbon monoxide detector with an alarm and battery back-up is installed on the floor level where the gas equipment is to be installed. In addition, the installing plumber or gas fitter shall observe that a battery operated or hard wired carbon monoxide detector with an alarm is installed on each additional level of the dwelling, building or structure served by the side wall horizontal vented gas fueled equipment. It shall be the responsibility of the property owner to secure the services of qualified licensed professionals for the installation of hard wired carbon monoxide detectors.

a. In the event that the side wall horizontally vented gas fueled equipment is installed in a crawl space or an attic, the hard wired carbon monoxide detector with alarm and battery back-up may be installed on the next adjacent floor level.

b. In the event that the requirements of this subdivision can not be met at the time of completion of installation, the owner shall have a period of thirty (30) days to comply with the above requirements; provided, however, that during said thirty (30) day period, a battery operated carbon monoxide detector with an alarm shall be installed.

2. **APPROVED CARBON MONOXIDE DETECTORS.** Each carbon monoxide detector as required in accordance with the above provisions shall comply with NFPA 720 and be ANSI/UL 2034 listed and IAS certified.

3. **SIGNAGE.** A metal or plastic identification plate shall be permanently mounted to the exterior of the building at a minimum height of eight (8) ft. above grade directly in line with the exhaust vent terminal for the horizontally vented gas fueled heating appliance or equipment. The sign shall read, in print size no less than one-half (1/2) inch in size, "GAS VENT DIRECTLY BELOW. KEEP CLEAR OF ALL OBSTRUCTIONS".

4. **INSPECTION.** The state or local gas inspector of the side wall horizontally vented gas fueled equipment shall not approve the installation unless, upon inspection, the inspector observes carbon monoxide detectors and signage installed in accordance with the provisions of 248 CMR 5.08(2)(a)1 through 4.

(b) **EXEMPTIONS:** The following equipment is exempt from 248 CMR 5.08(2)(a)1 through 4:

1. The equipment listed in Chapter 10 entitled "Equipment Not Required To Be Vented" in the most current edition of NFPA 54 as adopted by the Board; and

2. Product Approved side wall horizontally vented gas fueled equipment installed in a room or structure separate from the dwelling, building or structure used in whole or in part for residential purposes.

## Appendix B - (continued)

- (c) MANUFACTURER REQUIREMENTS - GAS EQUIPMENT VENTING SYSTEM PROVIDED. When the manufacturer of Product Approved side wall horizontally vented gas equipment provides a venting system design or venting system components with the equipment, the instructions provided by the manufacturer for installation of the equipment and the venting system shall include:
1. Detailed instructions for the installation of the venting system design or the venting system components; and
  2. A complete parts list for the venting system design or venting system.
- (d) MANUFACTURER REQUIREMENTS - GAS EQUIPMENT VENTING SYSTEM NOT PROVIDED. When the manufacturer of a Product Approved side wall horizontally vented gas fueled equipment does not provide the parts for venting the flue gases, but identifies "special venting systems", the following requirements shall be satisfied by the manufacturer:
1. The referenced "special venting system" instructions shall be included with the appliance or equipment installation instructions; and
  2. The "special venting systems" shall be Product Approved by the Board, and the instructions for that system shall include a parts list and detailed installation instructions.
- (e) A copy of all installation instructions for all Product Approved side wall horizontally vented gas fueled equipment, all venting instructions, all parts lists for venting instructions, and/or all venting design instructions shall remain with the appliance or equipment at the completion of the installation.



**U.S. Boiler Company, Inc.**  
**P.O. Box 3020**  
**Lancaster, PA 17604**  
**1-888-432-8887**  
**[www.usboiler.net](http://www.usboiler.net)**