

# Barcelona 2 Freestanding Bathtub

BA2-N-SW-NO / BA2-N-SW-OF / BA2M-N-SM-NO / BA2M-N-SM-OF

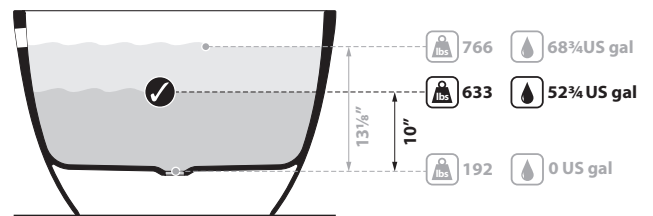
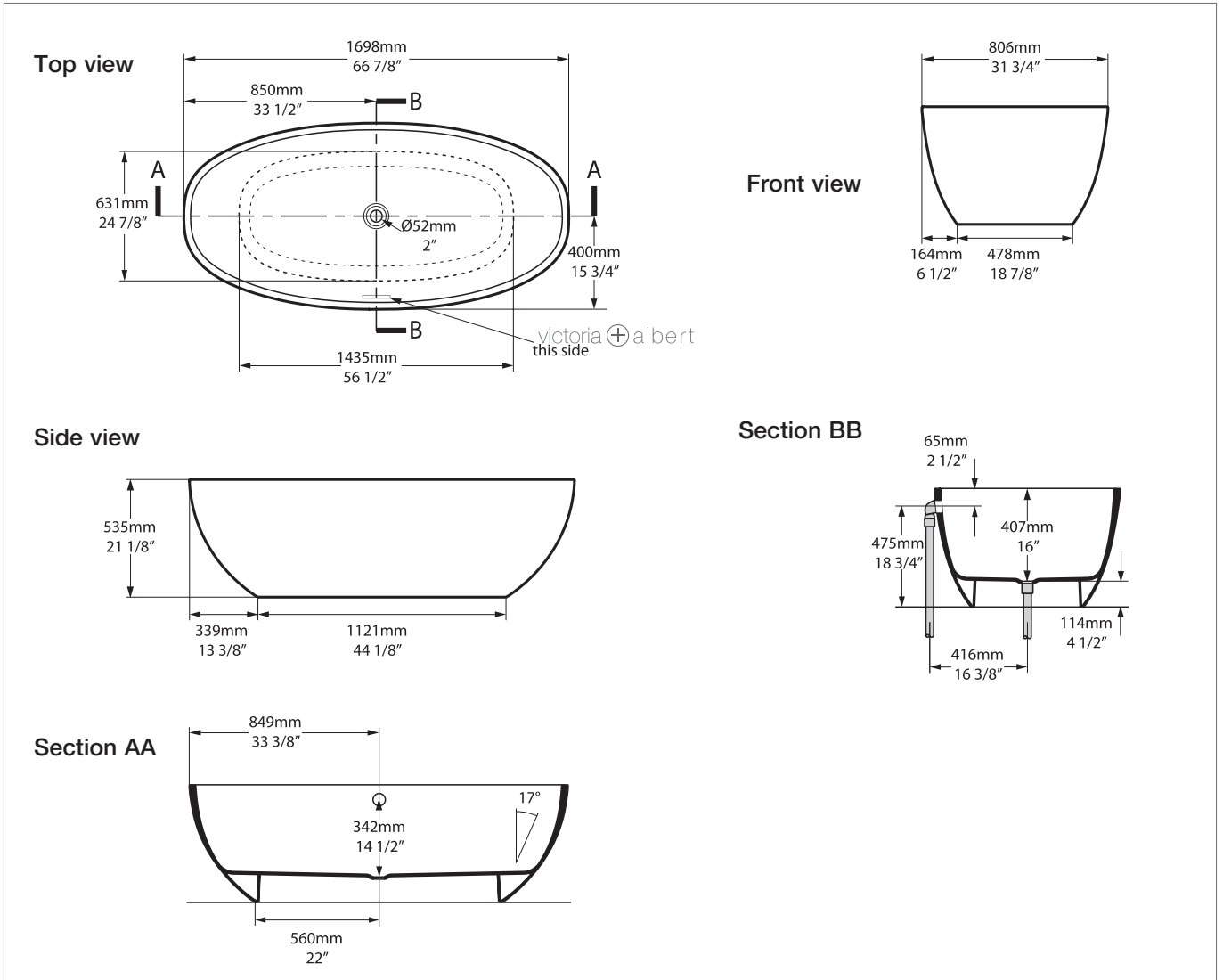

BV-2.1\_0029(A)

Recommended drains: K-36E-xx / K-70-xx / K-50-XX

• All measurements subject to +/-5% tolerance  
 NO = no overflow hole  
 OF = overflow hole

25 years

25 year warranty for residential use (unpainted product)  
 Garantie de 25 ans pour un utilisatio résidentiel (produit non peint)  
 Garantía de 25 años para uso domestico (productos no pintados)

5 years

5 year warranty on drains  
 Garantie de 5 ans sur les drains  
 Garantía de 5 años para los drenajes



Massachusetts Code: Approved  
 cJPC listing by IAPMO: File No. 6574



8 years

8 year warranty for commercial use (unpainted product)  
 Garantie de 8 ans pour un usage commercial (produit non peint)  
 Garantía de 8 años para uso comercial (productos no pintados)

2 years

2 year warranty on painted exterior  
 Pour les finitions extérieures peintes la garantie est de 2 ans  
 Acabados de pintura exterior tienen una garantía de 2 años