

# PROPANE & HIGH ALTITUDE CONVERSION INSTRUCTIONS

(FOR ALTITUDES OF 0-10,000 ft ONLY)

Applies to: Gas-Fired, Tubular Radiant,  
Low-Intensity Infrared Heater  
for generation codes ZZ & BB  
Models VPS, VPT, VCS, VCT



## FOR YOUR SAFETY

If you smell gas:

1. Open windows.
2. Don't touch electrical switches.
3. Extinguish any open flame.
4. Immediately call your gas supplier.

## FOR YOUR SAFETY

The use and storage of gasoline or other flammable vapors and liquids in open containers in the vicinity of this appliance is hazardous.

**WARNING:** Improper installation, adjustment, alteration, service, or maintenance can cause property damage, injury or death. Read the installation, operation, and maintenance instructions thoroughly before installing or servicing this equipment.

**WARNING:** Gas-fired appliances are not designed for use in hazardous atmospheres containing flammable vapors or combustible dust, in atmospheres containing chlorinated or halogenated hydrocarbons, or in applications with airborne silicone substances.

# INDEX

Section	Page
Section 1 Propane Conversion Kit Parts List/Technical Data -----	3
Section 2 Step by step conversion instructional data -----	16
Section 3 Burner Orifice Plate Replacement -----	18
Section 4 Turbulator information -----	18
Section 5 Flame Plate Attachment -----	19
Section 6 Gas Orifice Replacement -----	20
Section 7 Baffle Plate Installation -----	21
Section 8 Refitting Burner Head -----	22
Section 9 Gas Valve LP Conversion -----	22
Section 10 Fan Orifice Plate Replacement -----	24
Section 11 Data Badge Replacement -----	25
Section 12 Re-commissioning -----	26
Section 13 Orifice Pressure Adjustment and Heat Inputs by Altitude -----	27
Section 14 Fan Orifice References -----	30



These instructions must be used in conjunction with the standard heater installation manual. These are generic conversion kits for each rating. Any extra components that come with the conversion kit need to be disposed of accordingly.



**After converting any Gen ZZ burner to propane it will then become Gen BB and burner label needs to be modified in permanent ink to indicate this.**



**If the unit is already manufactured for LP then the only change for altitude is the fan orifice plate. Refer to section 14, page 30, for the correct plate and part number.**

**Table 1 - Conversion kit references**

Natural Gas Model	Conversion Kit Part Number (VPS/VCS/VPT/VCT)	LP Gas Model/BTU per hour AFTER CONVERSION	Altitude Range
<b>60</b>	<b>1001412</b>	18/60,000	0-10,000ft
<b>80</b>	<b>1001413</b>	25/80,000	0-10,000ft
<b>100</b>	<b>1001414</b>	30/100,000	0-10,000ft
<b>125</b>	<b>1001415</b>	38/125,000	0-10,000ft
<b>150</b>	<b>1001416</b>	45/150,000	0-10,000ft
<b>170<sup>(a)</sup></b>	<b>1001417<sup>(a)</sup></b>	45/150,000	0-10,000ft
<b>170<sup>(b)</sup></b>	<b>1001418<sup>(b)</sup></b>	50/169,000	0-2,000ft
<b>200</b>	CONVERSION KIT NOT AVAILABLE		

*Notes:*









- (a) *This kit is only to be used on Gen. ZZ VPS170 and VCS170 units which will convert them to VPS150 and VCS150 Gen. BB burners.*
- (b) *This kit is only to be used on Gen. ZZ VPT170 and VCT170 and all Gen. BB VP/VC units 0 - 2000 ft ONLY.*







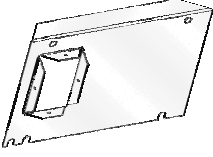

**Section 1: Propane Conversion Kit Parts List/Technical Data**

<b>KIT PART NUMBER</b>				<b>1001412</b>
<i>For use with models - VPS60, VCS60, VPT60 &amp; VCT60</i>				
<b>Part #</b>	<b>Qty</b>	<b>Description</b>	<b>Part Photo</b>	<b>Quality Criteria</b>
D303076	1	Propane Conversion Manual VC/VP		
270412	1	Grommet 12.5 x 9.5mm		
270459	1	M6 retaining washer		
270653	2	Propane Data Conversion Label for VPS60 / VCS60		Gas Mainifold Pressure: singular box
270654	2	Propane Data Conversion Label for VPT60 / VCT60		Gas Mainifold Pressures: twin boxes
270374	1	Gas Valve Propane Conversion Kit		
269948	1	Burner orifice plate		Stamped as indicated
270366	2	3.0mm EPDM Sponge Gasket to suit Burner Casting (with adhesive)		
269957	1	Flame Plate Type 1		Large hole in centre, smooth outer edge.
270398	1	Std. multi hole gas orifice 1.1mm		Stamped '1.1'
270328	1	Baffle Plate For Vision Burners		
270414	2	No. 8 x 1/2" S/Steel Self Tapper		
269924	1	Blown fan orifice plate to suit three fixing plate, 9 x 10mm sq.		9 holes, Stamped as indicated
269925	1	Blown fan orifice plate to suit three fixing plate, 10 x 10mm sq.		10 holes, Stamped as indicated

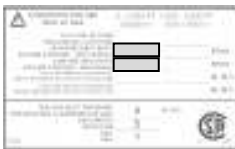
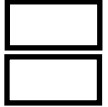
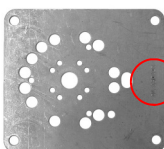
*continued*

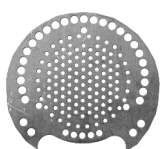
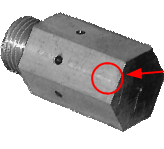
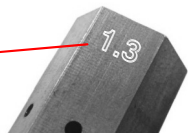
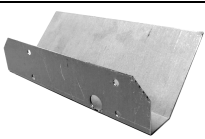

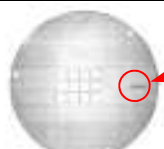



**1001412**



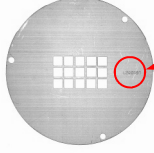



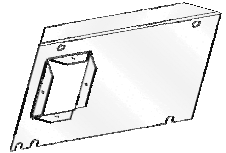

Part #	Qty	Description	Part Photo	Quality Criteria
269928	1	Blown fan orifice plate to suit three fixing plate, 12 x 10mm sq.		 12 holes, Stamped as indicated
269929	1	Blown fan orifice plate to suit three fixing plate, 14 x 10mm sq.		 14 holes, Stamped as indicated
270450	4	No. 6 x 3/8" BZP Self Tapper		 Only required for generation ZZ VPS60 ONLY!
270365	1	Closure Plate Gasket		 Only required for generation ZZ VPS60 ONLY!
269911	1	Fan Flange Plate		 Only required for generation ZZ VPS60 ONLY!

KIT PART NUMBER				1001413
For use with models - VPS80, VCS80, VPT80 & VCT80				
Part #	Qty	Description	Part Photo	Quality Criteria
D303076	1	Propane Conversion Manual VC/VP		
270412	1	Grommet 12.5 x 9.5mm		
270459	1	M6 retaining washer		
270655	2	Propane Data Conversion Label for VPS80 / VCS80		Gas Mainfold Pressures: singular box 
270656	2	Propane Data Conversion Label for VPT80 / VCT80		Gas Mainfold Pressures: twin boxes 
270374	1	Gas Valve Propane Conversion Kit		
269949	1	Burner orifice plate		 Stamped as indicated
270366	2	3.0mm EPDM Sponge Gasket to suit Burner Casting (with adhesive)		
269958	1	Flame Plate Type 2		Solid centre, smooth outer edge.
270399	1	Std. multi hole gas orifice 1.3mm		 Stamped '1.3'
270328	1	Baffle Plate For Vision Burners		
270414	2	No. 8 x 1/2" S/Steel Self Tapper		
269925	1	Blown fan orifice plate to suit three fixing plate, 10 x 10mm sq.		 10 holes, Stamped as indicated
269928	1	Blown fan orifice plate to suit three fixing plate, 12 x 10mm sq.		 12 holes, Stamped as indicated

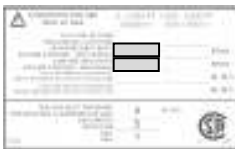
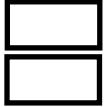
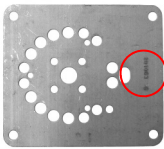
continued

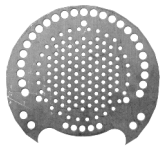
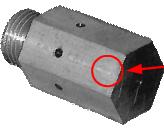
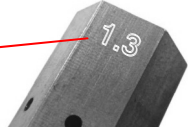
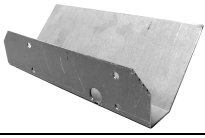







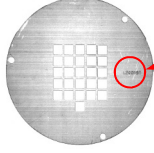

1001413

Part #	Qty	Description	Part Photo	Quality Criteria
269929	1	Blown fan orifice plate to suit three fixing plate, 14 x 10mm sq.		14 holes, Stamped as indicated
269930	1	Blown fan orifice plate to suit three fixing plate, 15 x 10mm sq.		15 holes, Stamped as indicated
1011095	1	Blown fan orifice plate to suit three fixing plate, 16 x 10mm sq.		16 holes, Stamped as indicated
270450	4	No. 6 x 3/8" BZP Self Tapper		 Only required for generation ZZ VPS80 ONLY!
270365	1	Closure Plate Gasket		 Only required for generation ZZ VPS80 ONLY!
269911	1	Fan Flange Plate		 Only required for generation ZZ VPS80 ONLY!





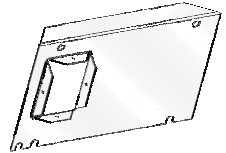



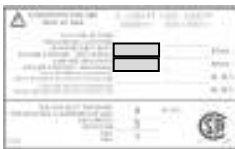
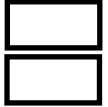
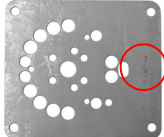

KIT PART NUMBER				1001414
For use with models - VPS100, VCS100, VPT100 & VCT100				
Part #	Qty	Description	Part Photo	Quality Criteria
D303076	1	Propane Conversion Manual VC/VP		
270412	1	Grommet 12.5 x 9.5mm		
270459	1	M6 retaining washer		
270657	2	Propane Data Conversion Label for VPS100 / VCS100		Gas Mainifold Pressures: singular box 
270658	2	Propane Data Conversion Label for VPT100 / VCT100		Gas Mainifold Pressures: twin boxes 
270374	1	Gas Valve Propane Conversion Kit		
269980	1	Burner orifice plate		 Stamped as indicated
270366	2	3.0mm EPDM Sponge Gasket to suit Burner Casting (with adhesive)		
269958	1	Flame Plate Type 2		Solid centre, smooth outer edge.
270399	1	Std. multi hole gas orifice 1.3mm		 Stamped '1.3'
270328	1	Baffle Plate For Vision Burners		
270414	2	No. 8 x 1/2" S/Steel Self Tapper		
269929	1	Blown fan orifice plate to suit three fixing plate, 14 x 10mm sq.		 14 holes, Stamped as indicated
1011095	1	Blown fan orifice plate to suit three fixing plate, 16 x 10mm sq.		 16 holes, Stamped as indicated

continued

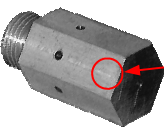
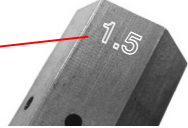
1001414



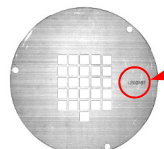





Part #	Qty	Description	Part Photo	Quality Criteria
269932	1	Blown fan orifice plate to suit three fixing plate, 21 x 10mm sq.		 21 holes, Stamped as indicated
269933	1	Blown fan orifice plate to suit three fixing plate, 26 x 10mm sq.		 26 holes, Stamped as indicated
269934	1	Blown fan orifice plate to suit three fixing plate, 37 x 10mm sq.		 37 holes, Stamped as indicated
270450	4	No. 6 x 3/8" BZP Self Tapper		 Only required for generation ZZ VPS100 ONLY!
270365	1	Closure Plate Gasket		 Only required for generation ZZ VPS100 ONLY!
269911	1	Fan Flange Plate		 Only required for generation ZZ VPS100 ONLY!



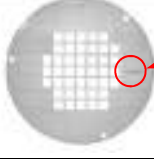



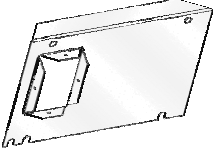

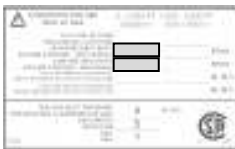

KIT PART NUMBER				1001415
For use with models - VPS125, VCS125, VPT125 & VCT125				
Part #	Qty	Description	Part Photo	Quality Criteria
D303076	1	Propane Conversion Manual VC/VP		
270412	1	Grommet 12.5 x 9.5mm		
270459	1	M6 retaining washer		
270659	2	Propane Data Conversion Label for VPS125 / VCS125		Gas Mainifold Pressures: singular box 
270660	2	Propane Data Conversion Label for VPT125 / VCT125		Gas Mainifold Pressures: twin boxes 
270374	1	Gas Valve Propane Conversion Kit		
269951	1	Burner orifice plate		 Stamped as indicated
270366	2	3.0mm EPDM Sponge Gasket to suit Burner Casting (with adhesive)		
269959	1	Flame Plate Type 3		Large hole in centre, toothed outer edge, 2 holes center top tooth.
270400	1	Std. multi hole gas orifice 1.5mm		 Stamped '1.5'
269931	1	Blown fan orifice plate to suit three fixing plate, 18 x 10mm sq.		 18 holes, Stamped as indicated
269932	1	Blown fan orifice plate to suit three fixing plate, 21 x 10mm sq.		 21 holes, Stamped as indicated
269933	1	Blown fan orifice plate to suit three fixing plate, 26 x 10mm sq.		 26 holes, Stamped as indicated

continued

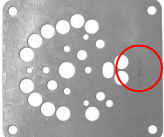

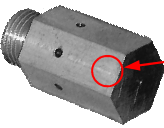

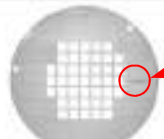
1001415

Part #	Qty	Description	Part Photo	Quality Criteria
269934	1	Blown fan orifice plate to suit three fixing plate, 37x 10mm sq.		 37 holes, Stamped as indicated
1011096	1	Blown fan orifice plate to suit three fixing plate, 42 x 10mm sq.		 42 holes, Stamped as indicated
270450	4	No. 6 x 3/8" BZP Self Tapper		 Only required for generation ZZ VPS125 ONLY!
270365	1	Closure Plate Gasket		 Only required for generation ZZ VPS125 ONLY!
269911	1	Fan Flange Plate		 Only required for generation ZZ VPS125 ONLY!

KIT PART NUMBER				1001416
For use with models - VPS150, VCS150, VPT150 & VCT150				
Part #	Qty	Description	Part Photo	Quality Criteria
D303076	1	Propane Conversion Manual VC/VP		
270412	1	Grommet 12.5 x 9.5mm		
270459	1	M6 retaining washer		
270661	2	Propane Data Conversion Label for VPS150 / VCS150		Gas Mainifold Pressures: singular box 
270662	2	Propane Data Conversion Label for VPT150 / VCT150		Gas Mainifold Pressures: twin boxes 
270374	1	Gas Valve Propane Conversion Kit		
269952	1	Burner orifice plate		Stamped as indicated
270366	2	3.0mm EPDM Sponge Gasket to suit Burner Casting (with adhesive)		
269959	1	Flame Plate Type 3		Large hole in centre, toothed outer edge, 2 holes center top tooth.
270401	1	Std. multi hole gas orifice 1.7mm		Stamped '1.7'
269933	1	Blown fan orifice plate to suit three fixing plate, 26 x 10mm sq.		26 holes, Stamped as indicated
269934	1	Blown fan orifice plate to suit three fixing plate, 37 x 10mm sq.		37 holes, Stamped as indicated
1011096	1	Blown fan orifice plate to suit three fixing plate, 42 x 10mm sq.		42 holes, Stamped as indicated



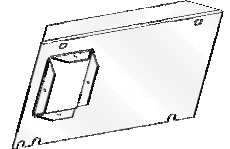







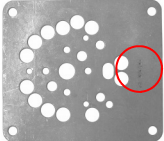

*continued*

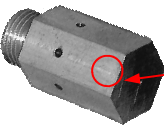
**1001416**

<b>Part #</b>	<b>Qty</b>	<b>Description</b>	<b>Part Photo</b>	<b>Quality Criteria</b>
270450	4	No. 6 x 3/8" BZP Self Tapper		 <i>Only required for generation ZZ VPS150 ONLY!</i>
270365	1	Closure Plate Gasket		 <i>Only required for generation ZZ VPS150 ONLY!</i>
269911	1	Fan Flange Plate		 <i>Only required for generation ZZ VPS150 ONLY!</i>



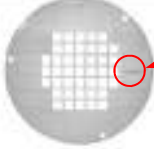



**KIT PART NUMBER**  
**For use with models VPS170 & VCS170**  
**with Generation Code ZZ. 0-10,000ft**

**1001417**

Part #	Qty	Description	Part Photo	Quality Criteria
D303076	1	Propane Conversion Manual VC/VP		
270412	1	Grommet 12.5 x 9.5mm		
270459	1	M6 retaining washer		
270661	2	Propane Data Conversion Label for VPS150 / VCS150		Gas Mainifold Pressures: singular box 
270374	1	Gas Valve Propane Conversion Kit		
269952	1	Burner orifice plate		 Stamped as indicated
270366	2	3.0mm EPDM Sponge Gasket to suit Burner Casting (with adhesive)		
269959	1	Flame Plate Type 3		Large hole in centre, toothed outer edge, 2 holes center top tooth.
270401	1	Std. multi hole gas orifice 1.7mm		 Stamped '1.7'
269933	1	Blown fan orifice plate to suit three fixing plate, 26 x 10mm sq.		 26 holes, Stamped as indicated
269934	1	Blown fan orifice plate to suit three fixing plate, 37 x 10mm sq.		 37 holes, Stamped as indicated
1011096	1	Blown fan orifice plate to suit three fixing plate, 42 x 10mm sq.		 42 holes, Stamped as indicated

continued

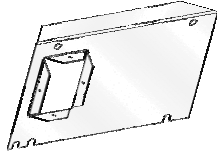
1001417









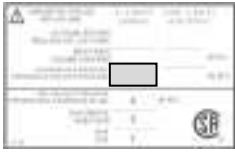

Part #	Qty	Description	Part Photo	Quality Criteria
270375	1	1/2" NPT Standard Jet Carrier		 Cut groove Indicates NPT Thread
270450	4	No. 6 x 3/8" BZP Self Tapper		 Only required for generation ZZ VPS150 ONLY!
270365	1	Closure Plate Gasket		 Only required for generation ZZ VPS150 ONLY!
269911	1	Fan Flange Plate		 Only required for generation ZZ VPS150 ONLY!

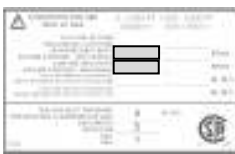
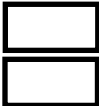
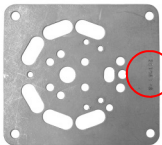
 This kit will de-rate burner to 150,000kBtu

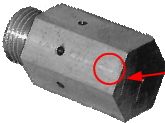
**KIT PART NUMBER**

**1001418**

**For use with models VPS170, VCS170, VPT170 & VCT170 with Generation Code BB and VPT170 & VCT 170 with Generation Code ZZ. 0-2000ft ONLY**

Part #	Qty	Description	Part Photo	Quality Criteria
D303076	1	Propane Conversion Manual VC/VP		
270412	1	Grommet 12.5 x 9.5mm		
270459	1	M6 retaining washer		
270663	2	Propane Data Conversion Label for VPS170 / VCS170		Gas Mainifold Pressures: singular box 
270664	2	Propane Data Conversion Label for VPT170 / VCT170		Gas Mainifold Pressures: twin boxes 
270374	1	Gas Valve Propane Conversion Kit		
269953	1	Burner orifice plate		 Stamped as indicated
270366	2	3.0mm EPDM Sponge Gasket to suit Burner Casting (with adhesive)		
269960	1	Flame Plate Type 4		Large hole in centre, toothed outer edge, plain centre top tooth.
270403	1	Std. multi hole gas orifice 1.9mm		 Stamped '1.9'
269937	1	Blown fan orifice plate to suit four fixing plate, 15 x 10mm sq.		 15 holes, Stamped as indicated
270375	1	1/2" NPT Standard Jet Carrier		 Cut groove Indicates NPT Thread

## Section 2

### Step by step conversion instructional data

Table 2 - VPS Conversion		VPS MODEL NUMBERS						
		60	80	100	125	150	170*	170
Conversion Kit Required		1001412	1001413	1001414	1001415	1001416	1001417*	1001418
Step	Operation							
1	Burner Orifice Replacement	SECTION 3						
2	Fit Turbulators	SECTION 4						
3	Fit Flame Plate	SECTION 5						
4	Replace Gas Orifice	SECTION 6a					SECTION 6b	
5	Install Baffle Plate	SECTION 7			NOT REQUIRED			
6	Refit Burner Head	SECTION 8						
7	Convert Gas Valve	SECTION 9a						
9	Replace Fan Orifice	SECTION 10a					SECTION 10a	SECTION 10b
10	Replace Data Badge	SECTION 11						
11	Re-commissioning	SECTIONS 12 - 14						

**i** If the unit is already manufactured for LP then the only change for altitude is the fan orifice plate. Refer to section 14, page 30, for the correct plate and part number.

\* VPS170 generation code ZZ ONLY

**i** Please note: The LPG gas pressure must be reset according to the values in Section 13.

Part Code	Description
B	Gas Valve
H	Gas Orifice
J	Jet Carrier
K2	Fan Orifice Plate
K3	Fan Flange Plate
K4	Fan Support Bracket
M	Gaskets
M2	Fan Plate Gasket
P	Burner Orifice Plate
Q	Flame Plate Location **
R	Baffle Plate Location **
**not shown	

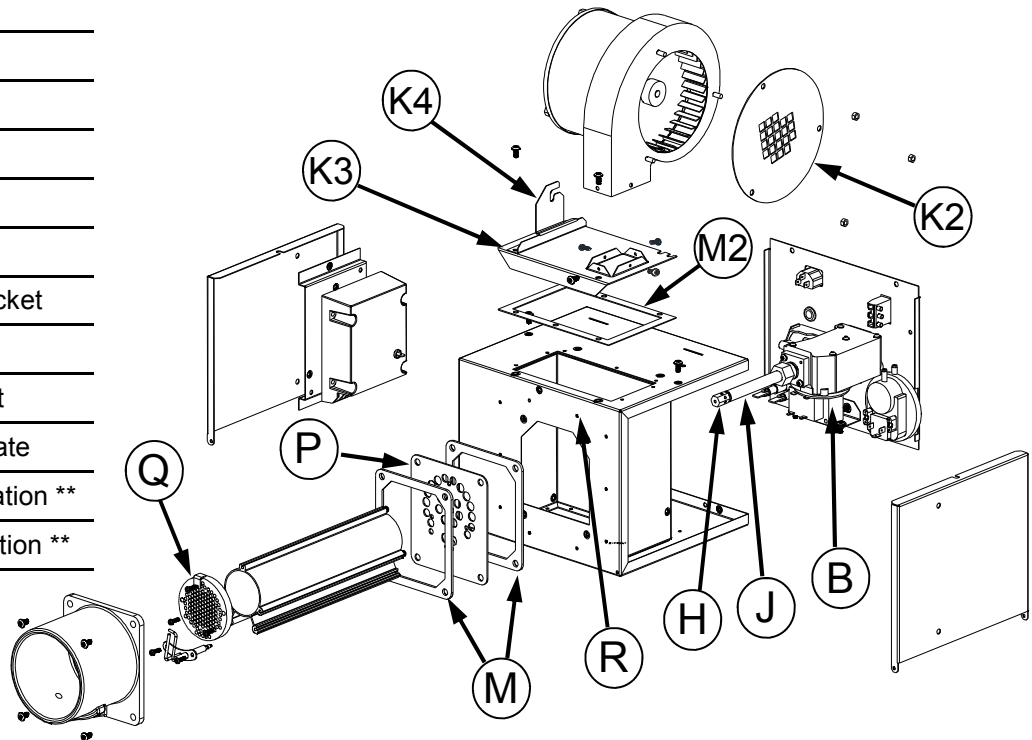

**VPS model  
Exploded view**



Table 3 - VPT, VCS, VCT Conversion		VPT, VCS, VCT MODEL NUMBERS						
		60	80	100	125	150	170*	170
Conversion Kit Required (VCS)		1001412	1001413	1001414	1001415	1001416	1001417*	1001418
(VPT & VCT)		1001412	1001413	1001414	1001415	1001416	N/A	1001418
Step	Operation							
1	Burner Orifice Replacement	SECTION 3						
2	Fit Turbulators	SECTION 4						
3	Fit Flame Plate	SECTION 5						
4	Replace Gas Orifice	SECTION 6a				SECTION 6c		
5	Install Baffle Plate	SECTION 7			NOT REQUIRED			
6	Refit Burner Head	SECTION 8						
7	Convert Gas Valve	SECTION 9b						
9	Replace Fan Orifice	SECTION 10c				SECTION 10c	SECTION 10d	
10	Replace Data Badge	SECTION 11						
11	Re-commissioning	SECTIONS 12 - 14						

**i** If the unit is already manufactured for LP then the only change for altitude is the fan orifice plate. Refer to section 14, page 30, for the correct plate and part number.

\* VCS170 generation code ZZ ONLY

**i** Please note: The LPG gas pressure must be reset according to the values in Section 13.

Part Code	Description
B	Gas Valve
H	Gas Orifice
J	Jet Carrier
K2	Fan Orifice Plate
M	Gaskets
P	Burner Orifice Plate
Q	Flame Plate Location **
R	Baffle Plate Location **
**not shown	

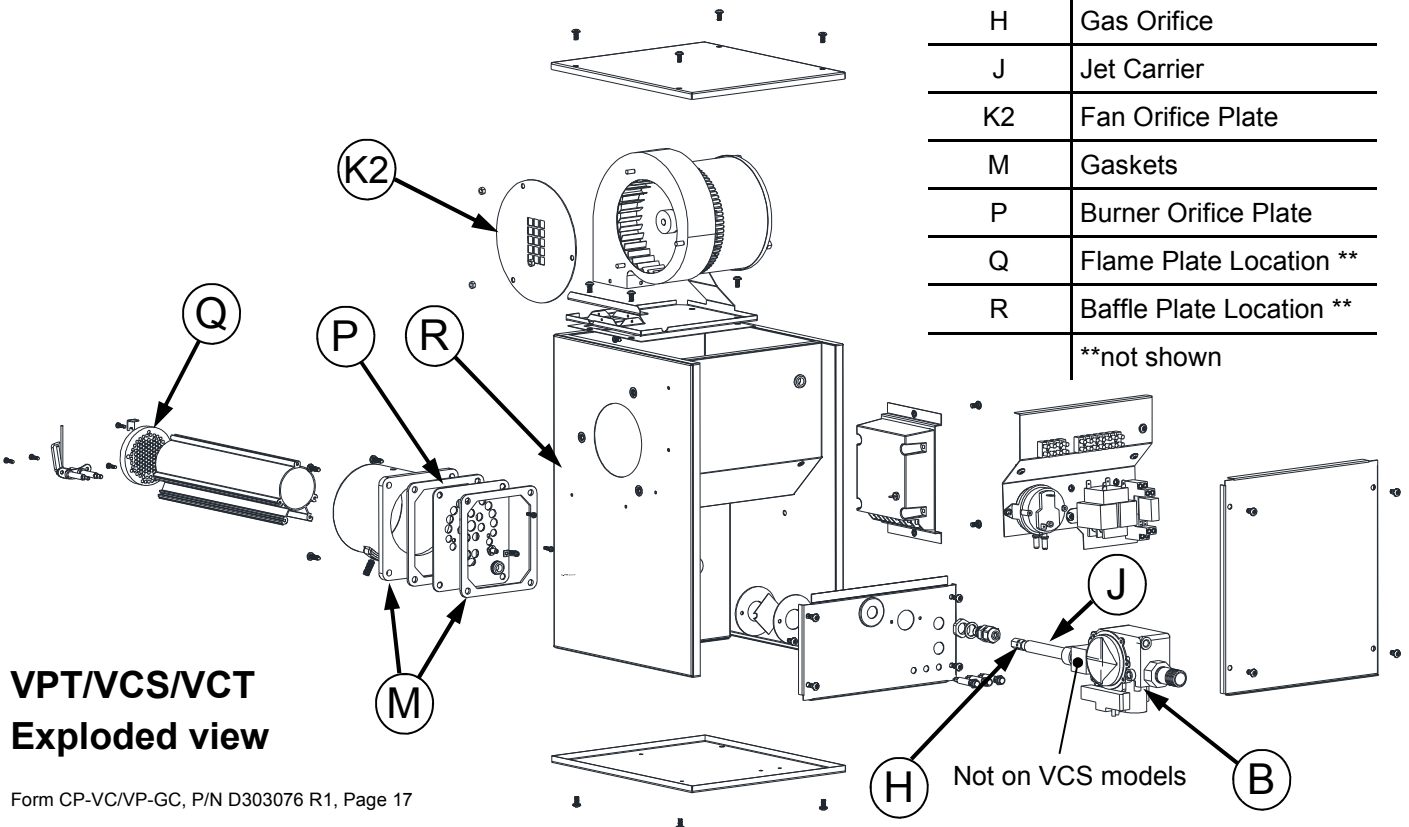

### Section 3

#### Burner Orifice Plate Replacement (where req'd).

Step 1: Remove the four retaining screws securing the burner casting using a number 2 crosshead screwdriver.



Step 2: Remove the supporting casting and gasket.



Step 3: The burner head assembly can now be disconnected by separating the connectors of the ignition and flame probe lead assemblies and removing the ground lead and pressure switch silicon tube.



Step 4: The burner orifice plate can then be released by removing the 3 fixing screws from the burner tube using a number 2 crosshead screwdriver.

Step 5: Using a flathead screwdriver remove the retaining washer securing the impulse stud (arrowed). Remove the stud. Remove the cable grommet from the old orifice plate and attach to the replacement plate.

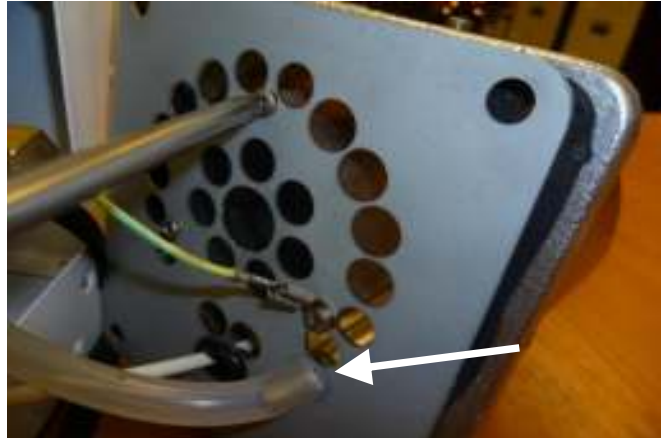

Step 6: Fit new propane burner orifice plate to burner tube ensuring the impulse stud is facing the correct direction. The cable grommet is fitted to the obround hole at the bottom of the plate (arrowed).

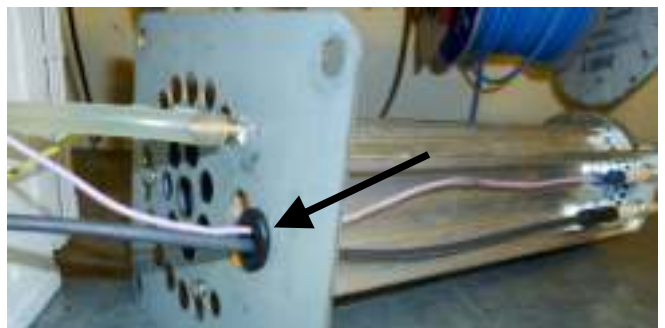

Two new gaskets are provided and should be used when reconnecting to the burner housing. Dispose of the old gaskets.



See Section 1 for correct burner orifice plate identification.

### Section 4

#### Turbulator Information.

These heaters may have a different arrangement of turbulators and tube inserts when converted for use at high altitude. This section will guide you through the process of changing these components where necessary.

## Section 4a Tube inserts

Prior to conversion a number of the natural gas heaters use a tube insert part # 1005500 or part # 270489 See Figure 1.

**WARNING: THIS TUBE INSET IS NOT REQUIRED WHEN OPERATING ON LPG, PLEASE CHECK INSIDE THE FIRING LEG. IF FITTED, REMOVE AND DISCARD!**

Length 5' (1524mm) Part # 270489 (models 60/80/100)  
Length 3' (914mm) Part # 1005500 (model 125)



Figure 1

The burner insert (where required) is inserted into the first emitter tube from where it is joined to the second emitter tube. See Figure 2.



Figure 2

## Section 4b Turbulators

When converting Natural Gas to LPG, fit the additional turbulators as indicated below. See Figure 3.

Model 100 S30 - **ADD ONE** off Part # 116019  
Model 170 S50 - **ADD TWO** off Part # 116019  
Model 150 U40 - **REMOVE FOUR** off Part # 116019  
(5000ft-10,000ft altitude only)

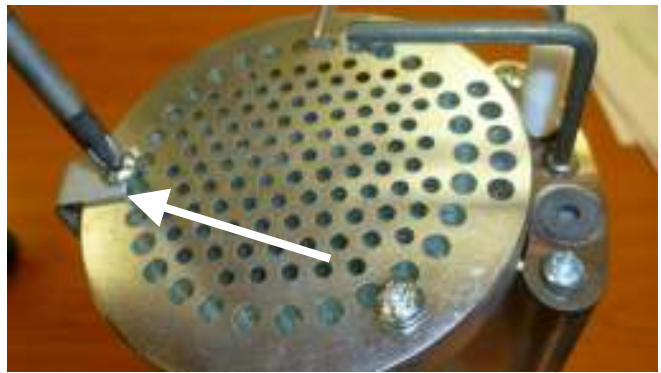

Figure 3

## Section 5 Flame Plate Attachment (all models).

Step 1: Remove the 3 screws holding the burner head in place with a number 2 crosshead screwdriver.

Step 2: Discard the spacer bracket arrowed in next photo.



Step 3: Align the 5 holes in the flame plate (arrowed) with the 5 holes on the outer edge of the burner head as shown.

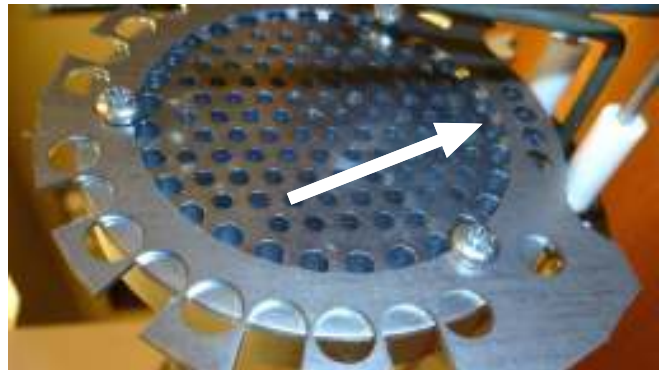

Step 4: Attach flame plate to the burner tube using the 3 screws removed in step 1. Ensure the flame plate is mounted **ON TOP** of the original burner head.

### Flame Plate Identification



**TYPE 1**  
Part # 269957

**TYPE 2**  
Part # 269958



**TYPE 3**  
Part # 269959

**TYPE 4**  
Part # 269960



## Section 6a

### Gas Orifice Replacement (60kBTU to 150kBTU models only).

Step 1: Remove the burner casting as detailed in section 3.

Step 2: Using a 12mm wrench remove the gas orifice from the jet carrier by rotating counter-clockwise.



Step 3: Replace the gas orifice with the propane alternative ensuring an approved gas sealant is used on the thread. **DO NOT OVERTIGHTEN.**

 See Section 1 for gas orifice ID.

## Section 6b

### Gas Orifice Replacement (VPS 170kBTU models only).

Step 1: Remove the burner casting as detailed in section 3

Step 2: Remove the two securing screws from the base of the jet carrier, noting the ground terminal connection.



Step 3: Remove the four screws holding the rear burner plate in position (arrowed in next photo). Remove the rear plate.



Step 4: The jet carrier/gas orifice can now be detached from the gas valve. The two screws retaining the gas valve can then be removed.

Step 5: Replace the manifold/gas orifice with the propane alternative ensuring an approved gas sealant is used on the thread.

**DO NOT OVERTIGHTEN.**

 See Section 1 for gas orifice ID.

## Section 6c

### Gas Orifice Replacement (VPT, VCS/T) 170kBTU models only).

Step 1: Remove the burner casting as detailed in section 3.

Step 2: Remove the two securing screws from the base of the jet carrier, noting ground terminal connection.



Step 3: Remove the four screws securing the base plate and remove.

Step 4: Remove the gas valve wiring connections, noting their positions.

Step 5: Remove the four screws (arrowed) securing the gas valve inlet plate to the burner housing and remove plate. Remove gas valve rearwards.

Step 6: The jet carrier/gas orifice can now be detached from the gas valve.



Step 7: Replace the jet carrier/gas orifice with the propane alternative ensuring an approved gas sealant is used on the thread.

**DO NOT OVERTIGHTEN.**



See Section 1 for gas injector identification.

## Section 7

### Baffle Plate Installation (60kBTU to 100kBTU models only).

Step 1: Locate the baffle plate in the LP conversion kit.

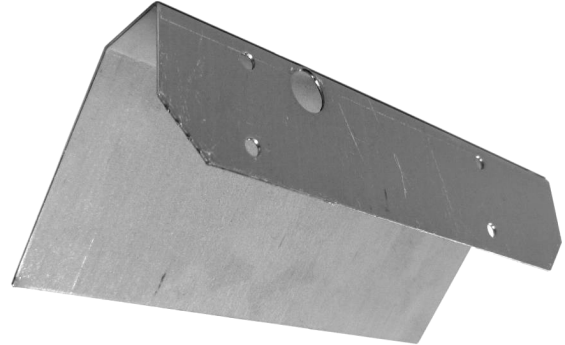

Step 2: Carefully insert the baffle plate at an angle through the combustion chamber opening, making sure that the holes are positioned towards the holes at the front of the burner box.

For VC burners there will already be 2 screws located in these holes. Remove these screws before proceeding.

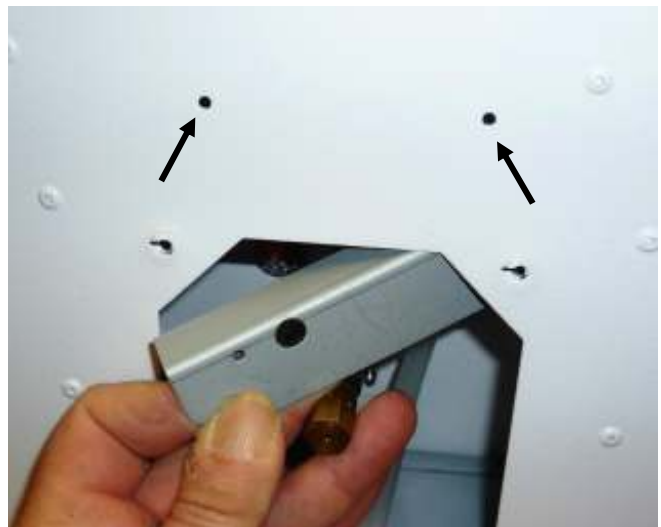

Step 3: Align the holes and screw the baffle plate to the burner box using the self tapping screws supplied.



## Section 8 Refitting Burner Head (all models).

Step 1: Reconnect the ignition and flame probe leads, the ground lead and pressure switch silicon tube.

Take care to pass the leads and silicone tube through the gasket.

New gaskets are provided. The old gaskets should be disposed of accordingly.

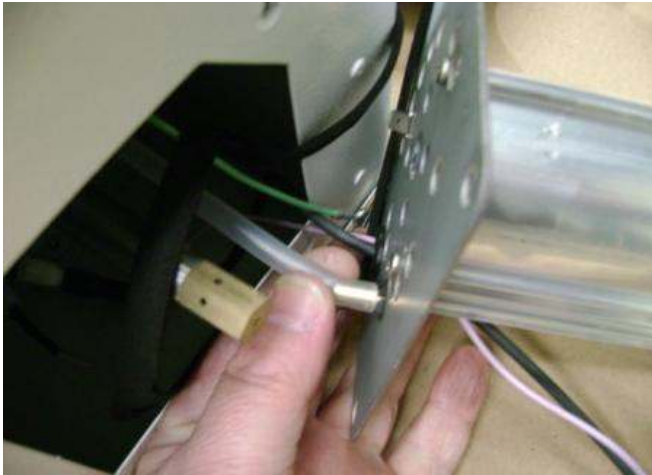

Step 2: Locate the burner head assembly over the gas orifice ensuring the leads do not get pinched between the orifice plate and burner housing.

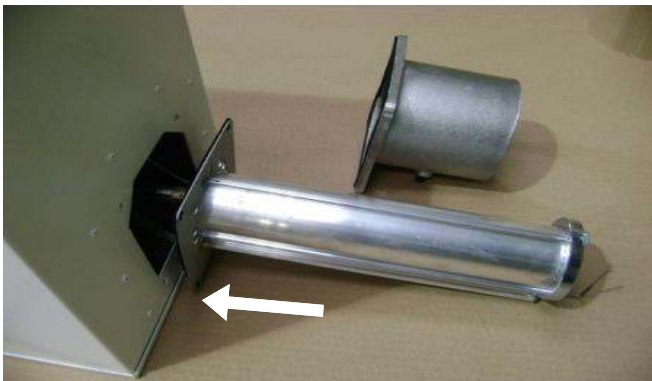

Step 3: Refit the gasket and casting over the burner head tube and fix with the original screws.



## Section 9a Gas Valve LP Conversion (VPS).

Step 1: To gain access to the gas valve loosen screw in burner lid and open the right hand burner access door.

Step 2: Remove the gas valve regulator cover screw (brass).

Step 3: Remove the adjustment screw (white) beneath cover screw.

Step 4: Remove natural gas regulator spring (color-coded silver/plain) from regulator sleeve.

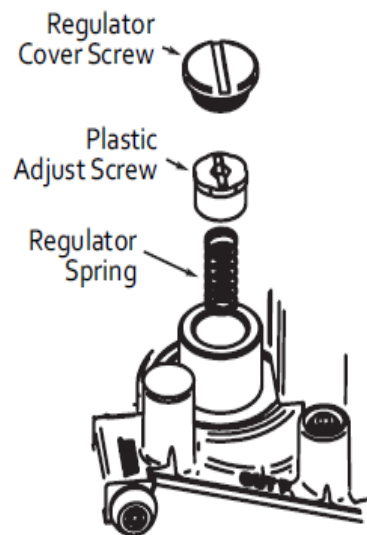

Single Stage Valve

Step 5: Insert the LP regulator spring (provided in the conversion kit and color-coded white) into the regulator sleeve.

Step 6: Replace the regulator adjustment screw and adjust approximately 8 turns clockwise from the beginning of the thread.

Step 7: Adjust gas pressure as detailed in Section 13a.

Step 8: Replace regulator cover screw.

Step 9: Attach warning label to outside of burner housing where it can be readily seen.

Step 10: Fit small round LP label to the top of the converted gas valve cover screw.

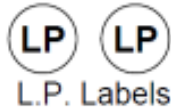

L.P. Labels

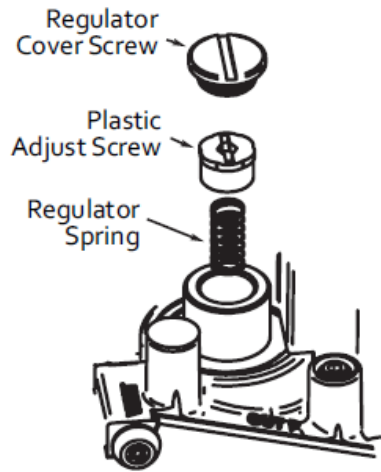

Single Stage Valve

### Section 9b

#### Gas Valve LP Conversion (VPT, VCS/T).

**i** VPT / VCT burners have a two-stage gas valve.  
VCS burners have a single stage gas valve.

Step 1: To gain access to the gas valve, remove the 4 screws securing the bottom access panel with a number 2 crosshead screwdriver. Remove panel.



Step 2: Remove the gas valve regulator cover screw(s) (brass).

Step 3: Remove the adjustment screw(s) (white) beneath cover screw/screws.

Step 4: Remove the natural gas regulator spring(s) (color-coded silver/plain) from regulator sleeve(s).

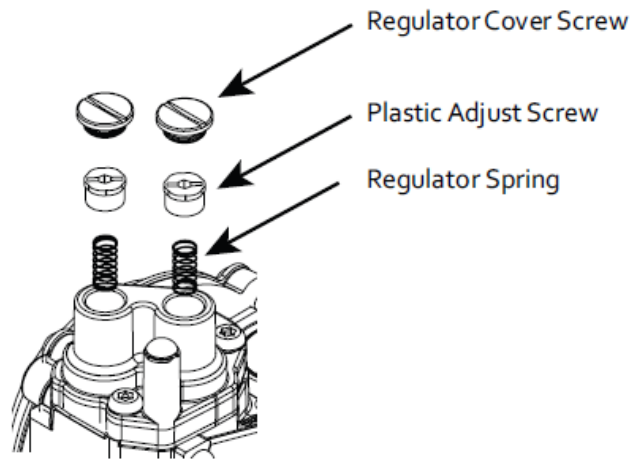

Two-Stage Valve

Step 5: Insert the LP regulator spring(s) (provided in the conversion kit and color-coded white) into the regulator sleeve(s).

Step 6: Replace the regulator adjustment screw(s) and adjust approximately 8 turns clockwise from the beginning of the thread.

Step 7: Adjust gas pressure as detailed in Section 13a or 13b.

Step 8: Replace regulator cover screw.

Step 9: Attach warning label to outside of burner housing where it can be readily seen. (see next page)

Step 10: Fit small round LP label to the top of the converted gas valve cover screw. (see next page)



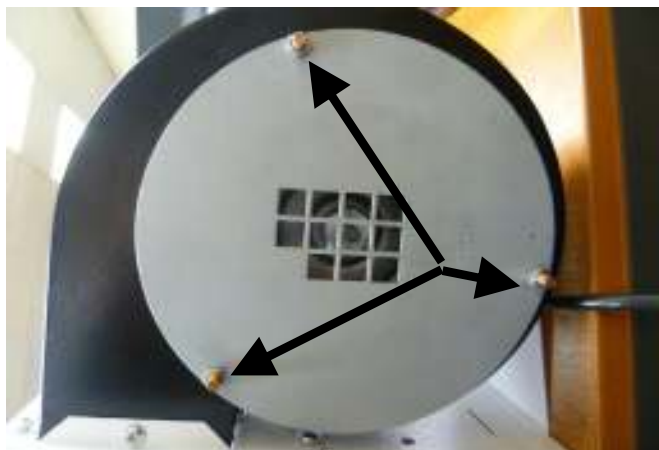

### Section 10a Fan Orifice Plate Replacement (3 screws VPS).

Step 1: Remove the 3 off 8mm nuts (arrowed) securing the fan orifice plate with an 8mm wrench. Slide orifice plate off the 3 protruding studs.



Step 2: Fit the replacement fan orifice plate. Re-attach the 3 x 8mm nuts (arrowed) turning clockwise, using the wrench to secure to the combustion fan.

-  Take care not to cross thread the fasteners.
-  See sections 14a-14f for correct fan orifice plate identification.

**For VPS burners Generation code ZZ ONLY**  
(refer to section 2 for component identification)

Step 3: Remove the four fan outlet retaining screws and unplug from burner box.

Step 4: Remove the two screws holding the fan support bracket (K3) / fan flange plate (K4) to the

burner housing and remove the fan and bracket assy.

Step 5: Remove the remaining two screws and remove the fan flange plate.

Step 6: Locate the self adhesive gasket (M2) and position on the underside of the new fan flange plate.

Step 7: Position the new fan flange plate onto the burner housing and re-fit screws from step 5.

Step 8: Re-position fan/fan support bracket on top of fan flange plate ensuring the fan outlet is placed OUTSIDE the flange. Replace the remaining two screws removed from step 4.



Step 9: Fix fan outlet to housing using 4 x No.6 screws in kit.

### Section 10b Fan Orifice Plate Replacement (4 screws VPS).

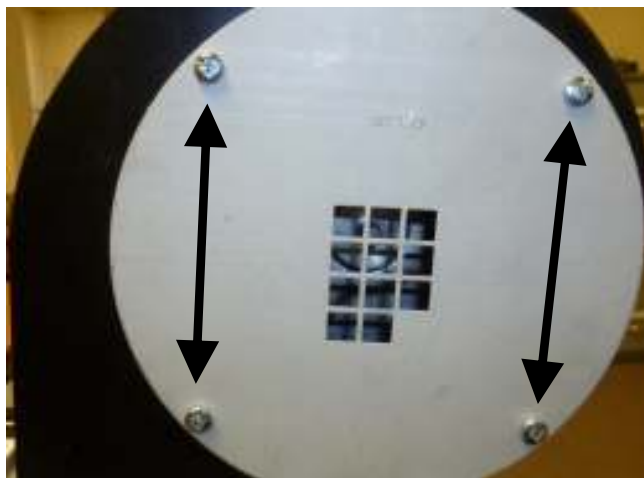
Step 1: Using a number 2 crosshead screwdriver remove the four screws (arrowed) securing the fan orifice plate. Remove plate.



Step 2: Fit the replacement fan orifice plate and secure with the same four screws.

-  Take care not to cross thread the screws.
-  See section 14a-14f for correct fan orifice plate identification.

### Section 10c Fan Orifice Plate Replacement (3 screws VPT, VCS/VCT).

Step 1: Remove the top cover of the burner using a number 2 crosshead screwdriver to expose the combustion fan.





Step 2: Remove the four screws (arrowed), three of which can not be seen in the photograph. Lift out the fan assembly to access the fan.



Step 3: Follow the procedure in Section 10a to change the fan orifice plate.

**i** For correct fan orifice plate identification, see sections 14a-14f for VCS and sections 14g-14m for VPT/VCT

Step 4: Refit the fan and cover.

### Section 10d Fan Orifice Plate Replacement (4 screws VPT, VCS/VCT).

Step 1: Remove fan following procedure in Section 10c.

Step 2: Follow procedure in Section 10b to change the fan orifice plate.

**i** For correct fan orifice plate identification, see sections 14a-14f for VCS and sections 14g-14m for VPT/VCT

Step 4: Refit the fan and cover.

### Section 11 Data Badge Replacement (all models).

**i** Ensure the single stage LP conversion label is used on VPS/VCS burners and the two-stage LP conversion label is used when converting VPT/VCT burners.

Step 1: Locate the High Altitude/LP conversion data label.

Step 2: With a permanent marker pen Indicate the following:

- Altitude of the appliance installation.
- Heat input of the unit.
- Gas manifold pressure.

Refer to section 13a and 13b for VPS/VCS and section 13c and 13d for VPT/VCT to obtain correct data.

<b>CONVERTED FOR USE WITH LP GAS</b>		
ALTITUDE SETTING RÉGLAGE DE L'ALTITUDE		
INPUT RATE VOLUME D'ENTRÉE		BTU/h
GAS MANIFOLD PRESSURE PRESSION DU COLLECTEUR DE GAZ		IN. W.C.
MIN. GAS INLET PRESSURE PRESSION MIN. D'ADMISSION DE GAZ	11	IN. W.C.
GAS ORIFICE INJECTEUR	7 x 1.5	
GAS GAZ	LP	
Pl. No. 270659		

Step 3: Affix new label over the technical data section of the natural gas data label as shown below.

<b>INFRARED RADIANT TUBE HEATER RADIATEUR À TUVE RAYONNANT À INFRAROUGE</b>		GENERATION <input type="checkbox"/>
MODEL No. MODÈLE NO.	ANSI Z39.26-2011 CSA 2.340-2011	SERIAL No. No. DE SÉRIE
<b>CONVERTED FOR USE WITH LP GAS</b>		
ALTITUDE SETTING RÉGLAGE DE L'ALTITUDE	4500FT	
INPUT RATE VOLUME D'ENTRÉE	112,50	BTU/h
GAS MANIFOLD PRESSURE PRESSION DU COLLECTEUR DE GAZ	7.6	IN. W.C.
MIN. GAS INLET PRESSURE PRESSION MIN. D'ADMISSION DE GAZ	11	IN. W.C.
GAS ORIFICE INJECTEUR	7 x 1.5	
GAS GAZ	LP	
Pl. No. 270659		
CLEARANCE FROM COMBUSTIBLE CONSTRUCTION DÉGAGEMENT DE LA STRUCTURE COMBUSTIBLE		
		MASTER CONTRACT: ÉLECTRICAL/ÉLECTRICIEN 120V / 60Hz 1 EA. Modèle 25-1224

**Section 12**  
**Re-commissioning (all models).**

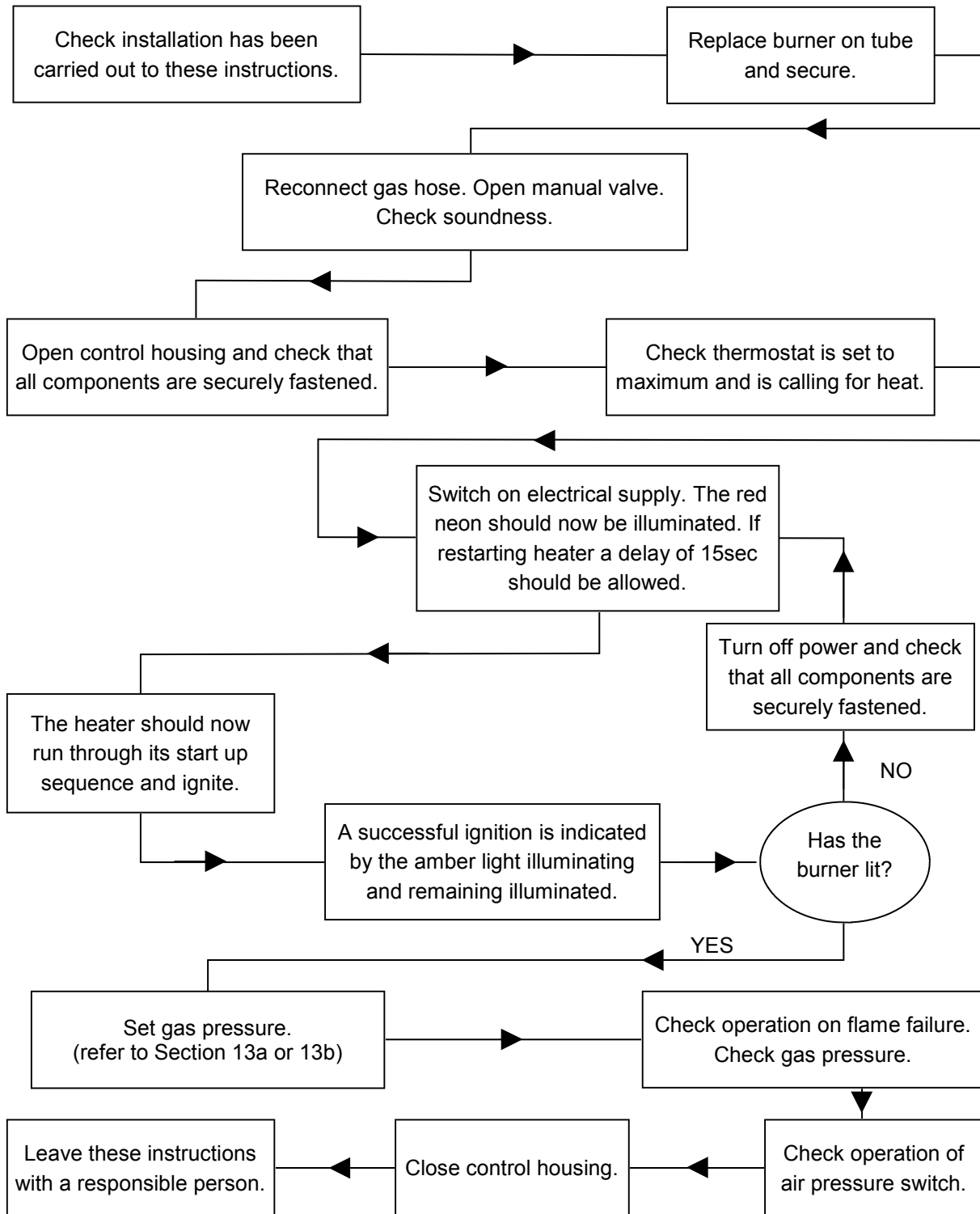

 Once gas outlet pressure has been set, replace gas valve regulator cover screw(s) and attach round LP label/ labels to the top of the regulator cover screw(s).

### Section 13a - Orifice Pressure Adjustment by Altitude (VPS/VCS) USA

Altitude		LP Gas ("wc)						
Feet	Meters	60	80	100	125	150	170*	170
0-2000	0-610	5.5	5.2	8.0	7.6	7.0	7.0	6.1
2001-3000	611-915	5.5	5.2	8.0	7.6	7.0	7.0	N/A
3001-4000	916-1220	5.5	5.2	8.0	7.6	7.0	7.0	N/A
4001-5000	1221-1524	5.5	5.2	8.0	7.6	7.0	7.0	N/A
5001-6000	1525-1829	5.5	5.2	8.0	7.6	6.4	6.4	N/A
6001-7000	1830-2134	5.5	5.2	8.0	7.6	6.4	6.4	N/A
7001-8000	2135-2439	5.5	5.2	8.0	7.6	6.4	6.4	N/A
8001-9000	2440-2743	5.5	5.2	8.0	7.6	6.4	6.4	N/A
9001-10000	2744-3048	5.5	5.2	8.0	7.6	6.4	6.4	N/A

### Orifice Pressure Adjustment by Altitude (VPS/VCS) Canada

Altitude		LP Gas ("wc)						
Feet	Meters	60	80	100	125	150	170*	170
0-2000	0-610	5.5	5.2	8.0	7.6	7.0	7.0	6.1
2001-4500	611-1372	5.4	5.0	7.8	7.4	6.8	6.8	N/A

### Section 13b - Btu/h Heat Input by Altitude (VPS/VCS) USA

Altitude		LP Gas Normal Input Btu/h						
Feet	Meters	60	80	100	125	150	170*	170
0-2000	0-610	60,000	80,000	100,000	125,000	150,000	150,000	169,000
2001-3000	611-915	56,400	75,200	94,000	117,500	141,000	141,000	N/A
3001-4000	916-1220	55,200	73,600	92,000	115,000	138,000	138,000	N/A
4001-5000	1221-1524	54,000	72,000	90,000	112,500	135,000	135,000	N/A
5001-6000	1525-1829	52,800	70,400	88,000	110,000	132,000	132,000	N/A
6001-7000	1830-2134	51,600	68,800	86,000	107,500	129,000	129,000	N/A
7001-8000	2135-2439	50,400	67,200	84,000	105,000	126,000	126,000	N/A
8001-9000	2440-2743	49,200	65,600	82,000	102,500	123,000	123,000	N/A
9001-10000	2744-3048	48,000	64,000	80,000	100,000	120,000	120,000	N/A

### Btu/h Heat Input by Altitude (VPS/VCS) Canada

Altitude		LP Gas Normal Input Btu/h						
Feet	Meters	60	80	100	125	150	170*	170
0-2000	0-610	60,000	80,000	100,000	125,000	150,000	150,000	169,000
2001-4500	611-1372	54,000	72,000	90,000	112,500	135,000	135,000	N/A

\*Generation ZZ model 170 de-rated from 169kBTU to 150kBTU



Note: Burners will naturally de-rate at high altitude.

### Section 13c - Orifice Pressure Adjustment by Altitude (VPT/VCT) USA

Altitude		Burner Setting	LP Gas ("wc)					
Feet	Meters		60	80	100	125	150	170
0-2000	0-610	Hi Lo	5.5 3.5	5.2 2.9	8.0 4.4	7.6 4.6	7.0 3.3	6.1 3.6
2001-3000	611-915	Hi Lo	5.5 3.5	5.2 2.9	8.0 4.4	7.6 4.6	7.0 3.3	N/A
3001-4000	916-1220	Hi Lo	5.5 3.5	5.2 2.9	8.0 4.4	7.6 4.6	7.0 3.3	N/A
4001-5000	1221-1524	Hi Lo	5.5 3.5	5.2 2.9	8.0 4.4	7.6 4.6	7.0 3.3	N/A
5001-6000	1525-1829	Hi Lo	5.5 3.5	5.2 2.9	8.0 4.4	7.6 4.6	6.4 3.3	N/A
6001-7000	1830-2134	Hi Lo	5.5 3.5	5.2 2.9	8.0 4.4	7.6 4.6	6.4 3.3	N/A
7001-8000	2135-2439	Hi Lo	5.5 3.5	5.2 2.9	8.0 4.4	7.6 4.6	6.4 3.3	N/A
8001-9000	2440-2743	Hi Lo	5.5 3.5	5.2 2.9	8.0 4.4	7.6 4.6	6.4 3.3	N/A
9001-10000	2744-3048	Hi Lo	5.5 3.5	5.2 2.9	8.0 4.4	7.6 4.6	6.4 3.3	N/A

### Orifice Pressure Adjustment by Altitude (VPT/VCT) Canada

Altitude		Burner Setting	LP Gas ("wc)					
Feet	Meters		60	80	100	125	150	170
0-2000	0-610	Hi Lo	5.5 3.5	5.2 2.9	8.0 4.4	7.6 4.6	7.0 3.3	6.1 3.6
2001-4500	611-1372	Hi Lo	5.4 3.4	5.0 2.8	7.8 4.2	7.4 4.4	6.8 3.1	N/A



Note: Burners will naturally de-rate at high altitude.

### Section 13d - Btu/h Heat Input by Altitude (VPT/VCT) USA

Altitude		Burner Setting	LP Gas ("wc)					
Feet	Meters		60	80	100	125	150	170
0-2000	0-610	Hi	60,000	80,000	100,000	125,000	150,000	169,000
		Lo	48,000	60,000	75,000	95,000	100,000	125,000
2001-3000	611-915	Hi	56,400	75,200	94,000	117,500	141,000	N/A
		Lo	45,120	56,400	70,500	89,300	94,000	
3001-4000	916-1220	Hi	55,200	73,600	92,000	115,000	138,000	N/A
		Lo	44,160	55,200	69,000	87,400	92,000	
4001-5000	1221-1524	Hi	54,000	72,000	90,000	112,500	135,000	N/A
		Lo	43,200	54,000	67,500	85,500	90,000	
5001-6000	1525-1829	Hi	52,800	70,400	88,000	110,000	132,000	N/A
		Lo	42,240	52,800	66,000	83,600	88,000	
6001-7000	1830-2134	Hi	51,600	68,800	86,000	107,500	129,000	N/A
		Lo	41,280	51,600	64,500	81,700	86,000	
7001-8000	2135-2439	Hi	50,400	67,200	84,000	105,000	126,000	N/A
		Lo	40,320	50,400	63,000	79,800	84,000	
8001-9000	2440-2743	Hi	49,200	65,600	82,000	102,500	123,000	N/A
		Lo	39,360	49,200	61,500	77,900	82,000	
9001-10000	2744-3048	Hi	48,000	64,000	80,000	100,000	120,000	N/A
		Lo	38,400	48,000	60,000	76,000	80,000	

### Btu/h Heat Input by Altitude (VPT/VCT) Canada

Altitude		Burner Setting	LP Gas ("wc)					
Feet	Meters		60	80	100	125	150	170
0-2000	0-610	Hi	60,000	80,000	100,000	125,000	150,000	169,000
		Lo	48,000	60,000	75,000	95,000	100,000	125,000
2001-4500	611-1372	Hi	54,000	72,000	90,000	112,500	135,000	N/A
		Lo	43,200	54,000	67,500	85,500	90,000	



Note: Burners will naturally de-rate at high altitude.

**Section 14a - VPS/VCS LP Gas Fan Orifice 0-2000ft (0-610m) USA**

Model	Configuration	Fan Orifice Part #	Quantity 10mm Holes
60	S20-40, U20-40	269924	9
80	S30-40, U20-40	269925	10
100	S30-50, U40	269929	14
125	S30-60, U40-60	269931	18
150	S40-70, U40-60	269933	26
170*	S50-80, U60-80	269933	26
170	S50-80, U60-80	269937	15

**Section 14b - VPS/VCS LP Gas Fan Orifice 2001-5000ft (611-1524m) USA**

Model	Configuration	Fan Orifice Part #	Quantity 10mm Holes
60	S20, U20	269925	10
	S30-40, U40	269924	9
80	S30, U20	269928	12
	S40, U40	269925	10
100	S30	1011096	16
	S40-50, U40	269929	14
125	S30-40	269932	21
	S50-60, U40-60	269931	18
150	S40, U40	269934	37
	S50-70, U60	269933	26
170*	S40, U40	269934	37
	S50-70, U60	269933	26
170	N/A	N/A	N/A



**Important note: If heaters have been fitted with a 5ft Tube Pack then the orifice required must be fitted from the closest size downwards.**

e.g. S35 should be treated as if it were a S30, S55 should be treated as if it were a S50 etc..

**Section 14c - VPS/VCS LP Gas Fan Orifice 5001-8000ft (1525-2439m) USA**

Model	Configuration	Fan Orifice Part #	Quantity 10mm Holes
60	S20, U20	269928	12
	S30-40, U40	269925	10
80	S30, U20	269930	15
	S40, U40	269928	12
100	S30	269933	26
	S40-50, U40	269932	21
125	S30-40	269934	37
	S50-60, U40-60	269933	26
150**	U40***	1011096	42
	S50-70, U60	1011096	42
170*	U40***	1011096	42
	S50-70, U60	1011096	42
170	N/A	N/A	N/A

**Section 14d - VPS/VCS LP Gas Fan Orifice 8001-10000ft (2440-3048m) USA**

Model	Configuration	Fan Orifice Part #	Quantity 10mm Holes
60	S20, U20	269929	14
	S30-40, U40	269928	12
80	S30, U20	1011095	16
	S40, U40	269929	14
100	S30	269934	37
	S40-50, U40	269933	26
125	S30-40	1011096	42
	S50-60, U40-60	269934	37
150**	U40***	1011096	42
	S50-70, U60	1011096	42
170*	U40***	1011096	42
	S50-70, U60	1011096	42
170	N/A	N/A	N/A



**\*\* Note: model 150 S40 is not allowed. \* Note: model 170\* S40 is not allowed.**

**\*\*\* Note: Remove ALL turbulator strips**

**Section 14e - VPS/VCS LP Gas Fan Orifice 0-2000ft (0-610m) Canada**

<b>Model</b>	<b>Configuration</b>	<b>Fan Orifice Part #</b>	<b>Quantity 10mm Holes</b>
<b>60</b>	S20-40, U20-40	269924	9
<b>80</b>	S30-40, U20-40	269925	10
<b>100</b>	S30-50, U40	269929	14
<b>125</b>	S30-60, U40-60	269931	18
<b>150</b>	S40-70, U40-60	269933	26
<b>170*</b>	S50-80, U60-80	269933	26
<b>170</b>	S50-80, U60-80	269937	15

**Section 14f - VPS/VCS LP Gas Fan Orifice 2001-4500ft (611-1372m) Canada**

<b>Model</b>	<b>Configuration</b>	<b>Fan Orifice Part #</b>	<b>Quantity 10mm Holes</b>
<b>60</b>	S20, U20	269925	10
	S30-40, U40	269924	9
<b>80</b>	S30, U20	269928	12
	S40, U40	269925	10
<b>100</b>	S30	1011096	16
	S40-50, U40	269929	14
<b>125</b>	S30-40	269932	21
	S50-60, U40-60	269931	18
<b>150</b>	S40, U40	269934	37
	S50-70, U60	269933	26
<b>170*</b>	S40, U40	269934	37
	S50-70, U60	269933	26
<b>170</b>	N/A	N/A	N/A



**Section 14g - VPT/VCT LP Gas Fan Orifice 0-2000ft (0-610m) USA**

Model	Configuration	Fan Orifice Part #	Quantity 10mm Holes
60	S20-40, U20-40	269924	9
80	S30-40, U40	269925	10
100	S30-40, U40	269929	14
125	S30-50, U40	269931	18
150	S40-60, U40-60	269933	26
170	S50-70, U60	269937	15

**Section 14h - VPT/VCT LP Gas Fan Orifice 2001-5000ft (611-1524m) USA**

Model	Configuration	Fan Orifice Part #	Quantity 10mm Holes
60	S20, U20	269925	10
	S30-40, U40	269924	9
80	S30	269928	12
	S40, U40	269925	10
100	S30	1011096	16
	S40, U40	269929	14
125	S30-40	269932	21
	S50, U40	269931	18
150	S40, U40	269934	37
	S50-60, U60	269933	26
170	N/A	N/A	N/A



**Important note: If heaters have been fitted with a 5ft Tube Pack then the orifice required must be fitted from the closest size downwards.**

e.g. S35 should be treated as if it were a S30, S55 should be treated as if it were a S50 etc..

**Section 14j - VPT/VCT LP Gas Fan Orifice 5001-8000ft (1525-2439m) USA**

Model	Configuration	Fan Orifice Part #	Quantity 10mm Holes
<b>60</b>	S20, U20	269928	12
	S30-40, U40	269925	10
<b>80</b>	S30	269930	15
	S40, U40	269928	12
<b>100</b>	S30	269933	26
	S40, U40	269932	21
<b>125</b>	S30-40	269934	37
	S50, U40	269933	26
<b>150**</b>	U40***	1011096	42
	S50-60, U60	1011096	42
<b>170</b>	N/A	N/A	N/A

**Section 14k - VPT/VCT LP Gas Fan Orifice 8001-10000ft (2440-3048m) USA**

Model	Configuration	Fan Orifice Part #	Quantity 10mm Holes
<b>60</b>	S20, U20	269929	14
	S30-40, U40	269928	12
<b>80</b>	S30	1011095	16
	S40, U40	269929	14
<b>100</b>	S30	269934	37
	S40, U40	269933	26
<b>125</b>	S30-40	1011096	42
	S50, U40	269934	37
<b>150**</b>	U40***	1011096	42
	S50-60, U60	1011096	42
<b>170</b>	N/A	N/A	N/A



**\*\* Note: model 150 S40 is not allowed.**

**\*\*\* Note: Remove ALL turbulator strips**

**Section 14I - VPT/VCT LP Gas Fan Orifice 0-2000ft (0-610m) Canada**

<b>Model</b>	<b>Configuration</b>	<b>Fan Orifice Part #</b>	<b>Quantity 10mm Holes</b>
<b>60</b>	S20-40, U20-40	269924	9
<b>80</b>	S30-40, U40	269925	10
<b>100</b>	S30-40, U40	269929	14
<b>125</b>	S30-50, U40	269931	18
<b>150</b>	S40-60, U40-60	269933	26
<b>170</b>	S50-70, U60	269937	15

**Section 14m- VPT/VCT LP Gas Fan Orifice 2001-4500ft (611-1372m) Canada**

<b>Model</b>	<b>Configuration</b>	<b>Fan Orifice Part #</b>	<b>Quantity 10mm Holes</b>
<b>60</b>	S20, U20	269925	10
	S30-40, U40	269924	9
<b>80</b>	S30	269928	12
	S40, U40	269925	10
<b>100</b>	S30	1011096	16
	S40, U40	269929	14
<b>125</b>	S30-40	269932	21
	S50, U40	269931	18
<b>150</b>	S40, U40	269934	37
	S50-60, U60	269933	26
<b>170</b>	N/A	N/A	N/A

Specifications & illustrations subject to change without notice or incurring obligations.  
© Nortek Global HVAC, LLC 2016, All rights reserved.  
All trade marks are the property of their respective organizations.  
Printed in U.S.A. (08-16).  
Form CP-VC/VC-GC (08-16), D303076 R1