

"Apollo"[®]

PRODUCT CATALOG

BALL VALVES 

BUTTERFLY VALVES 

ACTUATION 

SAFETY RELIEF VALVES 

HYDRONIC & STEAM HEATING 

MIXING VALVES 

WATER PRESSURE REDUCING VALVES 

GATE, GLOBE & CHECK VALVES 

BACKFLOW PREVENTION 

STRAINERS 

LIQUID LEVEL GAUGES 

PLUMBING SPECIALTIES 

COMMERCIAL PRODUCTS

CPCA9000

PRODUCT CATALOG

CONTENTS



3-4
SERIES NO. & MODEL NO.



6
LEAD FREE PRODUCTS



SECTION A
NEW PRODUCTS



SECTION B
BALL VALVES



SECTION C
BUTTERFLY VALVES



SECTION D
ACTUATION



SECTION E
SAFETY RELIEF VALVES



SECTION F
HYDRONIC & STEAM HEATING



SECTION G
MIXING VALVES



SECTION H
WATER PRESSURE
REDUCING VALVES



SECTION I
BACKFLOW PREVENTION



SECTION J
GATE, GLOBE & CHECK VALVES



SECTION K
STRAINERS



SECTION L
LIQUID LEVEL GAUGES



SECTION M
PLUMBING SPECIALTIES



LEADFREE
CERTIFIED



LEADFREE
OPTIONS

THROUGHOUT THIS CATALOG, PRODUCTS THAT ARE CERTIFIED **LEAD FREE*** OR HAVE A **LEAD FREE*** OPTION WILL BE IDENTIFIED WITH THESE LOGOS.

*LEAD FREE: The wetted surfaces of this product shall contain no more than 0.25% lead by weighted average. Complies with Federal Public Law 111-380. ANSI 3rd party approved and listed.

Conbraco Industries offers a wide range of Apollo® products for potable and non-potable applications. When the use of lead free valves is required by code, specification or legislation, it is the sole responsibility of our customers to ensure that only lead free Apollo® products are installed in systems intended for potable water service. Further information related to our product offering and the U.S. Safe Drinking Water Act (SDWA) is available at www.apollovalves.com/lead_free or by contacting Conbraco Customer Service.

** Imported products may be identified as "Apollo International™" or "Conbraco International™".

TABLE OF CONTENTS BY SERIES NO.

PART NUMBER	MODEL NUMBER	PAGE	PART NUMBER	MODEL NUMBER	PAGE	PART NUMBER	MODEL NUMBER	PAGE
4A-100/4ALF-100	DC4A	I-3	30	103T	J-3	70LF-300/400		B-8
4ALF-100 (LBF)	DC4A	I-10	30	106T/107T	J-4	70-600		B-9
4A-200/4ALF	RP4A	I-5	30	111T/116T	J-4	70-800/70LF-800		B-9
4ALF-200(LBF)	RP4A	I-16	31-200/400/	BD90/BDT	M-7	70-900		B-10
4A-400	DCAP	I-21	31-600/700	BD	M-8	70B		B-7
4A-500	PVB-4A	I-8	32-100		B-10	70-HC/70LF-HC		B-7
4ALF-600	DCDA-4A	I-4, I-13	33/33LF	120S/120T/121T	J-7	71-100		B-13
4ALF-700(LBF)	RPDA-4A	I-7, I-18	33	122T/127T/128T	J-8	71-500		B-13
4AnLF-100(LBF)	DC-4An	I-12	34ALF	MVA	G-4 - G-5	73A-100		B-14
4AnLF-200	RP-4An	I-17	34BLF	MVB	G-6 - G-7	75-100-41		B-15
4AnLF-600(LBF)	DCDA-4An	I-15	34C/34CLF	MVC	G-8 - G-9	76F-100-A		B-14
4AnLF-700(LBF)	RPDA-4An	I-19	34DLF	MVD	G-10	77F/77FLF		B-30
4C-100	CBBP	I-27	34ELF	MVE	G-14 - G-15	77-100		B-15
4FP3	DUC-4FP	I-23	34HL	MVHL	G-12 - G-13	77-200		B-16
4ALF-300	DUC-4A	I-22	34-200	TV	G-11	77-900		B-16
4SGLF/4SG/4S	DC-4SG	I-11	35	FF	F-5	77C-100/200-A		B-3
4SGLF-600	DCDA-4SG	I-14	35-200	HB	M-7	77CLF-100/200-A		B-4
4A-900/4ALF	SVB-4A	I-9	35-300	BDQ	M-8	77C-100/200-27A		F-10
6GA	610F, 620F	J-5	35-603	FFB	F-5	77CLF-300-A		B-8
6GA	611F, 621F	J-6	36LF	PR	H-5 - H-7	77C-ULA		B-3
6GB	711F, 721F	J-9	36CLF	PRC	H-8 - H-9	77D		B-17
6PLF	IBV-125	B-24	36ELF/36ELF-G	PRE	H-10 - H-15	77G-UL		B-26
6SC	910F	J-12	36HLF	PRH	H-16 - H-18	77V		B-35
6SC	910FLW	J-12	37-200	VR	F-4	77VLF		B-36
6SC	920F	J-13	38-100/38LF-100	AVB1	I-20	77W/77WLF		B-34
6WC	910WB, 910	J-14	38-200	AVB2	I-20	77W-HC/77WLF-HC		B-35
7K-100		B-17	38LF-300	HBV2	I-24	78-124/125		B-29
7K-SV		B-18	38-304	HBDUC	I-25	78-130		B-19
9A-100		B-21	38LF-400	HBVAF2	I-24	78-256		B-29
10	RVW10	E-7 - E-9	38-502	LFDUC	I-25	78-260/290		B-18
10-322/10-512	RV32, RVS52	E-5 - E6	40-000/40LF-000	FPV	I-28	78-620		B-19
10-600	RVW60/61	E-7 - E-9	40-200-T2S	RP-40S	I-14	78-660/962		B-20
12-200	RVS12	E-10	40-300/40LF-300	DUC	I-25	78-RV/78RV-P	EXV	F-12
13	RVS13	E-11	4ALF-400	DCAP	I-26	79-700		B-20
14-200	RVS14	E-12 - E-13	40-XT	EXP	F-23	80-100		B-25
14-400/500	RVA14	E-14 - E-17	41		M-3 - M-4	82-100/82LF-100		B-21
14-600	RVV14	E-15, E-17	44-100		M-6	82-200/82LF-200		B-21
15-100	RVA15	E-18 - E-19	50	GCB	M-7	82-200/240 MedGas		B-22-23
16-200/16LF-200	RVW16	E-20	50GB	GB50/GB50A	B-28	90-100-A		B-25
16-500/16LF-500	RVW16A	E-21	51	GC	M-8	94A		B-31
16XT	EXT	F-23	51G	GB10/15/16	B-27	94ALF-A		B-32
17-400	RVW17	E-22	52	GC2	M-8	94 MBV		B-24
18C-400/18C	TP/TPX	E-23	55	GCR	M-6	94VLF-A		B-37
18C-500	TPC	E-24	58	BAV	F-6	94XLF		B-37
19		E-25 - E29	58A		F-6	95ALF		B-33
20-100/20LF-100		L-6 - L-12	59/59LF	YB	K-2 - K-3	119		E-35 - E-39
20-200		L-6 - L-12	59-300/59LF-300	YBS	K-4	500		E-41 - E-46
20-300		L-6 - L-12	59V	YVB	K-4	612	YSS	K-4
20-410		L-6 - L-12	61-100/61LF-100	CVB	J-22	612	YCS/YCSW	K-5
20-600/800		L-6 - L-12	61-200/61LF-200	CVB	J-22	A127		H-19 - H-20
20-700/710		L-6 - L-12	61-500/61LF-500	CVBE	J-24	AD/AS	AD/AS	D-2
21		L-6 - L-12	61-600/61LF-500	CVBES	J-24	AE	AE	D-3
215	HPBFV	C-16	61-700	CV	J-26	AGD		I-19
230	HPBFV	C-16	61Y/61YLF	161S	J-10	Ball Valve Options		B-2, B-11 - B-12
23-400/23-600		L-6 - L-12	61Y/61YLF	161T	J-10	DPE		E-40
24-300		L-6 - L-12	61Y	162T	J-10	ENC4ANI		I-12
24-600		L-6 - L-12	61Y/61YLF	163S	J-10	I-2733/2734		M-1
25-600		L-6 - L-12	61Y/61YLF	163T	J-11	LC149		C-13 - C-14
260		C-16	61Y	164T	J-11	LD/WD 141		C-7 - C-12
26-100/26-300	CG/CGH	M-2	61Y	168T	J-11	LD/WD 145		C-7 - C-11
26-500	CGH	M-6	61Y	169T	J-11	W279900		H-20
27-200	RAV	F-23	62-100	CVS	J-23	W-8078-00	HCPG	H-20
27-400	SGS	M-3	62-500	CVSE	J-25	YCF	YCF	K-6
29		E-30 - E-34	70-100-BC		J-27	YCT	YCT	K-5
30/30LF	101S/101T	J-2	70-100/200		B-5			
30/30LF	102S	J-2	70LF-100/200		B-6			
30	102T-K	J-3	70-200		B-5			
30-30LF	102T	J-3	70-300/400		B-8			

New Product or Option

TABLE OF CONTENTS BY MODEL NO.

MODEL NUMBER	PART NUMBER	PAGE	MODEL NUMBER	PART NUMBER	PAGE	MODEL NUMBER	PART NUMBER	PAGE
AD/AS	AD/AS	D-2	GCB	50	M-7	TP	18C-400	E-23
AE	AE	D-3	GCR	55	M-6	TPC	18C-500	E-24
AVB1	38-100	I-23	HB	35-200	M-7	TPX	18C-402X	E-23
AVB1	38LF-100	I-23	HBDOC	38-304	I-25	TV	34-200	G-11
AVB2	38-200	I-23	HBV2	38LF-300	I-24	VR	37-200	F-4
BAV	58	F-6	HBVAF2	38LF-400	I-24	YB	59	K-2 - K-3
BD	31-600	M-8	HCPG	W-8078-00	H-20	YB	59LF	K-2 - K-3
BD	31-700	M-8	HPBFV	215	C-16	YBS	59-300/59LF-300	K-4
BDQ	35-300	M-8	HPBFV	230	C-16	YCF	YCF	K-6
BD90	31-200	M-7	HPBFV	260	C-16	YCS/YCSW	612	K-5
BD90	31-500	M-7	IBV125	6PLF	B-24	YCT	YCT	K-5
BDT	31-400	M-7	LFDUC	38-502	I-25	YSS	612	K-4
CBBP	4C-100	I-18	MVA	34ALF	G-4 - G-5	YVB	59V	K-4
CG	26-100	M-2	MVB	34B	G-6 - G-7	10IS	30/30LF	J-2
CGH	26-300	M-6	MVB	34BLF	G-6 - G-7	10IT	30/30LF	J-2
CGH	26-500	M-6	MVC	34C/34CLF	G-8 - G-9	102S	30/30LF	J-3
CV	61-700	J-26	MVD	34D	G-10	102T	30/30LF	J-3
CVB	61-100	J-22	MVD	34DLF	G-10	102T-K	30	J-3
CVB	61LF-100	J-22	MVE	34ELF	G-14 - G-15	103T	30	J-3
CVB	61-200	J-22	MVHL	34HL	G-12 - G-13	106T	30	J-4
CVB	61LF-200	J-22	PR	36LF	H-5 - H-7	107T	30	J-4
CVBE	61-500	J-24	PRC	36CLF	H-8 - H-9	111T	30	J-4
CVBE	61LF-500	J-24	PRE	36ELF	H-10 - H-15	116T	30	J-4
CVBES	61-600	J-24	PRH	36HLF	H-16 - H-18	120S	33/33LF	J-7
CVS	62-100	J-23	PVB-4A	4A-500	I-8	120T	33/33LF	J-7
CVSE	62-500	J-25	RAV	27-200	F-23	121T	33/33LF	J-7
DC-4An	4AnLF-100(LBF)	I-12	RP-40S	40-200-T2S	I-6	122T	33	J-8
DC-4SG	4SGLF/4SG/4S	I-11	RP-4An	4AnLF-200	I-17	127T	33	J-8
DC4A	4A-100	I-3	RP4A	4A-200	I-5	128T	33	J-8
DC4A	4ALF-100	I-3	RP4ALF	4ALF-200	I-5	16IS	61Y/61YLF	J-10
DC4A	4ALF-100(LBF)	I-10	RP4A	4ALF-200(LBF)	I-16	16IT	61Y/61YLF	J-10
DCAP	4A-400	I-21	RPDA-4A	4ALF-700	I-7, I-18	162T	61Y	J-10
DCDA-4A	4ALF-600(LBF)	I-13	RPDA-4An	4AnLF-700	I-19	163S	61Y/61YLF	J-10
DCDA-4An	4AnLF-600(LBF)	I-15	RV32/52	10-322/512	E-5 - E-6	163T	61Y/61YLF	J-11
DCDA-4SG	4SG-600	I-14	RVA14	14-400/500	E-14, E-17	164T	61Y	J-11
DPE	DPE	E-40	RVA15	15-100	E-18 - E-19	168T	61Y	J-11
DUCLF-4A	4ALF-300	I-22	RVS12	12-200	E-10	169T	61Y	J-11
DUC-4FP	4FP3	I-23	RVS13	13	E-11	610F	6GA	J-5
DUC-4A	4ALF-300	I-22	RVS14	14-200	E-12 - E-13	611F	6GA	J-6
EXP	40-XT	F-22	RVS32	10-322	E-4 - E-5	620F	6GA	J-5
EXT	16XT	F-22	RVS52	10-512	E-4 - E-5	621F	6GA	J-6
EXV	78RV/78LF-RV	F-12	RVV14	14-600	E-15, E-17	711F/721F	6GB	J-9
FF	35	F-5	RVW10	10	E-7 - E-9	910F	6SC	J-12
FFB	35-603	F-5	RVW16	16-200/16LF-200	E-20	910FLW	6SC	J-12
FPV	40-000/40LF-000	I-28	RVW16A	16-500/16LF-500	E-21	910WB	6WC	J-14
GB10/15	51G	B-27	RVW17	17-400	E-22	910WE	6WC	J-14
GB50/GB50A	50G	B-28	RVW60/61	10-600	M-3	920F	6SC	J-13
GC	51	M-8	SGS	27-400	M-2			
GC2	52	M-8	SVB	4A-900/4ALF-900	I-21			

New Product or Option

"Apollo" PIPING DESIGN SERVICES

ARE YOU FACING CHALLENGES
WITH YOUR PROJECTS?

**SOLUTIONS WITH APOLLO PIPING
DESIGN SERVICES INCLUDE:**
Coordination Drawings
Fabrication Drawings

3D CAD & BIM MODELS:
Download 3D CAD & BIM models including
.rvt | .dwg | .par | .sat | .jtm

Apollo Piping Design Services also offers
Material Take-offs, Cost Comparison,
Equipment Detail Packages and Thermal
Movement Design services.

CONTACT US, SO WE CAN HELP.



844.607.8521



designservice@conbraco.com



apollopingdesignservice.com

Download MasterSpec specification sections
apollovalves.com/masterspec

Find us in

M MASTERSPEC
building specs done right

Create your own custom specifications using SpecBuilderExpert
apollovalves.com/specbuilder

SpecBuilderExpert

A product of ARCOM



LEADFREE
OPTIONS

Certified by
Truesdail Laboratories

products include:

SERIES	SIZES	DESCRIPTION	CONNECTIONS
16LF	1/2" - 3/4"	Pressure Relief Valve	NPT
215/230+	2" - 24"	High Performance Butterfly Valve	Lug, Wafer
20LF-100	1/2"	Water Gauge	NPT
30LF	1/4" - 3"	Bronze Gate Valve	NPT, Solder, Press
33LF	1/4" - 2"	Bronze Globe Valve	NPT, Solder, Press
34ALF	1/2" - 1"	Mixing Valve	NPT, Solder, PEX, CPVC
34BLF	1/2" - 1"	Mixing Valve	NPT, Solder, PEX, CPVC
34CLF	3/4" - 2"	Mixing Valve	NPT
34DLF	3/8"	Mixing Valve	Compression
36LF	1/2" - 2"	Water Pressure Reducing Valve	NPT, Solder, PEX, CPVC
36CLF	1/2" - 1"	Water Pressure Reducing Valve	NPT, Solder, PEX, CPVC, Push, Press
36ELF	1/2" - 2"	Water Pressure Reducing Valve	NPT, Solder, PEX, CPVC, Push, Press
36HLF	1/2" - 3"	Water Pressure Reducing Valve	NPT, Flanged
38LF-100	1/4" - 2"	Atmospheric Vacuum Breaker	NPT
40LF-000	1/8"	Freeze Protection Valve	NPT
40LF-300	1/2" - 1"	Dual Check Valve	NPT, NPSM, BSPP
40LF-400	1/2" - 3/4"	Dual Check with Atmospheric Port	NPT, Solder, BSPP
40XT*	3/4"	Expansion Tanks, Potable	NPT
4ALF-100	1/2" - 2"	Double Check Valve	NPT
4ALF-100	2 1/2" - 12"	Double Check Valve	Flanged, Grooved
4ALF-200	1/2" - 2"	Reduced Pressure Assembly	NPT
4ALF-200	2-1/2" - 12"	Reduced Pressure Assembly	Flanged, Grooved
4ANLF-100	2-1/2" - 12"	Double Check Valve	Flanged, Grooved
4ANLF-200	2-1/2" - 12"	Reduced Pressure Assembly	Flanged, Grooved
4C100	1/4" - 3/8"	Carbonated Beverage Backflow Preventer	NPT, Flare
4FPLF300	1" - 1-1/4"	Residential Fire Protection Dual Check Valve	NPT, NPSM
4NLF300	3/8" - 1"	Dual Check Valve	NPT, NPSM, BSPP
4SG100	2-1/2" - 6"	Double Check Valve	Flanged, Grooved
59LF	1/8" - 4"	Strainer, Bronze	NPT, Push, Press
6GA	2" - 24"	Cast Iron Gate Valve	Flanged
6GB	2" - 10"	Cast Iron Globe Valve	Flanged
6PLF*	2" - 10"	Cast Iron Ball Valve	Flanged
6SC	2" - 20"	Cast Iron Globe Check Valve	Flanged
6WC	2" - 24"	Cast Iron Check Valve	Wafer
61LF100	1/4" - 3"	Check Valve, Bronze, Ball Cone	NPT, Push
61LF500	3/8" - 3/4"	Check Valve, Bronze, Soft Seat	NPT
61YLF	1/4" - 2"	Swing Check, Bronze	NPT, Solder, Press
70LF	1/4" - 4"	Ball Valve, Bronze	NPT, Solder
70LF-HC	1/2" - 1"	Ball Valve, Bronze, Hose Cap & Chain	NPT, Solder
76	1/4" - 3"	Ball Valve, SS Standard Port	NPT
76F	1/2" - 2"	Ball Valve, SS Full Port	NPT
77CLF-A	1/4" - 2-1/2"	Ball Valve, Bronze	NPT, Solder
77FLF	1/4" - 4"	Ball Valve, Brass	NPT, Solder
77VLF	1/2" - 4"	Ball Valve, Brass	Press
77WLF	1/2" - 2"	Ball Valve, Bronze	Press
77WLF-HC	1/2" - 3/4"	Ball Valve, Bronze, Hose Cap & Chain	Press
78LF-RV	3/4"	Ball Valve, Thermal Expansion Relief	NPT, Solder, PEX, Push
82LF	1/4" - 2-1/2"	Ball Valve, Bronze, 3 Piece	NPT, Solder / Brazed
86A	1/4" - 2"	Ball Valve, SS 3 Piece 1500 CWP	NPT, Socket Weld, Butt Weld
86B	1/4" - 2"	Ball Valve, SS 3 Piece Class 600	NPT, Socket Weld, Butt Weld
87A-200	1/2" - 4"	Ball Valve, SS ASME 150#	Flanged
94ALF-A*	1/4" - 4"	Ball Valve, Brass	NPT, Solder
94VLF-A*	1/2" - 4"	Ball Valve, Brass	Press
94XLF*	1/2" - 1"	Ball Valve, Lead Free Brass	PEX
95ALF*	1/2" - 1"	Ball Valve, Brass, Stop and Waste	NPT, Solder
LC149*	2" - 12"	Butterfly Valve	Lug
LD/WD 141*	2" - 24"	Butterfly Valve	Lug, Wafer
LD/WD 145	2" - 12"	Butterfly Valve	Lug, Wafer

*Apollo International

*List is not all inclusive; other lead free products available.
See individual product pages or submittals for lead free options.



"Apollo"® POWERPRESS *New!*



GAS

Sealing Element: HNBR
 Maximum Pressure: 230psi
 Temperature Range: -40° F to 194° F

NON-GAS

Sealing Element: EPDM
 Maximum Pressure: 230psi
 Temperature Range: -40° F to 302° F

The Apollo® POWERPRESS system offers a complete solution with a wide range of flexibility. The system can be utilized on standard steel pipe and can be used with different brands of press tools. Features including increased cup depths, mechanical Leak Before Press®, and visual inspection/identification help to promote clean and confident connections that minimize the potential for installation error by the end user.

DOUBLE ASSURANCE

All Apollo® POWERPRESS fittings and valves come equipped with a mechanical leak before press system that clearly indicates when a connection hasn't been pressed. They also feature a patented, color-coded, visual inspection ring that ultimately leads to far straighter and cleaner press connections when compared to the competition.

UNMATCHED QUALITY AND RELIABILITY

Apollo® POWERPRESS products are manufactured using fully automated modern machinery, ensuring a consistent, safe and high quality product. 100% of welded components undergo a leak test and all straight connectors with threaded ends are made from a single piece, thus eliminating potential leaks.

ADVANTAGES

- Full Line of Compact Fittings for Recessed Work (1/2" – 2")
- Visual Press Indicator
 - Clear Identification by Color
 - Tabs Break-Away When Properly Pressed
 - Straighter Runs from Significantly Reduced Pipe Deflection
- Mechanical Leak Before Press™
- Carbon Steel Press Ball Valve (**First in the Market**)
 - Factory Tested
 - No Need For Adapters
 - Shorter Laying Dimensions

APPROVED APPLICATIONS

- Chilled Water
- Hydronic Heating (50% glycol max)
- Low Pressure Steam (15 psi max)
- Compressed Air
- Fuel Gas: -40° F to 194° F (gas | HNBR seal only)



AMERICAN SOCIETY OF MECHANICAL ENGINEERS



AMERICAN SOCIETY OF SANITARY ENGINEERING



CSA INTERNATIONAL



CONFORMITÉ EUROPÉENNE/PRESSURE EQUIPMENT DIRECTIVE



INTERNATIONAL ASSOCIATION OF PLUMBING AND MECHANICAL OFFICIALS UNIFORM PLUMBING CODE



NATIONAL SANITATION FOUNDATION



UNDERWRITERS LABORATORY



TRUESDAIL LABORATORIES



TÜV RHEINLAND



NATIONAL BOARD OF BOILER & PRESSURE VESSEL INSPECTORS



FACTORY MUTUAL



INTERNATIONAL CODE COUNCIL



AMERICAN NATIONAL STANDARDS INSTITUTE



MANUFACTURERS STANDARDIZATION SOCIETY

"Apollo"[®]

Wow!

**NEW
PRODUCTS**

58A / 58B SERIES
BALANCING VALVES



The Apollo® 58 Series is a fixed orifice balance, service, and commissioning valve. The simplicity of the design and the high quality manufacturing makes the Apollo® 58 Series a simple choice for easy system balancing.

The Apollo® 58 Series is used for proportionally balancing heating and cooling systems, ensuring the required flow is correct, keeping people comfortable and helping the efficiency of your HVAC systems. Typical applications include any hydronic HVAC system installed in a range of locations including schools, hospitals, and multi-story high rise buildings.

58A

- Sizes 1/2" - 2"
- NPT, Solder, Press, Push, Pex Connections

58B

- Sizes 2-1/2" - 12"
- Flanged Connection

LD141 SERIES
LARGE DIAMETER BUTTERFLY VALVE



The large diameter Apollo International™ LD141 Series Ductile Iron Butterfly Valves are ideal for use in Industrial and Commercial/HVAC/Mechanical applications. The LD141 Series is lug style butterfly valve. Available in sizes 28" - 48".

- Compatible with ANSI 125# & 150# Flanges
- ISO 5211 Top Plate Allows Choice of Apollo® Pneumatic Actuators and Gear Operators
- Conforms to MSS SP-67 & API 609

APOLLO® POWERPRESS
CARBON STEEL PRESS VALVES & FITTINGS



Apollo® POWERPRESS is a press and fitting system designed for thick wall steel pipe as defined by ASTM A53, A106, A135, A795 (sch. 10 to 40) standards.

Apollo® POWERPRESS products are manufactured using advanced fully automated modern machinery. This ensures a consistent, safe, high quality product. 100% of welded components undergo a leak test ensuring issue free installations in the field. In addition, all straight connectors with threaded ends are made from a single piece, thus eliminating potential leaks.

The Apollo® POWERPRESS system offers a complete solution with a wide range of flexibility. The system can be utilized on standard steel pipe and can be used with different brands of press tools.

See Piping Systems Catalog (TPSICAT) for more information and specifications.

- Size Range: 1/2" to 2"
- Simple, Fast Connections
- Compact Fittings for Recessed Work
- Visual Press Indicator
- Materials of Construction Clearly Identified
- Leak Before Press® Feature (Ensures Visible Leakage of Non-Pressed Fittings)
- Suitable for Heating, Cooling, Sprinkler and Gas Installations
- Expanding Line of Integrated Valves (Eliminates the Need for Adapters and Minimizes Potential Leak Paths)
- Approvals Include: CSA, FM, IAPMO, CRN, UL, ULC/ORD, UPC, IPC, IFGC & National Plumbing Code of Canada

PRE-LF (36ELF) SERIES
WATER PRESSURE REDUCING VALVES



The Apollo® 36ELF-G is designed for residential and commercial applications to protect water supplies from excessive pressure. Excellent flow performance at low pressure drop. The 36ELF-G has a built in gauge that shows the downstream pressure. The dezincification resistant bronze body and dielectric polymer cage provide maximum corrosion resistance. Designed for easy in-line servicing with simple cartridge removal. They meet ASSE 1003 and CSA B356 standards. They are listed with IAPMO and the city of Los Angeles.

TPK
TAILPIECE KITS



Tail Piece Kits to fit 36E and 36ELF water pressure reducing valves, sizes 1/2" - 2". Each kit comes with one union nut, tailpiece and washer. Available tailpieces are FNPT (threaded), solder, press, CPVC and PEX connections. Tailpiece Kits allow for flexibility and customizing without the inventory investment of complete finished valves.

77C-A SERIES
BALL VALVE



The next generation Apollo® 77C-A "Contractor Series" full port bronze ball valve incorporates all the popular features of the original 77C series while adding thicker seats, stronger lever handles, improved stem packing adjustment, strengthened retainer sealing and 150 SWP markings. Proudly Made in the USA. Sizes 1/4" - 2 1/2".

77CLF-A SERIES
BALL VALVE



The next generation Apollo® 77CLF-A "Contractor Series" full port lead free bronze ball valve incorporates all the popular features of the original 77CLF series while adding thicker seats, stronger lever handles, improved stem packing adjustment, strengthened retainer sealing and 150 SWP markings. Proudly Made in the USA. Sizes 1/4" - 2-1/2". Certified NSF/ANSI 61 and 372, and IAPMO approved.

YCF SERIES
CLASS 125 WYE STRAINER



Steam Rated

Lead Free

The new Apollo International™ YCF Wye Strainers are now available in lead free (epoxy coating that conform to FDA CFR21, Section 175.300 and NSF/ANSI 372 Lead Free) and non-lead free (steam rated) models.

DCAP SERIES

DUAL CHECK W/ ATMOSPHERIC PORT BACKFLOW PREVENTER



The new Apollo® DCAP Series Backflow Preventer is designed to protect residential and commercial water supply lines from back-siphonage or back-pressure of non-potable (non-hazardous) substances. It has an intermediate atmospheric vent to insure protection from backflow conditions. It consists of two independently acting and spring-loaded check valves in a corrosion resistant material. Lead free option available.

US Patent Pending | Sizes 1/2", 3/4"

NEW PRODUCTS

FFB (35-603-BF) SERIES

COMBINATION BACKFLOW PREVENTER/FEED REGULATOR



35-603-BF Series offers positive protection against backflow when supply pressure falls below system pressure.

- New Design Dual Check With Atmospheric Port (DCAP) Backflow Device
- Designed for Continuous Pressure, Hot or Cold Water Service
- Fast-Fill Lever on Regulator
- Built In Stainless Steel Strainer
- Maximum Supply Pressure: 100 Psig
- Maximum Temperature: 210°F
- Backflow Device is ASSE and CSA Listed

GATE, GLOBE & CHECK VALVES

CAST IRON



The new Apollo International™ cast iron gate, globe and check valves provide full flow capabilities. These valve can reliably be installed in plumbing and heating systems (or building service piping). Valves are MSS SP-70 compliant and -LF models include NSF lead free certifications.

Now third party certified NSF/ANSI 61 Water Quality and NSF/ANSI 372 Lead Free

215, 230, 260 SERIES

HIGH PERFORMANCE BUTTERFLY VALVES



*stainless steel



Apollo International™ 215, 230, 260 Series double offset high performance butterfly valves are available in wafer or lug body design. Series 215 (Class 150) 2"-30", Series 230 (Class 300) 2"-24" and Series 260 (Class 600) 2" - 12". Available materials include WCB carbon steel or NSF/ANSI 61 and 372 certified lead free CF8M stainless steel.

"Apollo"®

BRONZE BALL VALVES

77C-100/200-A	B-3
77CLF-100/200-A	B-4
70-100/200	B-5
70LF-100/200	B-6
70-100/200-HC	B-7
70LF-100/200-HC	B-7
70B-140	B-7
70-300/400	B-8
70LF-300/400	B-8
77CLF-300	B-8
70-600	B-9
70-800	B-9
70LF-800	B-9
70-900	B-10
32-100	B-10
77-100	B-13
71-500	B-13
75-100-41	B-15
77-100	B-15
77-200	B-16
77-900	B-16
77D-140	B-17
7K-100	B-17
7K-SV	B-18
78-260	B-18
78-290	B-18
78-130	B-19
78-620	B-19
78-660/962	B-19
9A-100	B-20
82-100/200	B-20
82LF-100/200	B-21
80-100	B-25
90-100	B-25
77G-UL	B-26
51GB	B-27
50GB	B-28
78-124/125	B-29
78-256	B-29

STEEL/STAINLESS BALL VALVES

73A-100	B-14
76F-100-A	B-14

CAST IRON BALL VALVES

6PLF	B-24
------	------

BRASS BALL VALVES

51GF	B-27
94MBV	B-24
77F-100/200	B-30
77FLF-100/200	B-30
79-700	B-20
94A-100/200	B-31
94ALF-100/200	B-32
95ALF-100/200	B-33

PRESS/PEX BALL VALVES

77W-100	B-34
77WLF-100	B-34
77W-HC	B-35
77WLF-HC	B-35
77V-100	B-35
77VLF	B-36
94VLF-A	B-37
94XLF	B-37

HANDLE OPTIONS	B-11, B-12
MED GAS VALVES	B-22, B-23

BALL VALVES

APOLLO® NUMBERING SYSTEM FORMULA: 70 - 105 - 01

BALL VALVES

New!

XX	-	X	X	X	- XX
SERIES		CONFIGURATION	VARIATIONS	SIZE*	OPTIONS
32		1 - FNPT	4 - 316 STAINLESS STEEL BALL & STEM	1 - 1/4"	-01 - STANDARD
50		2 - SOLDER		2 - 3/8"	-02 - GROUNDED
51		3 - UNION END NPT	9 - PINNED RETAINER	3 - 1/2"	-04 - 2-1/4" STEM EXTENSION
6PLF		6 - 3-WAY NPT		4 - 3/4"	-07 - TEE HANDLE
		7 - FULL PORT REFRIGERATION VALVE		5 - 1"	-08 - 90° REVERSED STEM
70				6 - 1-1/4"	-10 - STAINLESS STEEL LEVER & NUT
70HC		8 - MALE X FNPT		7 - 1-1/2"	-11 - THERMA-SEAL™ INSULATING HANDLE
70LF		9 - 3-WAY SOLDER		8 - 2"	-12 - STAMPED "I57 SWP" & BAGGED
70LFHC				9 - 2-1/2"	-13 - STAMPED "I57 SWP"
71				0 - 3"	-14 - SIDE VENTED BALL (UNI-DIRECTIONAL)
75				A - 4"	-15 - ROUND HANDLE, STEEL
77					-16 - CHAIN LEVER - VERTICAL
77C-A					-17 - ROUGH CHROME PLATED
77CLF -A					-18 - PLAIN YELLOW GRIP
77C-ULA					-19 - LOCK PLATE
77D					-20 - SLOT VENTED BALL (BI-DIRECTIONAL)
					-21 - UHMWPE TRIM (NON-PTFE)
77F					-24 - GRAPHITE PACKING
77FLF					-27 - STAINLESS STEEL LATCH-LOCK LEVER & NUT
77G-UL					-30 - CAM-LOCK AND GROUNDED
77V					-32 - STAINLESS STEEL TEE HANDLE & NUT
77VLF					-35 - VTFE TRIM (PTFE)
77W					-36 - STAINLESS STEEL HI-RISE ROUND HANDLE, STAINLESS STEEL NUT
77WLF					-39 - SS HI-RISE LOCKING ROUND HANDLE, SS NUT
77W -HC					-40 - CYL-LOC AND GROUNDED
77WLF-HC					-41 - AUTOMATIC DRAIN
78					-45 - LESS LEVER AND NUT
79					-46 - LATCH-LOCK LEVER - LOCK IN CLOSED POSITION ONLY
77B					-47 - SS OVAL LATCH-LOCK HANDLE & NUT
7K					-48 - SS OVAL HANDLE (NO LATCH) & NUT
80					-49 - ASSEMBLED DRY
82					-50 - 2-1/4" CARBON STEEL LOCKING STEM EXT.
82LF					-56 - MULTIFILL SEATS & PACKING
89FV					-57 - OXYGEN CLEANED
9A					-58 - CHAIN LEVER - HORIZONTAL
90					-59 - SS EXTERNAL TRIM: 3-PC & FLANGED VALVES
94A					-60 - GROUNDED BALL & STEM
94ALF-A					-62 - BODY CENTER SECTION (82 SERIES)
94MBV					-63 - NPT X SOLDER (-100-63-NPT BODY / -200-63-SWEAT BODY)
94XLF					-64 - 250 SWP
94VLF-A					-65 - MULTIFILL SEATS & GRAPHITE PACKING
95ALF					-72 - RTFE PACKING
					-91 - LOCKING SS TEE (3/4" AND 1")
					-92 - BALANCING STOP
					-94 - -04 & BALANCING STOP
					-BC - BALL CHECK
					-HC - HOSE THREAD AND CAP OPTION
					-SV - SAFETY VENT - 77-100/7K-100 SERIES (AUTO DRAIN)
					-SW - LIMIT SWITCH MOUNTED
					-TH - TESTED, HYDROSTATIC
					-TC - TESTED, HYDROSTATIC, W/CERTIFICATION
					-TW - TESTED, HYDROSTATIC, W/WITNESS & CERT.



77C-100/200-A SERIES

CONTRACTOR SERIES FULL PORT BRONZE BALL VALVE WITH SOLID BALL

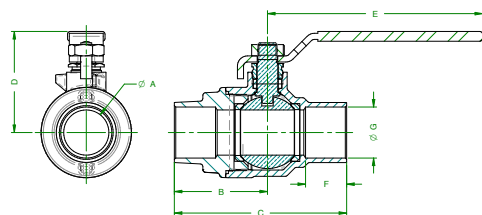
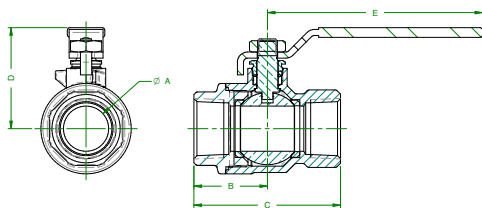

Apollo's solid ball design delivers true full-port performance with 100% American construction. The next generation mod -"A" adds a new beefier lever, simplified packing adjustment, wider seats and stem packing and a 150 SWP body marking.

FEATURES

- ASTM Grade Bronze Castings
- Solid Brass Ball, Plated
- 600 psig CWP, Non-Shock
- 150 SWP Steam Rating
- Generous RPTFE Seats and Stem Packing
- Adjustable Stem Packing
- Blowout-Proof Stem Design
- Vacuum Service to 29 in. Hg
- Full-Port Design Through 2-1/2"
- ANSI B16.18 Solder End Version Available as 77C-200 Series
- CSAB51-CRN OC10908.5C
- MSS SP-110 Compliant
- IAPMO R&T / UPC-IGC Z1157
- **Proudly Made in USA**

OPTIONS*

- (-01) Standard Lever and Trim
- (-04) 2-1/4" Stem Extension
- (-07) CS Tee Handle
- (-10) Stainless Steel Handle and Nut
- (-11) Therma-Seal™ Insulating Tee
- (-27) Locking Handle
- (-50) 2-1/4" Locking Stem Extension
- (-92) Balancing Stop
- (-94) 2-1/4" Stem Extension and Balancing Stop
- Reversible Handle Option
- SS Vented Ball and Stem (77C140 and 77C240 Series)
- **77C-ULA UL258 Fire Protection Trim & Drain Option *NEW!***
- Flammable Gas Listed (CSA & UL) Model 77G-UL (See Page B-26)
- Other Handle Options Available

Also Available in a Lead Free Version as the 77CLF-A Series

Lever option kits for the 77C and 77C-A models differ. Refer to the latest Apollo® kit listing or contact Apollo® Tech Support for assistance.

DIMENSIONS

PART NO.	SIZE (IN.)	DIMENSIONS (IN.)							C _v	WT. * (LB.)
		A	B	C	D	E	F	G		
NPT										
77C-101-01A	1/4"	0.37	0.88	1.8	1.65	2.82	-	-	5	0.6
77C-102-01A	3/8"	0.37	0.94	1.86	1.65	2.82	-	-	7	0.6
77C-103-01A	1/2"	0.50	1.15	2.29	1.79	3.82	-	-	16	0.6
77C-104-01A	3/4"	0.75	1.34	2.67	1.91	3.82	-	-	36	1.0
77C-105-01A	1"	1.00	1.63	3.24	2.24	4.72	-	-	68	1.8
77C-106-01A	1-1/4"	1.25	1.9	3.75	2.46	4.72	-	-	125	4.2
77C-107-01A	1-1/2"	1.50	2.06	4.11	2.9	5.37	-	-	177	4.6
77C-108-01A	2"	2.00	2.43	4.85	3.68	7.72	-	-	389	7.9
77C-109-01A	2-1/2"	2.50	3.03	6.02	4.13	7.72	-	-	503	16.4
SOLDER										
77C-202-01A	3/8"	0.37	1.24	2.17	1.65	2.82	0.41	0.50	7	0.6
77C-203-01A	1/2"	0.50	1.36	2.47	1.79	3.82	0.50	0.63	16	0.6
77C-204-01A	3/4"	0.75	1.73	3.20	1.91	3.82	0.75	0.88	36	1.0
77C-205-01A	1"	1.00	2.06	3.81	2.24	4.72	0.91	1.13	68	1.5
77C-206-01A	1-1/4"	1.25	2.22	4.21	2.46	4.72	0.97	1.38	125	3.9
77C-207-01A	1-1/2"	1.50	2.53	4.90	2.9	5.37	1.09	1.63	177	5.9
77C-208-01A	2"	2.00	3.15	6.07	3.68	7.72	1.34	2.13	389	7.5
77C-209-01A	2-1/2"	2.50	3.78	7.17	4.13	7.72	1.48	2.63	503	14.5

**Weights based on Standard Configuration*

BALL VALVES

77CLF-100/200-A SERIES
CONTRACTOR SERIES FULL PORT BRONZE BALL VALVE WITH SOLID BALL

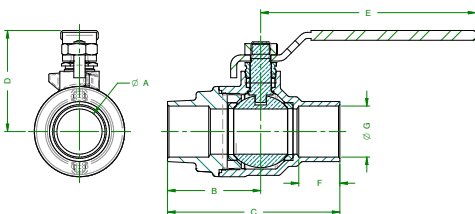
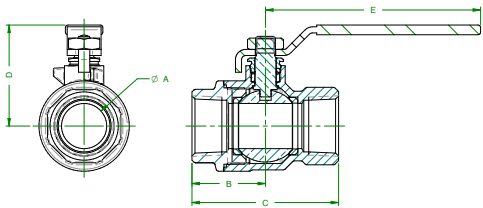

Apollo's solid ball design delivers true full-port performance with 100% American construction. The next generation mod -"A" adds a new beefier lever, simplified packing adjustment, wider seats and stem packing and a 150 SWP body marking.

FEATURES

- ASTM Grade Lead Free Bronze Castings
- Solid Brass Ball, Plated
- 600 psig CWP, Non-Shock
- 150 SWP Steam Rating
- Generous RPTFE Seats and Stem Packing
- Adjustable Stem Packing
- Blowout-Proof Stem Design
- EZ-Solder™ Lead Free Bronze
- Vacuum Service to 29 in. Hg
- Full-Port Design Through 2-1/2"
- ANSI B16.18 Solder End Version Available as 77C-200 Series
- CSAB51-CRN OC10908.5C
- NSF/ANSI 61 Water Quality
- NSF/ANSI 372 Lead Free
- MSS SP-110 Compliant
- IAPMO R&T / UPC-IGC Z1157
- **Proudly Made in USA**

OPTIONS*

- (-01) Standard Lever and Trim
- (-04) 2-1/4" Stem Extension
- (-07) CS Tee Handle
- (-10) Stainless Steel Handle and Nut
- (-11) Therma-Seal™ Insulating Tee
- (-27) Locking Handle
- (-50) 2-1/4" Locking Stem Extension
- (-92) Balancing Stop
- (-94) 2-1/4" Stem Extension and Balancing Stop
- Reversible Handle Option
- SS Vented Ball and Stem (77C140 and 77C240 Series)
- **77C-ULA UL258 Fire Protection Trim & Drain Option NEW!**
- Flammable Gas Listed (CSA & UL) Model 77G-UL (See Page B-26)
- Other Handle Options Available
- Also Available in Standard Bronze as the 77C-A Series

**Lever option kits for the 77C and 77C-A models differ. Refer to the latest Apollo® kit listing or contact Apollo® Tech Support for assistance.*

DIMENSIONS

PART NO.	SIZE (IN.)	DIMENSIONS (IN.)							C _v	WT. * (LB.)
		A	B	C	D	E	F	G		
NPT										
77CLF-101-01A	1/4"	0.37	0.88	1.8	1.65	2.82	-	-	5	0.6
77CLF-102-01A	3/8"	0.37	0.94	1.86	1.65	2.82	-	-	7	0.6
77CLF-103-01A	1/2"	0.50	1.15	2.29	1.79	3.82	-	-	16	0.6
77CLF-104-01A	3/4"	0.75	1.34	2.67	1.91	3.82	-	-	36	1.0
77CLF-105-01A	1"	1.00	1.63	3.24	2.24	4.72	-	-	68	1.8
77CLF-106-01A	1-1/4"	1.25	1.9	3.75	2.46	4.72	-	-	125	4.2
77CLF-107-01A	1-1/2"	1.50	2.06	4.11	2.9	5.37	-	-	177	4.6
77CLF-108-01A	2"	2.00	2.43	4.85	3.68	7.72	-	-	389	7.9
77CLF-109-01A	2-1/2"	2.50	3.03	6.02	4.13	7.72	-	-	503	16.4
SOLDER										
77CLF-202-01A	3/8"	0.37	1.24	2.17	1.65	2.82	0.41	0.50	7	0.6
77CLF-203-01A	1/2"	0.50	1.36	2.47	1.79	3.82	0.50	0.63	16	0.6
77CLF-204-01A	3/4"	0.75	1.73	3.20	1.91	3.82	0.75	0.88	36	1.0
77CLF-205-01A	1"	1.00	2.06	3.81	2.24	4.72	0.91	1.13	68	1.5
77CLF-206-01A	1-1/4"	1.25	2.22	4.21	2.46	4.72	0.97	1.38	125	3.9
77CLF-207-01A	1-1/2"	1.50	2.53	4.90	2.9	5.37	1.09	1.63	177	5.9
77CLF-208-01A	2"	2.00	3.15	6.07	3.68	7.72	1.34	2.13	389	7.5
77CLF-209-01A	2-1/2"	2.50	3.78	7.17	4.13	7.72	1.48	2.63	503	14.5

**Weights based on Standard Configuration*



**70-100/200 SERIES
BRONZE BALL VALVE**

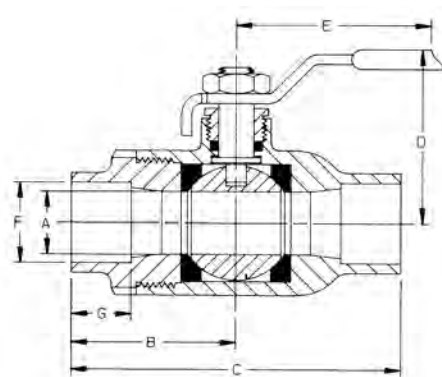
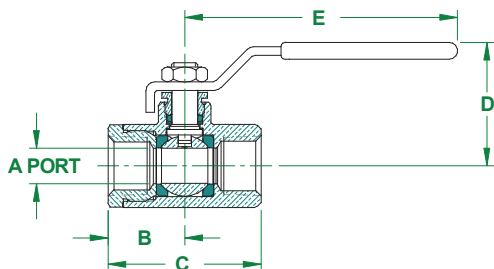

The Apollo® 70 Series is the most widely used and trusted bronze ball valve in the industry. It features blowout-proof stem, RPTFE seats and stuffing box ring and plated brass ball.

FEATURES

- Heavy Pattern Construction
- Rated 600 psig CWP, Non-Shock
- 150 psig for Saturated Steam
- Optional 250 SWP Configuration
- Vacuum Service to 29 in. Hg
- Adjustable Packing Gland
- Multiple Options and Configurations Available
- Lead Free Option (70LF)
- 100% Tested
- **Proudly Made in USA**

DIMENSIONS

PART NUMBER	SIZE (IN.)	DIMENSIONS (IN.)					WT. (LB.)
		A	B	C	D	E	
NPT							
70-101-01	1/4"	0.37	1.03	2.06	1.75	3.87	0.60
70-102-01	3/8"	0.37	1.03	2.06	1.75	3.87	0.56
70-103-01	1/2"	0.50	1.12	2.17	1.75	3.87	0.63
70-104-01	3/4"	0.68	1.50	3.00	2.12	4.87	1.39
70-105-01	1"	0.87	1.68	3.37	2.25	4.87	1.72
70-106-01	1-1/4"	1.00	2.00	4.00	2.62	5.50	3.26
70-107-01	1-1/2"	1.25	2.18	4.37	3.06	8.00	4.61
70-108-01	2"	1.50	2.34	4.68	3.25	8.00	6.06
70-109-01A	2-1/2"	2.00	3.12	6.25	3.72	8.00	17.25
70-100-01	3"	2.50	3.37	6.75	4.12	8.00	18.60
70-10A-01	4"	3.12	3.68	7.37	5.25	10.00	25.50

NOTE: 1/4", 3/8", and 1/2" are full port.

DIMENSIONS

PART NUMBER	SIZE (IN.)	DIMENSIONS (IN.)*						
		A	B	C	D	E	F	G
SOLDER								
70-202-01	3/8"	0.37	1.28	2.56	1.75	3.87	0.505	0.37
70-203-01	1/2"	0.50	1.43	2.87	1.75	3.87	0.63	0.50
70-204-01	3/4"	0.68	1.93	3.87	2.12	4.87	0.88	0.75
70-205-01	1"	0.87	2.25	4.50	2.25	4.87	1.13	0.90
70-206-01	1-1/4"	1.00	2.31	4.62	2.62	5.50	1.38	0.96
70-207-01	1-1/2"	1.25	2.62	5.25	3.06	8.00	1.63	1.09
70-208-01	2"	1.50	3.18	6.37	3.25	8.00	2.13	1.34
70-209-01A	2-1/2"	2.00	3.74	7.51	3.72	8.00	2.63	1.48
70-200-01	3"	2.50	4.12	8.25	4.12	8.00	3.13	1.67
70-20A-01	4"	3.12	4.61	9.22	5.22	9.94	4.13	2.16

*Based on 70-200-01 - Dimensions may vary with options.

NOTE: 1/4", 3/8", and 1/2" are full port.

**70-2xx intended for soft solder installation using solders with melting temperature of < 500°F.

BALL VALVES

**70LF-100/200 SERIES
BRONZE BALL VALVE**



BALL VALVES

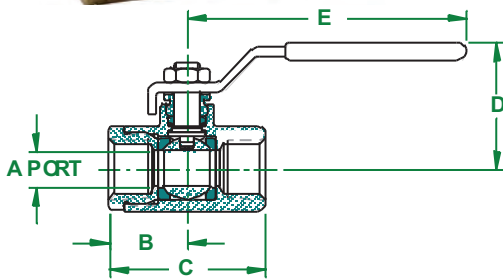

The Apollo® 70LF series is the most widely used and trusted lead free bronze ball valve in the industry. It features a blowout-proof stem, RPTFE seats and stuffing box ring and plated brass ball.

FEATURES

- Heavy Pattern Construction
- EZ-Solder™ Lead free bronze
- Solders Just Like Standard Bronze
- Rated 600 psig CWP, Non-Shock
- 150 psig for Saturated Steam
- 100% Factory Tested
- Vacuum Service to 29 in. Hg
- NSF/ANSI 61 Water Quality
- NSF/ANSI 372 Lead Free
- Adjustable Packing Gland
- Multiple Options and Configurations Available

DIMENSIONS

PART NUMBER	SIZE (IN.)	DIMENSIONS (IN.)					WT. (LB.)
		A	B	C	D	E	
NPT							
70LF-101-01	1/4"	0.37	1.03	2.06	1.75	3.87	0.60
70LF-102-01	3/8"	0.37	1.03	2.06	1.75	3.87	0.56
70LF-103-01	1/2"	0.50	1.12	2.25	1.75	3.87	0.63
70LF-104-01	3/4"	0.68	1.50	3.00	2.12	4.87	1.39
70LF-105-01	1"	0.87	1.68	3.37	2.25	4.87	1.72
70LF-106-01	1-1/4"	1.00	2.00	4.00	2.62	5.50	3.26
70LF-107-01	1-1/2"	1.25	2.18	4.37	3.06	8.00	4.61
70LF-108-01	2"	1.50	2.34	4.68	3.25	8.00	6.06
70LF-109-01	2-1/2"	2.00	3.12	6.25	3.72	8.00	13.96
70LF-100-01	3"	2.50	3.37	6.75	4.12	8.00	18.60
70LF-10A-01	4"	3.12	3.68	7.37	5.25	10.00	25.50

NOTE: 1/4", 3/8", and 1/2" are full port.

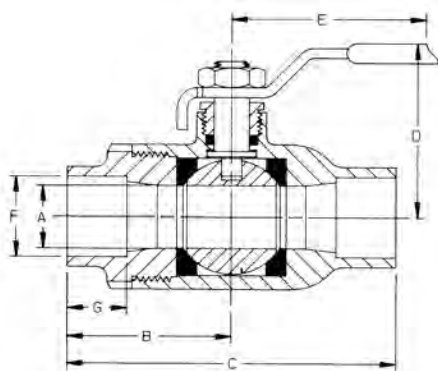

DIMENSIONS

PART NUMBER	SIZE (IN.)	DIMENSIONS (IN.)*						
		A	B	C	D	E	F	G
SOLDER								
70LF-202-01	3/8"	0.37	1.28	2.56	1.75	3.87	0.505	0.37
70LF-203-01	1/2"	0.50	1.43	2.87	1.75	3.87	0.63	0.50
70LF-204-01	3/4"	0.68	1.93	3.87	2.12	4.87	0.88	0.75
70LF-205-01	1"	0.87	2.25	4.50	2.25	4.87	1.13	0.90
70LF-206-01	1-1/4"	1.00	2.31	4.62	2.62	5.50	1.38	0.96
70LF-207-01	1-1/2"	1.25	2.62	5.25	3.06	8.00	1.63	1.09
70LF-208-01	2"	1.50	3.18	6.37	3.25	8.00	2.13	1.34
70LF-209-01A	2-1/2"	2.00	3.74	7.51	3.72	8.00	2.63	1.48
70LF-200-01	3"	2.50	4.12	8.25	4.12	8.00	3.13	1.67
70LF-20A-01	4"	3.12	4.61	9.22	5.22	9.94	4.13	2.16

*Based on 70-200-01 - Dimensions may vary with options.

NOTE: 1/4", 3/8", and 1/2" are full port.

**70LF-2xx intended for soft solder installation using solders with melting temperature of < 500°F.



70-HC SERIES
HOSE CAP & CHAIN VALVE

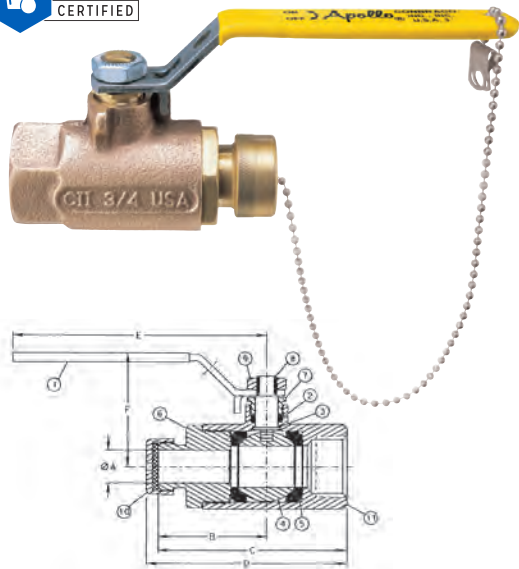

CAP & CHAIN VALVE WITH 3/4" HOSE CONNECTION, HEAVY BRASS CAP AND REVERSE HANDLE

Ideally suited for draining or sampling of HVAC or potable water systems, these valves allow direct connections to hoses. Valve features a securely attached cover (includes chain) which prevents damage to hose threads. -200 model designed for soft soldering into lines without disassembly.

FEATURES

- Heavy Pattern Construction
- Reverse Lever is Standard for Easier Installation
- Stainless Steel Lever & Nut Standard
- NPT and Solder Connections
- EZ-Solder™ Lead free bronze
- ASTM B584 Bronze
- Blowout-Proof Stem Design
- RPTFE Seats and Stuffing Box Ring
- Adjustable Packing Gland
- Vacuum Service to 29 in. Hg
- Maximum Pressure: 600 psi CWP
- Temperature Rating: 200°F
- Full Pressure Rated Brass Hose Cap
- **Stronger Stainless Steel Ball Chain** **NEW!**

OPTIONS

- (-11) Therma-Seal™ Insulating Tee
- Stainless Steel Ball and Stem (70-24x-HC/70LF-24X-HC)
- 70LF is NSF 61 and NSF 372 Certified Lead Free

DIMENSIONS

MODEL NUMBER	LF MODEL NUMBER	SIZE (IN.)	DIMENSIONS (IN.)					
			A	B	C	D	E	F
70-103-HC	70LF-103-HC	1/2 NPT x 3/4 Hose	0.50	1.68	2.81	2.97	3.87	1.75
70-104-HC	70LF-104-HC	3/4 NPT x 3/4 Hose	0.68	1.96	3.50	3.67	4.87	2.12
70-105-HC	70LF-105-HC	1 NPT x 3/4 Hose	0.87	2.24	3.92	4.16	5.28	2.43
70-203-HC	70LF-203-HC	1/2 Solder x 3/4 Hose	0.50	1.68	3.14	3.28	3.89	1.75
70-204-HC	70LF-204-HC	3/4 Solder x 3/4 Hose	0.68	1.96	3.94	4.09	4.89	2.12
70-205-HC	-	1 Solder x 3/4 Hose	0.87	2.24	4.49	4.73	5.28	2.43

70B-140 SERIES
STEAM BOILER/B31.1 POWER PIPING BRONZE BALL VALVE



The Apollo® 70B series has the same rugged features as the standard 70 series valve but with ASTM B62 bronze shell components. The 70B has trusted performance along with a wide range of options to suit every application.

FEATURES

- Stainless Steel Ball & Stem
- Blowout-Proof Stem Design
- Adjustable Packing Gland
- MPTFE Seats and Stuffing Box Ring
- 100% Factory Tested
- 85-5-5 Retainer & Body

PERFORMANCE RATING

- Maximum Pressure: 600 psi CWP, 250 psi SWP
- Maximum Temperature: 500°F
- Vacuum Service to 29 in. Hg

APPROVALS

- MSS SP-110 - Ball Valves
- CRN: OC10908.5C
- ASME B31.1 - Power Piping

DIMENSIONS

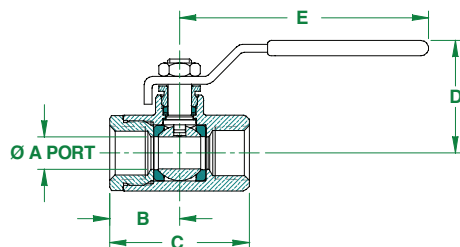

MODEL NUMBER	SIZE (IN.)	DIMENSIONS					WT. (LB.)
		A	B	C	D	E	
70B-141-64	1/4"	0.37	1.03	2.06	1.75	3.87	0.60
70B-142-64	3/8"	0.37	1.03	2.06	1.75	3.87	0.56
70B-143-64	1/2"	0.50	1.12	2.25	1.75	3.87	0.63
70B-144-64	3/4"	0.68	1.50	3.00	2.12	4.87	1.39
70B-145-64	1"	0.87	1.68	3.37	2.25	4.87	1.72
70B-146-64	1-1/4"	1.00	2.00	4.00	2.62	5.50	3.26
70B-147-64	1-1/2"	1.25	2.18	4.37	3.06	8.00	4.61
70B-148-64	2"	1.50	2.34	4.68	3.25	8.00	6.06

70-300/400 SERIES
BALL VALVE WITH FNPT X UNION END

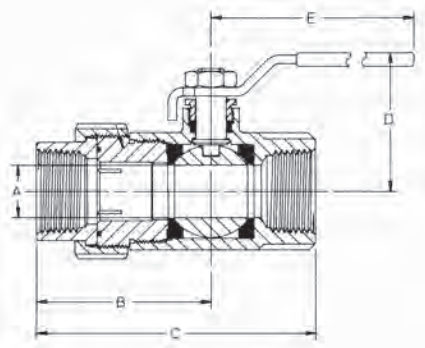

This valve combines a pipe union with ball valve shut-off; it saves time and labor by eliminating the need for extra connections. Viton O-ring sealed union requires light torque for proper seal.

FEATURES

- ASTM B584 Bronze
- Blowout-Proof Stem Design
- Adjustable Packing Gland
- 600 psig CWP, Non-Shock
- NPT and Solder Union Connection
- Vacuum Service to 29 in. Hg
- 70LF-300/400 Feature EZ-Solder™ Lead Free Bronze

DIMENSIONS

MODEL NUMBER	LF MODEL NUMBER	SIZE (IN.)	DIMENSIONS (IN.)				
			A	B	C	D	E
NPT							
70-301-01	-	1/4	0.37	1.90	2.93	1.75	3.87
70-302-01	-	3/8	0.37	1.90	2.93	1.75	3.87
70-303-01	70LF-303-01	1/2	0.50	2.00	3.09	1.75	3.87
70-304-01	70LF-304-01	3/4	0.68	2.46	3.96	2.12	4.87
70-305-01A	70LF-305-01A	1	0.87	2.84	4.52	2.25	4.87
70-306-01	70LF-306-01	1-1/4	1.00	2.68	4.68	2.62	5.50
70-307-01	70LF-307-01	1-1/2	1.25	2.87	5.06	3.05	8.00
70-308-01	70LF-308-01	2	1.50	3.25	5.59	3.24	8.00
SOLDER							
70-403-01	-	1/2	0.50	2.00	3.43	1.75	3.87
70-404-01	70LF-404-01	3/4	0.68	2.62	4.56	2.06	4.78
70-405-01A	70LF-405-01A	1	0.87	2.87	5.66	2.25	4.78
70-406-01	70LF-406-01	1-1/4	1.00	2.87	5.18	2.62	5.50
70-407-01	70LF-407-01	1-1/2	1.25	2.92	5.53	3.10	8.00
70-408-01	70LF-408-01	2	1.50	3.50	6.75	3.24	8.00

NOTE: 1/4", 3/8", and 1/2" are full port.

77CLF-300-A SERIES
FULL PORT BALL VALVE WITH FNPT X UNION END

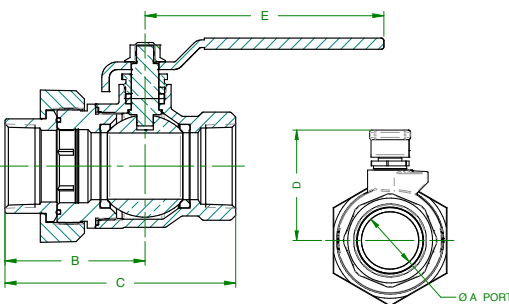

The Apollo® 77CLF300 Series Union End Ball Valve features dezincification resistant lead free bronze body, generously sized RPTFE seats and stem packing, and a lead free "Solid Ball" design that delivers true full-port flow performance.

FEATURES

- Lead Free Brass & Bronze Materials Easily Identifiable Blue "Lead Free" Hang Tag
- Reinforced RPTFE Seats & Seals
- **Manufactured and 100% Factory Tested in USA**

PERFORMANCE RATING

- Maximum Pressure: 600 psi CWP
- Maximum Temperature: 180°F
- Vacuum Service to 29 in. Hg

APPROVALS

- MSS SP-110 - Ball Valves
- NSF/ANSI 61 Water Quality
- NSF/ANSI 372 Lead Free
- CRN: OC10908.5C

OPTIONS

- (-01) Standard Lever
- (-04) 21/4" Stem Extension
- (-07) Tee Handle
- (-10) S.S. Handle and Nut
- (-11) Therma-Seal™ Insulating Tee Handle
- (-27) Locking Handle

DIMENSIONS

PART NO.	SIZE (IN.)	DIMENSIONS (IN.)					WT (LB.)
		A	B	C	D	E	
70LF30301*	1/2	0.50	2.00	3.09	1.75	3.87	0.99
77CLF30401A	3/4	0.75	2.26	3.59	1.92	3.97	1.34
77CLF30501A	1	1.00	2.55	4.17	2.24	4.76	2.36
77CLF30601A	1-1/4	1.25	2.71	4.55	2.46	4.76	5.07
77CLF30701A	1-1/2	1.50	3.17	5.23	2.90	5.41	4.96
77CLF30801A	2	2.00	3.49	5.91	3.68	7.76	10.06

*1/2" size only is available as model 70LF300, full-port bronze construction.



70-600 SERIES
THREADED 3-WAY DIVERTER BALL VALVE

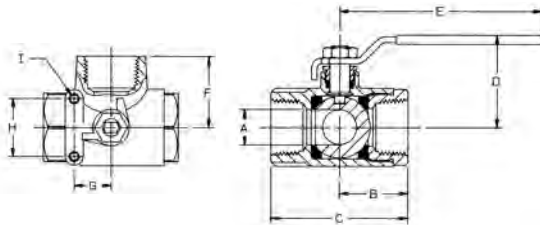

Ideal for applications requiring flow diversion, this valve combines the features of two valves. Its large ports make tank selection and fluid transfers quicker and easier. Easy quarter-turn operation.

FEATURES

- Simple Quarter-Turn Operation
- ASTM B584 Bronze
- 400 psig CWP, Non-Shock
- Blowout-Proof Stem
- Adjustable Stem Packing
- Vacuum Service to 29 in. Hg
- See 70-900 for Solder Version

DIMENSIONS

MODEL NUMBER	SIZE (IN.)	DIMENSIONS (IN.)								
		A	B	C	D	E	F	G	H	I
70-601-01	1/4	0.37	1.12	2.32	1.80	3.88	1.18	0.875	1.37	10-24
70-602-01	3/8	0.37	1.12	2.32	1.80	3.88	1.18	0.875	1.37	10-24
70-603-01	1/2	0.50	1.09	2.25	1.75	3.87	1.18	0.87	1.37	10-24
70-604-01	3/4	0.68	1.50	3.00	2.12	4.87	1.62	0.87	1.37	10-24
70-605-01	1	0.81	1.59	3.18	2.25	4.87	1.71	0.87	1.37	10-24
70-606-01	1-1/4	1.00	1.97	3.95	2.69	5.50	2.01	0.93	1.50	1/4-20
70-607-01	1-1/2	1.25	2.21	4.40	2.87	5.50	2.38	0.94	1.50	1/4-20
70-608-01	2	1.50	2.34	4.69	3.00	5.50	2.50	0.94	1.50	1/4-20

70-800 SERIES
MALE X FEMALE NPT BALL VALVE

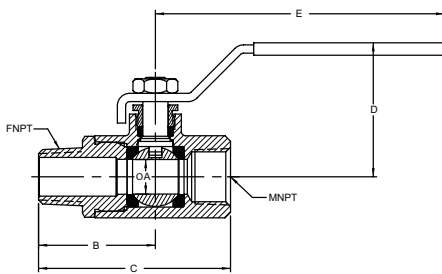

Eliminates need for extra nipple when connecting to female connection to save time and labor. Ruggedly built for lasting performance with chromium-plated ball and blowout-proof stem.

FEATURES

- 600 psig CWP, Non-Shock
- 150 SWP Steam Rating
- RPTFE Seats and Stuffing Box Ring
- Adjustable Stem Packing
- Vacuum Service to 29 in. Hg

DIMENSIONS

MODEL NUMBER	LF MODEL NUMBER	SIZE (IN.)	DIMENSIONS (IN.)				
			A	B	C	D	E
70-801-01	-	1/4	0.37	1.40	2.43	1.75	3.87
70-802-01	-	3/8	0.37	1.46	2.50	1.75	3.87
70-803-01	70LF-803-01	1/2	0.50	1.68	2.81	1.81	3.87
70-804-01	70LF-804-01	3/4	0.68	2.00	3.50	2.12	4.87
70-805-01	70LF-805-01	1	0.87	2.31	4.00	2.25	4.87
70-806-01	70LF-806-01	1-1/4	1.00	2.31	4.31	2.62	5.50
70-807-01	-	1-1/2	1.25	3.00	5.18	3.06	8.00

NOTE: 1/4", 3/8", and 1/2" are full port.

70-900 SERIES
SOLDER 3-WAY DIVERTER BALL VALVE

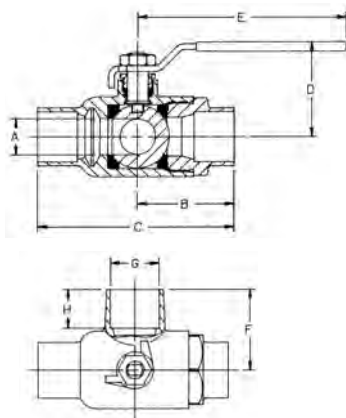
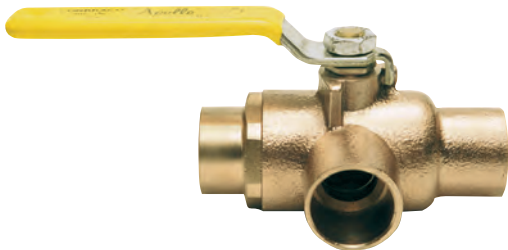

Tank selection and fluid transfers are easier because of large port diameters. The valve is 100% air tested under water. Designed to be soft soldered without disassembly.

FEATURES

- Simple Quarter-Turn Operation
- ASTM B584 Bronze
- 400 psig CWP, Non-Shock
- Blowout-Proof Stem
- Adjustable Packing
- See 70-600 for NPT Version
- **Made in USA**

DIMENSIONS

MODEL NUMBER	SIZE (IN.)	DIMENSIONS (IN.)							
		A	B	C	D	E	F	G	H
70-903-01	1/2	0.50	1.44	2.87	1.75	3.87	1.34	0.628	0.50
70-904-01	3/4	0.68	1.94	3.87	2.12	4.87	1.69	0.878	0.90
70-905-01	1	0.81	2.19	4.42	2.25	4.87	1.87	1.129	0.90

BALL VALVES

32-100 SERIES
REGULAR PORT, THREADED END, BRONZE BALL VALVE

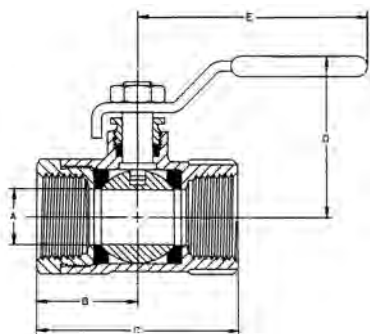

NPT threaded ball valve rated to 400 psig CWP, non-shock and 125 psig for saturated steam. Blowout-proof stem design with adjustable packing gland.

FEATURES

- ASTM B584 Bronze
- PTFE Seats and MPTFE Stuffing Box Ring
- **Made in USA**

OPTIONS

- (-04) 2-1/4" Stem Extension
- (-07) CS Tee Handle
- (-15) Round Handle
- (-27) Locking Handle

DIMENSIONS

MODEL NUMBER	SIZE (IN.)	DIMENSIONS (IN.)				
		A	B	C	D	E
32-101-01	1/4	0.37	0.80	1.60	1.65	2.87
32-102-01	3/8	0.37	0.80	1.60	1.65	2.87
32-103-01	1/2	0.40	1.00	2.00	1.68	2.87
32-104-01	3/4	0.65	1.20	2.41	1.90	3.87
32-105-01	1	0.75	1.55	3.09	2.18	4.87
32-106-01	1-1/4	1.00	1.72	3.44	2.53	5.50
32-107-01	1-1/2	1.12	1.93	3.87	2.69	5.50
32-108-01	2	1.50	2.17	4.37	2.94	5.50



COMMON BALL VALVE OPTIONS

Apollo® offers these options on the 70 Series as well as many other valve series. Note: Not all options are available on all sizes and models. Review the latest submittal sheet or contact the factory to determine availability. Most available as a factory installed option or as a kit for field installation or retrofit.

SUFFIX NO.



2-1/4"
STEM EX-
TENSION

-04

STANDARD BALL VALVE WITH STEM EXTENSION

A plated steel stem extension to accommodate 2" thick pipe insulation or to relocate handle position.



-07

TEE HANDLE

Plated steel tee handle is ideal when space is limited and where safety is a consideration. Handle still provides visual indication of OPEN or CLOSED position.



-08

90° REVERSED STEM

Used in applications when handle is required to be in a parallel position when closed.



-10

STAINLESS STEEL LEVER AND NUT

Additional corrosion resistance for damp or marine installations.



-11

THERMA-SEAL™ HANDLE (UL 2043 LISTING)

The Thermo-Seal™ thermal insulating tee-handle is designed to be use in applications where vapor barrier piping insulation is required. Manufactured from high strength glass reinforced nylon, these handles are ideally suited for the toughest commercial and industrial applications. Handles are available as a factory installed option (-11 option suffix) or as a retrofit kit. UL 2043 listed for plenum installations.



**-16/
-58**

CHAIN LEVER BALL VALVES

Reliable quarter turn operation in overhead applications. A favorite for use in industrial environments.

- -16 for valve in vertical position
- -58 for valve in horizontal position



-17

ROUGH CHROME PLATING

Use where a clean, bright finish is required or for matching up with other chrome-plated equipment.

COMMON BALL VALVE OPTIONS

BALL VALVES



-27

STAINLESS STEEL LATCH LOCK - LOCKING LEVER HANDLE

Sliding lock mechanism secures handle in open or closed position. Valve can also be padlocked open or closed.



-32/
-83

STAINLESS STEEL TEE HANDLE AND NUT

Increased corrosion resistance versus the plated steel -07 option.

- -32 for standard bronze
- -83 for 77B/77BLF



-41

BALL VALVE WITH AUTOMATIC DRAIN

When this valve is closed for maintenance of pneumatic tool, downstream pressure from valve to tool is automatically drained to atmosphere to prevent accidental operation of the tool, causing possible injury.

- Conforms to certain OSHA requirements in pneumatic installations
- Easy, safe maintenance of pneumatic tools
- Cannot be used where drained media could cause damage
- Temperature range: 50°F to 200°F
- Rated 125 psig CWP, non-shock air or water
- Includes directional arrow for correct installation
- Available with latch lock option, specify -27 -41 suffix
- Available for the following series: 70, 71, 75, and 78



-48

STAINLESS STEEL OVAL HANDLE

- Available for the following series: 70, 71, 73A, 76, 76F, 77, 82, 83, 85, 86, 89, 9A, 92 and 96
- Resistant to accidental operation



-57

CLEANED AND BAGGED FOR OXYGEN SERVICE



-64

250 SWP RATING

- Stainless steel stem
- Vented ball
- MPTFE seats and packing
- Yellow handle with red printing
- Available for the following series: 70, 71, 77



-92

MEMORY STOP HANDLE



-94

BALL VALVE WITH BALANCING STOP AND STEM EXTENSION

Ideal for HVAC systems. Stop plate and a 2-1/4" stem extension combination to accommodate insulation and handle repositioning. *Contact customer service for exact handle dimensions.*



71-100 SERIES
BALL VALVE WITH MOUNTING PAD

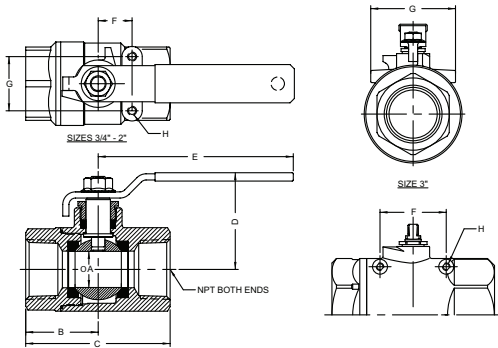
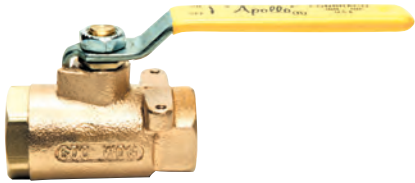

Designed to easily accommodate spring return handle, actuator or simple panel mounting. Threaded end connections with RPTFE seats and stuffing box ring.

FEATURES

- 3/4" to 3" models
(Use 77-100 Series for 1/4", 3/8" & 1/2")
- 600 CWP Non-Shock
- Blowout-Proof Stem
- ASTM B584 Bronze
- Round Handle Option
- Adjustable Packing

DIMENSIONS

MODEL NUMBER	SIZE (IN.)	DIMENSIONS (IN.)							
		A	B	C	D	E	F	G	H
77-101-01	1/4	0.43	1.09	2.18	1.77	3.87	0.50	1.12	10-24 NC
77-102-01	3/8	0.50	1.09	2.18	1.77	3.87	0.50	1.12	10-24 NC
77-103-01	1/2	0.50	1.09	2.18	1.77	3.87	0.50	1.12	10-24 NC
71-104-01	3/4	0.68	1.50	3.00	2.12	4.87	0.87	1.37	10-24 NC
71-105-01	1	0.87	1.68	3.37	2.25	4.87	0.87	1.37	10-24 NC
71-106-01	1-1/4	1.00	2.00	4.00	2.62	5.50	0.93	1.50	1/4-20 NC
71-107-01	1-1/2	1.25	2.18	4.37	2.87	8.00	0.93	1.50	1/4-20 NC
71-108-01	2	1.50	2.34	4.68	3.06	8.00	0.93	1.50	1/4-20 NC
71-100-01	3	2.50	3.37	6.75	4.12	8.00	3.37	2.75	1/4-20 NC

Actuation assistance available in Section D, with the Apollo® Actuator Wizard located at actuatorwizard.conbraco.com or by calling customer support at (704)841-6000.

71-500 SERIES
CAST BRONZE BALL VALVE SPRING RETURN HANDLE

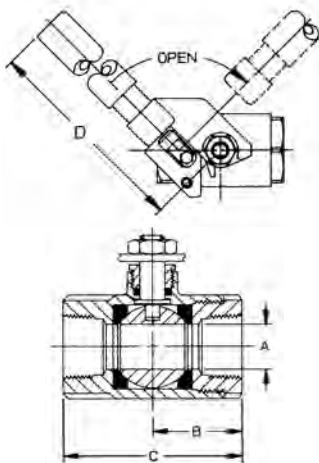

Ideal in applications where the valve must be in OFF position at all times such as sampling and feeding fuel lines. Can be used in reverse with 90° reverse stem option. Basic configuration: spring return to CLOSED. All lever components are stainless steel.

FEATURES

- Rated 600 psig CWP, Non-Shock
- 150 psig for Saturated Steam
- (-08) Spring Return to OPEN

DIMENSIONS

MODEL NUMBER	SIZE (IN.)	DIMENSIONS (IN.)			
		A	B	C	D
71-501-01	1/4	0.43	1.12	2.25	7.00
71-502-01	3/8	0.50	1.12	2.25	7.00
71-503-01	1/2	0.50	1.12	2.25	7.00
71-504-01	3/4	0.68	1.50	3.00	7.00
71-505-01	1	0.87	1.68	3.37	7.00
71-506-01	1-1/4	1.00	2.00	4.00	9.00
71-507-01	1-1/2	1.25	2.18	4.37	9.00
71-508-01	2	1.50	2.34	4.68	9.00

73A-100 SERIES
FORGED CARBON STEEL BALL VALVE



BALL VALVES

Threaded, 2 piece design, 1/4" to 1" 2000 psig CWP, 1-1/4" to 2" 1500 psig CWP Cold Non-Shock. 150 psig Saturated Steam.

FEATURES

- RPTFE Seats & Packing
- Forged Construction
- Raised Handle Stops
- Blowout-Proof Stem Design
- Adjustable Packing Gland
- Zinc Phosphate Corrosion Protection
- (-24) Fire Safe to API 607 4th Edition, Class 600 Burn
- AAR Approval No. E119022
- Vacuum Service to 29 in. Hg

DIMENSIONS

MODEL NUMBER	SIZE (IN.)	DIMENSIONS (IN.)				
		A	B	C	D	E
73A-101-01A	1/4"	.37	1.02	2.30	1.72	3.85
73A-102-01A	3/8"	.37	1.08	2.37	1.72	3.85
73A-103-01A	1/2"	.50	1.18	2.31	1.78	3.85
73A-104-01A	3/4"	.68	1.57	3.07	2.07	4.75
73A-105-01A	1"	.87	1.73	3.40	2.18	4.75
73A-106-01	1-1/4"	1.00	1.98	3.97	2.72	5.50
73A-107-01	1-1/2"	1.25	2.14	4.32	3.12	7.75
73A-108-01	2"	1.50	2.73	5.44	3.27	7.75

76F-100-A SERIES
STAINLESS STEEL FULL PORT BALL VALVE

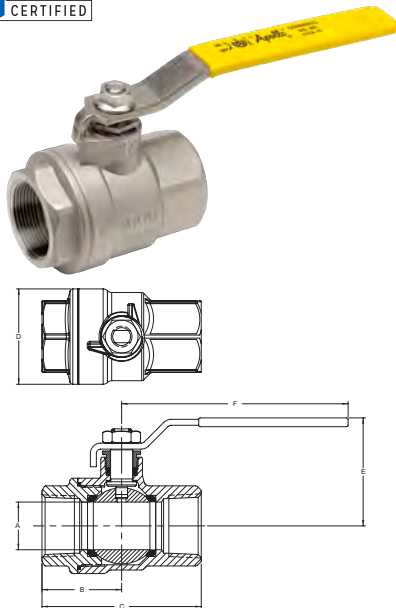

Threaded, 2 piece design, 1/4"-3" 1000 psig CWP Cold Non-Shock, 150 psig. Saturated Steam, Vacuum Service to 29 inches Hg.

FEATURES

- 316 SS Investment Cast Components
- RPTFE Seats
- Two-Piece Body
- Blowout-Proof Stem Design
- Adjustable Packing Gland
- Meets NACE MR-01-75-2000
- SS Lever and Nut
- (-11) Therma-Seal™ Insulating Tee
- (-24) Certified to API 607, 6th Ed., Class 600 Burn
- (-27) Locking Handle
- NSF/ANSI 61 Water Quality
- NSF/ANSI 372 Lead Free

DIMENSIONS

MODEL NUMBER	SIZE (IN.)	DIMENSIONS (IN.)						WT. (LB.)
		A	B	C	D	E	F	
76F-101-01	1/4"	0.37	0.95	1.91	1.12	1.60	3.85	0.47
76F-102-01	3/8"	0.37	0.95	1.91	1.12	1.60	3.85	0.44
76F-103-01A	1/2"	.50	1.21	2.35	1.27	1.73	3.85	0.57
76F-104-01A	3/4"	.75	1.39	2.77	1.62	1.96	3.85	0.91
76F-105-01A	1"	1.00	1.67	3.34	2.00	2.27	4.75	1.38
76F-106-01A	1-1/4"	1.25	1.96	3.92	2.73	3.21	7.77	4.17
76F-107-01A	1-1/2"	1.50	2.05	4.10	2.92	3.31	7.77	4.69
76F-108-01A	2"	2.00	2.37	4.74	3.75	3.69	7.77	6.90
76F-100-01A	3"	3.00	3.70	7.40	5.68	5.23	10.03	22.4



75-100-41 SERIES

PADLOCKING BALL VALVE WITH AUTOMATIC DRAIN

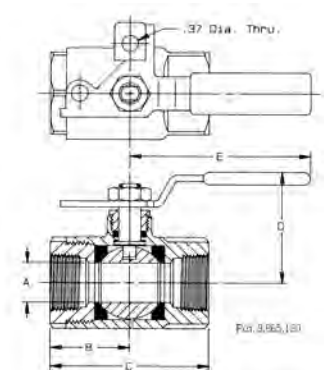

Meets OSHA standards and provides for easy, safe maintenance of pneumatic tools. Valve drains downstream pressure for safety when lever is closed. Valve can be padlocked OPEN or CLOSED with same hardware.

FEATURES

- Blowout-proof Stem Design
- Adjustable Packing Gland
- ASTM B584 Bronze
- RPTFE Seats and Stuffing Box Ring
- Pad Lock Lever
- Rated to 600 psi CWP - 150 SWP
- Temperature Range: 50°F to 200°F
- Valve Without Drain Option (suffix -01)

DIMENSIONS

MODEL NUMBER	SIZE (IN.)	DIMENSIONS (IN.)				
		A	B	C	D	E
75-101-41	1/4	0.43	1.12	2.25	1.81	3.00
75-102-41	3/8	0.50	1.12	2.25	1.81	3.00
75-103-41	1/2	0.50	1.12	2.25	1.81	3.00
75-104-41	3/4	0.87	1.68	3.37	2.25	3.87
75-105-41	1	0.87	1.68	3.37	2.25	3.87
75-106-41	1-1/4	1.00	2.00	4.00	2.62	5.50
75-107-41	1-1/2	1.25	2.16	4.37	2.87	5.50
75-108-41	2	1.50	2.34	4.68	3.06	5.50

77-100 SERIES

HEAVY DUTY FULL PORT NPT PANEL MOUNT BALL VALVE

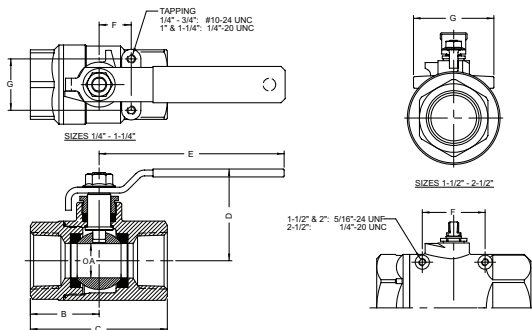
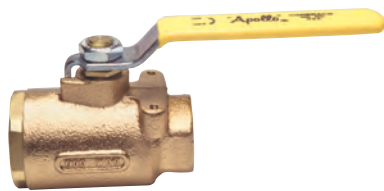

Designed for easy actuator mounting or panel mounting where highest C_v values are desired. RPTFE seats and stuffing box ring. Also available with 250 lb. steam trim option.

FEATURES

- Mounting Pad
- ASTM B584 Bronze
- Blowout-Proof Stem Design
- Adjustable Packing Gland
- Full Flow, Minimum Pressure Drop
- 600 CWP, Non-Shock Pressure Rating
- 150 SWP Steam Rating
- Chain Lever Kits Available 3/4"- 2-1/2" (-16, -58)

OPTIONS

- (-27) Locking Handle
- (-92) Balance Stop

DIMENSIONS

MODEL NUMBER	SIZE (IN.)	DIMENSIONS (IN.)							CV*
		A	B	C	D	E	F	G	
77-101-01	1/4	0.43	1.12	2.25	1.81	3.87	0.50	1.12	8.1
77-102-01	3/8	0.50	1.12	2.25	1.81	3.87	0.50	1.12	15
77-103-01	1/2	0.50	1.12	2.25	1.81	3.87	0.50	1.12	15
77-104-01	3/4	0.81	1.56	3.12	2.12	4.87	0.87	1.37	51
77-105-01	1	1.00	1.81	3.62	2.62	5.50	0.93	1.50	68
77-106-01	1-1/4	1.25	2.12	4.25	2.87	5.50	0.93	1.50	125
77-107-01	1-1/2	1.50	2.37	4.75	3.34	8.00	2.08	3.06	177
77-108-01	2	2.00	2.65	5.37	3.71	8.00	2.41	3.52	389
77-109-01	2-1/2	2.50	3.25	6.50	4.12	8.00	2.75	3.37	503

The Cv factor is the gallons of water per minute that the valve will pass with 1 psig pressure drop.

Actuation assistance available in Section D, with the Apollo® Actuator Wizard located at actuatorwizard.conbraco.com or by calling customer support at (704)841-6000.

BALL VALVES

77-200 SERIES
HEAVY DUTY FULL PORT SOLDER END BALL VALVE



Designed to be soldered into lines without disassembly. This allows a factory tested valve to be installed without disturbing the seats and seals. Designed for soft solder with melt points less than 500°F.

FEATURES

- Heavy Duty Cast Bronze Body
- Chromium Plated Ball
- Blowout-Proof Stem Design
- Adjustable Packing Gland
- Full Flow, Minimum Pressure Drop
- 600 CWP, Non-Shock Pressure Rating
- 150 SWP

DIMENSIONS

PART NUMBER	SIZE (IN.)	DIMENSIONS (IN.)						
		A	B	C	D	E	F	G
77-204-01	3/4	0.81	2.12	4.12	2.12	4.87	0.88	0.75
77-205-01	1	1.00	2.33	4.60	2.62	5.50	1.13	0.90
77-206-01	1-1/4	1.25	2.60	5.15	2.87	5.50	1.38	0.96
77-207-01	1-1/2	1.50	3.00	6.00	3.34	8.00	1.63	1.09
77-208-01	2	2.00	3.62	7.24	3.71	8.00	2.13	1.34
77-209-01	2-1/2	2.50	3.93	7.87	4.12	8.00	2.63	1.48

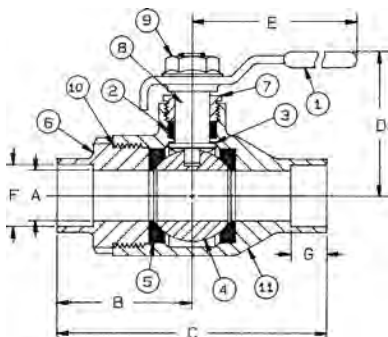

BALL VALVES

77-900 SERIES
FULL PORT SAE STRAIGHT-THREAD BALL VALVE



Valve connections are designed for extended leak-free and energy saving performance in a broad range of applications, especially in manufacturing environments.

FEATURES

- Mounting Pad for Easy Actuation
- 600 CWP Non-Shock
- 150 SWP
- ASTM B584 Bronze
- SAE J1926-1 (ISO 11926-1) Connections
- RPTFE Seats & Packing
- Blowout-Proof Stem and Lever Handle Standard
- Adjustable Packing Gland
- Full Port
- Straight Thread with O-Ring Boss Connection

DIMENSIONS

MODEL NUMBER	NOM. TUBE O.D. (IN.)	SIZE (IN.)	DIMENSIONS (IN.)						
			A	B	C	D	E	F	G
77-901-01	1/4	7/16-20	0.43	1.12	2.25	1.81	3.87	0.50	1.12
77-902-01	3/8	9/16-18	0.50	1.12	2.25	1.81	3.87	0.50	1.12
77-903-01	1/2	3/4-16	0.50	1.12	2.25	1.81	3.87	0.50	1.12
77-904-01	3/4	11/16-12	0.81	1.56	3.12	2.12	4.87	0.87	1.37
77-905-01	1	15/16-12	1.00	1.81	3.62	2.62	5.50	0.93	1.50
77-906-01	1-1/4	1-5/8-12	1.25	2.12	4.25	2.87	5.50	0.93	1.50
77-907-01	1-1/2	1-7/8-12	1.50	2.37	4.75	3.34	8.00	2.08	3.06
77-908-01	2	2-1/2-12	2.00	2.65	5.37	3.71	8.00	2.41	3.52

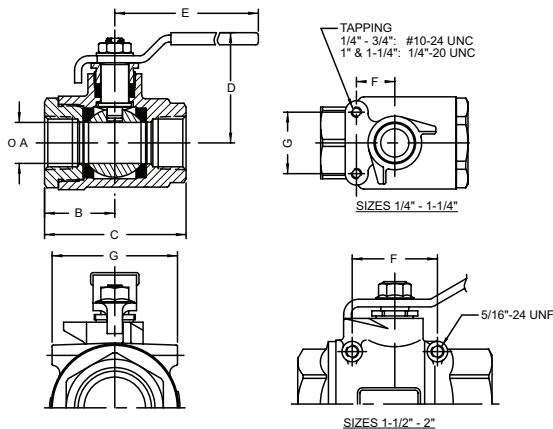

Actuation assistance available in Section D, with the Apollo® Actuator Wizard located at actuatorwizard.conbraco.com or by calling customer support at (704)841-6000.



77D SERIES

BRONZE BALL VALVE W/ DIRECT ISO MOUNTING PAD



Apollo's solid stainless steel ball design in a bronze valve with an integral ISO 5211 mounting pad with 100% American construction.

FEATURES

- 600 CWP Pressure Rating
- Multi-Fill Seats and Stem Bearing
- Blowout-Proof Stem Design
- Vacuum Service to 29 in. Hg
- High Cycle Dual O-Ring Stem Seal Design
- EPDM is Standard. Most Liquids and Gases are Compatible with the O-Ring Seals
- Ball is Slot Vented to Equalize Cavity and Line Pressure
- MSS SP-110 Compliant
- Direct Mount Actuator Ready

SEATS

SUFFIX	MATERIAL	TEMP RANGE	STEAM (MAX)
-01E (Standard)	EPDM	-20 to 400°F	150 SWP @ 366°F
-01N	Nitrile	-20 to 250°F	15 SWP @ 250°F
-01V	Viton	-20 to 400°F	50 SWP @ 297°F

DIMENSIONS

MODEL NUMBER	SIZE (IN.)	DIMENSIONS (IN.)									
		A	B	C	D	E	F	ØF1	G	ØG1	H
77D-143-01E	1/2	0.50	1.15	2.25	1.00	1.37	0.997	0.224	1.167	0.281	0.275
77D-144-01E	3/4	0.75	1.33	2.65	1.38	1.79	1.167	0.281	1.392	0.281	0.275
77D-145-01E	1	1.00	1.54	3.07	1.67	2.20	1.167	0.281	1.392	0.281	0.430
77D-147-01E	1-1/2	1.50	2.12	4.23	2.31	3.05	N/A	N/A	1.949	0.344	0.551
77D-148-01E	2	2.00	2.43	4.85	2.68	3.43	N/A	N/A	1.949	0.344	0.551

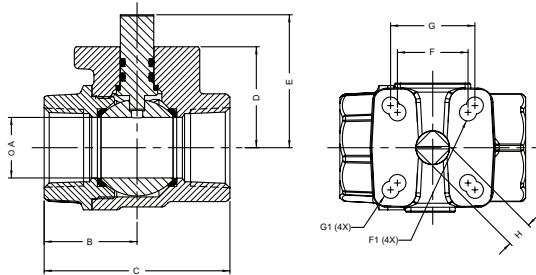

7K-100 SERIES

SAFETY EXHAUST VALVE W/ 1/4" NPT TAP FOR DRAIN



For use on pneumatic equipment. Furnished with a 1/4" NPT tapped drain to accommodate a muffler or to pipe the exhausted air to a safe location.

FEATURES

- Safely Vents Compressed Air (or Other Non-Hazardous Gases) From Piping Downstream of the Closed Valve
- Sizes 1/4" - 2-1/2"
- FNPT Threads
- Rated 125 psig-Air or Water, CWP, Non-Shock
- Temperature Range: +50°F to +200°F
- Optional Stainless Steel Latch Lock Handle that Locks in Closed Position Only, Specify Suffix (-46)

DIMENSIONS

MODEL NUMBER	SIZE (IN.)	DIMENSIONS (IN.)										
		A	B	C	D	E	F	G	H	I	J	K
7K-101-01	1/4	0.37	1.03	2.06	1.75	3.87	N/A	N/A	0.09	0.53	1.18	N/A
7K-102-01	3/8	0.37	1.03	2.06	1.75	3.87	N/A	N/A	0.09	0.53	1.18	N/A
7K-103-01	1/2	0.50	1.10	2.19	1.75	3.87	N/A	N/A	0.12	0.59	1.25	N/A
7K-104-01	3/4	0.81	1.56	3.12	2.12	4.78	0.87	1.37	0.29	0.90	1.56	0.90
7K-105-01	1	1.00	1.80	3.61	2.62	5.50	0.93	1.50	0.31	1.12	1.78	1.12
7K-106-01	1-1/4	1.25	2.12	4.25	2.87	5.50	0.93	1.50	0.37	1.37	2.03	1.37
7K-107-01	1-1/2	1.50	2.37	4.74	3.30	7.78	2.08	3.06	0.50	1.56	2.21	1.28
7K-108-01	2	2.00	2.70	5.38	3.71	7.78	2.41	3.52	0.62	2.03	2.68	1.56
7K-109-01	2-1/2	2.50	3.25	6.50	4.05	7.78	2.75	3.37	1.09	2.34	3.00	2.00

Also available in 70 & 77 Series as -41 option (without tapped drain)

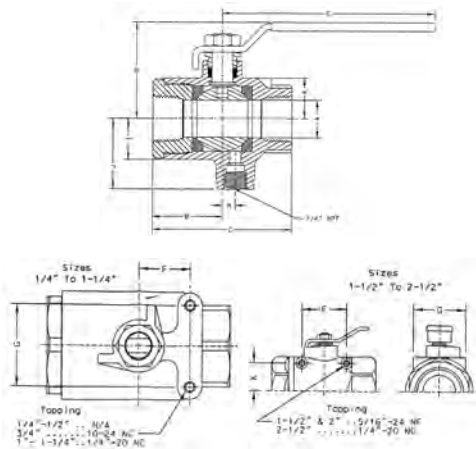

7K-SV SERIES
SECURE-VENT FEATURE (-SV)



(7K-SV SERIES SHOWN)

3/4" TO 1.25" SIZE
TAPPING:
3/4" (10-24 NC)
1" TO 1.25" (1/4"-20 NC)

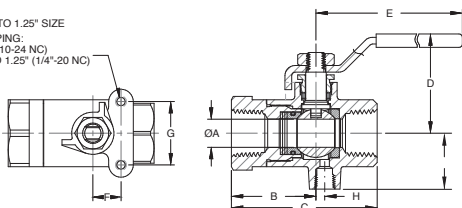

1.5" TO 2" SIZE
TAPPING:
1.50" TO 2" (5/16"-24 UNF)

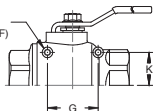

Available on the Apollo® 77 and 7K full port bronze ball valves. Safely vents compressed air (or other non-hazardous gases) from piping downstream of the closed valve.

FEATURES

- Reliable Shut-Off and Venting
- Pressure Rating: 200 psig CWP, Non-Shock
- Temperature Range: -20°F to 200°F
- Economical "No Leakage" Operation
- Belleville Spring Live-Loaded Active Upstream Seating
- Available with a Full Complement of Handles

DIMENSIONS

MODEL NUMBER	SIZE	DIMENSIONS (IN.)										WT. (LB.)
		A	B	C	D	E	F	G	H	J	K	
7K-103-SV	1/2"	0.50	1.50	2.59	1.76	3.88	0.50	1.12	0.12	1.25	-	0.73
7K-104-SV	3/4"	0.81	1.82	3.37	2.16	4.78	0.87	1.37	0.29	1.56	0.901	1.93
7K-105-SV	1"	1.00	2.05	3.86	2.69	5.43	0.93	1.50	0.31	1.78	1.121	3.42
7K-106-SV	1.25"	1.25	2.37	4.50	2.91	5.43	0.93	1.50	0.37	2.03	1.371	5.15
7K-107-SV	1.5"	1.50	2.63	5.00	3.31	7.78	1.04	3.06	0.50	2.21	1.282	6.81
7K-108-SV	2"	2.00	3.00	5.69	3.73	7.78	1.20	3.52	0.62	2.68	1.562	11.85

1 To Top of Mounting Pad
2 To Centerline of Mounting Pad

78-260/290 SERIES
INSTRUMENTATION BALL VALVES / TEST COCKS



78LF-290: BRONZE

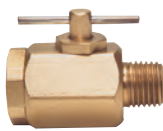

78-261: BRASS

Brass and bronze instrumentation ball valves and backflow test cocks. Male x female threaded. 400 psig CWP, non-shock. Air and liquid service.

FEATURES

- Micro-Finish Ball
- Blowout-Proof Stem Design
- PTFE Seats
- Nitrile Stem Seal
- Plated Steel Tee Handle
- Compact Design
- Optional Mixed End Fittings Available

BRASS INSTRUMENTATION BALL VALVE - TEE HANDLE

MODEL NUMBER	SIZE (IN.)	DIMENSIONS (IN.)					C _v *	WT. (LB.)
		A	B	C	D	E		
78-261-05	1/4M x 1/4F	0.31	0.43	1.43	0.87	1.25	5.50	0.19

BRONZE INSTRUMENTATION BALL VALVE (INTERNATIONAL) - SCREW SLOT - LEAD FREE

MODEL NUMBER	SIZE (IN.)	DIMENSIONS (IN.)					C _v *	WT. (LB.)
		A	B	C	D	E		
78LF-290-01	1/8M x 1/4F	0.21	0.80	1.60	0.72	N/A	4.00	0.19
78LF-291-01	1/4M x 1/4F	0.31	0.80	1.60	0.72	N/A	5.50	0.19
78LF-292-01	1/8 x 1/4 SAE	0.21	0.80	1.60	0.72	N/A	4.00	0.19
78LF-293-01	1/4 x 1/4 SAE	0.31	0.80	1.60	0.72	N/A	5.50	0.19

*The Cv factor is the gallons of water per minute that the valve will pass with a 1 psig pressure drop.
*Also see 94MBV Instrumentation Ball Valve

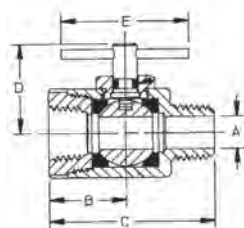

BRONZE VALVES - TEE

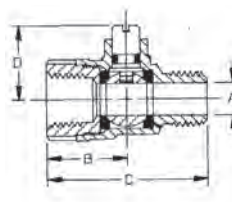

BRONZE VALVES - SLOT



78-130 SERIES

FEMALE END IRRIGATION VALVE (UNDERGROUND SERVICE)

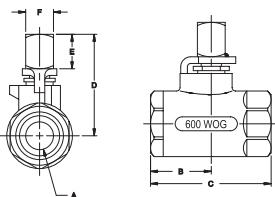

Ideal for underground or below grade applications. This series (3/8"-2" FNPT) features a square head nut welded to the stem to allow operations with a ground key from standard grade.

OPTIONS

- (-41) Auto-Drain (Directional)

DIMENSIONS

MODEL NUMBER	SIZE (IN.)	DIMENSIONS (IN.)					
		A	B	C	D	E	F
78-132-01	3/8	0.37	1.03	2.06	1.75	0.62	0.50
78-133-01	1/2	0.50	1.09	2.18	1.83	0.62	0.50
78-134-01	3/4	0.68	1.50	3.00	2.12	0.62	0.62
78-135-01	1	0.87	1.68	3.37	2.25	0.62	0.62
78-136-01	1-1/4	1.00	2.00	4.00	2.88	0.75	0.75
78-137-01	1-1/2	1.25	2.18	4.38	3.06	0.75	0.75
78-138-01	2	1.50	2.34	4.68	3.25	0.75	0.75

78-620 SERIES

BRONZE NPT IRRIGATION VALVE WITH AUTO-DRAIN

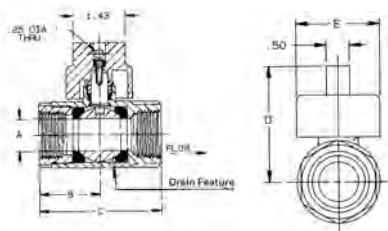

Ideal for underground use or where drained media will not cause damage. Heavy pattern design features ASTM B584 bronze body.

FEATURES

- Auto-Drain Feature (When Valve is in Closed Position) is Standard
- Adjustable Packing Gland
- RPTFE Seats and Seals
- Stainless Steel Cover
- 200 psig Water, CWP, Non-Shock
- Temperature Range +50°F to 200°F

DIMENSIONS

MODEL NUMBER	SIZE (IN.)	DIMENSIONS (IN.)				
		A	B	C	D	E
78-621-01	3/4	0.68	1.47	2.96	2.40	1.81
78-622-01	1	0.87	1.66	3.34	2.53	1.81
78-623-01	1-1/4	1.00	1.98	3.97	3.00	2.50
78-624-01	1-1/2	1.25	2.12	4.28	3.18	2.50
78-625-01	2	1.50	2.35	4.67	3.37	2.50

78-660 & 962 SERIES

BRONZE PURGE & DRAIN BALL VALVE (CENTER DRAIN)

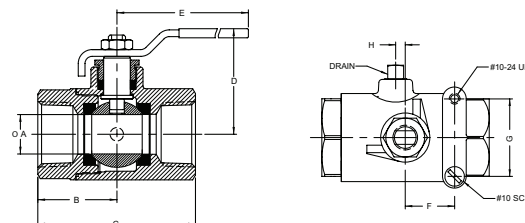

Center tap drain allows for winterization or purge and drain function. Features bronze body with built-in mounting pad for panel mounting or actuation. Ideal for hydronic heating and marine applications, downstream of the closed valve.

FEATURES

- 1/8" NPT Side Tap and Plug
- RPTFE Seats and Stuffing Box Ring
- Stainless Steel Lever and Nut
- Blowout-Proof Stem
- 600 psig CWP, Non-Shock
- Adjustable Packing
- Drainable Ball Cavity to Prevent Freezing

DIMENSIONS

MODEL NUMBER	SIZE (IN.)	DIMENSIONS (IN.)							
		A	B	C	D	E	F	G	H
78-664-01	3/4	0.68	1.50	3.00	2.12	4.87	0.87	1.37	0.17
78-665-01	1	0.87	1.68	3.37	2.25	4.87	0.87	1.37	0.21
78-667-01	1-1/2	1.25	2.18	4.37	3.05	8.00	0.93	1.50	0.40
78-962-01	2	1.50	2.34	4.68	3.24	8.00	0.93	1.50	0.45

Actuation assistance available in Section D, with the Apollo® Actuator Wizard located at actuatorwizard.conbraco.com or by calling customer support at (704)841-6000.

79-700 SERIES

UL LISTED REFRIGERANT BALL VALVE ASSEMBLY

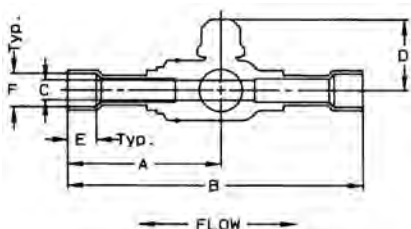

Complete hermetically welded assembly includes copper extensions and forged brass refrigerant ball valve with capped, triple-sealed stem to minimize leaks.

FEATURES

- Chrome Plated Ball
- RPTFE Seats and Seals
- Full Port Through 2-5/8"
- Bi-Directional Flow Design
- Sizes RANGE: 3/8" - 3-1/8" O.D. Tube
- All Sizes UL Listed - SFJQ
- Rated 500 psig CWP, Non-Shock
- For Use With Refrigerant Group 2 Fluids

DIMENSIONS

MODEL NUMBER	SIZE (IN.)	DIMENSIONS (IN.)						C _v *
		A	B	C	D	E	F	
79-701-01	3/8	3.38	6.45	0.45	1.56	0.38	0.38	8.5
79-702-01	1/2	3.38	6.45	0.45	1.56	0.38	0.50	8.5
79-703-01	5/8	3.56	6.82	0.50	1.56	0.50	0.62	9.8
79-704-01	7/8	3.91	7.53	0.68	1.79	0.75	0.87	32.0
79-705-01	1-1/8	4.39	8.51	0.87	1.98	0.90	1.12	44.0
79-706-01	1-3/8	4.42	8.94	1.25	2.62	0.96	1.38	66.0
79-707-01	1-5/8	4.55	9.19	1.25	2.62	1.09	1.62	148.0
79-708-01	2-1/8	5.16	10.31	1.50	2.93	1.34	2.12	218.0
79-709-01	2-5/8	6.50	13.00	2.50	3.90	1.48	2.62	440.0
79-600-01	3-1/8	7.00	14.00	2.50	3.90	1.67	3.12	390.0

*The Cv factor is the gallons of water per minute that the valve will pass with 1 psig pressure drop.

9A-100 SERIES

HEAVY PATTERN UNIBODY THREADED BALL VALVE

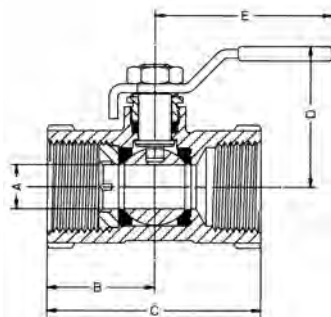

One piece bronze valve eliminates leak paths. Features static grounding devices and adjustable packing gland. Lever handle standard.

FEATURES

- Rated 600 psig CWP, Non-Shock
- 50 SWP
- Blowout-Proof Stem Design

OPTIONS

- (-30) Cam Lock
- (-15) Round Handle
- (-27) Latch Lock Handle

DIMENSIONS

MODEL NUMBER	SIZE (IN.)	DIMENSIONS (IN.)				
		A	B	C	D	E
9A-101-01	1/4	0.37	1.34	2.59	1.68	3.87
9A-102-01	3/8	0.37	1.34	2.59	1.68	3.87
9A-103-01	1/2	0.37	1.34	2.59	1.81	3.87
9A-104-01	3/4	0.50	1.44	2.84	1.84	3.87
9A-105-01	1	0.62	1.72	3.28	2.00	4.87
9A-106-01	1-1/4	0.81	1.94	3.84	2.18	4.87
9A-107-01	1-1/2	1.00	2.06	4.00	2.68	5.50
9A-108-01	2	1.25	2.29	4.56	2.87	5.50



82-100 SERIES
FULL PORT BRONZE THREE-PIECE VALVE

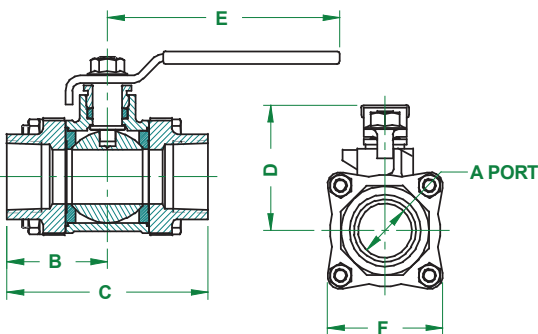
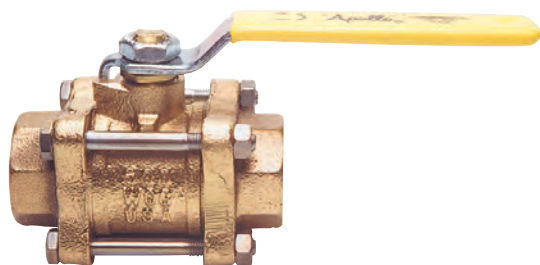

This inline-repairable threaded ball valve offers RPTFE seats and seals and a 600 CWP, non-shock rating.

FEATURES

- ASTM B584 Bronze Body and Ends
- SAE Grade 8 Body Bolts
- Adjustable Packing Nut
- Full Port Flow
- 600 CWP, 150 SWP (3"-4" 400 CWP, 150 SWP)
- EZ-Solder™ Lead Free Bronze
- Numerous Options Available
- 82-14x/24x w/ SS Ball and Stem Option
- Lead Free Option (82LF) is NSF/ANSI 61 and NSF/ANSI 372 Lead Free Certified
- Easily Identifiable White Handle Grip and Blue "Lead Free" Hang Tag

DIMENSIONS

MODEL NUMBER	LF MODEL NUMBER	SIZE (IN.)	DIMENSIONS (IN.)						WT. (LB.)
			A	B	C	D	E	F	
NPT									
82-101-01	82LF-101-01	1/4"	0.43	1.28	2.56	1.81	3.87	1.60	1.02
82-102-01	82LF-102-01	3/8"	0.50	1.28	2.56	1.81	3.87	1.60	1.04
82-103-01	82LF-103-01	1/2"	0.62	1.40	2.81	1.93	4.87	1.78	1.55
82-104-01	82LF-104-01	3/4"	0.81	1.71	3.43	2.18	4.87	1.98	2.27
82-105-01	82LF-105-01	1"	1.00	1.93	3.87	2.62	5.50	2.22	3.28
82-106-01	82LF-106-01	1.25"	1.25	2.37	4.75	2.87	5.50	2.70	5.62
82-107-01	82LF-107-01	1.5"	1.50	2.62	5.25	3.37	8.00	3.03	8.07
82-108-01	82LF-108-01	2"	2.00	3.01	6.03	3.68	8.00	3.87	14.42
82-109-01	82LF-109-01	2.5"	2.50	3.62	7.25	5.14	9.75	5.05	26.61
82A-140-01	-	3"	3.00	4.18	8.37	8.10	19.13	5.82	43.00
82A-14A-01	-	4"	4.00	5.43	10.86	8.88	19.13	7.77	106.00

*3" & 4" valves come standard with SS ball and stem (not optional) and adjustable length locking handles.

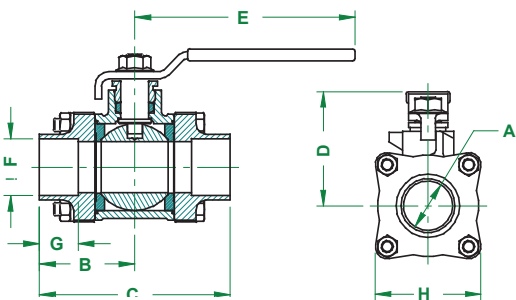
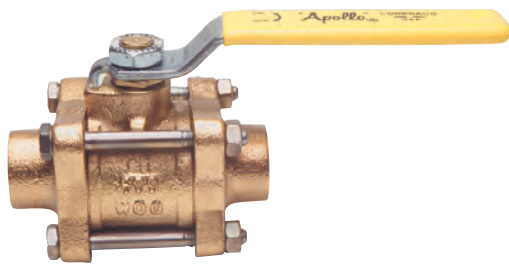

Designed for soft soldering or brazed* installation. Includes RPTFE seats and seals.

DIMENSIONS

MODEL NUMBER	LF MODEL NUMBER	SIZE (IN.)	DIMENSIONS (IN.)							
			A	B	C	D	E	F	G	H
SOLDER										
82-202-01	82LF-202-01	3/8	0.44	1.28	2.56	1.81	3.87	0.50	0.38	1.60
82-203-01	82LF-203-01	1/2	0.56	1.40	2.81	1.93	4.87	0.63	0.50	1.78
82-204-01	82LF-204-01	3/4	0.83	1.71	3.43	2.18	4.87	0.88	0.75	1.98
82-205-01	82LF-205-01	1	1.00	1.93	3.87	2.62	5.50	1.13	0.90	2.22
82-206-01	82LF-206-01	1-1/4	1.25	2.37	4.75	2.87	5.50	1.38	0.97	2.70
82-207-01	82LF-207-01	1-1/2	1.50	2.62	5.25	3.37	8.00	1.63	1.09	3.03
82-208-01	82LF-208-01	2	2.00	3.01	6.03	3.68	8.00	2.13	1.34	3.87
82-209-01	82LF-209-01	2-1/2	2.50	3.62	7.25	5.14	9.75	2.63	1.47	5.05
82A-240-01	-	3	3.00	4.18	8.37	8.10	19.13	3.13	1.66	5.82
82A-24A-01	-	4	4.00	5.43	10.86	8.88	19.13	4.13	2.16	7.77

*3" & 4" valves come standard with SS ball and stem (not optional) and adjustable length locking handles.

*82LF-2xxA cannot be brazed and is intended for soft solder installation using solders with melting temperature of < 500°F.

BALL VALVES

82-200/82-240 SERIES

THREE-PIECE FULL PORT VALVE WITH BRAZED TUBE EXTENSIONS

"F1 - 1 GAUGE PORT", "F3 - 2 GAUGE PORTS", & "NO GAUGE PORT" CONFIGURATIONS

- Bronze Valve Body & End Caps
- RPTFE Seats and Stem Packing
- 600 psig CWP Non-Shock (3" & 4" 400 CWP)
- Vacuum Service to 29" Hg
- Full Port in All Sizes
- Blowout-Proof Stem Design
- Adjustable Packing Nut
- In-Line Repairable
- Latch Lock Handle
- Cleaned and Bagged for Oxygen
- Service per CGA G4.1 & NFPA 99
- Factory Brazed Extensions Allow Solder or Brazed Installation Without Disassembly
- Type K Copper Tubing Brazed Into Both End Caps
- **Made in USA**

OUTSIDE THE ZONE BOX

NFPA 99 requires the valves to be secured in the open position. For medical gas applications that are Outside-the-Zone-Box, Apollo® offers three standard configurations: "F1" (1 gauge port), "F3" (2 gauge ports) & no gauge ports (w/ locking handles).

82-200-F1/82-240-F1 SERIES

MALE EXTENSIONS - 1 GAUGE PORT

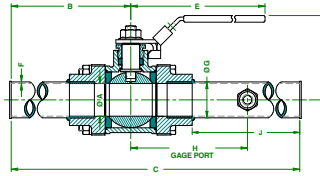

DIMENSIONS

OXYGEN CLEANED					SIZE (IN.)	DIMENSIONS (IN.)										WT. (LB.)
TRIM PLATED PART NUMBER	316SS BALL & STEM PART NUMBER	TRIM PLATED PART NUMBER	316SS BALL & STEM PART NUMBER	316SS BALL, STEM & EXT. TRIM PART NUMBER		A	B	C	D	LOCKING	NON LOCKING	F	G	H	J	
W/ LOCKING HANDLE		W/ NON LOCKING HANDLE								E	E					
82-203-F1	82-243-F1	82-203-F2	82-243-F2	82-243-E9	1/2"	0.62	6.91	17.41	2.23	5.31	4.75	0.049	0.625	7.15	9.10	1.7
82-204-F1	82-244-F1	82-204-F2	82-244-F2	82-244-E9	3/4"	0.81	6.97	17.47	2.41	5.31	4.75	0.065	0.75	7.22	8.78	2.4
82-205-F1	82-245-F1	82-205-F2	82-245-F2	82-245-E9	1"	1.00	7.03	17.62	3.01	6.29	5.56	0.065	1.25	7.28	5.09	3.4
82-206-F1	82-246-F1	82-206-F2	82-246-F2	82-246-E9	1-1/4"	1.25	7.38	22.71	3.22	6.29	5.56	0.065	1.375	7.00	12.97	5.5
82-207-F1	82-247-F1	82-207-F2	82-247-F2	82-247-E9	1-1/2"	1.50	7.50	22.57	4.04	8.93	7.75	0.072	1.625	6.74	12.48	8.5
82-208-F1	82-248-F1	82-208-F2	82-248-F2	82-248-E9	2"	2.00	7.74	22.58	4.15	8.93	7.75	0.083	2.125	6.51	11.76	14.0
82-209-F1	82-249-F1	82-209-F2	82-249-F2	82-249-E9	2-1/2"	2.50	11.75	23.50	5.31	10.06	9.92	0.095	2.50	6.38	8.13	26.8
-	82A-240-F1	-	-	82A-240-E9	3"	3.00	11.94	23.87	8.10	18.00*	18.00*	0.0450	3.00	7.75	7.76	42.2
-	82A-24A-F1	-	-	82A-24A-E9	4"	4.00	12.68	25.37	8.88	18.00*	18.00*	0.0700	4.00	8.00	7.25	106.0

*3" & 4" valves come standard with SS ball and stem (not optional) and adjustable length locking handles.

82-200-F3/82-240-F3 SERIES

MALE EXTENSIONS - 2 GAUGE PORTS

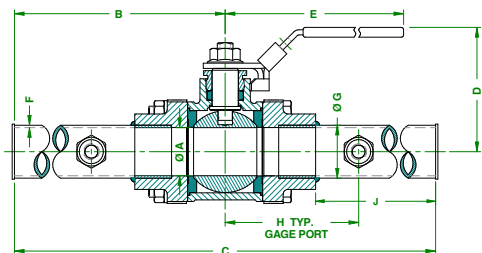

DIMENSIONS

OXYGEN CLEANED W/ LOCKING HANDLE		SIZE (IN.)	DIMENSIONS (IN.)										WT. (LB.)
TRIM PLATED PART NUMBER	316SS BALL & STEM PART NUMBER		A	B	C	D	LOCKING	F	G	H	J		
							E						
82-203-F3	82-243-F3	1/2"	0.62	12.27	24.53	2.23	5.31	0.049	0.625	4.25	10.84	1.66	
82-204-F3	82-244-F3	3/4"	0.81	12.25	24.50	2.41	5.31	0.065	0.75	4.24	10.53	2.37	
82-205-F3	82-245-F3	1"	1.00	12.30	24.60	3.01	6.29	0.065	1.25	4.24	10.32	3.43	
82-206-F3	82-246-F3	1-1/4"	1.25	12.23	24.46	3.22	6.29	0.065	1.375	4.23	9.89	5.50	
82-207-F3	82-247-F3	1-1/2"	1.50	12.25	24.50	4.04	8.93	0.072	1.625	4.25	9.63	8.51	
82-208-F3	82-248-F3	2"	2.00	12.25	24.50	4.15	8.93	0.083	2.125	4.25	9.18	14.0	
82-209-F3	82-249-F3	2-1/2"	2.50	11.75	23.50	5.31	10.06	0.095	2.50	6.38	8.13	26.81	
-	82A-240-F3	3"	3.00	11.94	23.87	8.10	18*	.0450	3.00	7.75	7.78	42.24	
-	82A-24A-F3	4"	4.00	12.68	25.37	8.88	18*	.0700	4.00	8.00	7.25	106.0	

*3" & 4" valves come standard with SS ball and stem (not optional) and adjustable length locking handles.

82-200/82-240 SERIES
MALE EXTENSIONS - NO GAUGE PORTS

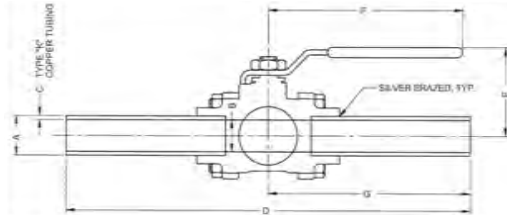

DIMENSIONS

STANDARD		OXYGEN CLEANED					SIZE (IN.)	DIMENSIONS (IN.)								WT. (LB.)	
TRIM PLATED PART NUMBER	316SS BALL & STEM PART NUMBER	TRIM PLATED PART NUMBER	316SS BALL & STEM PART NUMBER	316SS BALL, STEM & EXT. TRIM PART NUMBER	TRIM PLATED PART NUMBER	316SS BALL & STEM PART NUMBER		A	B	C	D	E	LOCKING F	NON LOCKING F	G		H
W/ NON LOCKING HANDLE		W/ NON LOCKING HANDLE			W/ LOCKING HANDLE												
82-203-B8	82-243-A8	82-203-K1	82-243-K1	82-243-C4	82-203-G3	82-243-G3	1/2"	5/8	0.62	0.049	13.81	2.00	4.87	5.28	6.00	5.50	1.7
82-204-A8	82-244-B3	82-204-K1	82-244-K1	82-244-C6	82-204-G3	82-244-G3	3/4"	7/8	0.81	0.065	13.93	2.18	4.87	5.28	6.00	5.25	2.4
82-205-B7	82-245-B1	82-205-K1	82-245-K1	82-245-E3	82-205-G3	82-245-G3	1"	1-1/8	1.00	0.065	14.04	2.62	5.50	6.25	6.00	5.09	3.4
82-206-B7	82-246-B0	82-206-K1	82-246-K1	82-246-C0	82-206-G3	82-246-G3	1-1/4"	1-3/8	1.25	0.065	14.75	2.89	5.50	6.25	6.00	5.03	5.5
82-207-B2	82-247-B2	82-207-K1	82-247-K1	82-247-C6	82-207-G3	82-247-G3	1-1/2"	1-5/8	1.50	0.072	15.07	3.37	8.00	8.92	6.00	4.91	8.5
82-208-B7	82-248-B2	82-208-K1	82-248-K1	82-248-C4	82-208-G3	82-248-G3	2"	2-1/8	2.00	0.083	15.23	3.70	8.00	8.92	6.00	4.66	14.2
82-209-A2	82-249-A2	82-209-K1	82-249-K1	-	82-209-G3	82-249-G3	2-1/2"	2-5/8	2.50	0.095	23.51	5.14	9.38	10.06	9.60	8.13	26.8
-	82A-240-A2	-	82A-240-K1	-	-	-	3"	3-1/8	3.00	0.109	24.00	6.77	18.00*	18.00*	9.40	7.76	42.24
-	82A-24A-A0	-	82A-24A-K1	-	-	-	4"	4-1/8	4.00	0.134	25.50	8.26	18.00*	18.00*	9.41	7.25	106.0

*3" & 4" valves come standard with SS ball and stem (not optional) and adjustable length locking handles.

82-200/82-240 SERIES
FEMALE EXTENSIONS - NO GAUGE PORTS

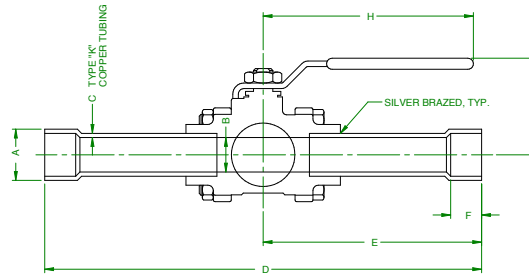

DIMENSIONS

STANDARD		OXYGEN CLEANED					SIZE (IN.)	DIMENSIONS (IN.)										WT. (LB.)
TRIM PLATED PART NUMBER	316SS BALL & STEM PART NUMBER	TRIM PLATED PART NUMBER	316SS BALL & STEM PART NUMBER	TRIM PLATED PART NUMBER	316SS BALL & STEM PART NUMBER	TRIM PLATED PART NUMBER		316SS BALL & STEM PART NUMBER	A	B	C	D	E	F	G	LOCKING H	NON LOCKING H	
W/ NON LOCKING HANDLE		W/ LOCKING HANDLE			W/ NON LOCKING HANDLE		W/ LOCKING HANDLE											
82-203-C2	82-243-B8	-	-	82-203-K2	82-243-K2	82-203-E0	82-243-E0	1/2"	5/8"	0.62	0.049	14.80	7.40	0.50	2.00	4.87	5.28	1.7
82-204-C3	82-244-C1	82-204-F0	-	82-204-K2	82-244-K2	82-204-E0	82-244-C9	3/4"	7/8"	0.81	0.065	15.42	7.71	0.75	2.18	4.87	5.28	2.4
82-205-C2	82-245-C1	82-205-G4	-	82-205-K2	82-245-K2	82-205-E4	82-245-E0	1"	1-1/8"	1.00	0.065	15.84	7.92	0.90	2.62	5.50	6.25	3.5
82-206-C1	82-246-C1	-	-	82-206-K2	82-246-K2	82-206-C7	82-246-C2	1-1/4"	1-3/8"	1.25	0.065	16.69	8.34	0.96	2.87	5.50	6.25	5.6
82-207-B8	82-247-C5	82-207-E9	-	82-207-K2	82-247-K2	82-207-C5	82-247-E3	1-1/2"	1-5/8"	1.50	0.072	16.16	8.58	1.09	3.37	8.00	8.92	8.6
82-208-C1	82-248-C0	82-208-E4	-	82-208-K2	82-248-K2	82-208-C8	82-248-C7	2"	2-1/8"	2.00	0.083	18.12	9.06	1.34	3.70	8.00	8.92	14.3
-	-	-	-	82-209-K2	82-249-K2	82-209-A8	82-249-A8	2-1/2"	2-5/8"	2.50	0.095	23.50	9.62	1.47	5.14	9.38	10.06	26.8
-	-	-	-	-	-	-	82A-240-K2	3"	3-1/8"	3.00	0.109	23.87	10.25	1.66	6.77	18.00*	18.00*	42.25

*3" valves are equipped with adjustable length locking handles.

6PLF SERIES

CAST IRON CLASS 125 FLANGED BALL VALVE - LEAD FREE

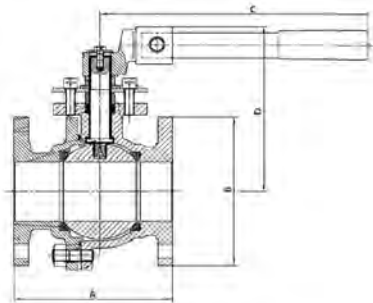

The cast iron/epoxy coated, Class 125 Apollo International™ 6PLF series lead free ball valves offer unobstructed turbulence-free flow that gate and butterfly valves can't match. Compact design and low profile handle for easy installation in tight areas. Ideal for both potable water and general HVAC applications.

FEATURES

- A126 Class B Cast Iron Body with FDA Food-Grade Epoxy Powder Coat
- Stainless Steel Ball & Stem
- PTFE Seats
- 200 CWP / 125 SWP
- ISO 5211 Mounting Pad for Easy Actuation
- Adjustable Stem Packing
- Full Port Through 6"
- Vacuum Service to 29in Hg
- Lever Handles 2-6"; Gear Operators 8-10"
- NSF/ANSI 61 Water Quality
- NSF/ANSI 372 Lead Free
- ANSI B16.10 Face-to-Face Dimensions Allow Direct Replacement of Comparable Gate Valves

DIMENSIONS

LF MODEL NUMBER	SIZE (IN.)	DIMENSIONS (IN.)				WT. (LB.)	ACTUATION KIT	DESCRIPTION
		A	B	C	D			
6PLF-208-01	2	7.00	6.00	12.20	6.50	22.70	78253001	KIT, MTG, 6PLF208 TO A0150
6PLF-209-01	2-1/2	7.50	7.00	13.78	7.42	36.73	78253101	KIT, MTG, 6PLF209 TO A0150
6PLF-200-01	3	8.00	7.50	13.78	8.17	46.63	78253201	KIT, MTG, 6PLF200 TO A0150
6PLF-20A-01	4	9.00	9.00	15.75	9.00	71.83	78253301	KIT, MTG, 6PLF20A TO A0350/0600
6PLF-20C-01	6	10.50	11.00	30.00	11.32	111.99	78253401	KIT, MTG, 6PLF20C TO A0950
6PLF-20E-01*	8	11.50	13.50	30.00	11.32	210.54	78253501	KIT, MTG, 6PLF20E/20G TO A01600/A2500
6PLF-20G-01*	10	13.00	16.00	33.00	13.05	294.10	78253501	KIT, MTG, 6PLF20E/20G TO A01600/A2500

*Gear operator is standard

94 MBV SERIES

MINI BALL VALVE GAS RATED - APOLLO INTERNATIONAL™



M X F

F X F

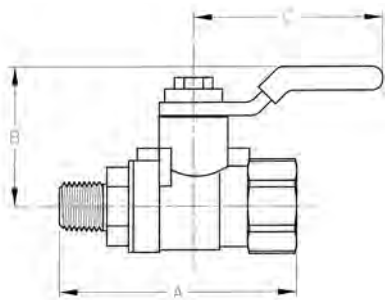

Designed for commercial and light industrial use. Full port, constructed of heavy-duty forged brass, PTFE seats and gland follower with double Viton o-rings to prevent stem leakage.

FEATURES

- Reversible Handle
- Blowout-Proof Stem
- Double Viton O-Ring Stem Seals
- Large Raised Wrench Flats
- Chrome Plated Brass Ball
- Ideal for Use as a Gas or Gauge Cock
- Maximum 600 psig at 100°F, Non-Shock
- Temperature Range: -40°F to 300°F
- ANSI Z21.15-2009 / CSA 9.1-2009 (1/2 psi) - Manually Operated Gas Valves for Appliances
- ASME B16.44-2002 - Manually Operated Metallic Gas Valves for Use in Above Ground Piping Systems (2 and 5 psig)
- MSS SP-110 Compliant

DIMENSIONS

MODEL NUMBER	SIZE (IN.)	DIMENSIONS (IN.)			PORT (DIA.)	WT. (LB.)
		A	B	C		
94-MBV-02	1/4 FNPT x 1/4 MNPT	1.95	1.09	1.71	0.31	0.20
94-MBV-03	1/4 FNPT x 1/4 FNPT	1.68	1.09	1.71	0.31	0.17
94-MBV-04	1/8 FNPT x 1/8 MNPT	1.95	1.09	1.71	0.31	0.16
94-MBV-05	1/8 FNPT x 1/8 FNPT	1.68	1.09	1.71	0.31	0.16



80-100 SERIES

UL LISTED GAS BRONZE SHUT-OFF VALVE

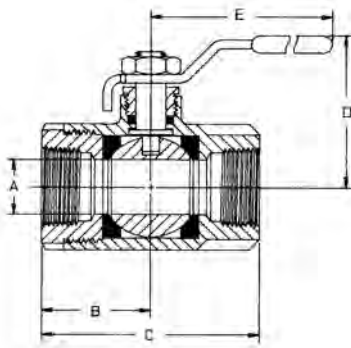
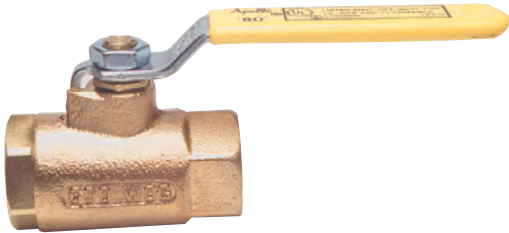

UL listed, heavy pattern, bronze shut-off valve for LP gas, natural gas, flammable liquids and heated oil. Features easy quarter-turn ON/OFF, a large port to reduce pressure drop and NPT connections.

FEATURES

- RPTFE Seats and Seals
- Rated 600 psig CWP, Non-Shock
- 250 psig LP Gas
- (-07) Tee Handle
- (-27) Latch Lock Handle
- (-57) Oxygen Cleaned

UL LISTED

- YQNZ - UL1477
- YRBX - UL842
- YRPV - UL842
- YSDT - UL125
- MHKZ - UL842

DIMENSIONS

MODEL NUMBER	SIZE (IN.)	DIMENSIONS (IN.)				
		A	B	C	D	E
80-101-01	1/4	0.37	1.03	2.06	1.75	3.87
80-102-01	3/8	0.37	1.03	2.06	1.75	3.87
80-103-01	1/2	0.50	1.12	2.25	1.81	3.87
80-104-01	3/4	0.68	1.50	3.00	2.12	4.87
80-105-01	1	0.87	1.68	3.37	2.25	4.87
80-106-01	1-1/4	1.00	2.00	4.00	2.62	5.50
80-107-01	1-1/2	1.25	2.18	4.37	2.87	5.50
80-108-01	2	1.50	2.34	4.68	3.06	5.50
80-109-01	2-1/2	2.50	3.25	6.50	4.12	8.00
80-100-01	3	2.50	3.37	6.75	4.12	8.00

BALL VALVES

90-100 SERIES

UL LISTED UNIBODY BRONZE THREADED BALL VALVE

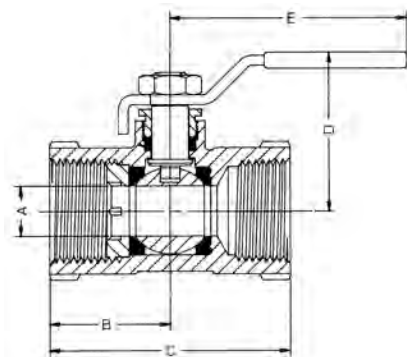

A compact 400 psig CWP valve that's UL listed for fuel, inert gases and flammable liquids. Features ASTM Grade Bronze body, RPTFE seats and seals.

FEATURES

- Blowout-Proof Stem Design
- One Piece Bronze Body
- Reduced Port

OPTIONS

- 90-14x with 316 SS Ball & Stem
- (-02) Static Grounded
- (-04) 2-1/4" Stem Extension
- (-05) Plain Ball
- (-07) Steel Tee Handle
- (-15) Steel Wheel Handle
- (-27) Latch Lock Handle
- (-57) Oxygen Cleaned

UL LISTED

- YQNZ - UL1477
- YRBX - UL842
- YRPV - UL842

DIMENSIONS

MODEL NUMBER	SIZE (IN.)	DIMENSIONS (IN.)				
		A	B	C	D	E
90-103-01A	1/2	0.37	1.14	2.15	1.68	3.87
90-104-01A	3/4	0.50	1.36	2.61	1.75	3.87
90-105-01A	1	0.62	1.50	2.90	2.00	4.87
90-106-01A	1-1/4	0.81	1.81	3.50	2.18	4.87
90-107-01A	1-1/2	1.00	2.06	3.79	2.62	5.50
90-108-01A	2	1.25	2.43	4.42	2.81	5.50

77G-UL SERIES
FULL PORT CSA/UL BRONZE GAS SHUT-OFF VALVE



UL and CSA listed fuel shut off valve that features a durable bronze body, premium "multi-fill" MPTFE seats and stem packing, and a "Solid Ball" design that delivers true full port flow performance.

FEATURES

- Blowout-Proof Stem Design
- ASTM B584 Bronze
- Maximum Body Pressure: 600 psig CWP
- CSA Rating: 125 psig
- CSA Rating: -20°F to 150°F
- UL Rating: 250 psig max @ 125°F
- MSS SP-110 Ball Valves
- CSA to ASME B16.33, 125
- CGA 3.16-M88, 125

UL LISTED

- YSDT
- YQNZ
- YRBX
- YRPV
- YRPV7
- YRBX7
- MHKZ7
- YSDT7

DIMENSIONS

MODEL NUMBER	SIZE (IN.)	DIMENSIONS (IN.)					WT. (LB.)
		A	B	C	D	E	
77G-103-UL	1/2	0.50	1.19	2.35	1.80	3.74	0.68
77G-104-UL	3/4	0.75	1.42	2.74	1.98	4.78	1.26
77G-105-UL	1	1.00	1.64	3.18	2.18	4.78	2.08

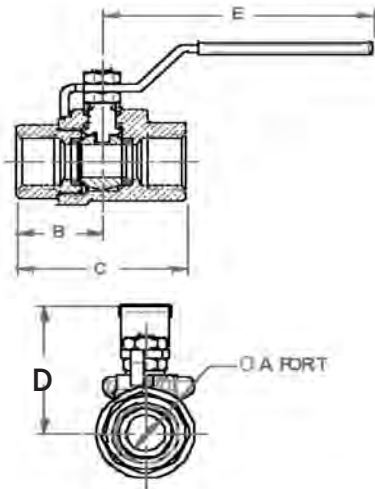

BALL VALVES



GB-10 SERIES

CSA GAS SHUT-OFF VALVE - CAST BRONZE



Manual shut-off valves engineered specifically for low pressure gas service. CSA design and capacity certified with American-made quality. High-copper content body, chrome-plated ball, and PTFE seats.

FEATURES

- Complies with ANSI Z21.15, CR91-002, and ASME 16.44
- Use with Natural, Manufactured, Mixed and Liquefied Petroleum Gases, LP Gas-Air Mixtures

- Temperature Range: 32°F to 125°F at Pressures of 1/2 and 5 psig
- (-01) Standard Die-Cast Zinc "Wing" Handle Epoxy Coated
- (-L1) Lever Handle or (-T1) Tee Handle Options
- **Proudly Made in USA**

DIMENSIONS

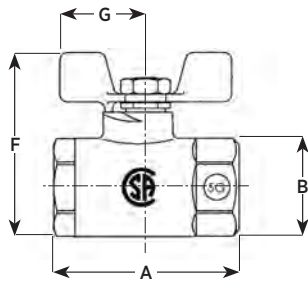

STANDARD - YELLOW DIE-CAST ZINC "WING HANDLE"

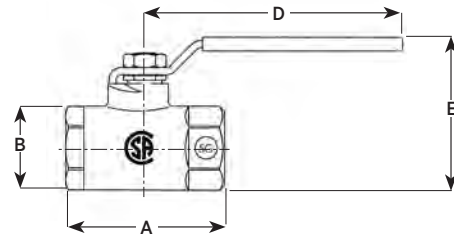

OPTIONAL - STAINLESS STEEL "LEVER HANDLE"

MODEL NUMBER	SIZE (IN.)	CONNECTION	BTU/HR*	DIMENSIONS (IN.)						
				A	B	C	D	E	F	G
51GB-201	3/8	3/8 NPT	318,700	2.04	1.06	0.38	3.85	2.24	2.20	0.81
51GB-301	1/2	1/2 NPT	623,750	2.24	1.18	0.50	3.85	2.30	2.24	0.81
51GB-401	3/4	3/4 NPT	1,265,000	2.97	1.55	0.69	4.75	2.85	2.90	1.00
51GB-501	1	1 NPT	2,037,500	3.33	1.81	0.88	4.75	3.10	3.15	1.00

*Capacity based on a gas having a heating value of 1000 BTU/cubic feet and an S.G. of 0.64 at a P.D. of 1" W.C.

GB-15 SERIES

GAS APPLIANCE BALL VALVE



Designed for natural gas, manufactured and mixed gas, liquefied petroleum gases and LP gas-air mixture applications. Apollo International™

FEATURES

- ANSI Z21.15 (Appliance & Hose)/CGA9.1(1/2 psi)
- ASME B16.44 (5 psi)
- UL Guide YRBX (Flammable Liquid Shut-Off)

- UL Guide MHKZ (Manual Valves)
- UL Guide YRPV (Gas Shut-Off -250#)
- UL Guide YSDT (LP Gas)

DIMENSIONS

MODEL NUMBER	PART NUMBER	SIZE & END CONNECTION (IN.)
GB-15	51GF301A	1/2 FNPT x 1/2 FNPT
GB-15	51GF401A	3/4 FNPT x 3/4 FNPT

GB-50/GB-50A SERIES
CSA GAS SHUT-OFF VALVE



Designed for "main burner" applications with cast-in single or dual pilot tap. ASTM B584 bronze body, chrome-plated ball, brass stem, retainer and gland screws for corrosion resistance. Single or double side taps for pilot light or pressure gauge connections.

FEATURES

- For Natural Gas, Manufactured and Mixed Gas, Liquefied Petroleum Gases and LP Gas-Air Mixtures
- Rated Pressures of 1/2 and 5 psig
- Standard Connection is FNPT x FNPT
- High BTU Capacity
- Reversible Plated Steel Lever Handle
- (-07) Tee Handle Optional

APPROVALS

- ANSI Z21.15, CGA9.1
- ASME B16.44 (2 and 5 psig)
- MSS SP-110
- UL Guide YRBX
- UL Guide MHKZ
- UL Guide YRPV
- UL Guide YSDT
- UL 125, UL 842

BALL VALVES



GB-50



GB-50A

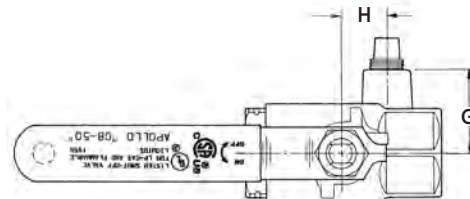
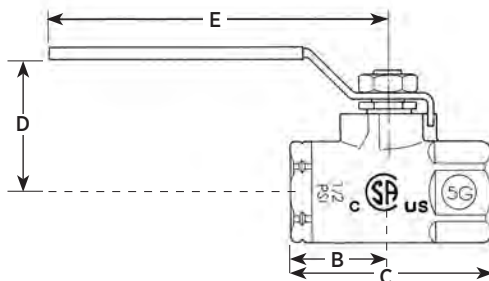
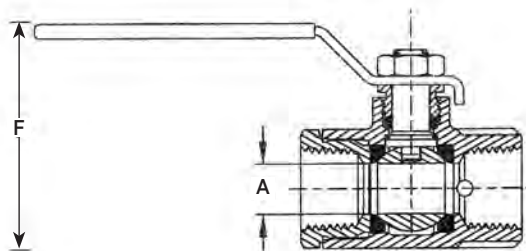
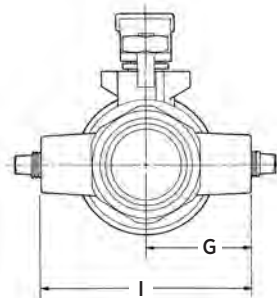

DIMENSIONS

MODEL NO. SINGLE TAPPED	MODEL NO. DUAL TAPPED	SIZE (IN.)	TAPPING	DIMENSIONS (IN.)									CAPACITY BTU/HR.
				A	B	C	D	E	F	G	H	I	
50GB-301	--	1/2	1/8	0.50	1.11	2.25	1.68	3.85	2.27	1.00	0.53	-	693,000
50GB-401	50GB-401A	3/4	1/8	0.75	1.26	2.67	1.93	3.85	2.72	1.12	0.75	2.24	1,258,000
50GB-501	50GB-501A	1	1/8	1.00	1.65	3.42	2.19	4.78	3.18	1.53	0.94	3.06	3,144,000
50GB-601	50GB-601A	1-1/4	1/8	1.25	1.87	3.86	2.37	4.78	3.56	1.62	1.15	3.24	6,441,000
50GB-701	50GB-701A	1-1/2	1/8	1.50	2.05	4.22	2.81	5.40	4.21	1.81	1.31	3.62	7,745,000
50GB-801	50GB-801A	2	1/8	2.00	2.48	5.02	3.18	5.40	4.93	2.18	1.68	4.36	14,741,000
50GB-5A1	50GB-5A1A	1	1/4	1.00	1.65	3.42	2.19	4.78	3.18	1.53	0.94	3.06	3,144,000
50GB-6A1	50GB-6A1A	1-1/4	1/4	1.25	1.87	3.86	2.37	4.78	3.56	1.62	1.15	3.24	6,441,000
50GB-7A1	50GB-7A1A	1-1/2	1/4	1.50	2.05	4.22	2.81	5.40	4.21	1.81	1.31	3.62	7,745,000
50GB-8A1	50GB-8A1A	2	1/4	2.00	2.48	5.02	3.18	5.40	4.93	2.18	1.68	4.36	14,741,000

*Note: Capacities based on 1000 Btu/cubic feet gas at 0.64 specific gravity, at a P.D. of 1" W.C.



78-124/78-125 SERIES
5-PORT TANK SELECTOR

Unique ball design allows for higher flow capacities. Five port construction allows access to four tanks using only one valve.



FEATURES

- Five NPT Connections
- Bronze Ball Valve with Stainless Steel Lever and Nut
- PTFE Seats and RPTFE Stem Packing
- Stem Packing Adjustable for Wear
- Non-Lubricated
- 50 psig Pressure Rating
- Operation: Four Selected Inlets Feed One Common Outlet
- Pointer on Handle Indicates the Selected Inlet
- Easy Mounting Design

DIMENSIONS

SERIES NUMBER	SIZE (IN.)	DIMENSIONS (IN.)								WT./100 (LB.)
		A	B	C	D	E	F	G	H	
78-124-01	1/2	0.50	1.26	2.52	2.27	3.53	1.12	10-24	1.40	106
78-125-01A	3/4	0.75	1.56	3.12	2.93	3.87	1.53	1/4-20	1.98	264

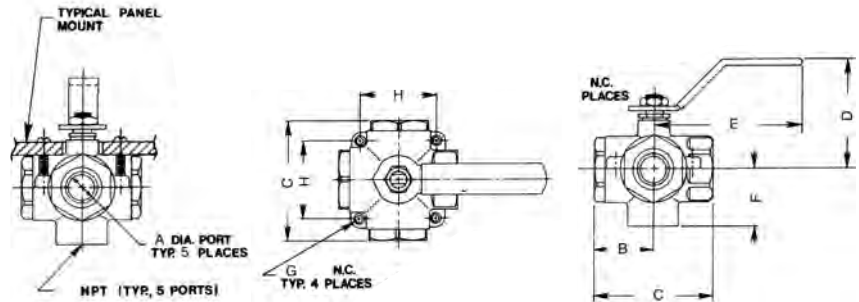

78-256 SERIES
MULTI PURPOSE SHUT-OFF VALVE WITH MOUNTING EARS

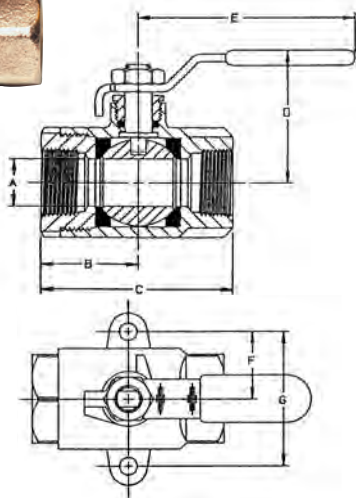
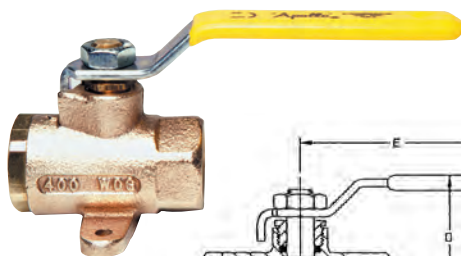

Excellent for use with liquid fuels and often specified as a fuel tank shut-off valve in marine applications. All wetted parts are brass or cast bronze. Mounting ears for easy, positive installation.

FEATURES

- 400 psig CWP, Non-Shock
- Tested to 100 psig Air Under Water
- NPT Threaded, Both Ends
- RPTFE Seats and Seals
- (-07) Tee Handle Optional

DIMENSIONS

MODEL NUMBER	SIZE (IN.)	DIMENSIONS (IN.)						
		A	B	C	D	E	F	G
78-248-01	1/4	0.43	1.12	2.25	1.78	3.87	0.93	1.87
78-250-01	3/8	0.43	1.12	2.25	1.78	3.87	0.93	1.87
78-256-01	1/2	0.50	1.12	2.25	1.78	3.87	0.93	1.87
78-438-01	3/4	0.68	1.50	3.00	2.12	4.87	1.06	2.12

77F/77FLF SERIES
FULL PORT FORGED BRASS BALL VALVE



BALL VALVES



LARGE DIAMETER



LARGE DIAMETER

OPTIONS

- (-01) Standard Lever and Trim
- (-04) 2-1/4" Stem Extension
- (-07) CS Tee Handle
- (-10) Stainless Steel Lever & Nut
- (-11) Therma-Seal™ Insulating Tee
- (-27) Stainless Steel Locking Handle
- (-50) 2-1/4" Locking Stem Extension
- 77Fx-140/240 Stainless Steel Ball & Stem

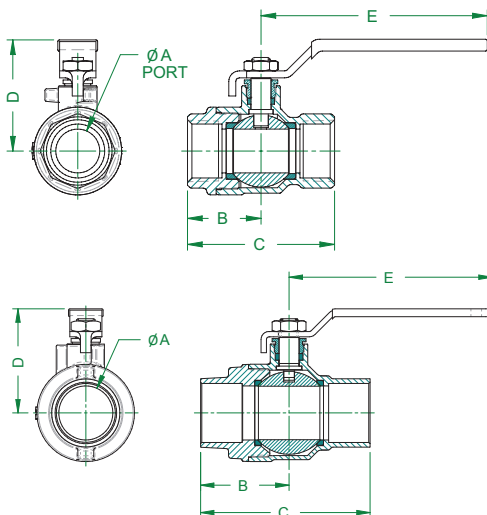

The Apollo® 77F Series is a full port forged brass ball valve suitable for a wide range of plumbing and heating applications. These NPT threaded or solder, 2-piece valves combine reliable operation with maximum economy. Valves include most pertinent agency approvals. **Proudly Made in the USA.**

FEATURES

- Heavy Pattern Forged Design
- Full Port Flow
- Superior RPTFE Seats and Packing
- Adjustable Stem Packing
- Blowout-Proof Stem
- Corrosion Resistant Materials
- 100% Factory Tested
- Popular Lever Options and Stainless Steel Trim Available
- Silicone Free Assembly
- Made in USA, ARRA compliant
- Rating: 600 CWP (1/4" - 2")
- Rating: 400 CWP (2-1/2" - 4")
- Steam Rating: 150 psi SWP
- Vacuum Service to 29 in. Hg

77FLF FEATURES

- Easily Identifiable White Handle Grip and Blue "Lead Free" Hang Tag
- EZ-Solder™ Lead Free Brass
- Lead Free DZR Brass
- NSF/ANSI 61 Water Quality
- NSF/ANSI 372 Lead Free
- Rating: 600 CWP (1/4" - 2")
- Rating: 400 CWP (2-1/2" - 4")
- Steam Rating: 150 psi SWP
- Vacuum Service to 29 in. Hg

APPROVALS

- MSS SP-110
- IAPMO IGC-157 Ball Valves
- CGA 3.16 (125 PSI)
- CGA CR91-002 (5 PSI)
- ANSI Z21.15/CSA 9.1 (1/2 PSI)
- ASME B16.44 (5 PSI)
- ASME B16.33 (125 PSI) (1/2" - 2")
- FM 1140 (1/4" - 2")
- UL Guides: YSDT, MHKZ, YQNZ, YRBX & YRPV
- UL Guide VQGU (1/4" - 2")

*Gas approvals apply to NPT models only

DIMENSIONS

MODEL NUMBER	LF MODEL NUMBER	SIZE (IN.)	DIMENSIONS (IN.)					WT. (LB.)
			A	B	C	D	E	
NPT								
77F-101-01	77FLF-101-01	1/4"	0.38	0.81	1.62	1.61	2.85	0.3
77F-102-01	77FLF-102-01	3/8"	0.38	0.85	1.70	1.61	2.85	0.3
77F-103-01	77FLF-103-01	1/2"	0.50	1.14	2.25	1.66	2.85	0.5
77F-104-01	77FLF-104-01	3/4"	0.75	1.29	2.57	1.91	3.86	0.8
77F-105-01	77FLF-105-01	1"	1.00	1.60	3.20	2.11	3.86	1.3
77F-106-01	77FLF-106-01	1-1/4"	1.25	1.73	3.46	2.44	4.75	2.1
77F-107-01	77FLF-107-01	1-1/2"	1.50	2.00	4.00	2.91	5.42	3.2
77F-108-01	77FLF-108-01	2"	2.00	2.37	4.74	3.69	7.77	5.6
77F-109-01	77FLF-109-01	2-1/2"	2.50	2.99	5.98	4.14	7.77	12.8
77F-100-01	77FLF-100-01	3"	3.00	3.52	7.05	5.03	9.92	19.7
77F-10A-01	77FLF-14A-01	4"	4.00	3.83	7.65	5.70	14.78	25.5
SOLDER								
77F-203-01	77FLF-203-01	1/2"	0.50	1.37	2.37	1.66	2.85	0.4
77F-204-01	77FLF-204-01	3/4"	0.75	1.72	3.13	1.91	3.86	0.9
77F-205-01	77FLF-205-01	1"	1.00	2.01	3.73	2.11	3.86	1.3
77F-206-01	77FLF-206-01	1-1/4"	1.25	2.07	3.97	2.44	4.75	2.0
77F-207-01	77FLF-207-01	1-1/2"	1.50	2.42	4.69	2.91	5.42	3.3
77F-208-01	77FLF-208-01	2"	2.00	2.91	5.82	3.69	7.77	5.6
77F-209-01	77FLF-209-01	2-1/2"	2.50	3.68	7.05	4.14	7.77	11.6
77F-200-01	77FLF-200-01	3"	3.00	4.26	8.15	5.03	9.92	19.3
77F-20A-01	77FLF-24A-01	4"	4.00	4.82	9.57	5.70	14.78	25.6



94A SERIES

ECONOMY FULL PORT BALL VALVE - APOLLO INTERNATIONAL™



These full port ball valves with forged brass body are UL listed and CSA approved. Ideal for general purpose non-potable applications including air, gas, HVAC, irrigation, fire protection, etc.

FEATURES

- Adjustable Stem Packing Nut
- 600 CWP Non-Shock (1/4" - 2")
- 400 CWP Non-Shock (2-1/2" - 4")
- Temperature Range: -0°F to 400°F
- Stem Seal O-Ring (Solder Ver. 1/2" - 2") **NEW!**
- 2-1/4" Stem Ext w/ Memory Stop Kit Option
- 100% Factory Tested
- Lead Free Option (94ALF-A)

APPROVALS

- MSS SP-110 - Ball Valves

CSA LISTED

- (File # 226234) per the following standards:
- ANSI Z21.15 (1/2 psi) (CSA 9.1) (1/4" - 2")
 - ASME B16.44 (5 psi) (CR91-002) (1/4" - 2")
 - ASME B16.33 (125 psi) (CGA 3.16) (1/4" - 2")

UL LISTED

- Guides YQNZ, YRBX, YRPV, YSDT and MHKZ (1/4" - 4" NPT only)
- UL 258 - VQGU Fire Protection Trim & Drain 175psi max (1/4" - 2")

FM LISTED

- FM 1140 Fire Protection Quick Opening Valves

*Gas approvals apply to NPT models only

DIMENSIONS

MODEL NUMBER	SIZE (IN.)	DIMENSIONS (IN.)					WT. (LB.)
		A	B	C	D	E	
NPT							
94A-101-01	1/4"	0.39	1.76	1.73	3.54	-	0.3
94A-102-01	3/8"	0.39	1.76	1.73	3.54	-	0.3
94A-103-01	1/2"	0.58	2.05	2.04	3.54	-	0.4
94A-104-01	3/4"	0.75	2.36	2.26	3.78	-	0.7
94A-105-01	1"	0.95	2.76	2.58	4.53	-	1.1
94A-106-01	1-1/4"	1.26	3.31	3.05	4.53	-	1.6
94A-107-01	1-1/2"	1.58	3.66	3.37	5.51	-	2.4
94A-108-01	2"	1.97	4.18	3.70	6.30	-	3.4
94A-109-01	2-1/2"	2.52	5.38	4.65	8.66	-	7.6
94A-100-01	3"	2.95	6.04	4.97	8.66	-	9.3
94A-10A-01	4"	3.95	7.39	6.13	11.02	-	16.9
SOLDER							
94A-203-01	1/2"	0.58	2.05	1.84	3.54	0.63	0.4
94A-204-01	3/4"	0.75	2.75	2.14	3.78	0.88	0.7
94A-205-01	1"	0.95	3.31	2.45	4.53	1.13	1.1
94A-206-01	1-1/4"	1.26	3.82	3.04	4.53	1.38	1.4
94A-207-01	1-1/2"	1.58	4.43	3.17	5.51	1.63	2.2
94A-208-01	2"	1.97	5.38	3.49	6.30	2.13	3.0
94A-209-01	2-1/2"	2.52	6.28	4.66	8.66	2.63	6.4
94A-200-01	3"	2.95	7.15	4.87	8.66	3.13	8.5
94A-20A-01	4"	3.95	9.28	5.87	11.02	4.13	15.8

94A OPTIONS

SIZE	REPLACEMENT HANDLES	2-1/4" STEM EXTENSION + MEMORY STOP KIT
1/4"-3/8"	W932400	78217101
1/2"	W932500	78217201
3/4"	W936000	78217301
1"	W932600	78217401
1-1/4"	W932700	78217501
1-1/2"-2"	W932800	78217601
2-1/2"-3"	W932900	78217701
4"	W933000	78217801

- Kits do not include stem nut
 - Replacement handles are not UL marked

BALL VALVES

94ALF-A SERIES

ECONOMY FULL PORT BALL VALVE - APOLLO INTERNATIONAL™

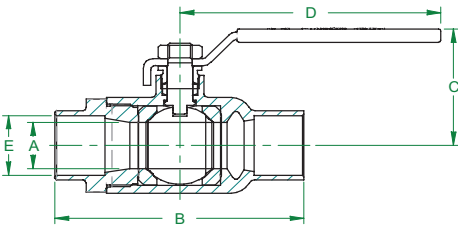
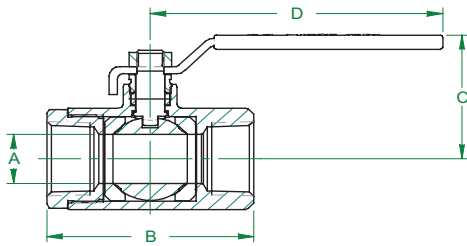

These Lead Free ball valves with forged DZR brass body are UL listed and CSA approved. Ideal for plumbing and heating, fuel gas, fire protection and other general purpose applications.

FEATURES

- Lead Free* Materials and Certification
- EZ-Solder™ Lead Free Brass
- Solders Like Standard Brass
- Distinctive White "Lead Free" Handle Grip and Blue "Lead Free" Hang Tag
- 2-Piece, Full-Port Design
- Blowout-Proof Stem
- Adjustable Stem Packing Nut
- Multiple Agency Approvals
- **Stem Seal O-Ring (Solder Ver. 1/2" - 2") NEW!**
- Valve Design Rating: 600 CWP - 1/4 to 2", 400 CWP - 2-1/2" to 4"
- Temperature Range: 0°F to 366°F
- 100% Factory Tested

APPROVALS

- MSS SP-110 - Ball Valves
- NSF/ANSI 61 Water Quality
- NSF/ANSI 372 Lead Free
- IAPMO IGC 157 (cUPC)

CSA LISTED

- (File # 226234) per the following standards:
- ANSI Z21.15 (1/2 psi) (CSA 9.1) (1/4" - 2")
 - ASME B16.44 (5 psi) (CR91-002) (1/4" - 2")
 - ASME B16.33 (125 psi) (CGA 3.16) (1/4" - 2")

UL LISTED

- Guides YQNZ, YRBX, YRPV, YSDT and MHKZ (1/4" - 4" NPT only)
- UL 258 - VQGU Fire Protection Trim & Drain 175psi max (1/4" - 2")

FM LISTED

- FM 1140 Fire Protection Quick Opening Valves

*Gas approvals apply to NPT models only

DIMENSIONS

MODEL NUMBER	SIZE (IN.)	DIMENSIONS (IN.)					WT. (LB.)
		A	B	C	D	E	
NPT							
94ALF-101-01A	1/4"	0.39	1.76	1.73	3.54	-	0.3
94ALF-102-01A	3/8"	0.39	1.76	1.73	3.54	-	0.3
94ALF-103-01A	1/2"	0.58	2.05	2.04	3.54	-	0.4
94ALF-104-01A	3/4"	0.75	2.36	2.26	3.78	-	0.7
94ALF-105-01A	1"	0.95	2.76	2.58	4.53	-	1.1
94ALF-106-01A	1-1/4"	1.26	3.31	3.05	4.53	-	1.6
94ALF-107-01A	1-1/2"	1.58	3.66	3.37	5.51	-	2.4
94ALF-108-01A	2"	1.97	4.18	3.70	6.30	-	3.4
94ALF-109-01A	2-1/2"	2.52	5.38	4.65	8.66	-	7.6
94ALF-100-01A	3"	2.95	6.04	4.97	8.66	-	9.3
94ALF-10A-01A	4"	3.95	7.39	6.13	11.02	-	16.9
SOLDER							
94ALF-203-01A	1/2"	0.58	2.05	1.84	3.54	0.63	0.4
94ALF-204-01A	3/4"	0.75	2.75	2.14	3.78	0.88	0.7
94ALF-205-01A	1"	0.95	3.31	2.45	4.53	1.13	1.1
94ALF-206-01A	1-1/4"	1.26	3.82	3.04	4.53	1.38	1.4
94ALF-207-01A	1-1/2"	1.58	4.43	3.17	5.51	1.63	2.2
94ALF-208-01A	2"	1.97	5.38	3.49	6.30	2.13	3.0
94ALF-209-01A	2-1/2"	2.52	6.28	4.66	8.66	2.63	6.4
94ALF-200-01A	3"	2.95	7.15	4.87	8.66	3.13	8.5
94ALF-20A-01A	4"	3.95	9.28	5.87	11.02	4.13	15.8

**94ALF-2xx-01A intended for soft solder installation using solders with melting temperature of < 500°F.

94ALF-A OPTIONS

SIZE	REPLACEMENT HANDLES	2-1/4" STEM EXTENSION + MEMORY STOP KIT
1/4"-3/8"	W234700	78217101
1/2"	W234800	78217201
3/4"	W234900	78217301
1"	W235000	78217401
1-1/4"	W235100	78217501
1-1/2"-2"	W235200	78217601
2-1/2"-3"	W235300	78217701
4"	W273800	78217801

- Kits do not include stem nut
- Replacement handles are not UL marked



95ALF SERIES

LEAD FREE FULL PORT STOP & WASTE BALL VALVE

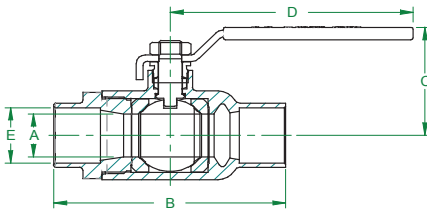
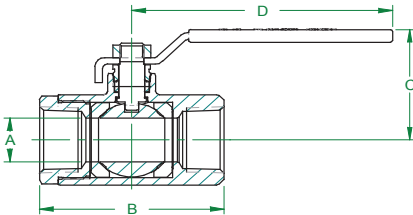

The **Apollo International™** 95ALF Lead Free forged DZR brass ball valves combine reliable operation with maximum economy. Ideal for plumbing or hydronic systems where draining is required. Valves are certified by IAPMO and ANSI 3rd party certified lead free.

FEATURES

- Lead Free Materials and Certification
- Blowout-Proof Stem Design
- Adjustable Stem Packing Nut
- Drain Port with Finger Tight Shut-Off
- Convenient, Quarter-Turn Operation
- EZ-Solder™ Lead Free Brass Alloy
- Solders Like Standard Brass
- Valve Design Rating: 600 CWP
- Temperature Range: 32°F to 250°F
- IAPMO IGC157
- NSF/ANSI 61 Water Quality
- NSF/ANSI 372 Lead Free

DIMENSIONS

LF MODEL NUMBER	SIZE (IN.)	DIMENSIONS (IN.)				
		A	B	C	D	E
NPT						
95ALF-103-01	1/2	0.59	2.24	1.78	3.74	-
95ALF-104-01	3/4	0.79	2.53	2.09	3.94	-
95ALF-105-01	1	0.98	3.15	2.36	4.33	-
SOLDER						
95ALF-203-01	1/2	0.59	2.12	1.78	3.74	0.63
95ALF-204-01	3/4	0.79	2.87	1.94	3.94	0.88
95ALF-205-01	1	0.98	3.53	2.36	4.33	1.13

***95ALF-2xx-01 intended for soft solder installation using solders with melting temperature of < 500°F.*

77W SERIES

APOLLOPRESS® BRONZE FULL PORT BALL VALVE

New! Higher Pressure Rating



Apollo® 77W Series APOLLOPRESS® ball valves install in seconds, but the valve and the connection are made to last. Ideal for mechanical and heating systems. Not for use with natural gas or potable water.

FEATURES

- Full Port
- Ridgid® XL Press Tool Compatible
- Leak Before Press® Technology
- **300 CWP, Non-Shock to 250°F max. NEW!**
- MSS SP-110 Ball Valves
- Adjustable Stem Packing
- Excellent for Hydronic Heating (90% Glycol max)
- Popular Lever Options and Stainless Steel Trim Available
- **Made in the USA**

DIMENSIONS

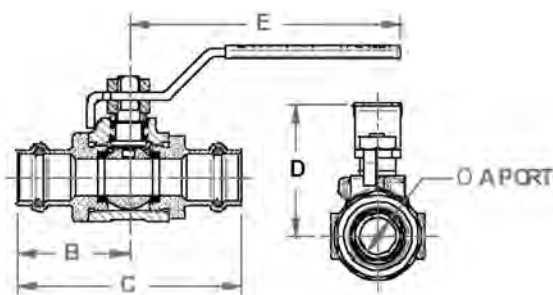

MODEL NUMBER	SIZE (IN.)	DIMENSIONS (IN.)					WT. (LB.)
		A	B	C	D	E	
77W-103-01	1/2	0.50	1.54	3.08	1.50	3.74	0.6
77W-104-01	3/4	0.75	1.78	3.55	2.01	4.78	1.1
77W-105-01	1	1.00	1.93	3.86	2.20	4.78	1.8
77W-106-01	1-1/4	1.25	2.44	4.87	3.13	7.04	4.3
77W-107-01	1-1/2	1.50	2.91	5.81	3.10	7.04	4.6
77W-108-01	2	2.00	3.74	7.47	3.48	7.04	8.2

77WLF SERIES

APOLLOPRESS® LEAD FREE BRONZE FULL PORT BALL VALVE

LEADFREE CERTIFIED

New! Higher Pressure Rating



Apollo® 77WLF Series APOLLOPRESS® ball valves install in seconds, but the valve and the connection are made to last. Ideal for mechanical and heating systems. Not for use with natural gas.

FEATURES

- Full Port
- Ridgid® XL Press Tool Compatible
- Leak Before Press® Technology
- **300 CWP, Non-Shock to 250°F max. NEW!**
- MSS SP-110 Ball Valves
- NSF/ANSI 61 Water Quality
- NSF/ANSI 372 Lead Free
- Adjustable Stem Packing
- Excellent for Hydronic Heating (90% Glycol max)
- Popular Lever Options and SS Trim Available
- **Made in the USA**

DIMENSIONS

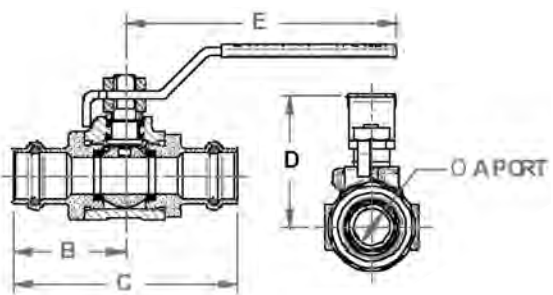

MODEL NUMBER	SIZE (IN.)	DIMENSIONS (IN.)					WT. (LB.)
		A	B	C	D	E	
77WLF-103-01	1/2"	0.50	1.54	3.08	1.50	3.74	0.61
77WLF-104-01	3/4"	0.75	1.78	3.55	2.01	4.78	1.09
77WLF-105-01	1"	1.00	2.12	4.24	2.20	4.78	1.77
77WLF-106-01	1-1/4"	1.25	2.61	5.22	3.13	7.04	4.27
77WLF-107-01	1-1/2"	1.50	2.96	5.92	3.10	7.04	4.63
77WLF-108-01	2"	2.00	3.74	7.47	3.48	7.04	8.21



77W-HC SERIES

APOLLOPRESS® BRONZE HOSE CAP & CHAIN BALL VALVE



New! Higher Pressure Rating

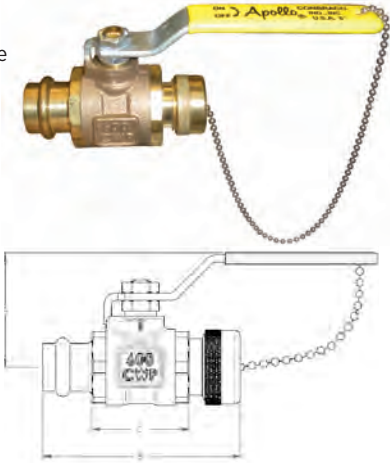

Designed for direct mechanical connection to ASTM B88-Type K, L, and M copper tubing in the hard drawn condition for sizes 1/2"-3/4". Valves feature a 3/4" hose thread connection with heavy brass cap to protect the threads and is full pressure rated. Not for use with natural gas.

FEATURES

- Full Port
- Ridgid® "XL" Press Tool Compatible
- Leak Before Press® Technology
- MSS SP-110 Ball Valves
- NSF/ANSI 61 (77WLF-HC)
- Adjustable Stem Packing
- **300 CWP, Non-Shock to 250°F max. NEW!**
- Excellent for Hydronic Heating (90% Glycol max)
- Compatible with Most 77C Series Options
- Heavy Brass Dust Cover is Full Pressure Rated
- Popular Lever and Trim Options Available
- **Now with Stronger Stainless Steel Ball Chain NEW!**
- **Proudly Made in USA**

DIMENSIONS

MODEL NUMBER	LF MODEL NUMBER	SIZE (IN.)	DIMENSIONS (IN.)			WT. (LB.)
			A	B	C	
77W-103-HC	77WLF-103-HC	1/2	1.80	3.12	1.54	0.61
77W-104-HC	77WLF-104-HC	3/4	2.01	3.45	1.72	1.09

BALL VALVES

77V SERIES

APOLLOPRESS® BRASS BALL VALVE



New! Higher Pressure Rating

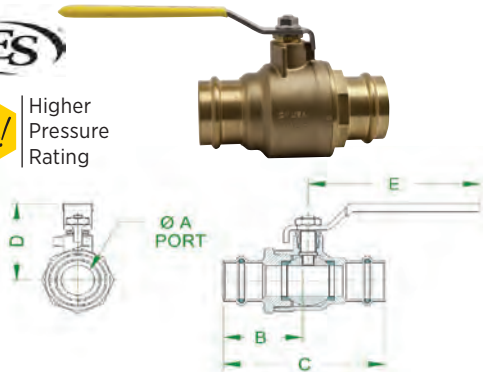

The APOLLOPRESS® 77V Series two-piece press ball valve is ideal for installation in most HVAC systems. Features Leak Before Press® technology and 300 psig maximum working pressure. Proudly Made in the USA.

FEATURES

- 2 Piece, Heavy Pattern Forged Design
- Full Port Flow
- **Max. Operating Pressure 300 psi NEW!**
- Temperature Range: 0°F to 250°F
- Superior RPTFE Seats and Packing
- Adjustable Stem packing
- Ridgid® XL Press Tool Compatible
- 2-1/2" - 4" are XLC Compatible
- Blowout-Proof Stem
- Corrosion Resistant Materials
- Silicone Free Assembly
- 100% Factory Tested
- MSS SP-110 Ball Valves
- Directive 2011/65/CE (RoHS)
- Popular Lever Options and SS Trim Available
- **Proudly Made in USA, ARRA Compliant**

DIMENSIONS

MODEL NUMBER	SIZE (IN.)	DIMENSIONS (IN.)					WT. (LB.)
		A	B	C	D	E	
77V-103-01	1/2"	0.50	1.57	2.89	1.66	2.85	0.4
77V-104-01	3/4"	0.75	1.90	3.63	1.91	3.86	0.9
77V-105-01	1"	1.00	2.20	3.88	2.11	3.86	1.2
77V-106-01	1-1/4"	1.25	2.23	4.22	2.44	4.75	2.3
77V-107-01	1-1/2"	1.50	2.84	5.45	2.91	5.42	3.4
77V-108-01	2"	2.00	3.40	6.57	3.69	7.77	6.0

LARGE DIAMETER

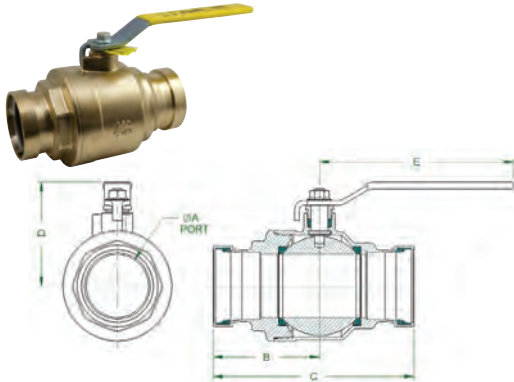

77VLF SERIES

APOLLOPRESS® LEAD FREE BRASS BALL VALVE



New!

Higher Pressure Rating

BALL VALVES

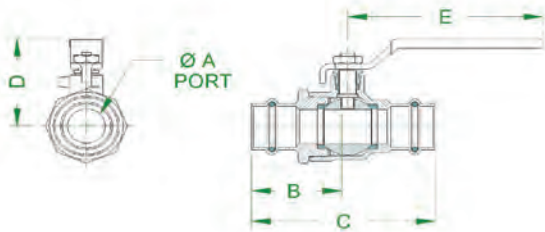

LARGE DIAMETER

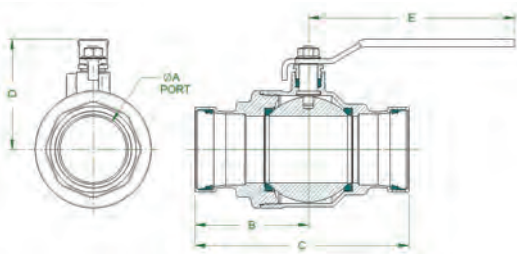

The APOLLOPRESS® 77VLF Series Lead Free two-piece press ball valve is ideal for installation in most plumbing and heating systems, including potable water. Features Leak Before Press® technology and 300 psig maximum working pressure. Proudly Made in the USA.

FEATURES

- Lead Free, ANSI 3rd Party Certified
- 2 Piece, Heavy Pattern Forged Design
- Dezincification resistant Materials
- Easily Identifiable White Handle Grip and Blue "Lead Free" Hang Tag
- Full Port flow
- Superior RPTFE Seats and Packing **NEW!**
- Adjustable Stem Packing
- Ridgid® XL Press Tool compatible
- 2-1/2" - 4" are XLC Compatible
- Blowout-Proof Stem
- Silicone Free Assembly
- 100% Factory Tested
- Maximum Operating Pressure: 300 psi **NEW!**
- Temperature Range: 0°F to 250°F
- MSS SP-110 Ball Valves
- NSF/ANSI 61 Water Quality
- NSF/ANSI 372 Lead Free
- IAPMO IGC-157 Ball Valves
- Directive 2011/65/CE (RoHS)
- Popular Lever Options and SS Trim Available
- Proudly Made in USA, ARRA Compliant

DIMENSIONS

MODEL NUMBER	SIZE (IN.)	DIMENSIONS (IN.)					WT. (LB.)
		A	B	C	D	E	
77VLF-103-01	1/2"	0.50	1.57	2.89	1.66	2.85	0.4
77VLF-104-01	3/4"	0.75	1.90	3.63	1.91	3.86	0.9
77VLF-105-01	1"	1.00	2.20	3.88	2.11	3.86	1.2
77VLF-106-01	1-1/4"	1.25	2.23	4.22	2.44	4.75	2.3
77VLF-107-01	1-1/2"	1.50	2.84	5.45	2.91	5.42	3.4
77VLF-108-01	2"	2.00	3.40	6.57	3.69	7.77	6.0
77VLF-109-01	2-1/2"	2.50	4.26	8.04	4.13	7.77	12.0
77VLF-100-01	3"	3.00	5.10	9.45	5.03	9.92	19.5
77VLF-14A-01	4"	4.00	5.20	10.35	5.70	14.78	26.0



94VLF-A SERIES

APOLLOPRESS® LEAD FREE BALL VALVE



The CONBRACO™ INTERNATIONAL 94VLF Series Lead Free two-piece press ball valve is ideal for installation in most plumbing and heating systems, including potable water.

FEATURES

- Lead Free, ANSI 3rd Party Certified
- Full Port Flow
- PTFE Seats and Packing
- Adjustable Stem Packing
- Ridgid® XL Press Tool Compatible
- 2-1/2" - 4" are XLC Compatible
- Corrosion Resistant Materials
- 100% Factory Tested
- 2 Year Warranty
- -A Model with Shorter Lay Length and Leak Before Press® Technology **NEW!**

APPROVALS

- MSS SP-110 Ball Valves
- NSF/ANSI 61 Water Quality
- NSF/ANSI 372 Lead Free
- IAPMO IGC-157-2013 Ball Valves

APPROVED APPLICATIONS

- Water (Including Potable Water)
- Hydronic Heating (90% Glycol max)
- Not Suitable for Flammable Gas Service
- Designed for Direct Mechanical Connection to ASTM B88-Type K, L, and M Copper Tubing in the Hard Drawn Condition
- Not Compatible with Soft Annealed Copper Tubing

PERFORMANCE RATING

- Maximum Operating Pressure 250 psig
- Temperature Range: 0°F to 250°F

DIMENSIONS

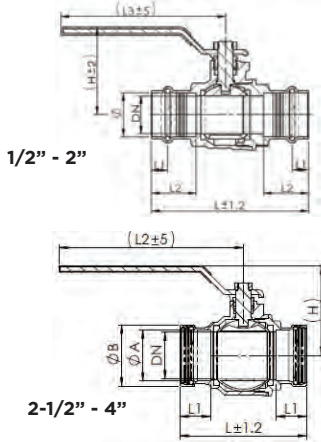

MODEL NUMBER	SIZE (IN.)	DIMENSIONS (IN.) (MM)									2-1/4" STEM EXTENSION KIT
		DN	Ø	A	B	L	L1	L2	L3	H	
94VLF-103-01A	1/2"	14.5	0.63 (16.1)	-	-	3.41 (86.6)	0.43 (11)	1.1 (28)	3.82 (97)	1.66 (42.2)	78266101
94VLF-104-01A	3/4"	19	0.86 (22.5)	-	-	3.85 (97.9)	0.43 (11)	1.18 (30)	3.82 (97)	1.92 (48.7)	78266201
94VLF-105-01A	1"	25	1.13 (28.8)	-	-	4.13 (105)	0.43 (11)	1.18 (30)	4.41 (112)	2.3 (58.5)	78266301
94VLF-106-01A	1-1/4"	32	1.39 (35.2)	-	-	4.59 (116.5)	0.43 (11)	1.18 (30)	5.2 (132)	2.73 (69.3)	78266401
94VLF-107-01A	1-1/2"	39	1.63 (41.5)	-	-	5.16 (131.1)	0.51 (13)	1.38 (35)	5.2 (132)	2.93 (74.5)	78266501
94VLF-108-01A	2"	50	2.13 (54.2)	-	-	6.00 (152.5)	0.63 (16)	1.57 (40)	6.44 (163.5)	3.46 (88)	78266601
94VLF-109-01A	2-1/2"	61.5	-	2.64 (67)	3.15 (80)	6.5 (165)	1.57 (40)	9.45 (240)	-	4.61 (117)	78266701 (Q2 2018)
94VLF-100-01A	3"	73.5	-	3.13 (79.6)	3.66 (93)	7.38 (187.5)	1.77 (45)	9.45 (240)	-	4.96 (126)	78266801 (Q2 2018)
94VLF-10A-01A	4"	97.5	-	4.14 (105.1)	4.69 (119)	9.21 (234)	2.13 (54)	9.45 (240)	-	5.91 (150)	78266901 (Q2 2018)

* ± tolerances shown apply only to mm, not inches

94XLF SERIES

PEX BALL VALVE

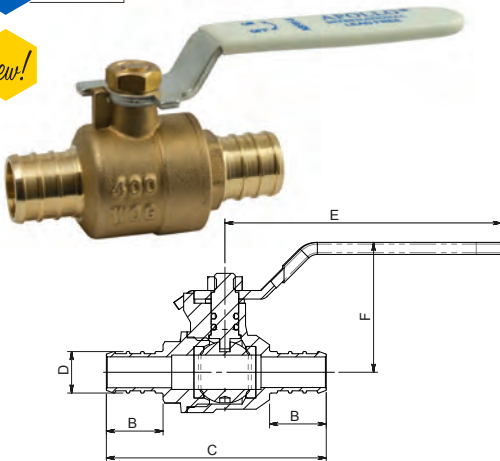

The Apollo International™ 94XLF Lead Free DZR forged brass ball valves combine reliable operation with maximum economy. Ideal for plumbing and heating applications including potable water. Valves are ANSI 3rd party lead free certified and listed to NSF 14, NSF 61 and NSF 372.

FEATURES

- Lead Free DZR Materials and Certification
- ASTM F1807 PEX Design
- Easily Identifiable "Lead Free" White Handle Grip
- Double O-Ring Stem Seal
- Blowout-Proof Stem Design
- Silicone Free Assembly

DIMENSIONS

MODEL NUMBER	SIZE (IN.)	DIMENSIONS (IN.)					WT. (LB.)
		B	C	D	E	F	
94XLF-103-01	1/2	0.65	2.52	.47	3.17	1.49	.25
94XLF-104-01	3/4	0.65	2.62	.67	3.17	1.57	.41
94XLF-105-01	1	0.80	2.91	.86	3.17	1.57	.57



AF-OLLO
S/A USA

"Apollo"[®]

VALVE ACTUATION OPTIONS C-5

RESILIENT SEATED BUTTERFLY VALVES

DUCTILE IRON C-3 - C-15
CAST IRON C-3 - C-15

HIGH PERFORMANCE BUTTERFLY VALVES

CARBON STEEL C-16 - C-26
STAINLESS STEEL C-16 - C-26
NICKEL ALLOYS C-16 - C-26

BUTTERFLY VALVES





STANDARD MATERIALS LIST

1	BODY	Ductile Iron ASTM A536 (65-45-12)
2	SEAT	EPDM* Buna-N (Nitrile)* Viton®B*
3	SHAFT	416 Stainless Steel ASTM A564 316 Stainless Steel (Optional)
4	DISC	Nickel Plated Ductile Iron ASTM A536 (65-45-12) Aluminum-Bronze ASTM B148, C95400 316 Stainless Steel ASTM A351, Type CF8M
5	BUSHING	Glass Reinforced Epoxy
6	STEM SEAL	Buna-N (Nitrile)
7	RETAINER	Steel w/ Protective Finish
8	WASHER	Brass
9	SET SCREWS (FLAT POINT or CONE POINT)	Steel w/ Protective Finish
10	NAMEPLATE	

WD141 - Wafer Design Shown

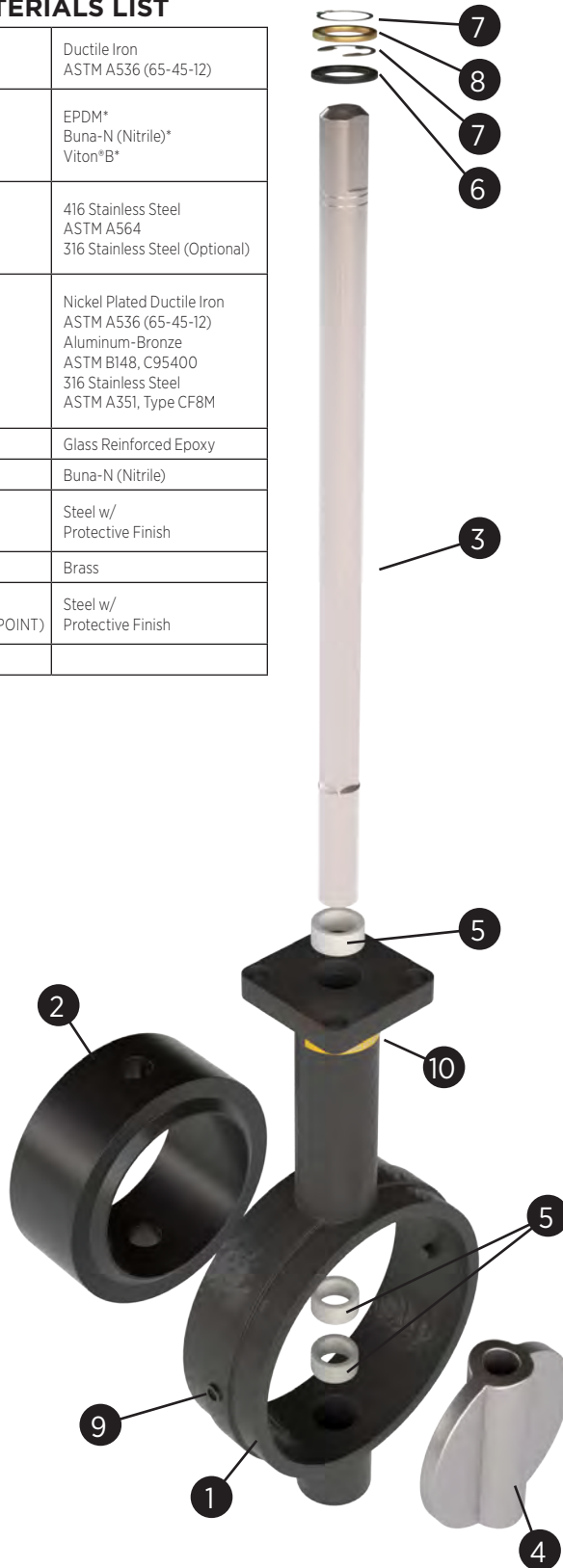

PRESSURE RATING

- 2" - 12": 200 psi
- 14" - 24": 150 psi

APOLLO INTERNATIONAL™

- WD141: One-Piece Wafer-Style, Sizes 2" - 12"
- LD141: Lug Valves, Sizes 2" - 24"

APOLLO® ASSEMBLED & TESTED IN USA

- WD145: One-Piece Wafer-Style, Sizes 2" - 12"
- LD145: Lug Valves, Sizes 2" - 12"

CERTIFICATION

- Certified to NSF/ANSI 372 Lead Free and NSF/ANSI 61 Water Quality*
- Registered Under Canadian Registration Number CRN# 0C12102.8CL

*NSF 61 does not apply to ductile iron disc option

BODY DESIGN

- Ductile Iron ASTM A536
- WD Model: A One-Piece Wafer Design with Flange Locating Holes in Larger Sizes (8" to 12")
- LD Model: Valves are Full Lug with Tapped Lugs, to ANSI 125/150 Drilling. Face-to-Face Dimensions Meet Universal Interchangeability Standards Outlined in MSS SP-67 and API 609
- Models Come Equipped with an Extended Neck Providing at least 2" Clearance Between the Valve Top Plate and Pipe Flange to Allow Ease of Insulation Installation

BLOWOUT-PROOF SEAT WITH MOLDED IN STIFFENER RING

- Isolates Body from Process Media
- Valves are Equipped with a Stretch-Resistant, Non-Collapsible Blowout-Proof Seat
- Phenolic Stiffener Ring (2"-12")
- Aluminum Stiffener Ring (14"-24" LD141 Only)

SEAT - NO GASKETS REQUIRED

- Seat Design Eliminates the Need for Flange Gaskets
- Installs between standard ANSI 125/150 Flanges

MOUNTING FLANGE FOR ACTUATOR

- ISO 5211 Standard Cast in Top Plate
- Designed to Dimensions for Easy Mounting of Apollo® Actuators and Manual Operators

THROUGH SHAFT

- Assures Positive Disc Positioning and Dependable Performance

STEM SEAL

- Shaft Equipped with Weather Seal to Prevent External Media from Entering the Shaft Bore

SQUARE SHAFT-TO-DISC CONNECTION

- Provides a Robust Shaft-to-Disc Connection Without Pins or Bolts
- Easy Maintenance

THREE BUSHINGS

- Supports Shaft at Three Locations to Enhance Shaft Alignment and Absorb Actuator Side Thrusts

PROFILED DISC DESIGN

- Precision Machined Disc Edge Creates Bubble Tight shutoff, Primary Seal
- Polished Disc Edge Ensures Long Seat Life, Minimal Torque

SHAFT SEAL

- The Shaft Diameter is Greater than the Diameter of the Seat's Shaft Hole Creating a Robust Shaft Seal
- The Stiffening Ring Molded into the Seat Guards Against Distortion, a Frequent Cause of Shaft Leakage

END OF LINE SERVICE

- All LD Model Valves are Equipped with Retainer Screws for Dead End service: 2"-12" to 200 psig | 14"-24" to 150 psig with -A

TESTING

- All Valves are 100% Factory Tested Before Shipping

BUTTERFLY VALVES



LD/WD 141 & LD/WD 145 SERIES

SPECIFICATIONS

WD - DUCTILE IRON, WAFER BODY LD - DUCTILE IRON, SINGLE FLANGE, LUG BODY

- Designed to Fully Comply with **MSS SP-25, MSS SP-67, and API 609**
- Meets the Intent and Passed AWWA C-504 Section 5* Proof of Design Tests
- NSF/ANSI 372 "Lead Free" in Compliance with the U.S. Safe Drinking Water Act effective January 4, 2014
- NSF/ANSI 61 "Water Quality" (Bronze and Stainless Steel Disc and EPDM and Buna-N (Nitrile) Seats Only)
- Extended Neck to Allow up to 2" of Insulation
- Dead-End Service: Lug Style Valves are Suitable for End of Line Service to their Rated Pressure Without the Use of a Downstream Flange (2" - 24" only with -A)
- Ideal for ON/OFF and Throttling Service
- Designed for Extended Service with Minimal Wear and Maintenance. No Regular Lubrication is Necessary
- Compatible with ASME Class 125 and Class 150 Weld Neck or Slip-On Flanges
- Larger Wafer Body Design Includes Four Alignment Holes 8" to 12" (DN200 to DN300) WD Models
- Epoxy Powder Coating:
Resistant to Ultra-Violet Radiation Resists a Broad Range of Chemicals Including Dilute Acids, Alkalis, Solvents, Alcohols, Greases, and Oils. Resists Most Impacts Without Chipping or Cracking
- Cartridge Style Seat:
Isolates Body and Stem from the Media Provides Mating Flange Seals Eliminating the Need for Separate Flange Gaskets Provides Positive Shut-Off of Line Media at Rated Pressures
- Profiled Disc Design Assures Bubble-Tight Shut-Off, Minimal Torque and Longer Seal Life
- Double-D Shaft Drive 2" to 14" (DN50 - DN350) Round and Keyed Shaft Drive 16" to 24" (DN400 - DN600)
- Blowout-Proof Shaft
- Upper and Lower Shaft Bearing Ensure Longer Seat Life and Lower Operating Torque
- Actuator Mounting Flange (top plate) Conforms to ISO 5211 Which Allows Choice of Lever Operators, Gears and Direct Mounting of Many Apollo® Pneumatic and Electric Actuators

*Specification Applies to 3" - 24" Valves

SIZE RANGE

- 141 Series: Apollo International™
- WD141 (Wafer Body Design): 2"-12" (DN50 - DN300)
- LD141 (Single Flange Body Design): 2"-24" (DN50 - DN600)
- LD141 (Single Flange Body Design): 28"-48" (DN700 - DN1200)
- 145 Series: Assembled & Tested in USA
- WD145 (Wafer Body Design): 2"-12" (DN50 - DN300)
- LD145 (Single Flange Body Design): 2"-12" (DN50 - DN300)

PRESSURE-TEMPERATURE RATING AT 100°F (37.8°C)

- All Body, Disc, Seat Combinations
- 2"-12" (DN50 - DN300) 200 psi (13.8 bar)
- 14"-24" (DN350 - DN600) 150 psi (10.3 bar)
- 28"-48" (DN700 - DN1200)
- All Sizes - Vacuum Rating 29 in. Hg (737 mm Hg)

TEMPERATURE RATING - SEATS

- EPDM -20° F to 250° F Intermittent,
225° F Continuous (-29° C to 107° C)
- Buna-N (Nitrile) 10° F to 180° F (-12° C to 82° C)
- Viton® B -20° F to 300° F (-29° C to 149° C)

FLANGE DRILLING

- ANSI 125/150 Drilling Standard
- WD - Wafer Body Design: 8" to 12" (DN200 to DN300) Include Two Alignment Holes

TESTING

- Every LD and WD is fully tested prior to shipment. Testing includes a body shell test, a seat test, and a cycling test to insure proper functioning of moving parts. Additional testing is also available. Please let us know your requirements.

SHUTOFF PERFORMANCE

- Zero Leakage. Bi-directional, Bubble Tight. All Sizes
- ANSI/FCI 70-2 establishes a series of six leakage classes for control valves and defines the test procedure. Class VI allows the least leakage. LD's and WD's are bubble tight, which exceeds Class VI requirements.



OPTIONS

The following options are available factory installed on any of the LD or WD Series Apollo® Butterfly Valves.

The LC149 series are available either with the standard 10-position handle or with the optional gear operator on sizes 8" and larger. The other options may be purchased in kit form and installed by the user or distributor.

BARE STEM (MODEL CODE SUFFIX 0)

Select this suffix to specify a butterfly valve without a handle, gear operator or actuator.

TEN (10) POSITION HANDLE (SUFFIX 1)

The 10 position handle is the most common manual operator for valves 8" and smaller. (It can be specified on valves through 12" size.) The 10 position handle allows the valve to be set in any one of ten positions between fully open and fully closed (approximately 10 degree increments).



GEAR OPERATOR (SUFFIX 2)

Although this option is available for any size of valve, it is commonly used on valves larger than 6", and is the only manual option offered for valves 14" and larger. All gear operators feature a self-locking design preventing back driving of the gear and drifting in the disc's position. All gear operators are weather resistant and permanently lubricated. They are equipped with position indicators and adjustable travel stops.

INFINITE POSITION HANDLE W/ MEMORY STOPS (SUFFIX 3)

This option allows the valve to be set at any degree of open and is available for valves 2" through 12".

LOCKING HANDLE WITH 10 POSITION PLATE (SUFFIX 4)

The option adds a locking device to "suffix 1".



GEAR OPERATOR W/ CHAINWHEEL (SUFFIX 5)

A manual gear with chainwheel allows an overhead valve to be opened or closed from a location lower than the valve.



LOCKING GEAR OPERATOR (SUFFIX 7)

A manual gear with lock-out option allows the manual gear to be locked with a padlock.

LOCKING GEAR OPERATOR W/CHAINWHEEL (SUFFIX 8)

Combination of both chainwheel operator (suffix 5) and the locking device (suffix 7) are also available to work in conjunction with the gear operators described under "suffix 2".

SELF LOCKING GEAR OPERATORS

Self locking manual gear operators are available for all Apollo® WD and LD Series butterfly valves for heavy duty ON/OFF and throttling service. Gear operators are completely weatherproof and self-lubricating; they're equipped with position indicators and adjustable travel stops. Chainwheel operators are available. **All units feature 12" handwheels with gearing for each size to keep rim pull at 50# or less.**

HANDLE AND NOTCH PLATE KITS

Handle and notch plate kits are supplied for manual operation, ON/OFF and throttling service. Kit provides positive disc position indication for 2" to 12" WD and LD Series butterfly valves. Locking handle and infinite position handle are also available.

APOLLO® ACTUATORS

Apollo® Actuators are available as double acting or as spring return and come with a wide variety of corrosion resistant coatings for use in most any application. Standard features include external travel stop adjustments, high temperature, low friction bearings and seals. Mounting kits are available for ease of installation.



Butterfly valves require pneumatic or electric actuators with dual (open & close) limit stops.

BUTTERFLY VALVES



Apollo® butterfly valves are designed for installation between ANSI Class 125/150 lb. weld-neck or slip-on flanges. While we suggest use of weld neck flanges, Apollo® models are configured to also accept slip-on flanges that eliminate failures associated with conventional butterfly valves. Be sure to properly align flange and valve when using raised face flanges. Type C stub end flanges are not recommended.

Apollo® butterfly valves can be used with schedule 40 and schedule 80 steel pipe. When the valve is properly centered between flanges, the disc of an open butterfly valve will not contact the inside diameter of schedule 40 or schedule 80 steel pipe.

Caution: Adjacent piping and components with reduced inside diameters (Lined pipe, Schedule 80 plastic pipe, As-cast rough fittings, etc) could cause disc-pipe contact which could damage the valve's disc and shaft.

INSTALLING WD/LD SERIES VALVES

Begin by positioning the disc at partially open; maintain the disc within the body face-to-face. After positioning the valve body between flanges, install flange bolts.

DO NOT USE FLANGE GASKETS. Before tightening flange bolts, adjust disc to the full open position. This helps assure proper alignment and clearance between the outside diameter of the disc and the inside diameter of the pipe. Hand tighten the bolts and then wrench tighten in stages following the proper sequential bolt order for the flange. After tightening, rotate disc carefully to closed position to assure proper outside diameter clearance.

MAINTENANCE

Apollo® butterfly valves are designed for extended service with minimal wear and servicing. No regular lubrication is needed. In case of replacement, put disc in a near closed position and remove from line, spread flanges and support the valve while removing flange bolts.

Always depressurize a piping system when removing a manual or power actuator or performing valve maintenance.

For additional details see appropriate Installation Operation & Maintenance Manual.
(LD141 - I979900, LD145 - I981800, LC149 - I980700)

BUTTERFLY VALVES

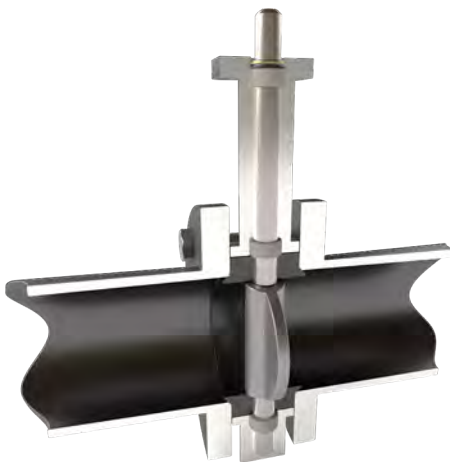

CLOSED

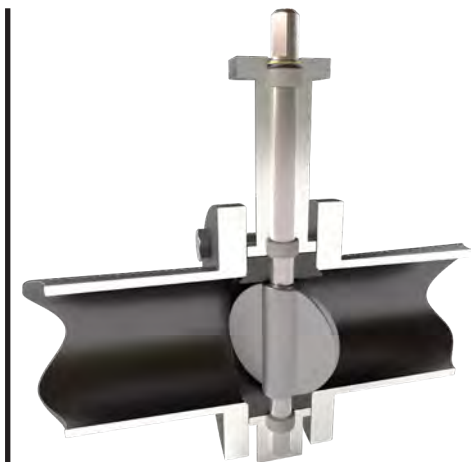

PARTIALLY OPEN



OPEN



LD MODEL

2" - 12"

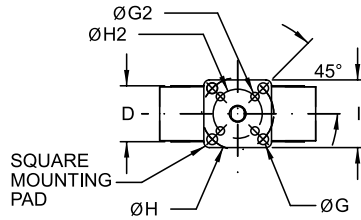

14" - 24"

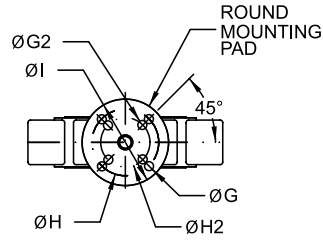

Shaft Drive:
Double-D

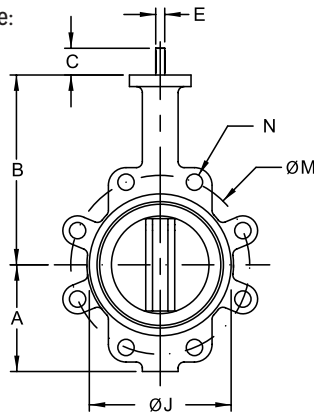

**SHAFT DRIVE:
DOUBLE-D (14")
ROUND & KEYED (16" &
LARGER)**

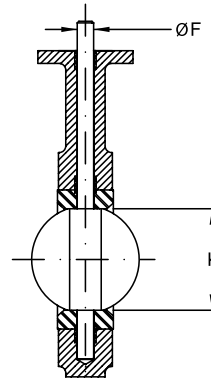

BUTTERFLY VALVES

WD MODEL

2" - 12"

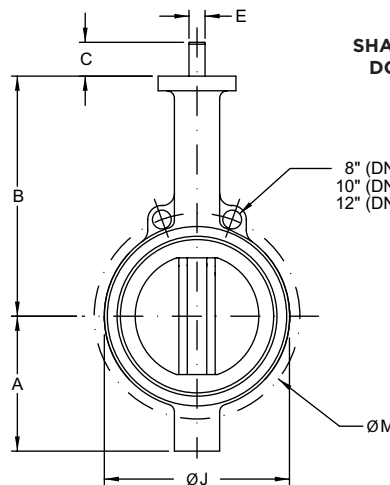
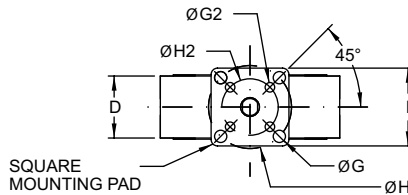

**SHAFT DRIVE:
DOUBLE-D**

8" (DN 200) : 2 HOLES, 0.98" DIAMETER
10" (DN 250) : 2 HOLES, 0.98" DIAMETER
12" (DN 300) : 2 HOLES, 0.98" DIAMETER



LD/WD 141 & LD/WD 145 SERIES DIMENSIONS

DIMENSIONS

SIZE INCHES	SIZE DN	DIMENSIONS IN INCHES - 141 & 145 SERIES								
		A	B	C	D	E	ØF	ØG	ØG2	KEY
2	50	3.25	6.38	1.25	1.75	0.394	0.496	0.375	--	--
2-1/2	65	3.75	6.88	1.25	1.88	0.394	0.496	0.375	--	--
3	80	4.00	7.13	1.25	1.88	0.394	0.496	0.375	--	--
4	100	4.88	7.88	1.25	2.13	0.472	0.621	0.375	--	--
5	125	5.38	8.38	1.25	2.25	0.551	0.745	0.375	--	--
6	150	5.88	8.88	1.25	2.25	0.551	0.745	0.375	--	--
8	200	7.13	10.25	1.75	2.50	0.669	0.870	0.563	0.438	--
10	250	8.25	11.50	1.88	2.75	0.866	1.120	0.563	0.438	--
12	300	9.75	13.25	1.88	3.13	0.945	1.244	0.563	--	--
14	350	11.00	14.50	1.88	3.13	0.945	1.244	0.563	--	--
16	400	12.00	15.75	2.00	3.50		1.313	0.563	--	.313 sq
18	450	14.38	16.63	2.00	4.25		1.500	0.813	--	.375 sq
20	500	14.63	18.88	2.50	5.25		1.625	0.813	--	.375 sq
24	600	18.00	22.13	2.75	6.13		2.000	0.813	--	.500 sq

BUTTERFLY VALVES

DIMENSIONS

SIZE INCHES	DIMENSIONS IN INCHES - 141 & 145 SERIES								
	ØH	ØH2	ØI	ØJ	K	L	M	N (# HOLES)	N (TAP UNC)
2	2.756	--	2.70	4.00	2.09	1.113	4.75	4	.625-11
2-1/2	2.756	--	2.70	4.75	2.54	1.706	5.50	4	.625-11
3	2.756	--	2.70	5.13	3.09	2.450	6.00	4	.625-11
4	2.756	--	2.70	6.75	4.09	3.488	7.50	8	.625-11
5	2.756	--	2.70	7.75	4.85	4.296	8.50	8	.750-10
6	2.756	--	2.70	8.63	6.13	5.697	9.50	8	.750-10
8	4.921	4.015	4.61	10.56	7.89	7.468	11.75	8	.750-10
10	4.921	4.015	4.61	13.06	9.89	9.484	14.25	12	.875-9
12	4.921	--	4.61	16.00	11.89	11.456	17.00	12	.875-9
14	4.921	--	Ø5.91	17.13	13.38	13.000	18.75	12	1.00-8
16	4.921	--	Ø5.91	20.00	15.38	14.970	21.25	16	1.00-8
18	6.496	--	Ø8.27	21.38	17.38	16.847	22.75	16	1.125-7
20	6.496	--	Ø8.27	23.31	19.38	18.650	25.00	20	1.125-7
24	6.496	--	Ø8.27	27.88	23.38	22.558	29.50	20	1.125-7

APPROXIMATE WEIGHT FOR BARE SHAFT VALVE

VALVE SIZE		WD MODEL LB (KG)	LD MODEL LB (KG)
INCHES	DN		
2	50	6 (2.7)	8 (3.6)
2.5	65	6 (2.7)	10 (4.5)
3	80	7 (3.2)	11 (5.0)
4	100	11 (5.0)	17 (7.7)
5	125	13 (5.9)	20 (9.1)
6	150	16 (7.3)	23 (10.4)
8	200	29 (13.2)	39 (17.7)

VALVE SIZE		WD MODEL LB (KG)	LD MODEL LB (KG)
INCHES	DN		
10	250	44 (20.0)	62 (28.1)
12	300	70 (31.8)	97 (44.0)
14	350		148 (67.1)
16	400		206 (93.4)
18	450		277 (125.6)
20	500		410 (186.0)
24	600		592 (268.5)



141 & 145 SERIES

HANDLE & GEAR DIMENSIONS

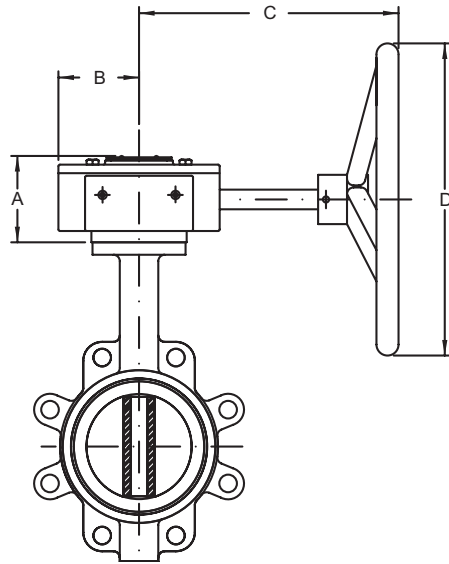

WITH MANUAL GEAR

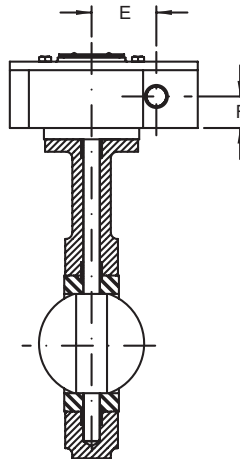

WITH MANUAL GEAR

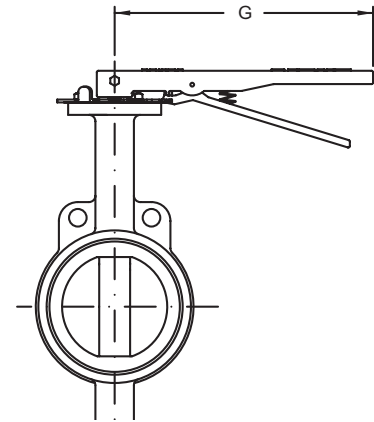

WITH HANDLE

All gear operators supplied with 12" handwheels with gearing to provide rim pull at 50# or less

DIMENSIONS

VALVE SIZE		GEAR RATIO	DIMENSIONS (IN.)						
INCHES	DN		A	B	C	D	E	F	G
2"	50	30:1	3.4	3.0	9.2	11.9	2.5	1.5	10.5
2.5"	65	30:1	3.4	3.0	9.2	11.9	2.5	1.5	10.5
3"	80	30:1	3.4	3.0	9.2	11.9	2.5	1.5	10.5
4"	100	30:1	3.4	3.0	9.2	11.9	2.5	1.5	10.5
5"	125	30:1	3.4	3.0	9.2	11.9	2.5	1.5	10.5
6"	150	30:1	3.4	3.1	8.9	11.9	2.5	1.5	10.5
8"	200	50:1	3.4	3.3	8.9	11.9	3.0	1.6	14.0
10"	250	50:1	3.4	3.3	8.9	11.9	3.0	1.6	14.3
12"	300	50:1	3.4	3.3	8.9	11.9	3.0	1.6	14.3
14"*	350*	50:1	3.4	3.3	8.9	11.9	3.0	1.6	--
16"*	400*	80:1	4.8	5.1	11.8	11.9	4.7	2.3	--
18"*	450*	80:1	4.8	5.1	11.8	11.9	4.7	2.3	--
20"*	500*	300:1	5.9	5.1	13.8	11.9	4.7	2.8	--
24"*	600*	300:1	5.9	5.1	13.8	11.9	4.7	2.8	--
30"*	750*	640:1	4.9	5.1	11.9	15.7	7.8	5.0	--
36"*	900*	640:1	4.9	5.1	11.9	15.7	9.0	5.0	--

* LD141 Series only

BUTTERFLY VALVES



141 / 145 & 149 SERIES

OPERATING TORQUE

All torque valves shown in the chart are for wet (water and other non-lubricating media) on-off service. For dry services (non-lubricating, dry gas media) multiply the values by 1.15. For lubricious services (clean, non-abrasive lubricating media) multiply values by 0.85.

Under certain conditions, hydrodynamic torque can meet or exceed seating and unseating torques. When designing valve systems, hydrodynamic torque must be considered to help ensure correct selection of actuation.

TORQUE RATING (FT./LB.)

VALVE SIZE		FULL RATED PRESSURES (PSIG)			
INCHES	DN	ΔP 50	ΔP 100	ΔP 150	ΔP 200
2	50	100	106	111	117
2.5	65	150	163	176	189
3	80	207	220	232	244
4	100	290	323	357	390
5	125	423	481	540	598
6	150	599	691	783	875
8	200	1060	1183	1307	1430
10	250	1671	1872	2074	2275
12	300	2568	2795	3023	3250
14*	350*	2640	3070	3500	N/A
16*	400*	4260	4880	5500	N/A
18*	450*	6287	7243	8200	N/A
20*	500*	8360	9180	10000	N/A
24*	600*	15427	16813	18200	N/A

* LD141 only

141 / 145 & 149 SERIES

VELOCITY LIMITS

- For ON/OFF Services
- Non-Abrasive Liquids - 30 feet/sec (9m/sec)
- Gases - 175 feet/sec (54m/sec)

141 / 145 & 149 SERIES

CV DATA

Cv values (US gallons per minute) represent the flow of 60°F water through a 100% open valve at a pressure drop of 1 psi. The metric equivalent, Kv, is the flow of water at 16°C through the valve in cubic meters per hour at a pressure drop of 1 kg/cm². To convert Cv to Kv, multiply the Cv by 0.8569.

RATED FLOW COEFFICIENT (CV)

VALVE SIZE		ANGLE OF DISC OPENING (DEGREES)								
INCHES	DN	10°	20°	30°	40°	50°	60°	70°	80°	90°
2	50	0.06	3	7	15	27	44	70	105	115
2.5	65	0.10	6	12	25	45	75	119	178	196
3	80	0.20	9	18	39	70	116	183	275	302
4	100	0.30	17	36	78	139	230	364	546	600
5	125	0.50	29	61	133	237	392	620	930	1022
6	150	0.80	45	95	205	366	605	958	1437	1579
8	200	2	89	188	408	727	1202	1903	2854	3136
10	250	3	151	320	694	1237	2047	3240	4859	5340
12	300	4	234	495	1072	1911	3162	5005	7507	8250
14*	350*	6	338	715	1549	2761	4568	7230	10844	11917
16*	400*	8	464	983	2130	3797	6282	9942	14913	16388
18*	450*	11	615	1302	2822	5028	8320	13168	19752	21705
20*	500*	14	791	1674	3628	6465	10698	16931	25396	27908
24*	600*	22	1222	2587	5605	9989	16528	26157	39236	43116

* LD141 only

This chart should be used as a general guide. For additional Cv information, consult the Engineering and Application Data Section. Cv = the volume of water in U.S. gallons per minute that will pass through a given valve opening with a pressure drop of 1 psig at room temperature.



LD/WD 141 & LD/WD 145 SERIES

LD/WD 141
APOLLO INTERNATIONAL™



**WD 141
WAFER
2" - 12"**



**LD 141
LUG
2" - 24"**

LD/WD 145
MADE IN USA



**WD 145
WAFER
2" - 12"**



**LD 145
LUG
2" - 12"**

The Apollo® LD/WD Series ductile iron butterfly valves are ideal for use in industrial and HVAC/mechanical applications. The WD Series is a wafer style valve and the LD Series is a lug style.

FEATURES

- Compatible with ANSI 125# & 150# Flanges
- ISO 5211 Top Plate Allows Choice of Apollo® Actuators and Manual Operators
- Conforms to MSS SP-67 & API 609
- LD141 and LD145 Series Suitable for End of Line Service to Rated Pressure (2" - 24")
- 3"-24" Meet Performance Requirements of AWWA C-504
- Certified NSF/ANSI 372 Lead Free
- Certified NSF/ANSI 61 Water Quality*
- Registered Under Canadian Registration Number CRN# OC12102.8CL

*Applies to Bronze and Stainless Steel Disc Models

OPTIONS

- 10 Position Handle
- Gear Operator
- Infinite Position Handle
- Locking Handle
- Gear Operator with Chain Wheel
- Locking Gear Operator
- Locking Gear Operator with Chain Wheel
- Pneumatic Actuation
- Electric Actuation
- (-SF) Silicone Free Assembly Option

PRESSURE-TEMPERATURE RATING @ 100° F (37.8° C)

- All Body, Disc, Seat Combinations:
- 2"-12" (DN50 - DN300) 200 psi (13.8 bar)
- 14"-24" (DN350 - DN600) 150 psi (10.3 bar)
- All Sizes - Vacuum Rating: 29 in. Hg

TORQUE RATING (IN./LB.)

VALVE SIZE ¹		FULL RATED PRESSURES (PSIG)			
INCHES	DN	ΔP50	ΔP100	ΔP150	ΔP200
2	50	100	106	111	117
2.5	65	150	163	176	189
3	80	207	220	232	244
4	100	290	323	357	390
5	125	423	481	540	598
6	150	599	691	783	875
8	200	1060	1183	1307	1430
10	250	1671	1872	2074	2275
12	300	2568	2795	3023	3250
14	350	2640	3070	3500	N/A
16	400	4260	4880	5500	N/A
18	450	6287	7243	8200	N/A
20	500	8360	9180	10000	N/A
24	600	15427	16813	18200	N/A

¹ LD (2"-24"); WD (2"-12"); LC (2"-12")
Sizes 28"-48": Contact factory for availability.

Actuation assistance available in Section D, with the Apollo® Actuator Wizard located at actuatorwizard.conbraco.com or by calling customer support at (704)841-6000.

BUTTERFLY VALVES



BUTTERFLY VALVES

LD141 SERIES APOLLO INTERNATIONAL™

New!



BUTTERFLY
VALVES

The large diameter Apollo International™ LD141 Series Ductile Iron Butterfly Valves are ideal for use in Industrial and Commercial/HVAC/Mechanical applications. The LD141 Series is lug style butterfly valve. Available in sizes 28" - 48".

FEATURES

- Compatible with ANSI 125# & 150# Flanges
- ISO 5211 Top Plate Allows Choice of Apollo® Pneumatic Actuators and Gear Operators
- Conforms to MSS SP-67 & API 609
- Suitable for End of Line Service to Rated Pressure

PERFORMANCE RATING

- Pressure Rating: 28" to 48": 150 psi

MATERIAL OPTIONS

Body

- Ductile Iron ASTM A536, (65-45-12)

Seat Material

- EPDM: -20°F to 250°F Intermittent
225°F Continuous
- BUNA-N: 10°F to 180°F

Disc Material

- Aluminum Bronze
- Ductile Iron A536 Nickel Plated
- 316 Stainless Steel, CF8M (Standard)

OPERATOR

- (-0) None
- (-2) Gear Operator (12" Handwheels)
- (-5) Gear Operator w/ Chain Wheel
- (-7) Locking Gear Operator
- (-8) Locking Gear Operator w/ Chain Wheel

STANDARD MATERIAL LIST

BODY	Ductile Iron ASTM A536
BUSHINGS	Bronze
STEM SEAL	Buna-N
SHAFT	416 SS
SEAT	EPDM
	Buna-N (Nitrile)
DISC	Aluminum Bronze
	Ductile Iron / A536 Nickel Plated
	316 Stainless Steel / CF8M (Standard)

DIMENSIONS

SIZE (IN.)	DIMENSIONS (IN.)												WEIGHT (LB.)
	A	B	C	D	ØD1	ØD2	ØD3	ØD4	ØD5	ØD6	N-UNC	N-ØD	
28	25.00	21.18	2.598	6.496	33.99	7.87	10.00	11.81	2.494	36.42	28 - 1-1/4	8-0.709	648
30	26.57	22.05	2.598	6.496	36.00	7.87	10.00	11.81	2.494	38.78	28 - 1-1/4	8-0.709	728
32	26.61	23.66	2.598	7.480	38.50	7.87	10.00	11.81	2.494	41.73	28 - 1-1/2	8-0.709	772
36	30.39	25.79	4.65	7.874	42.75	7.87	10.00	11.81	2.95	46.06	32 - 1-1/2	8-0.709	1162
40	31.30	28.50	5.59	8.50	47.24	7.87	10.00	11.81	3.35	50.79	36 - 1-1/2	8-0.709	1526
42	33.78	30.59	5.91	9.88	49.50	7.87	10.00	11.81	3.74	52.95	36 - 1-1/2	8-0.709	2138
48	37.13	32.48	5.91	10.87	56.00	9.06	11.73	13.78	4.13	59.45	44 - 1-1/2	8-0.866	2686

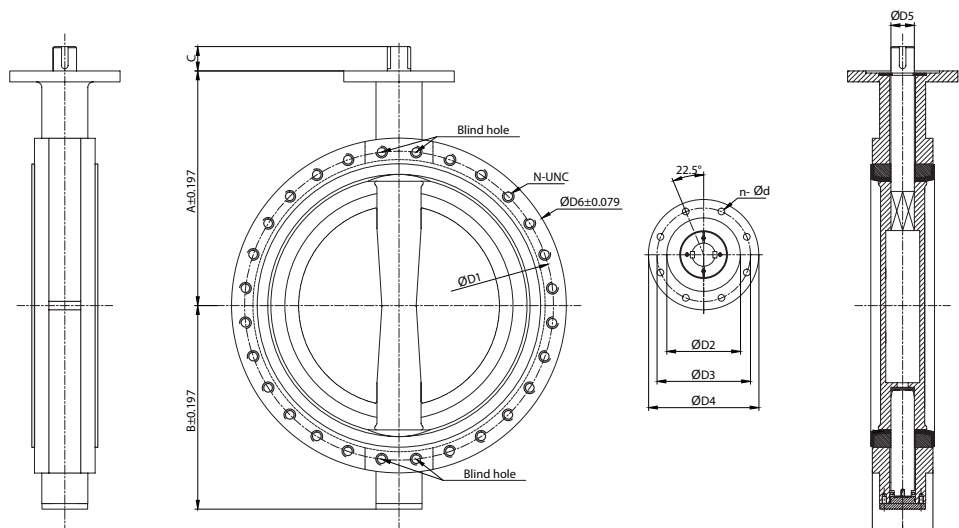



LC149 SERIES

APOLLO INTERNATIONALTM - CONTRACTOR GRADE



The LC149 Series Cast Iron Butterfly Valves are ideal for use in Industrial and HVAC/Mechanical applications. The LC149 Series is a lug style valve designed to be economical yet full featured.

PERFORMANCE RATING

- Max Operating Pressure: 200 psi (13.8 bar)
- Temperature Range: -20°F to 250°F Intermittent, 225°F Continuous

APPROVALS

- NSF/ANSI 372 Lead Free
- NSF/ANSI 61 Water Quality
- Canadian Registration Number CRN# OC12102.8CL

DIMENSIONS - 149 SERIES WITH HANDLE

SIZE (IN.)	DIMENSIONS (IN.)							WEIGHT (LB.)
	A	B	C	D	E	F	G	
2	3.25	6.38	1.25	10.5	3.1	2.70	1.75	8
2-1/2	3.75	6.88	1.25	10.5	3.1	2.70	1.88	10
3	4.00	7.13	1.25	10.5	3.1	2.70	1.88	11
4	4.88	7.88	1.25	10.5	3.1	2.70	2.13	17
5	5.38	8.38	1.25	10.5	3.1	2.70	2.25	20
6	5.88	8.88	1.25	10.5	3.1	2.70	2.25	23
8	7.13	10.25	1.75	14.3	3.5	4.61	2.50	44
10	8.25	11.50	1.88	14.3	3.5	4.61	2.75	67
12	9.75	13.25	1.88	14.3	3.5	4.61	3.13	102

STANDARD MATERIAL LIST

BODY	Cast Iron, ASTM A126 Class B
BUSHINGS	PTFE
STEM SEAL	EPDM
SHAFT	Stainless Steel, ASTM A276, Type 416
SEAT	Black EPDM with Phenolic Backing
DISC	Aluminum Bronze, ASTM B148-C95400

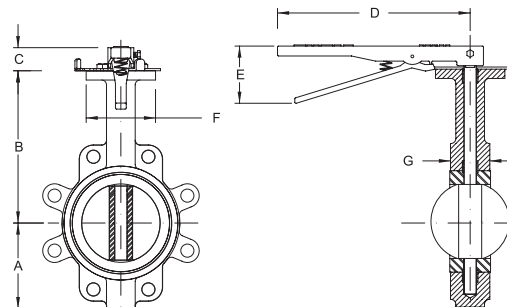

DIMENSIONS - 149 SERIES WITH OPTIONAL GEAR OPERATOR

SIZE (IN.)	DIMENSIONS (IN.)										WEIGHT (LB.)
	A	B	C	D	G	H	J	K	P	ØR	
8	7.13	10.25	3.38	8.00	2.50	1.62	9.48	3.25	1.50	11.88	71
10	8.25	11.50	3.38	8.00	2.75	1.62	9.48	3.25	1.50	11.88	94
12	9.75	13.25	3.38	8.00	3.13	1.62	9.48	3.25	1.50	11.88	129

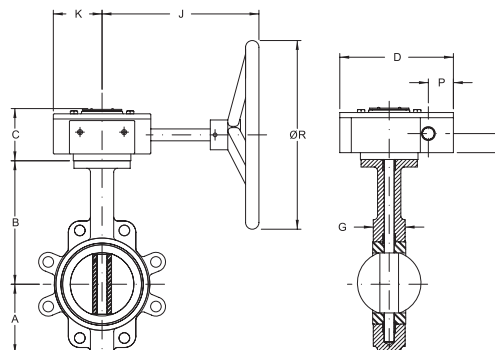



PART NUMBER MATRIX (2" - 24")

LD	141	06	B	E	1	1 -A (LD ONLY)
MODEL	SERIES	SIZE (IN.)	DISC MATERIAL	SEAT MATERIAL	SHAFT	OPERATOR
LD - LUG BODY	141 - APOLLO INTERNATIONAL™ (DUCTILE IRON)	02 - 2"	B - ALUMINUM BRONZE	E - BLACK EPDM	1 - 416 SS	0 - BARE SHAFT
WD - WAFER BODY	145 - ASSEMBLED & TESTED IN USA (DUCTILE IRON)	25 - 2.5"	D - DUCTILE IRON A536	-20° F TO 250° F	(STANDARD)	1 - 10 POSITION HANDLE
		03 - 3"	NICKEL PLATED	-29° C TO 121° C	2 - 316 SS	2 - GEAR OPERATOR - DIRECT MOUNT
		04 - 4"	S - STAINLESS STEEL, CF8M	N - BLACK BUNA-N		3 - INFINITE POSITION HANDLE
		05 - 5"		10° F TO 180° F		4 - LOCKING HANDLE
		06 - 6"		-12° C TO 82° C		5 - GEAR OPERATOR W/ CHAINWHEEL
		08 - 8"		V - BLACK VITON® B†		7 - LOCKING GEAR OPERATOR
		10 - 10"		-20° F TO 300° F		8 - LOCKING GEAR OPERATOR
		12 - 12"		-29° C TO 149° C		W/CHAINWHEEL
		14 - 14"		(145 SERIES ONLY)		-SF - SILICONE FREE ASSEMBLY
	141 - SIZES 14"- 24"	16 - 16"				
		18 - 18"				
	NOTE: LD-141 LUG STYLE ONLY	20 - 20"				
		24 - 24"				

Certification - Product complies with NSF/ANSI 372 and NSF/ANSI 61 lead content requirements.
 *NSF 61 does not apply to ductile iron disc
 †Viton is primarily used for process applications, and has not been included in the scope of our Lead Free approvals

EXAMPLE:
 WD141-06-BE-11 = 6" WD141 Series, Ductile Iron Wafer Body, Aluminum Bronze Disc, Black EPDM Seat, 416 SS Shaft with 10 Position Handle

PART NUMBER MATRIX (28" - 48")

WD	141	06	B	E	1	2
MODEL	SERIES	SIZE (IN.)	DISC MATERIAL	SEAT MATERIAL	SHAFT	OPERATOR
LD - LUG BODY	141 - APOLLO INTERNATIONAL™ (DUCTILE IRON)	28 - 28"	B - ALUMINUM BRONZE	E - BLACK EPDM	1 - 416 SS	0 - BARE SHAFT
		30 - 30"	D - DUCTILE IRON A536	-20° F TO 250° F	(STANDARD)	2 - GEAR OPERATOR - DIRECT MOUNT
		32 - 32"	NICKEL PLATED	-29° C TO 121° C	2 - 316 SS	5 - GEAR OPERATOR W/ CHAINWHEEL
		36 - 36"	S - STAINLESS STEEL, CF8M	N - BLACK BUNA-N		7 - LOCKING GEAR OPERATOR
		40 - 40"	(STANDARD)	10° F TO 180° F		8 - LOCKING GEAR OPERATOR
		42 - 42"		-12° C TO 82° C		W/CHAINWHEEL
		48 - 48"				

PART NUMBER MATRIX

LC149	06	2
SERIES	SIZE (IN.)	OPERATOR
LC149 - CAST IRON LUG BODY	02 - 2"	1 - 10 POSITION HANDLE (2" - 12")
ALUMINUM BRONZE DISC	25 - 2.5"	2 - GEAR OPERATOR (8" - 12" ONLY)
416 SS SHAFT	03 - 3"	
BLACK EPDM SEAT	04 - 4"	
	05 - 5"	
	06 - 6"	
	08 - 8"	
	10 - 10"	
	12 - 12"	

EXAMPLE:
 LC149-06-1: 6" LC149 Series, Cast Iron Body, Aluminum Bronze Disc, Black EPDM Seat, 416 SS Shaft with 10 Position Handle

Certification - Product complies with NSF/ANSI 372 and NSF/ANSI 61 lead content requirements.
 †Viton is primarily used for process applications, and has not been included in the scope of our Lead Free approvals



PRICING

Pricing of valves and options may be accessed through published price list CPPL9000 or by authorized Apollo® Online users.



The Apollo® LD/WD Series Ductile Iron Butterfly Valves offer reliable performance in a wide range of applications; on/off, throttling, control isolation, flow balancing and diversion. Ideal for use in Industrial and HVAC/Mechanical applications.

Service compatibility is dependant on several factors; the corrosion resistance of the disc and shaft and the chemical resistance of the seat (liner) and required temperature range. Erosion resistance also affects material selection when dealing with abrasive slurries.

EPDM CARTRIDGE STYLE SEAT ETHYLENE PROPYLENE RUBBER	BUNA-N CARTRIDGE STYLE SEAT NITRILE RUBBER ALSO KNOWN AS NBR	VITON® B CARTRIDGE STYLE SEAT FLUOROCARBON RUBBER
TEMPERATURE RATED FROM -20°F TO 250°F INTERMITTENT 225°F CONTINUOUS	TEMPERATURE RATED FROM 10°F TO 180°F	TEMPERATURE RATED FROM -20°F TO 300°F
TYPICAL APPLICATIONS: <ul style="list-style-type: none"> • Typically offered for general service and elevated temperatures • Hot water • Chilled water • Glycols • Detergents • Phosphate esters • Ketones • Alcohols • Low Pressure Steam • Dilute acids • Phosphate based hydraulic oils and fluids • Silicone greases and oils • Alkalies 	TYPICAL APPLICATIONS: <ul style="list-style-type: none"> • Good for most general services • Water – ambient temperature • Vacuum • Compressed air • Salt solutions • Alkaline solutions • Dilute acids • Petroleum oils & fluids • Silicone oils & greases • Ethylene glycol 	TYPICAL APPLICATIONS: <ul style="list-style-type: none"> • A fluorocarbon rubber with a wide spectrum of chemical resistance (exceptional resistance to oils and chemicals at higher temperatures). • A fluorocarbon rubber that typically has better chemical resistance than Buna-N. • Hydrocarbons • Mineral acids • Alcohols
<div style="text-align: center;"></div> <ul style="list-style-type: none"> • EPDM is not recommended for any hydrocarbon-based oils, petroleum oils, hydrocarbon-based lubricants, or di-ester based lubricants, or air systems with hydrocarbons. 	<div style="text-align: center;"></div> <ul style="list-style-type: none"> • Buna-N can swell in hot water applications, and increase operating torque. • Buna-N is NOT recommended for strong oxidizing agents, nitrated hydrocarbons, Aromatic hydrocarbons (benzene, toluene, xylene), acetates, phenols, aldehydes, gasolines with additives, Automotive brake fluid, Halogen derivatives (carbon tetrachloride, trichloroethylene), Ketones (MEK, acetone), Phosphate ester hydraulic fluids (Skydrol®, Pydraul®), strong acids, ozone. 	<div style="text-align: center;"></div> <ul style="list-style-type: none"> • Viton® can swell in higher temperature water applications. • At low temperatures, Viton's flexibility decreases (hardens), which often increases operating torque. • Viton® is not recommended for ketones, Skydrol fluids, amines, anhydrous ammonia, low molecular weight esters and ethers, hot hydrofluoric chlorosulfonic acids.

BUTTERFLY VALVES



215 / 230 & 260 SERIES

DOUBLE OFFSET HIGH PERFORMANCE

Apollo International™ 215, 230, 260 Series double offset high performance butterfly valves are available in wafer or lug body design. Stainless steel valves are certified lead-free with stainless steel disc and 17-4PH stainless steel stem.

FEATURES

- 215 Series Class 150# Carbon Steel (CWP 285) and 316 SS (CWP 275) 2" to 36"
- 230 Series Class 300# Carbon Steel (CWP 740) and 316 SS (CWP 720) 2" - 24"
- 260 Series Class 600# Carbon Steel (CWP 1480) and 316 SS (CWP 1440) 3"- 12"
- ISO 5211 mounting flange allows choice of Apollo® actuators and manual operators
- Multi-bolt retainer holds and supports the seat. Standard valves are suitable for bi-directional dead-end service at the full pressure-temperature rating of the valve. Same materi;
- Well-suited for a wide range of liquid and steam applications, defined in the high performance butterfly valve pressure-temperature charts
- Vacuum service to 29" Hg
- Soft seats made from TFM 1700
- UHMWPE available on request



APPROVALS AND CERTIFICATIONS

- NSF/ANSI 61 Water Quality and NSF/ANSI 372 Lead Free 2" - 24", 215 & 230 Series
316/CF8M Stainless Steel | 317 Stainless Steel
Duplex Stainless Steel | Super Duplex Stainless Steel
- Registered under Canadian Registration Number CRN# OC17459.CL
- CE marking and documented valves that conform to the European Pressure Equipment Directive (PED) 2014/68/EU are available in ANSI Class 150/300/600 including soft, fire safe and metal seat configurations (sizes 2"-24" only)

STANDARDS COMPLIANCE

- | | |
|-------------------------|---|
| • ASME B16.10 | "Face to Face and End to End Dimensions of Valves" |
| • ASME B16.34 | "Valves - Flanged, Threaded, and Welding End" |
| • ASME B16.5 | "Pipe Flanges and Flanged Fittings" |
| • ANSI/FCI 70-2 | "For Control Valve Seat Leakage" |
| • MSS SP-25 | "Standard Marking System for Valves" |
| • MSS SP-44 | "Steel Pipe Line Flanges" |
| • MSS SP-55 | "Quality Standards for Steel Castings" |
| • MSS SP-61 | "Pressure Testing of Steel Valves" |
| • MSS SP-68 | "High Pressure Butterfly Valves with Offset Design" |
| • API 598 | American Petroleum Institute - "Valve Inspection and Testing" |
| • API 607 - 6th edition | American Petroleum Institute - "Fire Test for Soft Seated Valves" |
| • API 609 | American Petroleum Institute - "Butterfly Valves: Double Flanged, Lug and Wafer Type" |
| • NSF/ANSI 61 | "Drinking Water System Components - Health Effects" (2" - 24", Stainless 215 & 230) |
| • NSF/ANSI 372 | "Drinking Water System Components - Lead Content" (2" - 24", Stainless 215 & 230) |

SERVICES

VACUUM SERVICE

- Standard Apollo® high performance butterfly valves are rated for 29" Hg vacuum

STEAM SERVICE

- The Apollo® high performance butterfly valve is well-suited for a wide range of steam applications. The application range is defined in the high performance butterfly valve pressure-temperature charts



215 / 230 & 260 SERIES ADVANTAGES

ISO 5211 MOUNTING FLANGE

Universal mounting dimensions simplify valve actuation. Allows for direct mounting of several actuators.

ROCKER PACKING GLAND

Shaped packing gland compensates for uneven adjustment of gland nuts.

STEM PACKING

V-ring PTFE, UHMWPE or flat graphite provides positive sealing.

EXTENDED NECK

Allows for 2" of pipe insulation.

BODY

Robust one-piece casting in WCB carbon steel or CF8M stainless steel. Available in wafer & lug style.

POSITIVE CAST DISC STOP

Prevents seat damage from over-travel of the disc beyond the closed position. (not visible)

JACKING TAPS

Allows the use of seat retainer bolts to aid in retainer removal.

SEAT RETAINER

Reliable multi-bolt retainer holds and supports the seat. Standard valves are suitable for bi-directional dead-end service at the full pressure-temperature rating of the valve. Same material as body material.

CORROSION PROTECTION

Polyamide epoxy primer with high performance polyurethane topcoat is the standard finish for carbon steel valve bodies.

STEM

(BLOWOUT PROOF)

17-4 PH stainless steel stem with high strength, and good corrosion resistance. Designed per API 609 standard.

ANTI-EXTRUSION RING

(UNDER STEM SEALS)

Prevents the extrusion of stem seals, maintaining optimum seal.

BEARING

(UPPER)

Full length provides maximum stem support. Made of 316 SS/PTFE

SEAT

An advanced free floating, pressure assisted, solid seat design provides an interference and pressure assisted seal. This creates a positive seal under both low and high pressure requirements. The seat does not rely on any secondary components to hold it in place, assuring longer service life with less maintenance.

TANGENTIAL DISC PINS

17-4 PH stainless steel disc pins are tangentially positioned, placing them in compression rather than shear. This robust joint design eliminates potential failure of the disc-stem connection.

DISC

Standard material is 316 stainless steel.

BEARING

(LOWER)

Full length provides maximum stem support. Made of 316 SS/PTFE

THRUST RING

Centers the disc. Ensures tight shutoff and long service life. Made of 316 SS.

END CAP SEAL

Made of PTFE, UHMWPE or graphite.



215 / 230 & 260 SERIES
HOW TO SPECIFY

BUTTERFLY VALVES

2	15	L	06	C	S	P	8T	A	0	
VALVE TYPE	CLASS	VALVE STYLE	SIZE	BODY MATERIAL	DISC MATERIAL	STEM & PIN MATERIAL	SEAT MATERIAL	SPECIAL SERVICE	OPERATOR	
2 - DOUBLE OFFSET	15 (150)	L - LUG	02 (2")	CARBON STEEL	STAINLESS STEEL	P - 17-4 PH SS	8T - RTFM (TFM 1700 W/GLASS)	A - STANDARD APOLLO	0 - BARE STEM	
	30 (300)	W - WAFER	25 (2.5")	C - A216 WCB	S - A351 CF8M (316 SS)				1 - LEVER OPERATOR ⁴	
	60 (600) ¹		03 (3")						2 - WORM GEAR OPERATOR	
				04 (4")			A - ALLOY 20	2F - TFM/INCONEL, GRAPHITE SEALS (FIRE SAFE)		
				05 (5")	STAINLESS STEEL	A - A351 CN7M (ALLOY 20)	B - 317 SS			5 - WORM GEAR OPERATOR W/ CHAIN WHEEL
				06 (6")	S - A351 CF8M (316 SS)		H - HASTELLOY* C			
				08 (8")		B - A351 CG8M (317 SS)	J - DUPLEX		2M - 316SS (METAL SEATED)	7 - LOCKING WORM GEAR OPERATOR
				10 (10")			K - SUPER DUPLEX			
				12 (12")	A - A351 CN7M (ALLOY 20)	J - A995 CD3MN (2205 DUPLEX)	M - MONEL*			
				14 (14")						
				16 (16")	B - A351 CG8M (317 SS)	K - A995 CD3MWCUN (2507 SUPER DUPLEX)	S - 316 SS			8 - LOCKING WORM GEAR OPERATOR W/ CHAIN WHEEL
				18 (18")						
				20 (20")	J - A995 CD3MN (2205 DUPLEX)					
				24 (24")						
				30 (30") ²	K - A995 CD3MWCUN (2507 SUPER DUPLEX)	NICKEL ALLOYS				
				36 (36") ²		H - A494 CW12MW (HASTELLOY* C)				
					M - A494 M-35-1 (MONEL*)					
				NICKEL ALLOYS						
				H - A494 CW12MW (HASTELLOY* C)						
				M - A494 M-35-1 (MONEL*)						

EXAMPLE:
215L06CSP8TA0 = 6" Class 150 Lug, Carbon Steel Body, SS Disc, 17-4 PH Stem, TFM 1700 Seats, Standard Service, Bare Stem

() Represents close wrought equivalent
 1 Class 600 valves available in sizes 3" through 12" (excluding 5" size)
 2 215L Only
 3 UHMWPE not available in Class 600
 4 Standard handle can be locked in the full open or fully closed position.
 Lever operators are available with 2"-12" class 150 valves (215), and 2"-10" class 300 valves (230)
 See table for Lever Handle Availability & Maximum Differential Pressure

Safety Warning:

Gear operators are normally specified for larger high performance butterfly valves because the force of the pipeline flow on the disc can be too great to safely use a handle.

LEVER HANDLE AVAILABILITY & MAXIMUM DIFFERENTIAL PRESSURE

		SOFT SEAT (CODES: 8T & 21)		FIRE-SAFE SEAT (CODE: 2F)		METAL SEAT (CODE: 2M)	
		PSI	BAR	PSI	BAR	PSI	BAR
Class 150	215	2"-6"		Full Rating		Full Rating	
		8"		150	10.3	Not Available	
		10"-12"		50	3.4	Not Available	
Class 300	230	2"-4"		Full Rating		Full Rating	
		6"-8"		150	10.3	Not Available	
		10"		50	3.4	Not Available	



215 / 230 & 260 SERIES

RESILIENT SEAT

CLASS 150 - 2" THRU 24", 30", 36" | CLASS 300 - 2" THRU 24" | CLASS 600 - 3" THRU 12"

STANDARD MATERIAL LIST

	PART	MATERIAL
1	Body	A351-CF8M or A216-WCB
2	Disc	A351-CF8M
3	Seat	RTFM (TFM 1700)*
4	Seat Retainer	A351-CF8M or A216-WCB
5	Seat Retainer Bolt	Stainless Steel 316
6	Stem	17-4PH
7	Disc Pin	17-4PH
8	End Cap Bolt	Stainless Steel 316
9	Washer	Stainless Steel 316
10	End Cap	A351-CF8M or A216-WCB
11	Spacer	PTFE
12	End Cap Seal	PTFE
13	Thrust Ring	Stainless Steel 316
14	Lower Bearing	Stainless Steel 316/PTFE
15	Upper Bearing	Stainless Steel 316/PTFE
16	Anti-Extrusion Ring	Stainless Steel 316
17	Stem Packing	PTFE
18	Packing Gland	Stainless Steel 316
19	Gland Nut	Stainless Steel 316
20	Washer	Stainless Steel 316
21	Disc Spring	Stainless Steel 304
22	Disc Spring Retainer	Stainless Steel 316
23	Gland Studs	Stainless Steel 316
24	Gland Plate	A351-CF8M or A216-WCB

* TFM 1700 modified PTFE is a next-generation PTFE with improved properties. Added glass further improves the seat providing greater wear resistance and a higher modulus.

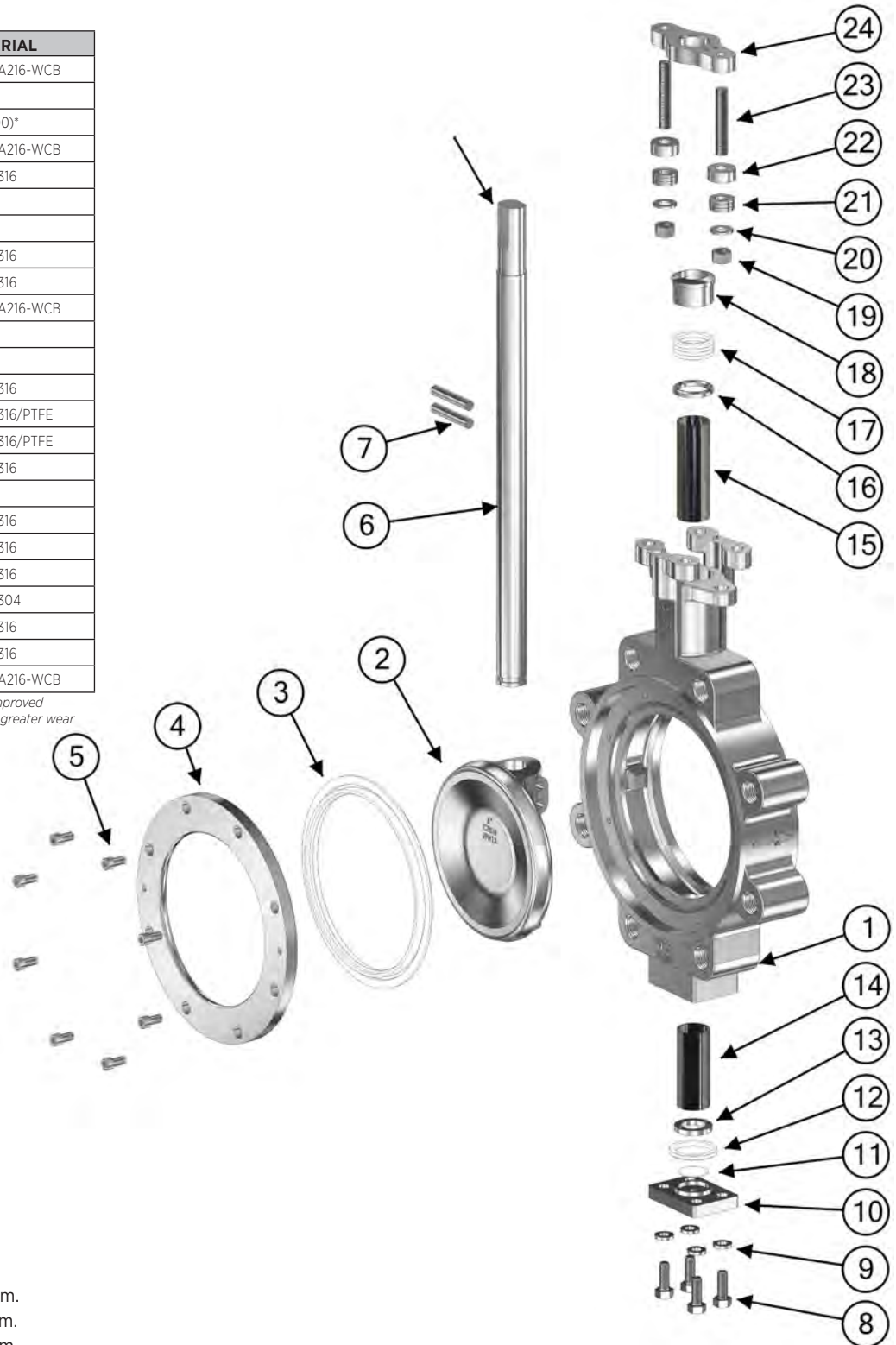

BUTTERFLY VALVES

EXPLODED VIEW
LUG DESIGN SHOWN

NOTE

- Class 150 Size 10" & larger have keyed stem.
- Class 300 Size 8" & larger have keyed stem.
- Class 600 Size 6" & larger have keyed stem.



215 / 230 & 260 SERIES

FIRE SAFE SEAT

CLASS 150 - 2" THRU 24" | CLASS 300 - 2" THRU 24" | CLASS 600 - 3" THRU 12"

STANDARD MATERIAL LIST

	PART	MATERIAL
1	Body	A351-CF8M or A216-WCB
2	Disc	A351-CF8M
3	Body Seal	Graphite
4	Metal Seat	Inconel 718
5	Seat	RTFM (TFM 1700)*
6	Seat Retainer	A351-CF8M or A216-WCB
7	Seat Retainer Bolt	Stainless Steel 316
8	Stem	17-4PH
9	Disc Pin	17-4PH
10	End Cap Bolt	Stainless Steel 316
11	Washer	Stainless Steel 316
12	End Cap	A351-CF8M or A216-WCB
13	Spacer	Stainless Steel 316
14	End Cap Seal	Graphite
15	Thrust Ring	Stainless Steel 316
16	Lower Bearing	Stainless Steel 316/PTFE
17	Upper Bearing	Stainless Steel 316/PTFE
18	Anti-Extrusion Ring	Stainless Steel 316
19	Stem Packing	Graphite
20	Packing Gland	Stainless Steel 316
21	Gland Nut	Stainless Steel 316
22	Washer	Stainless Steel 316
23	Disc Spring	Stainless Steel 304
24	Disc Spring Retainer	Stainless Steel 316
25	Gland Studs	Stainless Steel 316
26	Gland Plate	A351-CF8M or A216-WCB

* TFM 1700 modified PTFE is a next-generation PTFE with improved properties. Added glass further improves the seat providing greater wear resistance and a higher modulus.

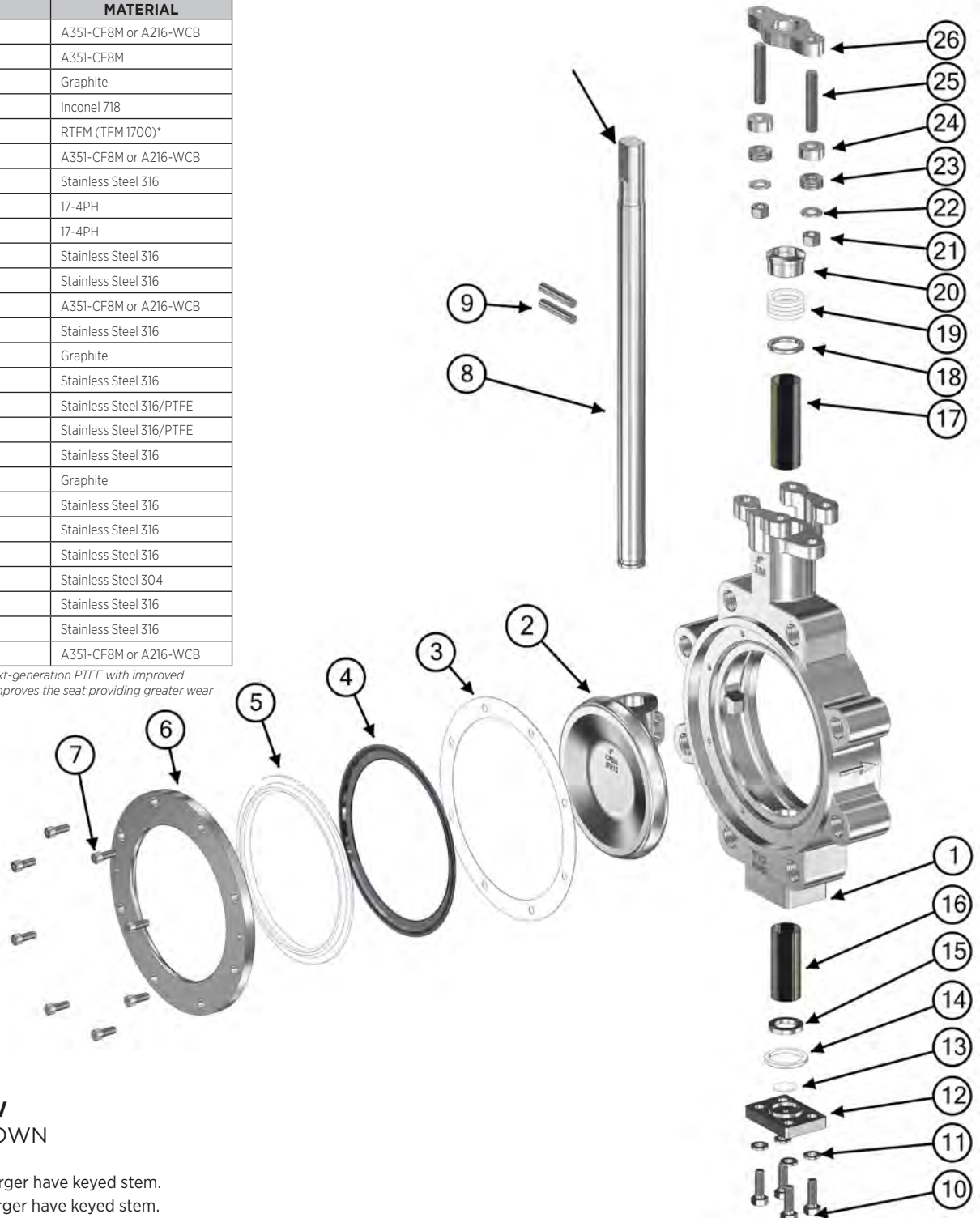

EXPLODED VIEW

LUG DESIGN SHOWN

NOTE

- Class 150 Size 10" & larger have keyed stem.
- Class 300 Size 8" & larger have keyed stem.
- Class 600 Size 6" & larger have keyed stem.



215 / 230 & 260 SERIES

METAL SEAT

CLASS 150 - 2" THRU 24" | CLASS 300 - 2" THRU 24" | CLASS 600 - 3" THRU 12"

STANDARD MATERIAL LIST

	PART	MATERIAL
1	Body	A351-CF8M or A216-WCB
2	Disc	A351-CF8M - Nitrided
3	Body Seal	Synthetic Gasket
4	Seat	Stainless Steel 316 - Nitrided
5	Seat Retainer	A351-CF8M or A216-WCB
6	Seat Retainer Bolts	Stainless Steel 316
7	Stem	17-4 PH
8	Disc Pin	17-4 PH
9	End Cap Bolt	Stainless Steel 316
10	Washer	Stainless Steel 316
11	End Cap	A351-CF8M or A216-WCB
12	Spacer	Graphite
13	End Cap Seal	Graphite
14	Thrust Ring	Stainless Steel 316
15	Lower Bearing	Stainless Steel 316 / PTFE
16	Upper Bearing	Stainless Steel 316 / PTFE
17	Anti-Extrusion Ring	Stainless Steel
18	Stem Packing	Graphite
19	Packing Gland	Stainless Steel 316
20	Gland Nut	Stainless Steel 316
21	Washer	Stainless Steel 316
22	Gland Studs	Stainless Steel 316
23	Gland Plate	A351-CF8M or A216-WCB

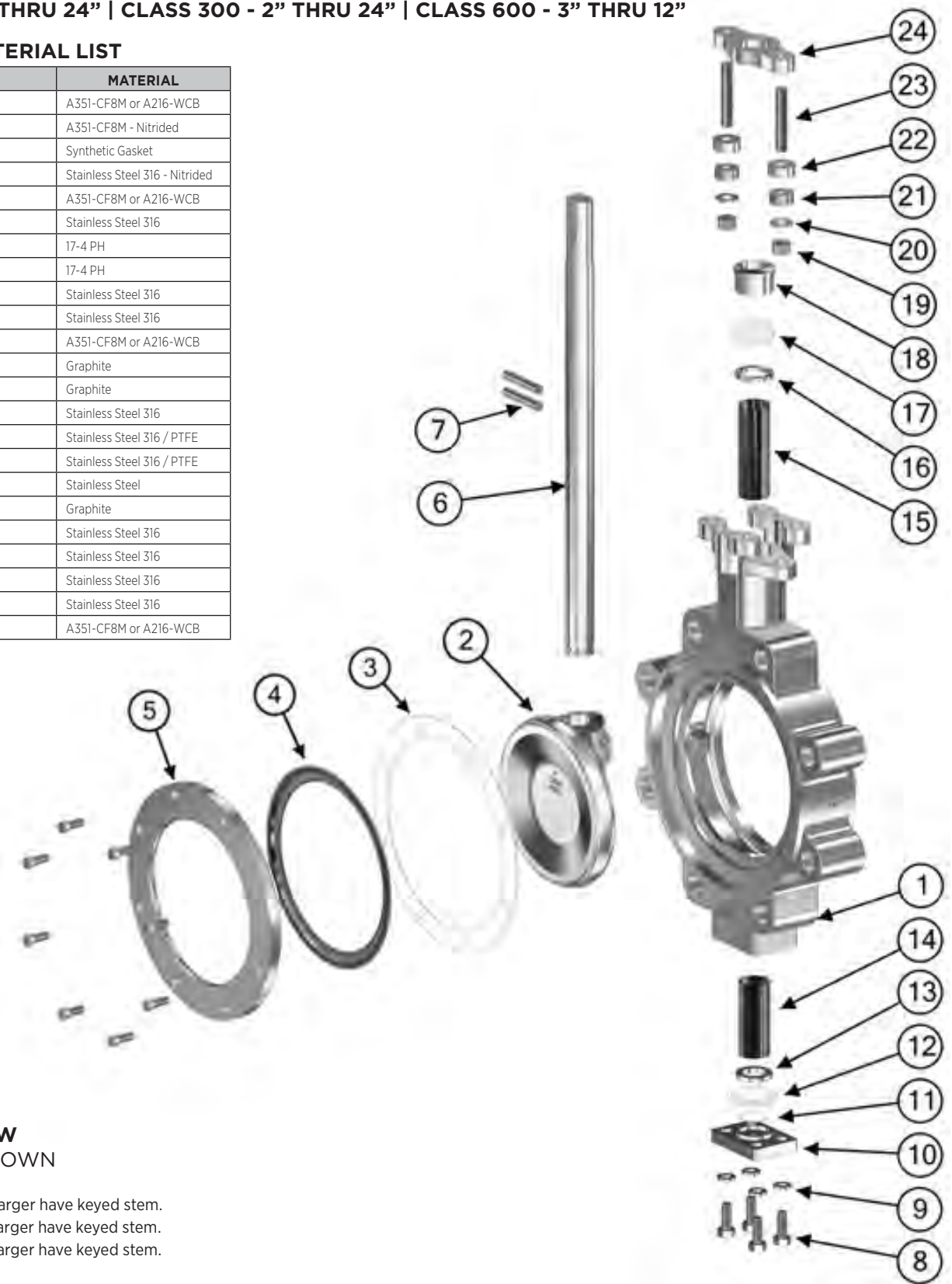

BUTTERFLY VALVES

EXPLODED VIEW
LUG DESIGN SHOWN

NOTE

- Class 150 Size 10" & larger have keyed stem.
- Class 300 Size 8" & larger have keyed stem.
- Class 600 Size 6" & larger have keyed stem.

215L/215W SERIES
CLASS 150 - 2" THRU 36"

Four hole mounting pattern shown.
See table column "G" for number of mounting holes.

BUTTERFLY VALVES

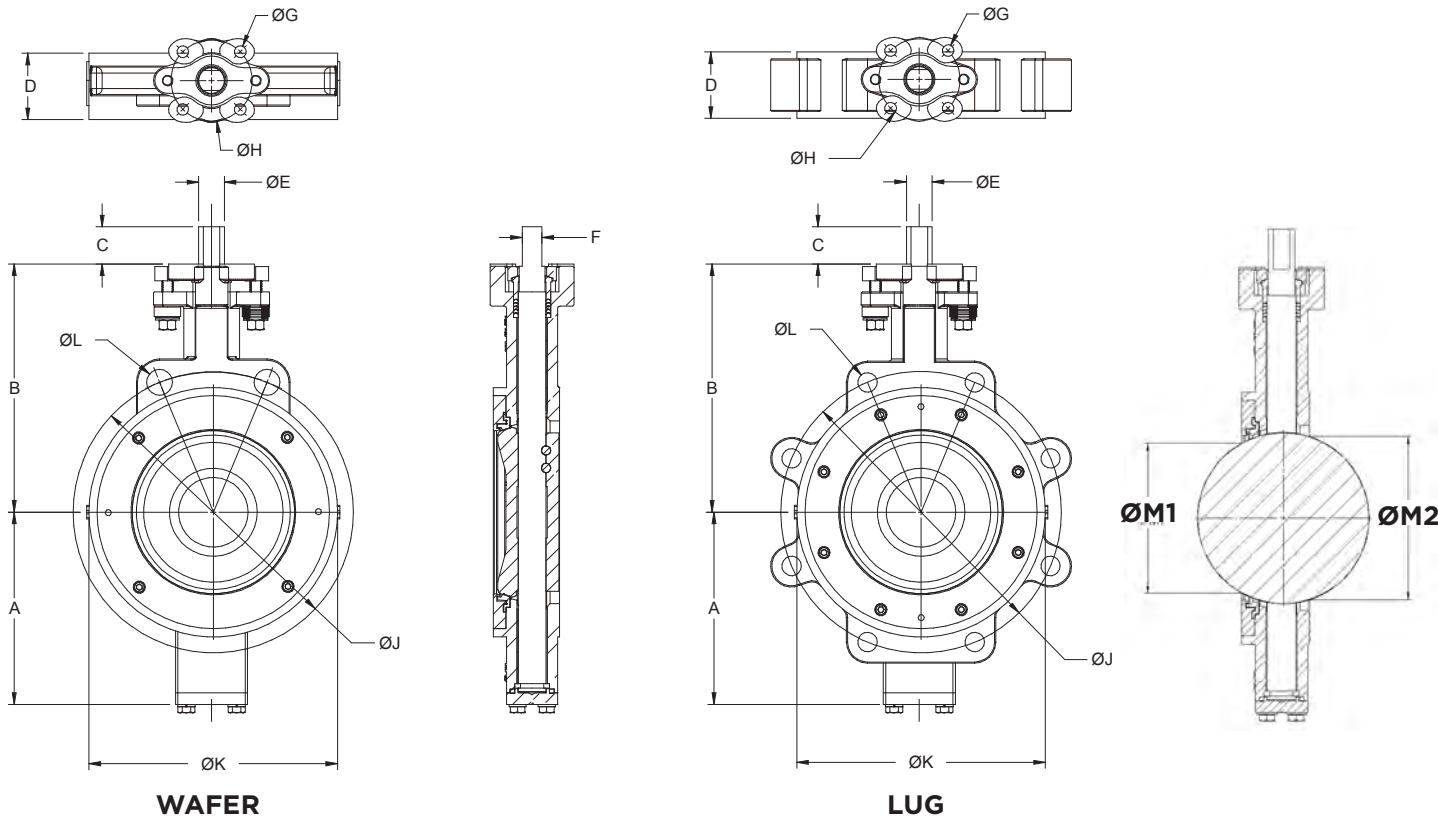

150 CLASS
DOUBLE-D AND KEYED STEM

SIZE (IN.)	SIZE DN	DIMENSIONS (IN.)														
		A	B	C	D	ØE	F	KEY	ØG	ØH**	ØJ	ØK	ØL WAFER	ØL LUG	ØM1	ØM2
2	50	3.622	5.276	1.102	1.693	0.476	0.354	--	4 x 0.394	2.756 (F07)	4.75	4.09	2 x 0.669	4 x 5/8"-11UNC-2B	0.50	1.64
2.5	65	4.016	5.787	1.102	1.850	0.555	0.433	--	4 x 0.394	2.756 (F07)	5.50	4.72	2 x 0.748	4 x 5/8"-11UNC-2B	1.48	2.06
3	80	4.331	6.142	1.102	1.890	0.555	0.433	--	4 x 0.394	2.756 (F07)	6.00	4.92	2 x 0.748	4 x 5/8"-11UNC-2B	1.67	2.58
4	100	4.764	7.008	1.260	2.126	0.713	0.551	--	4 x 0.394	2.756 (F07)	7.50	6.10	2 x 0.748	8 x 5/8"-11UNC-2B	2.76	3.46
5	125	5.591	7.598	1.260	2.244	0.874	0.669	--	4 x 0.394	2.756 (F07)	8.50	7.24	2 x 0.874	8 x 3/4"-10UNC-2B	3.94	4.49
6	150	6.496	8.386	1.259	2.244	0.874	0.669	--	4 x 0.394	2.756 (F07)	9.50	8.43	2 x 0.874	8 x 3/4"-10UNC-2B	5.02	5.46
8	200	7.165	9.449	1.260	2.520	0.992	0.748	--	4 x 0.551	4.921 (F12)	11.75	10.55	2 x 0.874	8 x 3/4"-10UNC-2B	6.95	7.26
10	250	8.386	10.827	2.165	2.795	1.102	--	0.313	4 x 0.551	4.921 (F12)	14.25	12.68	2 x 0.984	12 x 7/8"-9UNC-2B	8.85	9.15
12	300	10.236	12.283	2.165	3.189	1.417	--	0.375	4 x 0.551	4.921 (F12)	17.00	14.92	2 x 0.984	12 x 7/8"-9UNC-2B	10.37	10.70
14	350	11.811	13.307	2.559	3.622	1.654	--	0.437	4 x 0.709	5.512 (F14)	18.75	16.14	2 x 1.118	12 x 1"-8UNC-2B	11.89	12.25
16	400	13.307	15.354	3.150	4.016	1.969	--	0.500	4 x 0.866	6.496 (F16)	21.25	18.43	2 x 1.118	16 x 1"-8UNC-2B	13.59	13.94
18	450	14.803	16.732	3.149	4.488	1.969	--	0.500	4 x 0.866	6.496 (F16)	22.75	20.94	4 x 1.240	16 x 1-1/8"-8UN-2B	15.65	15.91
20	500	15.748	17.717	4.331	5.000	2.362	--	0.625	4 x 0.866	6.496 (F16)	25.00	22.99	4 x 1-1/8"-8UN-2B	20 x 1-1/8"-8UN-2B	17.50	17.72
24	600	18.622	20.787	4.331	6.063	2.559	--	0.750	8 x 0.748	10.000 (F25)	29.50	27.24	4 x 1-1/4"-8UN-2B	20 x 1-1/4"-8UN-2B	20.94	21.01
*30	750	23.228	25.315	4.331	7.480	3.150	--	0.875	8 x 0.748	10.000 (F25)	36.00	36.42	--	28 x 1-1/4"-8UN-2B	26.22	26.28
*36	850	26.575	28.740	4.331	7.992	3.150	--	0.875	8 x 0.906	11.732 (F30)	42.75	45.28	--	32 x 1-1/2"-8UN-2B	32.29	32.35

*30" & 36" are Class 150 Lug Style only.
** ISO 5211 mounting/drilling pattern (F size) shown in parentheses.



230L/230W SERIES
CLASS 300 - 2" THRU 24"

Four hole mounting pattern shown.
See table column "G" for number of mounting holes.

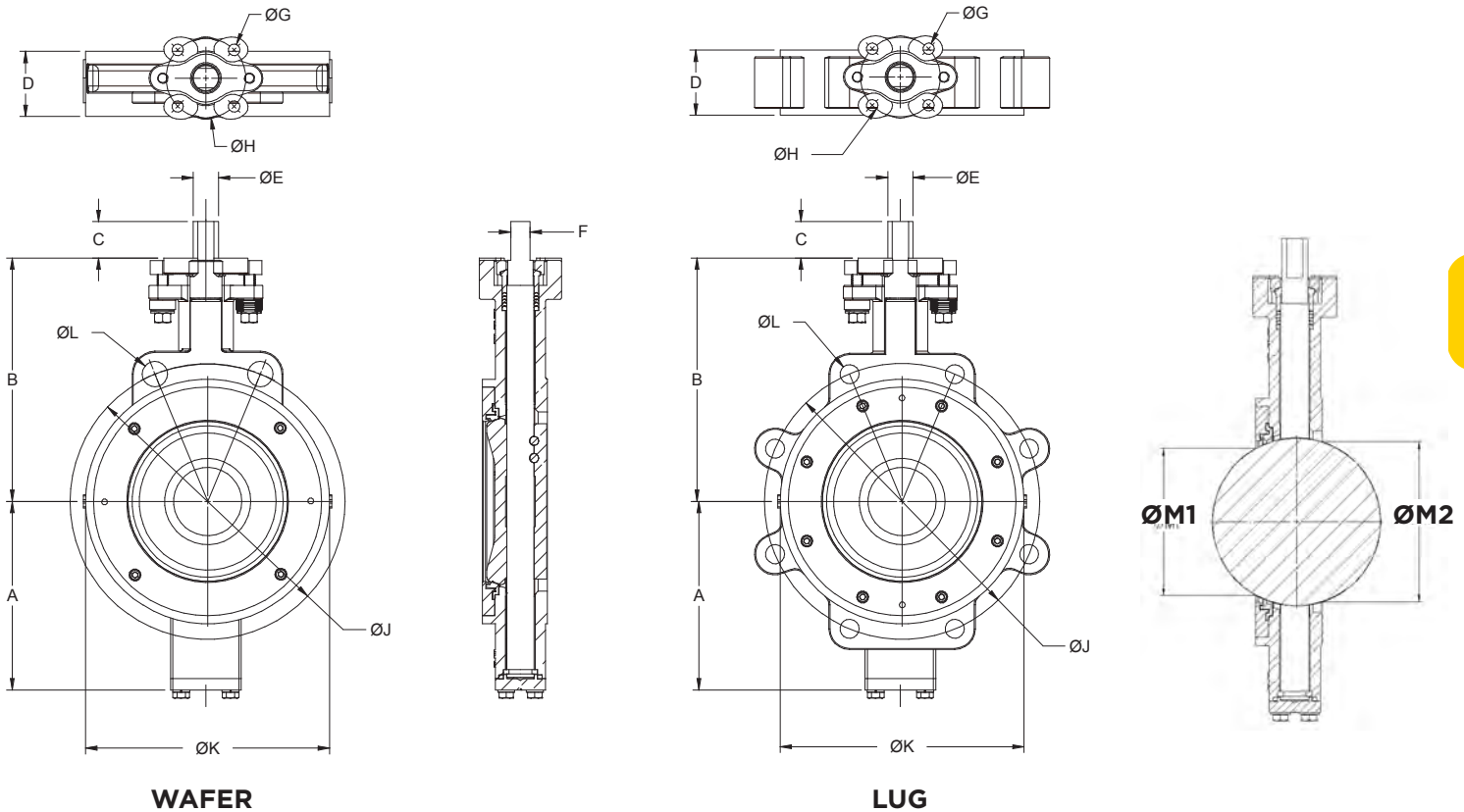

BUTTERFLY VALVES

300 CLASS
DOUBLE-D AND KEYED STEM

SIZE (IN.)	SIZE DN	DIMENSIONS (IN.)														
		A	B	C	D	ØE	F	KEY	ØG	ØH**	ØJ	ØK	ØL WAFER	ØL LUG	ØM1	ØM2
2	50	3.622	5.276	1.102	1.693	0.476	0.354	--	4 x 0.394	2.756 (F07)	5.00	4.17	2 x 0.709	8 x 5/8"-11 UNC-2B	0.50	1.64
2.5	65	4.016	5.787	1.102	1.850	0.555	0.433	--	4 x 0.394	2.756 (F07)	5.88	4.72	2 x 0.874	8 x 3/4"-10 UNC-2B	1.48	2.06
3	80	4.331	6.142	1.102	1.890	0.555	0.433	--	4 x 0.394	2.756 (F07)	6.62	4.92	2 x 0.874	8 x 3/4"-10 UNC-2B	1.67	2.58
4	100	4.764	7.008	1.260	2.126	0.713	0.551	--	4 x 0.394	2.756 (F07)	7.88	6.10	2 x 0.874	8 x 3/4"-10 UNC-2B	2.76	3.46
5	125	5.591	7.598	1.260	2.244	0.874	0.669	--	4 x 0.472	4.016 (F10)	9.25	7.24	2 x 0.874	8 x 3/4"-10 UNC-2B	3.94	4.49
6	150	6.496	8.386	1.259	2.323	0.874	0.669	--	4 x 0.472	4.016 (F10)	10.62	8.43	2 x 0.874	12 x 3/4"-10 UNC-2B	4.93	5.46
8	200	8.268	10.157	2.165	2.874	1.102	--	0.313	4 x 0.551	4.921 (F12)	13.00	10.55	2 x 0.984	12 x 7/8"-9 UNC-2B	6.73	7.19
10	250	9.449	11.417	2.165	3.268	1.417	--	0.375	4 x 0.551	4.921 (F12)	15.25	12.72	4 x 1"-8UNC-2B	16 x 1"-8 UNC-2B	8.44	8.85
12	300	10.63	12.795	2.559	3.662	1.654	--	0.437	4 x 0.709	5.512 (F14)	17.75	15.04	4 x 1-1/8"-8UN-2B	16 x 1-1/8"-8 UN-2B	10.17	10.62
14	350	12.756	14.764	3.150	4.606	1.969	--	0.500	4 x 0.866	6.496 (F16)	20.25	16.14	4 x 1-1/8"-8UN-2B	20 x 1-1/8"-8 UN-2B	11.55	11.89
16	400	14.37	16.732	3.149	5.236	1.969	--	0.500	4 x 0.866	6.496 (F16)	22.50	18.43	4 x 1-1/4"-8UN-2B	20 x 1-1/4"-8 UN-2B	13.21	13.55
18	450	16.043	18.209	4.331	5.866	2.362	--	0.625	8 x 0.748	10.000 (F25)	24.75	20.94	4 x 1-1/4"-8UN-2B	24 x 1-1/4"-8 UN-2B	15.36	15.54
20	500	17.795	19.882	4.331	6.260	2.835	--	0.750	8 x 0.748	10.000 (F25)	27.00	22.99	4 x 1-1/4"-8UN-2B	24 x 1-1/4"-8 UN-2B	16.93	17.27
24	600	20.315	22.835	4.331	7.126	3.150	--	0.875	8 x 0.748	10.000 (F25)	32.00	27.24	4 x 1-1/2"-8UN-2B	24 x 1-1/2"-8 UN-2B	20.57	20.57

** ISO 5211 mounting/drilling pattern (F size) shown in parentheses.



260L/260W SERIES
CLASS 600 - 3" THRU 12"

Four hole mounting pattern shown.
 See table column "G" for number of mounting holes.

BUTTERFLY VALVES

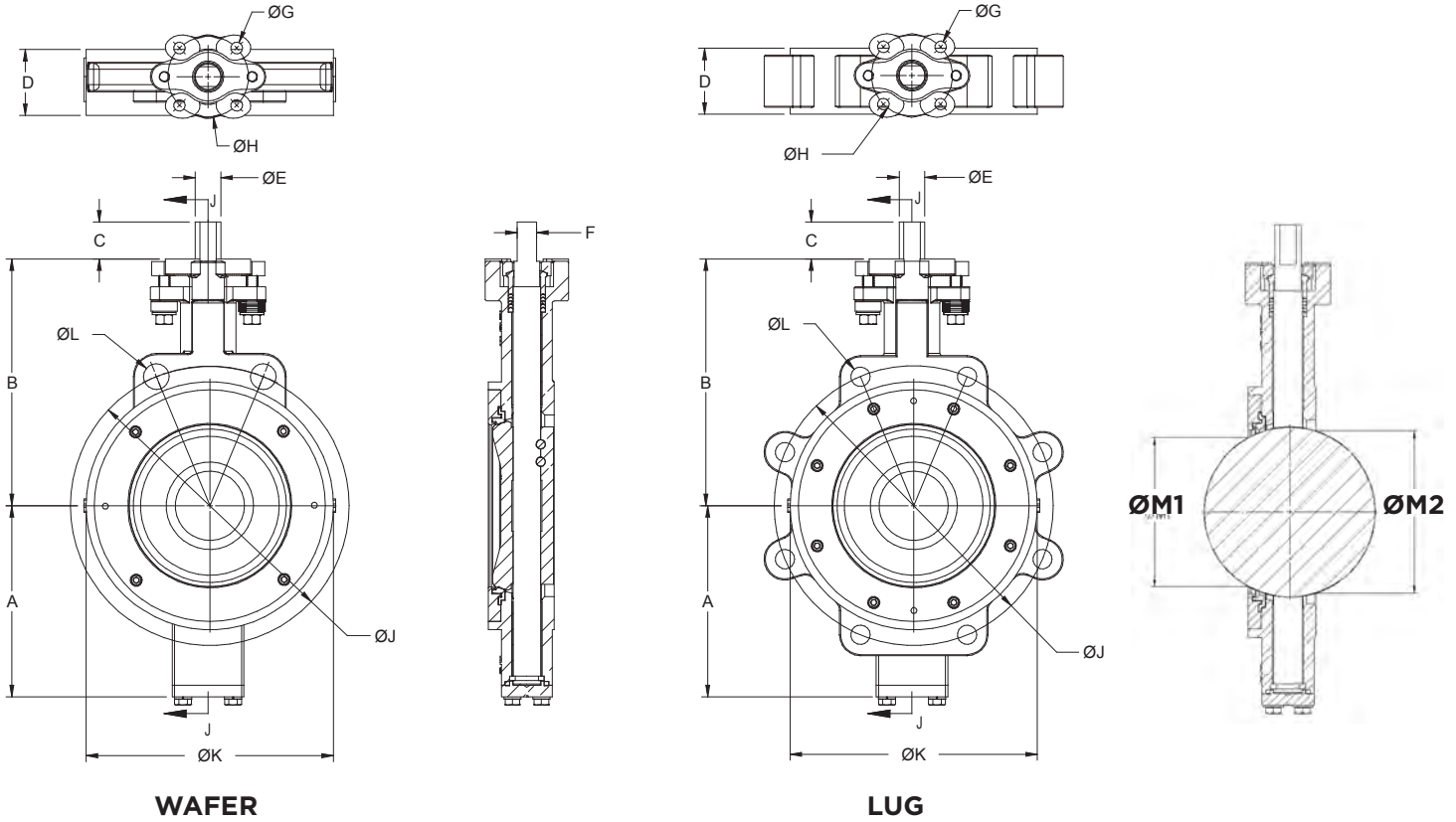

600 CLASS
DOUBLE-D AND KEYED STEM

SIZE (IN.)	SIZE DN	DIMENSIONS (IN.)														
		A	B	C	D	ØE	F	KEY	ØG	ØH**	ØJ	ØK	ØL WAFER	ØL LUG	ØM1	ØM2
3	80	4.705	6.496	1.260	2.126	0.713	0.551	--	4 x 0.394	2.756 (F07)	6.62	5.71	2 x 0.866	8 x 3/4"-10 UNC-2B	1.87	2.68
4	100	5.748	7.717	1.260	2.520	0.874	0.669	--	4 x 0.551	4.921 (F12)	8.50	6.85	2 x 0.984	8 x 7/8"-9 UNC-2B	2.79	3.37
6	150	7.953	9.724	2.165	3.071	1.417	--	0.375	4 x 0.551	4.921 (F12)	11.50	9.45	4 x 1"-8UNC-2B	12 x 1"-8 UNC-2B	4.52	5.26
8	200	9.528	11.614	3.150	4.016	1.890	--	0.500	4 x 0.906	6.496 (F16)	13.75	11.65	4 x 1-1/8"-8UN-2B	12 x 1-1/8"-8 UN-2B	6.14	6.82
10	250	11.024	13.386	3.150	4.606	1.969	--	0.500	4 x 0.906	6.496 (F16)	17.00	13.86	4 x 1-1/4"-8UN-2B	16 x 1-1/4"-8 UN-2B	7.99	8.61
12	300	12.913	15.354	4.331	5.512	2.362	--	0.625	8 x 0.709	10.000 (F25)	19.25	16.34	4 x 1-1/4"-8UN-2B	20 x 1-1/4"-8 UN-2B	9.56	10.13

(5" size not available)

** ISO 5211 mounting/drilling pattern (F size) shown in parentheses.



**RTFM & UHMWPE SEAT
HANDLE & GEAR DIMENSIONS**

CLASS 150

RTFM & UHMWPE SEAT

VALVE SIZE		GEAR RATIO	DIMENSIONS IN INCHES						
INCHES	DN		A	B	C	D	E	F	G
2"	50	37:1	2.24	2.11	7.87	11.81	2.09	1.14	8.82
2.5"	65	37:1	2.24	2.11	7.87	11.81	2.09	1.14	8.82
3"	80	37:1	2.24	2.11	7.87	11.81	2.09	1.14	8.82
4"	100	37:1	2.24	2.11	7.87	11.81	2.09	1.14	12.82
5"	125	37:1	2.24	2.11	7.87	11.81	2.09	1.14	12.82
6"	150	37:1	2.24	2.11	7.87	11.81	2.09	1.14	12.82
8"	200	37:1	2.76	2.11	10.94	11.81	2.09	1.50	22.00
10"	250	37:1	2.76	2.11	10.94	11.81	2.09	1.50	22.00
12"	300	34:1	3.43	2.50	12.87	11.81	2.80	1.59	22.00
14"	350	55:1	4.06	4.39	13.07	15.75	4.11	1.93	—
16"	400	55:1	4.06	4.39	13.07	15.75	4.11	1.93	—
18"	450	55:1	4.06	4.39	13.07	15.75	4.11	1.93	—
20"	500	55:1	4.06	4.39	13.07	15.75	4.11	1.93	—
24"	600	52:1	4.96	4.92	13.11	15.75	5.12	2.40	—
30"	750	280:1	6.65	7.48	18.90	24.00	7.00	3.54	—
36"	850	360:1	8.15	9.06	20.90	24.00	8.26	4.29	—

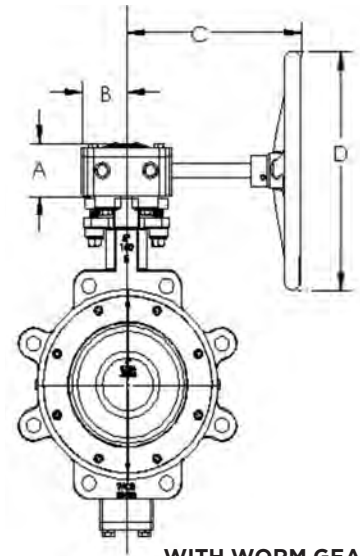

WITH WORM GEAR

BUTTERFLY VALVES

CLASS 300

RTFM & UHMWPE SEAT

VALVE SIZE		GEAR RATIO	DIMENSIONS (IN.)						
INCHES	DN		A	B	C	D	E	F	G
2"	50	37:1	2.24	2.11	7.87	11.81	2.09	1.14	8.82
2.5"	65	37:1	2.24	2.11	7.87	11.81	2.09	1.14	8.82
3"	80	37:1	2.24	2.11	7.87	11.81	2.09	1.14	8.82
4"	100	37:1	2.24	2.11	7.87	11.81	2.09	1.14	12.82
5"	125	37:1	2.76	2.11	10.94	11.81	2.09	1.50	12.82
6"	150	37:1	2.76	2.11	10.94	11.81	2.09	1.50	12.82
8"	200	34:1	3.43	2.50	12.87	11.81	2.80	1.59	22.00
10"	250	34:1	3.43	2.50	12.87	11.81	2.80	1.59	22.00
12"	300	55:1	4.06	4.39	13.07	15.75	4.11	1.93	—
14"	350	55:1	4.06	4.39	13.07	15.75	4.11	1.93	—
16"	400	55:1	4.06	4.39	13.07	15.75	4.11	1.93	—
18"	450	52:1	4.96	4.92	13.11	15.75	5.12	2.40	—
20"	500	280:1	6.65	7.48	18.90	24.00	7.00	3.54	—
24"	600	280:1	6.65	7.48	18.90	24.00	7.00	3.54	—

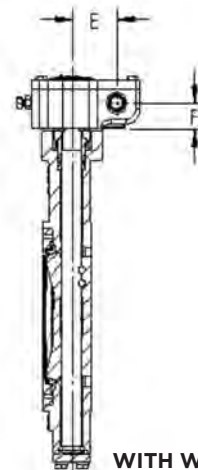

WITH WORM GEAR

CLASS 600

RTFM SEAT

VALVE SIZE		GEAR RATIO	DIMENSIONS (IN.)					
INCHES	DN		A	B	C	D	E	F
3"	80	37:1	2.24	2.11	7.87	11.81	2.09	1.14
4"	100	37:1	2.76	2.11	10.94	11.81	2.09	1.50
6"	150	34:1	2.76	2.11	10.94	11.81	2.09	1.50
8"	200	55:1	4.06	4.39	13.07	15.75	4.11	1.93
10"	250	55:1	4.06	4.39	13.07	15.75	4.11	1.93
12"	300	52:1	4.96	4.92	13.11	15.75	5.12	2.40

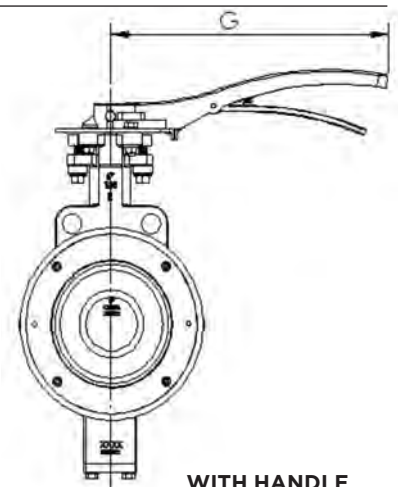

WITH HANDLE



**FIRE SAFE & METAL SEAT
HANDLE & GEAR DIMENSIONS**

**CLASS 150
FIRE SAFE & METAL SEAT**

VALVE SIZE		GEAR RATIO	DIMENSIONS (IN.)						
INCHES	DN		A	B	C	D	E	F	G
2"	50	37:1	2.24	2.11	7.87	11.81	2.09	1.14	8.82
2.5"	65	37:1	2.24	2.11	7.87	11.81	2.09	1.14	8.82
3"	80	37:1	2.24	2.11	7.87	11.81	2.09	1.14	8.82
4"	100	37:1	2.24	2.11	7.87	11.81	2.09	1.14	12.82
5"	125	37:1	2.24	2.11	7.87	11.81	2.09	1.14	12.82
6"	150	37:1	2.24	2.11	7.87	11.81	2.09	1.14	12.82
8"	200	37:1	2.76	2.11	10.94	11.81	2.09	1.50	22.00
10"	250	34:1	3.43	2.50	12.87	11.81	2.80	1.59	22.00
12"	300	55:1	4.06	4.39	13.07	15.75	4.11	1.93	22.00
14"	350	55:1	4.06	4.39	13.07	15.75	4.11	1.93	—
16"	400	55:1	4.06	4.39	13.07	15.75	4.11	1.93	—
18"	450	52:1	4.96	4.92	13.11	15.75	5.12	2.40	—
20"	500	52:1	4.96	4.92	13.11	15.75	5.12	2.40	—
24"	600	280:1	6.65	7.48	18.90	24.00	7.00	3.54	—

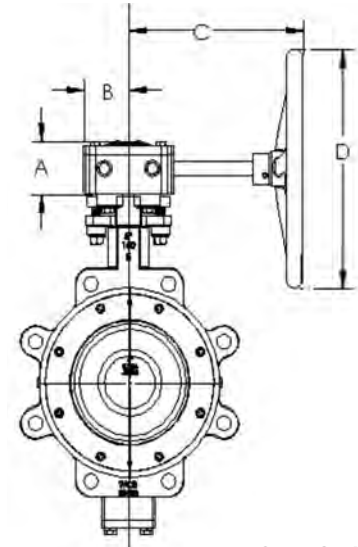

WITH WORM GEAR

**CLASS 300
FIRE SAFE & METAL SEAT**

VALVE SIZE		GEAR RATIO	DIMENSIONS (IN.)						
INCHES	DN		A	B	C	D	E	F	G
2"	50	37:1	2.24	2.11	7.87	11.81	2.09	1.14	8.82
2.5"	65	37:1	2.24	2.11	7.87	11.81	2.09	1.14	8.82
3"	80	37:1	2.24	2.11	7.87	11.81	2.09	1.14	8.82
4"	100	37:1	2.24	2.11	7.87	11.81	2.09	1.14	12.82
5"	125	37:1	2.76	2.11	10.94	11.81	2.09	1.50	12.82
6"	150	37:1	2.76	2.11	10.94	11.81	2.09	1.50	12.82
8"	200	34:1	3.43	2.50	12.87	11.81	2.80	1.59	22.00
10"	250	55:1	4.06	4.39	13.07	15.75	4.11	1.93	22.00
12"	300	55:1	4.06	4.39	13.07	15.75	4.11	1.93	—
14"	350	52:1	4.96	4.92	13.11	15.75	5.12	2.40	—
16"	400	52:1	4.96	4.92	13.11	15.75	5.12	2.40	—
18"	450	280:1	6.65	7.48	18.90	24.00	7.00	3.54	—
20"	500	280:1	6.65	7.48	18.90	24.00	7.00	3.54	—
24"	600	360:1	8.15	9.06	20.90	24.00	8.26	4.29	—

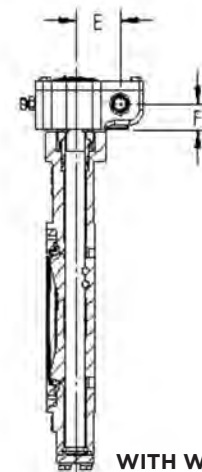

WITH WORM GEAR

**CLASS 600
FIRE SAFE & METAL SEAT**

VALVE SIZE		GEAR RATIO	DIMENSIONS (IN.)					
INCHES	DN		A	B	C	D	E	F
3"	80	37:1	2.24	2.11	7.87	11.81	2.09	1.14
4"	100	34:1	3.43	2.50	12.87	11.81	2.80	1.59
6"	150	55:1	4.06	4.39	13.07	15.75	4.11	1.93
8"	200	55:1	4.06	4.39	13.07	15.75	4.11	1.93
10"	250	52:1	4.96	4.92	13.11	15.75	5.12	2.40
12"	300	280:1	8.86	5.91	15.04	17.72	9.02	3.23

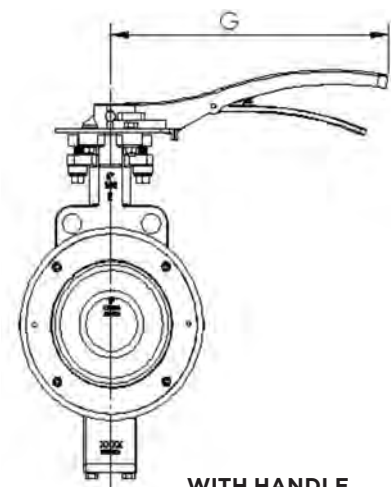

WITH HANDLE

"Apollo"®

PNEUMATIC ACTUATORS

DOUBLE ACTING D-2
SPRING RETURN D-2

ELECTRIC ACTUATORS D-3

ACTUATION ACCESSORIES D-4

ACTUATION



PNEUMATIC RACK & PINION ACTUATORS



Designed and manufactured for the ultimate in durability and reliability, the new Apollo® pneumatic rack & pinion actuators provide outstanding service life.

Apollo® rack & pinion actuators have replaceable insert drive adapters in all but the largest models, and many units have dual "F" series bolt patterns. The numerous actuator drive and bolt pattern combinations allow direct mounting of several valve styles.

FEATURES

- Cast Aluminum Body and Die Cast Aluminum End Caps with Yellow Chromate Powder Coat Finish
- Hard Anodized Die Cast Aluminum Pistons
- Hard-Coat Anodized Finished Aluminum Alloy Pinion
- Hard-Coat Anodized Finished Extruded Aluminum Drive Inserts
- Delta-Tone® Coated Preloaded Concentric Springs
- Polyoxymethylene (POM) Bushings
- O-Ring Seals
Standard Temp. (-4°F to 180°F): Buna-N
High Temp. (-4°F to 250°F): Fluorocarbon
Low Temp. (-40°F to 180°F): Silicone
- Stainless Steel or Delta-Tone® Coated Capscrews, Nuts & Other Hardware

BENEFITS

- Compact Rack & Pinion Design
- Quarter-Turn Operation
- Designed for Use on a Variety of Valve Types: Ball Valves, Butterfly Valves, Plug Valves
- Applicable to Damper and Door Openers
- Both Double-Acting and Spring-Return Units
- Double-Acting Torque Outputs from 220 in-lb to 3547 in-lb with an 80 psi Air Supply
- Removable/Replaceable Drive Inserts*
- Pre-Loaded Spring Assemblies
- ISO 5211 Valve Mounting
- NAMUR (VDI/VDE 3845) Accessory Mounts
- ATEC Classification II, 2 GD, Zones 1 or 2 (Gases) and 21 or 22 (Dust)
- Anti Blowout Pinion Design
- Maximum Pressure Rating: 116 psig (8 bar)
- Compatible Media: Clean, Dry Air, Filtered Non-corrosive Gas or Light Hydraulic Oil
- Pre-lubricated for the Life of the Actuator
- Chromate Corrosion Protection on all Aluminum Components
- Each Unit is Serialized
- 5 Year Apollo® Warranty

*A wide selection of standard inserts are available for square, DIN, and Double-D drives.

PART NUMBER MATRIX

A	S	1600	N	04	1	A	F
PREFIX	ACTION	SIZE	SEAL OPTION	SPRING SET	LIMIT STOP	INSERTS	"AS" MODEL ONLY
A	D - DOUBLE ACTING	0600	N - NITRILE (NORMAL TEMP RANGE, -4° TO 175°F)	00 (DA)	0 - NONE** (STD. ON SIZES 0012, 2500, & 4000)	A - STANDARD SQUARE	ADD SUFFIX "F" IF SPRING-TO-OPEN (I.E. FAIL OPEN). OTHERWISE, LEAVE BLANK
	S - SPRING RETURN	0950		01		B - WITHOUT	
	K - KIT	1600	H - FLOUROCARBON (HIGH TEMP RANGE, -4° TO 250°F)	02	1 - SINGLE ADJUSTABLE LIMIT STOP (FOR SIZES 0025 THRU 1600 ONLY)		
		2500*		03			
		4000*	L - SILICONE (LOW TEMP RANGE, -40° TO 175°F)	04	2 - DUAL ADJUSTABLE LIMIT STOPS (FOR SIZES 0025 THRU 1600 ONLY)		
				05			
				06			
				07			
				08			
				10			
				12			
				14			

* No insert adapter options

** Optional double stroke adjustment plate is available for 2500 & 4000 (see price list)

**AE SERIES
ELECTRIC ACTUATOR**



**4-20MA POSITIONER FEATURES
(P - OPTION)**

ADVANCED PROTECTION FEATURES

- Stall Detection - Motor Will Not Burn Out from Stalling
- Fault Signal - Fault LED on DHC-100 front panel
- Duty Cycle Protection:
 - Allows Actuators Rated for 25% Duty or More, to be Safely Modulated
 - Activates Prior to Tripping of Thermal Overload Protector, which Prevents Long Shut Down Periods due to tripping Thermal Overload Protector; Allows the Actuator to Continue to Move to Set-Point at a 25% Duty Cycle Speed

PERFORMANCE FEATURES

- High Resolution ($\pm 0.1^\circ$) - 450 Points of Resolution on a 1/4 Turn Valve
- Dynamic Braking - Stops Motor Before Changing Actuator Direction and before Mechanical Brake Engages, which Reduces Brake Wear
- Adaptive Control - Designed to Maintain High Resolution and Accuracy by Continuously Monitoring and Compensating for Actuator Backlash, Motor Coast, and Load Changes to Eliminate Positioner Deadband

**4-20MA POSITION TRANSMITTER FEATURES
(T - OPTION)**

- High Resolution Feedback Transmitter:
 - Provides Voltage or mA Output that can be set for any Range 0 to 10 VDC in 0.0016 V steps or 0 to 20 mA in 0.0031 mA steps)
- Auto/Manual Station (Local Control Unit - LCU)
- Polarity Detection

Ruggedly built and designed for easy installation, new Apollo® AE Series electric actuators deliver the most standard features and performance in their class. **Now CSA listed all sizes as standard.**

FEATURES FIVE OUTPUT TORQUES, ONE HOUSING

- 200, 400, 600, 800 and 1,000 in-lb
- Long Service Life
- Anodized Die Cast Aluminum Housing
- Fiberglass Reinforced Nylon Cover Resists Corrosion
- Nitrile Gasket and Seals Cover all Penetration Points in Housing and Cover
- Precision Cut and Heat Treated Alloy Spur Gears
- Permanently Lubricated Enclosed Gear Train
- NEMA 4, 4X

EASY TO USE

- Two Separate 1/2" NPT Conduit Entrances for Easier Wiring and Signal Separation
- 12-Position Pre-Wired Terminal Strip Includes Standard Connections for Remote open/closed position indicators; Lots of Room for Wiring Options
- Unrestricted Mounting Orientation
- Built-In Thermal Overload Protection in all AC Motor Actuators
- Limit Switches Have an 11 Amp Rating at 115 VAC
- High Visibility Valve Position Indicator Standard on all Models

MANY STANDARD FEATURES

- Stainless Steel Push-and-Turn Manual Override Shaft, Position Indicator Shaft and Female Output
- ISO 5211 F07 Drive Output Reduces Inventory of Mounting Kits
- 115 AC & 220 AC Models Feature a 25% Duty Cycle Below 100°F (24AC — 20% Duty Cycle Below 100°F)
- 12 and 24 DC — All DC Voltage Models Provide 100% Duty Cycle for 1 Hour After Which DC Motor is Reduced to 80% Duty Cycle
- Reversible Rotation

BROAD TEMPERATURE RANGE

- Operates From -40°F (When Equipped with 15 Watt Heater and Thermostat) to 150°F

AVAILABLE OPTIONS

- Actuators can be Ordered with One, Two or Three Additional Limit Switches
- For Low Temperatures, Actuators Can Be Equipped With A Thermostatically Controlled Heater Element
- Motor Brake is Necessary When Mounting Actuator to a Butterfly Valve

AE -	400 -	3	BF
PREFIX	TORQUE (IN - LB)	VOLTAGE	OPTIONS
AE	200	1 - 115 VAC	0 - STANDARD
	400	2 - 24 VAC	A - ONE EXTRA SWITCH & CAM*
	600	3 - 220 VAC	B - TWO EXTRA SWITCHES & CAMS*
	800	4 - 12 VDC	C - THREE EXTRA SWITCHES AND CAMS*
	1000	5 - 24 VDC	D - HEATER AND THERMOSTAT (15 WATT)
	ENTER ALL DIGITS OF TORQUE VALUE		F - MOTOR BRAKE (115 VAC & 24 VAC ONLY)
			H - TROPICAL HEATER (15 WATTS)
			P - POSITIONER 4-20 MA
			T - TRANSMITTER 4-20 MA

Note: AE will always be the first two characters of the part number; all digits from torque value must be entered into part number (i.e. 400, 1000, etc.) Only use one digit for voltage depiction (i.e. 1-5). For the options listing you may use more than one character, up to three, (i.e. O, AD or BD etc.)

1 Year warranty on positioner & positioner with transmitter
Transmitter available with (P) positioner option only
Positioner & transmitter are not CSA listed
* Not available with "P" option

EXAMPLE
AE-400-2BF:
 400 in-lb.; 24 VAC; 2 extra switches and cams, motor brake

AE-1000-1D:
 1000 in-lb.; 115 VAC; Heater and thermostat



ACCESSORIES

VALVE POSITION MONITORS

Here's the ultimate in valve monitoring: Position monitors feature a high visibility, color-coded indicator to display valve position. All monitors are designed to correspond to the latest NAMUR standard for actuator/position monitoring units. Plated steel or stainless steel mounting kits are available to provide a pre-engineered mounting solution for maximizing position monitor performance and direct mounting to actuators. Multiple brands available.



SOLENOIDS

Apollo® actuators can be supplied with solenoids manufactured by AVC (Automatic Valve Company). Our 3/4 way, field convertible, direct mount (NAMUR pattern) solenoid valves feature a variety of interchangeable integrated molded coils. They're compatible with both spring return and double acting actuators.

POSITIONERS

Apollo® valve positioners are excellent tools for increasing the gain of your valve package, often reducing your actuator size due to your increased ability to accurately control higher air deliveries, and the flexibility to add options and accessories to complete your control package's performance.

Their simple design makes PMV positioners (shown here) easy to understand, calibrate and repair. Rugged construction provides operation in a variety of tough applications. Compact size minimizes space requirements. A complete package means the user can select the right positioner for his application. A bright indicator makes it easy for operators to visually check the valve position. Spool valve design requires very little maintenance. The electro-pneumatic unit eliminates the need for an extra product and additional connections. PMV positioners are proven products recognized for providing years of reliable service. Other brands are also available from your Apollo® distributor.

Apollo® offers both pneumatic and electro-pneumatic positioners as standard. Pneumatic positioners may be used on either double acting or spring return actuators. The anodized aluminum housing provides excellent product integrity and good corrosion resistance. Options include special coatings, stainless steel housings and a variety of accessory items which can help you meet your most demanding control applications.



"Apollo"®

10-100	E-3, E-4
10-300	E-3, E-4
10-400	E-3, E-4
10-624	E-3, E-4
10-634	E-3, E-4
10-322	E-5, E-6
10-512	E-5, E-6
10-600	E-7 - E-9
12-200	E-10, E-13
13-100	E-11, E-13
13-200	E-11, E-13
13-500	E-11, E-13
14-200	E-12, E-13
14-400	E-14 - E17
14-500	E-14 - E17
14-600	E-15 - E-17
15-100	E-18, E-19
16-200	E-20
16LF-200	E-20
16-500	E-21
16LF-500	E-21
17-400	E-22
18C-400	E-23
18C-500	E-24
19	E-25 - E-29
29	E-30 - E-34
119	E-35 - E-39
DPE	E-40
500	E-41 - E-47

SAFETY RELIEF VALVES

PRESSURE RELIEF VALVE SELECTION CHART

MODEL	MATERIAL BODY / TRIM	INLET SIZES MIN / MAX, IN.	INLET SIZES MIN / MAX, MM	CONNECTIONS		CE/PED AVAILABLE	SET PRESSURES MIN / MAX, PSIG	SET PRESSURES MIN / MAX, BARG	TEMPERATURE MAX, °F	TEMPERATURE MAX, °C
				NPT	FLANGED					
ASME SECTION I - STEAM POWER BOILERS										
19M	Bronze / Brass	1/2 - 2-1/2	DN 15 - 65	X		X	15 - 250	1.0 - 17.2	406°F	207.7°C
19K	Bronze / Brass	1/2 - 2-1/2	DN 15 - 65	X		X	15 - 250	1.0 - 17.2	406°F	207.7°C
19L	Bronze / Stainless	1/2 - 2-1/2	DN 15 - 65	X		X	15 - 250	1.0 - 17.2	406°F	207.7°C
19S	Bronze / Stainless	1/2 - 2-1/2	DN 15 - 65	X		X	15 - 300	1.0 - 20.7	422°F	216.7°C
29	Bronze / Brass	3/8 - 1-1/4	DN 10 - 32	X		X	30 - 200	2.0 - 13.8	406°F	207.7°C
119	Cast Iron / Stainless	1-1/2 - 6	DN 40 - 150	X	X	X	15 - 250	1.0 - 17.2	450°F	232.2°C
ASME SECTION IV - LOW PRESSURE STEAM HEATING BOILERS										
12	Bronze / Brass	2 - 3	DN 50 - 80	X			5 - 15	0.34 - 1.0	250°F	121.1°C
13-101	Bronze / Brass	3/4	DN 20	X			5 - 15	0.34 - 1.0	250°F	121.1°C
13-202	Bronze / Brass	1	DN 25	X			5 - 15	0.34 - 1.0	250°F	121.1°C
13-211	Bronze / Brass	3/4	DN 20	X			5 - 15	0.34 - 1.0	250°F	121.1°C
13-213	Bronze / Brass	1-1/4	DN 32	X			5 - 15	0.34 - 1.0	250°F	121.1°C
13-214	Bronze / Brass	1-1/2	DN 40	X			5 - 15	0.34 - 1.0	250°F	121.1°C
13-510	Bronze / Brass	3/4	DN 20	X			5 - 15	0.34 - 1.0	250°F	121.1°C
14-200	Bronze / Brass	2 - 3	DN 50 - 80	X			5 - 15	0.34 - 1.0	250°F	121.1°C
ASME SECTION IV - HOT WATER HEATING & SUPPLY BOILERS										
10-100	Bronze / Brass	3/4	DN 20	X			20 - 65	1.4 - 4.5	250°F	121.1°C
10-300	Bronze / Brass	3/4	DN 20	X			20 - 65	1.4 - 4.5	250°F	121.1°C
10-400	Bronze / Brass	3/4	DN 20	X			30	2.0	250°F	121.1°C
10-410	Bronze / Brass	3/4	DN 20	X			20 - 80	1.4 - 5.5	250°F	121.1°C
10-600, 10-610	Bronze / Brass	3/4 - 2	DN 20 - 50	X		X	15 - 160	1.0 - 11.0	250°F	121.1°C
10-624, 10-634	Bronze / Brass	3/4	DN 20	X			30 - 150	2.0 - 10.3	250°F	121.1°C
17-401	Bronze / Brass	1/2	DN 15	X			75 - 160	5.2 - 11.0	250°F	121.1°C
17-402	Bronze / Brass	3/4	DN 20	X			75 - 150	5.2 - 10.3	250°F	121.1°C
18C-400	Bronze / Brass	1/2 - 3/4	DN 15 - 20	X			125 - 175	8.61 - 12.1	210°F	98.9°C
18C-500	Bronze / Stainless	3/4 - 2	DN 20 - 50	X			75 - 150	5.2 - 10.3	210°F	98.9°C
ASME SECTION VIII AIR / GASES										
15	Brass	1/4 - 1	DN 8 - 25	X		X	15 - 250	1.0 - 17.2	325°F	162.8°C
19M	Bronze / Brass	1/2 - 2-1/2	DN 15 - 65	X		X	8 - 300	0.55 - 20.7	406°F	207.7°C
19K	Bronze / Brass	1/2 - 2-1/2	DN 15 - 65	X		X	15 - 300	1.0 - 20.7	406°F	207.7°C
19L	Bronze / Stainless	1/2 - 2-1/2	DN 15 - 65	X		X	15 - 300	1.0 - 20.7	406°F	207.7°C
19S	Bronze / Stainless	1/2 - 2-1/2	DN 15 - 65	X		X	8 - 300	0.55 - 20.7	422°F	216.7°C
29	Bronze / Brass	3/8 - 1-1/4	DN 10 - 32	X		X	30 - 200	2.0 - 13.8	406°F	207.7°C
119	Cast Iron / Stainless	1-1/2 - 6	DN 40 - 150	X	X	X	8 - 250	0.55 - 17.2	450°F	232.2°C
510	Bronze / Brass	1/2 - 2	DN 15 - 50	X		X	8 - 300	0.55 - 20.7	406°F	207.7°C
520	Bronze / Stainless	1/2 - 2	DN 15 - 50	X		X	8 - 1200	0.55 - 82.7	422°F	216.7°C
530	Steel / Stainless	1/2 - 2	DN 15 - 50	X	X	X	8 - 1200	0.55 - 82.7	800°F	426.7°C
540	Stainless / Stainless	1/2 - 2	DN 15 - 50	X	X	X	8 - 1200	0.55 - 82.7	800°F	426.7°C
ASME SECTION VIII STEAM										
10-322	Brass	3/4	DN 20	X		X	15 - 60	1.0 - 4.1	325°F	162.8°C
10-512	Brass	1/2	DN 15	X		X	9 - 60	0.62 - 4.1	325°F	162.8°C
19M	Bronze / Brass	1/2 - 2-1/2	DN 15 - 65	X		X	8 - 250	0.55 - 17.2	406°F	207.7°C
19K	Bronze / Brass	1/2 - 2-1/2	DN 15 - 65	X		X	15 - 250	1.0 - 17.2	406°F	207.7°C
19L	Bronze / Stainless	1/2 - 2-1/2	DN 15 - 65	X		X	15 - 250	1.0 - 17.2	406°F	207.7°C
19S	Bronze / Stainless	1/2 - 2-1/2	DN 15 - 65	X		X	8 - 300	0.55 - 20.7	422°F	216.7°C
29	Bronze / Brass	3/8 - 1-1/4	DN 10 - 32	X		X	30 - 200	2.0 - 13.8	406°F	207.7°C
119	Cast Iron / Stainless	1-1/2 - 6	DN 40 - 150	X	X	X	8 - 250	0.55 - 17.2	450°F	232.2°C
510	Bronze / Brass	1/2 - 2	DN 15 - 50	X		X	8 - 250	0.55 - 17.2	406°F	207.7°C
520	Bronze / Stainless	1/2 - 2	DN 15 - 50	X		X	8 - 300	0.55 - 20.7	422°F	216.7°C
530	Steel / Stainless	1/2 - 2	DN 15 - 50	X	X	X	8 - 900	0.55 - 62.1	800°F	426.7°C
540	Stainless / Stainless	1/2 - 2	DN 15 - 50	X	X	X	8 - 900	0.55 - 62.1	800°F	426.7°C
ASME SECTION VIII LIQUID										
510	Bronze / Brass	1/2 - 2	DN 15 - 50	X		X	8 - 300	0.55 - 20.7	406°F	207.7°C
520	Bronze / Stainless	1/2 - 2	DN 15 - 50	X		X	8 - 1200	0.55 - 82.7	422°F	216.7°C
530	CS / Stainless	1/2 - 2	DN 15 - 50	X	X	X	8 - 1200	0.55 - 82.7	800°F	426.7°C
540	Stainless / Stainless	1/2 - 2	DN 15 - 50	X	X	X	8 - 1200	0.55 - 82.7	800°F	426.7°C
NON-CODE, VACUUM & MISCELLANEOUS PRODUCTS										
14-400, 14-500	Low Pressure Air	2 - 3	DN 50 - 80	X			4 - 22	0.3 - 1.52	400°F	204.4°C
14-600	Vacuum Relief	2 - 3	DN 50 - 80	X			8 - 30 HG	203 - 762 MM HG	400°F	204.4°C
16-200/16LF-200	Liquids	1/2	DN 15	X			30 - 80	2.1 - 12.4	120°F	48.9°C
16-501	Adj. Liquid Bypass	1/2	DN 15	X			50 - 600	0 - 41.4	200°F	93.3°C
16-503, 16-504/16LF	Calibrated Liquid Relief	1/2 - 3/4	DN 15 - 20	X			50 - 175	3.4 - 12.1	200°F	93.3°C
Drip Pan Elbows	Steam Discharge	3/4 - 8	DN 20 - 200	X	X		N/A	N/A	450°F	232.2°C

SAFETY RELIEF VALVES

10 (RVW) SERIES

HOT WATER BOILER SAFETY RELIEF



Brass/bronze safety relief valves protect ASME Section IV hot water heating boilers and hydronic heating systems. High capacity design features corrosion resistant construction. Brass, satin or polished chrome finishes available.

ASME SECTION IV

- Inlet Size 3/4" - Outlet - 3/4" & 1"
- Factory Set Pressure 20-150 psi
- Maximum Temperature Service: 250°F

APPLICATIONS

- Ideal for Use With Hot Water Boilers and Hydronic Heating Systems

FEATURES

- Pressures From 20 to 150 psig
- Registered in all Canadian Provinces and Territories, CRN #0G8547.5C
- Stainless Steel Springs Standard
- 10-624/634 are Ideal for Use in Various Plumbing Systems, Commercial Boiler Applications and Swimming Pool Heaters
- 10-418/417 are Ideal for Use in Swimming Pool Heater Applications

OPTIONS

- Models 10-104 and 10-301 are Available with Optional Satin or Polished Chrome Finish
- 10-321 Available in Polished Chrome Only

AVAILABLE CONFIGURATIONS

MODEL NUMBER	SIZE(IN./MM)		CERTIFIED PRESSURE RANGE PSIG	HEIGHT (IN./MM)	WT./100 (LB./KG)
	INLET NPT	OUTLET NPT			
10-102	3/4 F	1 F	20-60	3.94	105
	20 F	25 F		100	47.7
10-104	3/4 M	1 F	20-60	3.75	109
	20 M	25 F		95	49.5
10-301	3/4 M	3/4 F	20-60	3.75	114
	20 M	20 F		95	51.8
10-303	3/4 F	3/4 F	20-60	3.94	115
	20 F	20 F		100	52.3
10-321	3/4 M	3/4 F	20-60	3.75	123
	20 M	20 F		95	55.9
10-407	3/4 M	3/4 F	30	3	62
	20 M	20 F		76	28.2
10-408	3/4 F	3/4 F	30	2.75	65
	20 F	20 F		70	29.5
10-417	3/4 M	3/4 F	20-80	3	62
	20 M	20 F		76	28.1
10-418	3/4 F	3/4 F	20-80	2.75	65
	20 F	20 F		70	29.5
10-624	3/4 M	3/4 F	30-150	4.62	106
	20 M	20 F		117	48.2
10-634	3/4 F	3/4 F	30-150	4.62	106
	20 F	20 F		117	48.2



**10-102
10-303**



**10-104
10-301**



10-321



**10-407
10-417**



**10-408
10-418**



**10-624
10-634 OEM**

SAFETY RELIEF VALVES

10 (RVW) SERIES

HOT WATER BOILER SAFETY RELIEF

ASME SECTION IV - HOT WATER

British thermal units per hour (kilocalories per hour) at 10% overpressure. National Board Certified. Ratings are 90% of actual.

US CUSTOMARY UNITS BTU/HR.

MODEL NO.	10-102 10-104	10-301 10-303	10-321	10-407 10-408	10-417 10-418	10-624 10-634
SET PRESSURE PSIG						
5*	-	225,000	175,000	-	-	-
10*	-	295,000	230,000	-	-	-
15	-	365,000	285,000	-	-	-
20	545,000	420,000	325,000	-	377,000	-
25	625,000	485,000	375,000	-	427,000	-
30	710,000	550,000	425,000	535,000	477,000	689,000
35	790,000	610,000	475,000	-	532,000	769,000
40	870,000	675,000	525,000	-	587,000	848,000
45	955,000	740,000	575,000	-	642,000	928,000
50	1,035,000	805,000	625,000	-	697,000	1,007,000
55	1,115,000	870,000	675,000	-	752,000	1,087,000
60	1,200,000	935,000	725,000	-	807,000	1,166,000
65	-	-	-	-	862,000	1,246,000
70	-	-	-	-	917,000	1,325,000
75	-	-	-	-	972,000	1,405,000
80	-	-	-	-	1,027,000	1,484,000
85	-	-	-	-	-	1,564,000
90	-	-	-	-	-	1,643,000
95	-	-	-	-	-	1,723,000
100	-	-	-	-	-	1,802,000
105	-	-	-	-	-	1,882,000
110	-	-	-	-	-	1,961,000
115	-	-	-	-	-	2,041,000
120	-	-	-	-	-	2,120,000
125	-	-	-	-	-	2,199,000
130	-	-	-	-	-	2,279,000
135	-	-	-	-	-	2,358,000
140	-	-	-	-	-	2,438,000
145	-	-	-	-	-	2,517,000
150	-	-	-	-	-	2,597,000

* Pressure settings below 15 psi are non-ASME Code.

METRIC UNITS KCAL/HR.

MODEL NO.	10-102 10-104	10-301 10-303	10-321	10-407 10-408	10-417 10-418	10-624 10-634
SET PRESSURE BARG						
0.34	-	57	44	-	-	-
0.69	-	74	58	-	-	-
1.03	-	92	72	-	-	-
1.38	137	106	82	-	95	-
1.72	158	122	95	-	108	-
2.07	179	139	107	135	120	174
2.41	199	154	120	-	134	194
2.76	219	170	132	-	148	214
3.10	241	187	145	-	162	234
3.45	261	203	158	-	176	254
3.80	281	219	170	-	190	274
4.14	303	236	183	-	204	294
4.48	-	-	-	-	217	314
4.83	-	-	-	-	231	334
5.17	-	-	-	-	245	354
5.51	-	-	-	-	259	374
5.86	-	-	-	-	-	394
6.20	-	-	-	-	-	414
6.55	-	-	-	-	-	435
6.89	-	-	-	-	-	454
7.24	-	-	-	-	-	475
7.58	-	-	-	-	-	495
7.93	-	-	-	-	-	515
8.27	-	-	-	-	-	535
8.62	-	-	-	-	-	555
8.96	-	-	-	-	-	575
9.31	-	-	-	-	-	595
9.65	-	-	-	-	-	615
10.00	-	-	-	-	-	635
10.34	-	-	-	-	-	655

SAFETY RELIEF VALVES

P/N SUFFIX KEY

SET PRESSURE PSIG	EXTERIOR FINISH		
	PLAIN BRASS	SATIN CHROME	POLISHED CHROME
20	-02	-41	-67
22	-03	-42	-68
25	-04	-43	-69
30	-05	-44	-70
35	-06	-45	-71
40	-07	-46	-72
43	-08	-47	-73
45	-09	-48	-74
50	-10	-49	-75
55	-11	-50	-76
60	-12	-51	-77
65	-13		
70	-14		
75	-15		
80	-16		

ORDERING CODE

Use two-digit suffix number to indicate set pressure and body finish. Suffix for 10-624 / 10-634 models is actual set pressure in psig.

EXAMPLE:
 10-301-44 = 3/4" 10-301 set @ 30 psig, satin chrome finish.
 10-624-125 = 3/4" 10-624 set @ 125 psig (plain bronze finish only)

NOTE:

- Model 10-321 available in polished chrome finish only.
- All other models are furnished with plain bronze finish.
- Model 10-104 and 10-301 available with optional satin or polished chrome finish.

10-322 (RVS32) & 10-512 (RVS52) SERIES
OEM STYLE STEAM SAFETY RELIEF



10-512



10-322

National Board capacity-certified safety valves; brass body with optional satin or polished chrome finish. Protects against excess pressure from thermal expansion and steam caused by failure of BTU input controls.

ASME SECTION VIII

- Sizes 1/2" and 3/4"
- Factory Set Pressures 15 to 60 psig @ 312°F max
- National Board Certified Capacity

APPLICATIONS

- Ideally suited for OEM applications such as steam carpet and jewelry cleaners, autoclaves, sterilizers, commercial pressure cookers, steam jacketed kettles, dental equipment, coffee makers and similar equipment.

FEATURES

- Stainless Steel Springs
- Small Physical Size
- Discharge Capacities to 725 lb./hr.
- Soft Seating for Exceptional Seat Tightness
- Pressure Settings 15 to 60 psig
- 10-322 in Polished Chrome Only (10-322-P)
- CRN OG8547.5C, Registered in all Canadian Provinces and Territories
- More Descriptive Model Numbering System

OPTIONS

- (Model 10-512 Only)
- Satin or Polished Chrome Finish
- Stainless Steel Wetted Trim
- BSP Pipe Connections
- CE/PED Compliance

AVAILABLE CONFIGURATIONS

MODEL NUMBER	SIZE (IN./MM)		SET PRESSURE RANGE PSIG	HEIGHT (IN./MM)	WT./100 (LB./KG)
	INLET NPT	OUTLET NPT			
10-322	3/4 M	3/4 F	20-60	3.75	128
	20	20		95	58.2
10-512	1/2 M	1/2 F	15-60	2.62	58
	15	15		67	26.4

P/N SUFFIX KEY

SET PRESSURE PSIG	*CERTIFIED CAPACITIES	
	10.322 LB.HR	15.512 LB.HR
15	-	151
20	325	178
25	375	205
30	425	232
35	475	258
40	525	285
45	575	312
50	625	339
55	675	366
60	725	392

* ASME (UV) Rating - 90% of actual capacity at 10% accumulation. Capacity in lb. of saturated steam per hour.

PART NUMBER MATRIX

10-X	-X	-XX	-X
MODEL AND SIZE (IN.)	FINISH	SET PRESSURE	OPTIONS
512 - 1/2 X 1/2	B - PLAIN BRASS	SET PRESSURE IN PSIG (2 DIGITS)	B - BSPP CONNECTIONS
322 - 3/4 X 3/4	S - SATIN CHROME		CE - PED/CE
	P - POLISHED CHROME		S - STAINLESS STEEL TRIM
			V - VITON® SEAT
			X - BLANK OUTLET NOT THREADED

EXAMPLE:
10-322-P-20 = 3/4" 10-322 set @ 20 psig, polished chrome finish.
NOTE:

- Model 10-322 available in polished chrome finish only.
- Valves may be set for any pressure between 15 and 60 psig.

SAFETY RELIEF VALVES

10-322 (RVS32)
OEM STYLE STEAM SAFETY RELIEF

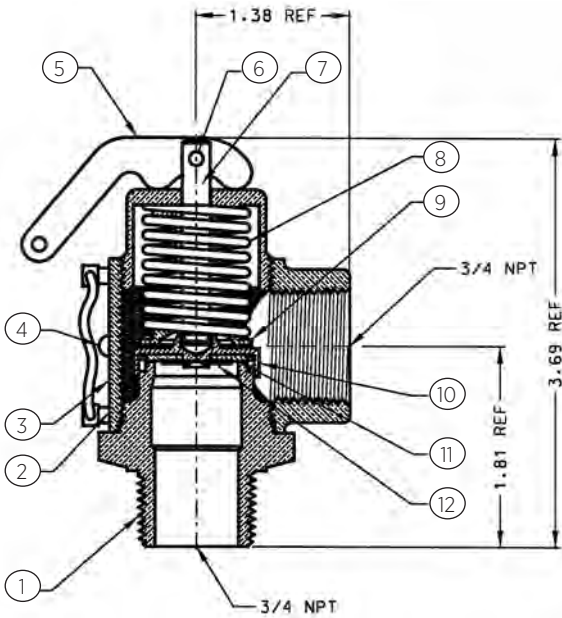

STANDARD MATERIAL LIST

1	Nozzle	Brass, ASTM B-16
2	Body	Brass, ASTM B-16
3	Nameplate	Aluminum
4	Drive Screw	Steel, Zinc Plated
5	Handle	Steel, Zinc Plated
6	Cotter Pin	Steel, Zinc Plated
7	Stem	Brass, ASTM B-16
8	Spring	Stainless Steel
9	Spring Washer	Brass, ASTM B-16
10	Disc	Brass, ASTM B-16
11	Seat	Teflon Faced EPDM
12	Washer	Brass, ASTM B-16

SAFETY RELIEF VALVES

10-512 (RVS52)
OEM STYLE STEAM SAFETY RELIEF

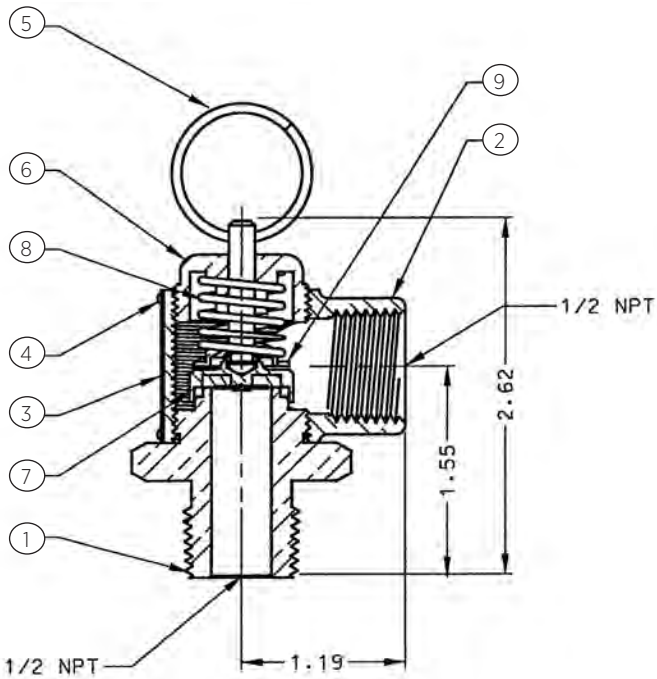

STANDARD MATERIAL LIST

1	Nozzle	Brass, ASTM B-16
2	Body	Brass, ASTM B-16
3	Nameplate	Aluminum
4	Drive Screw	Steel, Zinc Plated
5	Pull Ring	Steel, Zinc Plated
6	Cap	Brass, ASTM B-16
7	Disc Assembly	Brass, Silicone
8	Spring	Stainless Steel
9	Spring Washer	Brass, ASTM B-16

Model 10-512 available with optional stainless steel wetted trim. Nozzle, disc holder and disc washer are type 316 stainless steel.

10-600 (RVW) SERIES

HIGH CAPACITY HOT WATER BOILER SAFETY RELIEF

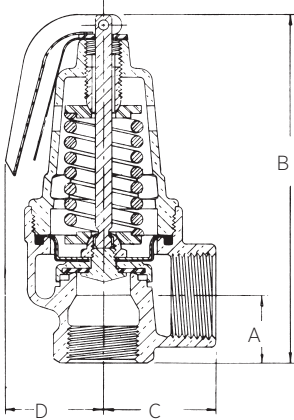

High-capacity heating system valves with female inlet and standard or expanded female outlet. Elevated seat for drainage of water away from seat area. Entire pressure range is National Board capacity certified.

ASME SECTION IV

- Inlet Sizes 3/4" to 2"
- Factory Set Pressures from 15-160 psig
- Maximum Temperature Service 250°F

APPLICATIONS

- Hot water heating boilers and hot water supply systems

FEATURES

- High BTU Capacity Rating
- Silicone Seat
- Fabric Reinforced Molded Diaphragm Isolates Spring from Water at all Times
- Bronze Body and Spring Cage
- Registered in Canadian Provinces and Territories, CRN #0G8547.5C
- Protects Against Excessive Water Pressure Due to Failure of Controls to Regulate BTU Input

AVAILABLE CONFIGURATIONS

MODEL NUMBER	SIZE(IN./MM)		CERTIFIED PRESSURE RANGE PSIG	WT./100 (LB./KG)	DIMENSIONS (IN./MM)			
	INLET NPT	OUTLET NPT			A	B	C	D
10-604	3/4F	3/4F	15-160	232	1.03	5.25	1.62	1.56
	20	20		105.2	26	133	41	39
10-614	3/4F	1 F	15-160	226	1.03	5.25	1.72	1.56
	20	25		102.5	26	133	43	39
10-605	1F	1F	15-160	410	1.25	6.69	2.00	2.00
	25	25		185.9	31	169	50	50
10-615	1 F	1-1/4F	15-160	390	1.25	6.69	2.00	2.00
	25	32		176.9	31	169	50	50
10-606	1-1/4F	1-1/4F	15-160	795	1.25	8.37	2.47	2.62
	32	32		360.5	31	212	63	67
10-616	1-1/4F	1-1/2F	15-160	755	1.25	8.37	2.47	2.62
	32	40		342.4	31	212	63	67
10-607	1-1/2F	1-1/2F	15-160	1100	2.00	10.75	2.75	3.12
	40	40		498.9	50	273	69	79
10-617	1-1/2F	2F	15-160	1145	2.00	10.75	2.75	3.12
	40	50		519.3	50	273	69	79
10-608	2F	2F	15-160	2375	2.19	14.00	3.69	3.50
	50	50		1077.1	55	355	93	88
10-618	2F	2-1/2F	15-160	2315	2.19	14.00	3.66	3.50
	50	65		1049.9	55	355	92	88

P/N SUFFIX KEY

SET PRESSURE PSIG	SUFFIX	SET PRESSURE PSIG	SUFFIX
15	-01	85	-17
20	-02	90	-18
22	-03	95	-19
25	-04	100	-20
30	-05	105	-21
35	-06	110	-22
40	-07	115	-23
43	-08	120	-24
45	-09	125	-25
50	-10	130	-30
55	-11	135	-31
60	-12	140	-32
65	-13	145	-33
70	-14	150	-34
75	-15	155	-35
80	-16	160	-36

ORDERING CODE

- Use two-digit suffix number to indicate Inlet x Outlet size and set pressure.

EXAMPLE:
 10-615-12 = 1" x 1-1/4" 10-610 set 60 psig
 10-608-05 = 2" x 2" 10-600 set 30 psig

SAFETY RELIEF VALVES

10-600 (RVW) SERIES
HIGH CAPACITY HOT WATER BOILER SAFETY RELIEF

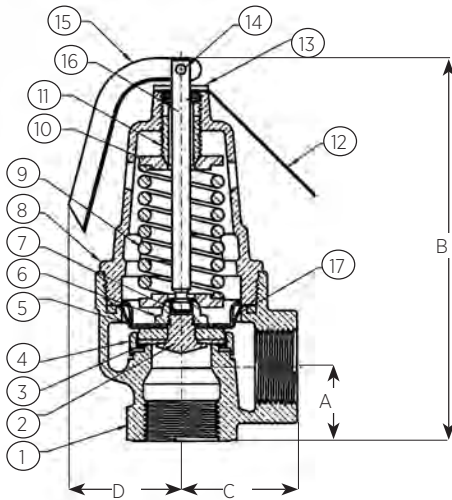

STANDARD MATERIAL LIST

1	Body	Bronze Alloy C84400
2	Seat Insert	Brass, ASTM B-16
3	Seat	Silicone
4	Disc	Brass ASTM B-16
5	Diaphragm	Fabric Reinforce EPDM
6	Stem Nut	Steel, Plated
7	Spacer	Silicone
8	Cap	Bronze Alloy C84400
9	Spring	PLated ASTM A228
10	Spring Washer	AISI 12L14 Steel
11	Adj. Screw	Brass, ASTM B-16
12	Nameplate	Aluminum
13	Lift Washer	Steel, Plated
14	Handle Rivet	Steel, Plated
15	Lift Handle	Steel, Plated
16	Stem Nut	Steel, Plated
17	Diaphragm Ret.	Steel, Plated

ASME SECTION IV HOT WATER

- British thermal units per hour (kilocalories per hour) at 10% overpressure. National Board Certified. Ratings are 90% of actual.

US CUSTOMARY UNITS BTU/HR.

MODEL NO.	10-604 3/4 X 3/4	10-605 1 X 1	10-606 1-1/4 X 1-1/4	10-607 1-1/2 X 1-1/2	10-608 2 X 2
SET PRESSURE PSIG					
15	541,000	876,000	1,515,000	2,061,000	3,397,000
20	636,000	1,030,000	1,782,000	2,424,000	3,996,000
25	732,000	1,185,000	2,049,000	2,788,000	4,595,000
30	827,000	1,339,000	2,316,000	3,151,000	5,193,000
35	923,000	1,493,000	2,583,000	3,514,000	5,792,000
40	1,018,000	1,648,000	2,850,000	3,878,000	6,391,000
45	1,113,000	1,802,000	3,117,000	4,241,000	6,990,000
50	1,209,000	1,956,000	3,384,000	4,604,000	7,589,000
55	1,304,000	2,111,000	3,651,000	4,968,000	8,188,000
60	1,399,000	2,265,000	3,918,000	5,331,000	8,786,000
65	1,495,000	2,420,000	4,185,000	5,694,000	9,385,000
70	1,590,000	2,574,000	4,453,000	6,058,000	9,984,000
75	1,686,000	2,728,000	4,720,000	6,421,000	10,583,000
80	1,781,000	2,883,000	4,987,000	6,784,000	11,182,000
85	1,876,000	3,037,000	5,254,000	7,148,000	11,780,000
90	1,972,000	3,192,000	5,521,000	7,511,000	12,379,000
95	2,067,000	3,346,000	5,788,000	7,874,000	12,978,000
100	2,162,000	3,500,000	6,055,000	8,238,000	13,577,000
105	2,258,000	3,655,000	6,322,000	8,601,000	14,176,000
110	2,353,000	3,809,000	6,589,000	8,964,000	14,775,000
115	2,449,000	3,963,000	6,856,000	9,327,000	15,373,000
120	2,544,000	4,118,000	7,123,000	9,691,000	15,972,000
125	2,639,000	4,272,000	7,390,000	10,054,000	16,571,000
130	2,735,000	4,427,000	7,657,000	10,417,000	17,170,000
135	2,830,000	4,581,000	7,924,000	10,781,000	17,769,000
140	2,925,000	4,735,000	8,191,000	11,144,000	18,368,000
145	3,021,000	4,890,000	8,458,000	11,507,000	18,966,000
150	3,116,000	5,044,000	8,725,000	11,871,000	19,565,000
155	3,212,000	5,199,000	8,992,000	12,234,000	20,164,000
160	3,307,000	5,353,000	9,260,000	12,597,000	20,763,000

METRIC UNITS Kcal/HR.

MODEL NO.	10-604 20 X 20	10-605 25 X 25	10-606 32 X 32	10-607 40 X 40	10-608 50 X 50
SET PRESSURE BARG					
1.03	136	221	382	520	857
1.38	160	260	449	611	1,008
1.72	185	299	517	703	1,159
2.07	209	351	584	795	1,310
2.41	233	377	651	886	1,461
2.76	257	416	719	978	1,612
3.10	281	454	786	1,070	1,763
3.45	305	493	853	1,161	1,914
3.79	329	532	921	1,253	2,065
4.14	353	571	988	1,344	2,219
4.48	377	610	1,055	1,436	2,367
4.83	401	649	1,123	1,528	2,518
5.17	425	688	1,190	1,619	2,669
5.51	449	727	1,258	1,711	2,820
5.86	473	766	1,325	1,803	2,971
6.20	497	805	1,393	1,894	3,122
6.55	521	844	1,560	1,986	3,273
6.89	545	883	1,527	2,076	3,424
7.24	569	922	1,594	2,169	3,575
7.58	593	961	1,662	2,261	3,726
7.93	618	999	1,729	2,352	3,877
8.27	642	1,039	1,796	2,444	4,028
8.62	666	1,077	1,864	2,536	4,179
8.96	690	1,116	1,931	2,627	4,330
9.31	714	1,155	1,998	2,719	4,481
9.65	738	1,194	2,066	2,811	4,632
10.00	762	1,233	2,133	2,902	4,783
10.34	786	1,272	2,200	2,994	4,934
10.69	810	1,311	2,268	3,085	5,085
11.03	834	1,350	2,335	3,177	5,236



10-610 (RVW) SERIES

HIGH CAPACITY HOT WATER BOILER SAFETY RELIEF

ASME SECTION IV - HOT WATER

• British thermal units per hour (kilocalories per hour) at 10% overpressure. National Board Certified. Ratings are 90% of actual.

US CUSTOMARY UNITS BTU/HR.

MODEL NO.	10-614 3/4 X 1	10-615 1 X 1-1/4	10-616 1-1/4 X 1-1/2	10-617 1-1/2 X 2	10-618 2 X 2-1/2
SET PRESSURE PSIG					
15	635,000	1,027,000	1,777,000	2,417,000	3,984,000
20	746,000	1,208,000	2,090,000	2,843,000	4,686,000
25	858,000	1,389,000	2,403,000	3,270,000	5,389,000
30	970,000	1,570,000	2,716,000	3,696,000	6,091,000
35	1,082,000	1,751,000	3,030,000	4,122,000	6,793,000
40	1,194,000	1,933,000	3,343,000	4,548,000	7,496,000
45	1,306,000	2,114,000	3,656,000	4,974,000	8,198,000
50	1,418,000	2,295,000	3,969,000	5,400,000	8,900,000
55	1,529,000	2,476,000	4,283,000	5,826,000	9,603,000
60	1,641,000	2,657,000	4,596,000	6,252,000	10,305,000
65	1,753,000	2,838,000	4,909,000	6,679,000	11,007,000
70	1,865,000	3,019,000	5,222,000	7,105,000	11,710,000
75	1,977,000	3,200,000	5,535,000	7,531,000	12,412,000
80	2,089,000	3,381,000	5,849,000	7,957,000	13,114,000
85	2,201,000	3,562,000	6,162,000	8,383,000	13,817,000
90	2,313,000	3,743,000	6,475,000	8,809,000	14,519,000
95	2,424,000	3,924,000	6,788,000	9,235,000	15,221,000
100	2,536,000	4,105,000	7,101,000	9,661,000	15,924,000
105	2,648,000	4,286,000	7,415,000	10,088,000	16,626,000
110	2,760,000	4,468,000	7,728,000	10,514,000	17,328,000
115	2,872,000	4,649,000	8,041,000	10,940,000	18,031,000
120	2,984,000	4,830,000	8,354,000	11,366,000	18,733,000
125	3,096,000	5,011,000	8,668,000	11,792,000	19,435,000
130	3,207,000	5,192,000	8,981,000	12,218,000	20,138,000
135	3,319,000	5,373,000	9,294,000	12,644,000	20,840,000
140	3,431,000	5,554,000	9,607,000	13,070,000	21,543,000
145	3,543,000	5,735,000	9,920,000	13,497,000	22,245,000
150	3,655,000	5,916,000	10,234,000	13,923,000	22,947,000
155	3,767,000	6,097,000	10,547,000	14,349,000	23,650,000
160	3,879,000	6,278,000	10,860,000	14,775,000	24,352,000

METRIC UNITS Kcal/HR.

MODEL NO.	10-614 20 X 25	10-615 25 X 32	10-616 32 X 40	10-617 40 X 50	10-618 50 X 65
SET PRESSURE BARG					
1.03	160	259	448	610	1,005
1.38	188	305	527	717	1,182
1.72	216	350	606	825	1,359
2.07	245	396	645	932	1,536
2.41	273	442	765	1,040	1,713
2.76	301	488	843	1,147	1,890
3.10	329	533	922	1,254	2,067
3.45	358	579	932	1,362	2,244
3.79	386	624	1,080	1,469	2,422
4.14	414	670	1,159	1,577	2,599
4.48	442	716	1,238	1,684	2,776
4.83	470	761	1,317	1,792	2,953
5.17	498	807	1,396	1,899	3,130
5.51	527	827	1,475	2,007	3,307
5.86	555	898	1,554	2,114	3,485
6.20	583	944	1,633	2,222	3,662
6.55	611	990	1,712	2,329	3,839
6.89	640	1,035	1,791	2,437	4,016
7.24	668	1,081	1,870	2,544	4,193
7.58	696	1,127	1,949	2,652	4,370
7.93	724	1,172	2,028	2,759	4,547
8.27	752	1,218	2,107	2,866	4,724
8.62	781	1,264	2,186	2,974	4,901
8.96	809	1,309	2,265	3,081	5,079
9.31	837	1,355	2,344	3,189	5,256
9.65	865	1,401	2,423	3,296	5,433
10.00	893	1,446	2,502	3,404	5,610
10.34	922	1,492	2,581	3,511	5,787
10.69	950	1,538	2,660	3,619	5,964
11.03	978	1,583	2,739	3,726	6,141

SAFETY RELIEF VALVES

12-200 (RVS12) SERIES

LOW PRESSURE STEAM HEATING BOILER SAFETY



Medium capacity safety valves protect ASME Section IV low pressure steam heating boilers. Cast bronze, full nozzle design features PTFE faced elastomer soft seating for dependable operation. Ideal for OEM applications.

ASME SECTION IV

- Sizes 2", 2-1/2" and 3"
- Factory Set Pressures 5-15 psi

APPLICATIONS

- Medium and Large Commercial and Industrial Steam Heating and Processing Boilers

FEATURES

- All Bronze Construction
- PTFE-Coated O-Ring Seat Seal
- 3/8" NPT Side Tapping for Drain
- Rust-Proofed Steel Spring
- Top Guided, High Capacity Design
- Registered in all Canadian Provinces and Territories, CRN #0G8547.5C
- National Board Certified at 15 psig

AVAILABLE CONFIGURATIONS

MODEL NUMBER	SIZE (IN./MM)		WT./EA. (LB./KG)	DIMENSIONS (IN./MM)			
	INLET NPT	OUTLET NPT		A	B	C	D
12-205	2M	2F	5.1	6.00	3.75	2.62	4.00
	50	50	2.3	152	95	67	102
12-206	2-1/2M	2-1/2F	8.4	8.50	5.25	3.06	4.00
	65	65	3.8	216	133	78	102
12-208	3M	3F	11.6	9.50	6.00	3.75	4.00
	80	80	5.3	241	152	95	102

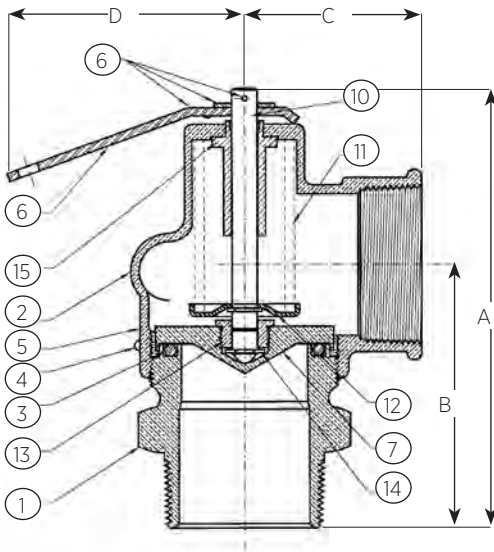

STANDARD MATERIAL LIST

NUMBER	DESCRIPTION	MATERIAL
1	Nozzle	Bronze, ASTM B584
2	Body	Bronze, ASTM B584
3	O-Ring	Teflon [®] Coated EPDM
4	Drive Screw	AISI 1010 Plated CR Steel
5	Nameplate	Aluminum
6	Handle Assembly	Steel, Plated
7	Disc	Brass, ASTM B-16
8	Stem	Brass, ASTM B-16
9	Spring	Stainless Steel
10	Spr. Washer	AISI 1010 Plated CR Steel
11	Stem Nut	Brass, ASTM B-16
12	Retainer Ring	Brass, ASTM B-16
13	Guide	Brass, ASTM B-16

P/N SUFFIX KEY

SET PRESSURE PSIG	SUFFIX
5	-03
6	-04
8	-05
10	-06
12	-07
15	-08

ORDERING CODE

- Use two-digit suffix number to indicate set pressure and body finish.

EXAMPLE:
12-205-08 = 2" 12 Series set 15 psig

13 (RVS13) SERIES

LOW PRESSURE STEAM HEATING BOILER SAFETY

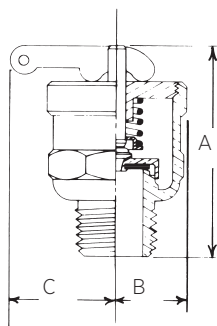

13-101

ASME Section IV bronze safety valves protect small to medium low pressure steam heating boilers. Three design configurations feature top guiding and raised seating area for extended service life. Available top and side discharge models.

ASME SECTION IV

- Inlet Sizes 3/4" to 2"
- Factory Set Pressures from 5-15 psig

APPLICATIONS

- Low Pressure Steam Heating and Supply Boilers

FEATURES

- Flat Seat, PTFE Faced Disc for Positive Seal
- Standard Set Pressure of 15 psig
- Positive Drainage of Condensate from Seat Area
- No. 13-101 is Top Outlet Discharge
- Registered in all Canadian Provinces and Territories, CRN #0G8547.5C
- ASME and National Board Certified at 15 psig

OPTIONS

- Satin or Polished Chrome Finishes

AVAILABLE CONFIGURATIONS

MODEL NUMBER	SIZE (IN./MM)		WT./100 (LB./KG)	DIMENSIONS (IN./MM)			
	INLET NPT	OUTLET NPT		A	B	C	D
13-101	3/4 M	Top	64	2.87	0.94	1.25	-
	20		29.0	73	23	31	-
13-211	3/4 M	3/4 F	107	1.81	3.69	1.44	1.41
	20	20	48.5	46	93	36	35
13-202	1 M	1 F	110	2.06	3.87	1.53	1.41
	25	25	49.9	52	98	39	35
13-213	1-1/4 M	1-1/2 F	218	2.53	4.50	1.87	1.50
	32	40	98.9	64	114	47	38
13-214	1-1/2 M	2 F	320	3	5.25	2.19	1.81
	40	50	145.1	76	133	55	46
13-511	3/4 M	3/4 F	62	1.69	3.25	1.19	1.25
	20	20	28.1	42	82	30	31
13-512	3/4 F	3/4 F	59	1.19	2.75	1.19	1.25
	20	20	26.8	30	69	30	31

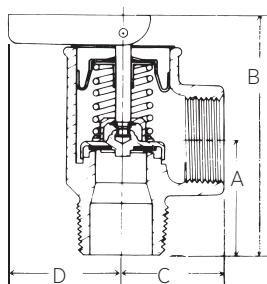

13-511

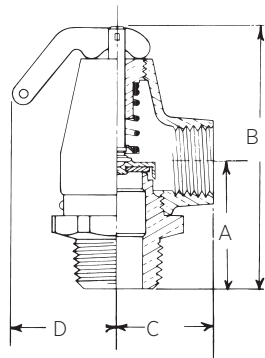

13-200

PART NUMBER MATRIX

13-XXX	-X	-XX	-X
MODEL	FINISH	SET PRESSURE	OPTIONS
101 - 3/4" M X TOP	B - PLAIN BRASS	SET PRESSURE IN PSIG	A - AIR SERVICE (NON-ASME)
211 - 3/4" M X 3/4" F	S - SATIN CHROME*	(2 DIGITS)	
202 - 1" M X 1" F	P - POLISHED CHROME*		
213 - 1-1/4" M X 1-1/2" F	*AVAILABLE ON SELECT MODELS		
214 - 1-1/2" M X 2" F			
511 - 3/4" M X 3/4" F			
512 - 3/4" F X 3/4" F			

EXAMPLE:
13-511-B15 = 3/4" 13-511 set at 15 psig

SAFETY RELIEF VALVES

14-200 (RSV14) SERIES

LOW PRESSURE STEAM HEATING SAFETY

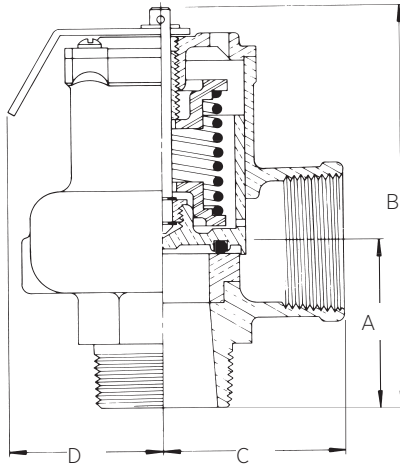
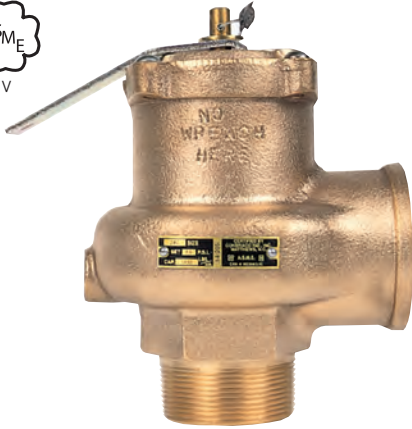

SAFETY RELIEF VALVES

FEATURES

- One Piece Body, All Bronze Construction
- Rust-Proofed Steel Spring
- Chrome Plated Seat, PTFE Coated Disc
- PTFE Coated EPDM O-Ring for Positive Seal
- 3/8" NPT Side Tapping for Drain Connection
- Valves are Capacity Certified by the National Board at 15 psig Only, in Accordance with ASME Boiler and Pressure Vessel Code Section IV
- Registered in all Canadian Provinces and Territories, CRN #0G8547.5C

ASME SECTION IV

- Sizes 2", 2-1/2" and 3"
- Factory Set Pressures 5-15 psi

APPLICATIONS

- The 14 Series is an ASME Section IV High Capacity Steam Safety Valve for Use With Medium and Large Size Commercial and Industrial Heating Boilers

OPTIONS

- (-G) Test Gag Available to Prevent the Valve from Opening During Hydrostatic Boiler Testing

AVAILABLE CONFIGURATIONS

MODEL NUMBER	SIZE (IN./MM)		WT./EA. (LB./KG)	DIMENSIONS (IN./MM)			
	INLET NPT	OUTLET NPT		A	B	C	D
14-205	2M	2F	8.4	3.00	7.12	3.12	4.00
	50M	50F	3.8	76	181	79	101
14-206	2-1/2M	2-1/2F	13.0	3.50	8.25	3.50	4.00
	65M	65F	5.9	88	209	88	101
14-207	3M	3F	17.0	4.12	9.37	3.87	4.00
	80M	80F	7.7	104	238	98	101

ORDERING CODE

- Use model number and two digit suffix number to indicate size and set pressure.

P/N SUFFIX KEY

SET PRESSURE PSIG	SUFFIX
5	-03
6	-04
8	-05
10	-06
12	-07
15	-08

EXAMPLE:
 14-206-08 = 2-1/2" valve set 15 psig
Note:
 ASME IV and NB certified capacities at 15 psi only
 Valves may be set for any pressure between 5 and 15 psi. Consult factory for set pressures not listed.
 To specify test gag option add "G" to suffix.

12, 13 & 14 SERIES

LOW PRESSURE STEAM HEATING BOILER SAFETY

ASME SECTION IV - STEAM

Pounds per hour (kilograms per hour) saturated steam at 33-1/3% overpressure. National Board Certified. Ratings are 90% of actual.

US CUSTOMARY UNITS BTU/HR.

MODEL NO. (IN.)	12-205 2 X 2	12-206 2-1/2 X 2-1/2	12-208 3 X 3	13-101 3/4	13-202 1 X 1	13-211 3/4 X 3/4	13-213 1-1/4 X 1-1/2	13-214 1-1/2 X 2	13-511 13-512 3/4 X 3/4	14-205 2 X 2	14-206 2-1/2 X 2-1/2	14-207 3 X 3
SET PRESSURE PSIG												
5*	1,439	2,043	2,855	333	374	290	699	1,106	213	1,815	2,695	3,944
10*	1,969	2,786	3,478	372	509	383	950	1,503	310	2,483	3,686	5,394
15	2,500	3,529	4,100	410	643	475	1,200	1,900	407	3,150	4,676	6,843

METRIC UNITS KCAL/HR.

MODEL NO. (MM)	12-205 50 X 50	12-206 65 X 65	12-208 80 X 80	13-101 20	13-202 25 X 25	13-211 20X20	13-213 32 X 40	13-214 40 X 50	13-511 13-512 20 X 20	14-205 50 X 50	14-206 65 X 65	14-207 80 X 80
SET PRESSURE BARG												
0.34	653	927	1,295	151	170	131	317	502	97	823	1,222	1,789
0.69	893	1,264	1,577	169	231	174	431	682	141	1,126	1,672	2,447
1.03	1,134	1,601	1,860	186	292	215	544	862	185	1,429	2,121	3,103

*ASME Section IV and NB certified capacities at 15 psi only.
Valves may be set for any pressure between 5 and 15 psi. Consult factory for set pressures not listed.

SAFETY RELIEF VALVES

14-400 & 14-500 (RVA14) SERIES
LOW PRESSURE AIR RELIEF

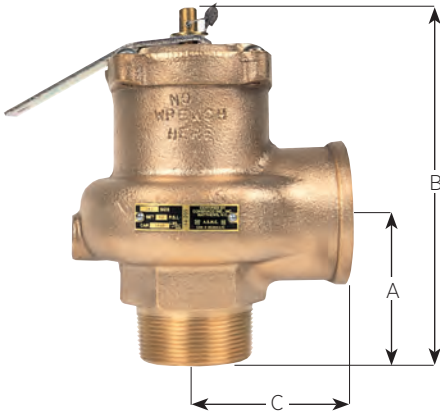

14-400
W/ LIFT LEVER

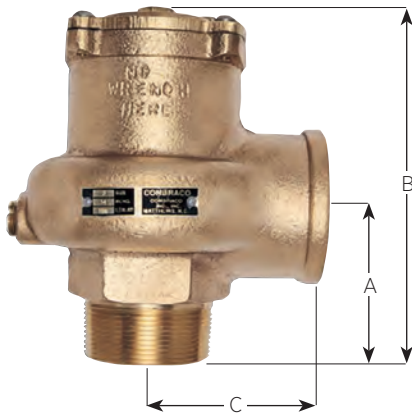

14-500
SEALED CAP

High volume air relief valves designed for low pressure/high volume air and gas service. Rugged bronze construction features elastomer soft seating and TFE coated discs for dependable operation.

- Inlet Sizes 2", 2-1/2" and 3"
- Factory Set Pressures 4 to 22 psig @ 400°F max.

APPLICATIONS

- Non-ASME Code Air and Gas Service
- Low Pressure, High Volume Blowers and Compressors
- Bulk Hauling Tanks, Trailers and Rail Cars
- Powdered Solids / Bulk Handling
- Pneumatic Conveying Equipment

FEATURES

- Vibration Resistant Soft Seat is Standard
- Stainless Steel Spring
- One Piece Corrosion Resistant Bronze Body Design
- High Flow "Top-Guided" Design

OPTIONS

- Model 14-400 with Test Lever
- Model 14-500 with Plain Cap, Weather Resistant Sealed Body

AVAILABLE CONFIGURATIONS

MODEL NUMBER	SIZE (IN./MM)	DIMENSIONS (IN./MM)			WT./EA. (LB./KG)
		A	B	C	
14-X05	2 x 2	3	6-1/2	3-1/8	8.4
	50M x 50F	76	165	79	3.81
14-X06	2-1/2 x 2-1/2	3-1/2	7-5/8	3-1/2	12.5
	65M x 65F	89	194	89	5.7
14-X07	3 x 3	4-1/8	8-3/4	3-7/8	17.0
	80M x 80F	105	222	98	7.7

PART NUMBER MATRIX

14	-X	-XX	-X
SERIES NUMBER	BODY/CAP STYLE AND SERVICE	INLET CONNECTION	RELIEF PRESSURE
14 - BASE MODEL NO.	4 - AIR RELIEF, WITH TEST LEVER	05 - 2" NPT	SET PRESSURE IN PSIG (2 DIGITS)
	5 - AIR RELIEF, PLAIN CAP	06 - 2-1/2" NPT	
		07 - 3" NPT	

EXAMPLE:

14-406 12 = 2-1/2" 14 Series air relief valve set at 12 psig, with lift lever
 14-505-08 = 2" air relief valve set at 8 psig, with sealed cap

**14-600 (RVA14) SERIES
VACUUM RELIEF**

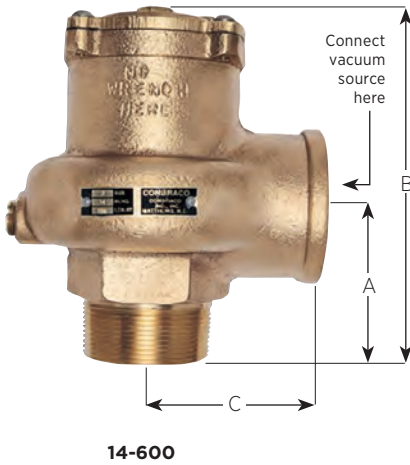

High flow vacuum relief valves feature one piece cast bronze bodies. Teflon coated discs and elastomer soft seating provide accurate and dependable operation.

- Connection Sizes 2", 2-1/2" and 3"
- Relief Settings 8" to 30" Hg @ 400° F max.

APPLICATIONS

- High Volume Vacuum Systems
- Bulk Hauling Tanks and Trailers
- Powdered Solids / Bulk Handling
- Pneumatic Conveying Equipment

FEATURES

- Weather Resistant Construction
- Elastomer Soft Seat is Vibration Resistant
- Stainless Steel Spring
- One Piece Corrosion Resistant Bronze Body Design
- High Capacity "Top-Guided" Design
- TFE / Chrome Plated Internals

AVAILABLE CONFIGURATIONS

MODEL NUMBER	SIZE (IN./MM)	DIMENSIONS (IN./MM)			WT./EA. (LB./KG)
		A	B	C	
14-605	2 x 2	3	6-1/2	3-1/8	8.4
	50M x 50F	76	165	79	3.81
14-606	2-1/2 x 2-1/2	3-1/2	7-5/8	3-1/2	11.8
	65M x 65F	89	194	89	5.4
14-607	3 x 3	4-1/8	8-3/4	3-7/8	16.3
	80M x 80F	105	222	98	7.4

PART NUMBER MATRIX

14	-6	-0X	-VXX
SERIES NUMBER	BODY/CAP STYLE AND SERVICE	INLET CONNECTION	RELIEF PRESSURE
14 - BASE MODEL NO.	6 - VACUUM RELIEF	05 - 2" NPT	VACUUM RELIEF SETTING, HG "V" PREFIX + INCHES MERCURY ("V" + 2 DIGITS)
		06 - 2-1/2" NPT	
		07 - 3" NPT	

EXAMPLE:
14-607-V14 = 3" vacuum relief valve set at 14 in. Hg

SAFETY RELIEF VALVES

14-400 (RVA14) SERIES
LOW PRESSURE AIR RELIEF

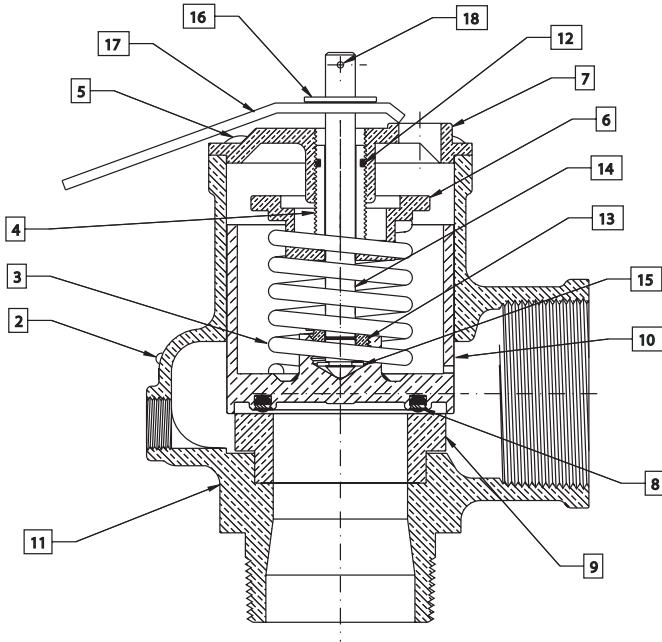

STANDARD MATERIAL LIST

1	Nameplate	Aluminum
2	Drive Screws (2)	Steel, Plated
3	Spring	Stainless Steel
4	Adjusting Screw	Brass, ASTM B-16
5	Cap Screw (4)	Steel, Plated
6	Spring Washer	Brass, ASTM B-16
7	Cap	Bronze, ASTM B-584
8	Seat-O-Ring	Silicone
9	Seat Insert	Brass, ASTM B-16
10	Disc	Bronze, ASTM B-584
11	Body	Bronze, ASTM B-584
12	Friction Ring	EPDM
13	Stem Nut	Brass, ASTM B-16
14	Stem	Brass, ASTM B-16
15	Retaining Ring	Steel, Plated
16	Lift Washer	Steel, Plated
17	Lift Lever	Steel, Plated
18	Roll Pin	Steel, Plated
19	Plug	Brass, ASTM B-16
20	Plug	Brass, ASTM B-16
21	Cap Seal O-Ring	Silicone

14-500 & 14-600 (RVA14) SERIES

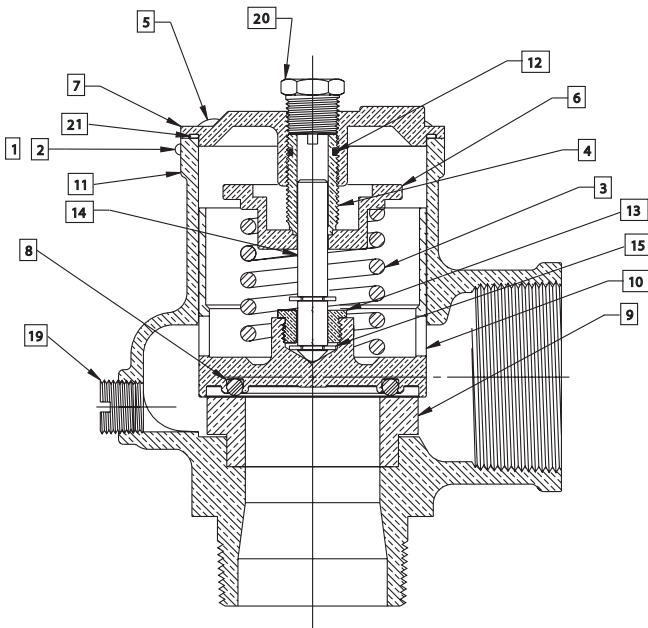

STANDARD MATERIAL LIST

1	Nameplate	Aluminum
2	Drive Screws (2)	Steel, Plated
3	Spring	Stainless Steel
4	Adjusting Screw	Brass, ASTM B-16
5	Cap Screw (4)	Steel, Plated
6	Spring Washer	Brass, ASTM B-16
7	Cap	Bronze, ASTM B-584
8	Seat-O-Ring	Silicone
9	Seat Insert	Brass, ASTM B-16
10	Disc	Bronze, ASTM B-584
11	Body	Bronze, ASTM B-584
12	Friction Ring	EPDM
13	Stem Nut	Brass, ASTM B-16
14	Stem	Brass, ASTM B-16
15	Retaining Ring	Steel, Plated
16	Lift Washer	Steel, Plated
17	Lift Lever	Steel, Plated
18	Roll Pin	Steel, Plated
19	Plug	Brass, ASTM B-16
20	Plug	Brass, ASTM B-16
21	Cap Seal O-Ring	Silicone



14-400 & 14-500 SERIES

LOW PRESSURE AIR RELIEF

NON-CODE AIR RELIEF CAPACITIES

- Standard cubic feet per minute (normalized cubic meters per hour) of air at 10% overpressure.

US CUSTOMARY UNITS SCFM AIR

ORDERING SUFFIX	MODEL NO. SIZE (IN.) AREA (IN. ²)	14-405 14-505 2 X 2 2.238	14-406 14-506 2-1/2 X 2-1/2 3.339	14-407 14-507 3 X 3 5.155
	SET PRESSURE PSIG			
-04	4	615	914	1338
-05	5	651	967	1415
-06	6	687	1020	1492
-07	7	722	1072	1569
-08	8	758	1125	1646
-09	9	793	1178	1723
-10	10	829	1231	1801
-11	11	864	1283	1878
-12	12	900	1336	1955
-13	13	935	1389	2032
-14	14	971	1441	2109
-15	15	1006	1494	2186
-16	16	1041	1547	2263
-17	17	1076	1600	2340
-18	18	1111	1653	2417
-19	19	1146	1706	2494
-20	20	1181	1756	2571
-21	21	1216	1809	2648
-22	22	1252	1861	2725

METRIC UNITS NM3/HR. AIR

MODEL NO. SIZE (MM) AREA (CM ²)	14-405 14-505 50 X 50 14.438	14-406 14-506 65 X 65 21.544	14-407 14-507 80 X 80 33.259
	SET PRESSURE BARG		
.28	988	1469	2151
.34	1046	1554	2275
.41	1104	1639	2398
.48	1161	1724	2522
.55	1218	1809	2646
.62	1275	1893	2770
.69	1332	1978	2894
.76	1389	2063	3018
.83	1446	2147	3142
.90	1503	2232	3266
.97	1560	2317	3390
1.03	1617	2402	3514
1.10	1673	2487	3638
1.17	1730	2572	3761
1.24	1786	2657	3885
1.31	1842	2742	4009
1.38	1899	2823	4133
1.45	1955	2907	4257
1.52	2012	2992	4381

14-600 SERIES

VACUUM RELIEF

VACUUM AIR RELIEF CAPACITIES

- Standard cubic feet per minute (normalized cubic meters per hour) of air at 10% overpressure.

US CUSTOMARY UNITS SCFM AIR

ORDERING SUFFIX	MODEL NO. SIZE (IN.) AREA (IN. ²)	14-605 2 X 2 2.238	14-606 2-1/2 X 2-1/2 3.339	14-607 3 X 3 5.155
	RELIEF SETTING (IN. HG)			
V08	8	395	600	865
V09	9	405	618	890
V10	10	415	635	915
V11	11	421	642	927
V12	12	426	649	939
V13	13	430	653	943
V14	14	430	653	943
V15	15	430	653	943
V20	20	430	653	943
V25	25	430	653	943
V30	30	430	653	943

METRIC UNITS Nm3/Hr. AIR

MODEL NO. SIZE (MM) AREA (CM ²)	14-605 50 X 50 14.438	14-606 65 X 65 21.544	14-607 80 X 80 33.259
	RELIEF SETTING (MM HG)		
203	635	964	1390
229	651	993	1431
254	667	1021	1471
279	676	1043	1509
305	685	1043	1509
330	691	1050	1516
356	691	1050	1516
381	691	1050	1516
508	691	1050	1516
635	691	1050	1516
762	691	1050	1516

15 (RVA15) SERIES
AIR RELIEF

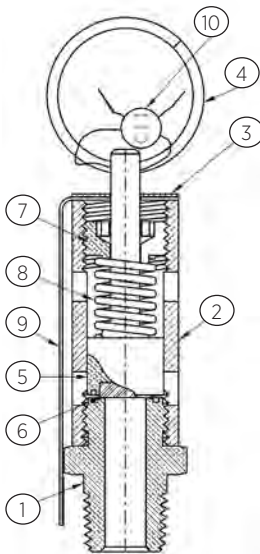

STANDARD MATERIALS LIST

1	Nozzle	Brass, ASTM B-16
2	Body	Brass, ASTM B-16
3	Nameplate	Aluminum
4	Pull Ring	Pltd. AISI 1018 CRS
5	Disc/Stem	Brass, ASTM B-16
6	Seat	Viton
7	Cap	Brass, ASTM B-16
8	Spring	ASTM A-227 Steel
9	Inst. Tag	Paper
10	Lead Seal	Lead

Rugged design 15 Series air relief valves provide dependable overpressure protection at an economical price. Top guided design features brass construction and resilient seating for superior performance. Widely used by OEM's and for aftermarket replacement.

ASME SECTION VIII

- Sizes 1/4" and 1"
- Factory Set Pressures 15 to 250 psig
- Maximum Temperature: 325° F

APPLICATIONS

- Ideal for a Wide Range of Air and Inert Gas Applications Including Compressors, Intercoolers, Dryers, Receivers, Control and Instrument Air Lines, and Pressurized Systems and Equipment

FEATURES

- National Board Certified 15 psig thru 250 psig
- Stainless Steel Springs
- Viton O-Ring Seat
- Registered in all Canadian Provinces and Territories, CRN #0G8547.5C
- ASTM B16 Brass Body
- RoHS Compliant Materials
- European Pressure Equipment Directive Compliant Option (CE/PED)

AVAILABLE CONFIGURATIONS

MODEL NUMBER	INLET SIZE (IN./MM)	DIMENSIONS (IN./MM)		WT./100 (LB./KG)
		A	B	
15-112	1/4 NPT	2.62	0.78	18.5
	8	66	20	8.4
15-115	3/8 NPT	3.25	1.12	42.2
	10	82	28	19.2
15-117	1/2 NPT	3.37	1.12	45.3
	15	85	28	20.6
15-118	3/4 NPT	4.06	1.21	58
	20	105	30	26.4
15-119	1 NPT	5.12	1.87	153
	25	130	47	69.5

PART NUMBER MATRIX

15-XXX	-X	-XXX	-XX
MODEL AND SIZE (IN.)	FINISH	SET PRESSURE	OPTIONS
112 - 1/4 NPT	B - PLAIN BRASS	SET PRESSURE IN PSIG	CE - PED/CE
115 - 3/8 NPT			Q - PERFORMANCE (CALIBRATION) TEST REPORTS
117 - 1/2 NPT			
118 - 3/4 NPT			
119 - 1 NPT			

EXAMPLE:
15 117 B 165 = 1/2" 15 Series set at 165 psig.



15 (RVA15) SERIES

AIR RELIEF

ASME SECTION VIII - AIR

- Standard cubic feet per minute (normalized cubic meters per hour) of air at 10% overpressure. National Board Certified. Ratings are 90% of actual.

US CUSTOMARY UNITS SCFM AIR

MODEL NO. SIZE (IN.)	15-112 1/4	15-115 & 117 3/8 & 1/2	15-118 3/4	15-119 1
SET PRESSURE PSIG				
15	24	60	107	222
20	28	70	124	256
25	32	79	140	290
30	35	88	156	323
35	39	98	174	361
40	43	109	193	398
45	47	119	211	435
50	51	128	229	473
55	55	139	247	510
60	60	149	265	547
65	64	159	283	584
70	68	170	301	622
75	72	179	319	659
80	76	190	337	696
85	80	200	355	734
90	84	210	373	771
95	88	220	391	808
100	92	230	409	845
105	96	241	427	883
110	100	251	445	920
115	104	261	463	957
120	108	271	481	995
125	112	281	499	1,032
130	116	292	517	1,069
135	120	302	535	1,106
140	124	312	553	1,144
145	129	322	571	1,181
150	133	332	589	1,218
155	137	342	607	1,256
160	141	353	625	1,293
165	145	363	644	1,330
170	149	373	662	1,368
175	153	383	680	1,405
180	157	393	698	1,442
185	161	403	716	1,479
190	165	414	734	1,517
195	169	424	752	1,554
200	173	432	770	1,591
205	177	444	788	1,629
210	181	454	806	1,666
215	185	464	824	1,703
220	189	475	842	1,740
225	194	484	860	1,778
230	198	495	878	1,815
235	202	505	896	1,852
240	206	515	914	1,890
245	210	525	932	1,927
250	214	535	950	1,964

METRIC UNITS Nm3/HR. AIR

MODEL NO. SIZE (MM)	15-112 8	15-115 & 117 10 & 15	15-118 20	15-119 25
SET PRESSURE BARG				
1.03	39	96	172	357
1.38	45	112	199	411
1.72	51	127	225	466
2.07	57	141	251	519
2.41	63	157	280	580
2.76	69	175	310	640
3.10	75	191	339	699
3.45	82	206	368	760
3.79	88	223	397	820
4.14	96	239	426	879
4.48	103	255	455	939
4.83	109	273	484	1,000
5.17	116	288	513	1,059
5.51	122	305	542	1,119
5.86	129	321	571	1,180
6.20	135	337	600	1,239
6.55	141	354	628	1,299
6.89	148	370	657	1,358
7.24	154	387	686	1,419
7.58	161	403	715	1,479
7.93	167	419	744	1,538
8.27	174	436	773	1,599
8.62	180	452	802	1,659
8.96	186	469	831	1,718
9.31	193	485	860	1,778
9.65	199	501	889	1,839
10.00	207	518	918	1,898
10.34	214	534	947	1,958
10.69	220	550	976	2,019
11.03	227	567	1,005	2,078
11.38	233	583	1,035	2,138
11.72	239	600	1,064	2,199
12.06	246	616	1,093	2,258
12.41	252	632	1,122	2,318
12.75	259	648	1,151	2,377
13.10	265	665	1,180	2,439
13.44	272	681	1,209	2,498
13.79	278	694	1,238	2,557
14.13	285	714	1,267	2,619
14.48	291	730	1,296	2,678
14.82	298	746	1,325	2,738
15.17	305	763	1,353	2,797
15.51	311	778	1,382	2,858
15.86	318	796	1,411	2,918
16.20	324	812	1,440	2,977
16.55	331	828	1,469	3,038
16.89	337	844	1,498	3,098
17.24	344	860	1,527	3,157

SAFETY RELIEF VALVES

16-200 (RVW16) SERIES
GENERAL PURPOSE PRESSURE RELIEF

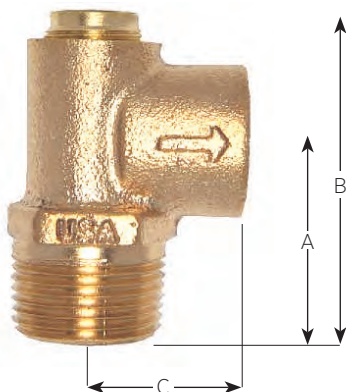

Pressure relief valves relieve excess pressure in cold water supply systems, storage tanks, well pumps. Also suitable for air, oil and other non-hazardous liquids.

FEATURES

- Standard Pressure Settings from 50 to 175 psi
- Cast Bronze Body, Stainless Steel Pprings
- Silicone Soft Seat Ensures Seat Tightness, Extended Service Life
- All Valves are 100% Factory Tested
- Maximum Recommended Service Temperature: 120°F
- Lead Free Option, Model 16LF is NSF/ANSI 372 Lead Free

AVAILABLE CONFIGURATIONS

MODEL NUMBER	LF MODEL NUMBER	INLET SIZE (IN./MM)	DIMENSIONS (IN./MM)			WT./100 (LB./KG)
			A	B	C	
16-202	16LF-202	1/2 M x 1/2 F	1.41	2.12	1.00	33
		15 M x 15 F	36	54	25	15
16-203	16LF-203	3/4 M x 1/2 F	1.41	2.50	1.00	37.5
		20 M x 15 F	36	63	25	17

ORDERING CODE

- Use model number and two digit suffix number to indicate size and set pressure.

P/N SUFFIX KEY

SET PRESSURE PSIG	SUFFIX
50	-01
75	-02
100	-03
125	-04
150	-05
175	-06

EXAMPLE:
16-202-03 = 1/2" model set at 100 psig
NOTE:
Valves may be set for any pressure between 30 and 180 psi. Consult factory for pressure settings not shown.

16-501 (RVW16) SERIES
GENERAL PURPOSE LIQUID RELIEF

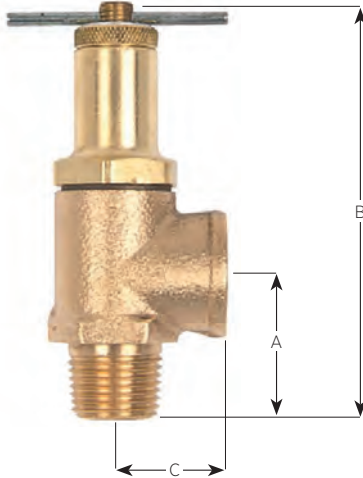

Adjustable relief valves protect equipment by providing low volume liquid relief or bypass control. Excess volume may be discharged back to the low pressure source. Ideal for agricultural sprayers and simple commercial or industrial pressurized systems.

FEATURES

- Adjustable Relief Settings, in Two Ranges to 600 psi
- Cast Bronze Body, Stainless Steel Springs
- Choice of Nitrile (Buna) or PTFE Soft Seats
- Knurled Locknut Locks Pressure Adjustment
- Viton Stem Seal, Polypropylene Body Gasket
- Maximum Recommended Service Temperature: 200°F

AVAILABLE CONFIGURATIONS

MODEL NUMBER	INLET SIZE (IN./MM)	RELIEF RANGE	SEAT MATERIAL	DIMENSIONS (IN./MM)			WT./100 (LB./KG)
				A	B	C	
16-501-01	1/2 M X 1/2 F 15 M x 15 F	50 - 250	Nitrile	1.29 33	4.12 105	1.00 25	62 28
16-501-02		250 - 600					
16-501-25		50 - 250	PTFE				
16-501-60		250 - 600					

16-503 & 16-504 (RVW16) SERIES
GENERAL PURPOSE LIQUID RELIEF

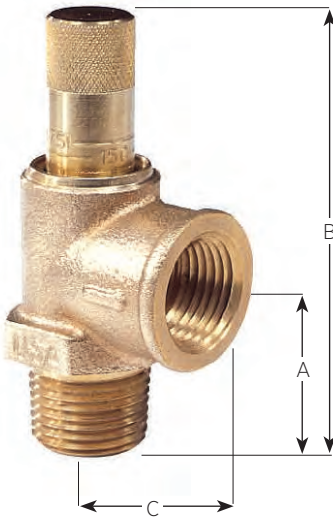

Calibrated pressure relief valve allows for in-line pressure adjustments without the need for a pressure gauge. Provides static overpressure protection for liquid filled systems such as well pumps, tanks, fire protection systems.

FEATURES

- Choice of 1/2" or 3/4" Inlet Connection
- Factory Preset at 100 psi
- Pressure Range 50 to 175 psi, Calibrated in 25 psi Increments
- Cast Bronze Body, Stainless Steel Spring
- Silicone Soft Seat, EPDM Cap Seal
- Maximum Recommended Service Temperature: 200°F
- Lead Free Option, Model 16LF is NSF/ANSI 372 Lead Free

AVAILABLE CONFIGURATIONS

MODEL NUMBER	LF MODEL NUMBER	INLET SIZE (IN./MM)	DIMENSIONS (IN./MM)			WT./100 (LB./KG)
			A	B	C	
16-503-01	16LF-503-01	1/2 M X 1/2 F	1.31 33	3.44 87	1.00 25	37 17
		15 M x 15 F				
16-504-01	16LF-504-01	3/4 M X 1/2 F				
		20 M x 15 F				

17-400 (RVW17) SERIES
PRESSURE ONLY HOT WATER RELIEF

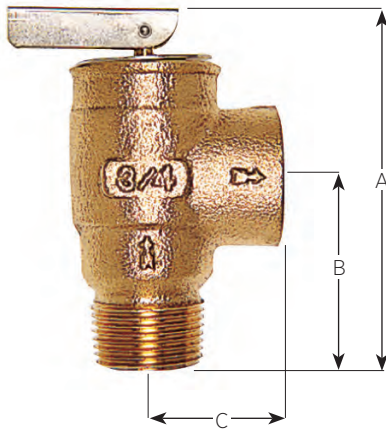

17-400 series pressure only relief valves are engineered to protect against excessive pressure buildup due to thermal expansion in hot water supply systems. Both models are CSA certified to ANSI Z21.22 "Relief Valves for Hot Water Supply Systems". In addition the 17-402 is design certified to ASME Section IV for hot water relief.

- Connection Sizes 1/2" (Model 17-401) and 3/4" (Model 17-402)
- CSA Verified to ANSI Z21.22
- Pressure Settings 75 thru 150 psi @ 250°F max.
- ASME Section IV Hot Water, Model 17-402 Only

APPLICATIONS

- **Model 17-401:** Overpressure Protection of Domestic Tankless Water Heaters. Also Ideal for Protecting Plumbing and Well Systems, Small Liquid Filled Vessels and Similar Equipment from Thermal Expansion or Pressure Surges
- **Model 17-402:** In Addition to the Above, also Suitable for ASME Section IV Hot Water Heating and Supply Boilers and Storage Tanks

FEATURES

- Cast Bronze Body, Stainless Steel Springs
- Soft Seat for Durability, Extended Service Life
- Conforms to HUD / FHA Requirements
- CSA Certified to ANSI Z21.22
- CSA B-51, CRN 0G8547.5C

AVAILABLE CONFIGURATIONS

MODEL NUMBER	INLET SIZE (IN./MM)	CSA CAPACITY RATING	ASME CAPACITY RATING	DIMENSIONS (IN./MM)			WT./100 (LB./KG)
				A	B	C	
17-401	1/2 M X 1/2 F	15,000	-	3.26	1.73	1.16	57
	15 M X 15 F			83	44	29	26
17-402	3/4 M X 3/4 F	200,000	See table below	3.14	1.62	1.13	53
	20 M X 20 F			80	41	29	24

ORDERING CODE

Use model number and two-digit suffix number to indicate size and set pressure.

P/N SUFFIX KEY

SET PRESSURE PSIG	SUFFIX	BTU/HR. / ASME SEC. IV 17-402
75	-01	505,000
100	-02	648,000
125	-03	791,000
150	-04	934,000
160	-05	-

EXAMPLE:
 17-401-03 = 1/2" model 17 set @ 125 psig.
 17-402-04 = 3/4" model 17 set @ 150 psig.
 NOTE:
 Valves may be set for any pressure between 70 and 175 psi.
 Consult factory for pressure settings not shown.
 ASME Section IV certified model 17-402 only, pressure settings 75 to 150 psig.

**18C-400 (TP) & 18C-402X (TPX) SERIES
WATER HEATER T&P RELIEF**

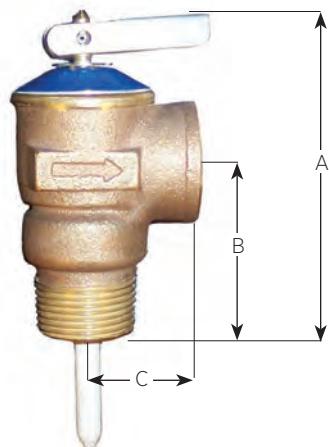

18C-400

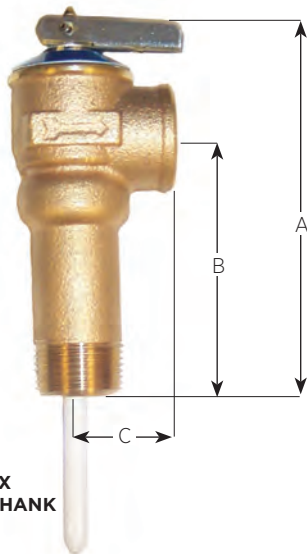

**18C-402X
EXTENDED SHANK**

Special statement regarding T&P Valves and compliance to the Lead Free requirements of the U.S. Safe Drinking Water Act.

Effective January 4th 2014 the SDWA requires that pipes, fittings or fixtures used to convey or dispense potable water must be lead free. Further clarification has been provided by the EPA in a document titled "Summary of the Reduction of Lead In Drinking Water Act and frequently Asked Questions". The latest document can be viewed on our website: www.apollovalves.com

FAQ #6 states that water heaters are covered by the Act and must comply. However most water heater OEM's are certifying their heaters as complete assemblies using non-Lead Free T&P valves due to their relatively small wetted surface area.

FAQ #23 acknowledges this and states that replacement parts (including T&P valves) need not be lead free as long as the entire water heater with all installed components overall device would meet the Lead Free requirements of the Act.

Automatic temperature and pressure relief valves feature unique non-metallic coating which protects the element against galvanic and electromechanical corrosion by isolating it from the heated water. This coating is electrostatically applied for uniform coverage, then thermobonded, resulting in optimum adhesion for extended service life.

- CSA Design Certified at all Settings to ANSI Z21.22
- ASME Section IV Rated at 125 and 150 psig Settings for 3/4 NPT Only

APPLICATIONS

- Temperature and Pressure Protection for Hot Water Heaters and Storage Tanks

FEATURES

- Meets HUD/FHA Requirements
- Cast Bronze Body, Stainless Steel Spring
- Rated @ 210°F Maximum
- CRN Registered in all Canadian Provinces and Territories
- ASME Capacity Certified to 500,000 BTUhr.

OPTIONS

- Model 18C-402X Features a Body Inlet Extended 2" for Insulated Vessels

AVAILABLE CONFIGURATIONS

MODEL NUMBER	SIZE (IN./MM)	ELEMENT LENGTH (IN./MM)	CSA CAPACITY RATING BTU/HR	DIMENSIONS (IN./MM)			WT./100 (LB./KG)
				A	B	C	
18C-401	1/2 M x 1/2 F	1.44, 3 & 8"	15,000	3.25	1.75	1.13	64
	15 M x 15 F	37, 76 & 200		83	44	29	29
18C-402	3/4 M x 3/4 F	1.44"	95,000	3.25	1.75	1.13	64
	20 M x 20 F	37		83	44	29	29
18C-402	3/4 M x 3/4 F	3 & 8"	105,000	3.25	1.75	1.13	64
	20 M x 20 F	76 & 200		83	44	29	29
18C-402X	3/4 M x 3/4 F	3"	105,000	4.51	2.97	1.13	75
	20 M x 20 F	76		115	75	29	34

ORDERING CODE

Use model number and two-digit suffix number to indicate size and set pressure.

P/N SUFFIX KEY - MODEL 18C-401

SET PRESSURE PSIG	COATED ELEMENT LENGTH (IN.)	
	1.44"	3"
125	-27	-29
150	-28	-30

EXAMPLE:
18C-402X-38 = 3/4" model 18C-402X set @ 150 psig with 3" element.

18C-402-30 = 3/4" model 18C-402 set @ 150 psig with 3" element.

P/N SUFFIX KEY - MODEL 18C-402

SET PRESSURE PSIG	COATED ELEMENT LENGTH (IN.)		
	1.44"	3"	8"
125	-27	-29	-36
150	-28	-30	-37
175		-24	

P/N SUFFIX KEY - MODEL 18C-402X - EXTENDED

SET PRESSURE PSIG	COATED ELEMENT LENGTH (IN.)
	3"
125	-39
150	-38

18C (TPC) SERIES

BRONZE HIGH CAPACITY COMMERCIAL T&P

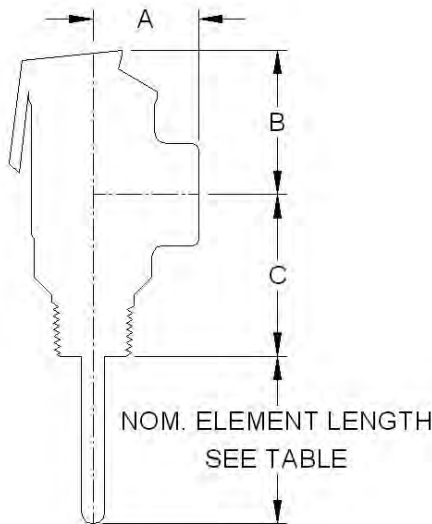

The Apollo® 18C-500 Series bronze automatic temperature and pressure relief valves are used for protection of high capacity commercial hot water heaters and storage tanks.

FEATURES

- ASME Section IV Certified Capacity
- 3/4" thru 2" NPT Connections
- CSA Listed and Certified to ANSI Z21.22
- 125 and 150 psig Set Pressures at 210°F max
- Coated Element Protects Against Corrosion
- SS Elements (1-1/2" and 2")
- ASME Section IV Heating Boilers
- Canadian Registration Number CSA- 0G1438.6C

CAPACITY

PART NUMBER	SIZE (IN.)	ELEMENT LENGTH (IN.)	INLET TYPE	CSA CAPACITY RATING BTU/HR	*ASME CAP. RATING BTU/HR
18C5113125	3/4"	2.69"	M	185,000	1,619,000
18C5113150	3/4"	2.69"	M	185,000	1,912,000
18C5115125	3/4"	4.38"	M	205,000	1,619,000
18C5115150	3/4"	4.38"	M	205,000	1,912,000
18C5118125	3/4"	7.56"	M	205,000	1,619,000
18C5118150	3/4"	7.56"	M	205,000	1,912,000
18C5123125	3/4"	2.88"	F	185,000	1,619,000
18C5123150	3/4"	2.88"	F	185,000	1,912,000
18C5125125	3/4"	4.56"	F	205,000	1,619,000
18C5125150	3/4"	4.56"	F	205,000	1,912,000
18C5128125	3/4"	7.75"	F	205,000	1,619,000
18C5128150	3/4"	7.75"	F	205,000	1,912,000
18C5213125	1"	3.06"	M	500,000	1,825,000
18C5213150	1"	3.06"	M	500,000	2,155,000
18C5215125	1"	4.75"	M	500,000	1,825,000
18C5215150	1"	4.75"	M	500,000	2,155,000
18C5225125	1"	4.75"	F	750,000	3,070,000
18C5225150	1"	4.75"	F	750,000	3,625,000
18C5228125	1"	8.13"	F	750,000	3,070,000
18C5228150	1"	8.13"	F	750,000	3,625,000
18C5314125	1-1/4" x 1"	3.97"	M	750,000	3,070,000
18C5314150	1-1/4" x 1"	3.97"	M	750,000	3,625,000
18C5424125	1-1/2"	4.13"	F	1,200,000	5,125,000
18C5424150	1-1/2"	4.13"	F	1,200,000	6,050,000
18C5513125	2" x 1-1/2"	3.25"	M	1,200,000	5,125,000
18C5513150	2" x 1-1/2"	3.25"	M	1,200,000	6,050,000

* National Board certified capacity per ASME Section IV-Heating Boilers

AVAILABLE CONFIGURATIONS

MODEL NUMBER	INLET SIZE (IN./MM)	DIMENSIONS (IN./MM)		
		A	B	C
18C511	3/4" M x 3/4" FNPT	1.50	3.47	2.53
	(20)	(40)	(88)	(64)
18C512	3/4" F x 3/4" FNPT	1.50	3.47	2.35
	(20)	(40)	(88)	(60)
18C521	1" M x 1" FNPT	1.56	3.47	2.38
	(25)	(40)	(88)	(60)
18C522	1" F x 1" FNPT	1.56	3.47	2.13
	(25)	(40)	(88)	(54)
18C531	1-1/4" M x 1" FNPT	1.75	4.34	1.91
	(32)	(44)	(110)	(49)
18C542	1-1/2" M x 1-1/2" FNPT	2.47	5.84	1.71
	(40)	(63)	(148)	(43)
18C551	2" M x 1-1/2" FNPT	2.47	5.84	259
	(50)	(63)	(148)	(66)

Special statement regarding T&P Valves and compliance to the Lead Free requirements of the U.S. Safe Drinking Water Act.

Effective January 4th 2014 the SDWA requires that pipes, fittings or fixtures used to convey or dispense potable water must be lead free. Further clarification has been provided by the EPA in a document titled "Summary of the Reduction of Lead In Drinking Water Act and frequently Asked Questions". The latest document can be viewed on our website www.apollovalves.com

FAQ #6 states that water heaters are covered by the Act and must comply. However most water heater OEM's are certifying their heaters as complete assemblies using non-Lead Free T&P valves due to their relatively small wetted surface area.

FAQ #23 acknowledges this and states that replacement parts (including T&P valves) need not be lead free as long as the entire water heater with all installed components overall device would meet the Lead Free requirements of the Act.

**19 SERIES
BRONZE SAFETY VALVE**



A dependable cast bronze high capacity safety valve ideal for use on all types of boilers, piping systems and unfired pressure vessels. This rugged design features top guided alignment for enhanced performance and reliability. Other features include optional metal seating, optional stainless steel wetted trim in all sizes, and a new, more descriptive model numbering system. Flow ratings are National Board certified in accordance with ASME sections I and VIII.

ASME SECTIONS I AND VIII

- Sizes 1/2" thru 2-1/2"
- Factory Set Pressures 5 to 300 psig
- Maximum Temperature: 406°F (Model 19S: 422°F)

APPLICATIONS

- Overpressure Protection of Steam Boilers, Sterilizers, Distillers, Cookers, and Pressure Reducing Stations.
- Pneumatic Conveying Equipment, Air Compressors, Receivers and Dryers. Steam, Air and Gas Accumulators, Pressure Vessels and Pressure Piping Systems.

FEATURES

- Wide Wrenching Hex for Easier, Faster Installations
- Stainless Steel Springs are Standard
- Teflon® PFA Seat Resists Corrosive Boiler Chemicals and Excessive Vibration
- High-Capacity Full Nozzle Design Available in Six Orifice Sizes
- Two Control Rings for Maximum Performance and Adjustability
- Short "Tuned" Blow Down Minimizes Product Loss
- Tapped Body Drain Allows Piping of Condensate Safely Away From Equipment
- Reduced Repair Costs: Soft Seat Easily Replaced
- Registered in all Canadian Provinces Under CSA B51 CRN OG8547.5C

OPTIONS

- Choice of Teflon® or Metal-to-Metal Seating
- Steam Set Pressures to 300 psi @ 422°F (Model 19S, Stainless Steel Trim)
- 316 Stainless Steel Wetted Trim Available for all Sizes
- Anti-Vibration Dampened Lifting Lever
- Oxygen Cleaned
- European Pressure Equipment Directive Compliant Option (CE/PED)

TRIM STYLES

SERIES	19K	19M	19L	19S
Trim	Brass	Brass	SS	SS
Seat	Teflon®	Metal to Metal	Teflon®	Metal to Metal
Max. Set - Steam	250	250	250	300
Max. Set - Air/Gas	300	300	300	300
Max. Temperature	406°F	406°F	406°F	422°F

SEATS

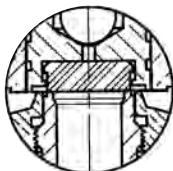

SOFT SEAT
MODEL 19K - BRASS
MODEL 19L - STAINLESS

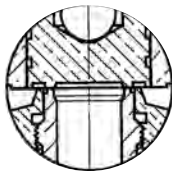

METAL-TO-METAL SEAT
MODEL 19M - BRASS
MODEL 19S - STAINLESS

PART NUMBER MATRIX

19M	D	C	K	165	A
BASE MODEL NUMBER	ORIFICE LETTER	INLET SIZE (IN.) NPT	ASME CODE AND SERVICE	SET PRESSURE IN PSI	SPECIAL OPTIONS
19K - BRASS TRIM/ PFA TEFLON SEAT	D	C - 1/2	A - SECT. I STEAM		A - ANTI-VIBRATION TRIM
19M - BRASS TRIM/METAL SEAT	E	D - 3/4	K - SECT. VIII AIR		CE - CE/PED COMPLIANT
19L - STAINLESS TRIM/ PFA TEFLON SEAT	F	E - 1	L - SECT. VIII STEAM		Q - PERFORMANCE (CALIBRATION) TEST REPORT
19S - STAINLESS TRIM/METAL SEAT	G	F - 1-1/4	N - NON-CODE AIR		X - OXYGEN CLEANING
	H	G - 1-1/2	P - NON-CODE STEAM		*OTHER SUFFIXES - FACTORY ISSUED
	J	H - 2			
		J - 2-1/2			

EXAMPLE:
19K-DCL150 = 19 Series safety valve w/ PFA Teflon seat, D orifice, 1/2" x 3/4", Sect. VII Steam, set @ 150 psi,

**19 SERIES
BRONZE SAFETY VALVE**

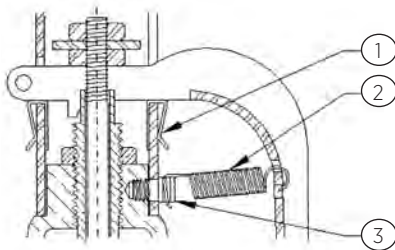
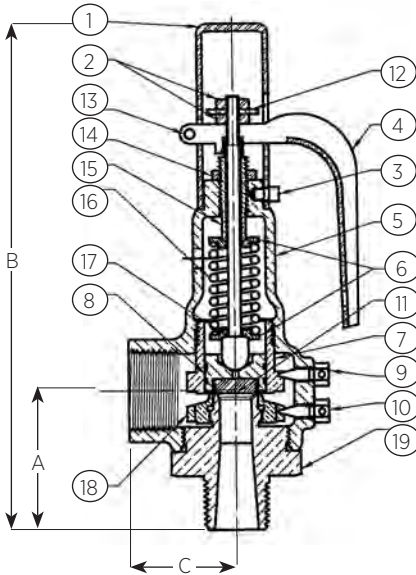

STANDARD MATERIAL LIST

		19K, 19M	19L, 19S
1	Cap	Brass	Brass
2	Stem Nut (2)	Steel, Plated	Steel, Plated
3	Cap Lock Screw	Brass	Brass
4	Lift Lever	Steel - Plated	Steel, Plated
5	Body	Bronze	Bronze
6	Spring Washer (2)	Brass	Brass
7	Guide Ring	Brass	Brass
8	Disc	Brass	Stainless Steel
9	Guide Ring Screw	Brass	Brass
10	Nozzle Ring Screw	Brass	Brass
11	Seat Insert-19K &19L	PFA Teflon*	PFA Teflon*
12	Lift Washer	Steel, Plated	Steel, Plated
13	Lever Pin	Steel, Plated	Steel, Plated
14	Adj. Screw Lock Nut	Steel, Plated	Steel, Plated
15	Adjusting Screw	Brass	Brass
16	Spring	Stainless Steel	Stainless Steel
17	Stem	Stainless Steel	Stainless Steel
18	Nozzle Ring	Brass	Brass
19	Nozzle	Brass	Stainless Steel
-	Nameplate	Stainless Steel	Stainless Steel
-	Seal And Wire	Lead/SS*	Lead/SS*

* Alum/SS on CE models

19 SERIES WITH OPTION "A" ANTI-VIBRATION TRIM

1	FRICION CLIP (4)	Steel, Plated
2	EXTENSION SPRING	Stainless Steel
3	CAP LOCK SCREW	Stainless Steel

Note: Preparation includes threadlocking of all internal threaded connections.

AVAILABLE CONFIGURATIONS

OLD MODEL NUMBER	NEW MODEL NUMBER	ORIFICE LETTER	SIZE (IN./MM) INLET X OUTLET	DIMENSIONS (IN./MM)			WT./EA. (LB./KG)
				A	B	C	
19-202	19*DC	D	1/2 X 3/4	2.21	6.52	1.37	1.6
			15 x 20	56	166	35	.73
19-301	19*DD	D	3/4 X 3/4	2.21	6.52	1.37	1.6
			20 x 20	56	166	35	.73
19-302	19*ED	E	3/4 X 1	2.50	7.16	1.75	2.0
			20 x 25	64	182	44	.91
19-401	19*EE	E	1 X 1	2.64	7.30	1.75	2.2
			25 x 25	67	185	44	1.0
19-402	19*FE	F	1 X 1-1/4	2.95	9.34	2.00	4.1
			25 x 32	75	237	51	1.9
19-501	19*FF	F	1-1/4 X 1-1/4	2.95	9.34	2.00	4.3
			32 x 32	75	237	51	2.0
19-502	19*GF	G	1-1/4 X 1-1/2	3.38	11.01	2.37	7.4
			32 x 40	86	280	60	3.4
19-601	19*GG	G	1-1/2 X 1-1/2	3.38	11.01	2.37	7.6
			40 x 40	86	280	60	3.4
19-602	19*HG	H	1-1/2 X 2	3.63	11.96	2.75	11.5
			40 x 50	92	304	70	5.2
19-701	19*HH	H	2 X 2	3.63	11.96	2.75	11.6
			50 x 50	92	304	70	5.3
	19*JG ¹	J	1-1/2F X 2-1/2	3.80	14.00	3.50	20.0
			40 x 65	97	356	89	9.1
19-702	19*JH	J	2 X 2-1/2	4.06	14.25	3.50	19.9
			50 x 65	103	362	89	9.0
19-801	19*JJ	J	2-1/2 X 2-1/2	4.50	14.68	3.50	20.8
			65 x 65	114	373	89	9.4

* Specify trim letter

¹: Available in bronze trim only, Model 19KJG & 19MJG.

Connections are 1-1/2" FNPT x 2-1/2" FNPT.

ASME SECTION I - STEAM

• Pounds per hour (kilograms per hour) saturated steam @ 3% overpressure. National Board Certified. Ratings are 90% of actual.

US CUSTOMARY UNITS BTU/HR.

ORIFICE LETTER AREA IN. ²	D 0.129	E 0.230	F 0.359	G 0.589	H 0.919	J 1.509
SET PRESSURE PSIG						
15	174	310	484	794	1,240	2,035
20	201	359	561	920	1,435	2,356
25	229	408	637	1,045	1,631	2,677
30	256	457	713	1,170	1,826	2,998
35	284	506	790	1,296	2,022	3,319
40	311	555	866	1,421	2,217	3,641
45	339	604	942	1,546	2,413	3,962
50	366	653	1,019	1,672	2,608	4,283
55	394	702	1,095	1,797	2,804	4,604
60	421	751	1,172	1,922	2,999	4,925
65	448	800	1,248	2,048	3,195	5,246
70	476	849	1,326	2,175	3,394	5,573
75	505	900	1,405	2,304	3,596	5,904
80	533	950	1,483	2,433	3,797	6,234
85	561	1,001	1,562	2,563	3,998	6,565
90	590	1,051	1,641	2,692	4,200	6,896
95	618	1,101	1,719	2,821	4,401	7,226
100	646	1,152	1,798	2,950	4,602	7,557
105	674	1,202	1,877	3,079	4,804	7,888
110	703	1,253	1,955	3,208	5,005	8,218
115	731	1,303	2,034	3,337	5,207	8,549
120	759	1,353	2,113	3,466	5,408	8,880
125	787	1,404	2,191	3,595	5,609	9,210
130	816	1,454	2,270	3,724	5,811	9,541
135	844	1,505	2,349	3,853	6,012	9,872
140	872	1,555	2,427	3,982	6,213	10,202
145	900	1,605	2,506	4,111	6,415	10,533
150	929	1,656	2,585	4,240	6,616	10,864
160	985	1,757	2,742	4,499	7,019	11,525
170	1,042	1,857	2,899	4,757	7,422	12,186
180	1,098	1,958	3,057	5,015	7,824	12,848
190	1,155	2,059	3,214	5,273	8,227	13,509
200	1,211	2,160	3,371	5,531	8,630	14,170
210	1,268	2,261	3,529	5,789	9,033	14,832
220	1,324	2,361	3,686	6,047	9,436	15,493
230	1,381	2,462	3,843	6,305	9,838	16,154
240	1,438	2,563	4,001	6,564	10,241	16,816
250	1,494	2,664	4,158	6,822	10,644	17,477
255	1,522	2,714	4,237	6,951	10,845	17,808
260	1,551	2,765	4,315	7,080	11,047	18,138
265	1,579	2,815	4,394	7,209	11,248	18,469
270	1,607	2,865	4,473	7,338	11,449	18,800
275	1,635	2,916	4,551	7,467	11,651	19,130
280	1,664	2,966	4,630	7,596	11,852	19,461
285	1,692	3,017	4,709	7,725	12,053	19,792
290	1,720	3,067	4,787	7,854	12,255	20,122
295	1,748	3,117	4,866	7,983	12,456	20,453
300	1,777	3,168	4,945	8,112	12,658	20,784
Approx. 1 psi increments	5.7	10.0	15.6	25.8	40.2	66.0

METRIC UNITS Kcal/HR.

ORIFICE LETTER AREA CM. ²	D 0.835	E 1.483	F 2.315	G 3.800	H 5.932	J 9.733
SET PRESSURE BARG						
0.34	-	-	-	-	-	-
0.69	-	-	-	-	-	-
1.1	81	145	226	371	579	951
1.5	96	171	266	437	682	1,120
2	114	203	317	519	811	1,331
2.5	132	235	367	602	940	1,542
3	150	267	417	684	1,068	1,753
3.5	168	299	467	767	1,197	1,964
4	186	331	517	849	1,326	2,175
4.5	204	364	568	932	1,454	2,386
5	222	397	619	1,016	1,586	2,602
5.5	241	430	671	1,101	1,719	2,820
6	259	463	723	1,186	1,851	3,037
6.5	278	496	774	1,271	1,984	3,255
7	296	529	826	1,356	2,116	3,472
7.5	315	562	878	1,440	2,249	3,690
8	334	595	929	1,525	2,381	3,907
8.5	352	628	981	1,610	2,514	4,125
9	371	662	1,033	1,695	2,646	4,342
9.5	389	695	1,085	1,780	2,779	4,559
10	408	728	1,136	1,865	2,911	4,777
10.5	426	761	1,188	1,950	3,044	4,994
11	445	794	1,240	2,035	3,176	5,212
11.5	464	827	1,292	2,120	3,309	5,429
12	482	860	1,343	2,204	3,441	5,647
12.5	501	893	1,395	2,289	3,574	5,864
13	519	927	1,447	2,374	3,706	6,082
13.5	538	960	1,498	2,459	3,839	6,299
14	556	993	1,550	2,544	3,971	6,517
15	594	1,059	1,654	2,714	4,236	6,951
16	631	1,125	1,757	2,884	4,501	7,386
17	668	1,192	1,861	3,053	4,767	7,821
18	705	1,258	1,964	3,223	5,032	8,256
19	742	1,324	2,067	3,393	5,297	8,691
20	779	1,390	2,171	3,563	5,562	9,126
20.7	805	1,437	2,243	3,682	5,747	9,430
Approx. 0.1 barg increments	3.7	6.6	10.3	17.0	26.5	43.5

Note:
Specify model 19S with stainless steel wetted trim for steam settings beyond 250 psig / 17.2 barg.

SAFETY RELIEF VALVES

**19 SERIES
BRONZE SAFETY VALVE**

ASME SECTION VIII - STEAM

• Pounds per hour (kilograms per hour) saturated steam at 10% overpressure. National Board Certified. Ratings are 90% of actual.

US CUSTOMARY UNITS LB./HR.

ORIFICE LETTER AREA IN. ²	D 0.129	E 0.230	F 0.359	G 0.589	H 0.919	J 1.509
SET PRESSURE PSIG						
5*	122	218	340	558	871	1,429
10*	167	298	466	765	1,193	1,958
15	179	320	499	820	1,279	2,100
20	207	369	576	945	1,474	2,421
25	234	418	652	1,070	1,670	2,742
30	262	467	729	1,195	1,865	3,063
35	292	521	813	1,333	2,080	3,416
40	322	574	897	1,471	2,295	3,769
45	352	628	981	1,609	2,510	4,122
50	383	682	1,065	1,747	2,725	4,475
55	413	736	1,149	1,885	2,941	4,828
60	443	790	1,233	2,022	3,156	5,181
65	473	844	1,317	2,160	3,371	5,535
70	503	897	1,401	2,298	3,586	5,888
75	534	951	1,485	2,436	3,801	6,241
80	564	1,005	1,569	2,574	4,016	6,594
85	594	1,059	1,653	2,712	4,231	6,947
90	624	1,113	1,737	2,849	4,446	7,300
95	654	1,167	1,821	2,987	4,661	7,653
100	684	1,220	1,905	3,125	4,876	8,007
105	715	1,274	1,989	3,263	5,091	8,360
110	745	1,328	2,073	3,401	5,306	8,713
115	775	1,382	2,157	3,539	5,521	9,066
120	805	1,436	2,241	3,677	5,736	9,419
125	835	1,489	2,325	3,814	5,951	9,772
130	866	1,543	2,409	3,952	6,167	10,125
135	896	1,597	2,493	4,090	6,382	10,479
140	926	1,651	2,577	4,228	6,597	10,832
145	956	1,705	2,661	4,366	6,812	11,185
150	986	1,759	2,745	4,504	7,027	11,538
155	1,017	1,812	2,829	4,641	7,242	11,891
160	1,047	1,866	2,913	4,779	7,457	12,244
165	1,077	1,920	2,997	4,917	7,672	12,597
170	1,107	1,974	3,081	5,055	7,887	12,951
180	1,167	2,082	3,249	5,331	8,317	13,657
190	1,228	2,189	3,417	5,606	8,747	14,363
200	1,288	2,297	3,585	5,882	9,177	15,069
210	1,349	2,405	3,753	6,158	9,608	15,776
220	1,409	2,512	3,921	6,433	10,038	16,482
230	1,469	2,620	4,089	6,709	10,468	17,188
240	1,530	2,727	4,257	6,985	10,898	17,894
250	1,590	2,835	4,425	7,260	11,328	18,601
255	1,620	2,889	4,509	7,398	11,543	18,954
260	1,651	2,943	4,593	7,536	11,758	19,307
265	1,681	2,997	4,677	7,674	11,973	19,660
270	1,711	3,050	4,761	7,812	12,188	20,013
275	1,741	3,104	4,845	7,950	12,403	20,366
280	1,771	3,158	4,929	8,087	12,618	20,720
285	1,801	3,212	5,013	8,225	12,834	21,073
290	1,832	3,266	5,097	8,363	13,049	21,426
295	1,862	3,320	5,181	8,501	13,264	21,779
300	1,892	3,373	5,265	8,639	13,479	22,132
Approx. 1 psi increments	6.0	10.8	16.8	27.6	43.0	70.6

METRIC UNITS KG/HR.

ORIFICE LETTER AREA CM. ²	D 0.835	E 1.483	F 2.315	G 3.800	H 5.932	J 9.733
SET PRESSURE BARG						
0.34*	55	99	154	253	395	648
0.69*	76	135	211	347	541	888
1.1	84	149	233	382	597	980
1.5	98	175	273	448	700	1,149
2	116	207	323	531	829	1,360
2.5	136	242	378	620	968	1,589
3	156	277	433	711	1,110	1,821
3.5	175	313	489	802	1,251	2,054
4	195	348	544	892	1,393	2,286
4.5	215	384	599	983	1,535	2,518
5	235	419	654	1,074	1,676	2,750
5.5	255	454	709	1,164	1,818	2,982
6	274	490	765	1,255	1,959	3,215
6.5	294	525	820	1,346	2,101	3,447
7	314	561	875	1,436	2,242	3,679
7.5	334	596	930	1,527	2,384	3,911
8	354	631	986	1,618	2,525	4,144
8.5	374	667	1,041	1,708	2,667	4,376
9	393	702	1,096	1,799	2,808	4,608
9.5	413	737	1,151	1,890	2,950	4,840
10	433	773	1,207	1,980	3,091	5,072
10.5	453	808	1,262	2,071	3,233	5,305
11	473	844	1,317	2,162	3,374	5,537
11.5	493	879	1,372	2,252	3,516	5,769
12	512	914	1,428	2,343	3,657	6,001
12.5	532	950	1,483	2,434	3,799	6,234
13	552	985	1,538	2,524	3,941	6,466
13.5	572	1,021	1,593	2,615	4,082	6,698
14	592	1,056	1,649	2,706	4,224	6,930
15	631	1,127	1,759	2,887	4,507	7,395
16	671	1,197	1,870	3,068	4,790	7,859
17	711	1,268	1,980	3,250	5,073	8,324
18	750	1,339	2,091	3,431	5,356	8,788
19	790	1,410	2,201	3,612	5,639	9,253
20	830	1,480	2,312	3,794	5,922	9,717
20.7	857	1,530	2,389	3,920	6,120	10,042
Approx. 0.1 barg increments	4.0	7.1	11.5	18.1	28.3	46.4

Note:
Specify model 19S with stainless steel wetted trim for steam settings beyond 250 psig / 17.2 barg.
*Settings below 15 psi (1.1 barg) are non-ASME code.

SAFETY RELIEF VALVES

**19 SERIES
BRONZE SAFETY VALVE**

ASME SECTION VIII - AIR

• Standard cubic feet per minute (normalized cubic meters per hour) of air at 10% overpressure. National Board Certified. Ratings are 90% of actual.

US CUSTOMARY UNITS SCFM

ORIFICE LETTER AREA IN. ²	D 0.129	E 0.230	F 0.359	G 0.589	H 0.919	J 1.509
SET PRESSURE PSIG						
5*	39	69	108	178	277	455
10*	54	97	151	248	387	635
15	64	114	178	292	455	747
20	74	131	205	336	525	862
25	83	149	232	381	594	976
30	93	166	259	426	664	1,090
35	104	185	289	475	740	1,216
40	115	204	319	524	817	1,342
45	125	224	349	573	894	1,467
50	136	243	379	622	970	1,593
55	147	262	409	671	1,047	1,719
60	158	281	439	720	1,123	1,844
65	168	300	469	769	1,200	1,970
70	179	319	499	818	1,276	2,096
75	190	339	528	867	1,353	2,221
80	201	358	558	916	1,429	2,347
85	211	377	588	965	1,506	2,473
90	222	396	618	1,014	1,583	2,598
95	233	415	648	1,063	1,659	2,724
100	244	434	678	1,112	1,736	2,850
105	254	454	708	1,161	1,812	2,976
110	265	473	738	1,211	1,889	3,101
115	276	492	768	1,260	1,965	3,227
120	287	511	798	1,309	2,042	3,353
125	297	530	828	1,358	2,118	3,478
130	308	549	857	1,407	2,195	3,604
135	319	568	887	1,456	2,271	3,730
140	330	588	917	1,505	2,348	3,855
145	340	607	947	1,554	2,425	3,981
150	351	626	977	1,603	2,501	4,107
160	373	664	1,037	1,701	2,654	4,358
165	383	683	1,067	1,750	2,731	4,484
170	394	703	1,097	1,799	2,807	4,610
180	416	741	1,156	1,897	2,960	4,861
190	437	779	1,216	1,996	3,114	5,112
200	459	818	1,276	2,094	3,267	5,364
210	480	856	1,336	2,192	3,420	5,615
220	502	894	1,396	2,290	3,573	5,867
230	523	932	1,456	2,388	3,726	6,118
240	545	971	1,515	2,486	3,879	6,369
250	566	1,009	1,575	2,584	4,032	6,621
255	577	1,028	1,605	2,633	4,109	6,746
260	587	1,047	1,635	2,682	4,185	6,872
265	598	1,067	1,665	2,731	4,262	6,998
270	609	1,086	1,695	2,781	4,338	7,124
275	620	1,105	1,725	2,830	4,415	7,249
280	630	1,124	1,755	2,879	4,491	7,375
285	641	1,143	1,784	2,928	4,568	7,501
290	652	1,162	1,814	2,977	4,645	7,626
295	663	1,182	1,844	3,026	4,721	7,752
300	673	1,201	1,874	3,075	4,798	7,878
Approx. 1 psi increments	2.1	3.8	6.0	9.8	15.3	25.1

METRIC UNITS Nm³/HR.

ORIFICE LETTER AREA CM. ²	D 0.835	E 1.483	F 2.315	G 3.800	H 5.932	J 9.733
SET PRESSURE BARG						
0.34*	66	118	184	302	471	773
0.69*	92	164	256	421	657	1,078
1.1	112	199	311	510	796	1,306
1.5	131	233	364	598	933	1,531
2	155	276	431	708	1,105	1,813
2.5	181	323	504	827	1,291	2,119
3	207	370	578	948	1,480	2,428
3.5	234	417	651	1,069	1,669	2,738
4	260	464	725	1,190	1,857	3,047
4.5	287	511	799	1,311	2,046	3,357
5	313	559	872	1,431	2,235	3,667
5.5	340	606	946	1,552	2,423	3,976
6	366	653	1,020	1,673	2,612	4,286
6.5	392	700	1,093	1,794	2,801	4,596
7	419	747	1,167	1,915	2,989	4,905
7.5	445	795	1,241	2,036	3,178	5,215
8	472	842	1,314	2,157	3,367	5,524
8.5	498	889	1,388	2,278	3,555	5,834
9	525	936	1,461	2,398	3,744	6,144
9.5	551	983	1,535	2,519	3,933	6,453
10	577	1,030	1,609	2,640	4,122	6,763
10.5	604	1,078	1,682	2,761	4,310	7,072
11	630	1,125	1,756	2,882	4,499	7,382
11.5	657	1,172	1,830	3,003	4,688	7,692
12	683	1,219	1,903	3,124	4,876	8,001
12.5	710	1,266	1,977	3,245	5,065	8,311
13	736	1,313	2,051	3,365	5,254	8,621
13.5	763	1,361	2,124	3,486	5,442	8,930
14	789	1,408	2,198	3,607	5,631	9,240
15	842	1,502	2,345	3,849	6,008	9,859
16	895	1,596	2,493	4,091	6,386	10,478
17	948	1,691	2,640	4,332	6,763	11,097
18	1,000	1,785	2,787	4,574	7,141	11,717
19	1,053	1,879	2,935	4,816	7,518	12,336
20	1,106	1,974	3,082	5,058	7,895	12,955
20.7	1,143	2,040	3,185	5,227	8,160	13,389
Approx. 0.1 barg increments	5.3	9.4	14.7	24.2	37.7	61.9

Note:
To correct for temperature or specific gravities other than air (=1.0), multiply the SCFM from the capacity tables by factor Ksg
*Settings below 15 psi (1.1 barg) are non-ASME code.

SAFETY RELIEF VALVES

29 SERIES

OEM STYLE BRONZE SAFETY VALVE



The Apollo® 29 Series is ideally suited for OEM applications where compact size, dependable performance and maximum economy are required. These rugged safety valves feature a top guided design and patented Teflon® "soft-seat" for dramatically reduced seat leakage. Flow ratings are National Board certified.

ASME SECTIONS I AND VIII

- Sizes 3/8" - 1-1/4" NPT
- Factory Set pressures 30 to 200 psig
- Maximum Temperature: 406°F

APPLICATIONS

- Small to Medium Sized Steam Power Boilers, Sterilizers and Distillers, Air Compressors and Receivers, Pressure Vessels and Pressure Piping Systems

FEATURES

- Stainless Steel Springs are Standard
- PFA Teflon® Seat Resists Corrosive Boiler Chemicals
- Rust-Proofed Steel Stem and Spring Washers
- Lower Control Ring Ensures Short, Consistent Blowdown
- Tapped Body Drain Allows Piping of Condensate Away from Equipment
- Reduced Repair Costs; Soft Seat Easily Replaced
- Registered in all Canadian Provinces Under CSA B51 CRN OG8547.5C

OPTIONS

- 316 Stainless Steel Wetted Trim (29-202 & 29-303 Sizes Only)
- Oxygen Cleaned
- European Pressure Equipment Directive Compliant Option (CE/PED)

STANDARD MATERIAL LIST

1	Cap	Bronze or Brass
2	Stem	Steel, Plated
3	Lift Washer	Steel, Plated
4	Lift Lever	Steel, Plated
5	Adjusting Screw	Brass
6	Lock Nut	Brass
7	Body	Bronze
8	Nameplate	Stainless Steel
9	Drive Screws	Stainless Steel
10	Set Screw	Brass
11	Blowdown Ring	Brass
12	Nozzle*	Brass/Stainless
13	Seat Insert	Teflon® PFA
14	Disc Holder	Brass
15	Lower Washer	Steel, Plated
16	Seat Retainer*	Brass/Stainless
17	Stem Pin	Stainless Steel
18	Spring	Stainless Steel
19	Upper Washer	Steel, Plated
20	Lock Screw	Steel, Plated
21	Lever Pin	Steel, Plated
22	Retaining Ring	Stainless Steel
-	Seal & Wire	Lead/Steel

*Optional stainless steel wetted trim for models 29-202XXL and 29-302XXL. Items 12 & 16 are type 316 stainless steel.

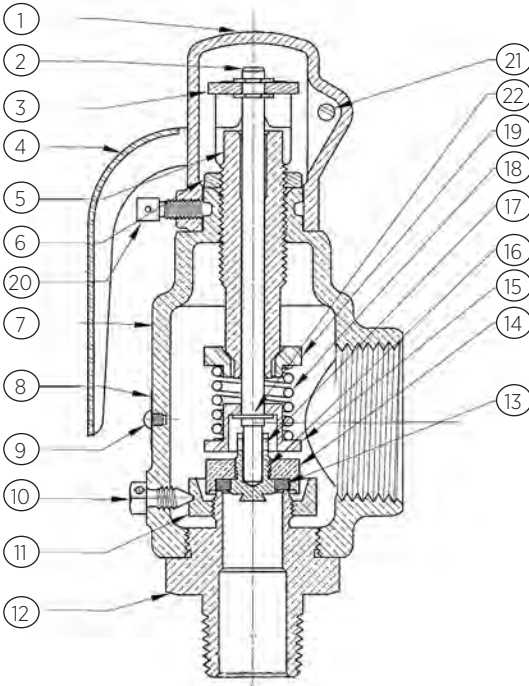

SAFETY RELIEF VALVES

29 SERIES
OEM STYLE BRONZE SAFETY VALVE

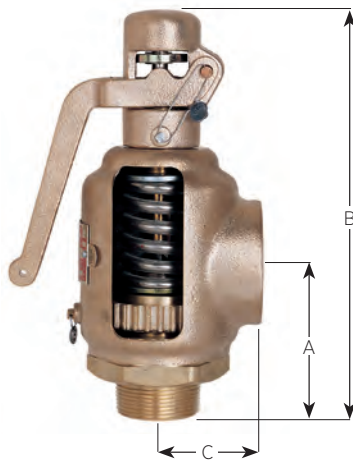

AVAILABLE CONFIGURATIONS

MODEL NUMBER	SIZE (IN./MM)		WT./EA. (LB./KG)	DIMENSIONS (IN./MM)		
	INLET	OUTLET		A	B	C
29-102	3/8	1	1.30	2.12	5.40	1.25
	10	25	.59	53	137	31
29-202	1/2	1	1.33	2.12	5.40	1.25
	15	25	.60	53	137	31
29-302	3/4	1	1.90	2.12	5.40	1.25
	20	25	.86	53	137	31
29-303	3/4	1-1/4	3.43	2.75	7.25	1.69
	20	32	1.55	69	184	42
29-402	1	1-1/4	3.43	2.75	7.25	1.69
	25	32	1.55	69	184	42
29-501	1-1/4	1-1/4	3.48	2.75	7.25	1.69
	32	32	1.58	69	184	42

PART NUMBER MATRIX

29	202	A	100	A
BASE MODEL NUMBER	INLET X OUTLET NPT	ASME CODE & SERVICE	SET PRESSURE (PSI)	SPECIAL OPTIONS
BRONZE WITH BRASS TRIM AND TEFLON® SOFT SEAT	102 - 3/8 X 1	A - SEC I STEAM	SET PRESSURE (PSIG)	S - STAINLESS STEEL WETTED TRIM (MODELS 29-202 & 29-303 ONLY)
	202 - 1/2 X 1	K - SEC VIII AIR	(RANGE 30-200 PSIG)	
	302 - 3/4 X 1	L - SEC VIII STEAM		C - CE/PED
	303 - 3/4 X 1-1/4			Q - PERFORMANCE (CALIBRATION) TEST REPORTS
	402 - 1 X 1-1/4			*OTHER SUFFIXES - FACTORY ISSUED
	501 - 1-1/4 X 1-1/4			

**Not all configurations available together*

EXAMPLE:
 29 202 A100 = 1/2" x 1" 29 Series set @ 100 psig, ASME Section I "V" Steam
 29 202 L40 = 1/2" x 1" 29 Series set @ 40 psig, ASME Section VIII "UV" Steam
 29 303 K200 S = 3/4" x 1-1/4" 29 Series set @ 200 psig, ASME Section VIII "UV" Air, Stainless Steel Wetted Trim

SAFETY RELIEF VALVES



29 SERIES
BRONZE SAFETY

ASME SECTION I - STEAM

• Pounds per hour (kilograms per hour) saturated steam at 3% overpressure. National Board Certified. Ratings are 90% of actual.

US CUSTOMARY UNITS LB./HR.

MODEL NO. SEAT DIA. (IN.)	29-102, 29-202, 29-302 0.500	29-303, 29-402, 29-501 0.737
SET PRESSURE PSIG		
30	164	330
35	182	367
40	201	405
45	220	442
50	238	479
55	257	517
60	275	554
65	294	591
70	312	628
75	331	664
80	349	702
85	368	739
90	386	777
95	405	814
100	423	851
105	442	888
110	460	925
115	479	963
120	497	1,000
125	516	1,036
130	534	1,074
135	553	1,112
140	571	1,149
145	590	1,186
150	608	1,223
155	627	1,261
160	645	1,298
165	664	1,335
170	683	1,372
175	701	1,409
180	720	1,447
185	738	1,484
190	757	1,521
195	775	1,558
200	794	1,596
Approx. 1 psi increments	3.7	7.4

METRIC UNITS KG/HR.

MODEL NO. SEAT DIA. (MM)	29-102, 29-202, 29-302 12.70	29-303, 29-402, 29-501 18.72
SET PRESSURE BARG		
2.1	77	155
2.5	86	174
3	98	197
3.5	110	221
4	122	245
4.5	134	269
5	146	293
5.5	158	318
6	170	342
6.5	182	367
7	195	391
7.5	207	416
8	219	440
8.5	231	465
9	243	489
9.5	255	514
10	268	538
10.5	280	563
11	292	587
11.5	304	612
12	316	636
12.5	329	661
13	341	685
13.5	353	710
13.8	360	724
Approx. 0.1 barg increments	2.44	4.9

SAFETY RELIEF VALVES



29 SERIES
BRONZE SAFETY

ASME SECTION VIII - STEAM

• Pounds per hour (kilograms per hour) saturated steam at 10% overpressure. National Board Certified. Ratings are 90% of actual.

US CUSTOMARY UNITS LB./HR.

MODEL NO. SEAT DIA. (IN.)	29-102, 29-202, 29-302 0.500	29-303, 29-402, 29-501 0.737
SET PRESSURE PSIG		
30	164	330
35	182	367
40	201	405
45	220	442
50	238	479
55	257	517
60	275	554
65	294	591
70	312	628
75	331	664
80	349	702
85	368	739
90	386	777
95	405	814
100	423	851
105	442	888
110	460	925
115	479	963
120	497	1,000
125	516	1,036
130	534	1,074
135	553	1,112
140	571	1,149
145	590	1,186
150	608	1,223
155	627	1,261
160	645	1,298
165	664	1,335
170	683	1,372
175	701	1,409
180	720	1,447
185	738	1,484
190	757	1,521
195	775	1,558
200	794	1,596
Approx. 1 psi increments	3.7	7.4

METRIC UNITS KG/HR.

MODEL NO. SEAT DIA. (MM)	29-102, 29-202, 29-302 12.70	29-303, 29-402, 29-501 18.72
SET PRESSURE BARG		
2.1	79	158
2.5	89	179
3	102	205
3.5	115	231
4	128	257
4.5	141	284
5	154	310
5.5	167	336
6	180	362
6.5	193	388
7	206	414
7.5	219	441
8	232	467
8.5	245	493
9	258	519
9.5	271	545
10	284	571
10.5	297	598
11	310	624
11.5	323	650
12	336	676
12.5	349	702
13	362	728
13.5	375	755
13.8	383	770
Approx. 0.1 barg increments	2.6	5.22

SAFETY RELIEF VALVES



29 SERIES

BRONZE SAFETY

ASME SECTION VIII - AIR

• Standard cubic feet per minute (normalized cubic meters per hour) of air at 10% overpressure. National Board Certified. Ratings are 90% of actual.

US CUSTOMARY UNITS SCFM

MODEL NO. SEAT DIA. (IN.)	29-102, 29-202, 29-302 0.500	29-303, 29-402, 29-501 0.737
SET PRESSURE PSIG		
30	61	123
35	68	137
40	75	151
45	82	165
50	89	180
55	96	193
60	103	208
65	110	222
70	117	236
75	124	250
80	131	264
85	138	278
90	145	292
95	152	307
100	159	321
105	166	335
110	173	349
115	180	363
120	187	378
125	194	392
130	201	406
135	208	420
140	215	434
145	222	448
150	229	463
155	236	477
160	243	491
165	250	505
170	257	519
175	265	533
180	272	547
185	279	562
190	286	576
195	293	590
200	300	604
Approx. 1 psi increments		
	1.4	2.8

METRIC UNITS Nm³./HR.

MODEL NO. SEAT DIA. (MM)	29-102, 29-202, 29-302 12.70	29-303, 29-402, 29-501 18.72
SET PRESSURE BARG		
2.1	105	210
2.5	118	238
3	136	273
3.5	153	308
4	170	342
4.5	188	377
5	205	412
5.5	222	447
6	240	482
6.5	257	516
7	274	551
7.5	291	586
8	309	621
8.5	326	655
9	343	690
9.5	361	725
10	378	760
10.5	395	795
11	413	829
11.5	430	864
12	447	899
12.5	464	934
13	482	969
13.5	499	1,003
13.8	509	1,024
Approx. 0.1 barg increments		
	3.46	6.96

SAFETY RELIEF VALVES

119 SERIES
CAST IRON FLANGED SAFETY VALVE



These flanged, heavy duty and high capacity safety valves are ideal for use on all types of boilers, pressure vessels and pressure piping systems. These ruggedly built valves offer you a cost-saving alternative to conventional steel bodied valves — without compromising quality or performance. These valves feature a top guided design and two control rings to ensure seat tightness, repeatable performance and extended service life. Flow ratings are National Board certified.

ASME SECTIONS I AND VIII

- Set Pressures to 250 psig @ 450°F max
- Flanged Inlet Sizes 1-1/2" thru 6" ANSI 250 lb.
- Threaded Inlet Sizes 2" thru 3" FNPT

APPLICATIONS

- Overpressure Protection of Steam Boilers, Deaerators, Accumulators, Pressure Reducing Stations and Pressure Piping Systems
- Pneumatic Conveying Equipment, Air and Gas Compressors, Receivers and Dryers. Per ASME Code, Cast Iron Safety Relief Valves Must Not be Used for Lethal or Flammable Fluid Service

FEATURES

- Metal-to-Metal Seating, Lapped to Optical Flatness
- High-Capacity Semi-Nozzle Design Available in 8 Orifice Sizes
- Stainless Steel Wetted Trim is Standard
- Two Control Rings Assure Maximum Performance and Dependability
- Designed for New Installations and Replacement of Existing Valves (High Flow Rates and Face-to-Face Dimensions Enable Direct Replacement of Most Competitive Models)
- Designed for Ease of Service or Repair
- Ductile Iron Caps, Forks and Levers for Added Durability
- Registered in all Canadian Provinces Under CSA B51, CRN OG8547.5C
- **Complies with Steel Procurement Act**
- **Made in USA**

OPTIONS

- Drip Pan Elbows for Discharge Piping
- European Pressure Equipment Directive Compliant Option (CE/PED)

PART NUMBER MATRIX

119	K	H	C	A	MAA	0150	Q
SERIES NUMBER	ORIFICE LETTER	INLET (IN.)	CONNECTION	SERVICE	SPECIAL OPTIONS	SET PRESSURE	SUFFIX
119 - STAINLESS STEEL WETTED TRIM	THE ORIFICE LETTER FROM THE CAPACITY CHART (E36-E-39)	G - 1-1/2	A - FNPT X FNPT	A - SEC I STEAM	FACTORY ISSUED LETTERS/NUMBERS (MAA DEFAULT)	SET PRESSURE, PSIG (4 DIGITS)	Q - PERFORMANCE (CALIBRATION) TEST REPORTS
		H - 2	C - 250# X FNPT	K - SEC VIII AIR			
		J - 2-1/2	D - 250# X 125#	L - SEC VIII STEAM	MCE - CE/PED		
		K - 3		N - NON CODE AIR			
		M - 4		P - NON CODE STEAM			
		P - 6					

EXAMPLE:
 119 KHC A MAA 0150 = 2" "K" 3" ASME Section I Steam, set @ 150 psig with flanged inlet
 119 QPD L MAA 0025 = 6" "K" 8" ASME Section VIII Steam, set @ 25 psig with flanged inlet

SAFETY RELIEF VALVES

**119 SERIES
CAST IRON FLANGED SAFETY VALVE**

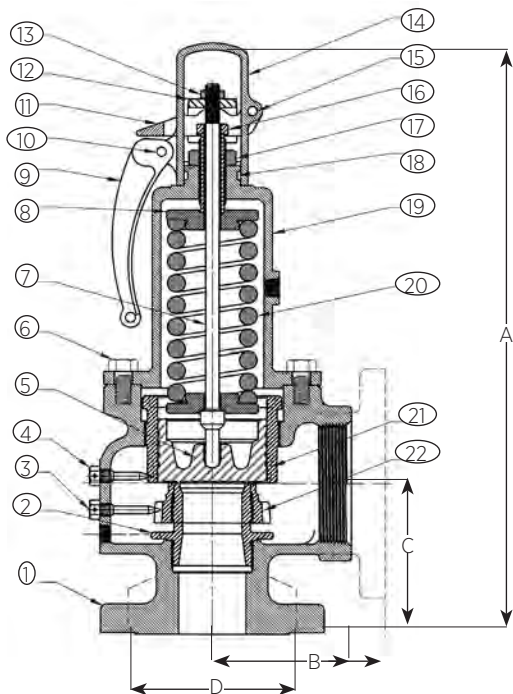

STANDARD MATERIAL LIST

1	BODY	Gray Iron
2	NOZZLE	Stainless Steel
3	NOZZLE RING SCREW	Brass
4	GUIDE RING SCREW	Brass
5	DISC	Stainless Steel
6	BONNET BOLT	Steel, Plated
7	STEM	Steel, Plated
8	SPRING WASHER	Steel, Plated
9	TEST LEVER	Ductile Iron
10	CLEVIS PIN	Steel, Plated
11	LIFTING FORK	Ductile Iron
12	STEM NUT	Steel, Plated
13	STEM NUT LOCK NUT	Steel, Plated
14	LIFTING CAP	Ductile Iron
15	CLEVIS PIN	Steel (Plated)
16	ADJUSTING SCREW	Brass
17	LOCK NUT	Steel, Plated
18	LIFT CAP LOCKSCREW	Steel, Plated
19	BONNET	Gray Iron
20	SPRING	Steel, Plated or SS
21	DISC GUIDE	Brass or Bronze
22	NOZZLE RING	Brass or Bronze
-	NAMEPLATE	Aluminum
-	SEAL AND WIRE	Lead/Steel
-	SEAL AND WIRE (CE)	Aluminum/SS

AVAILABLE CONFIGURATIONS

MODEL NUMBER	SIZE (IN./MM) INLET X OUTLET	ORIFICE SIZE	DIMENSIONS (IN./MM)			HEX FLAT D (IN./MM)	WEIGHT (LB./KG)
			A	B	C		
119 JGC	1-1/2 250# X 2-1/2 FNPT	J	15	4	4.31		35
	DN40 x DN65		381	101	109		15.8
119 KHC	2 250# X 3 FNPT	K	16	4	4.63		36
	DN50 x DN80		406	101	109		16.3
119 KHA	2 FNPT X 3 FNPT	K	16	4	4.63	3.75	37
	DN50 x DN80		406	101	109	95	16.7
119 KJC	2-1/2 250# X 3 FNPT	K	16	4	4.63		41
	DN65 x DN80		406	101	109		18.6
119 KKC	3 250# X 3 FNPT	K	16	4	4.63		45
	DN80 x DN80		406	101	109		20.5
119 LJC	2-1/2 250# X 4 FNPT	L	22	5.13	5.63		84
	DN65 x DN100		558	130	143		38.1
119 LJA	2-1/2 FNPT X 4 FNPT	L	22	5.13	5.63	5.38	81
	DN65 x DN100		558	130	143	136	36.7
119 LKC	3 250# X 4 FNPT	L	22	5.13	5.63		85
	DN80 x DN100		558	130	143		38.5
119 LMC	4 250# X 4 FNPT	L	22	5.13	5.63		90
	DN100 x DN100		558	130	143		40.9
119 MKA	3 FNPT X 4 FNPT	M	22	5.13	5.63	5.38	80
	DN80 x DN100		558	130	143	136	36.2
119 MKC	3 250# X 4 FNPT	M	22	5.13	5.63		87
	DN80 x DN100		558	130	143		39.4
119 MMC	4 250# X 4 FNPT	M	22	5.13	5.63		95
	DN100 x DN100		558	130	143		43.2
119 NMD	4 250# X 6 125#	N	28	7.25	6.75		210
	DN100 x DN150		711	184	171		95.2
119 PMD	4 250# X 6 125#	P	28	7.25	6.75		215
	DN100 x DN150		711	184	171		97.5
119 QPD	6 250# X 8 125#	Q	42	10	9.25		530
	DN150 x DN200		1066	254	234		240.4
119 RPD	6 250# X 8 125#	R	42	10	9.25		530
	DN150 x DN200		1066	254	234		240.4

119 SERIES

CAST IRON FLANGED SAFETY VALVE

ASME SECTION I - STEAM

• Pounds per hour (kilograms per hour) saturated steam at 3% overpressure. National Board Certified. Ratings are 90% of actual.

US CUSTOMARY UNITS LB./HR.

ORIFICE LETTER AREA IN. ²	J 1.358	K 1.926	L 2.99	M 3.774	N 4.55	P 6.692	Q 11.593	R 16.786
SET PRESSURE PSIG								
15	1,947	2,761	4,286	5,410	6,522	9,592	16,617	24,061
20	2,254	3,196	4,962	6,263	7,551	11,105	19,238	27,856
25	2,561	3,632	5,638	7,116	8,579	12,618	21,859	31,651
30	2,868	4,067	6,314	7,969	9,608	14,131	24,480	35,446
35	3,175	4,502	6,990	8,823	10,637	15,644	27,101	39,241
40	3,482	4,938	7,666	9,676	11,665	17,157	29,722	43,036
45	3,789	5,373	8,342	10,529	12,694	18,670	32,343	46,831
50	4,096	5,809	9,018	11,382	13,723	20,183	34,964	50,626
55	4,403	6,244	9,694	12,236	14,751	21,696	37,585	54,421
60	4,710	6,680	10,370	13,089	15,780	23,209	40,206	58,216
65	5,017	7,115	11,046	13,942	16,809	24,722	42,827	62,011
70	5,330	7,559	11,735	14,812	17,858	26,265	45,501	65,882
75	5,646	8,008	12,432	15,691	18,918	27,823	48,200	69,791
80	5,962	8,456	13,128	16,570	19,977	29,382	50,900	73,700
85	6,279	8,905	13,824	17,449	21,037	30,940	53,600	77,609
90	6,595	9,353	14,520	18,328	22,096	32,498	56,299	81,518
95	6,911	9,802	15,217	19,207	23,156	34,057	58,999	85,427
100	7,227	10,250	15,913	20,085	24,215	35,615	61,698	89,336
105	7,544	10,699	16,609	20,964	25,275	37,173	64,398	93,245
110	7,860	11,147	17,305	21,843	26,334	38,732	67,098	97,154
115	8,176	11,596	18,002	22,722	27,394	40,290	69,797	101,063
120	8,492	12,044	18,698	23,601	28,453	41,848	72,497	104,971
125	8,809	12,493	19,394	24,480	29,513	43,407	75,197	108,880
130	9,125	12,941	20,091	25,358	30,573	44,965	77,896	112,789
135	9,441	13,390	20,787	26,237	31,632	46,524	80,596	116,698
140	9,757	13,838	21,483	27,116	32,692	48,082	83,295	120,607
145	10,073	14,287	22,179	27,995	33,751	49,640	85,995	124,516
150	10,390	14,735	22,876	28,874	34,811	51,199	88,695	128,425
155	10,706	15,184	23,572	29,753	35,870	52,757	91,394	132,334
160	11,022	15,632	24,268	30,631	36,930	54,315	94,094	136,243
165	11,338	16,081	24,964	31,510	37,989	55,874	96,794	140,152
170	11,655	16,529	25,661	32,389	39,049	57,432	99,493	144,061
175	11,971	16,978	26,357	33,268	40,108	58,990	102,193	147,969
180	12,287	17,426	27,053	34,147	41,168	60,549	104,893	151,878
185	12,603	17,875	27,750	35,026	42,228	62,107	107,592	155,787
190	12,920	18,323	28,446	35,905	43,287	63,665	110,292	159,696
195	13,236	18,772	29,142	36,783	44,347	65,224	112,991	163,605
200	13,552	19,220	29,838	37,662	45,406	66,782	115,691	167,514
205	13,868	19,669	30,535	38,541	46,466	68,340	118,391	171,423
210	14,184	20,117	31,231	39,420	47,525	69,899	121,090	175,332
215	14,501	20,566	31,927	40,299	48,585	71,457	123,790	179,241
220	14,817	21,014	32,623	41,178	49,644	73,015	126,490	183,150
225	15,133	21,463	33,320	42,056	50,704	74,574	129,189	187,059
230	15,449	21,911	34,016	42,935	51,764	76,132	131,889	190,968
235	15,766	22,360	34,712	43,814	52,823	77,691	134,589	194,876
240	16,082	22,808	35,409	44,693	53,883	79,249	137,288	198,785
245	16,398	23,257	36,105	45,572	54,942	80,807	139,988	202,694
250	16,714	23,705	36,801	46,451	56,002	82,366	142,687	206,603
Approx. 1 psi Increments	63	90	139	176	212	312	540	782

METRIC UNITS KG/HR.

ORIFICE LETTER AREA CM. ²	J 8.762	K 12.426	L 19.287	M 24.347	N 29.357	P 43.174	Q 74.795	R 108.294
SET PRESSURE BARG								
1.1	910	1,290	2,002	2,527	3,048	4,482	7,764	11,242
1.5	1,071	1,519	2,358	2,976	3,589	5,278	9,144	13,239
2	1,273	1,806	2,803	3,538	4,266	6,274	10,868	15,736
2.5	1,475	2,092	3,247	4,099	4,943	7,269	12,593	18,233
3	1,677	2,379	3,692	4,660	5,619	8,264	14,317	20,729
3.5	1,879	2,665	4,137	5,222	6,296	9,260	16,041	23,226
4	2,081	2,952	4,581	5,783	6,973	10,255	17,766	25,723
4.5	2,283	3,238	5,026	6,344	7,650	11,250	19,490	28,219
5	2,490	3,531	5,481	6,919	8,343	12,270	21,256	30,776
5.5	2,698	3,827	5,939	7,497	9,040	13,295	23,032	33,348
6	2,906	4,122	6,397	8,075	9,737	14,320	24,808	35,919
6.5	3,114	4,417	6,855	8,653	10,434	15,345	26,584	38,491
7	3,322	4,712	7,313	9,232	11,131	16,371	28,360	41,062
7.5	3,530	5,007	7,771	9,810	11,828	17,396	30,136	43,634
8	3,738	5,302	8,229	10,388	12,526	18,421	31,912	46,205
8.5	3,947	5,597	8,687	10,966	13,223	19,446	33,689	48,777
9	4,155	5,892	9,145	11,544	13,920	20,471	35,465	51,349
9.5	4,363	6,187	9,603	12,122	14,617	21,497	37,241	53,920
10	4,571	6,482	10,061	12,700	15,314	22,522	39,017	56,492
10.5	4,779	6,777	10,519	13,279	16,011	23,547	40,793	59,063
11	4,987	7,072	10,977	13,857	16,708	24,572	42,569	61,635
11.5	5,195	7,367	11,435	14,435	17,405	25,598	44,345	64,206
12	5,403	7,662	11,893	15,013	18,102	26,623	46,121	66,778
12.5	5,611	7,958	12,351	15,591	18,800	27,648	47,897	69,349
13	5,819	8,253	12,809	16,169	19,497	28,673	49,673	71,921
13.5	6,027	8,548	13,267	16,747	20,194	29,698	51,449	74,492
14	6,235	8,843	13,725	17,325	20,891	30,724	53,225	77,064
15	6,651	9,433	14,641	18,482	22,285	32,774	56,777	82,207
16	7,068	10,023	15,557	19,638	23,679	34,824	60,330	87,350
17	7,484	10,613	16,473	20,794	25,073	36,875	63,882	92,493
Approx 0.1 barg Increments	41.6	59.0	91.6	115.6	139.4	205.0	355.2	514.3

SAFETY RELIEF VALVES

**119 SERIES
CAST IRON FLANGED SAFETY**

ASME SECTION VIII - STEAM

• Pounds per hour (kilograms per hour) saturated steam at 10% overpressure. National Board Certified. Ratings are 90% of actual.

US CUSTOMARY UNITS LB./HR.

ORIFICE LETTER AREA IN. ²	J 1.358	K 1.926	L 2.99	M 3.774	N 4.55	P 6.692	Q 11.593	R 16.786
SET PRESSURE PSIG								
5*	1,312	1,860	2,888	3,645	4,395	6,464	11,198	16,213
10*	1,798	2,550	3,957	4,995	6,023	8,859	15,346	22,220
15	2,008	2,848	4,421	5,580	6,728	9,895	17,141	24,820
20	2,315	3,283	5,097	6,433	7,756	11,408	19,762	28,615
25	2,622	3,719	5,773	7,287	8,785	12,921	22,383	32,410
30	2,929	4,154	6,449	8,140	9,814	14,434	25,004	36,205
35	3,267	4,633	7,193	9,079	10,945	16,098	27,887	40,379
40	3,604	5,112	7,936	10,017	12,077	17,762	30,771	44,554
45	3,942	5,591	8,680	10,956	13,208	19,426	33,654	48,729
50	4,280	6,070	9,423	11,894	14,340	21,091	36,537	52,903
55	4,618	6,549	10,167	12,833	15,471	22,755	39,420	57,078
60	4,955	7,028	10,911	13,771	16,603	24,419	42,303	61,252
65	5,293	7,507	11,654	14,710	17,735	26,083	45,186	65,427
70	5,631	7,986	12,398	15,649	18,866	27,748	48,069	69,601
75	5,969	8,465	13,141	16,587	19,998	29,412	50,952	73,776
80	6,306	8,944	13,885	17,526	21,129	31,076	53,835	77,951
85	6,644	9,423	14,629	18,464	22,261	32,740	56,719	82,125
90	6,982	9,902	15,372	19,403	23,392	34,405	59,602	86,300
95	7,319	10,381	16,116	20,341	24,524	36,069	62,485	90,474
100	7,657	10,860	16,859	21,280	25,655	37,733	65,368	94,649
105	7,995	11,339	17,603	22,218	26,787	39,397	68,251	98,823
110	8,333	11,818	18,346	23,157	27,919	41,062	71,134	102,998
115	8,670	12,297	19,090	24,096	29,050	42,726	74,017	107,173
120	9,008	12,776	19,834	25,034	30,182	44,390	76,900	111,347
125	9,346	13,255	20,577	25,973	31,313	46,055	79,783	115,522
130	9,684	13,734	21,321	26,911	32,445	47,719	82,666	119,696
135	10,021	14,213	22,064	27,850	33,576	49,383	85,550	123,871
140	10,359	14,692	22,808	28,788	34,708	51,047	88,433	128,045
145	10,697	15,171	23,552	29,727	35,839	52,712	91,316	132,220
150	11,034	15,650	24,295	30,666	36,971	54,376	94,199	136,395
155	11,372	16,129	25,039	31,604	38,103	56,040	97,082	140,569
160	11,710	16,608	25,782	32,543	39,234	57,704	99,965	144,744
165	12,048	17,087	26,526	33,481	40,366	59,369	102,848	148,918
170	12,385	17,566	27,270	34,420	41,497	61,033	105,731	153,093
175	12,723	18,045	28,013	35,358	42,629	62,697	108,614	157,267
180	13,061	18,524	28,757	36,297	43,760	64,361	111,497	161,442
185	13,399	19,003	29,500	37,236	44,892	66,026	114,381	165,617
190	13,736	19,482	30,244	38,174	46,023	67,690	117,264	169,791
195	14,074	19,961	30,988	39,113	47,155	69,354	120,147	173,966
200	14,412	20,440	31,731	40,051	48,287	71,018	123,030	178,140
205	14,749	20,919	32,475	40,990	49,418	72,683	125,913	182,315
210	15,087	21,398	33,218	41,928	50,550	74,347	128,796	186,489
215	15,425	21,876	33,962	42,867	51,681	76,011	131,679	190,664
220	15,763	22,355	34,706	43,806	52,813	77,675	134,562	194,839
225	16,100	22,834	35,449	44,744	53,944	79,340	137,445	199,013
230	16,438	23,313	36,193	45,683	55,076	81,004	140,329	203,188
235	16,776	23,792	36,936	46,621	56,207	82,668	143,212	207,362
240	17,113	24,271	37,680	47,560	57,339	84,332	146,095	211,537
245	17,451	24,750	38,424	48,498	58,471	85,997	148,978	215,711
250	17,789	25,229	39,167	49,437	59,602	87,661	151,861	219,886
Approx. 1 psi Increment	68	96	149	188	226	333	577	835

*Settings below 15 psi (1.1 barg) are non-ASME code.

METRIC UNITS KG/HR.

ORIFICE LETTER AREA CM. ²	J 8.762	K 12.426	L 19.287	M 24.347	N 29.357	P 43.174	Q 74.795	R 108.294
SET PRESSURE BARG								
.34*	590	836	1,298	1,639	1,976	2,906	5,034	7,289
.69*	822	1,165	1,809	2,283	2,753	4,049	7,014	10,155
1.1	937	1,329	2,064	2,605	3,141	4,619	8,002	11,586
1.5	1,099	1,559	2,419	3,054	3,682	5,415	9,382	13,584
2	1,301	1,845	2,864	3,615	4,359	6,411	11,106	16,080
2.5	1,520	2,156	3,347	4,225	5,094	7,492	12,979	18,792
3	1,743	2,471	3,836	4,842	5,839	8,587	14,876	21,539
3.5	1,965	2,787	4,325	5,460	6,583	9,682	16,773	24,285
4	2,187	3,102	4,814	6,077	7,328	10,777	18,670	27,031
4.5	2,409	3,417	5,303	6,695	8,072	11,872	20,566	29,778
5	2,632	3,732	5,793	7,312	8,817	12,967	22,463	32,524
5.5	2,854	4,047	6,282	7,929	9,561	14,061	24,360	35,270
6	3,076	4,362	6,771	8,547	10,306	15,156	26,257	38,017
6.5	3,298	4,677	7,260	9,164	11,050	16,251	28,153	40,763
7	3,520	4,992	7,749	9,782	11,795	17,346	30,050	43,509
7.5	3,743	5,308	8,238	10,399	12,539	18,441	31,947	46,255
8	3,965	5,623	8,727	11,017	13,284	19,536	33,844	49,002
8.5	4,187	5,938	9,216	11,634	14,028	20,631	35,741	51,748
9	4,409	6,253	9,706	12,251	14,773	21,726	37,637	54,494
9.5	4,631	6,568	10,195	12,869	15,517	22,820	39,534	57,241
10	4,854	6,883	10,684	13,486	16,262	23,915	41,431	59,987
10.5	5,076	7,198	11,173	14,104	17,006	25,010	43,328	62,733
11	5,298	7,513	11,662	14,721	17,750	26,105	45,224	65,480
11.5	5,520	7,829	12,151	15,338	18,495	27,200	47,121	68,226
12	5,742	8,144	12,640	15,956	19,239	28,295	49,018	70,972
12.5	5,965	8,459	13,129	16,573	19,984	29,390	50,915	73,718
13	6,187	8,774	13,618	17,191	20,728	30,485	52,811	76,465
13.5	6,409	9,089	14,108	17,808	21,473	31,580	54,708	79,211
14	6,631	9,404	14,597	18,426	22,217	32,674	56,605	81,957
15	7,076	10,034	15,575	19,660	23,706	34,864	60,399	87,450
16	7,520	10,665	16,553	20,895	25,195	37,054	64,192	92,943
17	7,964	11,295	17,531	22,130	26,684	39,244	67,986	98,435
Approx. 0.1 barg Increment	44.4	63.0	97.8	123.5	148.9	219.0	379.4	549.3

**119 SERIES
CAST IRON FLANGED SAFETY**

ASME SECTION VIII - AIR

• Standard cubic feet per minute (normalized cubic meters per hour) of air at 10% overpressure. National Board Certified. Ratings are 90% of actual.

US CUSTOMARY UNITS SCFM

ORIFICE LETTER AREA IN. ²	J 1.358	K 1.926	L 2.99	M 3.774	N 4.55	P 6.692	Q 11.593	R 16.786
SET PRESSURE PSIG								
5*	418	592	919	1,160	1,399	2,058	3,565	5,161
10*	583	826	1,282	1,619	1,952	2,870	4,973	7,200
15	715	1,014	1,574	1,986	2,395	3,522	6,101	8,834
20	824	1,169	1,814	2,290	2,761	4,060	7,034	10,185
25	933	1,324	2,055	2,594	3,127	4,599	7,967	11,536
30	1,043	1,479	2,295	2,897	3,493	5,138	8,900	12,887
35	1,163	1,649	2,560	3,231	3,896	5,730	9,926	14,373
40	1,283	1,820	2,825	3,566	4,299	6,322	10,953	15,859
45	1,403	1,990	3,089	3,900	4,701	6,915	11,979	17,345
50	1,523	2,161	3,354	4,234	5,104	7,507	13,005	18,830
55	1,644	2,331	3,619	4,568	5,507	8,099	14,031	20,316
60	1,764	2,502	3,884	4,902	5,910	8,692	15,057	21,802
65	1,884	2,672	4,148	5,236	6,312	9,284	16,084	23,288
70	2,004	2,843	4,413	5,570	6,715	9,877	17,110	24,774
75	2,124	3,013	4,678	5,904	7,118	10,469	18,136	26,260
80	2,245	3,184	4,942	6,238	7,521	11,061	19,162	27,746
85	2,365	3,354	5,207	6,572	7,924	11,654	20,188	29,232
90	2,485	3,524	5,472	6,906	8,326	12,246	21,215	30,718
95	2,605	3,695	5,736	7,240	8,729	12,838	22,241	32,204
100	2,726	3,865	6,001	7,574	9,132	13,431	23,267	33,689
105	2,846	4,036	6,266	7,908	9,535	14,023	24,293	35,175
110	2,966	4,206	6,530	8,243	9,937	14,616	25,320	36,661
115	3,086	4,377	6,795	8,577	10,340	15,208	26,346	38,147
120	3,206	4,547	7,060	8,911	10,743	15,800	27,372	39,633
125	3,327	4,718	7,324	9,245	11,146	16,393	28,398	41,119
130	3,447	4,888	7,589	9,579	11,548	16,985	29,424	42,605
135	3,567	5,059	7,854	9,913	11,951	17,577	30,451	44,091
140	3,687	5,229	8,118	10,247	12,354	18,170	31,477	45,577
145	3,807	5,400	8,383	10,581	12,757	18,762	32,503	47,063
150	3,928	5,570	8,648	10,915	13,160	19,355	33,529	48,549
155	4,048	5,741	8,912	11,249	13,562	19,947	34,556	50,034
160	4,168	5,911	9,177	11,583	13,965	20,539	35,582	51,520
165	4,288	6,082	9,442	11,917	14,368	21,132	36,608	53,006
170	4,408	6,252	9,706	12,251	14,771	21,724	37,634	54,492
175	4,529	6,423	9,971	12,586	15,173	22,317	38,660	55,978
180	4,649	6,593	10,236	12,920	15,576	22,909	39,687	57,464
185	4,769	6,764	10,500	13,254	15,979	23,501	40,713	58,950
190	4,889	6,934	10,765	13,588	16,382	24,094	41,739	60,436
195	5,010	7,105	11,030	13,922	16,784	24,686	42,765	61,922
200	5,130	7,275	11,294	14,256	17,187	25,278	43,791	63,408
205	5,250	7,446	11,559	14,590	17,590	25,871	44,818	64,893
210	5,370	7,616	11,824	14,924	17,993	26,463	45,844	66,379
215	5,490	7,787	12,088	15,258	18,396	27,056	46,870	67,865
220	5,611	7,957	12,353	15,592	18,798	27,648	47,896	69,351
225	5,731	8,128	12,618	15,926	19,201	28,240	48,923	70,837
230	5,851	8,298	12,883	16,260	19,604	28,833	49,949	72,323
235	5,971	8,469	13,147	16,594	20,007	29,425	50,975	73,809
240	6,091	8,639	13,412	16,929	20,409	30,017	52,001	75,295
245	6,212	8,810	13,677	17,263	20,812	30,610	53,027	76,781
250	6,332	8,980	13,941	17,597	21,215	31,202	54,054	78,267
Approx. 1 psi Increment	24	34	53	67	81	118	205	297

*Settings below 15 psi (1.1 barg) are non-ASME code.

METRIC UNITS Nm³/HR.

ORIFICE LETTER AREA CM. ²	J 8.762	K 12.426	L 19.287	M 24.347	N 29.357	P 43.174	Q 74.795	R 108.294
SET PRESSURE BARG								
0.4*	722	1,024	1,589	2,006	2,418	3,557	6,161	8,921
0.8*	1,005	1,425	2,212	2,793	3,367	4,952	8,579	12,422
1.1	1,182	1,677	2,603	3,286	3,961	5,826	10,093	14,615
1.5	1,381	1,996	3,052	3,852	4,644	6,831	11,833	17,134
2	1,646	2,327	3,613	4,560	5,498	8,086	14,008	20,283
2.5	1,918	2,720	4,222	5,329	6,425	9,449	16,370	23,703
3	2,198	3,117	4,839	6,108	7,364	10,830	18,762	27,166
3.5	2,478	3,514	5,456	6,887	8,303	12,211	21,154	30,630
4	2,758	3,912	6,073	7,665	9,241	13,592	23,546	34,094
4.5	3,038	4,309	6,690	8,444	10,180	14,973	25,938	37,557
5	3,319	4,707	7,307	9,223	11,119	16,354	28,331	41,021
5.5	3,599	5,104	7,924	10,002	12,058	17,735	30,723	44,485
6	3,879	5,502	8,541	10,780	12,997	19,115	33,115	47,948
6.5	4,159	5,899	9,158	11,559	13,936	20,496	35,507	51,412
7	4,439	6,296	9,775	12,338	14,875	21,877	37,899	54,876
7.5	4,720	6,694	10,392	13,116	15,813	23,258	40,291	58,339
8	5,000	7,091	11,009	13,895	16,752	24,639	42,683	61,803
8.5	5,280	7,489	11,626	14,674	17,691	26,020	45,076	65,267
9	5,560	7,886	12,243	15,453	18,630	27,400	47,468	68,730
9.5	5,841	8,283	12,860	16,231	19,569	28,781	49,860	72,194
10	6,121	8,681	13,477	17,010	20,508	30,162	52,252	75,658
10.5	6,401	9,078	14,093	17,789	21,447	31,543	54,644	79,121
11	6,681	9,476	14,710	18,568	22,385	32,924	57,036	82,585
11.5	6,961	9,873	15,327	19,346	23,324	34,305	59,428	86,049
12	7,242	10,271	15,944	20,125	24,263	35,686	61,820	89,512
12.5	7,522	10,668	16,561	20,904	25,202	37,066	64,213	92,976
13	7,802	11,065	17,178	21,683	26,141	38,447	66,605	96,440
13.5	8,082	11,463	17,795	22,461	27,080	39,828	68,997	99,903
14	8,362	11,860	18,412	23,240	28,019	41,209	71,389	103,367
15	8,923	12,655	19,646	24,798	29,896	43,971	76,173	110,294
16	9,483	13,450	20,880	26,355	31,774	46,732	80,958	117,222
17	10,444	14,245	22,114	27,912	33,652	49,494	85,742	124,149
Approx. 0.1 barg Increment	56.0	79.5	123.4	155.8	187.8	276.2	478.4	692.7

SAFETY RELIEF VALVES

DRIP PAN ELBOWS (DPE)

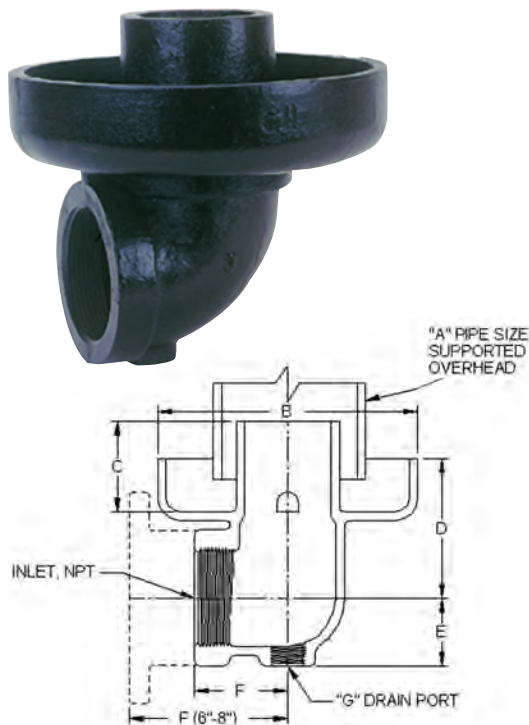

The use of an Apollo International™ drip pan elbow is highly recommended for steam safety valve installations. The drip pan elbow connects to the valve outlet to safely direct steam discharge away from the valve and into the discharge piping. Condensate is directed to drain. Drip pans offer ideal flow characteristics, and serve to isolate the valve from piping stresses that can adversely effect safety valve performance and longevity.

- Sizes 3/4" thru 8", Flanged and Threaded Models
- Material: Gray iron ASTM A126 Class B
- Finish: Black Phosphate or Black Paint Coating

FEATURES

- Ideal Flow Characteristics
- Directs Condensate to Drain
- Isolates Safety Valve from Piping Stresses Caused by:
 - Weight of Discharge Piping
 - Thermal Expansion
 - Reaction Forces During Valve Discharge

INSTALLATION

- Sizes 3/4" thru 4" feature FNPT Connections and Connect Directly to the Valve Outlet by Means of a Short Pipe Nipple or with an Appropriate Companion Flange and Nipple for Flanged Outlet Connections
- Sizes 6" and 8" Have Integral Cast ANSI 125# Flanges that Bolt Directly to the Valve Outlet

SELECTION

- Select the Drip Pan to Match the Nominal Outlet Size of the Safety Valve

DIMENSIONS

PART NUMBER	SIZE (IN.) NPS/DN	INLET CONNECTION	DIMENSIONS (IN./MM)							WT./EA. (LB./KG)
			A NPS/DN	B	C	D	E	F	G NPS/DN	
DPE 07	3/4	FNPT	1-1/2	3.75	1.63	2.25	1	1.5	1/4	2
	20	FNPT	40	95	41	57	25	40	8	.9
DPE 10	1	FNPT	1-1/2	3.75	1.63	2.25	1	1.5	1/4	2
	25	FNPT	40	95	41	57	25	40	8	.9
DPE 12	1-1/4	FNPT	2	5.5	2.13	3.38	1.5	2.13	3/8	5
	32	FNPT	50	127	54	86	40	54	10	2.1
DPE 15	1-1/2	FNPT	2	5.5	2.13	3.38	1.5	2.13	3/8	5
	40	FNPT	50	127	54	86	40	54	10	2.1
DPE 20	2	FNPT	3	6.25	2.25	3.63	1.63	2.25	1/2	7
	50	FNPT	80	159	57	92	41	57	15	3.2
DPE 25	2-1/2	FNPT	4	7.38	3	4.38	1.88	2.75	3/4	11
	65	FNPT	100	187	80	111	48	70	20	5.0
DPE 30	3	FNPT	4	8	3.5	4.88	2.13	3.13	3/4	17
	80	FNPT	100	200	89	124	54	80	20	7.7
DPE 40	4	125# FLANGE	6	9.63	4.5	5.75	2.63	3.75	3/4	30
	100	125# FLANGE	150	245	114	146	67	95	20	13.6
DPE 60	6	125# FLANGE	8	12.75	6.63	7.63	3	8	3/4	84
	150	125# FLANGE	200	324	168	194	80	200	20	38.1
DPE 80	8	125# FLANGE	10	16.5	7.5	8.63	4.13	10.75	1	151
	200	125# FLANGE	250	419	191	219	105	273	25	68.5

500 SERIES
MULTI-PURPOSE SAFETY RELIEF



Versatile safety relief valve available in bronze, carbon steel or all stainless steel construction, suitable for a wide range of steam, air, gas and liquid applications. High capacity full nozzle design is available with metal to metal, PCTFE or elastomer O-ring seating. Short tuned blowdown and backpressure tight body minimizes fugitive emissions and product losses in the event of valve operation.

ASME SECTION VIII

- Sizes 1/2" thru 2" NPT
- Factory Set Pressure Range: 5-1200 psig @ 800°F max.
- (See Pressure/temperature Limit Chart Below for Specific Ratings for Each Model)

APPLICATIONS

- Pressure Vessels and Pressure Piping Systems
- Pumps, Tanks and Hydraulic Systems
- Thermal Relief of Liquid Filled Vessels
- Chemical, Process and Other Industrial Plants
- Power Plant Auxiliary Systems
- Cryogenic and Industrial Gases
- Air and Gas Compressors and Dryers
- Vacuum Relief

FEATURES

- Wide Range of Materials and Options
- One Trim Design is Suitable for Steam, Air / Gas and Liquid Service
- High Capacity Full Nozzle Design
- Stainless Steel Springs
- Integral Lift Stop
- Self-Aligning Pivoting Disc
- API 527 Seat Tightness, Standard for all Models
- Tuned Blowdown - Short and Adjustable, Reduces Product Losses
- Backpressure Tight Design Minimizes Fugitive Emissions
- CSA B51 CRN OG8547.5C

OPTIONS

- Screwed Cap Standard), Packed Lift Lever
- Test Gags
- Elastomer or PCTFE Soft Seat for Exceptional Seat Tightness
- High Temperature Alloy Springs for 550°F - 800°F Service
- Special Cleaning Available
- European Pressure Equipment Directive Compliant Option (CE/PED)

PART NUMBER MATRIX

52	3	J	H	B	K	M	AA	0425	Q
SERIES BODY/TRIM MATERIAL	CAP	ORIFICE LETTER	INLET SIZE	CONNECTION	SERVICE	SEAT	SPECIAL OPTIONS	SET PRESSURE	SUFFIX
51 - BRONZE/BRASS	1 - SCREWED CAP	D	C - 1/2	B - MNPT X NPT	J - SEC VIII LIQUID	M - METAL	FACTORY ISSUED LETTERS/NUMBERS FOR SPECIAL OPTIONS OR FEATURES	SET PRESSURE, PSIG (4 DIGITS)	Q - PERFORMANCE (CALIBRATION) TEST REPORTS
52 - BRONZE/SS	2 - SCREWED + GAG	E	D - 3/4	D - 3/4 OUTLET (MODEL 510 & 520 D ORIFICE ONLY)	K - SEC VIII AIR/GAS	B - BUNA-N		VACUUM "HG" PREFIX + 2 DIGITS	
53 - CARBON/SS	3 - PACKED LEVER	F	E - 1		L - SEC VIII STEAM	E - EPR			
54 - ALL STAINLESS	4 - PACKED + GAG	G	F - 1-1/4		M - NON CODE LIQUID	K - PCTFE			
		H	G - 1-1/2		N - NON CODE AIR	N - NEOPRENE	"AA" - DEFAULT SETTING		
		J	H - 2	P - NON CODE STEAM	Z - KALREZ®	"CE" - CE/PED			
				Q - VACUUM	S - SILICONE	"HT" - HIGH TEMP SPRING			
					V - VITON	"OX" - CLEANED FOR OXYGEN			

Notes:
 1. The ASME Code Section VIII requires a lift lever for the following services: air, steam, or hot water over 140°F
 2. Maximum back pressure is 50 psig.
 3. High temperature stainless steel alloy spring is required above 550°F / 288°C. Specify option "HT" (Minimum pressure setting with HT option = 276 psig)
 4. Contact factory for pricing and availability.

**500 SERIES
MULTI-PURPOSE SAFETY RELIEF**

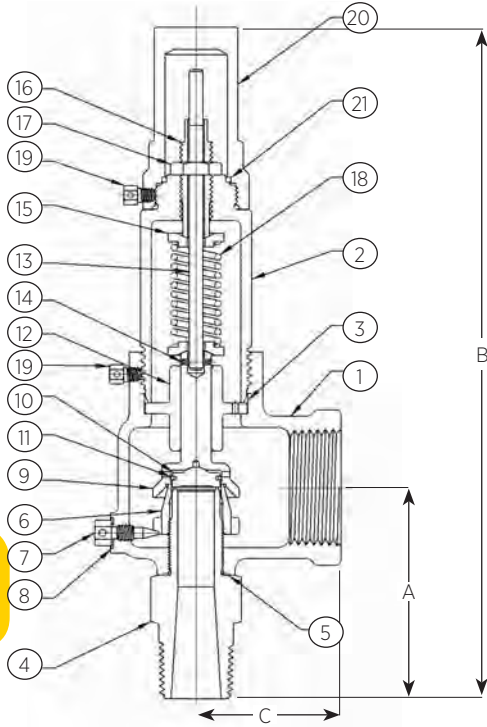

SCREWED CAP

STANDARD MATERIAL LIST

		510 SERIES	520 SERIES	530 SERIES	540 SERIES
1	Body	Bronze, B-584-C844	Bronze, B-584-C844	Steel, SA-216 WCB	SS, SA-351-CF8M
2	Bonnet	Brass*	Brass*	Steel**	SS Type 316***
3	Bonnet Seal	PTFE	PTFE	PTFE	PTFE
4	Nozzle	Brass B-16	SS Type 316	SS Type 316	SS Type 316
5	Nozzle Seal	PTFE	PTFE	PTFE	PTFE
6	Nozzle Ring	SS Type 316	SS Type 316	SS Type 316	SS Type 316
7	Set Screw	Brass	Brass	SS Type 316	SS Type 316
8	Set Screw Seal	PTFE	PTFE	PTFE	PTFE
9	Disc Holder	Brass	SS Type 316	SS Type 316	SS Type 316
10	Disc	SS Type 316	SS type 316	SS Type 316	SS Type 316
11	Retaining Ring	Stainless Steel	Stainless Steel	Stainless Steel	Stainless Steel
12	Disc Guide	Brass	Brass	SS Type 316	SS Type 316
13	Stem	Stainless Steel	Stainless Steel	SS Type 316	SS Type 316
14	Spring Pin	Stainless Steel	Stainless Steel	Stainless Steel	Stainless Steel
15	Spring Washer	Brass	Brass	SS Type 316	SS Type 316
16	Adjusting Bolt	Brass	Brass	SS Type 316	SS Type 316
17	Lock Nut	Brass	Brass	SS Type 316	SS Type 316
18	Spring	Stainless Steel	Stainless Steel	Stainless Steel	Stainless Steel
	Spring, High Temp.	Inconel	Inconel	Inconel	Inconel
19	Lock Screw	Stainless Steel	Stainless Steel	Stainless Steel	Stainless Steel
20	Cap, Screwed	Brass	Brass	Steel	SS Type 316
21	Seal, Cap	Viton	Viton	Viton	Viton
-	Nameplate	Stainless Steel	Stainless Steel	Stainless Steel	Stainless Steel
-	Drive Screw	Stainless Steel	Stainless Steel	Stainless Steel	Stainless Steel
-	Seal & Wire	Lead/SS	Lead/SS	Lead/SS	Lead/SS
-	Seal & Wire (Ce)			Aluminum/SS	Aluminum/SS

Notes:
 * Sizes G, H and J are Cast Bronze
 ** Sizes H and J are Cast Steel
 *** Sizes H and J are Cast Stainless Steel Type 316

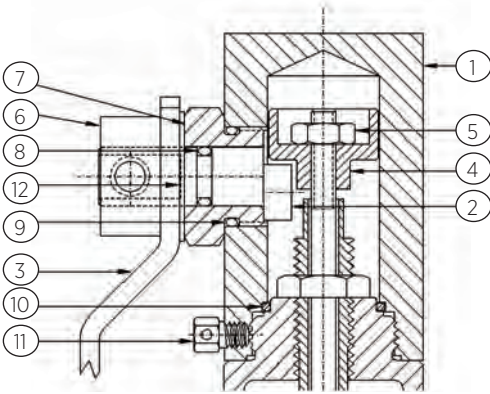

PACKED LEVER

LIFT LEVER OPTION

		513/523 SERIES	533 SERIES	543 SERIES
1	Cap, Packed Lever	Brass	Steel	SS Type 316
2	Cam Bushing	Stainless Steel	Stainless Steel	Stainless Steel
3	Lever	Stainless Steel	Stainless Steel	Stainless Steel
4	Lift Washer	Stainless Steel	Stainless Steel	Stainless Steel
5	Locknut	Stainless Steel	Stainless Steel	Stainless Steel
6	Collar	Stainless Steel	Stainless Steel	Stainless Steel
7	Cam Bushing	Brass	Stainless Steel	Stainless Steel
8	Cam O-Ring	Viton	Viton	Viton
9	Bushing O-Ring	Viton	Viton	Viton
10	Seal, Cap	Viton	Viton	Viton
11	Set Screw	Stainless Steel	Stainless Steel	Stainless Steel
12	Washer	PTFE	PTFE	PTFE

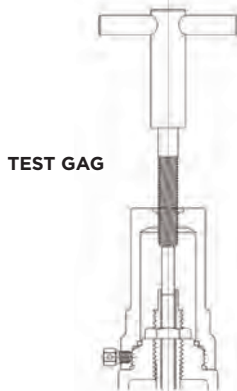

TEST GAG

SEATS

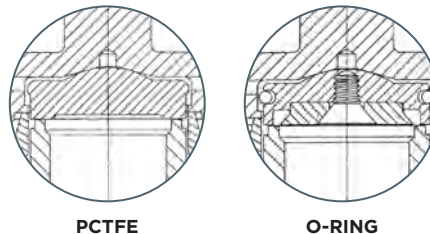

PTFE

O-RING

**500 SERIES
MULTI-PURPOSE SAFETY RELIEF**

SOFT SEAT PRESSURE & TEMPERATURE LIMITS* - 500 SERIES

SEAT MATERIAL	SET PRESSURE		TEMPERATURE		SERVICE RECOMMENDATIONS**
	MIN.	MAX.	MIN.	MAX.	
Viton	15	900	-15°F	400°F	Air, Benzene, Butane, Carbon Dioxide, Carbon Disulphide, Carbon Tetrachloride, Dowtherm A, Ethyl Alcohol, Ethyl Chloride, Ethylene, Ethylene Glycol, Fuel Oil, Gasoline, Hydraulic Fluid, JP-4 and -5 Fuel, Kerosene, Lube Oil, Natural Gas, Naphtha, Nitrogen, Propane, Propyl Alcohol, Propylene, Propylene Glycol, Sulphur Dioxide, Toluene, Trichlorethylene, Turpentine, Vinyl Chloride, Water
EPDM	15	900	-70°F	250°F	Steam, Water, Hot Water, Acetone, Beer, Brake Fluid, Hydrogen Gas, Hydrogen Sulphide, Phosphate Ester Hydraulic Fluid, Sulphur Dioxide, Acids, Alkalis
Silicone	15	900	-60°F	450°F	Air, Helium, Nitrogen, Oxygen (gaseous)
Neoprene	15	900	-35°F	225°F	Air, Anhydrous Ammonia, Butane, Butyl Alcohol, Castor Oil, Denatured Alcohol, Ethanol, Ethyl Alcohol, Freon 12, 13, 14 & 22, Glycols, Natural Gas, Oxygen (gaseous), Silicate Esters
Nitrile / Buna-N	15	900	-30°F	250°F	Air, Anhydrous Ammonia, Butane, Carbon Dioxide, Diesel Oil, Freon 11 & 12, Fuel Oil, Gasoline, Helium, Hydraulic Fluid (petroleum based), Hydrogen Sulphide, Hydrogen Gas, Kerosene, Lube Oil, Natural Gas, Nitrogen, Oxygen (gaseous), Propane, Propylene, Sulphur Dioxide, Vinyl Chloride
PCTFE	15	500	-320°F	250°F	Cryogenic Service including Argon, Carbon Dioxide, Helium, Hydrogen, Nitrogen, Oxygen

Notes:
 * Subject to valve body material pressure / temperature limitations. See chart below.
 ** Service recommendations are provided for guidance only. Material suitability and selection should be determined by the end user based on their prior experience with the service and materials involved.

PRESSURE AND TEMPERATURE RATINGS

SERIES BODY TRIM	510 BRONZE BRASS	520 BRONZE STAINLESS	530 CARBON STEEL STAINLESS	540 STAINLESS STEEL STAINLESS
Max. Set-Steam	250 PSI	300 PSI	900 PSI (D/E) 600 PSI (F/G) 500 PSI (H/J)	900 PSI (D/E) 600 PSI (F/G) 500 PSI (H/J)
Max. Set-Air/ Gas/Liquid	300 PSI	1200 PSI (D) ¹ 900 PSI (E) 600 PSI (F/G) 500 PSI (H/J)	1200 PSI (D) ¹ 900 PSI (E) 600 PSI (F/G) 500 PSI (H/J)	1200 PSI (D) ¹ 900 PSI (E) 600 PSI (F/G) 500 PSI (H/J)
Temp. Limits*	-320/406°F	-320/422°F	-20/800°F	-320/800°F

¹Max set pressure for liquids is 1000 psi.
 Notes:
 Limits based upon materials of construction and use of metal to metal seating. Refer to 500 series soft seat chart for limitations based upon elastomer.
 Specify "HT" high temperature Inconel springs for service temperature beyond 422°F. (Minimum pressure setting with HT option = 138 psig)
 Models 510, 520 and 540 are suitable for cryogenic service to -320°F, with choice of either "M" metal or "K" PCTFE seat options.

AVAILABLE CONFIGURATIONS

MODEL NUMBER	ORIFICE LETTER	SIZE INLET X OUT-LET	DIMENSIONS (IN./MM)			WEIGHT (LB./KG)
			A	B	C	
5xxDC	D	1/2 X 1	2.38	7.5	1.63	2
			60	191	41	0.9
5xxDCD*	D	1/2 X 3/4	2.38	7.5	1.63	2
			60	191	41	0.9
5xxDD	D	3/4 X 1	2.38	7.5	1.63	2
			60	191	41	0.9
5xxDDD*	D	3/4 X 3/4	2.38	7.5	1.63	2
			60	191	41	0.9
5xxED	E	3/4 X 1-1/4	2.63	9	2	3
			67	229	51	1.4
5xxEE	E	1 X 1-1/4	2.63	9	2	3
			67	229	51	1.4
5xxFE	F	1 X 1-1/2	2.83	10.25	2.38	5
			73	260	60	2.3
5xxFF	F	1-1/4 X 1-1/2	2.83	10.25	2.38	5
			73	260	60	2.3
5xxGF	G	1-1/4 X 2	3.25	13.25	2.63	9
			83	337	67	4.1
5xxGG	G	1-1/2 X 2	3.25	13.25	2.68	9.5
			83	337	67	4.31
5xxHG	H	1-1/2 X 2-1/2	3.5	15	2.75	15.5
			89	381	70	7.0
5xxHH	H	2 X 2-1/2	3.5	15	2.75	16
			89	381	70	7.3
5xxJH	J	2 X 3	4	17	3.25	24
			102	432	83	10.9

* 3/4" Outlet option available with 510 and 520 bronze bodied models only.

SAFETY RELIEF VALVES

**500 SERIES
MULTI-PURPOSE SAFETY RELIEF**

ASME SECTION VIII - STEAM

• Pounds per hour (kilograms per hour) saturated steam at 10% overpressure. National Board Certified. Ratings are 90% of actual.

US CUSTOMARY UNITS LB/HR.

ORIFICE LETTER AREA (IN. ²)	D 0.1295	E 0.2282	F 0.3589	G 0.5890	H 0.9195	J 1.5044
SET PRESSURE PSIG						
5*	122	216	339	557	869	1,422
10*	168	295	465	762	1,190	1,947
15	188	331	520	853	1,332	2,180
20	216	381	600	984	1,536	2,513
25	245	432	679	1,114	1,740	2,846
30	274	482	759	1,245	1,943	3,180
35	305	538	846	1,388	2,168	3,546
40	337	593	934	1,532	2,392	3,913
45	368	649	1,021	1,676	2,616	4,280
50	400	705	1,108	1,819	2,840	4,646
55	431	760	1,196	1,963	3,064	5,013
60	463	816	1,283	2,106	3,288	5,380
65	494	872	1,371	2,250	3,512	5,746
70	526	927	1,458	2,393	3,736	6,113
75	558	983	1,546	2,537	3,960	6,479
80	589	1,038	1,633	2,680	4,184	6,846
85	621	1,094	1,721	2,824	4,408	7,213
90	652	1,150	1,808	2,968	4,632	7,579
95	684	1,205	1,896	3,111	4,857	7,946
100	715	1,261	1,983	3,255	5,081	8,313
125	873	1,539	2,421	3,972	6,201	10,146
150	1,031	1,817	2,858	4,690	7,322	11,979
175	1,189	2,095	3,295	5,408	8,442	13,812
200	1,346	2,373	3,733	6,126	9,562	15,645
225	1,504	2,651	4,170	6,843	10,683	17,478
250	1,662	2,929	4,607	7,561	11,803	19,312
275	1,820	3,207	5,045	8,279	12,924	21,145
300	1,977	3,485	5,482	8,997	14,044	22,978
325	2,135	3,763	5,919	9,714	15,165	24,811
350	2,293	4,041	6,357	10,432	16,285	26,644
375	2,451	4,319	6,794	11,150	17,405	28,477
400	2,608	4,597	7,231	11,867	18,526	30,311
425	2,766	4,875	7,669	12,585	19,646	32,144
450	2,924	5,153	8,106	13,303	20,767	33,977
475	3,082	5,431	8,543	14,021	21,887	35,810
500	3,239	5,709	8,981	14,738	23,008	37,643
525	3,397	5,987	9,418	15,456	-	-
550	3,555	6,266	9,855	16,174	-	-
575	3,713	6,544	10,293	16,892	-	-
600	3,870	6,822	10,730	17,609	-	-
625	4,028	7,100	-	-	-	-
650	4,186	7,378	-	-	-	-
675	4,344	7,656	-	-	-	-
700	4,501	7,934	-	-	-	-
725	4,659	8,212	-	-	-	-
750	4,817	8,490	-	-	-	-
775	4,975	8,768	-	-	-	-
800	5,132	9,046	-	-	-	-
825	5,290	9,324	-	-	-	-
850	5,448	9,602	-	-	-	-
875	5,606	9,880	-	-	-	-
900	5,763	10,158	-	-	-	-
Approx. 1 psi Increment	6.3	11.1	17.5	28.7	44.8	73.3

METRIC UNITS KG/HR.

ORIFICE LETTER AREA (CM. ²)	D 0.8352	E 1.4721	F 2.3155	G 3.8001	H 5.9321	J 9.7058
SET PRESSURE BARG						
0.4*	60	105	165	271	423	692
0.8*	82	145	228	374	583	955
1.1	88	154	243	398	622	1,018
2	122	214	337	553	863	1,412
3	163	287	451	741	1,156	1,892
4	204	360	566	930	1,451	2,374
5	246	433	681	1,118	1,746	2,857
6	287	506	797	1,307	2,041	3,339
7	329	580	912	1,496	2,336	3,821
8	370	653	1,027	1,685	2,630	4,304
9	412	726	1,142	1,874	2,925	4,786
10	453	799	1,257	2,063	3,220	5,269
12	536	945	1,487	2,441	3,810	6,233
14	619	1,092	1,717	2,818	4,400	7,198
16	702	1,238	1,947	3,196	4,989	8,163
18	786	1,384	2,178	3,574	5,579	9,128
20	869	1,531	2,408	3,952	6,169	10,093
22	952	1,677	2,638	4,329	6,758	11,058
24	1,035	1,823	2,868	4,707	7,348	12,022
26	1,118	1,970	3,098	5,085	7,938	12,987
28	1,201	2,116	3,329	5,463	8,527	13,952
30	1,284	2,262	3,559	5,840	9,117	14,917
32	1,367	2,409	3,789	6,218	9,707	15,882
34	1,450	2,555	4,019	6,596	10,297	16,846
36	1,533	2,701	4,249	6,974	-	-
38	1,616	2,848	4,479	7,351	-	-
40	1,699	2,994	4,710	7,729	-	-
42	1,782	3,140	-	-	-	-
44	1,865	3,287	-	-	-	-
46	1,948	3,433	-	-	-	-
48	2,031	3,579	-	-	-	-
50	2,114	3,726	-	-	-	-
52	2,197	3,872	-	-	-	-
54	2,280	4,019	-	-	-	-
58	2,446	4,311	-	-	-	-
62	2,612	4,604	-	-	-	-
65	2,736	-	-	-	-	-
69	2,902	-	-	-	-	-
72	3,026	-	-	-	-	-
76	3,192	-	-	-	-	-
79	3,316	-	-	-	-	-
82	3,441	-	-	-	-	-
Approx. 0.1 bar Increment	4.15	7.32	11.51	18.89	29.48	48.24

Maximum Set Pressure Limits for Steam Service

510 Series - 250 psig/17.3 barg

520 Series - 300 psig/20.7 barg

530 Series - 900 psig/62.1 barg

540 Series - 900 psig/62.1 barg

Note: For steam service beyond 300 psig or 550 °F specify option "HT" high temperature stainless steel alloy spring.

*Pressure settings below 15 psig/1.03 barg are non-ASME code.

500 SERIES

MULTI-PURPOSE SAFETY RELIEF

ASME SECTION VIII - AIR

Standard cubic feet per minute (normalized cubic meters per hour) of air at 10% overpressure. National Board Certified. Ratings are 90% of actual.

US CUSTOMARY UNITS SCFM

ORIFICE LETTER AREA (IN. ²)	D 0.1295	E 0.2282	F 0.3589	G 0.5890	H 0.9195	J 1.5044
SET PRESSURE PSIG						
5*	39	69	108	178	277	454
10*	54	96	151	248	387	633
15	67	118	185	304	474	776
20	77	136	213	350	547	895
25	87	154	242	397	619	1,013
30	97	172	270	443	692	1,132
35	109	191	301	494	772	1,262
40	120	211	332	545	851	1,393
45	131	231	363	596	931	1,523
50	142	251	395	648	1,011	1,654
55	154	271	426	699	1,091	1,784
60	165	290	457	750	1,170	1,915
65	176	310	488	801	1,250	2,045
70	187	330	519	852	1,330	2,176
75	198	350	550	903	1,410	2,306
80	210	370	581	954	1,489	2,437
85	221	389	612	1,005	1,569	2,567
90	232	409	644	1,056	1,649	2,698
95	243	429	675	1,107	1,729	2,828
100	255	449	706	1,158	1,808	2,959
125	311	548	862	1,414	2,207	3,611
150	367	647	1,017	1,669	2,606	4,264
175	423	746	1,173	1,925	3,005	4,916
200	479	845	1,329	2,180	3,404	5,569
225	535	944	1,484	2,436	3,802	6,221
250	592	1,043	1,640	2,691	4,201	6,874
275	648	1,142	1,796	2,947	4,600	7,526
300	704	1,240	1,951	3,202	4,999	8,179
325	760	1,339	2,107	3,458	5,398	8,831
350	816	1,438	2,263	3,713	5,796	9,484
375	872	1,537	2,418	3,969	6,195	10,136
400	928	1,636	2,574	4,224	6,594	10,789
425	985	1,735	2,730	4,480	6,993	11,441
450	1,041	1,834	2,885	4,735	7,392	12,094
475	1,097	1,933	3,041	4,991	7,791	12,746
500	1,153	2,032	3,197	5,246	8,189	13,399
525	1,209	2,131	3,352	5,501	-	-
550	1,265	2,230	3,508	5,757	-	-
575	1,321	2,329	3,664	6,012	-	-
600	1,378	2,428	3,819	6,268	-	-
625	1,434	2,527	-	-	-	-
650	1,490	2,626	-	-	-	-
675	1,546	2,725	-	-	-	-
700	1,602	2,824	-	-	-	-
725	1,658	2,923	-	-	-	-
750	1,715	3,022	-	-	-	-
775	1,771	3,121	-	-	-	-
800	1,827	3,220	-	-	-	-
825	1,883	3,319	-	-	-	-
850	1,939	3,418	-	-	-	-
875	1,995	3,517	-	-	-	-
900	2,051	3,616	-	-	-	-
950	2,163	-	-	-	-	-
1000	2,276	-	-	-	-	-
1050	2,388	-	-	-	-	-
1100	2,501	-	-	-	-	-
1150	2,613	-	-	-	-	-
1200	2,725	-	-	-	-	-
Approx. 1 psi Increment	2.2	4.0	6.2	10.2	16.0	26.1

METRIC UNITS KG/HR.

ORIFICE LETTER AREA (CM ²)	D 0.8352	E 1.4721	F 2.3155	G 3.8001	H 5.9321	J 9.7058
SET PRESSURE BARG						
0.4*	67	119	187	307	479	784
0.8*	94	165	260	427	667	1,091
1.1	110	195	306	503	784	1,283
2	153	270	425	697	1,089	1,781
3	205	362	569	934	1,458	2,386
4	258	454	714	1,172	1,830	2,994
5	310	546	859	1,411	2,202	3,603
6	362	639	1,005	1,649	2,574	4,211
7	415	731	1,150	1,887	2,946	4,819
8	467	823	1,295	2,125	3,317	5,428
9	519	916	1,440	2,363	3,689	6,036
10	572	1,008	1,585	2,601	4,061	6,644
12	676	1,192	1,875	3,078	4,805	7,861
14	781	1,377	2,166	3,554	5,548	9,078
16	886	1,561	2,456	4,031	6,292	10,295
18	991	1,746	2,746	4,507	7,036	11,511
20	1,095	1,931	3,037	4,983	7,779	12,728
22	1,200	2,115	3,327	5,460	8,523	13,945
24	1,305	2,300	3,617	5,936	9,267	15,162
26	1,409	2,484	3,907	6,413	10,010	16,378
28	1,514	2,669	4,198	6,889	10,754	17,595
30	1,619	2,853	4,488	7,365	11,498	18,812
32	1,724	3,038	4,778	7,842	12,241	20,029
34	1,828	3,222	5,069	8,318	12,985	21,245
36	1,933	3,407	5,359	8,795	-	-
38	2,038	3,591	5,649	9,271	-	-
40	2,142	3,776	5,939	9,747	-	-
42	2,247	3,961	-	-	-	-
44	2,352	4,145	-	-	-	-
46	2,457	4,330	-	-	-	-
48	2,561	4,514	-	-	-	-
50	2,666	4,699	-	-	-	-
52	2,771	4,883	-	-	-	-
54	2,875	5,068	-	-	-	-
58	3,085	5,437	-	-	-	-
62	3,294	5,806	-	-	-	-
65	3,450	-	-	-	-	-
69	3,659	-	-	-	-	-
72	3,815	-	-	-	-	-
76	4,020	-	-	-	-	-
79	4,177	-	-	-	-	-
82	4,381	-	-	-	-	-
Approx. 0.1 bar Increment	5.24	9.23	14.51	23.82	37.18	60.84

Maximum Set Pressure Limits for Air/Gas Service

- 510 Series - 300 psig/20.7 barg
- 520 Series - 1200 psig/82.7 barg
- 530 Series - 1200 psig/82.7 barg
- 540 Series - 1200 psig/82.7 barg

SAFETY RELIEF VALVES

500 SERIES
MULTI-PURPOSE SAFETY RELIEF

ASME SECTION VIII - WATER

• U.S. gallons per minute (cubic meters per hour) of water at 10% over pressure. National Board Certified. Ratings are 90% of actual.

US CUSTOMARY UNITS GPM

ORIFICE LETTER AREA (IN. ²)	D 0.1295	E 0.2282	F 0.3589	G 0.5890	H 0.9195	J 1.5044
SET PRESSURE PSIG						
5*	13	24	37	61	95	156
10*	14	24	38	63	98	161
15	14	25	40	65	102	167
20	16	29	45	74	115	189
25	18	32	50	82	127	208
30	19	34	54	89	138	226
35	21	37	58	96	149	244
40	22	40	62	102	160	261
45	24	42	66	108	169	277
50	25	44	70	114	178	292
55	26	46	73	120	187	306
60	28	48	76	125	195	320
65	29	50	79	130	203	333
70	30	52	82	135	211	345
75	31	54	85	140	218	357
80	32	56	88	145	226	369
85	33	58	91	149	233	381
90	34	59	93	153	239	392
95	35	61	96	158	246	402
100	36	63	98	162	252	413
125	40	70	110	181	282	462
150	44	77	121	198	309	506
175	47	83	130	214	334	546
200	50	89	139	229	357	584
225	53	94	148	242	378	619
250	56	99	156	256	399	653
275	59	104	163	268	418	685
300	62	108	171	280	437	715
325	64	113	178	291	455	744
350	66	117	184	302	472	772
375	69	121	191	313	489	799
400	71	125	197	323	505	826
425	73	129	203	333	520	851
450	75	133	209	343	535	876
475	77	136	215	352	550	900
500	79	140	220	361	564	923
525	81	143	226	370	-	-
550	83	147	231	379	-	-
575	85	150	236	388	-	-
600	87	153	241	396	-	-
625	89	157	-	-	-	-
650	91	160	-	-	-	-
675	92	163	-	-	-	-
700	94	166	-	-	-	-
725	96	169	-	-	-	-
750	97	171	-	-	-	-
775	99	174	-	-	-	-
800	100	177	-	-	-	-
825	102	180	-	-	-	-
850	104	183	-	-	-	-
875	105	185	-	-	-	-
900	107	188	-	-	-	-
950	109	-	-	-	-	-
1000	112	-	-	-	-	-

METRIC UNITS M3/HR.

ORIFICE LETTER AREA (CM ²)	D 0.8352	E 1.4721	F 2.3155	G 3.8001	H 5.9321	J 9.7058
SET PRESSURE BARG						
0.4*	2.0	3.6	5.6	9.2	14.4	23.6
0.8*	2.9	5.1	8.0	13.1	20.4	33.3
1.1	3.3	5.9	9.3	15.2	23.8	38.9
2	4.4	7.7	12.1	19.8	30.9	50.6
3	5.3	9.4	14.8	24.2	37.8	61.8
4	6.1	10.8	17.0	28.0	43.6	71.4
5	6.9	12.1	19.0	31.3	48.8	79.8
6	7.5	13.3	20.9	34.2	53.4	87.4
7	8.1	14.3	22.5	37.0	57.7	94.5
8	8.7	15.3	24.1	39.5	61.7	101.0
9	9.2	16.2	25.6	41.9	65.5	107.1
10	9.7	17.1	26.9	44.2	69.0	112.9
12	10.6	18.8	29.5	48.4	75.6	123.7
14	11.5	20.3	31.9	52.3	81.6	133.6
16	12.3	21.7	34.1	55.9	87.3	142.8
18	13.0	23.0	36.1	59.3	92.6	151.5
20	13.7	24.2	38.1	62.5	97.6	159.7
22	14.4	25.4	39.9	65.6	102.3	167.5
24	15.1	26.5	41.7	68.5	106.9	174.9
26	15.7	27.6	43.4	71.3	111.3	182.0
28	16.3	28.7	45.1	74.0	115.5	188.9
30	16.8	29.7	46.7	76.6	119.5	195.5
32	17.4	30.6	48.2	79.1	123.4	202.0
34	17.9	31.6	49.7	81.5	127.2	208.2
36	18.4	32.5	51.1	83.9	-	-
38	18.9	33.4	52.5	86.2	-	-
40	19.4	34.2	53.9	88.4	-	-
42	19.9	35.1	-	-	-	-
44	20.4	35.9	-	-	-	-
46	20.8	36.7	-	-	-	-
48	21.3	37.5	-	-	-	-
50	21.7	38.3	-	-	-	-
52	22.2	39.0	-	-	-	-
54	22.6	39.8	-	-	-	-
58	23.4	41.2	-	-	-	-
62	24.2	42.6	-	-	-	-
65	24.8	-	-	-	-	-
69	25.6	-	-	-	-	-

Maximum Set Pressure Limits for Liquid Service

510 Series - 300 psig/20.7 barg

520 Series - 1000 psig/68.9 barg

530 Series - 1000 psig/68.9 barg

540 Series - 1000 psig/68.9 barg

Note:

To determine water capacity at 25% overpressure, multiply the capacity at 10% by 1.066.

*Pressure settings below 15 psig/1.03 barg are non-ASME code.



EQUIVALENTS AND CONVERSION FACTORS

TO OBTAIN	MULTIPLY THIS	BY THIS
Atmospheres	Kilograms per sq. cm.	0.9678
Atmospheres	Pounds per sq. inch	0.068
Bar	Pounds per sq. inch	0.06895
Barrels	Cubic feet	0.1781
Bar	KiloPascals	0.01
Bar	Atmospheres	1.013
BTU/hr	Horsepower of boiler	33,479
BTU/hr	Kilowatts/hour	3,412
BTU/hr	MBH	1,000
BTU/hr	Pounds of steam/hour	1,000
BTU/hr	Watts/hour	3,412
Centimeters	Feet	30.48
Centimeters	Inches	2.54
Centimeters	Meters	100
Centipoise	SSU	0.2205 x SG
Centistoke	SSU	0.2162
Cubic centimeters	Cubic inches	16.39
Cubic centimeters	Gallons (U.S.)	3785
Cubic centimeters	Liters	1000
Cubic feet	Gallons (U.S.)	0.1337
Cubic feet	Liters	0.03531
Cubic feet per minute	Cubic meters per minute	35.31
Cubic feet per second	Gallons per minute	0.002228
Cubic inches	Gallons (U.S.)	231
Cubic inches	Gallons (Imperial)	277.4
Cubic meters per minute	Cubic feet per minute	0.02832
Cubic yards	Cubic centimeters	0.06102
Feet	Centimeters	0.03281
Feet	Inches	0.08333
Feet	Meters	3.281
Feet of water	Atmospheres	33.96
Feet of water (68°F)	Inches of mercury (0°C)	1.135
Feet of water (68°F)	Pounds per sq. inch	2.31
Gallons	Cubic feet	7.481
Gallons	Cubic inches	0.004329
Gallons	Cubic meters	264.2
Gallons	Liters	0.2642
Gallons (Imperial)	Gallons (U.S.)	0.8327
Gallons (U.S.)	Barrels	42
Gallons H2O @ 60°F (US)	Pounds	0.1199
Gallons per minute	Cubic feet per second	448.8
Gallons per minute	Cubic meters per hour	4.403
Gallons per minute	Liters per hour	0.004403
Gallons per minute liquid	Pounds per hour liquid	0.002/Sp.Gr.
Grams	Pounds	453.6
Inches	Centimeters	0.3937
Inches	Meters	39.97
Inches of mercury	Atmospheres	29.92
Inches of mercury	Kilograms per sq. cm	28.96
Inches of mercury (0° C)	Inches of water (68°F)	0.07343
Inches of mercury (0° C)	Feet of water (68°F)	0.8812
Inches of mercury (0° C)	Pounds per sq. inch	2.036
Inches of water	Atmospheres	407.5
Inches of water (68°F)	Pounds per sq. inch	27.73
Kilograms	Pounds	0.4536
Kilograms per hour	Pounds per hour	0.4536
Kilograms per hour	Gallons per minute (60°F)	227.0xSG
Kilograms per sq. cm	KiloPascals	0.0102
Kilograms per sq. cm	Inches of mercury (0°C)	0.03453
Kilograms per sq. cm	Bars	1.02
Kilograms per sq. cm.	Atmospheres	1.033
Kilograms per sq. cm.	Pounds per sq. inch	0.07031
KiloPascals	Pounds per sq. inch	6.895
KiloPascals	Atmospheres	101.3
KiloPascals	Bars	100
Liters	Gallons (U.S.)	3.785

TO OBTAIN	MULTIPLY THIS	BY THIS
Liters per minute	Gallons per minute	3.785
Liters per second	Gallons per minute	0.06309
M ³ /hr.	Gallons per minute	0.2271
Meters	Inches	0.0254
Meters	Centimeters	0.01
Meters	Feet	0.3048
Meters of water (68°F)	Pounds per sq. inch	0.7043
Metric tons	Pounds	0.0004536
Millimeters of mercury	Atmospheres	760
Millimeters of mercury (0° C)	Pounds per sq. inch	51.71
Molecular weight (of gas or vapors)	Specific gravity (of gas or vapors)	28.97
Nm ³ /day, (0° C, 1 Bara)	Standard cubic feet per min.	39.11
Nm ³ /hr. (0° C, 1 Bara)	Standard cubic feet per min.	1.63
Nm ³ /min. (0° C, 1 Bara)	Standard cubic feet per min.	0.02716
Ounces	Grams	0.03527
Ounces	Kilograms	35.27
Ounces	Pounds	16
Pounds	Gallons of water (60°F)	8.337
Pounds	Kilograms	2.205
Pounds	Water (cubic feet @ 60F)	62.37
Pounds per cubic foot	Kilograms per cubic meter	0.0624
Pounds per hour	Kilograms per minute	132.3
Pounds per hour liquid	Gallons of liquid per minute	500xSp. Gr.
Pounds per sq. in.	Inches of water (68°F)	0.03607
Pounds per sq. in.	Kilograms per sq. cm.	14.22
Pounds per sq. in.	KiloPascals	0.145
Pounds per square inch	Inches of mercury (0° C)	0.4912
Pounds per square inch	Atmospheres	14.7
Pounds per square inch	Bars	14.5
Pounds per square inch	Feet of water (68°F)	0.4328
PSI	MegaPascals	145.038
SCFM	Pounds per hour	6.324/M.W.
Short tons (2000 lb.)	Kilograms	0.001102
Short tons (2000 lb.)	Pounds	0.0005
Sm ³ /day.	Standard cubic feet per min.	40.78
Sm ³ /hr.	Standard cubic feet per min.	1.699
Sm ³ /min.	Standard cubic feet per min.	0.02832
Square centimeter	Square inch	6.4516
Square inch	Square centimeter	0.155
Square millimeter	Square inch	645.16
Standard cubic ft. per day	Standard cubic feet per min.	1440
Standard cubic ft. per hr	Standard cubic feet per min.	60
Yards	Centimeters	0.01094
Yards	Feet	0.3333
Yards	Inches	0.02778
Yards	Meters	1.094
Temperature:		
Centigrade	= 5/9 (Fahrenheit - 32)	
Kelvin	= Centigrade + 273	
Fahrenheit	= 9/5 (Centigrade) +32	
Fahrenheit	= Rankine - 460	
Fahrenheit	= (9/5 Kelvin) - 460	

CORRECTION FACTORS

AIR AND GAS TEMPERATURE

- To correct for temperatures other than 60°F at the valve inlet, multiply the SCFM from the capacity tables by factor K_t .

TEMP °F	K_t
0	1.063
10	1.052
20	1.041
30	1.030
40	1.020
50	1.010
60	1.000
70	0.991
80	0.981
90	0.972
100	0.964
120	0.947
140	0.931
160	0.916
180	0.901
200	0.888
220	0.874
240	0.862
260	0.850
280	0.838
300	0.827
320	0.816
340	0.806
360	0.796
380	0.787
400	0.778
420	0.769
440	0.760
460	0.752
480	0.744
500	0.737
550	0.718
600	0.701
650	0.685
700	0.669
750	0.656

GAS AND LIQUID RELATIVE DENSITY

- To correct for a specific gravity other than air or water (=1.0) multiply the SCFM or GPM from the capacity tables by factor K_{sg} .

SPECIFIC GRAVITY	K_{sg}
0.10	3.160
0.20	2.240
0.30	1.825
0.40	1.580
0.50	1.414
0.55	1.350
0.60	1.290
0.65	1.240
0.70	1.195
0.75	1.155
0.80	1.117
0.90	1.085
0.95	1.025
1.00	1.00
1.05	0.975
1.10	0.955
1.15	0.933
1.20	0.913
1.25	0.913
1.30	0.877
1.40	0.845
1.50	0.817
1.60	0.791
1.70	0.768
1.80	0.745
1.90	0.725
2.00	0.707
2.50	0.633
3.00	0.577
3.50	0.535
4.00	0.500
4.50	0.471

"Apollo"®

RELIEF VALVES

12-200	F-3
13	F-3
14-200	F-3
17-400	F-3
10	F-4
10-600	F-4
18C-400	F-4
37-200	F-4

WATER PRESSURE REDUCING

36ELF	F5
35	F5
35-603	F5

BALANCING

58A	F6
58B	F-7
58	F-7

THERMAL MIXING

34-200	F-8
34ALF	F-8
34CLF	F-8

BRASS BALL VALVES

77F	F-9
94A	F-11
95ALF	F-11

BRONZE BALL VALVES

70	F-10
70-HC	F-10
77C-A	F-11
PRESS	
77W	F-12
77W-HC	F-12
77V	F-12

EXPANSION

78RV	F-13
78RV-P	F-13
16XT	F-23
40XT	F-23
26-100/300	F-17

GAS SHUT-OFF

GB-10	F-14
GB-15	F-14
GB-50	F-14
GCB-50	F-16
GC-51	F-16
GC2-52	F-16
GCR-55	F-17

CHECK VALVES

70-100-BC	F-15
61-500/600	F-19
62-500	F-19
161S/161SLF	F-21
161T/161TLF	F-21

BOILER DRAIN VALVES

31-200/500	F-15
35-300	F-15

BACKFLOW

4A	F-18
AGD	F-18
DCAP	F-18

GATES/GLOBES

101S/101SLF	F-20
101T/101TLF	F-20
102S/102SLF	F-20
102T/102TLF	F-20

STRAINERS

59	F-22
59-300	F-22
YCT	F-22

MISCELLANEOUS

27-400	F-24
20-100	F-24
27-200	F-24

HYDRONIC & STEAM HEATING



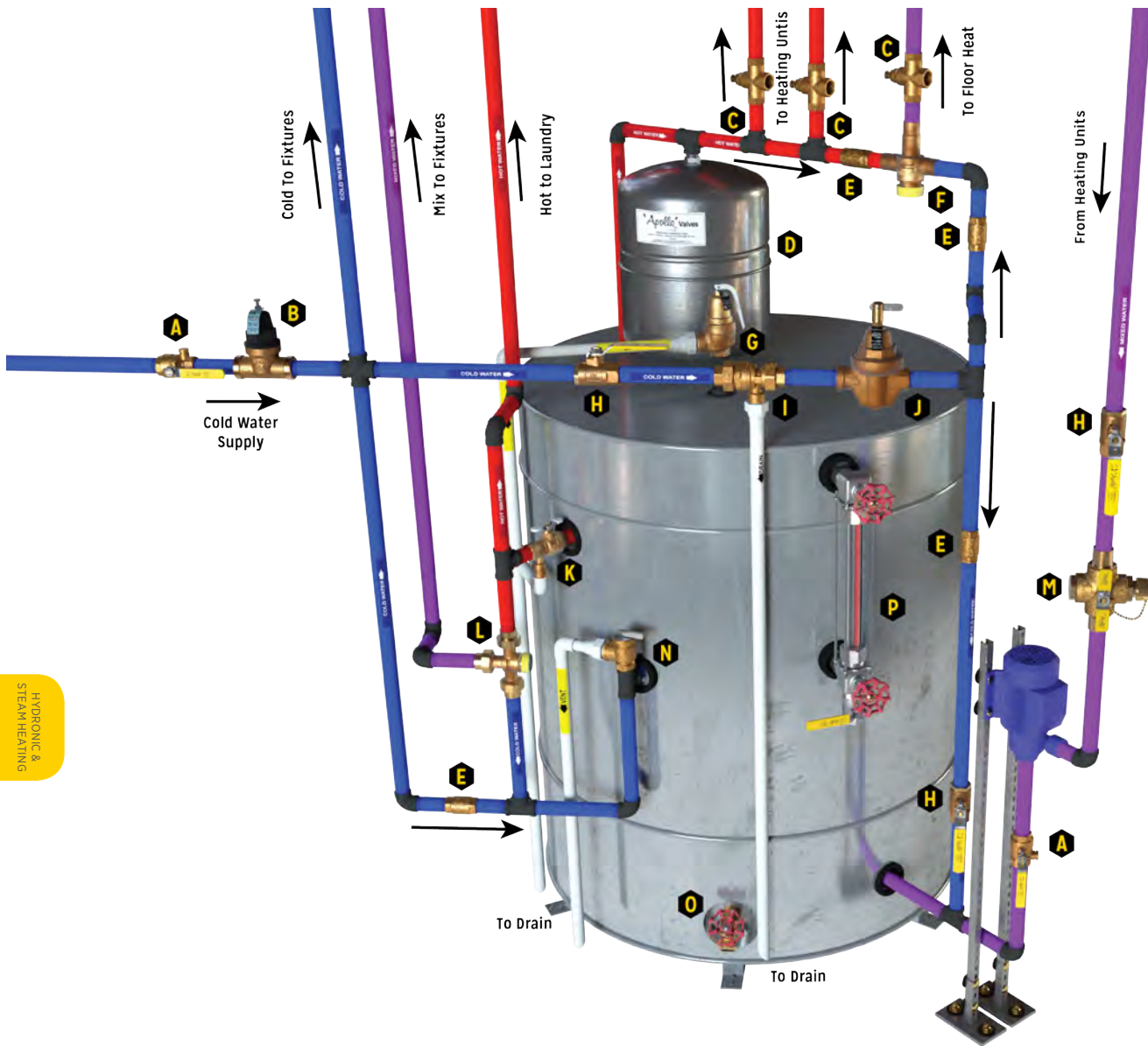

HYDRONIC & STEAM HEATING

- A** BALL VALVE (STOP & WASTE) - 95ALF SERIES
- B** WATER PRESSURE REDUCING VALVE - 36E (PRE) SERIES
- C** HYDRONIC FLOW CHECK - 35-FC (FC) SERIES
- D** HYDRONIC EXPANSION TANK - 16-XT (EXT)
- E** CHECK VALVE - 61 SERIES
- F** TEMPERING VALVE - 34 (TV) SERIES
- G** SAFETY RELIEF VALVE - RVW 60/61 (10-600) SERIES
- H** BALL VALVE - 70 SERIES

- I** DUAL CHECK BACKFLOW - DCAP SERIES
- J** WATER REGULATOR/FILL VALVE - FF (35) SERIES
- K** THERMAL EXPANSION CONTROL VALVE - EXV (78-RV) SERIES
- L** MIXING VALVE - MVA (34ALF) SERIES
- M** BALL VALVE (PURGE & BALANCE) - 78-668
- N** RELIEF VALVE - RVW 17 (17-400) SERIES
- O** BOILER DRAIN - 31 SERIES
- P** LIQUID LEVEL GAUGE - 20-100 SERIES



12-200 (RVS12) SERIES

LOW PRESSURE STEAM HEATING BOILER SAFETY VALVE



Medium capacity safety valves protect ASME Section IV low pressure steam heating boilers. Cast bronze, full nozzle design features PTFE faced elastomer soft seating for dependable operation. Ideal for OEM applications.

FEATURES

- Sizes 2", 2-1/2" and 3"
- Factory Set Pressures 5-15 psi
- All Bronze Construction
- PTFE-Coated O-Ring Seat Seal
- 3/8" NPT Side Tapping for Drain
- Rust-Proofed Steel Spring
- Top Guided, High Capacity Design
- Registered in all Canadian Provinces and Territories, CRN #OG8547.5C
- National Board Certified at 15 psig

SEE PAGE E-10 FOR DETAILED INFORMATION

13 (RVS13) SERIES

LOW PRESSURE STEAM HEATING BOILER SAFETY VALVE



ASME Section IV bronze safety valves protect small to medium low pressure steam heating boilers. Three design configurations feature top guiding and raised seating area for extended service life. Available top and side discharge models.

SEE PAGE E-11 FOR DETAILED INFORMATION

14-200 (RSV14) SERIES

LOW PRESSURE STEAM HEATING SAFETY VALVE



High capacity safety valves protect ASME Section IV low pressure steam heating boilers. Cast bronze, full nozzle design features PTFE faced elastomer soft seating for dependable operation. Ideal for OEM applications.

FEATURES

- Sizes 2", 2-1/2" and 3"
- Factory Set Pressures 5-15 psi
- One Piece Body, All Bronze Construction
- Rust-Proofed Steel Spring
- Chrome Plated Seat, PTFE Coated Disc
- PTFE Coated EPDM O-Ring for Positive Seal
- 3/8" NPT Side Tapping for Drain Connection
- Valves are Capacity Certified by the National Board at 15 psig Only, in Accordance with ASME Boiler and Pressure Vessel Code Section IV
- Registered in all Canadian Provinces and Territories, CRN #OG8547.5C

SEE PAGE E-12 FOR DETAILED INFORMATION

17-400 (RVW17) SERIES

PRESSURE-ONLY HOT WATER RELIEF VALVE



17-400 series pressure-only relief valves are engineered to protect against excessive pressure buildup due to thermal expansion in hot water supply systems. Both models are CSA certified to ANSI Z21.22 "Relief Valves for Hot Water Supply Systems". In addition the 17-402 is design certified to ASME Section IV for hot water relief.

FEATURES

- Connection Sizes 1/2" (Model 17-401) and 3/4" (Model 17-402)
- CSA Verified to ANSI Z21.22
- Pressure Settings 75 thru 150 psi @ 250° F max.
- ASME Section IV Hot Water, Model 17-402 Only
- Cast Bronze Body, Stainless Steel Springs
- Soft Seat for Durability, Extended Service Life
- Conforms to HUD / FHA Requirements
- CSA Certified to ANSI Z21.22
- CSA B-51, CRN OG8547.5C

SEE PAGE E-22 FOR DETAILED INFORMATION

HYDRONIC & STEAM HEATING



10 (RVW30) SERIES
HOT WATER BOILER SAFETY RELIEF



Brass/bronze safety relief valves protect ASME Section IV hot water heating boilers and hydronic heating systems. High capacity design features corrosion resistant construction. Brass, satin or polished chrome finishes available.

FEATURES

- Inlet Size 3/4" - Outlet - 3/4" & 1"
- Factory Set Pressure 20-150 psi
- Maximum Temperature Service: 250°F Pressures From 20 to 150 psig
- Registered in all Canadian Provinces and Territories, CRN #0G8547.5C
- Stainless Steel Springs Standard
- 10-624/634 are Ideal for Use in Various Plumbing Systems, Commercial Boiler Applications and Swimming Pool Heaters
- 10-418/417 are Ideal for Use in Swimming Pool Heater Applications

SEE PAGE E-3 FOR DETAILED INFORMATION

10-600 (RVW60) SERIES
HIGH CAPACITY HOT WATER BOILER SAFETY RELIEF



High-capacity heating system valves with female inlet and standard or expanded female outlet. Elevated seat for drainage of water away from seat area. Entire pressure range is National Board capacity certified.

FEATURES

- Inlet Sizes 3/4" to 2"
- Factory Set Pressures from 15-160 psig
- Maximum Temperature Service 250°F
- High BTU Capacity Rating
- Fabric Reinforced Molded Diaphragm Isolates Spring from Water at all Time
- Bronze Body and Spring Cage
- Silicone Seat
- Registered in Canadian Provinces and Territories, CRN #0G8547.5C
- Protects Against Excessive Water Pressure Due to Failure of Controls to Regulate BTU Input

SEE PAGE E-7 FOR DETAILED INFORMATION

18C-400 (TP) & 18C-402X (TPX) SERIES
WATER HEATER T&P RELIEF



Automatic temperature and pressure relief valves feature unique non-metallic coating which protects the element against galvanic and electromechanical corrosion by isolating it from the heated water. This coating is electrostatically applied for uniform coverage, then thermobonded, resulting in optimum adhesion for extended service life.

FEATURES

- Meets HUD/FHA Requirements
- Cast Bronze Body, Stainless Steel Spring
- Rated @ 210°F Maximum
- Registered in all Canadian Provinces and Territories
- ASME Capacity Certified to 500,000 BTU/hr.

SEE PAGE E-23 FOR DETAILED INFORMATION

37-200 (VR) SERIES
VACUUM RELIEF VALVE



Designed to protect tank from collapsing during water siphoning, resulting in negative pressure. Design certified by CSA in accordance with ANSI Z21.22. Also suitable for low pressure (15 psig max) steam service. Lead free version certified to NSF/ANSI 372.

FEATURES

- Maximum Temperature: 250°F
- Rated for Water Pressures to 200 psig
- Auto-Vacuum Relief at Less than 1" Hg

OPTIONS

- Satin Brass Finish (-01)
- Heavy Spring (-B1)

SERIES NUMBER*	LEAD FREE SERIES NUMBER	SIZE (IN.)	VENTING CAPACITY @ 2" HG	WT./100 (LB.)
37-201-01	37LF-201-01	1/2	15 CFM	30.4
37-202-01	37LF-202-01	3/4	16 CFM	32.4

*Standard materials available until stock is depleted



PRE (36ELF) SERIES
WATER PRESSURE REDUCING VALVE



Designed for residential and commercial applications to protect water supplies from excessive pressure. Excellent flow performance at low pressure drop. The dezincification resistant bronze body and dielectric polymer cage provide maximum corrosion resistance. Designed for easy in-line servicing with simple cartridge removal. They meet ASSE 1003 and CSA B356 standards. They are listed with IAPMO and the city of Los Angeles.

FEATURES

- Balanced Piston Design
- Sealed Cage for Vault Installations
- Built-In Thermal Expansion Bypass
- **PEX A F1960 Cold Expansion Connections NEW!**
- Modular Seat Disc and Strainer Cartridge
- Control Pressure Ranges: 15-75 psi and 75-150 psi
- Integral Stainless Steel Strainer
- NPT, Solder, PEX, CPVC and Press and Push Connections
- Maximum Supply Pressure: 400 psig
- Working Temperature Range: 33°F to 180°F
- **100% Manufactured in USA**

OPTIONS

- **(-B) Bronze Cap NEW!**
- 36E Non-LF Materials for Non-Potable Service, such as Irrigation

APPROVALS

- ASSE 1003
- CSA B356
- NSF/ANSI 372 Lead Free
- NSF/ANSI 61 Water Quality

SEE PAGE H-11 FOR DETAILED INFORMATION

35 (FF) SERIES
BRONZE FEED WATER PRESSURE REGULATOR



Available in 1/2" union threaded, threaded and solder union configurations. Purge lever/fast fill feature. Cartridge replaceable in-line.

FEATURES

- No Cage Screws to Rust
- Individually Set at 15 psig - Adjustable 10 to 25 psig
- Temperatures to 210°F
- Heavy Pattern Bronze Body and Spring Cover
- High Capacity
- In-Line Stainless Steel Strainer Standard
- Choice of Inlet Connections

MODEL NUMBER	PART NUMBER	SIZE (IN.)	HEIGHT (IN.)	LENGTH (IN.)	WT./100 (LB.)
FF12	35-503-01	1/2 Union Threaded	5.25	4.31	255
FFT12	35-603-01	1/2 Threaded	5.25	3.50	225
FFS12	35-703-01	1/2 Solder Union	5.25	3.18	232
FFPR12	35-803-01	1/2 Press Union x NPT	5.25	4.53	232

FFB (35-603-BF) SERIE
COMBINATION BACKFLOW PREVENTER AND FEED REGULATOR

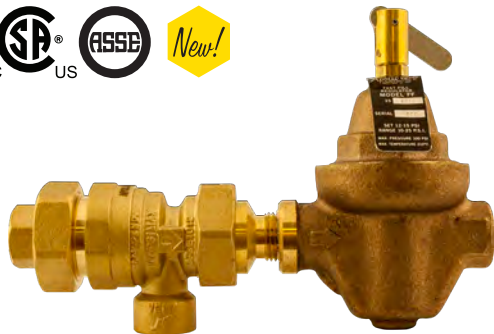

Positive protection against backflow when supply pressure falls below system pressure.

FEATURES

- New Design Dual Check with Atmospheric Port (DCAP) Backflow Device
- Designed for Continuous Pressure, Hot or Cold Water Service
- Fast-Fill Lever on Regulator
- Built in Stainless Steel Strainer
- Maximum Supply Pressure: 100 Psig
- Maximum Temperature: 210°F
- Backflow Device is ASSE and CSA Listed

SERIES NUMBER	SIZE (IN.)	HEIGHT (IN.)	LENGTH (IN.)	NET WT. (LB.)
35603BFST	1/2 Union NPT x NPT	7.90	5.25	3.85
35603BFST	1/2 Solder Union x NPT	7.90	5.25	3.85
35603BFSTC*	1/2 Union NPT x NPT	7.90	5.25	3.85
35603BFSTC*	1/2 Solder Union x NPT	7.90	5.25	3.85

* "C" Models for Canadian market - Discharge port not threaded.

HYDRONIC & STEAM HEATING

**58A SERIES
BALANCING VALVE**

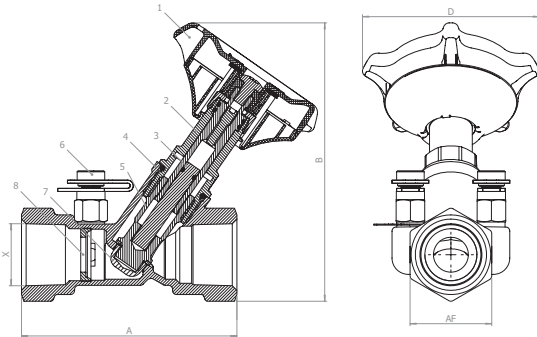

Apollo® Model 58A Balance Valves are precision engineered and manufactured valves which provide two position hydronic circuit isolation capability and multi-turn throttling adjustment as required for proportional balancing of hydronic systems. The unique integrated digital readout in the handle allows qualified technicians to easily adjust the valve to achieve a highly accurate flow. Valve pressure drop can be read through the valves integrated 1/4" measurement ports, and flow calculated from the flow coefficient associated with the numerical setting. The integrated fixed orifice offers greater accuracy than that of a variable orifice.

FEATURES

- P/T Plugs
- Compatible with All Flow Meters
- Easy Adjustment and Setpoint Indicator
- Isolated Flow Shut-off
- Non-Rising Stem
- Y Pattern Body
- Positive Shut Off

APPROVALS

- WRAS
- BS7350
- BS EN 1982
- BS EN 12164

OPTIONS

- NPT Connection
- Solder Connection
- Press Connection
- PEX A Connection
- PEX B/C Connection

PERFORMANCE RATING

- CWP: 300 PSI (200 CWP for Push Fittings)
- Temperature Range: -60°F to 300°F (-10°C to 150°C)

DIMENSIONS

PART NUMBER	SIZE	CONNECTION	DIMENSIONS (IN)				WEIGHT (LB)
			A	B	D	AF	
58A203T	1/2"	FNPT	3.11	4.22	3.54	1.08	1.17
58A204T	3/4"		3.39	4.15		1.26	1.3
58A205T	1"		4.17	4.45		1.57	1.98
58A206T	1-1/4"		4.88	4.72		1.97	2.84
58A207T	1-1/2"		5.12	4.85		2.17	3.7
58A208T	2"	6.26	5.43	2.76	6.53		
58A203S	1/2"	SOLDER	4.35	4.22	3.54	1.08	1.3
58A204S	3/4"		5.03	4.15		1.26	1.54
58A205S	1"		6.85	4.45		1.57	2.32
58A206S	1-1/4"		7.47	4.72		1.97	3.47
58A207S	1-1/2"		8.31	4.85		2.17	4.62
58A208S	2"	10	5.43	2.76	7.88		
58A203X	1/2"	PEX A	5.06	4.22	3.54	1.08	1.3
58A204X	3/4"		5.76	4.15		1.26	1.54
58A205X	1"	7.01	4.45	1.57	2.32		
58A203X2	1/2"	PEX B/C	5.11	4.22	3.54	1.08	1.3
58A204X2	3/4"		5.81	4.15		1.26	1.54
58A205X2	1"	7.06	4.45	1.57	2.32		
58A203P	1/2"	PUSH	5.3	4.22	3.54	1.08	1.39
58A204P	3/4"		5.75	4.15		1.26	1.6
58A205P	1"	6.89	4.45	1.57	2.48		
58A203PR	1/2"	PRESS	4.98	4.22	3.54	1.08	1.35
58A204PR	3/4"		5.56	4.15		1.26	1.62
58A205PR	1"		6.43	4.45		1.57	2.36
58A206PR	1-1/4"		7.42	4.72		1.97	3.42
58A207PR	1-1/2"		8.38	4.85		2.17	4.6
58A208PR	2"	9.88	5.43	2.76	7.75		

STANDARD MATERIALS LIST

Item	Part Name	Material
1	Handle	Glass Filled PA66 (Red)
2	Bonnet	HPb59-3 Brass
3	Seals	EPDM
4	Body	CC752S Brass (BS EN 1982) - DZR
5	Stem	HPb59-3 Brass
6	Test Points	Brass Body & EPDM Plug
7	Nose	CW602N Brass (BS EN 12164) - DZR
8	Orifice Plate	HPb59-3 Brass

HYDRONIC & STEAM HEATING

**58B SERIES
BALANCING VALVE**



Apollo® Model 58B Commercial Double Regulating Valve are intended for the isolation and regulation of sections of pipe work and equipment in HVAC applications and general commercial applications. Valve pressure drop can be read through the valves integrated 1/4" measurement ports, and flow calculated from the flow coefficient associated with the numerical setting on the side of the handle. The valves have non-rising stems that help reduce the amount of space needed. The integrated fixed orifice offers greater accuracy than that of a variable orifice.

FEATURES

- Regulating and Isolating Functions
- Flanged End Connection Compatible with ANSI 125# & 150# Flanges
- Rugged Handwheel
- Grooved End Adapters Available

PERFORMANCE RATING

- Max Working Pressure: 300 PSI
- Temperature Range: 15°F - 250°F (non shock)

DIMENSIONS

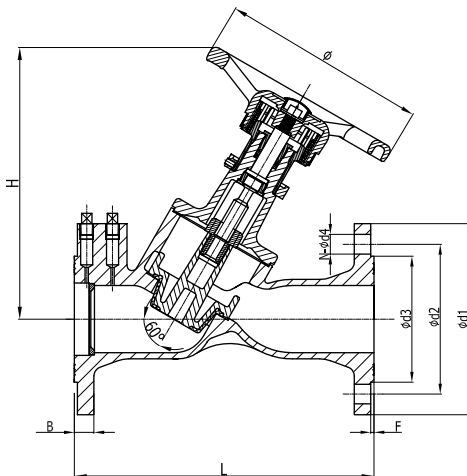

PART NUMBER	SIZE	DIMENSIONS (IN)									WEIGHT (LB)	FLOW RATES	
		L	H	B	Ø	ØD1	ØD2	ØD3	F	N- ØD4		CV	CVS
58B209F	2-1/2"	11.42	10.43	0.69	7.87	7.01	5.5	4.12	0.08	4-Ø 3/4"	38.94	120.23	120.23
58B200F	3"	12.2	10.63	0.75	7.87	7.52	6	5	0.08	4-Ø 3/4"	51.92	129.48	134.11
58B20AF	4"	13.78	12.2	0.94	9.45	9.02	7.5	6.19	0.08	8-Ø 3/4"	66	187.29	246.25
58B20BF	5"	15.75	13.39	0.94	11.42	10	8.5	7.31	0.08	8-Ø 7/8"	99	293.65	384.98
58B20CF	6"	18.9	13.39	1	11.42	10.98	9.5	8.5	0.08	8-Ø 7/8"	114.4	387.29	550.3
58B20EF	8"	23.62	21.14	1.13	13.78	13.5	11.75	10.62	0.08	8-Ø 7/8"	231	618.51	887.88
58B20GF	10"	28.74	22.44	1.19	16.54	15.98	14.25	12.75	0.08	12-Ø 1"	407	1270.55	1332.98
58B20HF	12"	33.46	27.17	1.25	16.54	19.02	17	15	0.08	12-Ø 1"	545.6	1835.89	2015.08

STANDARD MATERIALS LIST

BODY	Ductile Iron	STEM	Stainless Steel
BONNET	Ductile Iron	GASKET	Graphite
DISC	Ductile Iron, EPDM Coated	HANDWHEEL	Carbon Steel (2-1/2" - 4") Ductile Iron (5" - 12")
DISC NAIL	Brass		
"O" RING	EPDM		

**58 (BAV) SERIES
BALANCING VALVE**



Provides dependable hydronic control; for use with 1/2" and 3/4" copper piping. Pressure rated to 150 psig.

FEATURES

- ASTM B584 Bronze
- EPDM O-Ring Seal
- Screw Slot Flow Adjustment
- **Made in USA**

SERIES NUMBER	SIZE (IN.)	CV	WT. (LB.)
58-003-01	1/2 Solder	4	.30
58-004-01	3/4 Solder	14	.5



34-200 SERIES
MIXING VALVE



The Apollo® Model TV (34-200 Series) Thermostatic Mixing Valve provides non-ASSE extension of water heater capacity and hot water temperature control in hydronic heating systems. Available in low or high temperature options for floor or baseboard applications.

FEATURES

- Stainless Steel Spring
- Corrosion Resistant Bronze Body
- Thermoplastic Shuttle Assembly
- Solder Connections are Standard
- In-Line Repairable
- Fingertip Temperature Control
- **Made in USA - ARRA compliant**
**Not intended for potable water*

SEE PAGE G-11 FOR DETAILED INFORMATION

MVA-LF (34ALF) SERIES/MVAH
MIXING VALVE



Apollo® MVA-LF Thermostatic Master Mixing Valves are designed for ASSE 1017 "point of source" applications. They provide reliable hot water temperature control of potable and hydronic hot water distribution systems.

FEATURES

- Superior Thermostatic Element Technology For Optimal Performance, Reliability and Accuracy
- Integral Inlet Strainers and Check Valves are Standard to Protect Against Cross-Flow and Foreign Particles in the Piping System
- Thermostat Over-Temperature Control
- Maximum Temperature Limit Option
- Fingertip Temperature Control
- Cold or Hot Water Supply Failure Shut-Off Protection
- Multiple Connection Options to Fit Your Specific Needs
- High Temperature Version For Hydronic/Radiant Heating Applications
- Standard Materials of Construction Meet the Requirements of the EPA Safe Drinking Water Act
- Lead Free Construction Certified: 0.25% Lead Max
- **Made in USA - ARRA compliant**

SEE PAGE G-4 FOR DETAILED INFORMATION

MVC/MVC-LF (34C/34CLF SERIES) MIXING VALVE



34C Series ASSE 1017 listed, high-capacity mixing valves are thermostatically controlled regulating valves designed for use in large commercial potable and non-potable hot water systems or "point of source" applications. Simple adjustment of water temperature from 90°-140°F or 130°-180°F.

FEATURES

- Sizes: 3/4", 1", 1-1/4", 1-1/2", 2"
- Low Temperature Range: 90°-140°F
- High Temperature Range: 130°-180°F
- Threaded Connections
- Installs Easily on Heating Source
- Patented Design for Easy In-Line Maintenance
- Supply Pressures to 150 psig
- U.S. Patent No. 6,328,219
- CSA B125.01

SEE PAGE G-8 FOR DETAILED INFORMATION



77F/77FLF SERIES

FULL PORT THREADED FORGED BRASS BALL VALVE

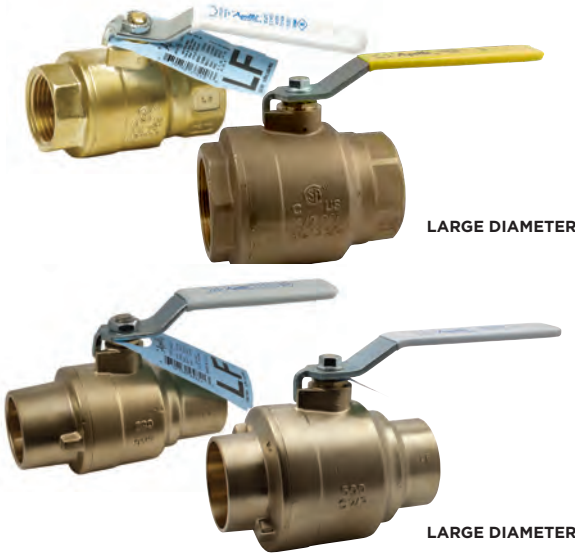

The Apollo® 77F Series is a full port forged brass ball valve suitable for a wide range of plumbing and heating applications. These NPT threaded or solder, 2-piece valves combine reliable operation with maximum economy. Valves include most pertinent agency approvals. **Proudly Made in the USA.**

FEATURES

- Heavy Pattern Forged Design
- Full Port Flow
- Superior RPTFE Seats and Packing
- Adjustable Stem Packing
- Blowout-Proof Stem
- Corrosion Resistant Materials
- 100% Factory Tested
- Popular Lever Options and Stainless Steel Trim Available
- Silicone Free Assembly
- Made in USA, ARRA compliant
- Rating: 600 CWP (1/4" - 2")
- Rating: 400 CWP (2-1/2" - 4")
- Steam Rating: 150 psi SWP
- Vacuum Service to 29 in. Hg

77FLF FEATURES

- Easily Identifiable White Handle Grip and Blue "Lead Free" Hang Tag
- EZ-Solder™ Lead Free Brass
- Lead Free Dezincification Resistant Brass
- NSF/ANSI 61 Water Quality
- NSF/ANSI 372 Lead Free
- Rating: 600 CWP (1/4" - 2")
- Rating: 400 CWP (2-1/2" - 4")
- Steam Rating: 150 psi SWP
- Vacuum Service to 29 in. Hg

APPROVALS

- MSS SP-110
- IAPMO IGC-157 Ball Valves
- CGA 3.16 (125 PSI)
- CGA CR91-002 (5 PSI)
- ANSI Z21.15/CSA 9.1 (1/2 PSI)
- ASME B16.44 (5 PSI)
- ASME B16.33 (125 PSI) (1/2" - 2")
- FM 1140 (1/4" - 2")
- UL Guides: YSDT, MHKZ, YQNZ, YRBX & YRPV
- UL Guide VGGU (1/4" - 2")

OPTIONS

- (-01) Standard Lever and Trim
- (-04) 2-1/4" Stem Extension
- (-07) CS Tee Handle
- (-11) Therma-Seal™ Insulating Tee
- (-27) Stainless Steel Locking Handle
- (-50) 2-1/4" Locking Stem Extension

SEE PAGE B-30 FOR DETAILED INFORMATION

HYDRONIC & STEAM HEATING



70-100/200 SERIES
BRONZE BALL VALVE



The Apollo® 70 Series is the most widely used and trusted bronze ball valve in the industry. It features blowout-proof stem, RPTFE seats and stuffing box ring and plated brass ball.

FEATURES

- Heavy Pattern Construction
- Rated 600 psig CWP, Non-Shock
- 150 psig for Saturated Steam
- Vacuum Service to 29 in. Hg
- Adjustable Packing Gland
- Multiple Options and Configurations Available
- Lead Free Option (70LF)
- 100% Tested
- **Made in USA**

SEE PAGE B-5 FOR DETAILED INFORMATION

70-HC SERIES
CAP & CHAIN VALVE



CAP & CHAIN VALVE WITH 3/4" HOSE CONNECTION, HEAVY BRASS CAP AND REVERSE HANDLE

Ideally suited for draining or sampling of HVAC or potable water systems, these valves allow direct connections to hoses. Valve features a securely attached cover (includes chain) which prevents damage to hose threads. -200 model designed for soft soldering into lines without disassembly.

FEATURES

- Heavy Pattern Construction
- Reverse Lever is Standard for Easier Installation
- Stainless Steel Lever & Nut Standard
- NPT and Solder Connections
- EZ-Solder™ Lead Free Bronze
- ASTM B584 Bronze
- Blowout-Proof Stem Design
- RPTFE Seats and Stuffing Box Ring
- Adjustable Packing Gland
- Vacuum Service to 29 in. Hg
- Maximum Pressure: 600 psi CWP
- Temperature Rating: 200°F
- Full Pressure Rated Brass Hose Cap
- **Heavy Duty Stainless Steel Ball Chain NEW!**

SEE PAGE B-7 FOR DETAILED INFORMATION

70-10X-92 SERIES
BALL VALVE WITH STANDARD BALANCING STOP PLATE



Ideal for hydronic applications, this valve comes with a simple memory stop plate that fits over its standard lever handle. Also available with tee or round handles.

FEATURES

- Sizes 1/4" - 3"
- Chromium-Plated Ball
- RPTFE Seats and Stuffing Box Ring
- Blowout-Proof Stem
- Adjustable Packing Gland
- Rated 600 psig CWP, Non-Shock
- MSS-SP110
- CRN: 0C10908.5C
- 150 psig for Saturated Steam



77C-100-94-A SERIES

BALL VALVE WITH BALANCING STOP AND STEM EXTENSION

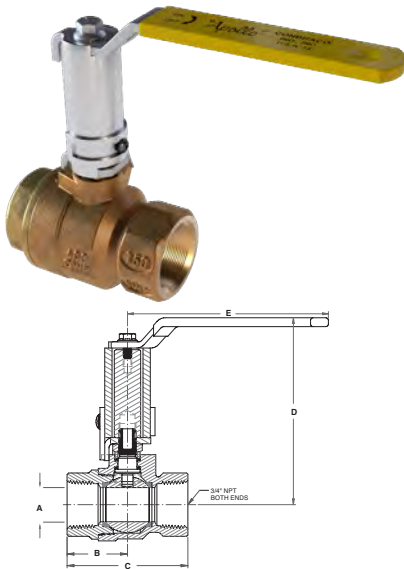

Ideal for HVAC systems. Stop plate and a 2-1/4" stem extension combination to accommodate insulation and handle repositioning.

FEATURES

- ASTM B584 Bronze
- MPTFE Seats and Stem Packing
- Blowout-Proof Stem Design
- Adjustable Packing Gland
- 600 psig CWP, Non-Shock
- Contact Customer Service for Exact Handle Dimensions and Availability.

SERIES NUMBER	LF SERIES NUMBER	SIZE (IN.)	DIMENSIONS (IN.)					NET WT. (LB.)
			A	B	C	D	E	
77C-101-94-A	77CLF-101-94-A	1/4"	0.37	1.07	2.09	3.84	3.74	0.83
77C-102-94-A	77CLF-102-94-A	3/8"	0.37	1.07	2.09	3.84	3.74	0.79
77C-103-94-A	77CLF-103-94-A	1/2"	0.50	1.15	2.25	3.87	3.74	0.87
77C-104-94-A	77CLF-104-94-A	3/4"	0.75	1.32	2.65	4.10	4.78	1.99
77C-105-94-A	77CLF-105-94-A	1"	1.00	1.53	3.07	4.29	4.78	2.16
77C-106-94-A	77CLF-106-94-A	1-1/4"	1.25	2.04	4.08	5.24	7.06	4.63
77C-107-94-A	77CLF-107-94-A	1-1/2"	1.50	2.21	4.43	5.40	7.06	5.03
77C-108-94-A	77CLF-108-94-A	2"	2.00	2.76	5.29	5.93	7.06	8.33

94A SERIES

ECONOMY FULL PORT BALL VALVE - APOLLO INTERNATIONAL™



These full port ball valves with forged brass body are UL listed and CSA approved. Ideal for general purpose non-potable applications including air, gas, HVAC, irrigation, fire protection, etc.

FEATURES

- Adjustable Stem Packing Nut
- Meets MSS SP110 Requirements
- 600 CWP Non-Shock (1/4" - 2")
- 400 CWP Non-Shock (2-1/2" - 4")
- 2-1/4" Stem Extension with Memory Stop Option (Kit)
- 100% Factory Tested
- Lead Free Option (94ALF-A)

SEE PAGE B-31 FOR DETAILED INFORMATION

95ALF SERIES

STOP & WASTE VALVE - APOLLO INTERNATIONAL™



The Apollo International™ 95ALF lead free forged brass stop and waste ball valves combine reliable operation with maximum economy. Ideal for plumbing or hydronic systems where draining is required. IAPMO listed and ANSI 3rd party certified Lead Free.

FEATURES

- Lead Free Materials and Certification
- 2 Piece, Full-Port Design
- Blowout-Proof Stem Design
- Adjustable Atem Packing Nut
- Drain Port with finger tight shut-off
- Fast, Quarter-Turn Operation

PERFORMANCE RATING

- Valve Design Rating: 600 CWP
- Temperature Range: 32°F to 250°F

APPROVALS

- IAPMO IGC 157
- ANSI/NSF 61-2011
- ANSI/NSF 372

DIMENSIONS

MODEL NUMBER	SIZE (IN.)	DIMENSIONS (IN.)				
		A	B	C	D	E
NPT						
95ALF-103-01	1/2	0.59	2.24	1.78	3.74	-
95ALF-104-01	3/4	0.79	2.53	2.09	3.94	-
95ALF-105-01	1	0.98	3.15	2.36	4.33	-

MODEL NUMBER	SIZE (IN.)	DIMENSIONS (IN.)				
		A	B	C	D	E
SOLDER						
95ALF-203-01	1/2	0.59	2.12	1.78	3.74	0.63
95ALF-204-01	3/4	0.79	2.87	1.94	3.94	0.88
95ALF-205-01	1	0.98	3.53	2.36	4.33	1.13

SEE PAGE B-33 FOR DETAILED INFORMATION

77W SERIES

APOLLOPRESS® BRONZE FULL PORT BALL VALVE



Apollo® 77W Series APOLLOPRESS® ball valves install in seconds, but the valve and the connection are made to last. Ideal for mechanical and heating systems. Not for use with natural gas.

FEATURES

- Full Port
- Ridgid® XL Press Tool Compatible
- Leak Before Press® Technology
- **300 CWP, Non-Shock to 250°F max. NEW!**
- MSS SP-110 Ball Valves
- Adjustable Stem Packing
- Excellent for Hydronic Heating (90% Glycol max)
- Popular Lever Options and Stainless Steel Trim Available
- **Made in the USA**

SEE PAGE B-34 FOR DETAILED INFORMATION

77W-HC SERIES

APOLLOPRESS® HOSE CAP & CHAIN BALL VALVE



Designed for direct mechanical connection to ASTM B88-Type K,L, and M copper tubing in the hard drawn condition for sizes 1/2"-3/4". Valves feature a 3/4" hose thread connection with heavy brass cap to protect the threads and is full pressure rated. Not for use with natural gas.

FEATURES

- Full Port
- Ridgid® XL Press Tool Compatible
- Leak Before Press® Technology
- MSS SP-110 Ball Valves
- NSF/ANSI 61 Compliant (77WLF-HC)
- **Heavy Duty Stainless Steel Ball Chain NEW!**
- Adjustable Stem Packing
- **300 CWP, Non-Shock to 250°F max. NEW!**
- Excellent for Hydronic Heating (90% Glycol max)
- Compatible with Most 77C Series Options
- Heavy Brass Dust Cover is Full Pressure Rated
- Popular Lever and Trim Options Available
- **Made in USA**

SEE PAGE B-35 FOR DETAILED INFORMATION

77V SERIES

APOLLOPRESS® BRASS BALL VALVE

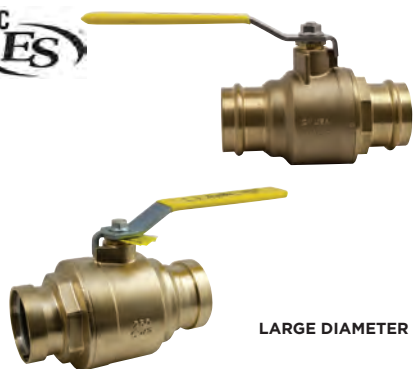

The APOLLOPRESS® 77V Series two-piece press ball valve is ideal for installation in most HVAC systems. Features Leak Before Press® technology and 250 psig maximum working pressure. Proudly Made in the USA.

FEATURES

- 2 Piece, Heavy Pattern Forged Design
- Full Port Flow
- **Max. Operating Pressure 300 psi NEW!**
- Temperature Range: 0°F - 250°F
- Superior RPTFE Seats and Packing
- Adjustable Stem packing
- Ridgid® XL Press Tool Compatible
- 2-1/2" - 4" are XLC Compatible
- Blowout-Proof Stem
- Corrosion Resistant Materials
- Silicone Free Assembly
- 100% Factory Tested
- MSS SP-110 Ball Valves
- Directive 2011/65/CE (RoHS)
- Popular Lever Options and SS Trim Available
- **Made in USA, ARRA Compliant**

SEE PAGE B-35 FOR DETAILED INFORMATION



78-RV (EXV) SERIES

SHUT-OFF VALVE W/ THERMAL EXPANSION CONTROL



The Apollo® 78RV combines thermal expansion protection and water heater shut-off in a single, simple installation. They're space saving and a less costly alternative to large expansion tanks. **Made in the USA**, featuring lead free dezincification resistant brass materials.

FEATURES

- 3/4" Solder, NPT, and PEX Ball Valve Connections
- Corrosion Resistant, Heavy Pattern, Forged Brass, Materials
- Chrome-Plated Ball
- Thermal Relief Valve is Factory Preset and Sealed
- Relief Valve Features Soft Seat and Stainless Steel Spring
- Relief Valve Available with Hose Barb, 1/2" PEX, 3/8" Compression or 1/2" Combination Solder/Thread Fitting

- Multiple Relief Pressure Kit Options
- Easily Identifiable White Handle Grip and Blue "Lead Free" Hang Tag
- EZ-Solder™ Lead Free Brass

PERFORMANCE RATING

- Maximum Temperature: 210°F

APPROVALS

- IAPMO IGC 128-2008
- City of Los Angeles Registered
- CSA B125.1 & B125.3
- NSF/ANSI 372 Lead Free

78RV	X	X	X	X	- XX
	END CONNECTION	END CONNECTION	FITTING CONNECTION	RELIEF PRESSURE (PSI)	OPTIONS**
	1 - NPT	1 - NPT	P - 1/4" PUSH	80	X2 - PEX A F1960
	2 - SOLDER	2 - SOLDER	4 - 3/8" HOSE BARB	100	BODY CONNECTION
	8 - PUSH	8 - PUSH	5 - 1/2" PEX F1807	125	
	9 - PEX F1807	9 - PEX F1807	6 - 3/8" COMPRESSION		
			7 - 1/2" NPT/SOLDER		

**If PEX F1960 is required, add -X2.

78-RV-P (EXV) SERIES

PUSH SHUT-OFF VALVE W/ THERMAL EXPANSION CONTROL



The lead free Apollo® 78-RV Series Combination Water Heater Isolation Valve/IAPMO approved Thermal Expansion Relief Device solves two code requirements while saving time, installation space and money! Features ApolloPush technology, with fast and simple "push to connect" installation. Ideal alternative to expansion tanks in residential plumbing systems. **Made in the USA**, featuring lead free dezincification resistant brass materials.

PERFORMANCE RATING

- Ball Valve Maximum Pressure: 200 psi
- Relief Valve Factory Set and Sealed at 125 psi Maximum
- Relief Valve Set Pressures: 80, 100, 125 psi
- Maximum Temperature: 210°F

APPROVALS

- IAPMO IGC 128-2008
- NSF/ANSI 372 Lead Free
- CSA B125.3

DIMENSIONS

SIZE	APOLLO PART NUMBER	EPC PART NUMBER	DIMENSIONS (IN.)			PORT DIA. (IN.)	RELIEF PRESSURE
			A	B	C		
3/4"	78RV88P80	10177548	3.9	4.2	1.6	.750	80
3/4"	78RV88P100	10177546	3.9	4.2	1.6	.750	100
3/4"	78RV88P125	10177544	3.9	4.2	1.6	.750	125

PART NUMBER MATRIX

78RV	X	X	X	XXX
	INLET CONNECTION	OUTLET CONNECTION	RELIEF CONNECTION	RELIEF PRESSURE
	8 - PUSH	8 - PUSH	P - 1/4" PUSH	80 PSI
				100 PSI
				125 PSI

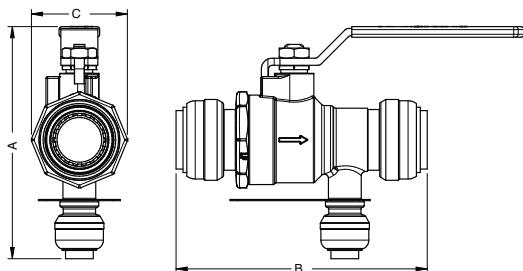

PUSH DEMOUNT TOOL

SIZE	APOLLO PART NUMBER	EPC PART NUMBER
1/2"	D514500	10165630
3/4"	D514800	10165625



GB-10 SERIES
CSA GAS SHUT-OFF VALVE



Manual shut-off valves engineered specifically for low pressure gas service. Canadian Standard Association design and capacity certified with American-made quality. High-copper content body, chrome-plated ball, and PTFE seats.

FEATURES

- (-01) Standard Die-Cast Zinc "Wing" Handle Epoxy Coated
- (-L1) Lever Handle or (-T1) Tee Handle Options
- Use with Natural, Manufactured, Mixed and Liquefied Petroleum Gases, LP Gas-Air Mixtures
- **Made in USA**

PERFORMANCE RATING

- Temperature Range: 32°F to 125°F at Pressures of 1/2 and 5 psig

APPROVALS

- Complies with ANSI Z21.15, CR91-002, and ASME 16.44

SEE PAGE B-27 FOR DETAILED INFORMATION

GB-15 SERIES
GAS APPLIANCE BALL VALVE - APOLLO INTERNATIONAL™



Designed for natural gas, manufactured and mixed gas, liquefied petroleum gases and LP gas-air mixture applications.

APPROVALS

- ANSI Z21.15 (Appliance & Hose)/CGA9.1(1/2 psi)
- ASME B16.44 (5 psi)
- UL Guide YRBX (Flammable Liquid Shut-Off)
- UL Guide MHKZ (Manual Valves)
- UL Guide YRPV (Gas Shut-Off -250#)
- UL Guide YSDT (LP Gas)

SEE PAGE B-27 FOR DETAILED INFORMATION

GB-50/GB-50A SERIES
CSA GAS SHUT-OFF VALVE



GB-50

GB-50A

Designed for "main burner" applications with cast-in single or dual pilot tap. ASTM B584 bronze body, chrome-plated ball, brass stem, retainer and gland screws for corrosion resistance.

FEATURES

- For Natural Gas, Manufactured and Mixed Gas, Liquefied Petroleum Gases and LP Gas-Air Mixtures
- Rated Pressures of 1/2 and 5 psig
- Standard Connection is FNPT x FNPT
- High BTU Capacity
- Reversible Plated Steel Lever Handle
- (-07) Tee Handle Optional

APPROVALS

- ANSI Z21.15, CGA9.1
- ASME B16.44 (2 and 5 psig)
- MSS-SP110
- UL Guide YRBX
- UL Guide MHKZ
- UL Guide YRPV
- UL Guide YSDT
- UL 125, UL 842

SEE PAGE B-28 FOR DETAILED INFORMATION



70-100-BC SERIES

BALL VALVE WITH INTEGRAL CHECK



The 70-100-BC Series ball valve combines two functions in a single design: positive shut-off and bubble-tight check capabilities. The BC Series is a unidirectional version of the industry-standard Apollo® 70 Series ball valve. An easy flow design and superior check valve make these valves a smart choice for water or air in mechanical systems or OEM applications. Rated at 250 psi CWP and maximum temperature of 200°F.

FEATURES

- Blowout-Proof Stem
- RPTFE Seats and Stuffing Box Ring
- Adjustable Packing Gland
- Chrome-Plated Ball
- Positive Shut-Off and Bubble-Tight Check Capability

SEE PAGE J-27 FOR DETAILED INFORMATION

BD90 (31-200/31-500) SERIES

90° DRAIN VALVE

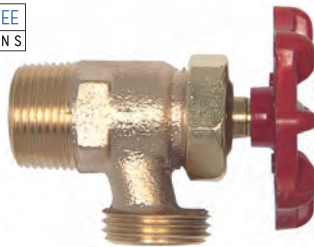

For deluxe water heaters and low pressure boilers.

FEATURES

- Maximum Rated Pressure: 200 psig
- Maximum Rated Temperature: 250°F
- Red Aluminum Wheel Handle
- 31-200 Series Heavy Pattern, 3/4" MNPT Inlet
- 31-500 Series Standard Pattern, 1/2" MNPT Inlet with I.D. of NPT Thread Machined for 1/2" Copper Pipe
- (-04P) Optional Plain Finish Handle
- **Made in USA**

SEE PAGE M-7 FOR DETAILED INFORMATION

BDQ (35-300) SERIES

BIBB FAUCET BALL VALVE



Features heavy pattern with large opening. Ideal for boiler and water heater drains, general liquid dispensing and drainage. The new 45° spout design allows for easier hose connection access.

FEATURES

- Chrome-Plated Finish
- Pressure Rating: 200 psig Liquid
- Maximum Temperature: 250°F
- Apollo International™

SEE PAGE M-8 FOR DETAILED INFORMATION



GCB (50) SERIES
MANUAL MAIN CONTROL VALVES



CSA design certified for 1/2 psig and temperatures from 32° to 125°F. Complies to ANSI Z 21.15, CSA 9.1

FEATURES

- 100% Factory Tested at 10 psig
- Bronze Construction, Stainless Steel Springs
- Capacities to 7.8 Million BTU/Hour
- Equal Female Inlet/Outlet
- Bosses on Both Sides are Drilled and Tapped. Only One Side is Plugged

SEE PAGE M-5 FOR DETAILED INFORMATION

GC (51) SERIES
GAS SERVICE COCKS



Tee or lever handle cocks; CSA design certified. In sizes 1/4" to 3/4".

FEATURES

- Capacities: 117,000 to 749,000 BTU/Hour
- Certified to ANSI Z21.15 and CSA 9.1 (1/2 psig at Temperatures from 32°F to 125°F)
- Accepted for Use by City of New York Department of Buildings MEA 45-90-M

SEE PAGE M-6 FOR DETAILED INFORMATION

GC2 (52) SERIES
GAS SERVICE COCKS



Available with tee head, flat head, square head or lever head in sizes from 1/4" to 1". Wrench operated and tested at 125 psig.

FEATURES

- High Pressure Rating
- Capacities: 117,000 to 749,000 BTU/Hour
- Accepted for Use by City of New York Department of Buildings MEA 45-90-M
- Maximum Temperature: 500°F

SEE PAGE M-6 FOR DETAILED INFORMATION



**GCR (55) SERIES
GAS COCK WITH THROTTLE ADJUSTMENT**



FEATURES

- Certified to ANSI Z21.15 and CSA 9.1 (1/2 psig at 32°F to 125°F)
- Thread Size: 1/4" Male x 1/4" Female

MODEL NUMBER	SIZE (IN.)	WT./100 (LB.)
55-302-01	1/4 M x 1/4 F	33

SEE PAGE M-6 FOR DETAILED INFORMATION

**26-100/26-300 SERIES
COMPRESSION GAUGE COCKS**

26-300



For draining expansion tanks, other liquid storage vessels. For condensate only. Standard finish is satin brass.

FEATURES

- 26-100: Rated up to 125 psig
- 26-300: Soft Metal Seat/Stuffing Box Rated up to 250 psig at 400°F
- 26-310: Stainless Steel Ball Seat/Stuffing Box Rated up to 250 psig at 400°F
- 26-700: TFE Seat, Rated up to 250 psig at 400°F

SEE PAGE M-2 FOR DETAILED INFORMATION



RP 4A SERIES
REDUCED PRESSURE PRINCIPLE

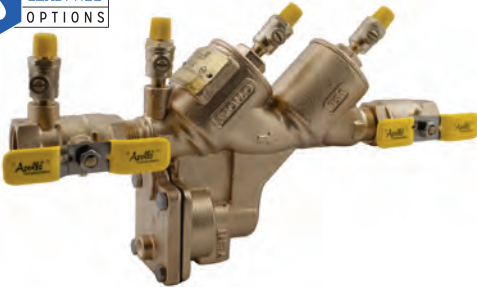

The Apollo® Series RP 4A Reduced Pressure Principle Backflow Preventer is designed to give maximum protection against backflow caused by either back-pressure or back-siphonage from substances that are hazardous. The durable but economical device is easily maintained in the line with modular check cartridge assemblies that require no special tools. It consists of two independently acting spring-loaded check valves with an automatic differential relief valve located between the check valves. All testcocks are mounted at the top of the unit to assure easy access during repair and maintenance when unit is installed in tight places.

FEATURES

- Maximum Protection Against Back-Pressure/Back-Siphonage
- Modular Check Valve Cartridges w/ Easily Replaced Parts
- Reversible/Removable Chloramine-Resistant Silicone Seat Discs
- Low Head Pressure Loss
- Top Mounted Test Cocks
- Threaded Testcock Protectors
- Internal Sensing Passage
- Modular Captured Spring Relief Valve
- ASSE 1013
- CSA B64.4
- Lead-Free Option
- NSF 61/8/G/372
- Federal Public Law 111-380
- AWWA C511
- UL, ULC Classified (T2ST Option or Less Shutoffs)
- Approved by the Foundation for Cross-Connection Control and Hydraulic Research at the University of Southern California
- Standard with Full Port Ball Valves with Stainless Steel Handles
- Corrosion Resistant
- Maximum Working Pressure: 175 psig
- Operating Temperature Range: 33°F-180°F
- Horizontal Installation Approvals on 1/2" through 2"
- 5 Year Warranty

SEE PAGE I-11 FOR DETAILED INFORMATION

AIR GAP DRAIN



For installation with RP 4A, RPDA 4A, RP 4An, RPDA 4An, and RPS 40 Series Reduced Pressure Principle backflow preventers.

The Apollo® Air Gap Drain (AGD) is designed to funnel minor relief valve discharges, due to line pressure fluctuations and /or minor check valve fouling, into the drainage system. Drain piping is easily attached to the drain's threaded bottom.

Note: The AGD is designed to collect expected minor discharges due to fouled checks or pressure fluctuations but not the full discharge capacity of the relief valve.

SEE PAGE I-19 FOR DETAILED INFORMATION

DCAP SERIES
DUAL CHECK WITH ATMOSPHERIC PORT BACKFLOW PREVENTER



The Apollo® DCAP Series Backflow Preventer is designed to protect residential and commercial water supply lines from back-siphonage or back-pressure of non-potable (non-hazardous) substances. It has an intermediate atmospheric vent to insure protection from backflow conditions. It consists of two independently acting and spring-loaded check valves in a corrosion resistant material.

FEATURES

- Corrosion Resistant
- Low Head Loss
- Independently Acting Check Valves
- Ease of Repair and Installation
- Economical
- Suitable for Hot or Cold Water Service
- Durable
- Lead Free Option
- Maximum Working Pressure: 175 psig
- ASSE 1012
- CSA B64.3
- Inlet Temperature Range: 33°F-210°F
- 5 Year Warranty
- Maximum Backflow Temperature: 250°F

SEE PAGE I-23 FOR DETAILED INFORMATION



CVBE (61-500 & 61-600) SERIES
IN-LINE SOFT SEAT CHECK VALVE



61-500
FEMALE X FEMALE THREADED
1/4" THROUGH 2"



61-600
FEMALE X FEMALE SWEAT
1/2" THROUGH 2"

The Apollo® Model CVBE check valve is ideally suited for hydronic heating and other low flow applications. The rugged bronze body and check provide reliable protection against reverse flow.

FEATURES

- Female NPT Sizes: 1/4" to 2"
- Stainless Steel Sizes: 1/4" to 1"
- Bubble-Tight Shut-Off, Ideally Suited for Gaseous Service
- NPT Threaded; 400 psig CWP Non-Shock @ 100°F
- EPDM Check Disc (61-500)
- Viton® Check Disc (62-500)
- Straight-Through Design Minimizes Pressure Loss
- 1/2 psi Cracking Pressure
- RoHS Compliant (61LF and 62 Series)

SEE PAGE J-24 FOR DETAILED INFORMATION

CVSE (62-500) SERIES
IN-LINE SOFT SEAT CHECK VALVE



The Apollo® Model CVSE is ideal for fluid flow applications in tough industrial environments. The stainless steel body and check provide lasting protection against reverse flow.

FEATURES

- Bubble-Tight Shut-Off, Ideally Suited for Gaseous Service
- 400 psig CWP non-shock
- Viton® Check Disc
- Approximate Opening Pressure 1/2 psi
- RoHS Compliant
- CRN OC 11218.5C

SEE PAGE J-25 FOR DETAILED INFORMATION



MODEL 101S/101S-LF
SOLDER END RISING STEM GATE VALVE



FEATURES

- Threaded Bonnet
- Solid Bronze Disc
- 200 CWP
- Max. Temp: 406°F
- Lead Free Option (NSF 61/NSF 372)

STANDARDS

- MSS SP-80 Standard
- MSS SP-139 Lead Free Option (CWP only)
- ASTM B62 Bronze (ASTM B584-C89836 Lead Free)

SEE PAGE J-2 FOR DETAILED INFORMATION

MODEL 101T/101T-LF
NPT END RISING STEM GATE VALVE



FEATURES

- Threaded Bonnet
- Solid Bronze Disc
- 200 CWP
- 125 SWP
- Max. Temp: 406°F
- Lead Free Option (NSF 61/NSF 372)

STANDARDS

- MSS SP-80 Standard
- MSS SP-139 Lead Free Option (CWP only)
- ASTM B62 Bronze (ASTM B584-C89836 Lead Free)

SEE PAGE J-2 FOR DETAILED INFORMATION

MODEL 102S/102S-LF
SOLDER END RISING STEM GATE VALVE



FEATURES

- Threaded Bonnet
- Solid Bronze Disc
- 200 CWP
- Max. Temp: 406°F
- Lead Free Option (NSF 61/NSF 372)

STANDARDS

- MSS SP-80 Standard
- MSS SP-139 Lead Free Option (CWP only)
- ASTM B62 Bronze (ASTM B584-C89836 Lead Free)

SEE PAGE J-2 FOR DETAILED INFORMATION

MODEL 102T/102T-LF
NPT END NON-RISING STEM GATE VALVE



FEATURES

- Threaded Bonnet
- Solid Bronze Disc
- 200 CWP
- 125 SWP
- Lead Free Option (NSF 61/NSF 372)

STANDARDS

- MSS SP-80 Standard
- MSS SP-139 Lead Free Option (CWP only)
- ASTM B62 Bronze (ASTM B584-C89836 Lead Free)

SEE PAGE J-3 FOR DETAILED INFORMATION



MODEL 161S/161S-LF BRONZE DISC SWING CHECK



FEATURES

- Y-Pattern
- Solder Ends
- Metal Seat
- 200 CWP
- Lead Free Option (NSF 61/NSF 372)

STANDARDS

- MSS SP-80 Standard
- MSS SP-139 Lead Free Option (CWP only)
- ASTM B62 Bronze (ASTM B584-C89836 Lead Free)

SEE PAGE J-10 FOR DETAILED INFORMATION

MODEL 161T/161T-LF CLASS 125 BRONZE DISC SWING CHECK



FEATURES

- Y-Pattern
- NPT
- Metal Seat
- 200 CWP
- 125 SWP
- Lead Free Option (NSF 61/NSF 372)

STANDARDS

- MSS SP-80 Standard
- MSS SP-139 Lead Free Option (CWP only)
- ASTM B62 Bronze (ASTM B584-C89836 Lead Free)

SEE PAGE J-10 FOR DETAILED INFORMATION

59 (YB) SERIES
BRONZE WYE STRAINER



Heavy pattern design with large area screens ensures excellent protection against foreign particles in your fluid system. Corrosion-resistant bronze body and stainless steel screens provide years of service.

FEATURES

- Sizes 1/8" to 4" NPT
- Replaceable Self-Aligning Screen
- Large Net Flow Area for Longer Maintenance Intervals
- 59-400 Series is Female x Male NPT (3/4" & 1" Only)
- Blow-Off Ball Valve Option (3/4" - 2")
- Several Screen and Cap Options
- **Made in USA, ARRA Compliant**

PERFORMANCE RATING

- Working Pressure:
CWP: 400 psi (up to 3")
SWP: 125 psi
- Maximum Temperature: 350° F

APPROVALS

- NSF/ANSI 372 Lead Free (59LF)
- CRN-0E 8959.5

SEE PAGE K-2 FOR DETAILED INFORMATION

59-300 (YBS) SERIES
BRONZE WYE STRAINER - SOLDER



Heavy pattern design with large area screens ensures excellent protection against foreign particles in your fluid system. Corrosion-resistant bronze body and stainless steel screens provide years of service.

FEATURES

- Sizes 1/2" to 3" Copper Tube Size
- Optional Tapped Caps Available
- 59LF features EZ-Solder™ Bronze
- **Made in USA**

PERFORMANCE RATING

- Working Pressure:
CWP: 200 psi (up to 3")
SWP: 125 psi
- Maximum Temperature: 350° F

APPROVALS

- NSF/ANSI 372 Lead Free (59LF)

SEE PAGE K-4 FOR DETAILED INFORMATION

YCT SERIES
CAST IRON WYE STRAINER - APOLLO INTERNATIONAL™



Install these durable strainers upstream in almost any application to protect valves, regulators, solenoids and meters from rust, dirt and pipe scale.

FEATURES

- 20 Mesh Screens Standard to 2"; .045 perf. 2-1/2" to 3", Others Available
- Graphite Gasketed Cover for Easy Screen Cleaning
- Standard Tapped Cap with Plug
- Sizes: 1/4" to 3"
- Connections are NPT to ASME/ANSI B1.20.1
- NSF Approved Epoxy Coating

PERFORMANCE RATING

- Working Pressure:
CWP: 500 psi
SWP: 250 psi
- Maximum Temperature: 406° F

APPROVALS

- NSF/ANSI 372 Lead Free

SEE PAGE K-5 FOR DETAILED INFORMATION



EXT (16XT) SERIES

EXPANSION TANKS FOR HYDRONIC (NON-POTABLE) SYSTEMS



Apollo® non-potable expansion tanks help maintain balanced pressure throughout a hot water heating system by absorbing thermal expansion. Pre-pressurized, they're designed to prevent system damage and unnecessary discharges by relief valves and ensure long, trouble-free system life.

FEATURES

- Chlorobutyl Diaphragm
- Durable Triple-Coated Epoxy Grey Finish
- Field Adjustable Charge
- Hex Flat NPT Connection
- Vertical or Horizontal Mount
- Glycol Compatible
- Drawn Steel Construction
- Maximum Pressure: 150 psi
- Maximum Temperature: 200° F
- Pre-Charge Pressure: 12 psig

MODEL NUMBER	PART NUMBER	CAPACITY (GAL.)	EXP. VOLUME (GAL.)	CONNECTION SIZE (NPT)	DIAMETER (IN.)	HEIGHT (IN.)	WEIGHT (LB.)
EXT2	16XT1-04	2.10	0.9	1/2	8.0	12.5	4.25
EXT5	16XT3-04	4.5	2.5	1/2	11.0	15.0	7.5
EXT7	16XT5-04	6.0	3.0	1/2	11.5	16.63	8.75
EXT14	16XT7-04	14.0	11.3	1/2	15.5	23.5	19

EXTP (40XT) SERIES

EXPANSION TANKS FOR POTABLE SYSTEMS



Designed to protect closed water supply systems, appliances and piping from the hazards of thermal expansion, such as premature water heater failure. Installs easily on direct fired gas, oil and electric hot water heaters and storage tanks. Their pre-pressurized steel design includes an expansion membrane that stops any contact between the water and air in the tank.

FEATURES

- Food Quality Chlorobutyl Diaphragm
- Drawn Steel Construction
- Durable Triple-Coated Epoxy Almond Finish
- Field Adjustable Pressure Setting
- Corrosion Resistant Liner Connection
- Maximum Pressure: 150 psi
- Maximum Temperature: 200° F
- Pre-Charge Pressure: 35 psig

APPROVALS

- NSF/ANSI 61 Water Quality
- IAPMO

MODEL NUMBER	PART NUMBER	CAPACITY (GAL.)	EXP. VOL- UME (GAL.)	CONNECTION SIZE (NPT)	DIAMETER (IN.)	HEIGHT (IN.)	WEIGHT (LB.)
EXTP2	40XT1-04	2.10	0.9	3/4	8.0	12.5	4.7
EXTP5	40XT3-04	4.5	2.5	3/4	11.0	15.0	8
EXTP10	40XT5-04	10	5.2	3/4	11.5	20	13.5

Maximum expansion volume is based on 35 psi.

HYDRONIC & STEAM HEATING

27-400 SERIES
STEAM GAUGE SIPHON

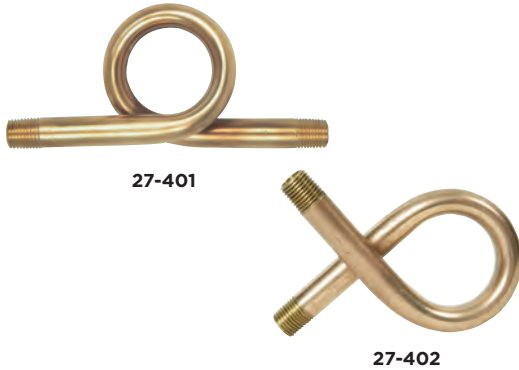

For pressure gauge protection. Condensate trap protects dial pressure gauges from direct steam contact.

FEATURES

- Heavy Gauge Seamless Brass Tubing
- 27-401 is 180° loop, 27-402 is 90° loop
- Service Rating: 250 psig Saturated Steam, 400 psig at 100°F

SEE PAGE M-3 FOR DETAILED INFORMATION

20-100 SERIES
STANDARD PATTERN BRONZE WATER GAUGES



Use for all types of liquid level verification; available with 3/8" or 1/2" NPT male pipe connections. Aluminum or plastic composition hand wheels; EPDM gauge glass gaskets standard. Other glass gaskets available.

FEATURES

- Ball Checks Standard on **20-150** Models
- Equipped with Two Copper Guard Rods
- Standard 1/4" Needle Drain Valve in Lower Arm
- Rated: 125 psig @ 350°F, 300 psig @ 100°F
- CRN Registered

SEE PAGE L-10 FOR DETAILED INFORMATION

HYDRONIC &
STEAM HEATING

27-200 (RAV) SERIES
RADIATOR AIR VALVE - APOLLO INTERNATIONAL™

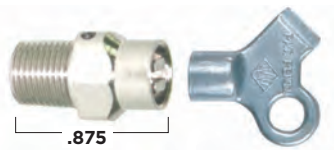

Manual air purge valves for hot water radiators/heating systems.

SERIES NUMBER	SIZE	NET WT. (LB.)
27-202-02	1/8 NPT	2.0
H-2404-00	Key only	0.9



BASIC HEAT TRANSFER CALCULATION

$$q \left(\frac{\text{Btu}}{\text{hr}} \right) = \dot{m} c_p \Delta t$$

$$\frac{\text{Btu}}{\text{hr}} = \left| \frac{\text{lb}}{\text{hr}} \right| \left| \frac{\text{Btu}}{\text{lb.} \cdot ^\circ\text{F}} \right| \left| \right|$$

$$q \left(\frac{\text{Btu}}{\text{hr}} \right) = Q \ 500 \ c_p \ \Delta t$$

$$q \frac{\text{Btu}}{\text{hr}} = \left| \frac{Q \text{ Gal}}{\text{min}} \right| \left| \frac{60 \text{ min}}{\text{hr}} \right| \left| \frac{8.34 \text{ lb}}{\text{Gal}} \right| \left| \frac{\text{Btu}}{\text{lb.} \cdot ^\circ\text{F}} \right| \left| \right|$$

q = heat transfer (Btu/hr.)
Q = flow rate (gpm)
cP = specific heat of fluid
Δt = change in fluid temperature °F

FLOW RATE CALCULATION BASED ON C_v

$$Q = C_v \sqrt{\frac{\Delta P}{SG}}$$

Q = flow rate (gpm)
CV = device flow coefficient
ΔP = change in fluid pressure across the device (psi)
SG = Specific Gravity of fluid

Energy:
1 Watt hour = 3.413 btu 1 Kilowatt hour = 3,413 btu
1 Therm = 100,000 btu 1MMBtu = 1,000,000 btu

Power and Heat Flow:
1 Kilowatt = 3,413 btu/hr 1 Ton = 12,000 btu/hr
1 Horsepower = 0.746 kilowatt = 2546 btu/hr

Temperature:
°C = (°F - 32)/1.8 °F = (°C x 1.8) + 32

Weight and Volume:
1 Gal water = 8.34 lbs
1 Cubic foot water = 62.4 lbs
1 Cubic foot water = 7.482 gal

SYSTEM CURVE (CIRCULATOR PERFORMANCE)

$$\left(\frac{Q_2}{Q_1} \right)^2 = \left(\frac{h_2}{h_1} \right)$$

$$\left(\frac{Q_2}{Q_1} \right)^3 = \left(\frac{P_2}{P_1} \right)$$

Q = flow rate at known or new condition (gpm)
h = change in fluid head (pressure) (psi or feet head)
P = work to move fluid (pumping horsepower)

PRESSURE VS. HEAD CONVERSION

$$\frac{\text{Area}}{\rho} = 2.31 \frac{\text{ft}}{\text{psi}}$$

$$\left| \frac{\text{Ft}^3}{62.4 \text{ lb.}} \right| \left| \frac{144 \text{ in}^2}{1 \text{ Ft}^2} \right| = 2.31 \frac{\text{ft}}{\text{psi}}$$

Relationship of Water Pressure in Feet to PSI
ρ = fluid density (lb/ft³)
Head incorporates velocity and static pressure and is typically used for expressing pressure (and pump energy) on pump curves in hydronic systems

POWER CURVE (CIRCULATOR PERFORMANCE)

$$P_{HP} = \frac{Q \times h}{3960 \times \eta_p}$$

P_{HP} = pumping horsepower (work to move fluid)
Q = flow rate at operating condition (gpm)
h = fluid head (feet head)
η_p = pump efficiency at operating point

Steam Conversion Factors:
Boiler horsepower (BHP) x 34.5 = lb. of steam water per hr. (lb/hr)
Boiler horsepower (BHP) x 0.069 = Gal of water per minute (gpm)

Making or Melting Ice:
Latent Heat of Fusion - Requires 143.5 btu per lb. at 32°F

Heating or Cooling Liquid Water:
Sensible Heat - Requires 1 btu per lb. per °F

Vaporizing Water (Steam):
Latent Heat of Vaporization - Requires 970 btu per lb. at 14.7 psia

Heat from Combustion:
Natural Gas (Typical) - 1000 btu per cubic foot
Propane - 2550 per cubic foot
No. 2 Fuel Oil - 138,000 btu per gallon



FRICTION	0.85 FT/100	4.5 FT/100	HEAT TRANSFER CAPACITY			
			STEEL PIPE SIZE	MIN FLOW GPM	MAX FLOW GPM	BTU/HR 20° ΔT
½"	0.75	2	20,000	50,000	12,000	1.00
¾"	1.5	4.25	42,500	106,250	25,500	2
1"	4	8.5	85,000	212,500	51,000	4.25
1¼"	7	17	170,000	425,000	102,000	8.5
1½"	10.5	26	260,000	650,000	156,000	13
2"	20	50	500,000	1,250,000	300,000	25
3"	60	145	1,450,000	3,625,000	870,000	72.5
4"	120	300	3,000,000	7,500,000	1,800,000	150
5"	220	525	5,250,000	13,125,000	3,150,000	262.5
6"	350	850	8,500,000	21,250,000	5,100,000	425
8"	700	1800	18,000,000	45,000,000	10,800,000	900
10"	1300	3300	33,000,000	82,500,000	19,800,000	1650
12"	2100	5250	52,500,000	131,250,000	31,500,000	2625

"Apollo"®

34ALF-200	G-4
34BLF-200/300	G-6
34C - 34CLF	G-8
34DLF-300	G-10
34-200	G-11
34HL	G-12
34E - 34ELF	G-14
ACCESSORIES	G-15

MIXING VALVES



34-200 SERIES



Apollo® 34 Series Mixing Valves help extend hot water supply and enhance the life and accuracy of hydronic thermostats in residential and small commercial systems. These valves may be used to increase draw capacity of automatic storage water heaters. They save hot water and energy by automatically regulating the mix of hot water with cold. Water temperatures can be adjusted by simply turning the yellow knob to the desired setting.

- Sizes 1/2", 3/4"; Solder
- Corrosion Resistant Bronze Body and Stainless Steel Spring
- Easy Installation
- For Tankless Coils, Water Heaters, Boilers and Solar Energy Systems
- Outlet Temperatures from 120° to 130°F (110° to 150°F Optional)

34A-LF SERIES



Apollo® 34A-LF Series Mixing Valves provide thermostat control of temperatures in residential, commercial and non-potable hot water systems. They are ASSE 1017 certified and designed for use with water heaters and boilers. During operation, the valve redistributes and extends safe hot water from the heater to various sections of a building's water system. 34A-LF Series mixing valves offer integral checks to prevent cross-connection of temperatures. They also enable the contractor to direct mount the unit to the heater or boiler instead of heat trapping the valve.

- Sizes 1/2", 3/4", 1"
- Highest Flow Capacity in its Class
- Maximum Rated Working Pressure of 125 psig
- Easy Temperature Control From 85° to 140°F
- Corrosion Resistant Cast Bronze Body
- Integral Checks
- Union Tailpieces and Union Nuts Standard
- NPT, Solder, CPVC, Press, Push and PEX Connections
- Easily Accessible Internals Allow In-Line Servicing
- Glass-Filled Noryl® Shuttle

34ALF-H SERIES



Apollo® 34ALF-H Series Mixing Valves are ideal for use with domestic and commercial boilers and all types of radiant systems. They are available in a variety of pipe end connections and are equipped with element over-travel protection. Also the 34H Series mixing valves offer integral checks to prevent cross-connection of temperatures.

- Sizes 1/2", 3/4", 1"
- Maximum Rated Working Pressure of 125 psig
- Mixed Temperature Range of 120° to 180°F
- Corrosion Resistant Cast Bronze Body
- Union Tailpieces and Union Nuts, Standard
- Designed to Make Maintenance Fast and Easy
- Glass-Filled Noryl® Shuttle

34B-LF SERIES



Apollo® 34B-LF Series thermostatic mixing valves are mixing valves are triple ASSE 1017, ASSE 1069, and 1070 certified for point-of-use applications and provide enough capacity to protect up to twelve separate fixtures while maintaining an accuracy of +/- 3°F. They offer easy adjustment of water temperatures. In accordance with ASSE 1070 standards, Series 34B valves come with maximum set point control features.

- Sizes 1/2", 3/4", 1"
- Controlled Temperatures from Full Cold up to 120°F.
- Corrosion Resistant Bronze Body
- Union Tailpieces and Nuts Standard
- NPT, Solder, CPV, Push, PEX Connections
- In-Line Repairable
- Glass-Filled Noryl® Shuttle
- Factory Equipped with Integral Checks and Strainers
- Locking Cap Feature



34CLF SERIES



Apollo® 34CLF Series high capacity mixing valves are ASSE 1017 certified. Also available in a high temperature model, these large capacity valves are designed for use in large commercial and institutional hot water systems.

- Sizes 3/4" - 2"
- Industry Leading Flow Rates
- Corrosion Resistant Cast Bronze Body
- Stainless Steel and Thermoplastic Internals
- Maximum Rated Pressure of 150 psig
- All Replaceable Parts Accessible from Single Point
- Controlled Temperature Range of 90° to 140° F (130° to 180° F Optional - "H" Model non-ASSE)
- In-Line Repairable
- Glass-Filled Noryl® Shuttle
- Optional Non Lead Free for Non-Potable Water

34D-LF SERIES



Apollo® 34D Series Thermostatic "Mini Mixer" Valves are dual ASSE 1070 certified and designed as the ultimate single fixture valve, with a mixed accuracy of +/- 2°F. Two designs are available depending on the application; single outlet design for sensor type faucets and double outlet design for standard connections.

- Compact, Space Saving Design
- 3/8" x 3/8" Compression Connections
- Factory Equipped with Integral Checks
- Corrosion Resistant Cast Bronze Body
- Stainless and Thermoplastic Internals
- Bypass Tee Option for Cold Water Connection
- Chrome Plating Option

34E/34E-LF SERIES



Apollo® 34E Emergency Mixing Valves are designed to control the cold and hot water temperature to deliver tepid water at a predetermined temperature to emergency eyewash/facewash fixtures. The device provides a precise temperature and flow control in the event of cold water, hot water and thermostatic element failures. Complies with ANSI Z358.1-2009 & ASSE 1071-2008.

- Hot and Cold Water Supply Failure Protection Patented Design (US Patent 6,926,20 B2)
- Tepid Water Temperature Limit Control and Adjustment
- Tepid Water Temperature Adjustment Handle with Locking Mechanism for Tamper-Resistant Protection and Inadvertent Adjustment
- Integral Inlet Check Valves and Strainers to Provide Protection Against Cross-Flow And Foreign Particles
- Superior Thermostatic Element Technology for Optimum Reliability, Dependability and Accuracy
- Thermostatic Element Failure and Over-Travel Protection
- High Efficiency and Positive Shut-Off Check Valves
- In-Line Accessibility and Serviceability of Failure Protection Module and Mixing Valve Internal Components
- Meets the Requirements of the EPA Safe Drinking Water Act
- Corrosion Resistant Components
- Single Cartridge Design of Failure Protection Module for Easy Service and Maintenance

34HL SERIES



Apollo® 34HL High/Low Mxing Valve is a single assembly that controls mixed water temperatures to multiple-outlet shower and sink installations. It's the ideal choice in new construction or retrofits in nursing homes, prisons, hospitals, schools, gymnasiums, airports and other facilities where constant safe water temperature needs to be maintained at several outlets without the use of independent ASSE 1016 shower valves.

- Capable of Maintaining Safe, Consistent Temperature Control of Water at Low and High Flows to Within ± 3.6° F
- Provides Consistent Temperature Control at Flow Rates as High as 60 GPM and as Low as 1.5 GPM, Including Mid-Range Flow Between High and Low
- Does Not Require Recirculation Pumps Like Other Systems in Order to Achieve Low Flow Control
- Integral Strainers and Checks are Provided at the Hot and Cold Supply Inlets for Greater Reliability and Performance
- Units Can Be Mounted in Parallel for Extra Large Flow Requirements

MIXING VALVES



MVA-LF (34ALF SERIES)/MVAH HYDRONIC SERIES
POINT OF SOURCE THERMOSTATIC MIXING VALVE



Apollo® 34ALF Thermostatic Master Mixing Valves are designed for ASSE 1017 "point of source" applications. They provide reliable hot water temperature control of potable and hydronic hot water distribution systems.



FEATURES

- Superior Thermostatic Element Technology For Optimal Performance, Reliability and Accuracy
- Integral Inlet Strainers and Check Valves are Standard to Protect Against Cross-Flow and Foreign Particles in the Piping System
- Thermostat Over-Temperature Control
- Maximum Temperature Limit Option
- Fingertip Temperature Control
- Cold or Hot Water Supply Failure Shut-Off Protection
- Multiple Connection Options to Fit Your Specific Needs
- High Temperature Version For Hydronic/Radiant Heating Applications
- Lead Free Construction Certified: 0.25% Lead max
- **Made in USA - ARRA compliant**

OPTIONS

- **PEX A F1960 Tailpieces** **NEW!**
- (-B) Temperature Limit Stop (120° F max)
- High Temp Range (H) Radiant Heat Application 120°F - 180°F (Not ASSE Certified) See 34A-H Submittal Sheet

STANDARD MATERIAL LIST

BODY	C89836 Lead Free Bronze
SHUTTLE	Noryl® Modified PPO (Polyphenylene Oxide)
SENSOR	Copper/Wax Filled
O-RING	Chloramine Resistant EPDM
SPRING	ASTM A313 Stainless Steel
CAP	ABS (Acrylonitrile Butadiene Styrene)

APPROVALS

- ASSE 1017 - Temperature Actuated Mixing Valve for Hot Water Distribution Systems
- CSA B125.3 - Plumbing Supply Fittings
- NSF/ANSI 372 - Lead Free

DIMENSIONS

SERIES NO.	CONNECTION	SIZE (IN.)	DIMENSIONS (IN.)						UNIT WT. (LB.)
			A	B	C	D	E	F	
34ALF213T	Thread - FNPT	1/2	3.73	2.11	2.28	4.56	1.87	0.95	2.75
34ALF213S	Solder		3.73	2.11	2.28	4.56	1.87	0.93	2.54
34ALF213C	CPVC		3.73	2.11	2.28	4.56	1.87	0.70	2.39
34ALF213X2	PEX A		3.73	2.11	2.28	4.56	1.87	1.20	2.54
34ALF213X	PEX B/C		3.73	2.11	2.28	4.56	1.87	1.02	2.54
34ALF213PR	Press		3.73	2.11	2.28	4.56	1.87	0.99	2.60
34ALF213P	Push		3.73	2.11	2.28	4.56	1.87	1.23	2.94
34ALF214T	Thread - FNPT	3/4	3.73	2.11	2.28	4.56	1.87	0.93	2.84
34ALF214S	Solder		3.73	2.11	2.28	4.56	1.87	0.93	2.60
34ALF214C	CPVC		3.73	2.11	2.28	4.56	1.87	0.92	2.42
34ALF214X2	PEX A		3.73	2.11	2.28	4.56	1.87	1.20	2.60
34ALF214X	PEX B/C		3.73	2.11	2.28	4.56	1.87	1.25	2.60
34ALF214PR	Press		3.73	2.11	2.28	4.56	1.87	1.14	2.65
34ALF214P	Push		3.73	2.11	2.28	4.56	1.87	1.78	3.08
34ALF215T	Thread - FNPT	1	3.73	2.11	2.28	4.56	1.87	1.06	2.93
34ALF215S	Solder		3.73	2.11	2.28	4.56	1.87	1.06	2.66
34ALF215C	CPVC		3.73	2.11	2.28	4.56	1.87	1.16	2.45
34ALF215X2	PEX A		3.73	2.11	2.28	4.56	1.87	1.17	2.66
34ALF215X	PEX B/C		3.73	2.11	2.28	4.56	1.87	1.55	2.66
34ALF215PR	Press		3.73	2.11	2.28	4.56	1.87	1.18	2.71
34ALF215P	Push		3.73	2.11	2.28	4.56	1.87	1.96	3.29

* PEX A (ASTM F1960) Cold Expansion PEX
** PEX B/C (ASTM F1807) Crimp PEX

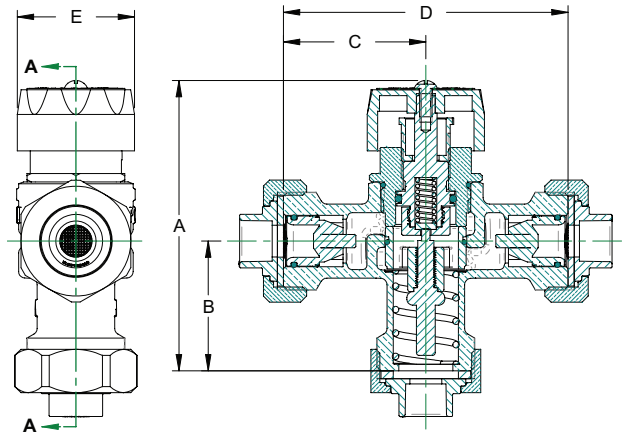

TAILPIECES

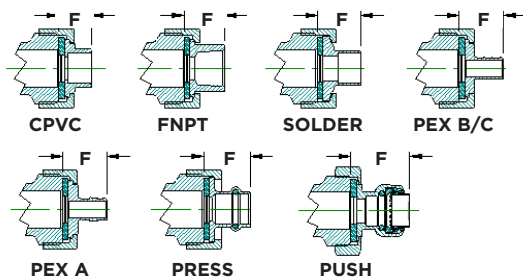



MVA-LF (34ALF SERIES)/MVAH HYDRONIC SERIES
POINT OF SOURCE THERMOSTATIC MIXING VALVE

PERFORMANCE RATING

- Maximum Working Pressure: 150 psig (1034 kPa)
- Maximum Working Temperature: 210°F (99°C)
- Cold Water Inlet Temperature Range: 39°-80°F (4° - 27°C)
- Hot Water Inlet Temperature Range: 120° - 200°F (49° - 82°C)
- Minimum Flow Rate: 1/2 gpm (1.9 lpm)
- Mixed Water Temp. Range - Standard: 85° - 120°F
- Mixed Water Temp. Range - High: 120° - 180°F
- Mixed Water Temperature Tolerance: ±5°F (1.7°C)
- Flow Rate at 30 psig (138 kPa): 19 gpm (64 lpm)
- Maximum Pressure Differential Between Hot & Cold: 25%

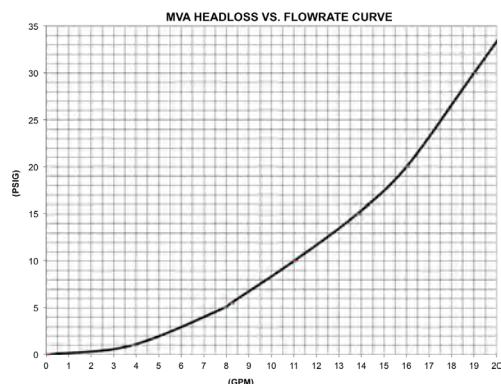

SIZE (IN.)	CONNECTION	STANDARD TEMP (85° - 140°F)		CAL. MAX. TEMP (120°F)		RADIANT	
		MODEL NO.	ORDER NO.	MODEL NO.	ORDER NO.	HIGH TEMP (120° - 180°F)*	
						MODEL NO.	ORDER NO.
1/2"	Solder inlets x Solder outlet	MVAS12LF	34ALF213S	MVABS12LF	34ALF213BS	MVAHS12LF	34ALF213HS
	FNPT inlets x FNPT outlet	MVA12LF	34ALF213T	MVAB12LF	34ALF213BT	MVAH12LF	34ALF213HT
	CPVC inlets x CPVC outlet	MVAC12LF	34ALF213C	MVABC12LF	34ALF213BC	-	-
	PEX A inlets x PEX A outlet	MVAX212LF	34ALF213X2	MVABX212LF	34ALF213BX2	-	-
	PEX B/C inlets x PEX B/C outlet	MVAX12LF	34ALF213X	MVABX12LF	34ALF213BX	-	-
	Solder inlets x CPVC outlet	MVASC12LF	34ALF213SC	MVABSC12LF	34ALF213BSC	-	-
	FNPT inlets x CPVC outlet	MVATC12LF	34ALF213TC	MVABTC12LF	34ALF213BTC	-	-
	PEX B/C inlets x CPVC outlet	MVACX12LF	34ALF213XC	MVABXC12LF	34ALF213BXC	-	-
	CPVC inlets x PEX B/C outlet	MVACX12LF	34ALF213CX	MVABXC12LF	34ALF213BCX	-	-
	PRESS inlets x PRESS outlet	MVAPR12LF	34ALF213PR	MVABPR12LF	34ALF213BPR	-	-
PUSH inlets x PUSH outlet	MVAP12LF	34ALF213P	-	-	-	-	
3/4"	Solder inlets x Solder outlet	MVAS34LF	34ALF214S	MVABS34LF	34ALF214BS	MVAHS34LF	34ALF214HS
	FNPT inlets x FNPT outlet	MVA34LF	34ALF214T	MVAB34LF	34ALF214BT	MVAH34LF	34ALF214HT
	CPVC inlets x CPVC outlet	MVAC34LF	34ALF214C	MVABC34LF	34ALF214BC	-	-
	PEX A inlets x PEX A outlet	MVAX234LF	34ALF214X2	MVABX234LF	34ALF214BX2	-	-
	PEX B/C inlets x PEX B/C outlet	MVAX34LF	34ALF214X	MVABX34LF	34ALF214BX	-	-
	Solder inlets x CPVC outlet	MVASC34LF	34ALF214SC	MVABSC34LF	34ALF214BSC	-	-
	FNPT inlets x CPVC outlet	MVATC34LF	34ALF214TC	MVABTC34LF	34ALF214BTC	-	-
	PEX B/C inlets x CPVC outlet	MVACX34LF	34ALF214XC	MVABXC34LF	34ALF214BXC	-	-
	CPVC inlets x PEX B/C outlet	MVACX34LF	34ALF214CX	MVABXC34LF	34ALF214BCX	-	-
	PRESS inlets x PRESS outlet	MVAPR34LF	34ALF214PR	MVABPR34LF	34ALF214BPR	-	-
PUSH inlets x PUSH outlet	MVAP34LF	34ALF214P	-	-	-	-	
1"	Solder inlets x Solder outlet	MVAS1LF	34ALF215S	MVABS1LF	34ALF215BS	MVAHS1LF	34ALF215HS
	FNPT inlets x FNPT outlet	MVA1LF	34ALF215T	MVAB1LF	34ALF215BT	MVAH1LF	34ALF215HT
	CPVC inlets x CPVC outlet	MVAC1LF	34ALF215C	MVABC1LF	34ALF215BC	-	-
	PEX A inlets x PEX A outlets	MVAX21LF	34ALF215X2	MVABX21LF	34ALF215BX2	-	-
	PEX B/C inlets x PEX B/C outlets	MVAX1LF	34ALF215X	MVABX1LF	34ALF215BX	-	-
	Solder inlets x CPVC outlet	MVASC1LF	34ALF215SC	MVABSC1LF	34ALF215BSC	-	-
	FNPT inlets x CPVC outlet	MVATC1LF	34ALF215TC	MVABTC1LF	34ALF215BTC	-	-
	PEX B/C inlets x CPVC outlet	MVACX1LF	34ALF215XC	MVABXC1LF	34ALF215BXC	-	-
	CPVC inlets x PEX B/C outlet	MVACX1LF	34ALF215CX	MVABXC1LF	34ALF215BCX	-	-
	PRESS inlets x PRESS outlet	MVAPR1LF	34ALF215PR	MVABPR1LF	34ALF215BPR	-	-
PUSH inlets x PUSH outlet	MVAP1LF	34ALF215P	-	-	-	-	

* High temperature models are not ASSE certified.
 ** PEX A (ASTM F1960) Cold Expansion PEX
 *** PEX B/C (ASTM F1807) Crimp PEX

MIXING VALVES



MVB-LF (34BLF SERIES)

POINT OF USE THERMOSTATIC MIXING VALVE



Apollo® Model MVB-LF (34B-LF Series) Thermostatic Mixing Valves are designed to control and limit the volumes of cold and hot water required to deliver mixed water at a predetermined safe temperature either from the “point of source” or “point of use” application for single or multiple fixtures.

FEATURES

- Now Certified to Meet ASSE 1069
- Highest Capacity That Meets ASSE 1070
- Superior Thermostatic Element Technology for Optimum Reliability, Dependability and Accuracy
- Integral Strainers and Check Valves Provide Protection Against Cross-Flow and Foreign Particles
- Thermostat Over-Temperature Protection
- Tamper Resistant Locking Cap Feature
- Maximum Temperature Setting Adjustment
- Instantaneous Cold or Hot Water Supply Failure Shut-Off Protection
- Multiple Connection Options to Fit Your Specific Needs
- Lead Free Construction Certified: 0.25% Lead max
- **PEX A F1960 Tailpieces Available NEW!**
- **Made in USA - ARRA Compliant**

APPROVALS

- ASSE 1017 - Temperature Actuated Mixing Valve for Hot Water Distribution Systems
- ASSE 1069 - Automatic Temperature Control Mixing Valves
- ASSE 1070 - Water Temperature Limiting Device
- CSA B125.3 - Plumbing Supply Fittings
- NSF/ANSI 372 - Lead Free

PERFORMANCE RATING

- Maximum Supply Pressure: 150 psig (1034 kPa)
- Maximum Working Temperature: 210°F (99°C)
- Cold Water Inlet Temperature Range: 39° - 80°F
- Hot Water Inlet Temperature Range: 120° - 180°F (49° - 82°C)
- Mixed Water Temperature Range: 80° - 120°F (27° - 49°C)
- Mixed Water Temperature Tolerance: ± 3°F (1.7°C)
- Minimum Flow Rate: 0.5 gpm (1.9 lpm)
- Maximum Pressure Differential Between H/C: 25%
- Minimum Inlet/Outlet Temperature Differential: 10°F

STANDARD MATERIAL LIST

BODY	C89836 Lead Free Bronze
SHUTTLE	Noryl® Modified PPO (Polyphenylene Oxide)
SENSOR	Copper/Wax Filled
O-RING	Chloramine Resistant EPDM
SPRING	ASTM A313 Stainless Steel
CAP	ABS (Acrylonitrile Butadiene Styrene)

MIXING VALVES

SIZE (IN.)	CONNECTION	SERIES NO.
1/2"	Solder inlets x Solder outlet	34BLF313S
	FNPT inlets x FNPT outlet	34BLF313T
	CPVC inlets x CPVC outlet	34BLF313C
	PEX A inlets x PEX A outlet	34BLF313X2
	PEX B/C inlets x PEX B/C outlet	34BLF313X
	Solder inlets x CPVC outlet	34BLF313SC
	FNPT inlets x CPVC outlet	34BLF313TC
	PEX B/C inlets x CPVC outlet	34BLF313XC
	CPVC inlets x PEX B/C outlet	34BLF313CX
	PRESS inlets x PRESS outlet	34BLF313PR
	PUSH inlets x PUSH outlet	34BLF313P

SIZE (IN.)	CONNECTION	SERIES NO.
3/4"	Solder inlets x Solder outlet	34BLF314S
	FNPT inlets x FNPT outlet	34BLF314T
	CPVC inlets x CPVC outlet	34BLF314C
	PEX A inlets x PEX A outlet	34BLF314X2
	PEX B/C inlets x PEX B/C outlet	34BLF314X
	Solder inlets x CPVC outlet	34BLF314SC
	FNPT inlets x CPVC outlet	34BLF314TC
	PEX B/C inlets x CPVC outlet	34BLF314XC
	CPVC inlets x PEX B/C outlet	34BLF314CX
	PRESS inlets x PRESS outlet	34BLF314PR
	PUSH inlets x PUSH outlet	34BLF314P

SIZE (IN.)	CONNECTION	SERIES NO.
1"	Solder inlets x Solder outlet	34BLF315S
	FNPT inlets x FNPT outlet	34BLF315T
	PEX A inlets x PEX A outlets	34BLF315X2
	PEX B/C inlets x PEX B/C outlets	34BLF315X
	PRESS inlets x PRESS outlet	34BLF315PR
	PUSH inlets x PUSH outlet	34BLF315P

* PEX A (ASTM F1960) Cold Expansion PEX
 ** PEX B/C (ASTM F1807) Crimp PEX



MVB-LF (34BLF SERIES)

POINT OF USE THERMOSTATIC MIXING VALVE

DIMENSIONS

SERIES NO.	CONNECTION	SIZE (IN.)	DIMENSIONS (IN.)						WEIGHT (LB.)
			A	B	C	D	E	F	
34BLF313T	Thread - FNPT	1/2	5.04	2.85	3.05	6.09	1.87	0.95	2.70
34BLF313S	Solder		5.12	2.93	3.13	6.25	1.87	0.93	2.54
34BLF313C	CPVC		4.89	2.70	2.90	5.79	1.87	0.70	2.42
34BLF313X2	PEX A		5.14	4.24	4.44	8.87	1.87	1.20	2.60
34BLF313X	PEX B/C		5.14	2.95	3.15	6.29	1.87	1.02	2.60
34BLF313PR	Press		5.19	2.99	3.19	6.37	1.87	0.99	2.65
34BLF313P	Push		6.43	4.24	4.44	8.87	1.87	1.23	3.45
34BLF314T	Thread - FNPT	3/4	5.12	2.93	3.13	6.25	1.87	0.93	2.80
34BLF314S	Solder		5.12	2.93	3.13	6.25	1.87	0.93	2.60
34BLF314C	CPVC		5.18	2.99	3.18	6.37	1.87	0.92	2.40
34BLF314X2	PEX A		6.43	4.24	4.44	6.37	1.87	1.20	2.60
34BLF314X	PEX B/C		5.14	2.95	3.15	6.29	1.87	1.25	2.60
34BLF314PR	Press		5.33	3.13	3.33	6.65	1.87	1.14	2.70
34BLF314P	Push		5.95	3.76	4.44	8.87	1.87	1.78	3.20
34BLF315T	Thread - FNPT	1	5.25	3.02	3.22	6.43	2.12	1.06	3.58
34BLF315S	Solder		5.25	3.02	3.22	6.43	2.12	1.06	3.34
34BLF315C	CPVC		5.38	3.15	3.35	6.69	2.12	1.16	3.31
34BLF315X2	PEX A		5.75	3.55	3.75	7.48	2.12	1.17	3.70
34BLF315X	PEX B/C		5.36	3.13	3.33	6.65	2.12	1.55	3.39
34BLF315PR	Press		5.37	3.14	3.37	6.74	2.12	1.18	3.31
34BLF315P	Push		6.05	3.85	4.05	8.09	2.12	1.96	4.50

* PEX A (ASTM F1960) Cold Expansion PEX
 ** PEX B/C (ASTM F1807) Crimp PEX

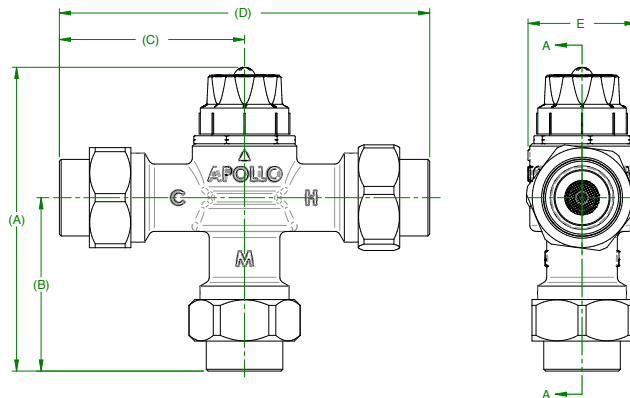

TAILPIECES

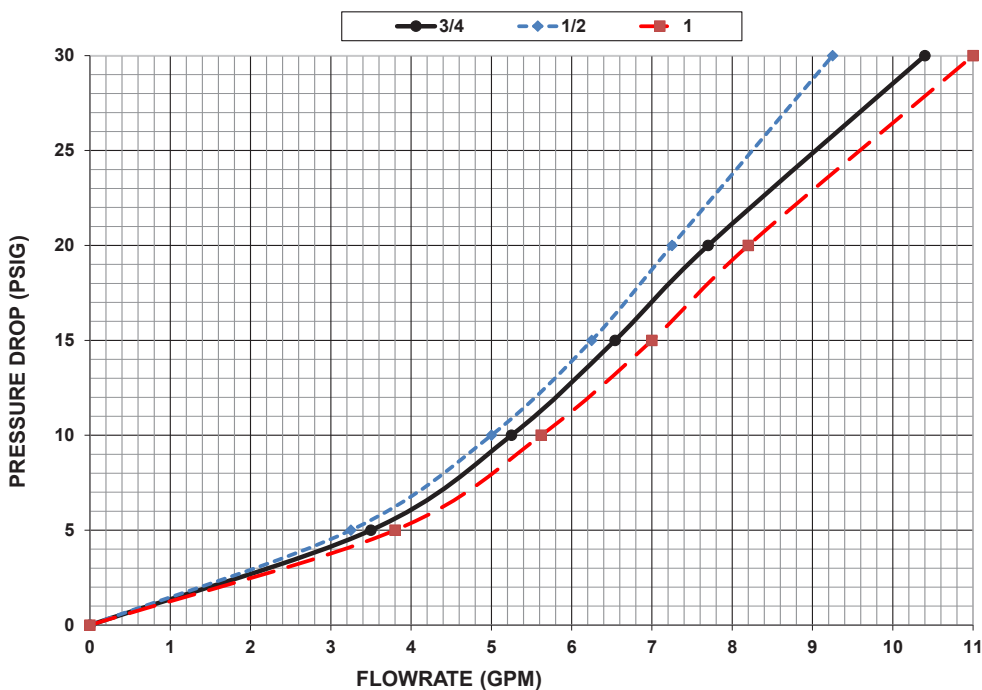
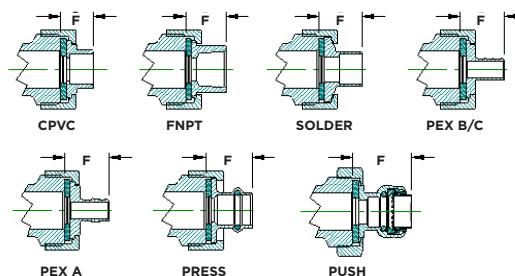



MVC (34C/34CLF SERIES)

HIGH CAPACITY THERMOSTATIC MIXING VALVE



3/4" - 1"

STANDARD MATERIAL LIST

BODY	C89836 Lead Free Bronze
SHUTTLE	Glass Filled Noryl [®]
SENSOR	Copper/Wax Filled
STEM	ASTM B16 C3600 Brass
SPRING	Stainless Steel
RETAINER	ASTM B16 C3600 Brass

Apollo® Model MVC-LF (34C-LF Series) ASSE 1017 listed, High-Capacity Mixing Valves are thermostatically controlled regulating valves designed for use in large commercial and institutional "point of source" and hydronic hot water systems or applications. Simple adjustment of water temperature from 90°-140°F or 130°-180°F.

SPECIAL FEATURES

Apollo® 34CLF mixing valves feature a two-piece shuttle with integral over-travel spring so they're smaller and easier to install than other high-capacity valves. Plus, their patented snap-fit element retainer and shuttle with special finger-grip pads assure easy removal and servicing without the need for special tools.

FEATURES

- Standard Temperature Range 90°-140°F (-01 suffix)
- High Temperature Range 130°-180°F (use suffix "H1") for Hydronic/Radiant Heating Systems
- Highest Flow Rates in its Class, Up to 165 gpm
- Threaded Connections
- All-Bronze and Stainless Steel Construction
- Patented Design for Easy In-Line Maintenance
- Supply Pressures to 150 psig
- U.S. Patent #6,328,219
- Lead Free Construction Certified: 0.25% Lead Max
- **Made in USA - ARRA Compliant**

OPTIONS

- (-01) Standard Temp 90° - 140°F
- (-H1) Hydronic High Temps/Non-ASSE 130° - 180°F
- Bronze Wye Strainer - See 59LF Series
- 34C Standard Bronze Construction for Radiant Applications

APPROVALS

- ASSE 1017 - Temperature Actuated Mixing Valve for Hot Water Distribution Systems
- CSA B125.3 - Plumbing Supply Fittings
- NSF/ANSI 372 - Lead Free

SIZE (IN.)	CONNECTION	STANDARD TEMP (90° - 140°F)		HIGH TEMP (130° - 180°F)*	
		MODEL NO.	ORDER NO.	MODEL NO.	ORDER NO.
3/4"	FNPT Inlets x FNPT Outlet	MVC34	34C10401	MVCH34	34C104H1
		MVC34LF	34CLF10401	MVCH34LF	34CLF104H1
1"	FNPT Inlets x FNPT Outlet	MVC1	34C10501	MVCH1	34C105H1
		MVC1LF	34CLF10501	MVCLFH1	34CLF105H1

*High temperature models are not ASSE certified.

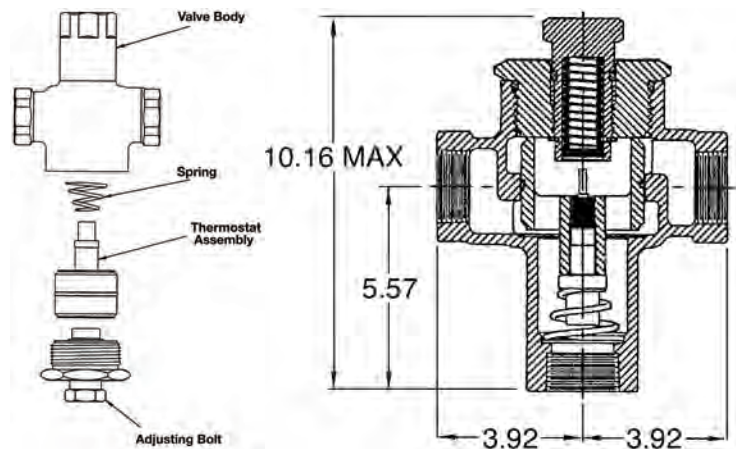



MVC (34C/34CLF SERIES)
HIGH CAPACITY THERMOSTATIC MIXING VALVE



1-1/4" - 2"

PERFORMANCE RATING

- Minimum Flow Rate: 1.0 gpm*
- Maximum Pressure: 150 psig
- Minimum Temperature: 200°F
- Cold Water Inlet Temperature Range: 39° - 80°F
- Hot Water Inlet Temperature Range: 120° - 200°F
- Mixed Water Temperature Range: 90° - 140°F
- Maximum Pressure Differential Between Hot & Cold: 25%

**when installed at/near hot water source w/ recirculated tempered water with a continuously operating pump*

SIZE (IN.)	CONNECTION	STANDARD TEMP (90° - 140°F)		HIGH TEMP (130° - 180°F)*	
		MODEL NO.	ORDER NO.	MODEL	SERIES
1-1/4"	FNPT inlets x FNPT outlet	MVC114	34C10601	MVCH114	34C106H1
		MVC114LF	34CLF10601	MVCH114LF	34CLF106H1
MVC112		34C10701	MVCH112	34C107H1	
MVC112LF		34CLF10701	MVCH112LF	34CLF107H1	
2"	MVC2	34C10801	MVCH2	34C108H1	
	MVC2LF	34CLF10801	MVCH2LF	34CLF108H1	

**High temperature models are not ASSE certified.*

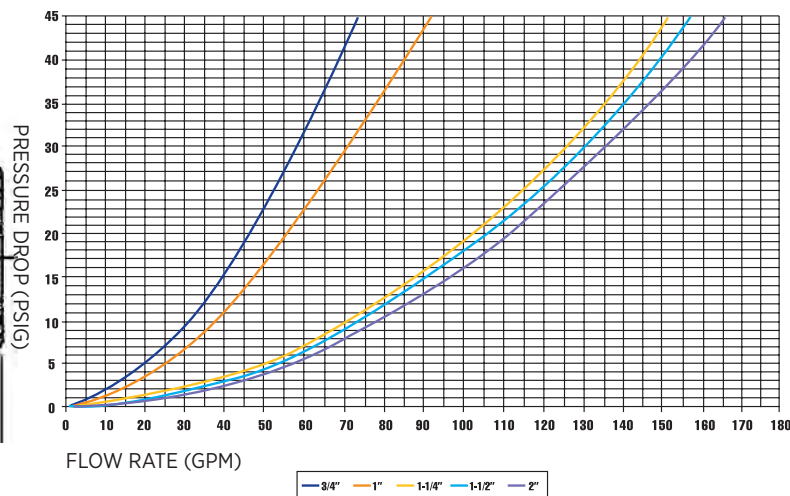
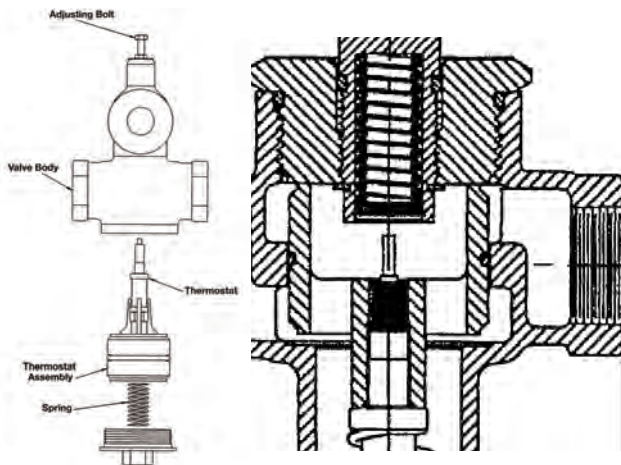

MIXING VALVES



MVD (34DLF SERIES)

SINGLE FIXTURE THERMOSTATIC MIXING VALVE



Apollo® MVD (34DLF Series) Mini Thermostatic Mixing Valves are designed for ASSE 1070 "Point of Use" temperature control applications with a single fixture using proven ASTM grade materials. These valves will hold a desired temperature within $\pm 3^{\circ}\text{F}$ and will shut off flow in the event of hot or cold water failure. They come equipped with a tamper-resistant cap and high temperature limit stop to prevent adjustment above 120°F .

FEATURES

- Tamper Resistant Locking Control Knob
- Adjustable Maximum Temperature Limit Stop
- Crush Proof Integral Check Valves
- Hot/Cold Water Failure Protection
- Single Outlet Model for Sensor Faucets
- Bypass Fitting Option for Dual Fixture Faucets
- Satin Chrome Plating Option
- 3/8" Compression or Hose Connections
- Mounting Bracket Included
- Lead Free Construction Certified: 0.25% Lead Max
- Made in the USA - ARRA Compliant

APPROVALS

- ASSE 1070 - Performance Requirements for Water Temperature Limiting Devices
- CSA B125.3 - Plumbing Fittings
- NSF/ANSI 372 - Lead Free
- NSF/ANSI 61 - Water Quality

STANDARD MATERIAL LIST

BODY	C89836 Lead Free Bronze
SHUTTLE	Modified PPO Noryl®
O-RING	Chloramine Resistant EPDM
SENSOR	Copper/Wax Filled
SPRING	ASTM A313 Stainless Steel
CAP	ABS Thermoplastic

SIZE (IIN.)	MODEL NO.	ORDER NO.	CONNECTION	FINISH	DESCRIPTION	WEIGHT (LB.)
3/8	MVD-LF	34DLF30201	Compression Inlet x Compression Outlet	Bronze	3/8" Single Inlet	0.82
3/8	MVDR-LF	34DLF30217		Chrome Plated	3/8" Single Inlet	0.82
3/8	MVDB-LF	34DLF302B1		Bronze	3/8" Double Inlet (bypass)	1.00
3/8	MVDBR-LF	34DLF302B17		Chrome Plated	3/8" Double Inlet (bypass)	1.00

PERFORMANCE RATING

- Minimum Supply Pressure: 30 psi (207 kpa)
- Minimum Inlet/Outlet Temperature Differential: 15°F
- Maximum Hot/Cold Pressure Differential: 25%
- Hot Inlet Temperature Range: 120° - 200°F (49° - 93°C)
- Cold Inlet Temperature Range: 38° - 80°F (3.3° - 27°C)
- Outlet Temperature Control: 80° - 120°F (27° - 49°C)
- Mixed Water Temperature Range: 80° - 120°F (27° - 49°C)
- Mixed Water Temperature Tolerance: $\pm 7^{\circ}\text{F}$
- Maximum Pressure: 150 psi (10.3 bar)
- Flow Rate: 0.5* - 3.2 gpm

*must use recirculation pump loop for <1.0 gpm flow

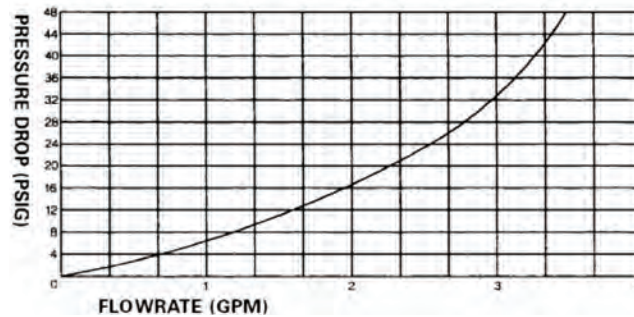
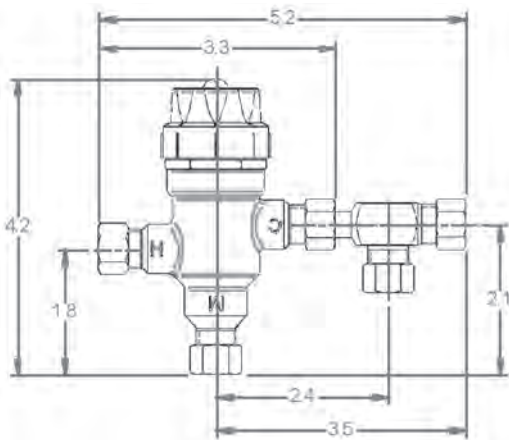



TV (34-200 SERIES)
HYDRONIC MIXING VALVE



The Apollo® Model TV (34-200 Series) Thermostatic Mixing Valve provides non-ASSE extension of water heater capacity and hot water temperature control in hydronic heating systems. Available in low or high temperature options for floor or baseboard applications.

FEATURES

- Stainless Steel Spring
 - Corrosion Resistant Bronze Body
 - Thermoplastic Shuttle Assembly
 - Solder Connections are Standard
 - In-Line Repairable
 - Fingertip Temperature Control
 - **Made in USA - ARRA compliant**
- *Not intended for potable water

DIMENSIONS

ORDER NO. LOW TEMP 85° - 120° F	ORDER NO. HIGH TEMP 120° - 180° F	CONNECTION	SIZE (IN.)	DIMENSIONS (IN.)		WEIGHT (LB.)
				HEIGHT	WIDTH	
34203L1	3420301	Solder	1/2	4.45	3.75	1.4
34204L1	3420401	Solder	3/4	4.47	4.00	1.46

STANDARD MATERIAL LIST

BODY	C83600 Bronze
SHUTTLE	Scale Resistant Noryl® Polymer
SENSOR	Copper/Wax Filled
O-RING	Chloramine Resistant EPDM
SPRING	ASTM A313 Stainless Steel
CAP	ABS Thermoplastic

PERFORMANCE RATING

- Maximum Supply Pressure: 150 psi (1034 kpa)
- Minimum Inlet/Outlet Temperature Differential: 15°F
- Hot Inlet Temperature Range: 120° - 210°F (49° - 99°C)
- Cold inlet temperature Range: 39° - 80°F (4° - 27°C)
- Outlet Temperature Control: 80° - 120°F (27° - 49°C)
- Outlet Temperature Control (Hydronic): 120° - 180°F
- Low Temperature (L1) Mix Range: 85° - 120°F (30° - 49°C)
- High Temperature (O1) Mix Range: 120° - 180°F (49° - 82°C)
- Mixed Water Temperature Tolerance: +/- 7°F (1.7°C)

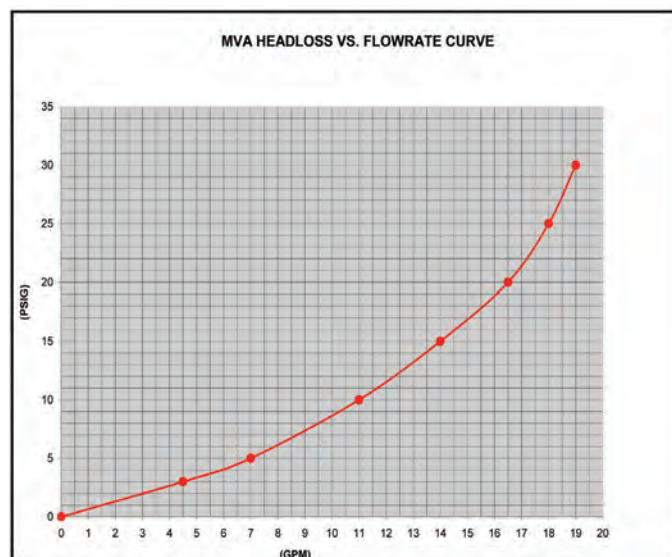
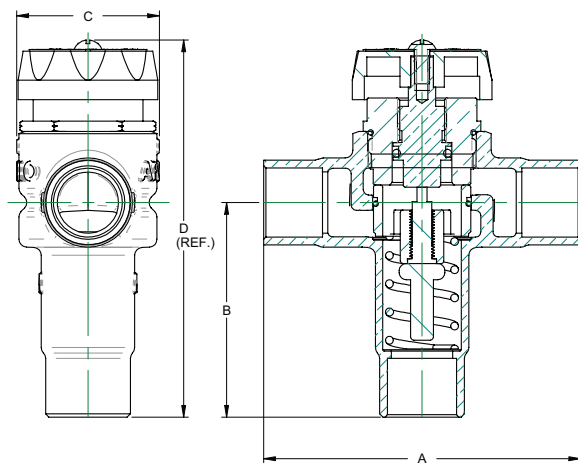

MIXING VALVES



34HL SERIES US PATENT #6,929,188 B2
HIGH-LOW MIXING VALVE



1017
1069



The 34HL Mixing Valve uses proven Apollo® thermostatic control to produce a consistent mix of water from low through high flow range. This single assembly controls mixed water temperatures to multiple-outlet shower and sink installations. It's the ideal choice in new construction or retrofits in nursing homes, prisons, hospitals, schools, gymnasiums, airports and other facilities where constant safe water temperature needs to be maintained at several outlets without the use of independent ASSE 1016 shower valves.

Standard bronze construction. Not intended for potable water applications.

FEATURES

- Capable of maintaining safe, consistent temperature control of water at low and high flows to within $\pm 3.6^\circ\text{F}$.
- Provides consistent temperature control at flow rates as high as 60 GPM and as low as 1.5 GPM, including mid-range flow between high and low.
- Does not require recirculation pumps like other systems for low flow control.
- Integral strainers and checks are provided at the hot and cold supply inlets for greater reliability and performance.
- **Made in USA - ARRA compliant.**

OPERATION

- Patented design with a variable fluid flow assembly and dual thermal actuated controls for either low or high flow conditions.
- The passages are calibrated to control water temperature during all flow conditions without a "dead zone" between low and high flow.
- Provides fluid shutoff as required by ASSE 1069 in the case that either the hot or cold supply lines fail (or are shut off for any reason to prevent scalding).
- The valve can be tamper-resistant to limit the water temperature from exceeding safe conditions as required by ASSE 1069.
- The valve also meets the requirements of ASSE 1017 for Point of Source Applications.

STANDARD APPROVALS

ASSE 1069 - Automatic Temperature Control Mixing Valves

- This device will control outlet water temperature to individual or multiple fixtures within 3.6°F to reduce the risk of scalding or thermal shock. This device is intended to be installed where the bather has no access to the temperature adjustment, and where no further mixing occurs downstream of the device. The Apollo® 34HL ATC will meet the performance requirements of ASSE 1069 at flow as low as 1.5 GPM up through maximum flow rate.

ASSE 1017 - Temperature Actuated Mixing Valves for Hot Water Distribution Systems

- This device will control outlet set water temperature to hot water distribution systems near the hot water source within 3°F below 2 GPM and within 5°F above 5 GPM.

OPTIONS

- 34HL10517 Nickel Plated Automatic Temperature Controller
- 34HLBOX01 Cabinet, Flush Mount, SS
- 34HLBOX02 Cabinet, Flush Mount, CS, Powder Coat
- 34HLBOX03 Cabinet, Wall Mount, SS
- 34HLBOX04 Cabinet, Wall Mount, CS, Powder Coat

SPECIFICATIONS

MAXIMUM STATIC PRESSURE	150 psig (1034 kpa)
MAXIMUM WATER TEMPERATURE	200° F (93° C)
MINIMUM FLOW ASSE 1069 & 1017	1.5 gpm (5.7 lpm)
TEMPERATURE ADJUSTMENT RANGE	90° - 140° F
MAXIMUM INLET PRESSURE DIFFERENTIAL	30 psi (207kpa)
INLET CONNECTION	1" NPT
OUTLET CONNECTION	1-1/4" NPT
TEMPERATURE GAUGE (1)	0-200°F
PRESSURE GAUGE (3)	0-160 psi
SHIPPING WEIGHT	36 lb

This device will service end use fixture fittings, including but not limited to, gang showers and sitz baths, by supplying tempered water at a preset temperature through a single supply pipe and will meet ASSE standard 1069-2005. ASSE 1069 devices are designed to reduce the risk of scalding and thermal shock during changes in hot or cold water supply pressure or temperature, or loss of cold water supply.



34HL SERIES
HIGH-LOW MIXING VALVE

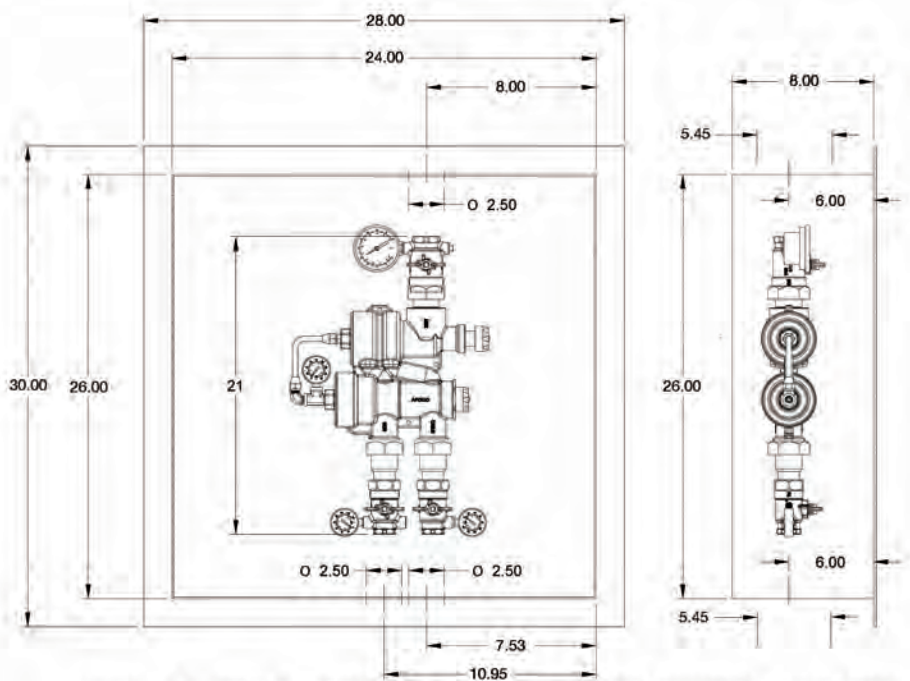

Figure 1: Typical Valve Dimensions with Stainless Steel Recessed Cabinet Option

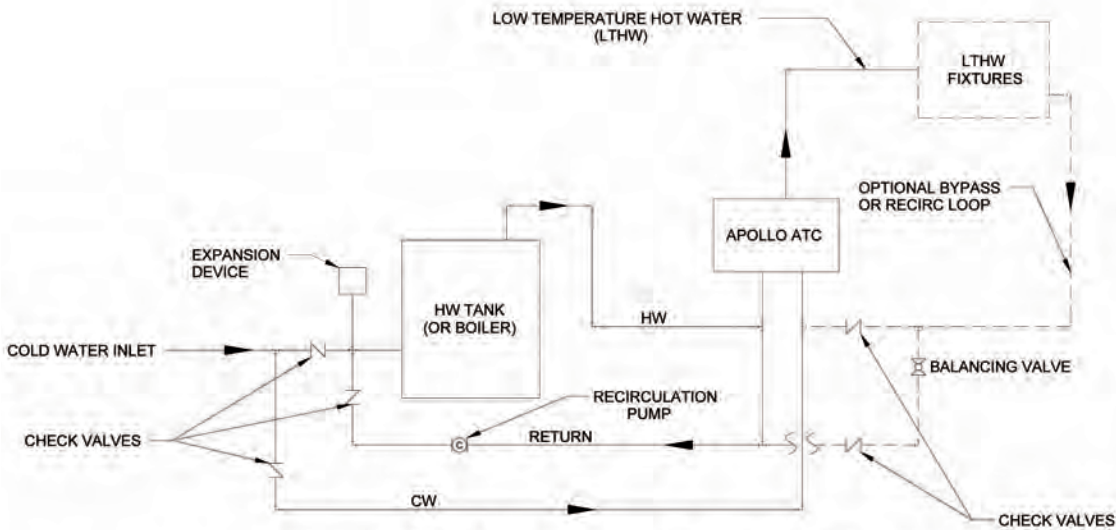

Figure 2: Typical Installation with Optional Recirculation loop

ORDER NO.	MIN. FLOW TO ASSE 1069	PRESSURE DROP ACROSS VALVE			
		10 PSI (69 KPA)	20 PSI (138 KPA)	30 PSI (207 KPA)	45 PSI (310 KPA)
34HL10501	1.5 gpm	22 gpm	42 gpm	52 gpm	60 gpm
	6 lpm	83 lpm	159 lpm	197 lpm	227 lpm



MVE (34E/34ELF SERIES)
EMERGENCY EYE WASH MIXING VALVE



Apollo® Model "MVE" (34E Series) Emergency Mixing Valves are designed to control the cold and hot water temperature to deliver tepid water at a predetermined temperature to emergency eyewash/facewash fixtures. The device provides a precise temperature and flow control in the event of cold water, hot water and thermostatic element failures.

FEATURES

- Hot And Cold Water Supply Failure Protection Patented Design (US Patent 6,926,20 B2)
- Tepid Water Temperature Limit Control and Adjustment
- Tepid Water Temperature Adjustment Handle with Locking Mechanism for Tamper-Resistant Protection and Inadvertent Adjustment
- Integral Inlet Check Valves and Strainers to Provide Protection Against Cross-Flow and Foreign Particles
- Superior Thermostatic Element Technology for Optimum Reliability, Dependability and Accuracy
- Thermostatic Element Failure and Over-Travel Protection
- High Efficiency and Positive Shut-Off Check Valves
- In-Line Accessibility and Serviceability of Failure Protection Module and Mixing Valve Internal Components
- Meets the Requirements of the EPA Safe Drinking Water Act
- Corrosion Resistant Components
- Single Cartridge Design of Failure Protection Module for Easy Service and Maintenance
- Integral Hot Water Bypass
- Positive Shutoff of Hot Supply When Cold Supply is Lost
- Lead Free Construction Certified: 0.25% Lead Max - Specify Model 34ELF
- **Made in USA - ARRA compliant**

APPROVALS

- ASSE 1071 - Temperature Actuated Mixing Valves for Plumbed Emergency Equipment
- ANSI/ISEA Z358.1 2009 Emergency Eyewash & Shower Equipment
- NSF/ANSI 372 - Lead Free (34ELF)
- NSF/ANSI 61 - Water Quality (34ELF)

PERFORMANCE RATING

- Maximum Working Pressure: 150 psig (1034 kPa)
- Hot Water inlet Temperature Range: 120° - 180°F (49° - 82°C)
- Cold Water inlet Temperature Range: 40° - 70°F (4.4° - 21°C)
- Tepid Water Temperature Adjustment Range: 65° - 95°F (18.3° - 35°C)
- Mixed Water Temperature Tolerance: ± 5°F (2.8°C)
- Flow Rate @ 30 psig (206.9 kPa) Differential: 15 gpm (56.8 lpm)
- Cold Bypass @ 30 psi (207 kPa) Differential: 13.5 gpm (51 lpm)

Note: The cold water supply shall be at least 20°F (-6.7°C) lower than the outlet water temperature setting

TYPICAL INSTALLATIONS

- Piping and installation of the device must be in accordance to federal, state, and local plumbing codes.
- If the valve is some distance from the hot water source, recirculation is required to keep the hot water supply temperature within the required operational limits.

OPTIONS

- 34ELF - Lead Free

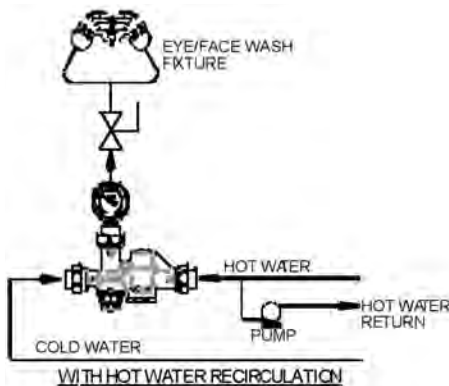
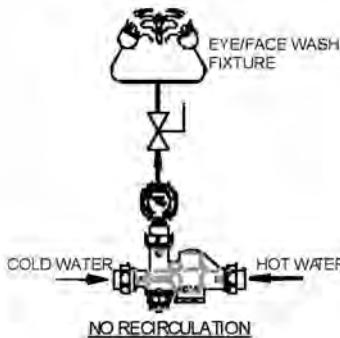



MVE (34E SERIES)
EMERGENCY EYE WASH MIXING VALVE

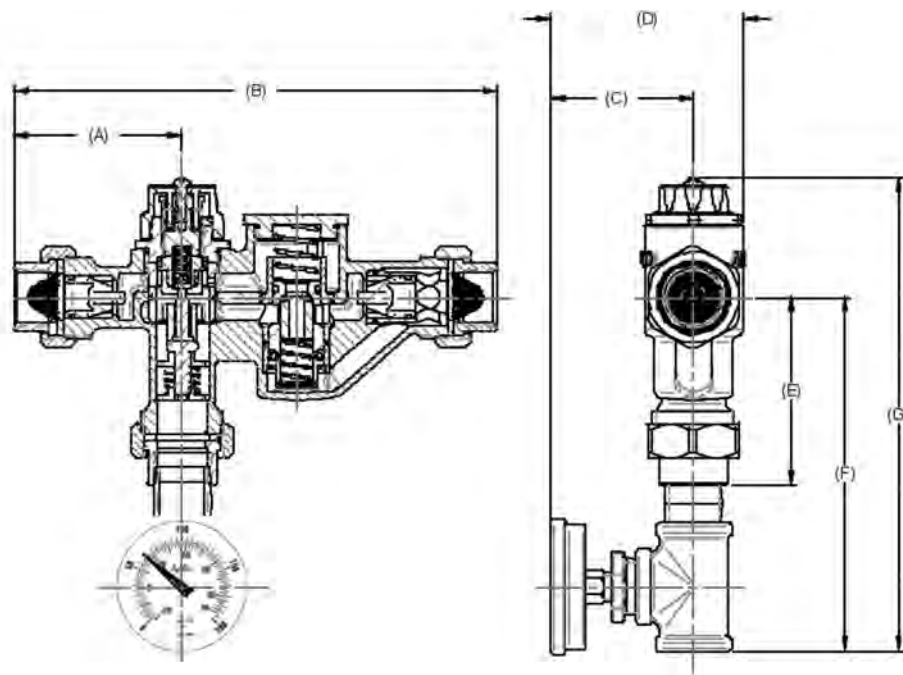

CONNECTION SIZE		1/2" THREADED	1/2" SOLDER	3/4" THREADED	3/4" SOLDER
Basic Valve	Model No.	MVEI2	MVESI2	MVE34	MVES34
	Ordering No.	34E103T	34E103S	34E104T	34E104S
Includes Outlet Temperature Gauge	Model No.	MVEI2G	MVESI2G	MVE34G	MVES34G
	Ordering No.	34E113T	34E113S	34E114T	34E114S
Includes Outlet Temp. Gauge And Inlet Ball Valves	Model No.	MVEI2GB	MVESI2GB	MVE34GB	MVES34GB
	Ordering No.	34E123T	34E123S	34E124T	34E124S
Lead Free Basic Valve	Model No.	MVEI2LF	MVESI2LF	MVE34LF	MVES34LF
	Ordering No.	34ELF103T	34ELF103S	34ELF104T	34ELF104S
DIMENSIONS (IN.) & WEIGHT (LB.)					
	A	3.09	3.22	3.09	3.10
	B	8.90	9.15	8.90	8.90
	C	2.66	2.66	2.67	2.67
	D	3.60	3.60	3.60	3.60
	E	3.45	3.45	3.45	3.45
	F	5.77	5.77	6.32	6.32
	G	7.83	7.83	8.39	8.39
	Unit Wt.	3.94	3.73	5.13	5.07

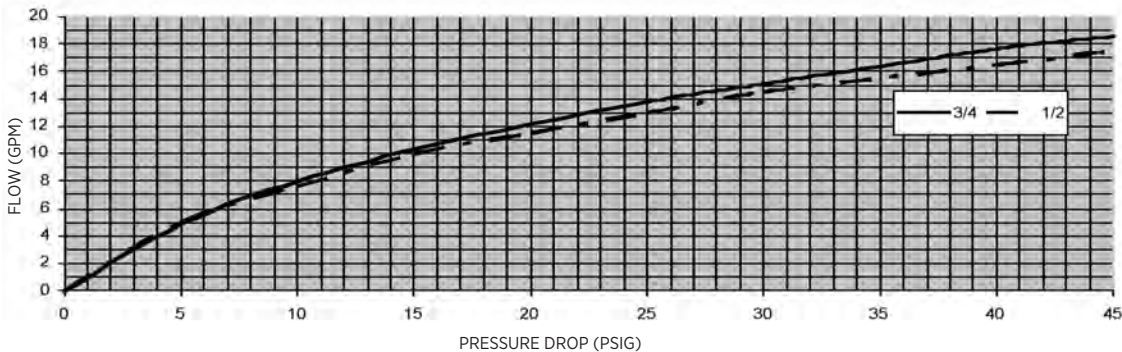

MIXING VALVES



TEMPERATURE GAUGE



The Apollo® Temperature Gauge accessory is used to easily measure the mixed water temperature from a mixing valve. The gauge can be used on the Apollo® 34ALF & 34BLF Series Mixing Valves sizes 1/2" & 3/4", is lead free and complies with NSF/ANSI 372 requirements.

PERFORMANCE RATING

- Maximum Working Pressure: 150 psig
- Gauge Temperature Range: 32° - 210°F

PART NUMBERS

PART NUMBER	SIZE
W339800	1/2"
W339900	3/4"

STANDARD MATERIAL LIST

BODY	DZR Brass
GAUGE SHELL	Stainless Steel
NUT	DZR Brass
WASHER	EPDM

TANKMAX THERMAL MIXING VALVE



The Apollo® Tank Max Thermal Mixing Valve mixes hot water with cold to deliver 120°F water to fixtures. By setting the heater to 140°F or higher and mixing with cold water to deliver 120°F, the effective volume of 120°F delivered increases significantly. Tank Max is factory set at 120°F outlet temperature, but is easily adjustable to the needs of the system.

COMPONENTS

- 1 - Thermostatic Mixing Valve
- 1 - Tee Fitting
- 1 - Union Fitting
- 1 - 18" Flex Hose
- 1 - Water Temperature Gauge

PERFORMANCE RATING

- Operating Temp. Range: 90°-130°F
- Factory Set Temp. Range: 115°-120°F
- Hot Temp. Supply Range: Max 195°F
- Cold Temp. Supply Range: 39°-80°F
- Maximum Supply Pressure: 150 PSI
- Minimum Flow Rate: 1 GPM
- Maximum Flow Rate: See SS1454

CONNECTIONS

- 3/4" MNPT Mixing Outlet x 3/4" FNPT Union Fitting x 3/4" NPSH Cold Inlet

STANDARD MATERIALS LIST

BODY	Bronze
SEALS	EPDM
SPRINGS	Stainless Steel
INTERNAL CAP	Brass
PISTON	Engineered Polymer
GUIDE TUBE	Noryl GFN2

APPROVALS

- ASSE 1017
- NSF/ANSI 61 - Water Quality
- NSF/ANSI 372 - Lead Free
- IAPMO Listed
- CSA B125.3

"Apollo"®

36 - 36LF	H-5
36C - 36CLF	H-8
36E - 36ELF (1/2"-1")	H-10
36ELF-G	H-11
36E - 36ELF (1-1/4"-2")	H-14
36H -36HLF	H-16
A127	H-19
ACCESSORIES	H-20
TPK	H-13

WATER PRESSURE REDUCING VALVES

WHY THE NEED FOR WATER PRESSURE REDUCING VALVES?

Municipal water is distributed at elevated pressures for efficiency, and supply pressures can exceed 150 psi. The greater the elevation changes in a region, the higher the supply pressures. Booster pump systems in high-rise buildings can even exceed 250 psi. Water pressure reducing valves are designed to automatically reduce such elevated supply pressures to a lower, safer and more manageable downstream pressure. In most plumbing code jurisdictions, pressure reducing valves are required to be installed whenever the water pressure supply exceeds 80 PSI. Excessive pressures can waste tens of thousands of gallons of water in an average home every year.

THE VALUE OF ECONOMIZING

Installing a water pressure regulator offers many benefits:

- Reduces water consumption.

- Reduces associated energy and utility costs.

- Protects piping systems and fixtures from excessive pressures that can reduce service life, cause water hammer, and other undesirable piping noises.

- Used to ensure compliance with local plumbing codes.

The use of a water pressure reducing valve also helps to protect the environment and conserves our precious natural resources.

OPERATION

Apollo® cast bronze water pressure reducing valves are “direct acting” devices, meaning no external pilots or sensing lines are required. Direct acting valves are “normally open”, meaning the internal seat is held open by the force of a compression spring. As water flows through the valve and the downstream pressure begins to build, this pressure acts on the relatively larger surface area of the diaphragm. As the downstream pressure continues to increase, eventually the force acting on the diaphragm overcomes the force of the spring and the valve seat is hydraulically closed. This is the static (non-flowing) set pressure and is factory preset at 50 to 60 psi, depending upon the model.

When downstream demand begins (such as a faucet being opened), the line pressure will drop and the force of the spring begins opening the valve seat. This allows higher pressure water to flow into the system until the static set pressure is once again reached and the valve seat closes. Apollo’s balanced piston design enables the valve to react smoothly and quickly to changing flow demands, while protecting against incoming supply pressure changes.

ADJUSTMENT

The static set pressure of the valve can be adjusted by changing the preload on the spring by means of the adjusting screw. After loosening the lock nut, turning the screw clockwise (down) will increase the set point, while turning it counter-clockwise (up) reduces the set point. Tighten the locknut after adjustment to secure the setting. The static set pressure can be adjusted through the published range of the installed spring (eg. 25 to 75, 75 to 150 etc.). Refer to the Installation, Operation & Installation Instructions (IOM) for additional detail.

Note when reducing the set pressure it may be necessary to briefly open and close a fixture to let the downstream pressure adjust to the new setting.

GAUGES

Dial pressure gauges may be used to measure the supply pressure and monitor/adjust the reduced pressure downstream of the valve. Some regulator models can be ordered with a 2” dial pressure gauge to display the reduced pressure (-G option); or select the “P” option which allows the installation of a gauge later. The “P” option adds a tapped and plugged, 1/4” NPT connection to the valve. Alternatively, a dial pressure gauge, with 3/4” hose thread (part no. W807800) can be connected to a hose bib or utility sink, to monitor pressure. This model features a 2-1/4” dial and maximum pressure indicator. Both types of gauges are available from your Apollo® distributor.

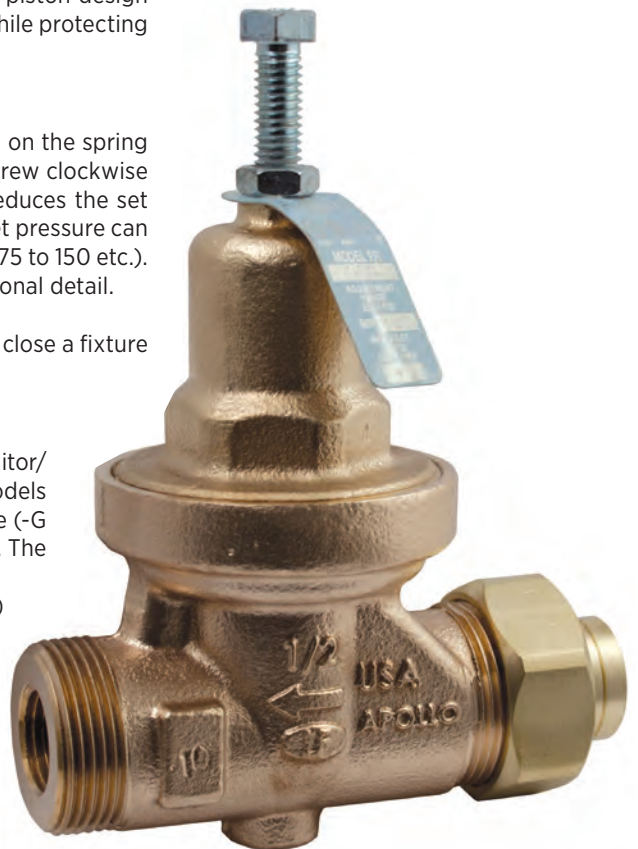

THERMAL EXPANSION CONSIDERATIONS

Installing a pressure reducing valve creates a closed water system, since the WPRV effectively acts as a check when the seat is closed. Thermal expansion occurs when water is heated in the water heater and pressure builds up. Apollo® water pressure reducing valves incorporate an internal thermal expansion bypass feature that will bleed the increased pressure back to the service main. When the system pressure in a closed system increases to a pressure greater than the supply pressure by just one pound, the o-ring on the stem will flex and allow the excess pressure to be relieved to the supply side until pressures on both the system and supply sides are equal. The valve and the system then return to normal. The 36HLF features a ball and seat type of check valve as a thermal bypass but the principle is similar.

SIZING & SELECTION

The size and model of pressure reducing valve you need depends on the flow rate / capacity required. It is therefore important to know the maximum supply pressure, desired static downstream pressure and required flow under normal demand conditions.

FLOW / PERFORMANCE CURVES

Apollo® publishes performance curves for all models of direct acting regulators. Flow curves plot the rate of flow against the reduced pressure fall-off based upon a specific differential pressure (see definitions below).

DIFFERENTIAL PRESSURE (DP)

Differential pressure is the difference in PSI between the supply pressure and the adjusted static (non-flowing) set pressure of the valve. Example 100 psi supply pressure – 50 psi static set pressure = 50 psi differential pressure.

REDUCED PRESSURE FALLOFF

“Falloff” is simply the difference in PSI between the static (non-flowing) set pressure of the valve and the reduced downstream pressure at a given flow rate. Falloff is inversely proportional to the flow: as flow increases and the seat opens wider the downstream pressure reduces (falls off). Falloff is a normal operating characteristic for all direct acting regulators.

It is important to allow for adequate fall-off from the set pressure downstream during flow conditions. 10 to 20 psi falloff is considered ideal for most applications. Less falloff means the valve is only partially open, and extreme throttling can cause noise, vibration and premature wear. Sizing at 10-20 psi falloff will allow the valve to operate nearer the middle of its operating range for optimal performance and durability.

In the chart, zero (0) falloff indicates a no-flow condition. Figures below zero show the flow curves for each size of valve as the fall-off pressures increase.

Example: A ¾” PRC with an inlet pressure of 100 psi is set to an outlet pressure of 50 psi in the static, no-flow condition (50 psi differential pressure). At 10 psi falloff the flow is 8 gpm, and at 20 psi falloff the flow is 21 gpm. This valve would be ideal for flows ranging from 8 to 21 gpm. Although this chart shows curves at a 50 psi Pressure Differential, curves for other DP’s are similar. The curve shifts slightly to the left for a smaller differential and to the right for a greater differential.

Do not select based solely on the maximum flow requirement!

Do not select a regulator based on pipe-size alone!

The two most common problems affecting water pressure reducing valves are: 1.) installing a larger valve than is needed for the volume of flow required. This is particularly true for valves larger than 1”, and 2.) Excessive one-step pressure reduction / Turndown Ratio . In either case the water pressure reducing valve will operate in a nearly closed position potentially causing premature wear and undesirable noise.

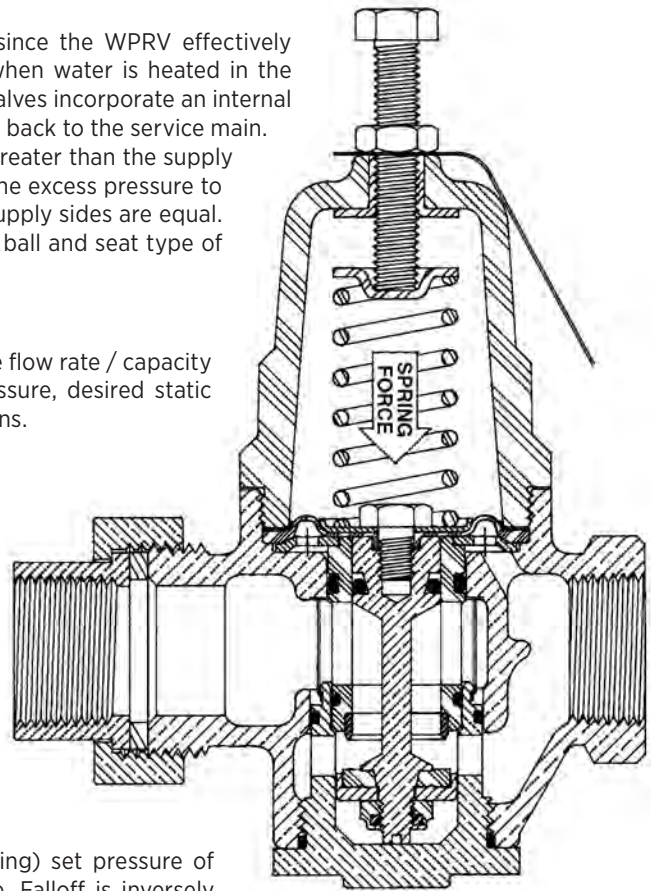

WATER PRESSURE REDUCING VALVES

TURNDOWN RATIO

Optimal performance is achieved at a 2:1 Differential Pressure ratio. Example: 100 psi supply pressure, 50 psi static downstream pressure = 2:1 reduction. 50 psi is the default factory setting. Turndown ratios of 3:1 are usually ok and even 4:1 can work but factors such as pressure, size, flow, velocity and falloff can result in noise or premature wear as the ratio increases.

TWO-STAGE REDUCTION

Two valves installed in series should be used for large pressure drop requirements. Example: valve #1 200 psi to 100 psi reduction, valve #2 100 psi to 50 psi reduction.

LOW FLOW BYPASS

When a large valve is called upon to provide small amounts of flow during off-peak hours, the valve seat is operating in a nearly closed position and undesirable noise and vibration may result. In this case a parallel low flow bypass line should be installed with a smaller regulator. The smaller regulator is set 5 - 7 psi higher than the main regulator and will help prevent premature wear and noise.

SPECIALLY DESIGNED LOW AND HIGH PRESSURE MODELS

Apollo® LP and HP models feature specially designed springs optimized for superior performance and flow. Beware competitors' that publish extreme pressure ranges such as 10 - 125 psi, as these valves lack sensitivity and tend to perform poorly, especially at the low and high ends of the pressure range.

REPAIR KITS AVAILABLE

Apollo® pressure reducing valves are engineered to provide years of reliable service. Over time, internals may be subject to wear or even damage caused by sand or debris. Convenient pre-packaged "major goods" repair kits are available for all Apollo® pressure reducing valves. A "soft-goods" only kit is also available for the 36CLF and 36HLF models.

INSTALLATION CONFIGURATIONS

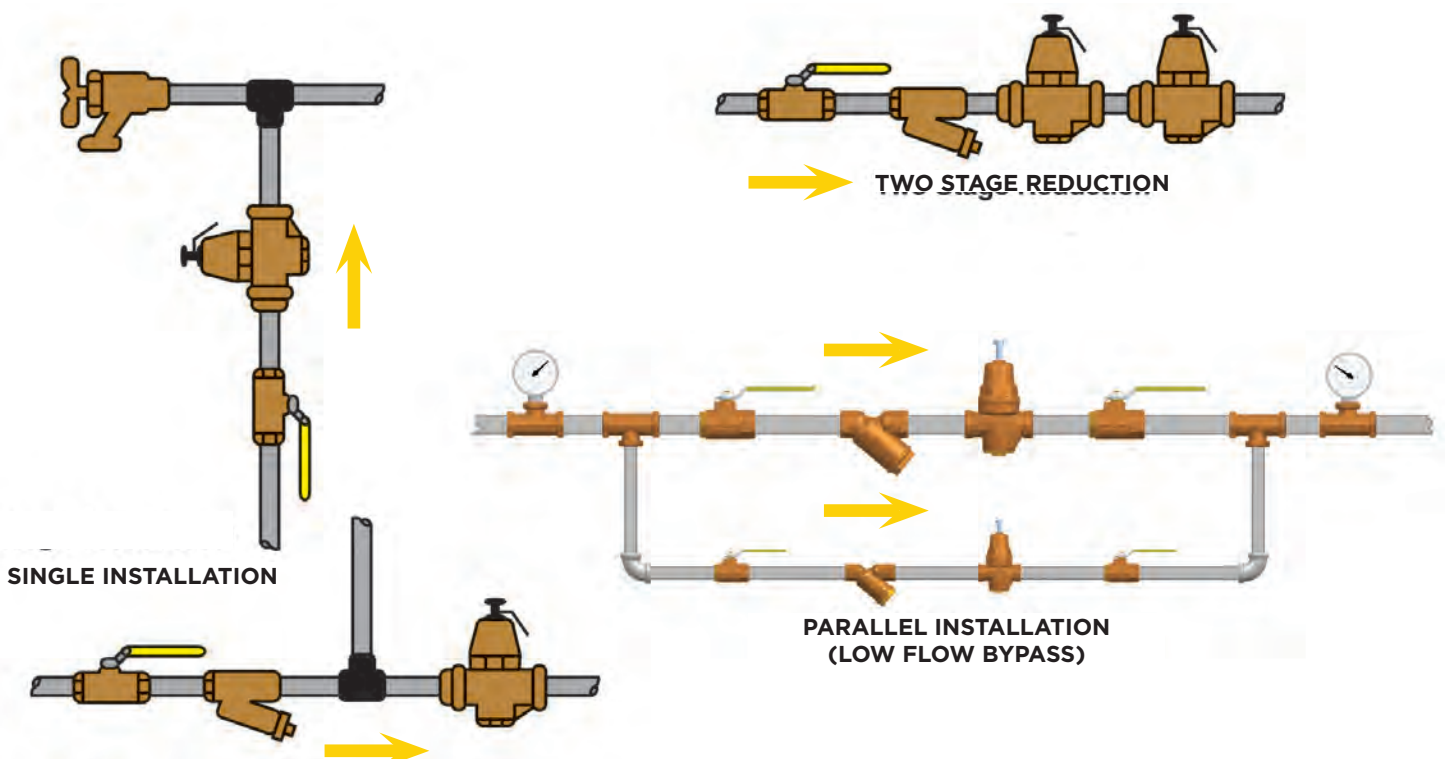

WATER PRESSURE REDUCING VALVES

PR SERIES (36LF)



Apollo® 36LF Series pressure reducing valves provide automatic control of excessive water pressure and problem supply fluctuations. These models are designed to reduce pressures of up to 300 PSI to a more manageable range.

Factory set at 50 PSI, they adjust with a turn of a screw. They feature a built-in bypass and strainer, and comply with ASSE 1003 and CSA B356 standards. They are listed with IAPMO and the City of Los Angeles.

The 36LF Series valves are built for long, reliable service with an all-bronze body and cover and high-capacity stainless steel strainer. Available with or without optional pressure gauge on tapping.

FEATURES

- All Bronze Body and Cover
- Suitable for Supply Pressures to 300 psi
- Every Valve is 100% Factory Set and Tested
- Standard Factory Setting: 50 psi
- High & Low Pressure Model Options
- Diaphragm Suitable for 33° - 180°F
- Solder, Threaded, PEX, CPVC, Press Connection Options
- Integral Thermal Expansion Bypass
- Integral Stainless Steel Strainer
- Single and Double Union Options
- In-Line Repairable
- USA Materials and Manufacture

OPTIONS

- (-P) Tapped & Plugged
- (-G) With Pressure Gauge
- (-S) Sealed Cage with SS Adjusting Screw for Vault Installation
- 36 Non-LF Materials for Non-Potable Service, Such as Irrigation

APPROVALS

- ASSE 1003
- CSA B356
- NSF/ANSI 372 Lead Free
- IAPMO

DIMENSIONS

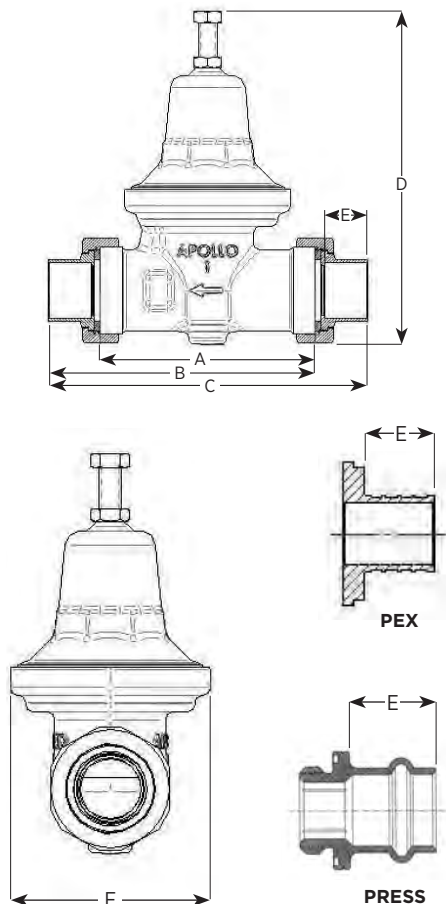

PIPE THREAD UNION X FNPT	SOLDER JOINT UNION X FNPT	CPVC UNION X FNPT	SIZE (IN.)	DIMENSIONS (IN.)			WT./100 (LB.)
				A	B	C	
36LF-103-01	36LF-303-01	-	1/2	5.88	4.88	1.00	350
36LF-104-01	36LF-304-01	36LF-3C4-01	3/4	5.88	4.88	1.00	340
36LF-105-01	36LF-305-01	36LF-3C5-01	1	6.88	5.50	1.12	450
36LF-106-01	36LF-306-01	-	1-1/4	8.88	6.50/6.63	1.37	1020
36LF-107-01	36LF-307-01	-	1-1/2	8.88	6.63/6.75	1.37	1045
36LF-108-01	36LF-308-01	-	2	11.50	8.50/8.88	1.81	2250
FNPT X FNPT (NO UNION)							
36LF-203-01	-	-	1/2	5.88	4.00	1.00	311
36LF-204-01	-	-	3/4	5.88	3.88	1.00	305
36LF-205-01	-	-	1	6.88	4.38	1.12	415
36LF-206-01	-	-	1-1/4	8.88	5.38	1.37	910
36LF-207-01	-	-	1-1/2	8.88	5.38	1.37	909
36LF-208-01	-	-	2	11.50	7.12	1.81	1880
DOUBLE UNION FNPT X FNPT	DOUBLE UNION SOLDER X SOLDER	DOUBLE UNION CPVC X CPVC	SIZE (IN.)	DIMENSIONS (IN.)			WT./100 (LB.)
36LF-403-01	36LF-503-01	-	1/2	5.88	5.63	1.00	389
36LF-404-01	36LF-504-01	36LF-5C4-01	3/4	5.88	5.63	1.00	372
36LF-405-01	36LF-505-01	-	1	6.88	6.38	1.12	495
36LF-406-01	36LF-506-01	-	1-1/4	8.88	7.50/7.75	1.37	1090
36LF-407-01	36LF-507-01	-	1-1/2	8.88	7.88/8.00	1.37	1183
36LF-408-01	36LF-508-01	-	2	11.50	9.88/10.50	1.81	2472
36LF-904-01	PEX x PEX	-	3/4	6.12	5.81	1.00	372
36LF-9C4-01	Union CPVC	PEX Union	3/4	6.12	5.81	1.00	372

*36 Series for non-potable water available.
Example: 36-103-01

WATER PRESSURE REDUCING VALVES

PR SERIES (36LF)

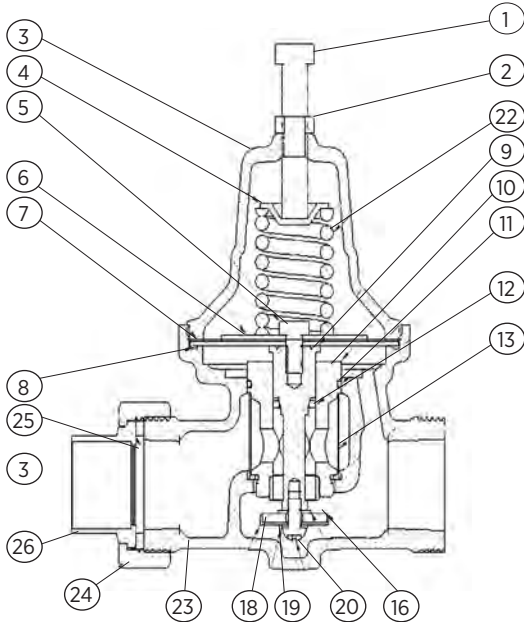

STANDARD MATERIALS LIST

1	Adj. Screw (Zinc Plated Steel)	14	Seal, Cartridge (Polypropylene)
2	Hex Nut (Zinc Plated Steel)	15	Seat Ring (300 Series SS)
3	Cap (Cast Bronze)	16	Washer (LF Brass)
4	Spring Disc (Zinc Plated Steel)	17	Seat Disc (FDA EPDM)
5	Cartridge Bolt	18	Seat Holder (LF Brass)
6	Pressure Plate (Zinc Plated Steel)	19	Washer (Polypropylene)
7	Friction Ring (Zinc Plated Steel)	20	Seat Screw (300 Series SS)
8	Diaphragm (FDA Nitrile)	21	Nameplate (Aluminum)
9	Stem (Brass)	22	Spring (ASTM 228 Music Wire)
10	Cartridge Housing (LF Brass)	23	Body, Machined (Cast LF Bronze)
11	O-Ring (FDA Nitrile)	24	Union Nut (Cast Bronze)
12	O-Ring (FDA Nitrile)	25	Union Washer (FDA Nitrile)
13	Screen (300 Series SS)	26	Union Tail Piece (LF Brass)

PART NUMBER MATRIX

36LF 36	X	X	X	X	X	X
SERIES	CONNECTION	OPTION	SIZE	GAUGE	PRESSURE RANGE	OPTION
36LF (LEAD FREE)	1 - SINGLE UNION NPT	0 - NO OPTION	3 - 1/2"	0 - NO GAUGE	1 - 25-75 PSIG	PR - PRESS
36	2 - NO UNION NPT	C - CPVC TAILPIECE	4 - 3/4"	P - W/ GAUGE PORT	2 - 10-35 PSIG	(APPLIES TO MODELS 36-20X
	3 - SINGLE UNION SOLDER X NPT	S - SEALED CAGE*	5 - 1"	G - W/ GAUGE	3 - 75-125 PSIG	AND 36LF20X ONLY)
	4 - DOUBLE UNION NPT	X - PEX F1807 TAILPIECE	6 - 1-1/4"			
	5 - DOUBLE UNION SOLDER		7 - 1-1/2"			
	6 - SINGLE UNION METER X NPT		8 - 2"			
	8 - DOUBLE UNION CPVC					
	9 - DOUBLE UNION PEX F1807					

* S option = Sealed cage with stainless steel adjusting screw for vault installation.

WATER PRESSURE
REDUCING VALVES

PR SERIES (36LF)

PIPE SIZE	*FALLOFF (PSI)	PRESSURE DIFFERENTIAL (PSI)		
		25	50	75
		WATER CAPACITY (GPM)		
1/2"	5	1.7	2.0	2.3
	10	4.3	5.0	5.8
	15	8.5	10.0	11.5
	20	15.3	18.0	20.7
3/4"	5	3.4	4.0	4.6
	10	7.7	9.0	10.4
	15	14.5	17.0	19.6
	20	22.1	26.0	29.9
1"	5	5.1	6.0	6.9
	10	11.9	14.0	16.1
	15	22.1	26.0	29.9
	20	34.0	40.0	46.0
1 1/4"	5	8.5	10.0	11.5
	10	19.6	23.0	26.5
	15	35.7	42.0	48.3
	20	52.7	62.0	71.3
1 1/2"	5	11.9	14.0	16.1
	10	27.2	32.0	36.8
	15	47.6	56.0	64.4
	20	68.0	80.0	92.0
2"	5	15.3	18.0	20.7
	10	39.1	46.0	52.9
	15	66.3	78.0	89.7
	20	93.5	110.0	126.5

*Falloff is the difference between the PRV's set pressure and the flowing pressure at any given demand

FLOW CURVE

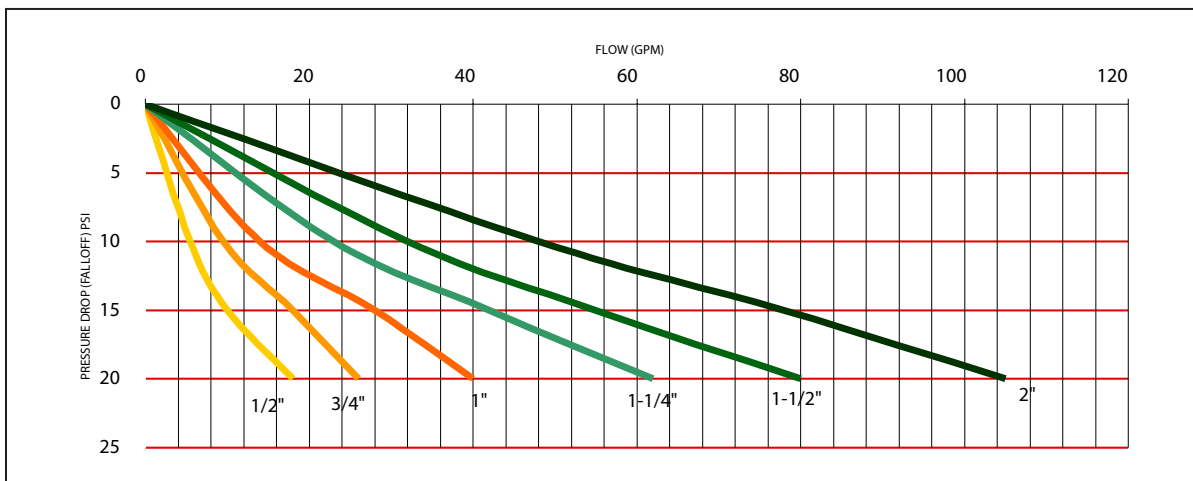

Pressure Differential is the difference between the inlet supply pressure and the adjusted outlet pressure.

Pressure Falloff is the reduction in downstream pressure from the static (set) pressure as the flow increases through the valve.

WATER PRESSURE
REDUCING VALVES

PRC SERIES (36CLF)



Versatile, all-purpose Apollo® 36CLF Series pressure reducing valves handle pressures up to 400 PSI. Compact and with a built-in thermal expansion by-pass, they're designed to protect residential and commercial water distribution systems from excessive pressures. The valves' integral thermoplastic cage helps protect the inner adjusting spring from galvanic corrosion. Built for reliable, long-term service, PRC valves offer an all-bronze body, stainless steel strainer and seat. They comply with ASSE 1003 and CSA B356 standards. They are listed with IAPMO and City of Los Angeles. Designed for easy in-line servicing, 36CLF models come standard with a clean-out plug on the housing's bottom. Both seat disc and strainer can be maintained via the clean-out plug using a 1 1/2" hex socket. Available with or without gauge tapping and gauge.

FEATURES

- Dependable Cast Bronze Body
- Suitable for Supply Pressures to 400 psi
- Every Valve is 100% Factory Set and Tested
- Standard Factory Setting is 50 psi
- High and Low Pressure Model Options
- Diaphragm Suitable for 33° - 180°F Solder, Threaded, PEX B/C F1807, CPVC, and Press Connection Options
- Sealed Cage with SS Adjusting Screw for Vault Installation
- Integral Thermal Expansion Bypass
- Integral Stainless Steel Strainer
- Single and Double Union Options
- In-Line Repairable, Bottom Access
- USA Materials and Manufacture

OPTIONS

- (-P) Tapped 1/4" & Plugged
- (-G) With Pressure Gauge
- (-02) 10-35 psig
- (-03) 75-125 psig
- 36C Non-LF Materials for Non-Potable Service, such as Irrigation

APPROVALS

- ASSE 1003
- CSA B356
- NSF/ANSI 372 Lead Free
- City of Los Angeles
- IAPMO

DIMENSIONS

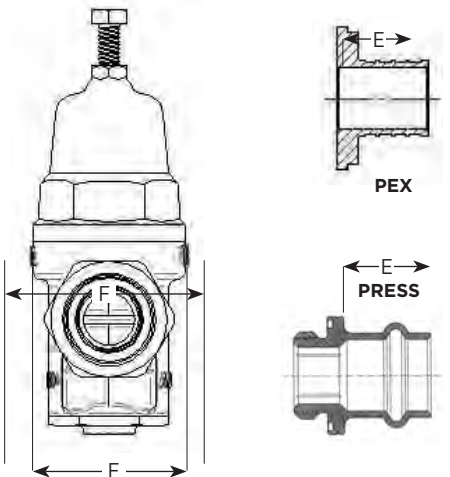
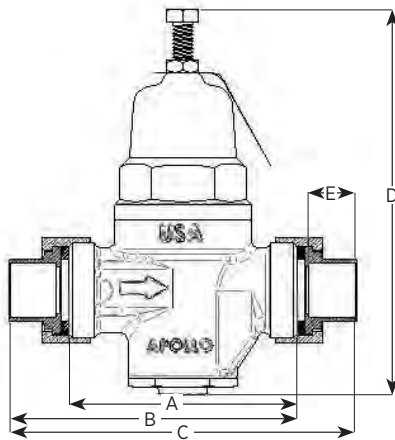

LF SERIES NUMBER	SERIES NUMBER	SIZE (IN.)	DIMENSIONS (IN.)		WT./100 (LB.)
			LENGTH	A	
FNPT INLET X OUTLET (NO UNION)					
36CLF-203-01	36C-203-01	1/2	3.63	1.62	200
36CLF-204-01	36C-204-01	3/4	3.63	1.62	200
36CLF-205-01	36C-205-01	1	3.75	1.50	225
FNPT UNION INLET X FNPT OUTLET					
36CLF-103-01	36C-103-01	1/2	4.50	1.62	240
36CLF-104-01	36C-104-01	3/4	4.50	1.62	240
36CLF-105-01	36C-105-01	1	4.63	1.50	270
SOLDER UNION INLET X FNPT OUTLET					
36CLF-303-01	36C-303-01	1/2	4.50	1.62	240
36CLF-304-01	36C-304-01	3/4	4.50	1.62	240
36CLF-305-01	36C-305-01	1	4.63	1.50	270
CPVC UNION INLET X FNPT OUTLET					
36CLF-304-01C	36C-304-01C	3/4	4.75	1.62	240
36CLF-305-01C	36C-305-01C	1	4.41	1.50	270
DOUBLE UNION/THREADED INLET X THREADED OUTLET					
36CLF-403-01	36C-403-01	1/2	5.50	1.62	280
36CLF-404-01	36C-404-01	3/4	5.50	1.62	280
36CLF-405-01	36C-405-01	1	5.75	1.50	310
DOUBLE UNION/SOLDER INLET X SWEAT OUTLET					
36CLF-503-01	36C-503-01	1/2	5.50	1.62	280
36CLF-504-01	36C-504-01	3/4	5.50	1.62	280
36CLF-505-01	36C-505-01	1	5.75	1.50	310
DOUBLE UNION CPVC INLET X CPVC OUTLET					
36CLF-504-01C	36C-504-01C	3/4	5.37	1.62	280
36CLF-505-01C	36C-505-01C	1	5.87	1.50	310
DOUBLE UNION/PEX B/C F1807 INLET X PEX B/C (F1807) OUTLET					
36CLF-903-01	36C-903-01	1/2	5.625	1.62	280
36CLF-904-01	36C-904-01	3/4	5.625	1.62	280
36CLF-905-01	36C-905-01	1	6.125	1.62	285

*36C Series for non-potable water available. Example: 36C-203-01

WATER PRESSURE REDUCING VALVES

PRC SERIES (36CLF)

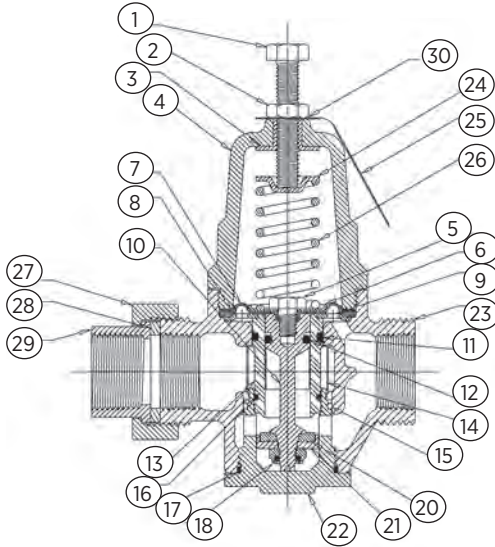

STANDARD MATERIALS LIST

1	Adjusting Bolt (Stainless Steel)	16	O-Ring (FDA Nitrile)
2	Nut (Stainless Steel)	17	O-Ring (FDA Nitrile)
3	Tee Nut (Zinc Plated Steel)	18	Lock Nut (300 Series SS)
4	Cap (Noryl™)	19	Seat Ring (300 Series SS)
5	Hex Bolt (300 Series SS)	20	Seat Disc (FDA EPDM)
6	Pressure Plate (Brass)	21	Disc Holder (LF Brass)
7	Diaphragm (FDA EPDM w/Polyester)	22	Clean-Out Plug (LF Brass)
8	Friction Ring (Brass)	23	Body, Machined (LF Cast Bronze)
9	Cartridge Ret. Washer (Brass)	24	Spring Washer (Zinc Plated Steel)
10	Stem (LF Brass)	25	Nameplate (Aluminum)
11	O-Ring (FDA Nitrile)	26	Spring (Zinc Plated Music Wire)
12	O-Ring (FDA Nitrile)	27	Union Nut (Brass)
13	Cartridge Housing (G.F. Noryl)	28	Union Washer (FDA Nitrile)
14	Screen (300 Series SS)	29	Union Tail Piece (LF Brass)
15	O-Ring (FDA Nitrile)	30	Cage Seal (Stainless Steel)

PART NUMBER MATRIX

36CLF 36C	X	XX	X	X	X
SERIES	CONNECTION	SIZE	GAUGE	PRESSURE RANGE	OPTION
36CLF (LEAD FREE)	1 - SINGLE UNION NPT	03 - 1/2"	0 - WITHOUT GAUGE	1 - 25 - 75 PSIG RANGE	C - CPVC TAILPIECE
36C	2 - NO UNION NPT	04 - 3/4"	P - W/ GAUGE PORT PLUGGED	2 - 10 - 35 PSIG RANGE	P - PUSH*
	3 - SINGLE UNION SOLDER X NPT	05 - 1"	G - W/ GAUGE	3 - 75 - 125 PSIG RANGE	PR - PRESS**
	4 - DOUBLE UNION NPT				
	5 - DOUBLE UNION SOLDER				
	9 - DOUBLE UNION PEX B/C F1807				

* Available in Direct Connection
 ** Available in Direct Connection, and Double Union

PIPE SIZE	*FALLOFF (PSI)	PRESSURE DIFFERENTIAL (PSI)		
		25	50	75
WATER CAPACITY (GPM)				
1/2"	5	1.3	1.5	1.7
	10	4.7	5.5	6.3
	15	10.6	12.5	14.4
	20	15.3	18.0	20.7
	30	20	24	27
3/4"	5	2.1	2.5	2.9
	10	6.8	8.0	9.2
	15	13.2	15.5	17.8
	20	18.3	21.5	24.7
	30	27	31	35
1"	5	2.8	3.3	3.7
	10	8.5	10.0	11.5
	15	15.3	18.0	20.7
	20	21.3	25.0	28.8
	30	40	46	51

*Falloff is the difference between the PRV's set pressure and the flowing pressure at any given demand

FLOW CURVE

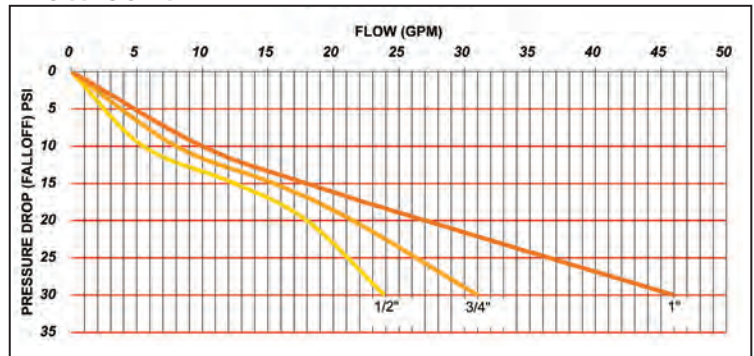

Pressure Differential is the difference between the inlet supply pressure and the adjusted outlet pressure.
Pressure Falloff is the reduction in downstream pressure from the static (set) pressure as the flow increases through the valve.

PRE SERIES (36ELF)



The Apollo® 36ELF is designed for residential and commercial applications to protect water supplies from excessive pressure. Excellent flow performance at low pressure drop. The dezincification resistant bronze body and dielectric polymer cage provide maximum corrosion resistance. Designed for easy in-line servicing with simple cartridge removal. They meet ASSE 1003 and CSA B356 standards. They are listed with IAPMO and the city of Los Angeles.

FEATURES

- Balanced Piston Design
- Sealed Cage for Vault Installations
- Built-In Thermal Expansion Bypass
- Integral Stainless Steel Strainer
- Modular Seat Disc and Strainer Cartridge
- Control Pressure Ranges: 15-75 psi and 75-150 psi
- NPT, Solder, PEX A, PEX B/C, CPVC and Press and Push Connections
- Single, Double & Less Union Configurations Available
- Maximum Supply Pressure: 400 psig
- Push & Press Max Supply Pressure: 200 psig
- Working Temperature Range: 33° - 180°F
- **100% Manufactured in USA**

OPTIONS

- (-B) Bronze Cap **NEW!**
- (-X2) PEX A (F1960) Cold Expansion **NEW!**
- 36E Non-LF Materials for Non-Potable Service, Such as Irrigation

APPROVALS

- ASSE 1003
- CSA B356
- NSF/ANSI 372 Lead Free
- NSF/ANSI 61 Water Quality
- IAPMO

DIMENSIONS

CONNECTION TYPE	SIZE (IN.)	DIMENSIONS (IN.)						WEIGHTS (LB.)		
		A	B	C	D	E	F	SINGLE UNION	DOUBLE UNION	
Thread - FNPT	1/2	Solder	3.625	4.58	5.53	6	0.95	2.75	2.4	2.75
		CPVC	3.625	4.33	5.03	6	0.70	2.75	2.4	2.75
		PEX A	3.625	4.83	6.03	6	1.20	2.75	2.7	3.01
		PEX B/C	3.625	4.65	5.67	6	1.02	2.75	2.7	2.99
		Push	3.625	4.86	6.09	6	1.23	2.75	2.9	3.02
		Push*	3.625	5.10	6.57	6	1.47	2.75	2.8	2.92
		Press	3.625	4.62	5.61	6	0.99	2.75	2.9	3.02
		Press*	3.625	4.97	6.31	6	1.34	2.75	2.4	2.75
		Thread - FNPT	3.625	4.56	5.49	6	0.93	2.75	2.4	2.75
		Solder	3.625	4.56	5.49	6	0.93	2.75	2.4	2.75
Thread - FNPT	3/4	CPVC	3.625	4.55	5.47	6	0.92	2.75	2.4	2.75
		PEX A	3.625	4.83	6.03	6	1.20	2.75	2.7	3.02
		PEX B/C	3.625	4.88	6.13	6	1.25	2.75	2.7	2.98
		Push	3.625	5.41	7.19	6	1.78	2.75	2.9	3.02
		Push*	3.625	5.23	6.83	6	1.60	2.75	2.8	3.23
		Press	3.625	4.77	5.91	6	1.14	2.75	2.9	3.02
		Press*	3.625	5.13	6.63	6	1.50	2.75	2.4	2.75
		Thread - FNPT	3.625	4.69	5.75	6	1.06	3.38	2.4	2.86
		Solder	3.625	4.69	5.75	6	1.06	3.38	2.4	2.86
		Thread - FNPT	1	CPVC	3.625	4.79	5.95	6	1.16	3.38
PEX A	3.625			4.80	5.97	6	1.17	3.38	3.2	3.65
PEX B/C	3.625			5.18	6.73	6	1.55	3.38	3.1	3.56
Push	3.625			5.59	7.55	6	1.96	3.38	3.2	3.65
Push*	3.625			5.54	7.45	6	1.91	3.38	3.3	3.91
Press	3.625			4.81	5.99	6	1.18	3.38	3.2	3.65
Press*	3.625			5.25	6.87	6	1.62	3.38	2.4	2.86

*Direct Connect
PEX A (ASTM F1960) - Cold Expansion PEX | PEX B/C (ASTM F1807) - Crimp Style PEX

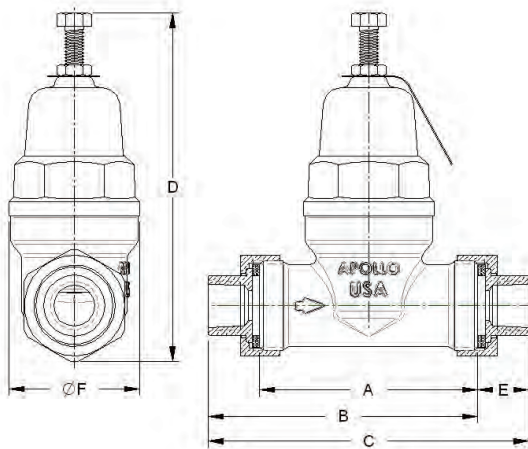

TAILPIECES

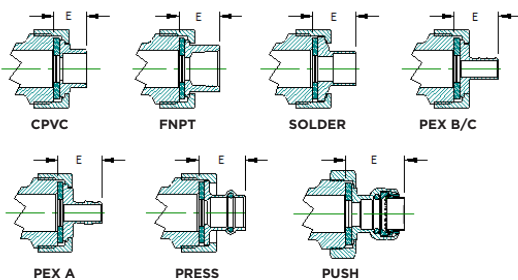

WATER PRESSURE REDUCING VALVES

PRE SERIES (36ELF-G)

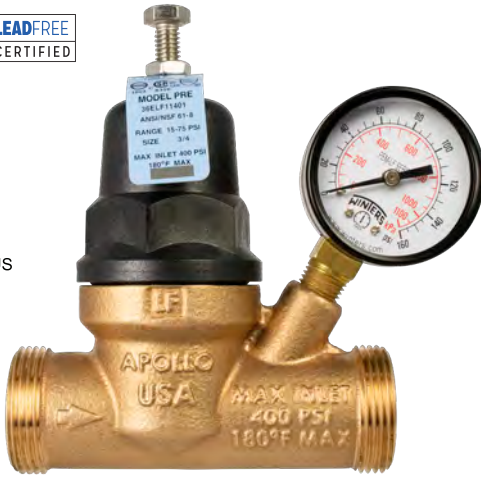

The Apollo® 36ELF-G is designed for residential and commercial applications to protect water supplies from excessive pressure. Excellent flow performance at low pressure drop. The 36ELF-G has a built in gauge that shows the downstream pressure. The dezincification resistant bronze body and dielectric polymer cage provide maximum corrosion resistance. Designed for easy in-line servicing with simple cartridge removal. They meet ASSE 1003 and CSA B356 standards. They are listed with IAPMO and the city of Los Angeles.

FEATURES

- Balanced Piston Design
- Sealed Cage for Vault Installations
- Built-In Thermal Expansion Bypass
- Integral Stainless Steel Strainer
- Modular Seat Disc and Strainer Cartridge
- Control Pressure Ranges: 15-75 psi and 75-150 psi
- NPT, Solder, PEX A, PEX B/C, CPVC and Press and Push Connections
- Single, Double & Less Union Configurations Available
- Maximum Supply Pressure: 400 psig
- Push & Press Max Supply Pressure: 200 psig
- Working Temperature Range: 33° - 180°F
- **100% Manufactured in USA**

OPTIONS

- (-B) Bronze Cap **NEW!**
- (-X2) PEX A (F1960) Cold Expansion **NEW!**
- 36E Non-LF Materials for Non-Potable Service, Such as Irrigation

APPROVALS

- ASSE 1003
- CSA B356
- NSF/ANSI 372 Lead Free
- NSF/ANSI 61 Water Quality
- IAPMO

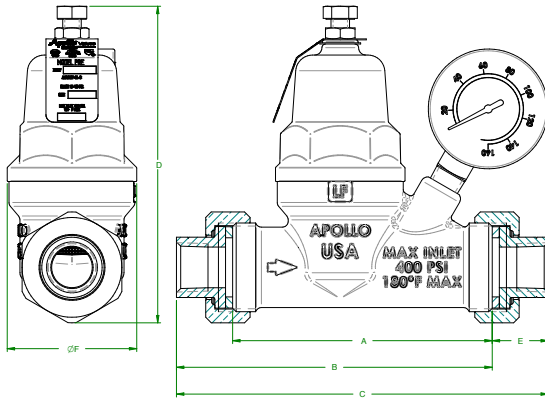

DIMENSIONS

CONNECTION TYPE	SIZE (IN.)	DIMENSIONS (IN.)						WEIGHTS (LB.)		
		A	B	C	D	E	F	SINGLE UNION	DOUBLE UNION	
Thread - FNPT	1/2	4.39	5.34	6.29	6	0.95	2.75	2.6	2.9	
		Solder	4.39	5.32	6.25	6	0.93	2.75	2.6	2.9
		CPVC	4.39	5.09	5.79	6	0.70	2.75	2.6	2.9
		PEX A	4.39	5.59	6.79	6	1.20	2.75	2.9	3.2
		PEX B/C	4.39	5.41	6.43	6	1.02	2.75	2.9	3.2
		Push	4.39	5.62	6.85	6	1.23	2.75	3.1	3.2
		Push*	4.39	5.86	7.33	6	1.47	2.75	3.0	3.1
		Press	4.39	5.38	6.37	6	0.99	2.75	3.1	3.2
		Press*	4.39	5.73	7.07	6	1.34	2.75	2.6	2.9
		Thread - FNPT	3/4	4.39	5.32	6.25	6	0.93	2.75	2.6
Solder	4.39			5.32	6.25	6	0.93	2.75	2.6	2.9
CPVC	4.39			5.31	6.23	6	0.92	2.75	2.6	2.9
PEX A	4.39			5.59	6.79	6	1.20	2.75	2.9	3.2
PEX B/C	4.39			5.64	6.89	6	1.25	2.75	2.9	3.1
Push	4.39			6.17	7.95	6	1.78	2.75	3.1	3.2
Push*	4.39			5.99	7.59	6	1.60	2.75	3.0	3.4
Press	4.39			5.53	6.67	6	1.14	2.75	3.1	3.2
Press*	4.39			5.89	7.39	6	1.50	2.75	2.6	2.9
Thread - FNPT	1			3.64	4.70	5.76	6	1.06	3.38	2.4
		Solder	3.64	4.70	5.76	6	1.06	3.38	2.4	2.9
		CPVC	3.64	4.80	5.96	6	1.16	3.38	2.4	2.9
		PEX A	3.64	4.81	5.98	6	1.17	3.38	3.2	3.7
		PEX B/C	3.64	5.19	6.74	6	1.55	3.38	3.1	3.6
		Push	3.64	5.60	7.56	6	1.96	3.38	3.2	3.7
		Push*	3.64	5.55	7.46	6	1.91	3.38	3.3	3.9
		Press	3.64	4.82	6.00	6	1.18	3.38	3.2	3.7
		Press*	3.64	5.26	6.88	6	1.62	3.38	2.4	2.9

TAILPIECES

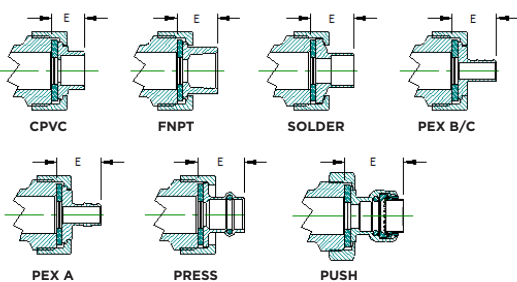

WATER PRESSURE REDUCING VALVES

PRE SERIES (36ELF / 36ELF-G)

STANDARD MATERIALS LIST

BODY	Bronze, ASTM B584
	LF Bronze, UNS 89836
CAP	Noryl™
SPRING	Steel, ASTM 228
ADJUSTING SCREW/NUT	Stainless Steel
UNION NUT	Brass, ASTM B16
TAILPIECE	Brass, ASTM B16
	LF Brass, UNS C27451
SCREEN	Stainless Steel
DIAPHRAGM	NSF Grade EPDM
SEAT DISC	NSF Grade EPDM
O-RINGS	NSF Grade EPDM

PART NUMBER MATRIX

36ELF 36E	1	X	X	XX	X	X
SERIES	STYLE	UNION	SIZE	PRESSURE RANGE	CONNECTION	OPTION
36ELF (LEAD FREE)	1	0 - NO UNION NPT	3 - 1/2"	01 - 15 - 75 PSIG RANGE	T - FNPT THREAD	B - BRONZE CAP
36E		1 - SINGLE UNION	4 - 3/4"	03 - 75 - 150 PSIG RANGE	S - SOLDER	
		2 - DOUBLE UNION	5 - 1"	WITH GAUGE (LF ONLY)	C - CPVC	
				G1 - 15 - 75 PSIG RANGE	X - PEX B/C (F1807)	
				G3 - 75 - 150 PSIG RANGE	P - PUSH*	
					PR - PRESS**	
					X2 - PEX A (F1960)	

PEX A (ASTM F1960) - Cold Expansion PEX

PEX B/C (ASTM F1807) - Crimp Style PEX

* Available in Direct Connection, Single Union x NPT, and Double Union

** Available in Direct Connection, and Double Union

FLOW CURVE

PIPE SIZE	*FALLOFF (PSI)	PRESSURE DIFFERENTIAL (PSI)		
		25	50	75
1/2"	10	10	13	16
	15	13	18	22
	20	17	23	29
	30	22	29	36
3/4"	10	16	21	26
	15	20	27	32
	20	24	32	40
	30	29	38	48
1"	10	25	33	41
	15	30	42	52
	20	34	45	56
	30	35	47	59

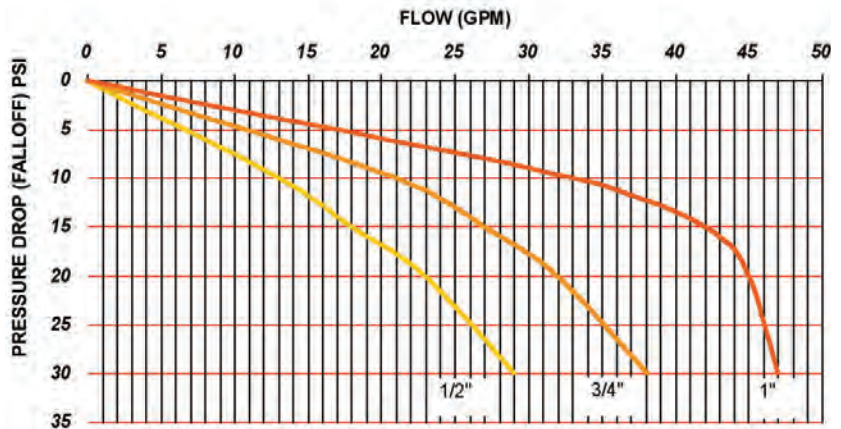

*Falloff is the difference between the PRV's set pressure and the flowing pressure at any given demand

Pressure Differential is the difference between the inlet supply pressure and the adjusted outlet pressure.

Pressure Falloff is the reduction in downstream pressure from the static (set) pressure as the flow increases through the valve.

WATER PRESSURE REDUCING VALVES

36E/LF TAILPIECE KITS (TPK)

36E/LF bodies are threaded to accept unions. TPK Tailpiece Kits allow for customization of the end connection configurations in the field. Union connections can easily be added and tailpieces can be mixed to match the requirements at the jobsite. NPT x Solder? PEX x Press? - no problem!

Each TPK includes one each tailpiece, union nut and washer.

SIZE	LEAD FREE	STANDARD	CONNECTION
1/2"	TPK12CLF	TPK12C	CPVC
1/2"	TPK12PLF	TPK12P	PUSH
1/2"	TPK12PRLF	TPK12PR	PRESS
1/2"	TPK12SLF	TPK12S	SOLDER
1/2"	TPK12TLF	TPK12T	NPT
1/2"	TPK12X2LF	-	PEX A
1/2"	TPK12XLF	TPK12X	PEX B/C
3/4"	TPK34CLF	TPK34C	CPVC
3/4"	TPK34PLF	TPK34P	PUSH
3/4"	TPK34PRLF	TPK34PR	PRESS
3/4"	TPK34SLF	TPK34S	SOLDER
3/4"	TPK34TLF	TPK34T	NPT
3/4"	TPK34X2LF	-	PEX A
3/4"	TPK34XLF	TPK34X	PEX B/C
1"	TPK1CLF	TPK1C	CPVC

SIZE	LEAD FREE	STANDARD	CONNECTION
1"	TPK1PLF	TPK1P	PUSH
1"	TPK1PRLF	TPK1PR	PRESS
1"	TPK1SLF	TPK1S	SOLDER
1"	TPK1TLF	TPK1T	NPT
1"	TPK1X2LF	-	PEX A
1"	TPK1XLF	TPK1X	PEX B/C
1-1/4"	TPK114PRLF	TPK114PR	PRESS
1-1/4"	TPK114SLF	TPK114S	SOLDER
1-1/4"	TPK114TLF	TPK114T	NPT
1-1/2"	TPK112PRLF	TPK112PR	PRESS
1-1/2"	TPK112SLF	TPK112S	SOLDER
1-1/2"	TPK112TLF	TPK112T	NPT
2"	TPK2PRLF	TPK2PR	PRESS
2"	TPK2SLF	TPK2S	SOLDER
2"	TPK2TLF	TPK2T	NPT



36E/LF SPACER



SPACERS DESIGNED TO ALLOW SYSTEM FLUSH PRIOR TO INSTALLING WPRV

36ESP1 - 1" Connections
36ESP114 - 1-1/4" Connections

WATER PRESSURE REDUCING VALVES

PRE SERIES (36ELF)
LARGE DIAMETER



The new large diameter Apollo® 36ELF Lead Free Pressure Reducing Valve is designed to conserve water and protect water distribution systems by automatically reducing elevated supply pressures. The dezincification resistant bronze body, stainless steel adjusting screw and dielectric polymer cage provide maximum corrosion resistance. Designed for easy in-line servicing with simple cartridge removal.

FEATURES

- Balanced Piston Design
- SS Adjusting Screw & Nut
- Sealed Cage for Vault Installations
- Built-In Thermal Expansion Bypass
- Large Area Integral Stainless Steel Strainer
- Modular Seat Disc and Strainer Cartridge
- Control Pressure Ranges: 15-75 psi and 75-150 psi
- High Flow / High Efficiency Design
- NPT and Solder Connections
- **Union Press Connections: 1-1/4" - 2" (Max 300 psi) NEW!**
- Factory Tested and Preset at 60 psi
- Single Union, Double Union and Less Union Configurations Available
- **100% Manufactured in USA – ARRA Compliant**

OPTIONS

- **(-B) Bronze Cap NEW!**
- (-P) Tapped 1/4" & Plugged
- (-G) With Pressure Gauge

APPROVALS

- ASSE 1003
- CSA B356
- IAPMO/UPC
- NSF/ANSI 372 Lead Free
- NSF/ANSI 61 Water Quality

DIMENSIONS

SIZE (IN.)	DIMENSIONS (IN.)						SINGLE UNION WT.	DOUBLE UNION WT.
	A	B	C	D	E	F		
THREADED								
1-1/4"	5.5	6.62	7.74	10	1.12	3.375	7.22	8.34
1-1/2"	5.5	6.80	8.1	10	1.30	3.375	7.61	8.92
2"	5.5	6.93	8.36	10	1.43	3.375	9.2	11.6
SOLDER								
1-1/4"	5.5	6.62	7.74	10	1.12	3.375	7.22	8.34
1-1/2"	5.5	6.80	8.1	10	1.30	3.375	7.61	8.92
2"	5.5	6.93	8.36	10	1.43	3.375	9.2	11.6

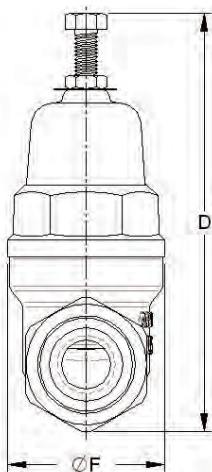
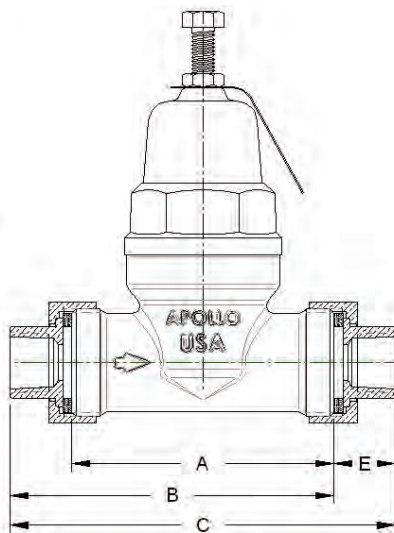

WATER PRESSURE REDUCING VALVES

**PRE SERIES (36ELF)
LARGE DIAMETER**

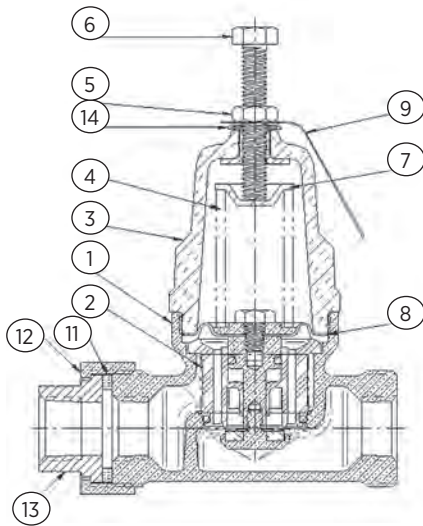

STANDARD MATERIALS LIST

1	LF Body (Bronze, ASTM B584-C89836)
2	Assy, Cartridge (Noryl™/LF Brass/EPDM)
3	Cap (Noryl™)
4	Spring (Music Wire ASTM A228)
5	Nut (Stainless Steel)
6	Bolt (Stainless Steel)
7	Washer, Spring (Steel Plated)
8	Friction Ring (Lead Free Brass)
9	Nameplate (Aluminum)
11	Washer (BUNA-N)
12	Nut, Union (Brass)
13	Tailpiece (Lead Free Brass)
14	Cage Seal (Nitrile)

PART NUMBER MATRIX

36ELF 36E	1	X	X	X	X	X	X
SERIES	STYLE	UNION	SIZE	OPTION	PRESSURE RANGE	CONNECTION	OPTION
36ELF (LEAD FREE)	1	0 - NO UNION (NPT)	6 - 1-1/4"	0 - NO GAUGE	1 - 15-75 PSIG	T - FNPT THREAD	BLANK - STANDARD POLYMER CAP
36E		1 - SINGLE UNION	7 - 1-1/2"	P - TAPPED & PLUGGED	3 - 75-150 PSIG	S - SOLDER	B - BRONZE CAP
		2 - DOUBLE UNION	8 - 2"	G - W/ GAUGE		PR - PRESS	Y - W/ WYE STRAINER

PIPE SIZE	FALL-OFF (PSI)	PRESSURE DIFFERENTIAL (PSI)		
		25	50	75
GPM				
1-1/4"	10	35	47	59
	15	58	77	96
	20	85	113	141
	30	99	132	165
1-1/2"	10	66	88	110
	15	81	108	135
	20	96	128	160
	30	104	138	172
2"	10	81	108	135
	15	109	145	181
	20	116	155	194
	30	128	170	212

FLOW CURVE

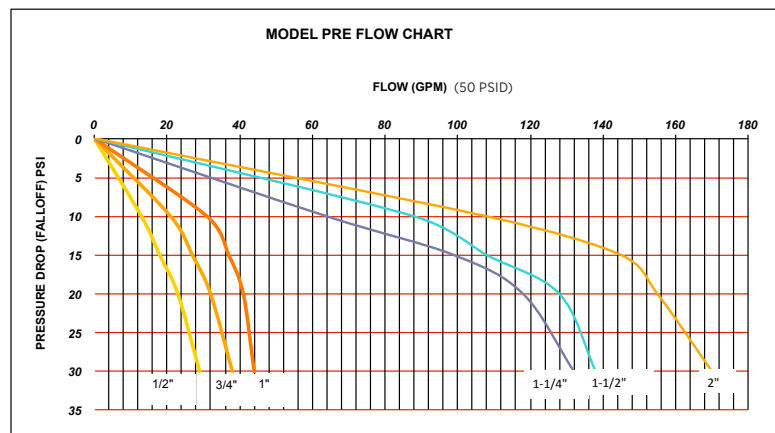

Pressure Differential is the difference between the inlet supply pressure and the adjusted outlet pressure.
Pressure Falloff is the reduction in downstream pressure from the static (set) pressure as the flow increases through the valve.

WATER PRESSURE REDUCING VALVES

PRH SERIES (36HLF)



Apollo® 36HLF Series pressure reducing valves offer high performance in heavy-duty applications. They're designed with a larger diaphragm and orifice area to yield the highest water flow water capacities in the industry.

The 36HLF pressure reducing valves' integral bypass protects against thermal expansion. Built for extended service, these models include bronze body construction and stainless steel replaceable seat. They meet ASSE 1003 and CSA B356 standards. They are listed with IAMPO and city of Los Angeles.

These heavy-duty valves are available with optional in-line strainer and 150 lb. ANSI B16.24 integral bronze flange connections. (2-1/2" and 3" only)

FEATURES

- Bronze Body and Spring Cage for Superior Corrosion Resistance and Dependability
- SS Fasteners, Spring, Seat, and Adjustment Screw
- Sealed Spring Cage for Vault Installations
- Standard Factory Setting is 50 psi
- Operating Temperature: 33° - 180°F Suitable for Supply Pressures to 400 psi
- Every Valve is 100% Factory Set and Tested
- Integral Thermal Expansion Bypass
- In-line Repairable, Bottom Access
- **USA Materials and Manufacture**

OPTIONS

- (-02) Low Pressure 10-35 psi
- (-03) High Pressure 75-125 psi
- Bronze Stainer
- 36HLF700 Series w/ 150# ANSI Flanges

APPROVALS

- ASSE 1003
- CSA B356
- NSF/ANSI 372 Lead Free
- IAMPO

DIMENSIONS

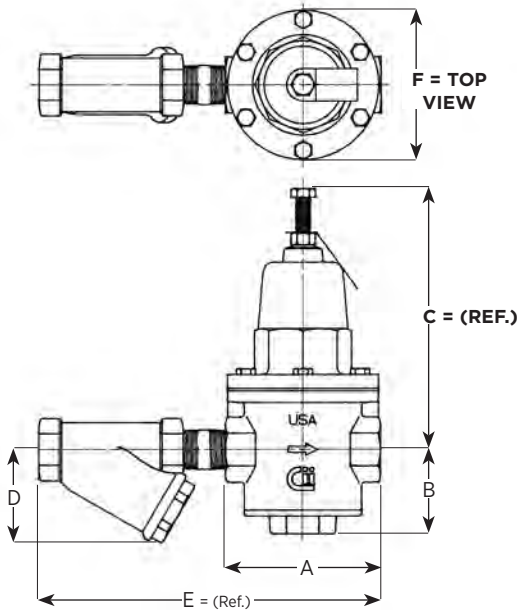

SIZE (IN.)	DIMENSIONS (IN.)						WEIGHT (LB.)	
	A	B	C	D	E	F	W / STRAINER	W/O STRAINER
THREADED								
1/2"	4.13	2.25	7.00	1.88	8.38	4.00	7.0	6.00
3/4"	4.13	2.25	7.00	2.44	9.00	4.00	8.0	6.00
1"	4.81	2.31	7.50	4.00	10.25	4.69	12.0	8.00
1-1/4"	6.75	3.81	10.00	3.38	12.50	6.50	29.0	24.00
1-1/2"	6.75	3.19	10.00	3.88	13.13	6.50	29.0	23.00
2"	8.13	3.50	12.50	4.63	16.00	7.63	47.0	38.00
2-1/2"	8.13	3.50	12.50	5.94	16.69	7.63	49.0	37.00
3"	10.38	3.94	15.13	6.94	20.50	9.75	87.0	70.00
FLANGED								
2-1/2"	10.38	3.50	12.50	7.13	21.69	7.63	105.0	55.00
3"	12.50	3.94	15.13	8.13	24.50	9.75	136.0	92.00

WATER PRESSURE REDUCING VALVES

PRH SERIES (36HLF)

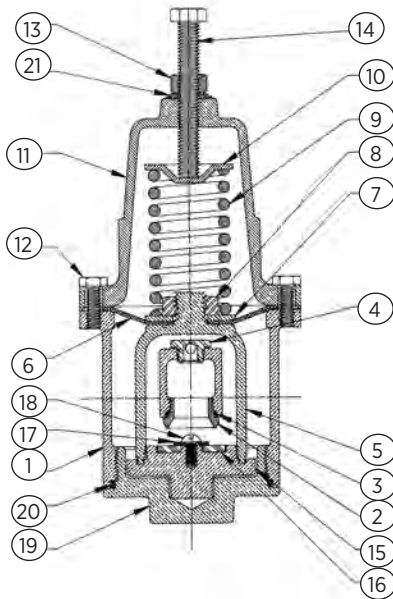

STANDARD MATERIALS LIST

1	Body (LF Bronze)
2	Seat (SS)
3	Seat O-Ring (Nitrile)
4	Bypass Assembly
5	Yoke (LF Bronze)
6	Diaphragm (Nitrile w/Nylon Reinforcement)
7	Diaphragm Washer (SS)
8	Diaphragm Nut (SS)
9	Spring (SS)
10	Spring Retainer (SS)

11	Cap (Bronze)
12	Cap Bolts (SS)
13	Lock Nut (SS)
14	Adjustment Screw (SS)
15	Seat Disc Holder (LF Bronze)
16	Seat Disc (EPDM)
17	Seat Disc Washer (SS)
18	Seat Screw (SS)
19	Bottom Cover (LF Bronze)
20	Bottom Cover O-Ring (Nitrile)
21	Cage-Sealing Washer (SS)

PART NUMBER MATRIX

36HLF 36H	X	X	X	OX
SERIES	END CONNECTIONS	OPTIONS	SIZE	PRESSURE RANGE
36HLF (LEAD FREE)	2 - FNPT X FNPT (STANDARD)	0 - STANDARD	3 - 1/2"	01 - 25-75
36H	7 - FLANGED (2-1/2" - 3" ONLY)	1 - W/Y-STRAINER	4 - 3/4"	02 - 10-35
			5 - 1"	03 - 75-125
			6 - 1-1/4"	
			7 - 1-1/2"	
			8 - 2"	
			9 - 2-1/2"	
			0 - 3"	

PRH SERIES (36HLF)

PIPE SIZE	*FALLOFF (PSI)	PRESSURE DIFFERENTIAL (PSI)		
		25	50	75
		WATER CAPACITY (GPM)		
1/2"	5	8.5	10.0	11.5
	10	13.6	16.0	18.4
	15	17.9	21.0	24.2
	20	21.3	25.0	28.8
3/4"	5	10.6	12.5	14.4
	10	20.4	24.0	27.6
	15	28.1	33.0	38.0
	20	34.0	40.0	46.0
1"	5	17.0	20.0	23.0
	10	29.8	35.0	40.3
	15	40.8	48.0	55.2
	20	51.0	60.0	69.0
1-1/4"	5	21.3	25.0	28.8
	10	51.9	61.0	70.2
	15	80.8	95.0	109.3
	20	113.1	125.0	143.8
1-1/2"	5	29.8	35.0	40.3
	10	61.5	72.3	83.1
	15	90.1	106.0	121.0
	20	113.1	133.0	153.0
2"	5	55.3	65.0	74.8
	10	126.7	149.0	171.4
	15	174.3	205.0	235.8
	20	231.20	272.0	312.80
2-1/2"	5	58.7	69.0	79.4
	10	132.6	156.0	179.4
	15	200.6	236.0	271.40
	20	271.20	319.0	366.9
3"	5	80.8	95.0	109.3
	10	176	207	238.1
	15	282.5	332.4	382.3
	20	365.5	430.0	494.5

FLOW CURVE

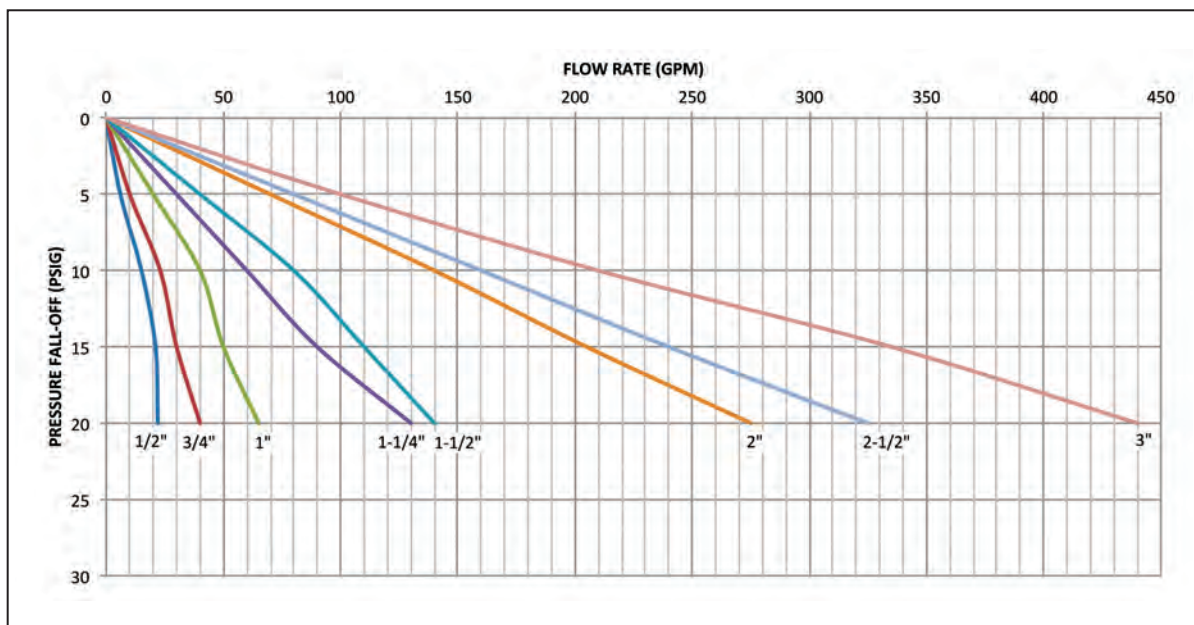

Pressure Differential is the difference between the inlet supply pressure and the adjusted outlet pressure.
Pressure Falloff is the reduction in downstream pressure from the static (set) pressure as the flow increases through the valve.

A127 SERIES



Apollo® pilot operated control valves are ideal for a wide range of commercial and industrial applications, wherever the supply pressure needs to be reduced to a lower constant pressure.

Hydraulically operated diaphragm main valve automatically controls non-corrosive, non-abrasive fluids by means of a wide range of pilots.

FEATURES

- Ductile Iron Body & Bonnet, ASTM A536 Grade 65-45-12
- NSF Epoxy Coated
- Bronze / Stainless Steel Internals
- EPDM Elastomers 40°F - 180°F
- Lead Free Components Used Throughout
- Lead Free Wye Strainer Protects Pilot System from Debris
- Isolation Ball Valves Simplify Maintenance and Troubleshooting
- Each Valve is 100% Factory Tested and Can be Set to Your Requirements
- Wide Range of Control Pilots and Functions
- Opening Speed Control is Standard
- Automatically Reduces a Higher Upstream Pressure to a Constant Lower Downstream Pressure
- Constant Outlet Pressure Regardless of Variations in Upstream Pressure or Flow
- Pilot Operated Main Valve is Not Subject to Pressure Falloff
- Outlet Pressure is Adjustable with a Single Screw
- Optional Low-Flow Bypass Models A127-LF or A727-LF (when wide extremes in flow demand are anticipated)

APPROVALS

- NSF/ANSI 372 Lead Free
- NSF/ANSI 61 Water Quality

MATERIAL OPTIONS

- Body: Ductile Iron (NSF 61 Epoxy Coated), Cast Steel, Stainless Steel, Bronze
- Pilot/Fittings: Bronze/Brass, Stainless Steel
- Tubing: Copper, Stainless Steel
- Elastomers: EPDM, Buna N, Viton

*For use with potable water, use ductile iron (NSF 61 epoxy coated) body, lead free bronze/brass pilot and fittings, copper tubing and EPDM elastomers.

OTHER CONTROL FUNCTIONS

A94	Diaphragm Check Valve
A108-2	Pressure Relief/Pressure Sustaining
A110	Differential Control
A115-2	Solenoid Control
A115-4	Solenoid Control/High Capacity Pilot
A120	Rate of Flow Control
A127LF	Pressure Reducing with Low Flow Bypass
A727	Pressure Reducing with Reduced Port
A727LF	Pressure Reducing with Reduced Port and Low Flow Bypass
A800	Float Controlled On/Off Service
A810	Float Controlled, Modulating
A22 / A88	Digital Electronic Control, Regulates Pressure, Flow or Level

*Contact customer service for assistance with sizing, selection and model numbers

**See brochure ACVBR9000 for additional information

VALVE SIZES	
Globe Flanged	1-1/4" - 24"
Angle Flanged	1-1/4" - 16"
Globe / Angle Threaded	1-1/4" - 3"
Globe / Angle Grooved	1-1/2" - 6"
SERVICE RATINGS - DUCTILE IRON	
150# Flanged	250 psi MAWP
300# Flanged	640 psi MAWP
Threaded	640 psi MAWP
Grooved	300 psi MAWP

*6" grooved globe style only

WATER PRESSURE REDUCING VALVES

A127 SERIES

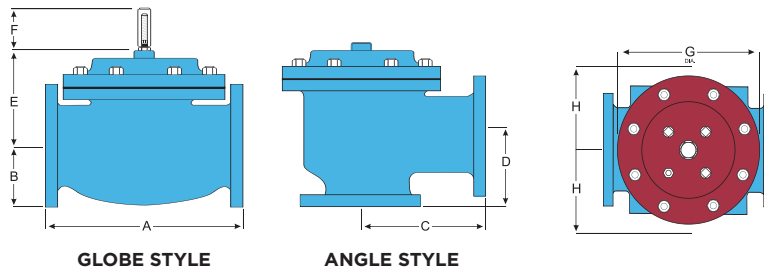

DIMENSIONS

SIZE (IN.)	END CONNECTIONS A				END CONNECTIONS C				END CONNECTIONS D				E	H
	SCREWED	GROOVED	150# FLANGED	300# FLANGED	SCREWED	GROOVED	150# FLANGED	300# FLANGED	SCREWED	GROOVED	150# FLANGED	300# FLANGED	ALL	ALL
1-1/4 - 1-1/2	8-3/4	8-3/4	8-1/2	8-3/4	4-3/8	4-3/8*	4-1/4	4-3/8	3-1/8	3-1/8*	3	3-1/8	6	10
2	9-7/8	9-7/8	9-3/8	9-7/8	4-3/4	4-3/4	4-3/4	5	3-7/8	3-7/8	3-7/8	4-1/8	6	11
2-1/2	10-1/2	10-1/2	10-1/2	11-1/8	6	6	6	6-3/8	4	4	4	4-3/8	7	11
3	13	13	12	12-3/4	6-1/2	6-1/2	6	6-3/8	4-1/2	4-1/2	4	4-3/8	6-1/2	11
4	—	15-1/4	15	15-5/8	—	7-5/8	7-1/2	7-13/16	—	5-5/8	5-1/2	5-13/16	8	12
6	—	20	17-3/4	18-5/8	—	—	10	10-1/2	—	—	6	6-1/2	10	13
8	—	—	25-3/8	26-3/8	—	—	12-11/16	13-3/16	—	—	8	8-1/2	11-7/8	14
10	—	—	29-3/4	31-1/8	—	—	14-7/8	15-9/16	—	—	11-3/8	12-1/16	15-3/8	17
12	—	—	34	35-1/2	—	—	17	17-3/4	—	—	11	11-3/4	17	18
14	—	—	39	40-1/2	—	—	—	—	—	—	—	—	18	20
16	—	—	40-3/8	42	—	—	20-13/16	21-5/8	—	—	15-11/16	16-1/2	19	20
24	—	—	62	63-3/4	—	—	—	—	—	—	—	—	27	28-1/2

*Grooved End Not Available in 1-1/4"

W-8078-00 SERIES



These pressure gauges are used for testing water pressure. Temp. Range: 50°-130° F - P/N W807800. Includes a high-pressure indicator.



W-8078-00

MODEL NUMBER	LF MODEL NUMBER	CONNECTION	PRESSURE RANGE	NET WT. (LBS.)
W-8078-00	—	3/4" hose thread	0-300 psig	.46
—	W-2799-00	1/4" NPT	0-160 psig	.70



W-2799-00

"Apollo"[®]

DOUBLE CHECKS

4A/4ALF-100	I-3
4A/4ALF-600	I-4

REDUCED PRESSURE PRINCIPLE

4A/4ALF-200	I-5
40-200-S	I-6
4A/4ALF-700	I-7

PRESSURE VACUUM BREAKER

4A/4ALF-500	I-8
4A/4ALF-900	I-9

DOUBLE CHECKS (LBF)

4ALF-100	I-10
4S - 4SG - 4SGLF	I-11
4ANLF-100	I-12
4ALF-600	I-13
4S - 4SG - 600	I-14
4ANLF-600	I-15

REDUCED PRESSURE PRINCIPLE (LBF)

4ALF-200	I-16
4ANLF-200	I-17
4ALF-700	I-18
4ANLF-700	I-19

ATMOSPHERIC VACUUM BREAKERS

38/38LF-100	I-20
38-200	I-20

DCAP

4A/4ALF - 400	I-21
---------------	------

DUAL CHECKS

4ALF-300	I-22
4FP-300	I-23
40/40LF-300	I-23

HOSE CONNECTION VACUUM BREAKER

38LF-314	I-24
38LF-414	I-24
38/38LF-304	I-25
38-500	I-25

FREEZE PROTECTION

40/40LF-000	I-26
-------------	------

CARBONATED BEVERAGE BACKFLOW	I-27
------------------------------	------

AIR GAP DEVICES

AGD	I-28
-----	------

BACKFLOW PREVENTION



WATERWORKS
RP 4AN SERIES



PLUMBING
RP 4A SERIES



FIRE PROTECTION
DCDA 4A SERIES



IRRIGATION
PVB 4A SERIES

TYPE OF DEVICE	SERIES	APPLICATION				
		BACK SIPHONAGE	BACK PRESSURE	CONTINUOUS PRESSURE	AESTHETIC HAZARD	HEALTH HAZARD
DOUBLE CHECK VALVE	DCLF 4A DCLF 4AN DCLF 4SG, DCLF 4S	X	X	X	X	
DOUBLE CHECK DETECTOR ASSEMBLY	DCDALF 4A DCDALF 4AN DCDA 4SG, DCDA 4S	X	X	X	X	
REDUCED PRESSURE PRINCIPLE	RPLF 4A	X	X	X	X	X
REDUCED PRESSURE PRINCIPLE (N & V FLOW)	RPLF 4AN	X	X	X	X	X
REDUCED PRESSURE PRINCIPLE (STAINLESS STEEL)	RPS 40	X	X	X	X	X
REDUCED PRESSURE DETECTOR ASSEMBLY	RPDALF 4A RPDALF 4AN	X	X	X	X	X
ATMOSPHERIC VACUUM BREAKER	AVB1, AVB1LF AVB2	X			X	X
PRESSURE VACUUM BREAKER	PVB 4A, PVBLF 4A	X		X	X	X
SPILL RESISTANT PRESSURE VACUUM BREAKER	SVB 4A, SVB 4ALF	X		X	X	X
DUAL CHECK	DUC 4ALF DUC 4FP DUC40, DUC4LF40	X	X	X	X	
DUAL CHECK W/ ATMOS. PORT	DCAP 4A, DCAP 4ALF	X	X	X	X	
CARBONATED BEVERAGE BACKFLOW PREVENTER	CBBP	X	X	X	X	
HOSE CONNECTION VACUUM BREAKER	HBV2, HBV2LF	X	X*		X	X
ANTI FREEZE HOSE CONN. VACUUM BREAKER	HBVAF2, HBVAF2LF	X	X*		X	X
HOSE CONNECTION BACKFLOW PREVENTER	HBDUC, HBDUCLF	X	X*		X	X
LAB FAUCET VACUUM BREAKER	LFDUCLF	X	X		X	

* Limited back pressure to 10' head
** Check with local authorities having jurisdiction

SEE **BFCA9000** FOR ADDITIONAL INFORMATION INCLUDING WEIGHTS, DIMENSIONS AND PRESSURE LOSS CURVES.

VISIT **CONBRA.CO/BACKFLOWAPPROVALS** FOR UP-TO-DATE AGENCY APPROVALS.

DC 4A / DCLF 4A SERIES
DOUBLE CHECK VALVE BACKFLOW PREVENTER ASSEMBLY



The Apollo® Model DC 4A or DCLF 4A Double Check Valves are designed to prevent contamination of the potable water supply due to back-siphonage or backpressure from substances that are objectionable, but non-health hazards. The modular check valve captured spring cartridges have replaceable seats and reversible silicone seat discs. Ball valve shut-offs with stainless steel handles and nuts are standard.

OPERATION

During normal flow conditions, the two check valves are held off their seats, supplying water downstream. Each check valve is designed to maintain a minimum of 1 psi across the valve during normal operation. Should the downstream pressure increase to within 1 psi of supply pressure, both check valves will close to prevent a backflow condition.

FEATURES

- Low Pressure Loss
- Captured Spring Cartridge Check Valves
- Compact, Yet Easy to Maintain
- Ball Valve Shut-Offs w/ SS Handles & Nuts Standard
- Top Access for Fast Testing & Maintenance
- Threaded Testcock Protectors
- Corrosion Resistant
- No Special Tools Required
- 5 Year Warranty
- Lead-Free Option
- Chloramine-Resistant Elastomers
- **Designed, Manufactured, Assembled and Tested in the USA**

APPROVALS

- Horizontal and Vertical Up Approvals
- AWWA C510
- UL, ULC Classified (T2ST Option or Less Shutoffs)
- Approved by the Foundation for Cross-Connection Control and Hydraulic Research at the University of Southern California
- ASSE 1015
- IAPMO
- CSA
- NSF/ANSI 61 Water Quality (4ALF only)
- NSF/ANSI 372 Lead Free (4ALF only)

STANDARD MATERIALS LIST

BODY, CAPS	Bronze C84400/LF C89836
BV SHUT-OFFS TEST COCKS	Bronze C84400 or LF C87800
CHECK VALVES	Glass-Filled PPO
SPRINGS	300 Series Stainless Steel
SEAT DISCS	Chloramine-Resistant Silicone
O-RINGS	Chloramine-Resistant EPDM
BV HANDLES	Stainless Steel

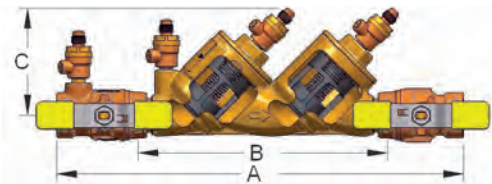

SLOW CLOSE WITH MONITOR SWITCHES
T2ST OPTION (1-1/2" AND 2" ONLY)
SEE SS1396 FOR DIMENSIONS

PERFORMANCE RATING

- Maximum Working Pressure: 175 psi
- Temperature Range: 33° to 180°F

PART NUMBER MATRIX

4A X	1 X	X	XX	X
	Y-STRAINER	SIZE	SHUT-OFF VALVES	OPTIONS (CAN BE COMBINED)
4A - STANDARD	0 - STANDARD	3 - 1/2"	A2 - W/BALL VALVES (STANDARD)	F - SAE THREADED TEST COCKS (STANDARD 1/2" -2")
4ALF - LEAD FREE	1 - W/ Y-STRAINER (SHIPPED LOOSE)	4 - 3/4"	A4 - W/UNION BALL VALVES (3/4" - 2")	LL - SS LOCKING LEVER HANDLES
		5 - 1"		PR - PRESS CONNECTIONS (FACTORY INSTALLED)
		6 - 1-1/4"		P - PUSH (3/4" -1") CONNECTIONS (FACTORY INSTALLED)
		7 - 1-1/2"	EXAMPLE: 4A 104 A4LL = 3/4" double check valve assembly with union ball valves with locking lever handles	
		8 - 2"		

DIMENSIONS

MODEL NO. PART NO. SIZE	4A 103 A2F DC 4A 12 1/2"	4A 103 A2F DC 4A 12 15 MM.	4A 104 A2F DC 4A 34 3/4"	4A 104 A2F DC 4A 34 20 MM.	4A 105 A2F DC 4A 1 1"	4A 105 A2F DC 4A 1 25MM.	4A 106 A2F DC 4A 114 1-1/4"	4A 106 A2F DC 4A 114 32 MM.	4A 107 A2F DC 4A 112 1-1/2"	4A 107 A2F DC 4A 112 40 MM.	4A 108 A2F DC 4A 2 2"	4A 108 A2F DC 4A 2 50 MM.
A*	10-7/8	276	12-5/8	321	14-5/8	371	17-1/2	445	18	457	20-1/8	511
B	7-3/8	187	8-1/2	215	9-1/2	241	11-3/4	298	11-5/8	295	12-3/4	324
C	3-1/4	83	3-1/2	89	4	100	4-1/2	114	4-1/2	114	5	127
D	2-1/2	64	3	76	3-1/4	83	4-3/4	121	4-3/4	121	5-3/8	136
WEIGHTS	LB.	KG.	LB.	KG.	LB.	KG.	LB.	KG.	LB.	KG.	LB.	KG.
Net Wt.	4.1	1.9	5.4	2.5	9.0	4.0	9.1	4.1	12.9	5.9	16.5	7.5

*For T2ST Option, Union Ball Valve, Press, and Push connection dimensions, see submittal sheets.

DCDA2 4AST / DCDA2LF 4AST SERIES

DOUBLE CHECK DETECTOR BACKFLOW PREVENTER ASSEMBLY

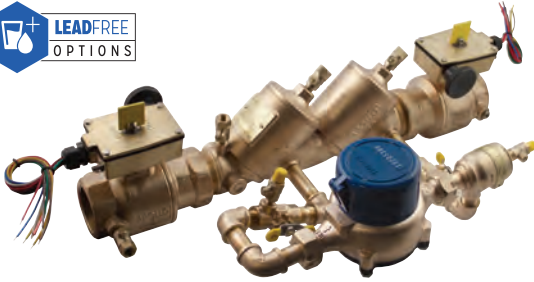

The Apollo® Model DCDA2 4AST or DCDA2LF 4AST Lead Free* 1-1/2" - 2" Double Check Detector Assembly consists of a mainline double check valve with a Type 2 bypass consisting of a single check (SCV) and meter bypassing the mainline second check to prevent backflow while accurately measuring all flows up to 2 gpm while the mainline 2nd check remains closed. The pressure drop across the assembly shall be documented by independent approval agencies. The assembly shall prevent contamination of the potable water supply due to back-siphonage or backpressure from substances that are non-health hazards. This Made in America assembly features Apollo® UL® Listed, slow-close, full open port, gear operated ball valves with integral tamper switches and carries the five-year Apollo® factory warranty.

STANDARD MATERIALS LIST

BODY, CAPS, BALL VALVE SHUTOFFS, TEST COCKS	Bronze C84400 or C89836 or C87800 (Lead Free*)
CHECK VALVE CARTRIDGES	Glass-Filled PPO
SPRINGS	300 Series Stainless Steel
SEAT DISCS	Chloramine-Resistant Silicone
O-RINGS	Chloramine-Resistant EPDM

DIMENSIONS

SIZE (IN.)	DIMENSIONS (IN.)				WT. (LB.)
	A	B	C	D	
1-1/2"	22-1/4	2-5/8	9-3/4	7-5/8	35.2
2"	23-3/4	2-5/8	10	8	45.8

FEATURES

- Low Pressure Loss Documented By Independent Approval Agencies
- Easily Removable Modular Check Valve Cartridges
- Captured Stainless Steel Springs
- Apollo® UL® Listed, Slow-Close, Full Open Port, Gear Operated Ball Valves with Integral Tamper Switches
- Top-Mounted Test Cocks for Easy Testing
- No Special Tools Required
- Chloramine-Resistant Elastomers
- **Designed, Cast, Machined, Assembled and Tested in the USA**
- Short Lay-Length for Small Spaces
- Pre-Wired Tamper (Supervisory) Switches
- 5 Year Warranty

PERFORMANCE RATING

- Maximum Working Pressure: 175 psi
- Temperature Range: 33° to 140°F
- Hydrostatic Test Pressure: 350 psi

APPROVALS

- ASSE 1048 (Horizontal & Vertical Up)
- UL® Classified (Horizontal & Vertical Up)
- C-UL® Classified (Horizontal & Vertical Up)
- Approved by the Foundation for Cross-Connection Control and Hydraulic Research at the University of Southern California. (Horizontal & Vertical Up)
- NSF/ANSI 61 Water Quality (4ALF only)
- NSF/ANSI 372 Lead Free (4ALF only)

PART NUMBER MATRIX

4A X	6 X	X	X 2ST
	BYPASS SIDE	SIZE	METER OPTION
4A - STANDARD	2 - BYPASS LINE ON RIGHT SIDE (STANDARD - AS SHOWN)	7 - 1-1/2"	C - CUBIC FT/MIN
4ALF - LEAD FREE	4 - BYPASS LINE ON LEFT SIDE	8 - 2"	E - GPM
			G - NO METER

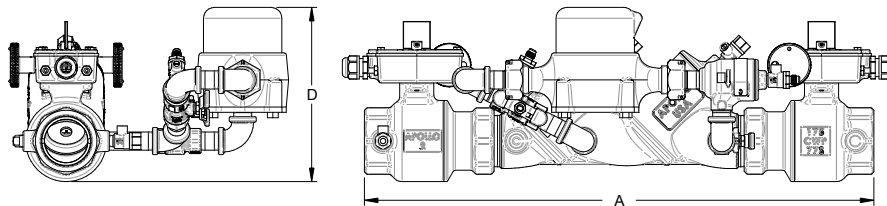
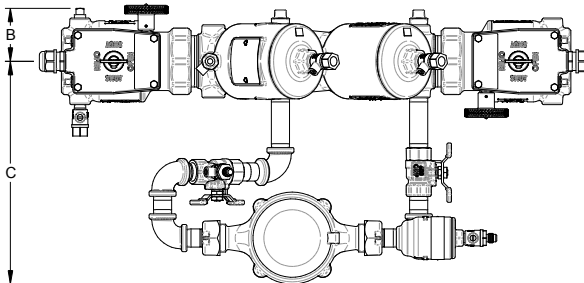

RP 4A / RPLF 4A SERIES

REDUCED PRESSURE PRINCIPLE BACKFLOW PREVENTER ASSEMBLY

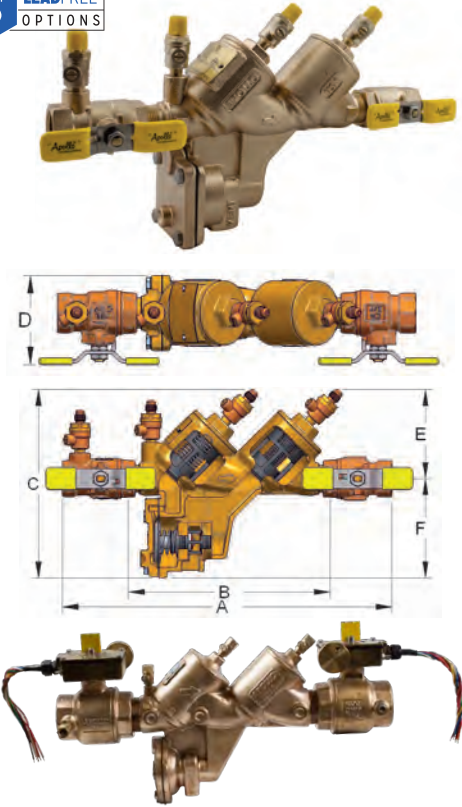

**SLOW CLOSE WITH MONITOR SWITCHES
T2ST OPTION (1-1/2" AND 2" ONLY)
SEE SS1397 FOR DIMENSIONS**

The Apollo® Series RP 4A or RPLF 4A Reduced Pressure Principle Backflow Preventer is designed to give maximum protection against backflow caused by either back-pressure or back-siphonage from substances that are hazardous. The durable but economical device is easily maintained in the line with modular check cartridge assemblies that require no special tools. It consists of two independently acting spring-loaded check valves with an automatic differential relief valve located between the check valves. All test cocks are mounted at the top of the unit to assure easy access during repair and maintenance when unit is installed in tight places.

FEATURES

- Maximum Protection Against Back-Pressure/Back-Siphonage
- Modular Check Valve Cartridges w/ Easily Replaced Parts
- Reversible/Removable Chloramine-Resistant Silicone Seat Discs
- Low Head Pressure Loss
- Top Mounted Test Cocks
- Threaded Testcock Protectors
- Internal Sensing Passage
- Modular Captured Spring Relief Valve
- Lead Free Option
- Standard with Full Port Ball Valves with Stainless Steel Handles
- Corrosion Resistant
- Optional Air Gap Drain
- **Designed, Cast, Machined, Assembled and Tested in the USA**
- 5 Year Warranty

PERFORMANCE RATING

- Maximum Working Pressure: 175 psi
- Operating Temperature Range: 33° to 180°F

APPROVALS

- ASSE 1013
- CSA B64.4
- Federal Public Law 111-380
- AWWA C511
- UL, ULC Classified (T2ST Option or Less Shutoffs)
- Approved by the Foundation for Cross-Connection Control and Hydraulic Research at the University of Southern California
- Horizontal Installation Approvals on 1/2" thru 2"
- NSF/ANSI 61 Water Quality (4ALF only)
- NSF/ANSI 372 Lead Free (4ALF only)

STANDARD MATERIALS LIST

BODY, CAPS	Bronze (C84400/LF C89836)	DIAPHRAGM	Nitrile and Nylon
BV SHUT-OFFS, TEST COCKS	Bronze (C84400/LF C87800)	CHECK MODULES	Glass-Filled PPO
SPRINGS	300 Series SS	O-RINGS	Chloramine-Resistant EPDM
SEAT DISCS	Chloramine-Resistant Silicone	BALL VALVE HANDLES	Stainless Steel

Contact local water authorities for installation/service requirements.

PART NUMBER MATRIX

4A X	2 X	X	XX	X
	Y-STRAINER	SIZE	SHUT-OFF VALVES	OPTIONS (CAN BE COMBINED)
4A - STANDARD	0 - STANDARD	3 - 1/2"	A2 - W/BALL VALVES (STANDARD)	F - SAE THREADED TEST COCKS (STANDARD 1/2")
4ALF - LEAD FREE	1 - WITH Y-STRAINER (SHIPPED LOOSE)	4 - 3/4"	A4 - W/UNION BALL VALVES (3/4" - 2")	L - LEVER HANDLE (3/4" & 1" ONLY)
		5 - 1"	T2ST - TAMPER GEAR OPERATED BALL VALVE (1-1/2" - 2")	LL - LOCKING LEVER HANDLES
EXAMPLE: 4A 215 A4LL = 1" reduced pressure backflow preventer with strainer, union ball valves and locking lever handles		6 - 1-1/4"		P - PUSH CONNECTION (FACTORY INSTALLED)
		7 - 1-1/2"		PR - PRESS CONNECTION (FACTORY INSTALLED)
		8 - 2"		

DIMENSIONS

MODEL NO. PART NO. SIZE	RP4A12 4A 203 A2F 1/2"	RP4A12 4A 203 A2F 15 MM.	RP4A34 4A 204 A2F 3/4"	RP4A34 4A 204 A2F 20 MM.	RP4A1 4A 205 A2F 1"	RP4A1 4A 205 A2F 25MM.	RP4A114 4A 206 A2F 1-1/4"	RP4A114 4A 206 A2F 32 MM.	RP4A112 4A 207 A2F 1-1/2"	RP4A112 4A 207 A2F 40 MM.	RP4A2 4A 208 A2F 2"	RP4A2 4A 208 A2F 50 MM.
A*	10-7/8	276	12-5/8	321	14-5/8	371	17-1/2	445	18	457	20-1/8	511
B	7-3/8	187	8-1/2	216	9-1/2	241	11-3/4	298	11-5/8	295	12-3/4	324
C	7-1/8	181	7-3/8	187	8	203	9-7/8	251	9-7/8	251	11	279
D	2-7/8	73	3-1/8	79	3-1/4	83	5-1/8	130	5-1/8	130	5-7/8	149
E	3-1/4	83	3-1/2	89	4	100	4-1/2	114	4-1/2	114	5	127
F	3-7/8	98	3-7/8	98	4	100	5-3/8	137	5-3/8	137	6	150
WEIGHTS	LB.	KG.	LB.	KG.	LB.	KG.	LB.	KG.	LB.	KG.	LB.	KG.
Net Wt.	6.9	3.1	8.2	3.7	11.7	5.3	13.6	6.2	17.4	7.9	24.5	11.1

*For T2ST Option, Union Ball Valve, Press, and Push connection dimensions, see submittal sheets.

RPS 40 SERIES

STAINLESS STEEL REDUCED PRESSURE BACKFLOW PREVENTER ASSEMBLY

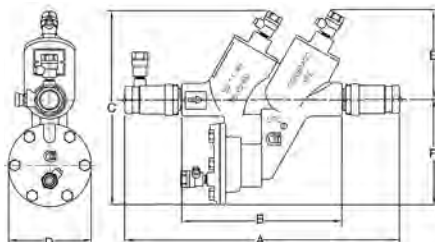
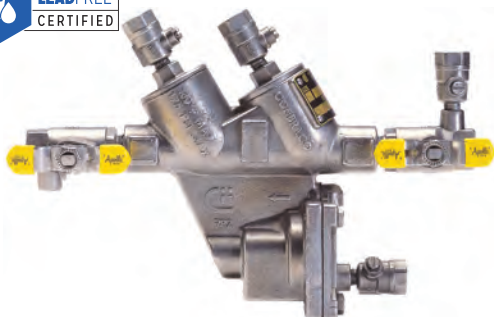

STANDARD MATERIALS LIST

BODY, COVERS	316 Stainless Steel (CF8M)
SPRINGS	Stainless Steel
FASTENERS	Stainless Steel
POPPETS	Glass-Filled Celcon®
SEAT DISCS	Silicone Rubber
DIAPHRAGM, O-RINGS	FDA Fluorocarbon
REPLACEABLE SEATS	Glass-Filled PPO
TEST COCKS & HANDLES	Stainless Steel

The Apollo® Series RPS 40 Stainless Steel Reduced Pressure Principle Backflow Preventer is designed to give maximum protection against backflow caused by either backpressure or back-siphonage from a cross-connection wherein a contaminant hazard exists (i.e. a health hazard), or a pollutant hazard exists (i.e. a non-hazard). The assembly is composed of two spring-loaded poppet type check valves and a mechanically independent, hydraulically dependent pressure differential relief valve set in an integral stainless steel body. Three of the testcocks are mounted at the top to assure easy access during repair and maintenance when unit is installed in tight places.

OPERATION

During normal flow conditions, the two check valves are held off their seats, supplying water downstream. The relief valve is held shut by supply pressure acting through the internal sensing passage, on the relief valve diaphragm. In the area between the check valves, called the zone, the pressure is maintained at approximately 7 psi lower than supply pressure. Should a back-pressure or back-siphonage condition occur, the second check valve will seal, prohibiting the backflow of water. Should the second check valve become fouled, the pressure in the zone will increase causing the differential relief valve to open to atmosphere. This will maintain the pressure in the zone at least 2 psi lower than supply pressure.

FEATURES

- Stainless Steel Body and Covers
- Easy to Install and Repair
- Internal Sensing Passage
- Low Head Loss
- Reversible/Removable Seat Discs
- Replaceable Seats
- Comes Standard with Apollo® Stainless Steel Full Port Ball Valves with Stainless Steel Handles
- Lead Free Standard
- **Designed, Cast, Machined, Assembled and Tested in the USA**
- 5 Year Warranty
- Optional Air Gap Drain

PERFORMANCE RATING

- Maximum Working Pressure: 175 psi
- Temperature Range: 33° to 180°F

APPROVALS

- Approved by the Foundation for Cross-Connection Control and Hydraulic Research at the University of Southern California
- ASSE 1013
- CSA

PART NUMBER MATRIX

40 2 X	X	TX	SX
	SIZE	SHUT-OFF VALVES	OPTIONS (CAN BE COMBINED)
0 - STANDARD	2 - 3/8"	1 - LESS BALL VALVES (UL CLASSIFIED - 3/4", 1")	LL - LOCKING LEVER HANDLES
1 - W/ SS Y-STRAINER	3 - 1/2"	2 - W/SS BALL VALVES, W/SS TEE HANDLES (STANDARD)	
(SHIPPED LOOSE)	4 - 3/4"		
	5 - 1"		

DIMENSIONS (X = SHUT-OFF VALVE CONFIGURATION)

MODEL NO. PART NO. SIZE	RP40S14 40 201 TXS 6 MM.	RP40S38 40 202 TXS 3/8"	RP40S38 40 202 TXS 10 MM.	RP40S12 40 203 TXS 1/2"	RP40S12 40 203 TXS 12 MM.	RP40S34 40 204 TXS 3/4"	RP40S34 40 204 TXS 20 MM.	RP40S1 40 205 TXS 1"	RP40S1 40 205 TXS 25 MM.
A	267	10-1/2	267	10-1/2	267	13-1/2	343	15-1/4	387
B	146	5-3/4	146	5-3/4	146	7-15/16	202	7-15/16	202
C	175	6-7/8	175	6-7/8	175	9	229	9	229
D	68	2-5/8	68	2-5/8	68	4-1/16	103	4-1/16	103
E	81	3-3/16	81	3-3/16	81	4-3/8	111	4-3/8	111
F	95	3-3/4	95	3-3/4	95	5-1/8	130	5-1/8	130
Test Cocks	1/8 x 1/4 NPT	1/8 x 1/4 NPT	1/8 x 1/4 NPT	1/8 x 1/4 NPT	1/8 x 1/4 NPT	1/8 x 1/4 NPT	1/8 x 1/4 NPT	1/8 x 1/4 NPT	1/8 x 1/4 NPT
WEIGHTS	KG.	LB.	KG.	LB.	KG.	LB.	KG.	LB.	KG.
Net Wt. (w/o Ball Valves)	2.0	4.3	2.0	4.1	1.9	8.1	3.8	8.1	3.7
Net Wt. (with Ball Valves)	2.5	5.5	2.5	5.4	2.4	10.8	4.9	11	5.0
Shpg. Wt. (w/o Ball Valves)	2.4	5.1	2.3	5	2.3	9.8	4.4	9.6	4.3
Shpg. Wt. (with Ball Valves)	2.9	6.4	2.9	6.3	2.8	12.3	5.6	12.8	5.8

BACKFLOW PREVENTION

RPDA2 / RPDA2LF 4A SERIES

BRONZE REDUCED PRESSURE DETECTOR BACKFLOW PREVENTER ASSEMBLY



The Apollo® Model RPDA24A or RPDA2LF4A Lead Free* 1-1/2" - 2" Reduced Pressure Detector Assembly consists of a mainline reduced pressure principle backflow preventer (RP) with a Type 2 bypass consisting of a single check (SCV) and meter bypassing the mainline second check to prevent backflow while accurately measuring all flows up to 2 gpm while the mainline 2nd check remains closed. The pressure drop across the assembly shall be documented by independent approval agencies. The assembly shall prevent contamination of the potable water supply due to back-siphonage or backpressure from substances that are health and non-health hazards. This Made in America assembly features Apollo® UL® Listed, slow-close, full open port, gear operated ball valves with integral tamper switches and carries the five-year Apollo® factory warranty.

FEATURES

- Low Pressure Loss Documented By Independent Approval Agencies
- Easily Removable Modular Check Valve Cartridges
- Captured Stainless Steel Springs
- Apollo® UL® Listed, Slow-Close, Full Open Port, Gear Operated Ball Valves with Integral Tamper Switches
- Top-Mounted Test Cocks for Easy Testing
- No Special Tools Required
- Chloramine-Resistant Elastomers
- **Designed, Cast, Machined, Assembled and Tested in the USA**
- Short Lay-Length for Small Spaces
- Pre-Wired Tamper (Supervisory) Switches

PERFORMANCE RATING

- Maximum Working Pressure: 175 psi
- Temperature Range: 33° to 140°F
- Hydrostatic Test Pressure: 350 psi

STANDARD MATERIALS LIST

BODY, CAPS, BALL VALVE SHUTOFFS, TEST COCKS	Bronze C84400 or C89836 or C87800 (Lead Free*)
CHECK VALVE CARTRIDGES	Glass-Filled PPO
SPRINGS	300 Series Stainless Steel
SEAT DISCS	Chloramine-Resistant Silicone
O-RINGS	Chloramine-Resistant EPDM

DIMENSIONS

SEE PAGE 61 FOR FLOW CURVES

SIZE (IN.)	DIMENSIONS (IN.)				WT. (LB.)
	A	B	C	D	
1-1/2"	22-1/4	2-5/8	9-3/4	10-1/2	39.4
2"	23-3/4	2-5/8	10	12-3/8	51.4

APPROVALS

- ASSE 1047 (Horizontal)
- UL Classified (Horizontal)
- C-UL Classified (Horizontal)
- Approved by the Foundation for Cross-Connection Control and Hydraulic Research at the University of Southern California. (Horizontal)
- NSF/ANSI 61 Water Quality (4ALF only)
- NSF/ANSI 372 Lead Free (4ALF only)

PART NUMBER MATRIX

4A X	7 X	X	X 2ST
	BYPASS SIDE	SIZE	METER OPTION
4A - STANDARD	2 - BYPASS LINE ON RIGHT SIDE (STANDARD - AS SHOWN)	7 - 1-1/2"	C - CUBIC FEET/MIN
4ALF - LEAD FREE	4 - BYPASS LINE ON LEFT SIDE	8 - 2"	E - GPM G - NO METER

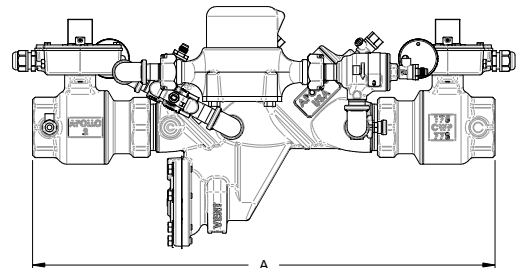
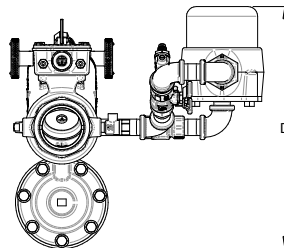
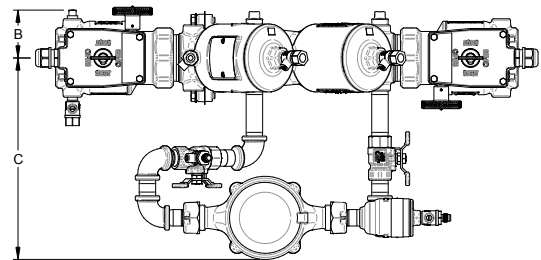

BACKFLOW PREVENTION

PVB 4A / PVBLF 4A SERIES

FREEZE RESISTANT PRESSURE VACUUM BREAKER BACKFLOW PREVENTER

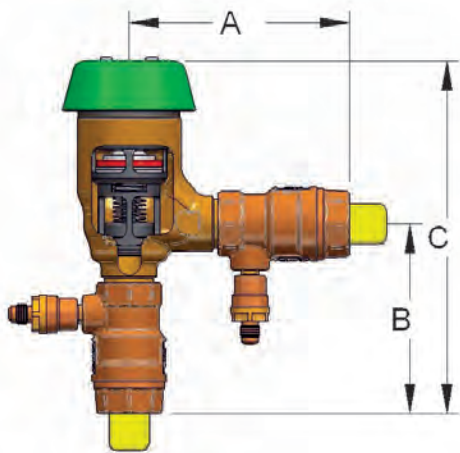

The Apollo® Model PVB 4A or PVBLF 4A Pressure Vacuum Breakers are designed to prevent contamination of potable water due to back-siphonage. An integral relief valve serves to reduce the possibility of damage due to intermittent freezing conditions. The modular check valve cartridge has a replaceable seat and a reversible silicone seat disc. Ball valves with stainless steel handles and nuts are standard.

FEATURES

- Modular Captured Spring Cartridge Check Valve
- Low Pressure Loss
- Easy Maintenance
- Built-In Freeze Resistant Relief Valve
- Compact Yet Easy to Maintain
- Ball Valves w/SS Handles & Nuts Standard
- Testcocks Located for Easy Draining
- Threaded Testcock Protectors
- Corrosion Resistant
- 5 Year Warranty
- No Special Tools Required
- Lead Free Option (3/4" - 1")
- Unique Canopy Detachment

PERFORMANCE RATING

- Maximum Operating Pressure: 150 psi
- Design Pressure: 300 psi
- Temperature Range: 33° to 140°F

APPROVALS

- ASSE 1020
- Approved by the Foundation for Cross-Connection Control and Hydraulic Research at the University of Southern California (1/2" - 2" Non Lead Free Only)
- CSA B64.1.2
- NSF/ANSI 372 Lead Free (4ALF only)

STANDARD MATERIALS LIST

BODY	Bronze (C84400/LF C89836)
BALL VALVES, TESTCOCKS	Bronze (C84800/LF C87800)
CANOPY	UV Resistant ABS
BONNET	Glass-Filled PPO
CHECK VALVE CARTRIDGE	Glass-Filled PPO
SPRINGS	Stainless Steel
SEAT DISCS	Chloramine-Resistant Silicone
FLOAT	Glass-Filled Polypropylene
O-RINGS	Chloramine-Resistant EPDM
BALL VALVE HANDLES	Stainless Steel

Contact local water authorities for installation/service requirements.

DIMENSIONS

PART NO.	MODEL NO.	DIMENSIONS (IN.) (MM)				WEIGHT	
		SIZE	A	B	C	LB.	KG.
4A-503-A2	PVB4A12	1/2" (15)	4-1/2 (114)	3-3/4 (95)	7-1/4 (184)	2.9	1.3
4A-504-A2	PVB4A34	3/4" (20)	4-3/4 (121)	4-1/8 (105)	7-5/8 (194)	3.0	1.4
4A-505-A2	PVB4A1	1" (25)	5-3/8 (135)	4-5/8 (194)	8-3/8 (211)	4.2	1.9
4A-506-A2	PVB4A114	1-1/4" (32)	7 (178)	5-1/4 (133)	9-7/8 (250)	4.4	2.0
4A-507-A2	PVB4A112	1-1/2" (40)	7-1/4 (184)	5-5/8 (143)	10-1/8 (257)	7.3	3.3
4A-508-A2	PVB4A2	2" (50)	8-1/2 (216)	6-3/8 (161)	11-1/2 (292)	8.9	4.0

PART NUMBER MATRIX

4A [X]	50 X	A X	X
	SIZE	SHUT-OFF VALVES	OPTIONS (CAN BE COMBINED)
4A - STANDARD	3 - 1/2"	2 - W/ BALL VALVES (STANDARD)	F - SAE THREADED TEST COCKS (STANDARD 1/2", 3/4", 1")
4ALF - LEAD FREE (3/4" - 1")	4 - 3/4"	4 - W/ UNION BALL VALVES	LL - LOCKING LEVER HANDLES (3/4" - 2")
	5 - 1"	(3/4" AND 1" ONLY)	
	6 - 1-1/4"		
	7 - 1-1/2"		
	8 - 2"		

SVB 4A / SVBLF 4A SERIES

SPILL RESISTANT VACUUM BREAKER BACKFLOW PREVENTER

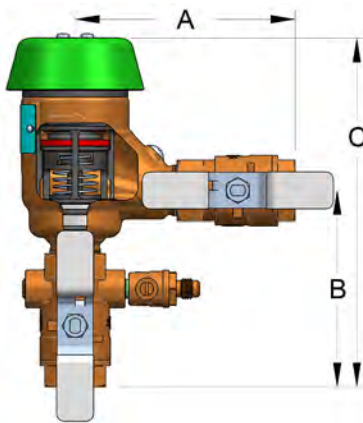

The Apollo® Series SVB 4A or SVBLF 4A Spill Resistant Vacuum Breaker is designed to prevent contamination of the potable water supply due to back-siphonage. The SVB is ideally suited for continuous pressure, indoor applications where water spillage is undesirable. The device has a straight through flow path for minimal head loss. All components are easily accessible for easy repair and maintenance. All components are made of corrosion resistant materials for years of reliable service. Should be installed 12" above all downstream piping.

FEATURES

- Modular Captured Spring Check Valve
- Shut-Off Valves w/ Stainless Steel Handles and Nuts
- Threaded Testcock Protectors
- Designed For Easy Maintenance
- Lead-Free Options
- Low Head Loss
- Corrosion Resistant
- 5 Year Warranty
- Unique Canopy Detachment
- No Special Tools Required
- **Designed, Manufactured, Assembled and Tested in the USA**

PERFORMANCE RATING

- Maximum Operating Pressure: 150 psi
- Temperature Range: 33° to 180°F

APPROVALS

- ASSE 1056
- NSF/ANSI 372 Lead Free (4ALF only)

STANDARD MATERIALS LIST

BODY	Bronze C84400 or C89836 Lead Free*
BALL VALVES, TEST COCKS	Bronze C84400 or C87800 Lead Free*
CANOPY	UV-Resistant ABS
BONNET	Glass-Filled PPO
CHECK VALVE CARTRIDGE	Glass-Filled PPO
SPRINGS	Stainless Steel
SEAT DISCS	Chloramine-resistant Silicone
FLOAT	Glass-Filled PPO
O-RINGS	Chloramine-resistant EPDM

DIMENSIONS

PART NO.	LEAD FREE PART NO.	MODEL NO.	LEAD FREE MODEL NO.	DIMENSIONS (IN.) (MM)				WEIGHT	
				SIZE	A	B	C	LB.	KG.
4A-904-A2F	4ALF-904-A2F	SVB4A34	SVBLF4A34	3/4" (20)	4-1/2 (121)	4 (105)	7-1/4 (194)	3.0	1.4
4A-905-A2F	4ALF-905-A2F	SVB4A1	SVBLF4A1	1" (25)	5-3/8 (135)	4-3/4 (194)	8-1/8 (211)	4.2	1.9

PART NUMBER MATRIX

4A [XX]	90 X	XX	X
	SIZE	SHUT-OFF VALVES	
4A - NON-LEAD FREE	4 - 3/4"	A2 - W/BALL VALVES (STANDARD)	F - SAE THREADED TEST COCKS (STANDARD)
4ALF - LEAD FREE*	5 - 1"	A4 - W/UNION END BALL VALVES	LL - LOCKING LEVER HANDLES

BACKFLOW PREVENTION

DCLF 4A SERIES

DOUBLE CHECK VALVE BACKFLOW PREVENTER ASSEMBLY

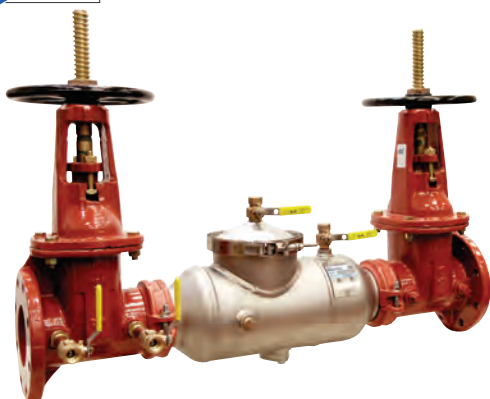

The Apollo® Model DCLF 4A Double Check Valves are designed to prevent contamination of the potable water supply due to back-siphonage or backpressure from substances that are objectionable, but non-health hazards. The TriForce™ center stem guided check valves feature replaceable and reversible silicone seat discs. The body is domestic stainless steel from 2-1/2"-8" and FDA epoxy coated ductile iron in the 10" and 12". Available with a wide variety of shutoff valve options.

OPERATION

During normal flow conditions, the two check valves are held off their seats, supplying water downstream. Each check valve is designed to maintain a minimum of 1 psi across the valve during normal operation. Should the downstream pressure increase to within 1 psi of supply pressure, both check valves will close to prevent a backflow condition.

FEATURES

- Domestic Stainless Steel Body: 2-1/2"-8"
- FDA Epoxy coated Ductile Iron body: 10" & 12"
- Easy Maintenance: No Special Tools Required
- Snap-in Check Retainers: 2-1/2"-6"
- Bolted-in Checks: 8"-12"
- Low Pressure Loss as Documented by an Independent Approval Laboratory
- Center Stem Guided TriForce™ Check Valves
- Approved for Horizontal and Vertical Up Flow
- Chloramine-Resistant Elastomers
- Lead Free Standard
- US Patent Nos.: 6,443,184; 7,025,085; 7,533,699
- **Designed, Fabricated, Assembled and Tested in the USA**
- 5 Year Warranty

APPROVALS

- ASSE 1015
- CSA B64.5
- Approved by the Foundation for Cross-Connection Control and Hydraulic Research at the University of Southern California (2-1/2" - 8")
- AWWA C-510
- IAPMO
- UL, ULC Classified
- FM Approved
- NSF/ANSI 372 Lead Free

PERFORMANCE RATING

- Maximum Working Pressure: 175 psi
- Temperature Range: 33° to 140°F, 180°F Intermittent

STANDARD MATERIALS LIST

BODY (2-1/2" - 8")	304 Stainless Steel
BODY (10" & 12")	FDA Epoxy Coated Ductile Iron
COVERS (2-1/2" - 6")	Glass Filled PPO/SS
COVERS (8")	304 Stainless Steel
COVERS (10" & 12")	FDA Epoxy Coated Ductile Iron
CHECK VALVES	Bronze/Glass-Filled PPO/SS
SPRINGS	Stainless Steel
SEAT DISCS	Chloramine-Resistant Silicone

PART NUMBER MATRIX

4ALF	1X	X	XX	XX
	Y-STRAINER	SIZE	SHUT-OFF VALVES (INLET X OUTLET)	OPTIONS
4ALF - LEAD FREE STANDARD	0 - STANDARD 1 - W/Y-STRAINER (SHIPPED LOOSE)	9 - 2-1/2" 0 - 3" A - 4" C - 6" E - 8" G - 10" H - 12"	01 - LESS SHUT-OFF VALVES 02 - NRS FLANGE X NRS FLANGE 03 - OS&Y FLANGE X OS&Y FLANGE 04 - OS&Y FLANGE X MONITORED (MON.) BUTTERFLY VALVE GROOVE' 06 - OS&Y FLANGE X POST INDICATOR FLANGE** 07 - OS&Y FLANGE X OS&Y GROOVE 08 - OS&Y GROOVE X OS&Y GROOVE 09 - MON. BUTTERFLY VALVE GROOVE X MON. BUTTERFLY VALVE GROOVE' 10 - OS&Y FLANGE X POST INDICATOR GROOVE** 11 - NRS GROOVE X NRS GROOVE 12 - NRS FLANGE X NRS GROOVE 13 - POST INDICATOR FLANGE X MON. BUTTERFLY VALVE GROOVE' 14 - POST INDICATOR FLANGE X POST INDICATOR FLANGE 16 - MON BUTTERFLY VALVE GROOVE X POST INDICATOR FLANGE' 17 - POST INDICATOR FLANGE X OS&Y GROOVE 18 - OS&Y GROOVE X POST INDICATOR GROOVE 19 - MON. BUTTERFLY VALVE GROOVE X POST INDICATOR GROOVE 20 - POST INDICATOR FLANGE X OS&Y FLANGE 21 - POST INDICATOR GROOVE X OS&Y GROOVE 22 - POST INDICATOR GROOVE X MON. BUTTERFLY VALVE GROOVE 23 - MON. BUTTERFLY VALVE GROOVE X OS&Y FLANGE	D - DOMESTIC ASSEMBLY R1 - RETROFIT* R2 - RETROFIT* R3 - RETROFIT* *CUSTOM LENGTH RETROFIT ORDERS MUST BE ACCOMPANIED WITH SIGNED FROM #OFBFRETRO WITH EXACT LENGTH REQUIRED.
EXAMPLE: 4ALF 10A 03 = 4" size Lead Free Double Check Valve Assembly with OS&Y flanged inlet x OS&Y flanged outlet shut-off valves (shown above)				

BACKFLOW PREVENTION

DC 4SGLF / 4SG / 4S SERIES

DOUBLE CHECK VALVE BACKFLOW PREVENTER ASSEMBLY



The Apollo® DC 4SGLF /4SG / 4S Series Double Check Valve is designed to prevent contamination of the potable water supply due to back-siphonage or backpressure from substances that are non-health hazards. The modular check valves have replaceable seats and reversible EPDM seat discs. Grooved connections on an epoxy-coated ductile iron body allow for easy connection to butterfly valves or gate valves (2-1/2" - 8"), flanged (10" only).

FEATURES

- Lightweight
- Short Lay Length
- Low Pressure Loss
- Modular Check Valves
- Individual Access to Check Valves
- Reversible/Replaceable Seat Discs
- Approved for Vertical (Up) and Horizontal Installations
- Gate Valves Epoxy Coated (FDA)
- Lead-Free (2-1/2" - 6" only)
- Corrosion Resistant Epoxy-Coated Ductile Iron Body
- US Patents Nos.: 5,711,341 and 6,343,618
- 5 Year Warranty
- **Assembled and Tested in the USA**

APPROVALS

- ASSE 1015
- CSA
- Approved by the Foundation for Cross-Connection Control and Hydraulic Research at the University of Southern California (2-1/2"-6" Lead Free / 8" & 10" Non-Lead Free Only)
- AWWA C-510
- UL Classified
- FM Approved
- NSF/ANSI 372 Lead Free (4SGLF only)

PERFORMANCE RATING

- Maximum Working Pressure: 175 psi
- Temperature Range: 33°F - 140°F
- Hydrostatic Test Pressure: 350 psi

STANDARD MATERIALS LIST

BODY	FDA Epoxy Coated Ductile Iron
COVERS (2-1/2" - 6")	FDA Epoxy Coated Steel
COVERS (8" & 10")	FDA Epoxy Coated Ductile Iron
CHECK VALVES (2-1/2" - 6")	Glass-Filled PPO
CHECK VALVES (8" & 10")	Bronze (C84400/LF C89836)
SPRINGS	Stainless Steel
SEAT DISCS	Chloramine-Resistant EPDM
TEST COCK HANDLES	Stainless Steel

PART NUMBER MATRIX

4S XXX	1 X	X	XX	X
	Y-STRAINER	SIZE	SHUT-OFF VALVES (INLET X OUTLET)	OPTIONS
4SGLF - LEAD FREE (2-1/2"-6" ONLY)	0 - NONE (STANDARD) 1 - WITH Y-STRAINER (FLANGED ONLY, SHIPPED LOOSE)	9 - 2-1/2" 0 - 3" A - 4" C - 6" E - 8" G - 10"*	01 - LESS SHUT-OFF VALVES (GROOVED-END BODY) 02 - NRS FLANGE X NRS FLANGE 03 - OS&Y FLANGE X OS&Y FLANGE 04 - OS&Y FLANGE X MONITORED BUTTERFLY VALVE GROOVE 06 - OS&Y FLANGE X FLANGE POST INDICATOR 07 - OS&Y FLANGE X OS&Y GROOVE 08 - OS&Y GROOVE X OS&Y GROOVE 09 - MON. BUTTERFLY VALVE GROOVE X MON. BUTTERFLY VALVE GROOVE 10 - OS&Y FLANGE X GROOVE POST INDICATOR	D - DOMESTIC ASSEMBLY
4SG - 8" ONLY				
4S - 10" ONLY				
EXAMPLE: 4SGLF 10A 07 = 4" size lead free double check valve assembly with OS&Y flanged inlet x OS&Y grooved outlet shut-off valves				

*10" body is flanged internal connections only (Model 4S)

BACKFLOW PREVENTION

DCDALF 4An / DCDA2LF 4An SERIES

n STYLE DOUBLE CHECK DETECTOR BACKFLOW PREVENTER ASSEMBLY



n FLOW



OPTIONAL VALVE SETTER



TRIFORCE™ CHECK



The Apollo® Model DCLF 4An Double Check Valves are designed to prevent contamination of the potable water supply due to back-siphonage or backpressure from substances that are objectionable, but non-health hazards. The TriForce™ center stem guided check valves feature replaceable and reversible silicone seat discs. The by-pass assembly serves to measure water use of up to 2 GPM. The normally vertical up/vertical down oriented body incorporates an internal swivel connection providing the ability to pivot the second check. The grooved connections on the bodies from 2-1/2" to 10" allow for easy connection to butterfly or gate shut-off valves. The 12" DCDA 4An has flanged connections for gate shut-off valves.

Available in both Type 1 and Type 2 bypass configurations. The Type 2 bypass uses the first check of the mainline assembly as the first check of the bypass. The second check of the bypass is a single check valve with a model number and serial number for test recording. This arrangement complies with the National Backflow Standards. The arrangement provides the same level of protection as the Type 1 bypass and the testing procedure is the same.

FEATURES

- Domestic Stainless Steel Body: 2-1/2"-8"
- FDA Epoxy Coated Ductile Iron Body: 10" & 12"
- Easy Maintenance: No Special Tools Required
- Drop-In Check Retainers: 2-1/2"-6"
- Bolted-In Checks: 8"-12"
- Low Pressure Loss as Documented by an Independent Approval Laboratory
- Center Stem Guided TriForce™ Check Valves
- 5 Year Warranty
- Small Installation Space Required - Small Footprint
- Chloramine-Resistant Elastomers
- Lead Free Standard
- Optional Valve Setters Eliminate Need for Thrust Blocks Below Grade
- US Patent Nos.: 6,443,184; 7,025,085; 7,533,699
- **Designed, Fabricated, Assembled and Tested in the USA**
- Optional Mounting of Bypass on either Side for Ease of Installation

APPROVALS

- ASSE 1048 (with Meter)
- UL, ULC Classified
- CSA B64.5
- Approved by the Foundation for Cross-Connection Control and Hydraulic Research at the University of Southern California (2-1/2" - 8" Type 1 Bypass)
- FM Approved
- NSF/ANSI 372 Lead Free

PERFORMANCE RATING

- Maximum Working Pressure: 175 psi
- Temperature Range: 33° to 140°F, 180°F intermittent

STANDARD MATERIALS LIST

BODY (2-1/2" - 8")	304 Stainless Steel
BODY (10" & 12")	FDA Epoxy Coated Ductile Iron
COVERS (2-1/2" - 6")	Glass Filled PPO/SS
COVERS (8")	304 Stainless Steel
COVERS (10" & 12")	FDA Epoxy Coated Ductile Iron
CHECK VALVES	Bronze/Glass-Filled PPO/SS
SPRINGS	Stainless Steel
SEAT DISCS	Chloramine-Resistant Silicone

PART NUMBER MATRIX

4ANLF	1X	X	XX	X
	Y-STRAINER	SIZE	SHUT-OFF VALVES (INLET X OUTLET)	OPTIONS
4ANLF - LEAD FREE STANDARD	0 - STANDARD 1 - W/ Y-STRAINER (SHIPPED LOOSE)	9 - 2-1/2" 0 - 3" A - 4" C - 6" E - 8" G - 10" H - 12"	01 - LESS SHUT-OFF VALVES 02 - NRS FLANGE X NRS FLANGE 03 - OS&Y FLANGE X OS&Y FLANGE 04 - OS&Y FLANGE X MONITORED (MON.) BUTTERFLY VALVE GROOVE 06 - OS&Y FLANGE X POST INDICATOR FLANGE 07 - OS&Y FLANGE X OS&Y GROOVE 08 - OS&Y GROOVE X OS&Y GROOVE 09 - MON. BUTTERFLY VALVE GROOVE X MON. BUTTERFLY VALVE GROOVE 10 - OS&Y FLANGE X POST INDICATOR GROOVE 11 - NRS GROOVE X NRS GROOVE 12 - NRS FLANGE X NRS GROOVE 13 - POST INDICATOR FLANGE X MON. BUTTERFLY VALVE GROOVE 14 - POST INDICATOR FLANGE X POST INDICATOR FLANGE 16 - MON BUTTERFLY VALVE GROOVE X POST INDICATOR FLANGE 17 - POST INDICATOR FLANGE X OS&Y GROOVE 18 - OS&Y GROOVE X POST INDICATOR GROOVE 19 - MON. BUTTERFLY VALVE GROOVE X POST INDICATOR GROOVE 20 - POST INDICATOR FLANGE X OS&Y FLANGE 21 - POST INDICATOR GROOVE X OS&Y GROOVE 22 - POST INDICATOR GROOVE X MON. BUTTERFLY VALVE GROOVE 23 - MON. BUTTERFLY VALVE GROOVE X OS&Y FLANGE	D - DOMESTIC ASSEMBLY
EXAMPLE: 4ANLF 10A 03 = 4" size lead free double check valve assembly with OS&Y flanged inlet x OS&Y flanged outlet shut-off valves (shown above)				

DCDALF 4A / DCDA2LF 4A SERIES

DOUBLE CHECK DETECTOR BACKFLOW PREVENTER ASSEMBLY



TYPE 1 BYPASS



TYPE 2 BYPASS

TRIFORCE™ CHECK



The Apollo® Model DCDALF 4A / DCDA2LF 4A Double Check Detector Assembly is designed to prevent contamination of the potable water supply due to back-siphonage or backpressure from substances that are objectionable, but non-health hazards. The TriForce™ center stem guided check valves feature replaceable and reversible silicone seat discs. The bypass assembly serves to measure accurate water use of up to 2 GPM. Available in a wide variety of shut-off options.

Available in both Type 1 and Type 2 bypass configurations. The Type 2 bypass uses the first check of the mainline assembly as the first check of the bypass. The second check of the bypass is a single check valve with a model number and serial number for test recording. This arrangement complies with the National Backflow Standards. The arrangement provides the same level of protection as the Type 1 bypass and the testing procedure is the same.

FEATURES

- Domestic Stainless Steel Body: 2-1/2"-8"
- FDA Epoxy Coated Ductile Iron Body: 10" & 12"
- Easy Maintenance: No Special Tools Required
- Drop-In Check Retainers: 2-1/2"-6"
- Bolted-In Checks: 8"-12"
- Low Pressure Loss as Documented by an Independent Approval Laboratory
- Center Stem Guided TriForce™ Check Valves
- Approved for Horizontal and Vertical Up Flow
- Chloramine-Resistant Elastomers
- Lead-Free Standard
- US Patent Nos.: 6,443,184; 7,025,085; 7,533,699
- **Designed, Fabricated, Assembled and Tested in the USA**
- 5 Year Warranty
- Optional Mounting of Bypass on Either Side for Ease of Installation

APPROVALS

- ASSE 1048 (With Meter)
- UL, ULC Classified
- FM Approved
- CSA B64.5
- Approved by the Foundation for Cross-Connection Control and Hydraulic Research at the University Of Southern California (2-1/2" - 8" Type 1 & 2 Bypass)
- NSF/ANSI 372 Lead Free

PERFORMANCE RATING

- Maximum Working Pressure: 175 Psi
- Temperature Range: 33° to 140°F, 180°F Intermittent

PART NUMBER MATRIX

4ALF	6 X	X	X	XX	X
	BYPASS SUB-ASSEMBLY OPTIONS	SIZE	METER OPTION	SHUT-OFF VALVES (INLET X OUTLET)	OPTIONS
4ALF - LEAD FREE	0 - TYPE 1 W/ 1/2" DOUBLE CHECK	9 - 2-1/2"	C - CUBIC FEET/MIN	01 - LESS SHUT-OFF VALVES	D - DOMESTIC ASSEMBLY
	2 - TYPE 2 W/1/2" SINGLE CHECK (STD)	0 - 3"	E - GALLONS/MIN	03 - OS&Y FLANGE X OS&Y FLANGE	
	3 - TYPE 1 W/ BYPASS ON LEFT*	A - 4"	G - LESS METER	04 - OS&Y FLANGE X MONITORED (MON.) BUTTERFLY VALVE GROOVE ¹	R1 - RETROFIT*
	4 - TYPE 2 W/ BYPASS ON LEFT*	C - 6"		06 - OS&Y FLANGE X POST INDICATOR FLANGE	R2 - RETROFIT*
		E - 8"		07 - OS&Y FLANGE X OS&Y GROOVE	R3 - RETROFIT*
		G - 10"		08 - OS&Y GROOVE X OS&Y GROOVE	
		H - 12"		09 - MON. BUTTERFLY VALVE GROOVE X MON. BUTTERFLY VALVE GROOVE ¹	
				10 - OS&Y FLANGE X POST INDICATOR GROOVE	*CUSTOM LENGTH RETROFIT ORDERS MUST BE ACCOMPANIED WITH SIGNED FROM #OFBFRETRO WITH EXACT LENGTH REQUIRED.
				13 - POST INDICATOR FLANGE X MON. BUTTERFLY VALVE GROOVE ¹	
				14 - POST INDICATOR FLANGE X POST INDICATOR FLANGE	
				16 - MON BUTTERFLY VALVE GROOVE X POST INDICATOR FLANGE ¹	
				17 - POST INDICATOR FLANGE X OS&Y GROOVE	
				18 - OS&Y GROOVE X POST INDICATOR GROOVE	
				19 - MON. BUTTERFLY VALVE GROOVE X POST INDICATOR GROOVE	
				20 - POST INDICATOR FLANGE X OS&Y FLANGE	
				21 - POST INDICATOR GROOVE X OS&Y GROOVE	
				22 - POST INDICATOR GROOVE X MON. BUTTERFLY VALVE GROOVE ¹	
				23 - MON. BUTTERFLY VALVE GROOVE X OS&Y FLANGE	

EXAMPLE:
4ALF 60A E3 = 4" size lead free double check detector assembly with OS&Y flanged inlet x OS&Y flanged outlet shut-off valves w/ meter in gallons.

*Orientation of bypass looking downstream.
Standard is right hand side. Left hand is on opposite side
¹Butterfly valves not available in 12" size.

BACKFLOW PREVENTION

DCDA 4SG SERIES

DOUBLE CHECK DETECTOR BACKFLOW PREVENTER ASSEMBLY

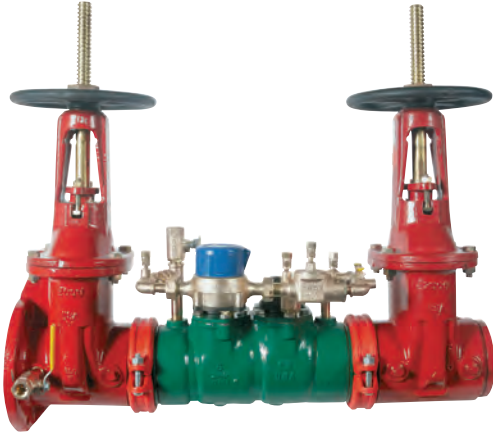

The Apollo® DCDA 4SG Series Double Check Detector Assembly is designed to prevent contamination of the potable water supply due to back-siphonage or backpressure from substances that are non-health hazards. The device consists of a mainline double check valve with resilient seated shut-off valves. The by-pass serves to measure water use of up to 3 gpm. Grooved connections on an epoxy-coated ductile iron body allow for easy connection to butterfly valves or gate valves. (2-1/2" - 8")

FEATURES

- Lightweight
- Short Lay Length
- Low Pressure Loss
- Modular Check Valves
- Individual Access to Check Calves
- Reversible/Replaceable Seat Discs
- Approved for Vertical and Horizontal Installations
- Gate Valves Epoxy Coated (FDA)
- Corrosion Resistant FDA Epoxy Coated Ductile Iron Body
- US Patents Nos.: 5,711,341 and 6,343,618
- 5 Year Warranty
- **Assembled and Tested in the USA**

APPROVALS

- UL Classified
- FM Approved
- Approved by the Foundation for Cross-Connection Control and Hydraulic Research at the University of Southern California (2-1/2" - 10" Non Lead Free Only)
- ASSE 1048 (with Meter)
- CSA

PERFORMANCE RATING

- Maximum Working Pressure: 175 psi
- Temperature Range: 33°F - 140°F
- Hydrostatic Test Pressure: 350 psi

STANDARD MATERIALS LIST

BODY (MAINLINE)	FDA Epoxy Coated Ductile Iron
BYPASS DC	Bronze (C8440/LF C89836)
COVERS (2-1/2" - 6")	FDA Epoxy Coated Steel
COVERS (8")	FDA Epoxy Coated Ductile Iron
CHECK VALVES (2-1/2" - 6")	Glass-Filled PPO
CHECK VALVES (8" - 10")	Bronze (C8440)
SPRINGS	Stainless Steel
SEAT DISCS	Chloramine-Resistant EPDM
TEST COCK HANDLES	Stainless Steel

PART NUMBER MATRIX

4S X	60 X	X	XX	X
	SIZE	METER OPTION	SHUT-OFF VALVES (INLET X OUTLET)	OPTION
4SG - STANDARD (2-1/2"-8" ONLY)	9 - 2-1/2"	C - CUBIC FEET/MIN	03 - OS&Y FLANGE X OS&Y FLANGE	D - DOMESTIC ASSEMBLY
4S - 10" ONLY	0 - 3"	E - GALLONS/MIN	04 - OS&Y FLANGE X MONITORED BUTTERFLY VALVE GROOVE	
	A - 4"	G - LESS METER	06 - OS&Y FLANGE X FLANGE POST INDICATOR	
	C - 6"		07 - OS&Y FLANGE X OS&Y GROOVE	
	E - 8"		08 - OS&Y GROOVE X OS&Y GROOVE	
	G - 10**		09 - MON. BUTTERFLY VALVE GROOVE X MON. BUTTERFLY VALVE GROOVE	
			10 - OS&Y FLANGE X GROOVE POST INDICATOR	

*10" body is flanged internal connections only (Model 4S)

EXAMPLE:
4SG 60A E7 = 4" size double check detector assembly with meter in GPM and OS&Y flanged inlet x OS&Y grooved outlet shut-off valves

DCDALF 4AN SERIES
N STYLE DOUBLE CHECK DETECTOR BACKFLOW PREVENTER



TYPE 2 BYPASS (STANDARD)
SIZES 2-1/2"-12"



OPTIONAL VALVE SETTER



TRIFORCE™ CHECK



STANDARD MATERIALS LIST

BODY (2-1/2" - 8")	304 Stainless Steel
BODY (10" & 12")	FDA Epoxy Coated Ductile Iron
COVERS (2-1/2" - 6")	Glass Filled PPO/SS
COVERS (8")	304 Stainless Steel
COVERS (10" & 12")	FDA Epoxy Coated Ductile Iron
CHECK VALVES	Bronze/Glass-Filled PPO/SS
SPRINGS	Stainless Steel
SEAT DISCS	Chloramine-Resistant Silicone

The Apollo® Model DCLF 4An Double Check Valves are designed to prevent contamination of the potable water supply due to back-siphonage or backpressure from substances that are objectionable, but non-health hazards. The TriForce™ center stem guided check valves feature replaceable and reversible silicone seat discs. The by-pass assembly serves to measure water use of up to 2 GPM. The normally vertical up/vertical down oriented body incorporates an internal swivel connection providing the ability to pivot the second check. The grooved connections on the bodies from 2-1/2" to 10" allow for easy connection to butterfly or gate shut-off valves. The 12" DCDA 4An has flanged connections for gate shut-off valves.

The standard Type 2 bypass uses the first check of the mainline assembly as the first check of the bypass. The second check of the bypass is a single check valve with a model number and serial number for test recording. This arrangement complies with the National Backflow Standards. The arrangement provides the same level of protection as the Type 1 bypass and the testing procedure is the same.

FEATURES

- Domestic Stainless Steel Body: 2-1/2"-8"
- FDA Epoxy Coated Ductile Iron Body: 10" & 12"
- Easy Maintenance: No Special Tools Required
- Drop-In Check Retainers: 2-1/2"-6"
- Bolted-In Checks: 8"-12"
- Low Pressure Loss as Documented by an Independent Approval Laboratory
- Center Stem Guided TriForce™ Check Valves
- 5 Year Warranty
- Small Installation Space Required - Small Footprint
- Chloramine-Resistant Elastomers
- Lead Free Standard
- Optional Valve Setters Eliminate Need for Thrust Blocks Below Grade
- US Patent Nos.: 6,443,184; 7,025,085; 7,533,699
- **Made in the USA (D Option)**
- Optional Mounting of Bypass on either Side for Ease of Installation

APPROVALS

- ASSE 1048 (with Meter)
- UL, ULC Classified
- CSA B64.5
- Approved by the Foundation for Cross-Connection Control and Hydraulic Research at the University of Southern California (2-1/2" - 8" Type 1 Bypass)
- FM Approved
- NSF/ANSI 372 Lead Free (2-1/2" - 12")

PERFORMANCE RATING

- Maximum Working Pressure: 175 psi
- Temperature Range: 33° to 140°F, 180°F intermittent

PART NUMBER MATRIX

4ANLF	6 X	X	X	X [X]	X
	BYPASS SUB-ASSEMBLY OPTIONS	SIZE	METER OPTION	SHUT-OFF VALVES (INLET X OUTLET)	OPTIONS
4ANLF - LEAD FREE	0 - TYPE 1 W/ 1/2" DOUBLE CHECK	9 - 2-1/2"	C - CUBIC FEET/MIN	1 - LESS SHUT-OFF VALVES	D - DOMESTIC ASSEMBLY
	2 - TYPE 2 W/ 1/2" SINGLE CHECK (STD)	0 - 3"	E - GALLONS/MIN	3 - OS&Y FLANGE X OS&Y FLANGE	
	3 - TYPE 1 W/ BYPASS ON LEFT*	A - 4"	G - LESS METER	4 - OS&Y FLANGE X MONITORED (MON.) BUTTERFLY VALVE GROOVE†	
	4 - TYPE 2 W/ BYPASS ON LEFT*	C - 6"		6 - OS&Y FLANGE X POST INDICATOR FLANGE	
		E - 8"		7 - OS&Y FLANGE X OS&Y GROOVE	
		G - 10"		8 - OS&Y GROOVE X OS&Y GROOVE	
		H - 12"		9 - MON. BUTTERFLY VALVE GROOVE X MON. BUTTERFLY VALVE GROOVE†	
				10 - OS&Y FLANGE X POST INDICATOR GROOVE	
				13 - POST INDICATOR FLANGE X MON. BUTTERFLY VALVE GROOVE†	
				14 - POST INDICATOR FLANGE X POST INDICATOR FLANGE	
				16 - MON BUTTERFLY VALVE GROOVE X POST INDICATOR FLANGE†	
				17 - POST INDICATOR FLANGE X OS&Y GROOVE	
				18 - OS&Y GROOVE X POST INDICATOR GROOVE	
				19 - MON. BUTTERFLY VALVE GROOVE X POST INDICATOR GROOVE	
				20 - POST INDICATOR FLANGE X OS&Y FLANGE	
				21 - POST INDICATOR GROOVE X OS&Y GROOVE	
				22 - POST INDICATOR GROOVE X MON. BUTTERFLY VALVE GROOVE†	
				23 - MON. BUTTERFLY VALVE GROOVE X OS&Y FLANGE	

EXAMPLE: 4ANLF 62A E7 = 4" size Lead Free Double Check Detector Assembly with OS&Y flanged inlet x OS&Y grooved outlet shut-off valves with Type 2 bypass w/ meter in GPM

*Orientation of bypass looking downstream. Standard is right hand side. Left hand is on opposite side
†Butterfly valves not available in 12" size.

BACKFLOW PREVENTION

RPLF 4A SERIES

REDUCED PRESSURE PRINCIPLE BACKFLOW PREVENTER ASSEMBLY

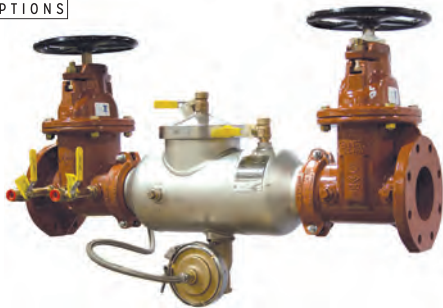

TRIFORCE™ CHECK



The Apollo® Model RPLF 4A Reduced Pressure Principle Backflow Preventers consist of two independently acting, TriForce™ center stem guided check valves with a differential pressure relief valve located between the check valves. The unit is designed to give maximum protection against backflow of health or non-health hazard fluids by either back-pressure or back-siphonage. The durable domestic stainless steel units (2-1/2"-8") and the FDA epoxy coated ductile iron units (10" and 12") are easily maintained in the line without any special tools. The TriForce™ check valves operate with a spring assist in the flowing condition to provide excellent flow rates which are documented by an independent laboratory.

OPERATION

During normal flow conditions, the two check valves are held off their seats, supplying water downstream. The relief valve is held shut by supply pressure acting through the sensing tube on the relief valve diaphragm. In the area between the check valves, called the zone, the pressure is maintained approximately 7 psi lower than supply pressure. Should a back-pressure or back-siphonage condition occur, the second check valve will seal, prohibiting the backflow of water. Should the second check become fouled, the pressure in the zone will increase causing the differential relief valve to open to atmosphere. This will maintain the pressure in the zone at least 2 psi lower than supply pressure.

FEATURES

- Domestic Stainless Steel Body: 2-1/2"-8"
- FDA Epoxy Coated Ductile Iron Body: 10" & 12"
- Easy Maintenance: No Special Tools Required
- Snap-In Check Retainers: 2-1/2"-6"
- Bolted-in Checks: 8"-12"
- Modular Captured Spring Relief Valve
- Low Pressure Loss as Documented by an Independent Approval Laboratory
- Center Stem Guided TriForce™ Check Valves
- Chloramine-Resistant Elastomers
- **Designed, Fabricated, Assembled and Tested in the USA**
- Lead Free Standard
- Optional Air Gap Drains
- 5 Year Warranty
- US Patent Nos.: 6,443,184; 7,025,085; 7,533,699

PERFORMANCE RATING

- Maximum Working Pressure: 175 psi
- Temperature Range: 33° to 140°F, 180°F Intermittent

APPROVALS

- Approved for Horizontal Flow
- ASSE 1013
- CSA B64.4
- AWWA C-511
- Approved by the Foundation for Cross-Connection Control and Hydraulic Research at the University of Southern California (2-1/2" - 8")
- UL, ULC Classified
- FM Approved
- NSF/ANSI 372 Lead Free

STANDARD MATERIALS LIST

BODY (2-1/2" - 8")	304 Stainless Steel
BODY (10" & 12")	FDA Epoxy Coated Ductile Iron
COVERS (2-1/2" - 6")	Glass Filled PPO/SS
COVERS (8")	304 Stainless Steel
COVERS (10" & 12")	FDA Epoxy Coated Ductile Iron
RELIEF VALVE	LF C89836
CHECK VALVES	Bronze/Glass-filled PPO/SS
SPRINGS	Stainless Steel
SEAT DISCS	Chloramine-Resistant Silicone

PART NUMBER MATRIX

4ALF	2 X	X	XX	XX
	Y-STRAINER	SIZE	SHUT-OFF VALVES	OPTIONS
4ALF - LEAD FREE STANDARD	0 - STANDARD	9 - 2-1/2"	01 - LESS SHUT-OFF VALVES	D - DOMESTIC ASSEMBLY
	1 - W/ Y-STRAINER (SHIPPED LOOSE)	0 - 3"	02 - NRS FLANGE X NRS FLANGE	R1 - RETROFIT*
		A - 4"	03 - OS&Y FLANGE X OS&Y FLANGE	R2 - RETROFIT*
		C - 6"	04 - OS&Y FLANGE X MONITORED (MON.) BUTTERFLY VALVE GROOVE ¹	R3 - RETROFIT*
		E - 8"	06 - OS&Y FLANGE X POST INDICATOR FLANGE	
		G - 10"	07 - OS&Y FLANGE X OS&Y GROOVE	*CUSTOM LENGTH RETROFIT ORDERS MUST BE ACCOMPANIED WITH SIGNED FROM #OFBFRETRO WITH EXACT LENGTH REQUIRED.
		H - 12"	08 - OS&Y GROOVE X OS&Y GROOVE	
			09 - MON. BUTTERFLY VALVE GROOVE X MON. BUTTERFLY VALVE GROOVE ¹	
			10 - OS&Y FLANGE X POST INDICATOR GROOVE	
			11 - NRS GROOVE X NRS GROOVE	
			12 - NRS FLANGE X NRS GROOVE	
			13 - POST INDICATOR FLANGE X MON. BUTTERFLY VALVE GROOVE ¹	
			14 - POST INDICATOR FLANGE X POST INDICATOR FLANGE	
			16 - MON BUTTERFLY VALVE GROOVE X POST INDICATOR FLANGE ¹	
			17 - POST INDICATOR FLANGE X OS&Y GROOVE	
			18 - OS&Y GROOVE X POST INDICATOR GROOVE	
			19 - MON. BUTTERFLY VALVE GROOVE X POST INDICATOR GROOVE	
			20 - POST INDICATOR FLANGE X OS&Y FLANGE	
			21 - POST INDICATOR GROOVE X OS&Y GROOVE	
			22 - POST INDICATOR GROOVE X MON. BUTTERFLY VALVE GROOVE ¹	
			23 - MON. BUTTERFLY VALVE GROOVE X OS&Y FLANGE	

EXAMPLE: 4ALF 20A 07 = 4" size lead free reduced pressure assembly with OS&Y flanged inlet x OS&Y grooved outlet shut-off valves.

¹ Butterfly valves not available in 12" size.

RPLF 4An SERIES

n STYLE REDUCED PRESSURE PRINCIPLE BACKFLOW PREVENTER ASSEMBLY



n FLOW



VERTICAL UP FLOW



OPTIONAL VALVE SETTER



TRIFORCE™ CHECK

The Apollo® RPLF 4An Reduced Pressure Principle Backflow Preventer consists of two independently acting, TriForce™ center stem guided check valves with a differential pressure relief valve located between the check valves. The unit is designed to give maximum protection against backflow of health or non-health hazardous fluids by either back-pressure or back-siphonage. The normally vertical up/vertical down oriented body incorporates an internal swivel connection providing the ability to pivot the second check 180° to a vertical up/vertical up flow. The durable domestic stainless steel units (2-1/2" to 8") and the FDA epoxy coated ductile iron units (10" and 12") are easily maintained in the line without any special tools. The TriForce™ check valves operate with a spring assist in the flowing condition to provide excellent flow rates which are documented by an independent laboratory.

OPERATION

During normal flow conditions, the two check valves are held off their seats, supplying water downstream. The relief valve is held shut by supply pressure acting through the sensing tube on the relief valve diaphragm. In the area between the check valves, called the zone, the pressure is maintained approximately 7 psi lower than supply pressure. Should a back-pressure or back-siphonage condition occur, the second check valve will seal, prohibiting the backflow of water. Should the second check become fouled, the pressure in the zone will increase causing the differential relief valve to open to atmosphere. This will maintain the pressure in the zone at least 2 psi lower than supply pressure.

FEATURES

- Domestic Stainless Steel Body: 2-1/2"-8"
- FDA Epoxy Coated ductile Iron Body: 10" & 12"
- Easy Maintenance: No Special Tools Required
- Drop-In Check Retainers: 2-1/2"-6"
- Bolted-In Checks: 8"-12"
- Low Pressure Loss as Documented by an Independent Approval Laboratory
- Center Stem Guided TriForce™ Check Valves
- Modular Captured Spring Relief Valve
- Optional Air Gap Drains
- Small Installation Space Required/Footprint
- Approved for n-Flow and Vertical Up Flow
- Chloramine-Resistant Elastomers
- Lead Free Standard
- Optional Valve Setters
- US Patent Nos.: 6,443,184; 7,025,085; 7,533,699
- **Designed, Fabricated, Assembled and Tested in the USA**
- 5 Year Warranty

PERFORMANCE RATING

- Maximum Working Pressure; 175 psi
- Temperature Range; 33° to 140°F, 180°F Intermittent

APPROVALS

- ASSE 1013
- CSA B64.4
- Approved by the Foundation for Cross-Connection Control and Hydraulic Research at the University of Southern California (2-1/2" - 8")
- AWWA C-511
- UL, ULC Classified
- FM Approved
- NSF/ANSI 372 Lead Free

STANDARD MATERIALS LIST

BODY (2-1/2" - 8")	304 Stainless Steel	RELIEF VALVE	Bronze (C84400/LF C89836)
BODY (10" & 12")	FDA Epoxy Coated Ductile Iron	CHECK VALVES	Bronze/Glass-Filled PPO/SS
COVERS (2-1/2" - 6")	Glass Filled PPO/SS	SPRINGS	Stainless Steel
COVERS (8")	304 Stainless Steel	SEAT DISCS	Chloramine-Resistant Silicone
COVERS (10" & 12")	FDA Epoxy Coated Ductile Iron		

PART NUMBER MATRIX

4ANLF	2 X	X	XX	X
	Y-STRAINER	SIZE	SHUT-OFF VALVES	OPTIONS
4ANLF - LEAD FREE	0 - STANDARD	9 - 2-1/2"	01 - LESS SHUT-OFF VALVES	D - DOMESTIC ASSEMBLY
	1 - W/ Y-STRAINER (SHIPPED LOOSE)	0 - 3"	02 - NRS FLANGE X NRS FLANGE	
		A - 4"	03 - OS&Y FLANGE X OS&Y FLANGE	
		C - 6"	04 - OS&Y FLANGE X MONITORED (MON.) BUTTERFLY VALVE GROOVE†	
		E - 8"	06 - OS&Y FLANGE X POST INDICATOR FLANGE	
		G - 10"	07 - OS&Y FLANGE X OS&Y GROOVE	
		H - 12"	08 - OS&Y GROOVE X OS&Y GROOVE	
			09 - MON. BUTTERFLY VALVE GROOVE X MON. BUTTERFLY VALVE GROOVE†	
			10 - OS&Y FLANGE X POST INDICATOR GROOVE	
			11 - NRS GROOVE X NRS GROOVE	
			12 - NRS FLANGE X NRS GROOVE	
			13 - POST INDICATOR FLANGE X MON. BUTTERFLY VALVE GROOVE†	
			14 - POST INDICATOR FLANGE X POST INDICATOR FLANGE	
			16 - MON BUTTERFLY VALVE GROOVE X POST INDICATOR FLANGE†	
			17 - POST INDICATOR FLANGE X OS&Y GROOVE	
			18 - OS&Y GROOVE X POST INDICATOR GROOVE	
			19 - MON. BUTTERFLY VALVE GROOVE X POST INDICATOR GROOVE	
			20 - POST INDICATOR FLANGE X OS&Y FLANGE	
			21 - POST INDICATOR GROOVE X OS&Y GROOVE	
			22 - POST INDICATOR GROOVE X MON. BUTTERFLY VALVE GROOVE†	
			23 - MON. BUTTERFLY VALVE GROOVE X OS&Y FLANGE	

EXAMPLE: 4A 215 A4LL = 4" size Reduced Pressure Assembly with OS&Y flanged inlet x OS&Y grooved outlet shut-off valves

EXAMPLE: 4AN 20A 03 = 4" size reduced pressure assembly with OS&Y flanged inlet x OS&Y flanged outlet shut-off valves

† Butterfly valves not available in 12" size.

RPDALF 4A / RPDA2LF SERIES

REDUCED PRESSURE DETECTOR BACKFLOW PREVENTER ASSEMBLY



TYPE 2 BYPASS (STANDARD)



TYPE 1 BYPASS SIZES 2-1/2"-12"

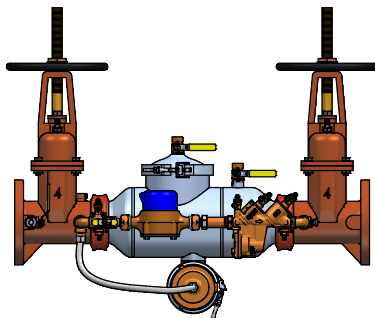

TRIFORCE™ CHECK



The Apollo® Model RPDALF 4A / RPDA2LF 4A Reduced Pressure Detector Assembly consists of two independently acting, TriForce™ center stem guided check valves with a differential pressure relief valve located between the check valves. The unit is designed to give maximum protection against backflow of health or non-health hazard fluids by either back-pressure or back-siphonage and at the same time detect leakage or unauthorized use of water from fire or automatic sprinkler systems. The durable domestic stainless steel units (2-1/2" to 8") and the FDA epoxy coated ductile iron units (10" and 12") are easily maintained in line without any special tools. The TriForce™ check valves operate with a spring assist in the flowing condition to provide low flow rates which are documented by an independent laboratory.

Available in both Type 1 and Type 2 bypass configurations. The Type 2 bypass uses the first check of the mainline assembly as the first check of the bypass. The second check of the bypass is a single check valve with a model number and serial number for test recording. This arrangement complies with the National Backflow Standards. The arrangement provides the same level of protection as the Type 1 bypass and the testing procedure is the same.

FEATURES

- Domestic Stainless Steel Body: 2-1/2"-8"
- FDA Epoxy Coated Ductile Iron Body: 10" & 12"
- Easy Maintenance: No Special Tools Required
- Snap-In Check Retainers: 2-1/2"-6"
- Bolted-In Checks: 8"-12"
- Low Pressure Loss as Documented by an Independent Approval Laboratory
- Center Stem Guided TriForce™ Check Valves
- Modular Captured Spring Relief Valve
- Optional Air Gap Drain
- Lead-Free Standard
- US Patent Nos.: 6,443,184; 7,025,085; 7,533,699
- **Designed, Fabricated, Assembled and Tested in the USA**
- 5 Year Warranty
- Optional Mounting of Bypass on Either Side for Ease of Installation

PERFORMANCE RATING

- Maximum Working Pressure: 175 psi
- Temperature Range: 33° to 140°F, 180°F Intermittent

APPROVALS

- Approved for Horizontal Flow
- ASSE 1047 (with Meter)
- CSA B64.4
- Approved by the Foundation for Cross-Connection Control and Hydraulic Research at the University of Southern California (2-1/2" - 8" Types 1 & 2 Bypass)
- UL, ULC Classified
- FM Approved
- NSF/ANSI 372 Lead Free

STANDARD MATERIALS LIST

BODY (2-1/2"-8")	304 Stainless Steel	COVERS (10" & 12")	FDA Epoxy Coated Ductile Iron
BODY (10" & 12")	FDA Epoxy Coated Ductile Iron	CHECK VALVES	Bronze/Glass-Filled PPO/SS
COVERS (2-1/2"-6")	Glass Filled PPO/SS	SPRINGS	Stainless Steel
COVERS (8")	304 Stainless Steel	SEAT DISCS	Chloramine-Resistant Silicone

PART NUMBER MATRIX

4ALF	7 X	X	X	XX	XX
	BYPASS SUB-ASSEMBLY OPTIONS	SIZE	METER OPTION	SHUT-OFF VALVES (INLET X OUTLET)	OPTIONS
4ALF - LEAD FREE (STANDARD)	0 - TYPE 1 W/ 1/2" REDUCED PRESSURE	9 - 2-1/2"	C - CUBIC FEET/MIN	01 - LESS SHUT-OFF VALVES	D - DOMESTIC ASSEMBLY
	2 - TYPE 2 W/1/2" SINGLE CHECK	0 - 3"	E - GALLONS/MIN	03 - OS&Y FLANGE X OS&Y FLANGE	R1 - RETROFIT*
	3 - TYPE 1 W/ BYPASS ON LEFT*	A - 4"	G - LESS METER	04 - OS&Y FLANGE X MONITORED (MON.) BUTTERFLY VALVE GROOVE†	R2 - RETROFIT*
	4 - TYPE 2 W/ BYPASS ON LEFT*	C - 6"		06 - OS&Y FLANGE X POST INDICATOR FLANGE	R3 - RETROFIT*
		E - 8"		07 - OS&Y FLANGE X OS&Y GROOVE	
		G - 10"		08 - OS&Y GROOVE X OS&Y GROOVE	
		H - 12"		09 - MON. BUTTERFLY VALVE GROOVE X MON. BUTTERFLY VALVE GROOVE†	*CUSTOM LENGTH RETROFIT ORDERS MUST BE ACCOMPANIED WITH SIGNED FROM #OFBRETRO WITH EXACT LENGTH REQUIRED.
				10 - OS&Y FLANGE X POST INDICATOR GROOVE	
				13 - POST INDICATOR FLANGE X MON. BUTTERFLY VALVE GROOVE†	
				14 - POST INDICATOR FLANGE X POST INDICATOR FLANGE	
				16 - MON BUTTERFLY VALVE GROOVE X POST INDICATOR FLANGE†	
				17 - POST INDICATOR FLANGE X OS&Y GROOVE	
				18 - OS&Y GROOVE X POST INDICATOR GROOVE	
				19 - MON. BUTTERFLY VALVE GROOVE X POST INDICATOR GROOVE	
				20 - POST INDICATOR FLANGE X OS&Y FLANGE	
				21 - POST INDICATOR GROOVE X OS&Y GROOVE	
				22 - POST INDICATOR GROOVE X MON. BUTTERFLY VALVE GROOVE†	
				23 - MON. BUTTERFLY VALVE GROOVE X OS&Y FLANGE	

*Orientation of bypass looking downstream. Standard is right hand side. Left hand is on opposite side
 †Butterfly valves not available in 12" size.

RPDALF 4An SERIES

n STYLE REDUCED PRESSURE DETECTOR BACKFLOW PREVENTER ASSEMBLY



**n FLOW
TYPE 2 BYPASS**



**TYPE 2 BYPASS
VERTICAL UP FLOW**



OPTIONAL VALVE SETTER



TRIFORCE™ CHECK

The Apollo® Model RPDALF 4An Reduced Pressure Detector Assembly consists of two independently acting, TriForce™ center stem guided check valves with a differential pressure relief valve located between the check valves. The unit is designed to give maximum protection against backflow of health or non-health hazard fluids by either back-pressure or back-siphonage and at the same time detect leakage or unauthorized use of water from fire or automatic sprinkler systems. The normally vertical up/vertical down oriented body incorporates an internal swivel connection providing the ability to pivot the second check 180° to a vertical up/vertical up flow. The durable domestic stainless steel units (2-1/2" to 8") and the FDA epoxy coated ductile iron units (10" and 12") are easily maintained in the line without any special tools. The TriForce™ check valves operate with a spring assist in the flowing condition to provide low flow rates which are documented by an independent laboratory.

Available in both Type 1 and Type 2 bypass configurations. The Type 2 bypass uses the first check of the mainline assembly as the first check of the bypass. The second check of the bypass is a single check valve with a model number and serial number for test recording. This arrangement complies with the National Backflow Standards. The arrangement provides the same level of protection as the Type 1 bypass and the testing procedure is the same.

FEATURES

- Domestic Stainless Steel Body: 2-1/2"-8"
- FDA Epoxy Coated Ductile Iron Body: 10" & 12"
- Easy Maintenance: No Special Tools Required
- Drop-In Check Retainers: 2-1/2"-6"
- Bolted-In Checks: 8"-12"
- Low Pressure Loss as Documented by an Independent Approval Laboratory
- Center Stem Guided TriForce™ Check Valves
- Modular Captured Spring Relief Valve
- Optional Air Gap Drains
- Small Installation Space Required - Small Footprint
- Approved for n-Flow and Vertical Up Flow
- Chloramine-Resistant Elastomers
- **Designed, Fabricated, Assembled and Tested in the USA**
- Lead Free Standard
- Optional Valve Setters Eliminate Need for Thrust Blocks Below Grade

- US Patent Nos.: 6,443,184; 7,025,085; 7,533,699
- 5 Year Warranty
- Optional Mounting of Bypass on Either Side for Ease of Installation

PERFORMANCE RATING

- Maximum Working Pressure: 175 psi
- Temperature Range: 33° to 140°F, 180°F intermittent

APPROVALS

- CSA B64.4
- Approved by the Foundation for Cross-Connection Control and Hydraulic Research at the University of Southern California (2-1/2"-8" Type 1 Bypass)
- ASSE 1047 (with Meter)
- UL, ULC Classified
- FM Approved
- NSF/ANSI 372 Lead Free

STANDARD MATERIALS LIST

BODY (2-1/2"-8")	304 Stainless Steel	RELIEF VALVE	Bronze (LF C89836)
BODY (10 & 12")	FDA Epoxy Coated Ductile Iron	CHECK VALVES	Bronze/Glass-Filled PPO/SS
COVERS (2-1/2"-6")	Glass Filled PPO/SS	SPRINGS	Stainless Steel
COVERS (8")	304 Stainless Steel	SEAT DISCS	Chloramine-Resistant Silicone
COVERS (10" & 12")	FDA Epoxy Coated Ductile Iron		

PART NUMBER MATRIX

4ANLF	7 X	X	X	XX	X
	BYPASS SUB-ASSEMBLY OPTIONS	SIZE	METER OPTION	SHUT-OFF VALVES (INLET X OUTLET)	OPTIONS
4ANLF - LEAD FREE (STANDARD)	0 - TYPE 1 W/1/2" REDUCED PRESSURE	9 - 2-1/2"	C - CUBIC FEET/MIN	01 - LESS SHUT-OFF VALVES	D - DOMESTIC ASSEMBLY
	2 - TYPE 2 W/1/2" SINGLE CHECK	0 - 3"	E - GALLONS/MIN	03 - OS&Y FLANGE X OS&Y FLANGE	
	3 - TYPE 1 W/ BYPASS ON LEFT*	A - 4"	G - LESS METER	04 - OS&Y FLANGE X MONITORED (MON.) BUTTERFLY VALVE GROOVE†	
	4 - TYPE 2 W/ BYPASS ON LEFT*	C - 6"		06 - OS&Y FLANGE X POST INDICATOR FLANGE	
		E - 8"		07 - OS&Y FLANGE X OS&Y GROOVE	
		G - 10"		08 - OS&Y GROOVE X OS&Y GROOVE	
		H - 12"		09 - MON. BUTTERFLY VALVE GROOVE X MON. BUTTERFLY VALVE GROOVE†	
				10 - OS&Y FLANGE X POST INDICATOR GROOVE	
				13 - POST INDICATOR FLANGE X MON. BUTTERFLY VALVE GROOVE†	
				14 - POST INDICATOR FLANGE X POST INDICATOR FLANGE	
EXAMPLE: 4ANLF 70A E3 = 4" size lead free reduced pressure detector assembly with meter in GPM and OS&Y flanged inlet x OS&Y flanged outlet shut-off valves.				16 - MON BUTTERFLY VALVE GROOVE X POST INDICATOR FLANGE†	
				17 - POST INDICATOR FLANGE X OS&Y GROOVE	
				18 - OS&Y GROOVE X POST INDICATOR GROOVE	

*Orientation of bypass looking downstream. Standard is right hand side. Left hand is on opposite side
 †Butterfly valves not available in 12" size.

BACKFLOW PREVENTION

AVB1/AVB2 SERIES
ATMOSPHERIC TYPE VACUUM BREAKERS



AVB1



AVB2
SIZES 1/4", 3/8, 1/2", 3/4"
(OPTIONAL POLISHED CHROME FINISH SHOWN)

The Apollo® Series Atmospheric Type Vacuum Breakers are designed to prevent back-siphonage of polluted water into a potable water system. They should only be installed in areas where spillage of water could not cause damage and where it can be accessible for periodic maintenance. These devices are not designed for continuous pressure application (maximum 12 hours in any 24 hour period). Should be installed a minimum of 6" above all downstream piping with no downstream shutoffs.

OPERATION

During flow conditions, the flow of water lifts the float disc and seals the atmospheric vent at all rates of flow, preventing leakage. When a negative pressure is created at the supply line or when the water supply valve upstream of the device is closed, the float disc will fall, thus opening the atmospheric vent. This prevents back-siphonage and creation of vacuum at the discharge line.

FEATURES

- Corrosion Resistant
- Bronze Body (AVB1)
- Forged Body (AVB2)
- Lead Free Option (100 Series)
- Heat Resistant Silicone Seat Disc
- Rough Brass, Rough Chrome or Polished Chrome Finish
- Easy to Maintain
- Compact and Lightweight
- Durable

PERFORMANCE RATING

- Suitable for Hot or Cold Water Service: (up to 212°F at 125 psig) for up to 1" (up to 180°F at 125 psig) for 1-1/4" thru 2"

APPROVALS

- ASSE 1001
- NSF/ANSI 372 Lead Free (38LF only)

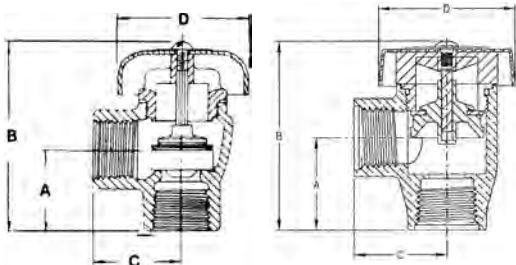

AVB1
38/38LF-10X

AVB2
38-20X

STANDARD MATERIALS LIST

VALVE BODY (AVB1)	Cast Bronze (LF C89836)
VALVE BODY (AVB2)	Forged Brass
SEAT DISC	Silicone
FLOAT & GASKET	Polypropylene
CANOPY	Powder Coated Steel
SCREW	Zinc-plated Steel

Contact local water authorities for installation/service requirements.

PART NUMBER MATRIX

38(LF) X	OX	OX
	SIZE	FINISH
1 - BRONZE	1 - 1/4"	1 - ROUGH BRASS
2 - FORGED BRASS (NOT AVAILABLE IN LF)	2 - 3/8"	3 - ROUGH CHROME (1/4" - 1" ONLY)
	3 - 1/2"	6 - POLISHED CHROME (AVB2 ONLY)
	4 - 3/4"	
	5 - 1"	
	6 - 1-1/4"	
	7 - 1-1/2"	
	8 - 2"	

DIMENSIONS

PART NO.	MODEL NO.	SIZE IN.	SIZE MM.	A (IN.)	A (MM.)	B (IN.)	B (MM.)	C (IN.)	C (MM.)	D (IN.)	D (MM.)	WT. LB.	WT. KG.
38(LF)-101	AVB114	1/4	6	29/32	23	2-3/8	60	1-1/32	26	1-13/16	46	50.96	23
38(LF)-102	AVB138	3/8	10	29/32	23	2-3/8	60	1-1/32	26	1-13/16	46	47.7	22
38-103	AVB112	1/2	15	1-3/32	28	2-1/2	65	1-3/16	30	1-3/16	30	54.7	25
38-104	AVB134	3/4	20	1-5/16	33	3-1/16	78	1-15/32	37	2-1/8	54	79.7	36
38-105	AVB11	1	25	1-3/4	45	4-1/16	103	1-7/8	48	2-7/8	73	174	79
38-106	AVB114	1-1/4	32	2	50	4-3/8	111	2	50	3-3/4	95	316	143
38-107	AVB112	1-1/2	40	2	50	4-3/8	111	2	50	3-3/4	95	289	131
38-108	AVB12	2	50	2-1/8	54	4-1/2	114	2-1/4	57	3-3/4	95	369	167

DCAP SERIES

DUAL CHECK WITH ATMOSPHERIC PORT BACKFLOW PREVENTER

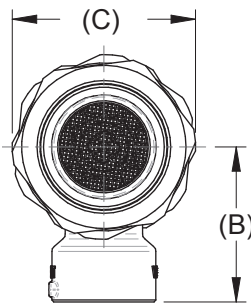
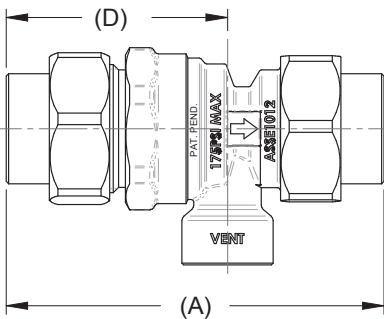

The Apollo® DCAP Series Backflow Preventer is designed to protect residential and commercial water supply lines from back-siphonage or back-pressure of non-potable (non-hazardous) substances. It has an intermediate atmospheric vent to insure protection from backflow conditions. It consists of two independently acting and spring-loaded check valves in a corrosion resistant material.

OPERATION

During normal flow operation, the vent valve is closed, and the two check valves are open allowing flow of water through the unit. Each check valve is designed to hold at least 1 psi in the direction of flow. When a back-siphonage condition occurs, both check valves close and the atmospheric vent opens to permit air to enter the intermediate zone. In the event of back-pressure and if the second check valve is prevented from closing tightly, leakage will be vented to the atmosphere through the vent port.

FEATURES

- Corrosion Resistant
- Low Head Loss
- Independently Acting Check Valves
- Ease of Repair and Installation
- Economical
- Suitable for Hot or Cold Water Service
- Durable
- Lead-Free Option
- 5 Year Warranty

PERFORMANCE RATING

- Maximum Working Pressure: 175 psig
- Inlet Temperature Range: 33° to 210°F
- Maximum backflow temperature: 250°F

APPROVALS

- ASSE 1012
- CSA B64.3
- NSF/ANSI 372 Lead Free (4ALF only)

STANDARD MATERIALS LIST

BODY	Forged Brass C87800
UNION NUT & TAILPIECES	Forged Brass C87800
SEAT DISCS	EPDM (FDA/NSF 61)
SEAT STEM & RETAINER	Forged Brass C46500
SPRINGS	Stainless Steel

DIMENSIONS

PART NUMBER	DIMENSIONS (IN.)				WT. (LB.)
	A	B	C	D	
4ALF4A33A, 4ALF4A33AC	4.1	1.6	1.9	2.4	1.31
4ALF4H33H, 4ALF4H33HC	3.9	1.6	1.9	2.3	1.24
4ALF4A44A, 4ALF4A44AC	4.3	1.6	1.9	2.5	1.32
4ALF4H44H, 4ALF4A44HC	4.4	1.6	1.9	2.6	1.29

PART NUMBER MATRIX

4A [X]	4 X	X - X	X	X
	UNION INLET CONNECTION	INLET AND OUTLET SIZE	UNION OUTLET CONNECTION	OPTION
4A - STANDARD	A - FNPT	3 - 1/2"	A - FNPT	C - CANADIAN (DISCHARGE PORT NOT THREADED)
4ALF - LEAD FREE	H - SOLDER JOINT	4 - 3/4"	B - MNPT	
			H - SOLDER JOINT	

BACKFLOW PREVENTION

DUCLF 4ALF SERIES
DUAL CHECK VALVE BACKFLOW PREVENTER



The Apollo® DUCLF-4ALF Series Dual Check Valve Backflow Preventer is designed to prevent cross-connections of non-potable water (non-hazardous) into safe drinking water systems. It is a compact and economical device that consists of two independently-acting, spring-loaded check valves in a corrosion-resistant material.

OPERATION

Each of the two spring-loaded check valves is designed to open at 1 psi differential in the direction of flow. The check valves will remain tightly closed until there is a demand for water downstream. If the downstream pressure of the device increases above the supply pressure or there is a reverse direction of flow, the check valves will close to prevent backflow. If the second check valve is prevented from closing tightly, the first check will close to provide protection from a backflow condition.

FEATURES

- Low Head Loss
- Independently-Acting Captured Spring Check Valves
- Compact and Lightweight
- Corrosion Resistant
- Replaceable Check Modules
- Industry Lay Lengths
- Available in Standard and Swivel Types
- 5 Year Warranty

PERFORMANCE RATING

- Maximum Working Pressure: 175 psi
- Operating Temperature Range: 33° to 180°F

APPROVALS

- ASSE 1024
- CSA B64.6
- NSF/ANSI 372 Lead Free (4ALF only)

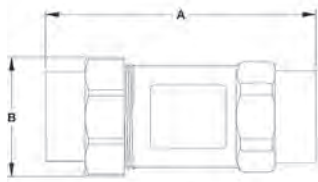

UNION X NPT

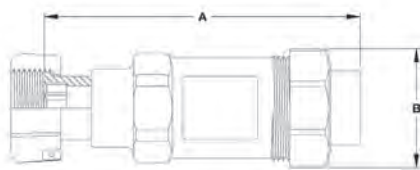

METER SWIVEL X NPT

STANDARD MATERIALS LIST

BODY	Lead Free Bronze C87800
TAILPIECE	Lead Free Brass C46500
UNION NUT	Brass C36000
CHECK MODULES	Acetal (3/4"-1")
SPRINGS	Stainless Steel
SEAT DISCS	Buna-N (3/4"-1")

Contact local water authorities for installation/service requirements.

DIMENSIONS

SIZE (IN.)	DIMENSIONS (IN.)		WT. (LB.)
	A	B	
1/2"	4.38	2.00	1.40
3/4"	4.38	2.00	1.40
3/4" Meter Swivel	4.75	2.00	1.60
1"	4.38	2.00	1.40
1" Meter Swivel	4.75	2.00	1.75

METER THREAD SIZING

5/8" METER	3/4"
3/4" METER	1"
1" METER	1-1/4"

PART NUMBER MATRIX

4ALF [X]	3 X	X X	X	X
	UNION INLET CONNECTION ^{1,2}	INLET AND OUTLET SIZE	OUTLET CONNECTION ^{1,2}	FINISH
4ALF - LEAD FREE	A - FNPT	3 - 1/2"	A - FNPT	BLANK - SATIN BRASS
	B - MNPT	4 - 3/4"	B - MNPT	
	C - FEMALE METER THREAD	5 - 1"	EXAMPLE: 4ALF 3S54A = Lead Free Dual Check with Female Swivel 1" Inlet (for 3/4" meter connection x 3/4" FNPT outlet)	
	S - FEMALE METER SWIVEL	6 - 1-1/4" (METER THREAD SIZING FOR 1" METER SWIVEL)		

¹For meter threads, order one size larger than meter size. (i.e.- 4ALF3S54A = 1" Female Meter Swivel Inlet (for connection to 3/4" meter) x 3/4" FNPT outlet

²Not all inlet and outlet combinations are available. Please contact Apollo Customer Service for availability.

DUC 4FP SERIES
DUAL CHECK VALVE BACKFLOW PREVENTER

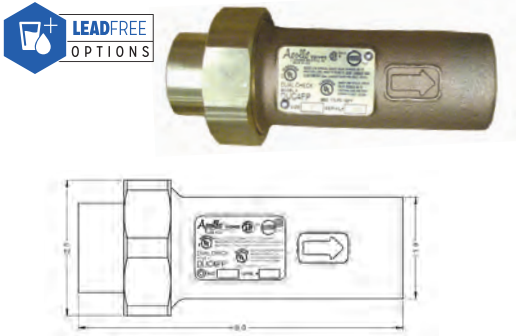

The Apollo® DUC 4FP Series Dual Check Backflow Preventer for Residential Fire Sprinkler Systems prevents backflow by either backpressure or backsiphonage from a cross-connection between potable water lines and substances that are objectionable, but not health-hazards.

FEATURES

- Low Pressure Loss
- Corrosion Resistant
- Replaceable Check Modules
- Pressure Drop at 30 gpm is Less than 6 psi
- Complies With NFPA Standard 13D
- 5 Year Warranty
- **Made in the USA**

PERFORMANCE RATING

- Maximum Operating Pressure: 175 psi
- Temperature Range: 33° to 180°F

APPROVALS

- ASSE 1024
- UL Classified
- CSA B64.6
- NSF/ANSI 372 Lead Free (4FPLF only)

STANDARD MATERIALS LIST

BODY	Bronze (C84400)	SPACER	Glass-Filled Noryl [†]
UNION NUT & TAILPIECES	Brass	O-RING	Stainless Steel
CHECK MODULES	Acetal/Nitrile/Stainless Steel		

Contact local water authorities for installation/service requirements.

EXAMPLE:
4FP3A55A = 1" Dual Check FNPT Inlet x 1" FNPT outlet

PART NUMBER MATRIX

4FP [XX]	3 X	X	X	X
	INLET CONNECTION ¹	INLET SIZE	OUTLET SIZE	OUTLET CONNECTION ¹
4FP - STANDARD	A - FNPT	5 - 1"	5 - 1"	A - FNPT
4FPLF - LEAD FREE	C - FEMALE METER THREAD	6 - 1-1/4" (METER THREAD SIZING FOR 1" METER)	6 - 1-1/4" (METER THREAD SIZING FOR 1" METER)	B - MNPT E - MALE METER THREAD

[†] Not all inlet and outlet combinations are available. Please contact Customer Service for availability.

DUC 40 SERIES
DUAL CHECK VALVE BACKFLOW PREVENTER

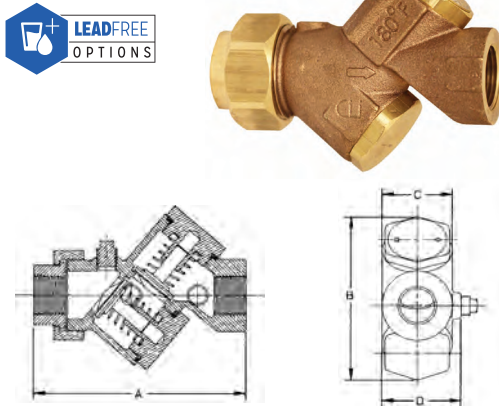

The Apollo® Series DUC 40 Dual Check Valve prevents backflow by either backpressure or back-siphonage resulting from a cross-connection between potable water lines and substances that are objectionable, but not health-hazards.

FEATURES

- In-Line Repairable
- Low Pressure Loss
- Corrosion Resistant
- Compact and Lightweight
- Independently-Acting Check Valves
- Lead-Free Option
- Available in Standard and Swivel Types
- **Made in the USA**
- 5 Year Warranty

PERFORMANCE RATING

- Maximum Operating Pressure: 175 psi
- Temperature Range: 33° to 180°F

APPROVALS

- ASSE 1024
- CSA B64.6
- NSF/ANSI 372 Lead Free (40LF only)

DIMENSIONS

PART NUMBER MODEL NUMBER	DIMENSIONS (IN.)			WT. (LB.)	WT. W/TEST COCKS & BALL VALVES
	A	B	C		
DUC4012 40-3x3-3x	4-3/8	3-1/2	3-1/2	2	4
DUC4034 40-3x4-4x	4-3/8	3-1/2	1-1/2	2	4.6
DUC401 40-3x5-5x	4-3/8	3-1/2	1-1/2	2.1	6.4

STANDARD MATERIALS LIST

BODY	Bronze (C84400 - LF C89836)
CAPS	Brass
SPRINGS	Stainless Steel
SEAT DISCS	EPDM

PART NUMBER MATRIX

40 [X]	3 X	X	X	X
	INLET CONNECTION ^{1,2}	INLET & OUTLET SIZE	OUTLET CONNECTION ^{1,2}	OPTIONS (CAN BE COMBINED)
40 - STANDARD	A - FNPT	3 - 1/2"	A - FNPT	TP - W/TEST PORTS DRILLED, TAPPED W/PLUGS
40LF - LEAD FREE	C - FEMALE METER THREAD	4 - 3/4"	C - FEMALE METER THREAD	TC - W/3 1/8"X1/4" TEST COCKS
	S - FEMALE METER SWIVEL	5 - 1"	EXAMPLE: 40 3S5 4A = 1" Dual Check Female with Meter Swivel Inlet (for connection to 3/4" meter) x 3/4"	

¹ For meter threads, order one size larger than meter size.

² Not all inlet and outlet combinations are available. Please contact Customer Service for availability.

* Standard body not drilled & tapped for test cocks.

HBV SERIES

3/4" HOSE CONNECTION VACUUM BREAKER BACKFLOW PREVENTER



3/4"
APOLLO INTERNATIONAL™
(OPTIONAL SATIN CHROME
FINISH SHOWN)

The Apollo® HBV Hose Connection Vacuum Breakers are designed to prevent cross-connection caused by back-siphonage. They consist of a single check valve with atmospheric vacuum breaker vent. They feature a break-away set-screw for tamper-proof protection. They are not suitable for continuous pressure applications.

OPERATION

At no flow situations, the check disc seats against the diaphragm with the atmospheric vent open. This prevents back-siphonage or backflow of water. At flow conditions, the spring-loaded check disc opens, thus allowing flow of water through the device and at the same time the diaphragm seals the atmospheric vent.

INSTALLATION

It should only be installed in areas where spillage of water could not cause damage. For permanent installation, screw device directly into faucet, firmly hand tighten and turn set-screw in until head breaks off.

PERFORMANCE RATING

- Maximum Working Pressure: 125 psig
- Maximum Temperature: 180° F

APPROVALS

- ASSE 1011
- CSA B64.2
- IAPMO

DIMENSIONS

PART NO.	MODEL NO.	FINISH	WT./EA
38LF-314-AS	HBVLF234	Satin Brass	.17
38LF-314-CS	HBVLC234	Satin Chrome	.17

38LF-314 shipped in 12 pcs./box

HBVB SERIES

3/4" FREEZE RESISTANT HOSE CONNECTION VACUUM BREAKER



3/4"
APOLLO INTERNATIONAL™

The Apollo® Series HBVB Freeze Resistant Hose Connection Vacuum Breaker is especially designed to prevent back-siphonage on wall and yard hydrants. It features a break-away set-screw for tamper-proof protection and automatic drain for protection against freezing conditions when hose is removed. It is not suitable for continuous pressure applications.

OPERATION

The principle of operation is similar to the HCVB Series except it has an automatic draining feature. When the hose is removed, the internal mechanism opens to drain water from the unit and the hose bibb to help prevent water from freezing inside the unit.

INSTALLATION

It should only be installed in areas where spillage of water could not cause damage. For permanent installation, screw device directly into faucet, firmly hand tighten and turn set-screw in until head breaks off.

PERFORMANCE RATING

- Maximum Working Pressure: 125 psig
- Maximum Temperature: 180° F

APPROVALS

- ASSE 1011

DIMENSIONS

PART NO.	MODEL NO.	FINISH	WT./EA
38LF-414-AS	HBVBLF2	Satin Brass	.37

HBDUC SERIES

3/4" HOSE CONNECTION/LAB FAUCET DUAL CHECK BACKFLOW PREVENTER



38-304-02
SIZE 3/4"

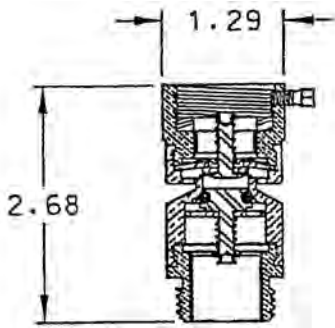

The Apollo® Series HBDUC is designed to provide an in-line testable hose connection that will prevent backflow due to back-siphonage or low head back-pressure. Each device consists of two independent checks, forced loaded in the closed position with an atmospheric vent between the checks. The device is threaded for hose connection at both the inlet and outlet with a break-away set screw on the inlet for tamper proof installations. These devices are not suitable for continuous pressure applications.

OPERATION

During initial pressurization, the inlet check shuttles forward to close the atmospheric vent. As flow is established, both the inlet and outlet check open to allow flow through the device. If a backflow condition is present, then both checks will close and the atmospheric vent opens to introduce air and break the siphon.

FEATURES

- Corrosion Resistant Body and Checks
- Low Head Loss
- Easy to Install With Break-Away Set Screw
- Protects Against Back Siphonage and Low Head Back Pressure

STANDARD MATERIALS LIST

BODY	Brass
SEATS	EPDM
CHECK COMPONENTS	Stainless Steel
CHECK GUIDE	Acetal

Contact local water authorities for installation/service requirements.

DIMENSIONS

PART NO.	MODEL NO.	WT./EA
38-304-02	HBDUC34	.46
38LF-304-02	HBDUCLF34	.46

LFDUC SERIES

LAB FAUCET DUAL CHECK BACKFLOW PREVENTER

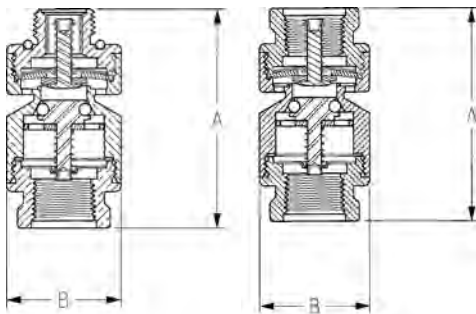

The Apollo® Series LFDUC is designed to provide protection against back-siphonage wherever a hose is connected to a faucet. The device consists of two independently acting checks with an intermediate relief port or vent. It is suitable for supply pressure up to 150 psig and a temperature range of 33°F-212°F. Not suitable for constant pressure conditions.

OPERATION

During normal flow conditions, the two checks are held off their seats, supplying water downstream. The vent is held shut by supply pressure acting on the diaphragm. If the supply pressure should fall below atmospheric, the second check will close due to internal spring pressure and the vent will open to introduce air into the supply line and break the siphon. Note: This device should only be installed where spillage of water could not cause water damage.

FEATURES

- Corrosion Resistant
- Suitable for Hot or Cold Water Service up to 212° F and 125 psi
- Lead Free Option
- Polished
- Easy to Maintain
- Compact and Lightweight

APPROVALS

- ASSE 1035
- NSF/ANSI 372 Lead Free

DIMENSIONS

PART NO.	MODEL NO.	INLET	OUTLET	A (IN.)	B (IN.)	WT./EA
38-502-01	LFDUCMF38	3/8" MNPSM*	3/8" FNPT	2.33	1.24	.50
38-502-02	LFDUCFF38	3/8" FNPT	3/8" FNPT	2.34	1.24	.50
38-502-03	LFDUCFM38	3/8" FNPT	3/8" MNPSM	2.33	1.24	.50
38-502-CP2**	LFDUCFF14	1/4" FNPT	1/4" FNPT	2.34	1.24	.50
38-502-CP3**	LFDUCFF38	3/8" FNPT	3/8" FNPT	2.34	1.24	.50

*American National Standard straight pipe thread for free-fitting mechanical joints (male)
**-CP2 and -CP3 are non-approved devices with a rough brass finish for continuous pressure applications

FPV SERIES
FREEZE PROTECTION VALVE

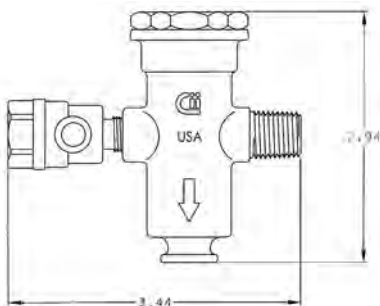
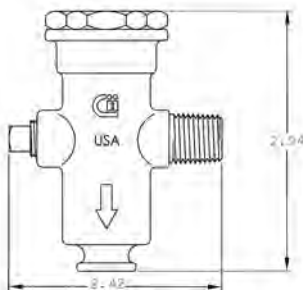

The Apollo® Series FPV Freeze Protection Valve protects backflow preventers from freezing when installed in accordance with manufacturer's instructions. All internal parts of the Freeze Protection Valve are replaceable.

OPERATION

During flow conditions, the Freeze Protection Valve shall be drip-tight during above-freezing normal operating conditions. The Freeze Protection Valve shall be suitable for normal operating pressures of 20 to 175 psig.

FEATURES

- Installs Easily on All Backflow Preventers
- Ease of Repair with Available Repair Kit
- Corrosion Resistant
- 1/4" Male Pipe Thread Inlet Port
- Available With 1/8" M x 1/4" F Testcock
- Discharge Port Accommodates 5/8" I.D. Hose
- Lead-Free Option
- Mechanical Operating Principle
- Compact Design
- IAPMO listed
- US Patent #6,374,849
- 5 Year Warranty

PERFORMANCE RATING

- Nominal Start to Open Temperature of 35°F
- Maximum Operating Pressure: 175 psig
- Maximum Temperature of 180°F

APPROVALS

- NSF/ANSI 372 Lead Free (40LF only)

STANDARD MATERIALS LIST

BODY	Bronze (C84400/LF C89836)
CAP	Brass
SPRING GUIDE	Brass
SPRING	Stainless Steel
CAP O-RING	Buna-N
GUIDE O-RING	Buna-N
THERMAL ELEMENT	Copper/Stainless Steel/EPDM

Contact local water authorities for installation/service requirements.

WEIGHTS

MODEL NO.	NET WEIGHT (LB.)
40-000-FPV1	.70
40-000-FPV2	.77

MODEL NUMBERS

MODEL NO.
40-000-FPV1
40-000-FPV2 - w/test cock
40LF-000-FPV1
40LF-000-FPV2F - w/SAE testcock

PART NUMBER MATRIX

40 [X]	000	FPV X
		OPTIONS
40	- STANDARD	1 - W/1/8" NPT PLUG
40LF	- LEAD FREE	2 - W/1/8" MALE X 1/4" FEMALE TEST COCK
		2F - SAE TEST COCK
		R - REPAIR KIT* FOR FPV1 AND FPV2

* Repair kit includes: Thermal element, spring, spring guide, two o-rings (all internal parts)

CBBP SERIES

CARBONATED BEVERAGE BACKFLOW PREVENTER

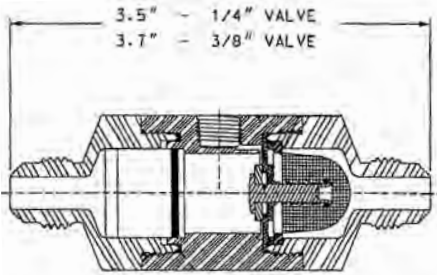

The Apollo® CBBP Series Carbonated Beverage Backflow Preventer (CBBP) is designed to prevent the contamination of the potable water supply due to backflow when installed on water distribution lines serving beverage dispensing equipment. The device consists of two independently acting check valves biased to a normally closed position. A normally open atmospheric port is located between the check valves. During backflow conditions, the port vents gases and/or liquids. Additionally, the CBBP is equipped with a 100 mesh integral strainer screen at the inlet. All wetted areas of the device are non-toxic, corrosion resistant, and approved for use with potable water. The CBBP is suitable for supply pressures to 150 psig and water temperatures from 33° to 130° F.

OPERATION

Under static (non-flowing) conditions, the check valves remain in the closed position. When a valve is opened downstream (i.e. a beverage is delivered from the beverage dispensing unit), the check valves open and permit the flow of water. Under backflow conditions, the diaphragm seat on the first check lifts and permits flow through the atmospheric port located between the two check valves. The strainer insures debris does not enter the backflow preventer.

FEATURES

- Compact Design
- Lowest Head Loss
- Atmospheric Vent Provides Indication of Problems
- Integral Strainer for Equipment Protection
- Lead Free
- 5 Year Warranty
- Available in SAE & NPT Connections
- Repairable Check Assemblies
- Non-Metallic Body for Corrosion Resistance

APPROVALS

- CSA
- NSF/ANSI 61 Water Quality
- ASSE 1022
- IAPMO® Listed

STANDARD MATERIALS LIST

END CAP	Acetal
STRAINER	PVC/Stainless Steel
O-RING	Nitrile
UPSTREAM CHECK	Nitrile/Stainless Steel/Acetal
DOWNSTREAM CHECK	EPDM/Stainless
VALVE BODY	Acetal

Contact local water authorities for installation/service requirements.

PART NUMBER MATRIX

4C10 X	X
SIZE	INLET AND OUTLET CONNECTION
1 - 1/4"	01 - FLARE
2 - 3/8"	02 - MNPT (3/8" ONLY)

DIMENSIONS

SIZE	CONNECTION SIZING		WT./EA
1/4"	7/16"-20 UNF	SAE Flare	.19
3/8"	5/8"-18 UNF	SAE Flare	.19
3/8"	3/8" NPT	Male NPT	.19

BACKFLOW PREVENTION

**4A, 4AN AND RPS 40 SERIES
AIR GAP DRAIN**



For installation with all 4A, 4AN and RPS 40 Series Reduced Pressure Principle backflow preventers.

The Apollo® Air Gap Drain (AGD) is designed to funnel minor relief valve discharges, due to line pressure fluctuations and /or minor check valve fouling, into the drainage system. Drain piping is easily attached to the drain's threaded bottom.

Note: The AGD is designed to collect expected minor discharges due to fouled checks or pressure fluctuations but not the full discharge capacity of the relief valve.

AGD4A6 (2-1/2" - 6")

RP SIZE	AIR GAP PART NUMBER	DIMENSIONS (IN.)				OUTLET CONNECTION (FNPT)	WT. (LB.)
		A	B	C	D		
RP4A							
2-1/2"	AGD4A6	11.28	-	2.63	3.13	2"	0.7
3"	AGD4A6	11.28	-	2.63	3.13	2"	0.7
4"	AGD4A6	12.02	-	2.63	3.13	2"	0.7
6"	AGD4A6	13.32	-	2.63	3.13	2"	0.7
RP4AN							
2-1/2"	AGD4A6	-	10.87	2.63	3.13	2"	0.7
3"	AGD4A6	-	10.87	2.63	3.13	2"	0.7
4"	AGD4A6	-	10.51	2.63	3.13	2"	0.7
6"	AGD4A6	-	11.76	2.63	3.13	2"	0.7

AGD4A8 (8")

RP STYLE	AIR GAP PART NUMBER	DIMENSIONS (IN.)		OUTLET PIPE SIZE	OUTLET CONNECTION (FNPT)	WT. (LB.)
		A	B			
RP4A	AGD4A8	21.3	9.1	3"	2-1/2"	1.5
RP4AN	AGD4A8	19.8	9.1	3"	2-1/2"	1.5

AGD4A12 (10" & 12")

RP STYLE	AIR GAP PART NUMBER	DIMENSIONS (IN.)		OUTLET PIPE SIZE	OUTLET CONNECTION (FNPT)	WT. (LB.)
		A	B			
RP4A	AGD4A12	26.3	7.7	4"	3"	5
RP4AN	AGD4A12	23.4	7.7	4"	3"	5

BACKFLOW PREVENTION

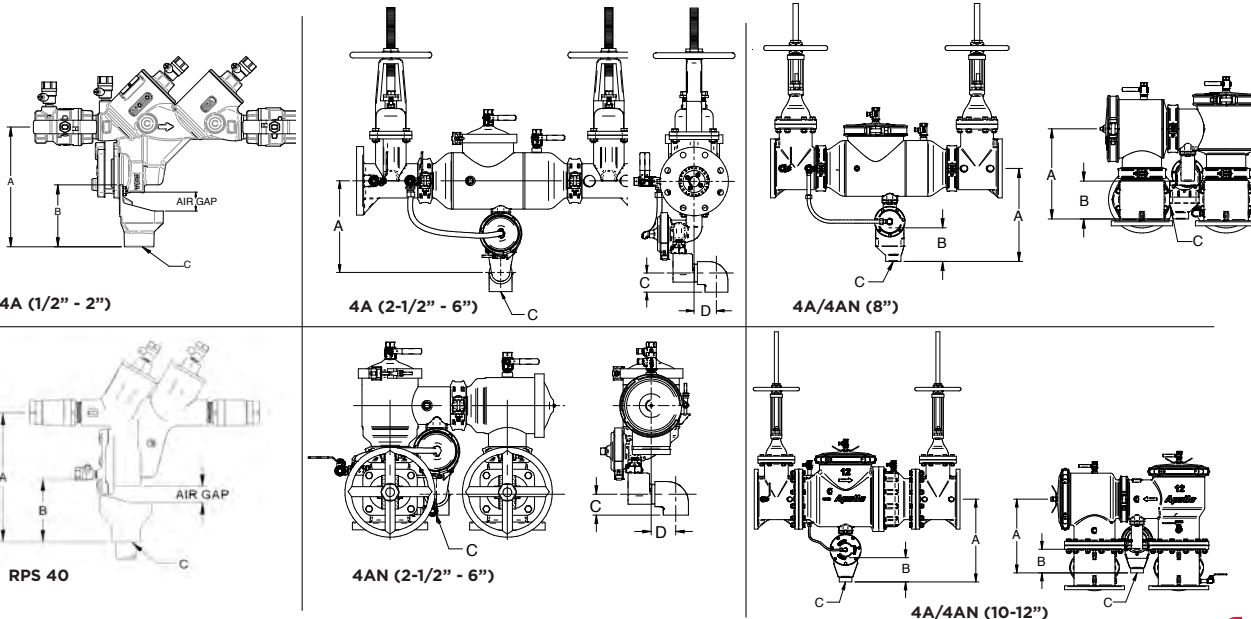

"Apollo"®

BRONZE GATE VALVES

101S, 101S-LF	J2
101T, 101T-LF	J2
102S, 102S-LF	J2
102T, 102T-LF	J3
102T-K	J3
103T	J3
106T	J4
107T	J4
111T	J4
116T	J4

CAST IRON GATE VALVES

610F	J-5
620F	J-5
611F	J-6
621F	J-6

BRONZE GLOBE VALVES

120S, 120S-LF	J-7
120T, 120T-LF	J-7
121T, 121T-LF	J-7
122T	J-8
127T	J-8
128T	J-8

CAST IRON GLOBE VALVES

711F	J-9
721F	J-9

BRONZE SWING CHECKS

161S, 161S-LF	J-10
161T, 161T-LF	J-10
162T	J-10
163S, 163S-LF	J-10
163T, 163T-LF	J-11
164T	J-11
168T	J-11
169T	J-11

CAST IRON SWING CHECKS

910F	J-12
910FLW	J-12
920F	J-13

CAST IRON WAFER CHECKS

910WB	J-14
910WE	J-14

BRONZE IN-LINE CHECKS

61-100/200	J-22
61LF-100	J-22
61-500/600	J-24
61LF-500/600	J-24
70-100-BC	J-27

STAINLESS STEEL IN-LINE CHECKS

61-100/200	J-23
62-500	J-25

BRASS IN-LINE CHECKS

61-700	J-26
--------	------

IN-LINE CHECK REPAIR KITS	J-28
---------------------------	------

GATE, GLOBE, & CHECK VALVES

MODEL 101S/101S-LF
SOLDER END RISING STEM GATE VALVE



FEATURES

- Threaded Bonnet
- Solid Bronze Disc
- 200 CWP
- Max. Temp: 406°F
- Lead Free Option (NSF 61/NSF 372)

STANDARDS

- MSS SP-80 Standard
- MSS SP-139 Lead Free Option (CWP only)
- ASTM B62 Bronze (ASTM B584-C89836 Lead Free)



PART NUMBER	LF PART NUMBER	NPS	LENGTH (IN.)	HEIGHT (IN.)	WEIGHT (LB.)
30-083-01	30LF-083-01	1/2	1.88	4.85	1.00
30-084-01	30LF-084-01	3/4	2.43	5.71	1.30
30-085-01	30LF-085-01	1	2.96	6.71	2.20
30-086-01	30LF-086-01	1-1/4	3.14	8.10	3.20
30-087-01	30LF-087-01	1-1/2	3.44	9.08	4.40
30-088-01	30LF-088-01	2	4.11	11.28	7.00
30-089-01	30LF-089-01	2-1/2	4.79	14.58	13.80
30-080-01	30LF-080-01	3	5.43	19.07	17.70

Length is measured from end-to-end.
Height is measured from centerline to top of wheel in full open position.

MODEL 101T/101T-LF
NPT END RISING STEM GATE VALVE



FEATURES

- Threaded Bonnet
- Solid Bronze Disc
- 200 CWP
- 125 SWP
- Max. Temp: 406°F
- Lead Free Option (NSF 61/NSF 372)

STANDARDS

- MSS SP-80 Standard
- MSS SP-139 Lead Free Option (CWP only)
- ASTM B62 Bronze (ASTM B584-C89836 Lead Free)



PART NUMBER	LF PART NUMBER	NPS	LENGTH (IN.)	HEIGHT (IN.)	WEIGHT (LB.)
30-001-01	30LF-001-01	1/4	1.76	4.57	0.80
30-002-01	30LF-002-01	3/8	1.76	4.51	0.77
30-003-01	30LF-003-01	1/2	2.03	4.85	1.00
30-004-01	30LF-004-01	3/4	2.07	5.71	1.30
30-005-01	30LF-005-01	1	2.45	6.71	2.16
30-006-01	30LF-006-01	1 1/4	2.63	8.10	3.20
30-007-01	30LF-007-01	1 1/2	2.88	9.08	4.36
30-008-01	30LF-008-01	2	3.06	11.28	7.01
30-009-01	30LF-009-01	2 1/2	4.13	14.58	13.79
30-000-01	30LF-000-01	3	4.48	19.07	17.70

Length is measured from end-to-end.
Height is measured from centerline to top of wheel in full open position.

MODEL 102S/102S-LF
SOLDER END-NON RISING STEM GATE VALVE



FEATURES

- Threaded Bonnet
- Solid Bronze Disc
- 200 CWP
- Max. Temp: 406°F
- Lead Free Option (NSF 61/NSF 372)

STANDARDS

- MSS SP-80 Standard
- MSS SP-139 Lead Free Option (CWP only)
- ASTM B62 Bronze (ASTM B584-C89836 Lead Free)



PART NUMBER	LF PART NUMBER	NPS	LENGTH (IN.)	HEIGHT (IN.)	WEIGHT (LB.)
30-043-01	30LF-043-01	1/2	1.88	3.56	0.85
30-044-01	30LF-044-01	3/4	2.43	4.05	1.19
30-045-01	30LF-045-01	1	2.96	4.55	1.98
30-046-01	30LF-046-01	1 1/4	3.14	5.14	2.80
30-047-01	30LF-047-01	1 1/2	3.44	6.02	3.95
30-048-01	30LF-048-01	2	4.11	7.09	5.88
30-049-01	30LF-049-01	2 1/2	4.79	9.11	12.19
30-040-01	30LF-040-01	3	5.43	12.61	16.84

Length is measured from end-to-end. Height is measured from centerline to top of wheel in full open position.



MODEL 102T/102T-LF
NPT END NON-RISING STEM GATE VALVE



FEATURES

- Threaded Bonnet
- Solid Bronze Disc
- 200 CWP
- 125 SWP
- Max Temp: 406°F
- Lead Free Option (NSF 61/NSF 372)

STANDARDS

- MSS SP-80 Standard
- MSS SP-139 Lead Free Option (CWP only)
- ASTM B62 Bronze (ASTM B584-C89836 Lead Free)



PART NUMBER	LF PART NUMBER	NPS	LENGTH (IN.)	HEIGHT (IN.)	WEIGHT (LB.)
30-031-01	30LF-031-01	1/4	1.76	3.29	0.74
30-032-01	30LF-032-01	3/8	1.76	3.29	0.71
30-033-01	30LF-033-01	1/2	2.03	3.56	0.85
30-034-01	30LF-034-01	3/4	2.07	4.05	1.19
30-035-01	30LF-035-01	1	2.45	4.55	1.98
30-036-01	30LF-036-01	1-1/4	2.63	5.14	2.80
30-037-01	30LF-037-01	1-1/2	2.88	6.02	3.95
30-038-01	30LF-038-01	2	3.06	7.09	5.88
30-039-01	30LF-039-01	2-1/2	4.13	9.11	12.19
30-030-01	30LF-030-01	3	4.48	12.61	16.84

*Length is measured from end-to-end.
Height is measured from centerline to top of wheel in full open position.*

MODEL 102T-K
NPT END NON-RISING STEM IRRIGATION GATE VALVE

FEATURES

- Threaded Bonnet
- Solid Bronze Disc
- Bronze Cross-Handle (Irrigation)
- 200 CWP
- 125 SWP
- Max Temp: 406°F
- SS Stem Nut

STANDARDS

- MSS SP-80 Standard
- ASTM B62 Bronze



PART NUMBER	NPS	LENGTH (IN.)	HEIGHT (IN.)	WEIGHT (LB.)
30-033-01K	1/2	2.03	3.56	0.85
30-034-01K	3/4	2.07	4.05	1.19
30-035-01K	1	2.45	4.55	1.98
30-036-01K	1 1/4	2.63	5.14	2.80
30-037-01K	1 1/2	2.88	6.02	3.95
30-038-01K	2	3.06	7.09	5.88
30-039-01K	2 1/2	4.13	9.11	12.19
30-030-01K	3	4.48	12.61	16.84

*Length is measured from end-to-end.
Height is measured from centerline to top of wheel in full open position.
30LF-03X-01K available upon request.*

MODEL 103T
NPT END RISING STEM GATE VALVE

FEATURES

- Threaded Bonnet
- Solid Bronze Disc
- 200 CWP
- 125 SWP
- Max. Temp: 406°F
- Lead Free Option (NSF 61/NSF 372)

STANDARDS

- MSS SP-80 Standard
- ASTM B62 Bronze



PART NUMBER	NPS	LENGTH (IN.)	HEIGHT (IN.)	WEIGHT (LB.)
30-051-01	1/4	1.76	4.57	0.90
30-052-01	3/8	1.76	4.51	0.86
30-053-01	1/2	2.03	4.85	1.07
30-054-01	3/4	2.07	5.71	1.43
30-055-01	1	2.45	6.71	2.44
30-056-01	1 1/4	2.63	8.10	3.71
30-057-01	1 1/2	2.88	9.08	4.89
30-058-01	2	3.06	11.28	7.53
30-059-01	2 1/2	4.96	14.58	15.33
30-050-01	3	4.48	19.07	19.56

*Length is measured from end-to-end.
Height is measured from centerline to top of wheel in full open position.*



MODEL 106T
CLASS 150 NPT NON-RISING STEM GATE VALVE

FEATURES

- Threaded Bonnet
- Solid Bronze Disc
- 300 CWP
- 150 SWP
- Max. Temp: 406°F

STANDARDS

- Meets MSS SP-80 Standard
- ASTM B62 Bronze Materials



PART NUMBER	NPS	LENGTH (IN.)	HEIGHT (IN.)	WEIGHT (LB.)
30-281-01	1/4	1.76	3.29	0.74
30-282-01	3/8	1.76	3.29	0.71
30-283-01	1/2	2.03	3.56	0.98
30-284-01	3/4	2.07	4.05	1.21
30-285-01	1	2.45	4.55	1.98
30-286-01	1 1/4	2.63	5.14	2.80
30-287-01	1 1/2	2.88	6.02	4.06
30-288-01	2	3.06	7.09	5.88
30-289-01	2 1/2	4.13	9.11	12.19
30-280-01	3	4.48	12.61	16.90

*Length is measured from end-to-end.
Height is measured from centerline to top of wheel in full open position.*

MODEL 107T
CLASS 150 NPT RISING STEM GATE VALVE

FEATURES

- Union Bonnet
- Solid Bronze Disc
- 300 CWP
- 150 SWP
- Max. Temp: 406°F

STANDARDS

- Meets MSS SP-80 Standard
- ASTM B62 Bronze Materials



PART NUMBER	NPS	LENGTH (IN.)	HEIGHT (IN.)	WEIGHT (LB.)
30-201-01	1/4	1.76	4.57	0.90
30-202-01	3/8	1.76	4.51	0.86
30-203-01	1/2	2.03	4.85	1.07
30-204-01	3/4	2.07	5.71	1.43
30-205-01	1	2.45	6.71	2.50
30-206-01	1 1/4	2.63	8.10	3.69
30-207-01	1 1/2	2.88	9.13	5.01
30-208-01	2	3.06	11.28	7.53
30-209-01	2 1/2	4.13	14.58	15.33
30-200-01	3	4.48	16.90	19.56

*Length is measured from end-to-end.
Height is measured from centerline to top of wheel in full open position.*

MODEL 111T/116T
CLASS 300 NPT RISING STEM GATE VALVE

FEATURES

- Union Bonnet
- Solid Bronze Disc
- Model 116T has Type 316 SS Seats
- 1000 CWP
- 300 SWP
- Max. Temp: 406°F

STANDARDS

- Meets MSS SP-80 Standard
- ASTM B61 Bronze Materials



PART NUMBER	SS SEAT PART NUMBER	NPS	LENGTH (IN.)	HEIGHT (IN.)	WEIGHT (LB.)
30-443-01	30-453-01	1/2	2.31	4.97	1.40
30-444-01	30-454-01	3/4	2.56	6.22	2.30
30-445-01	30-455-01	1	2.89	6.94	3.50
30-446-01	30-456-01	1 1/4	3.01	8.29	5.10
30-447-01	30-457-01	1 1/2	3.05	9.28	6.80
30-448-01	30-458-01	2	3.08	11.37	9.60

*Length is measured from end-to-end.
Height is measured from centerline to top of wheel in full open position.*



MODEL 610F
CLASS 125 FLANGED GATE VALVE



PERFORMANCE RATING STANDARD

- Saturated Steam:
 - 125 psi (8.6 Bar) at 353° F (2"-12")
 - 100 psi (6.9 Bar) at 338° F (14"-24")
- Cold Working Pressure:
 - 200 psi (13.8 Bar) at 100° F (2"-12")
 - 150 psi (10.3 Bar) at 100° F (14"-24")
- Temperature Range: -20° to 406° F max

LEAD FREE (-LF)

- Cold Working Pressure:
 - 200 psi (13.8 Bar) at 100° F (2"-12")
 - 150 psi (10.3 Bar) at 100° F (14"-24")
- Temperature Range: -20° to 180° F max

FEATURES

- Compatible with ANSI 125# & 150# Flanges
- Full Port
- Bronze Mounted Seat Rings/Trim
- Solid Wedge
- Adjustable Graphite Stem Packing
- Non-Rising Stem
- Flanged Connection
- Bolted Bonnet
- Rugged Iron Hand Wheel
- Back Seat Protection

STANDARDS

- MSS SP-70 - Gray Iron Gate Valves Flanged and Threaded - Type 1
- ASME B16.10 - Face-to-Face and End-to-End Dimensions of Valves

APPROVALS (LEAD FREE ONLY)

- NSF/ANSI 372 Lead Free
- NSF/AND 61 Water Quality

STANDARD PART # (STEAM RATED)	-LF PART # (NOT FOR STEAM)	-LFA PART # (STEAM RATED)	NPS	LENGTH (IN.)	HEIGHT (IN.)	WEIGHT (LB.)
6GA-108-B1	-	6GA-108-B1-LFA	2	7.00	14.57	36.0
6GA-109-B1	6GA-109-B1-LF	6GA-109-B1-LFA	2 1/2	7.50	16.34	48.0
6GA-100-B1	6GA-100-B1-LF	6GA-100-B1-LFA	3	8.00	18.90	59.0
6GA-10A-B1	-	6GA-10A-B1-LFA	4	9.00	20.67	104
6GA-10B-B1	-	6GA-10B-B1-LFA	5	10.00	24.61	150
6GA-10C-B1	-	6GA-10C-B1-LFA	6	10.50	28.74	192
6GA-10E-B1	-	6GA-10E-B1-LFA	8	11.50	32.48	260
6GA-10G-B1	-	6GA-10G-B1-LFA	10	13.00	37.40	434
6GA-10H-B1	-	6GA-10H-B1-LFA	12	14.00	43.31	606
-	-	6GA-10J-B1-LFA	14	15.00	37.01	926
-	-	6GA-10K-B1-LFA	16	16.00	42.52	1098
-	-	6GA-10M-B1-LFA	18	17.00	46.46	1543
-	-	6GA-10N-B1-LFA	20	18.00	54.33	1638
-	-	6GA-10P-B1-LFA	24	20.00	57.48	2756

Length is measured from end-to-end. Height is measured from centerline to top of wheel in full open position. NOTE: Flat face mating flanges and full face gaskets must be installed to avoid damage to the cast iron body.

MODEL 620F
CLASS 250 FLANGED GATE VALVE



PERFORMANCE RATING STANDARD

- Saturated Steam:
 - 125 psi (8.6 Bar) at 353° F (2"-12")
- Cold Working Pressure:
 - 500 psi (34.4 Bar) at 100° F (2"-12")
- Temperature Range: -20° to 406° F max

LEAD FREE (-LF)

- Cold Working Pressure:
 - 500 psi (34.4 Bar) at 100° F (2"-12")
- Temperature Range: -20° to 180° F max

FEATURES

- Compatible with ANSI 250# & 300# Flanges
- Full Port
- Bronze Mounted Seat Rings/Trim
- Solid Wedge
- Adjustable Graphite Stem Packing
- Non-Rising Stem
- Flanged Connection
- Bolted Bonnet
- Rugged Iron Hand Wheel
- Back Seat Protection

STANDARDS

- MSS SP-70 - Gray Iron Gate Valves Flanged and Threaded - Type 1
- ASME B16.10 - Face-to-Face and End-to-End Dimensions of Valves

APPROVALS (LEAD FREE ONLY)

- NSF/ANSI 372 Lead Free
- NSF/AND 61 Water Quality

STANDARD PART # (STEAM RATED)	-LF PART # (NOT FOR STEAM)	-LFA PART # (STEAM RATED)	*NPS	LENGTH (IN.)	HEIGHT (IN.)	WEIGHT (LB.)
6GA-208-B1	-	6GA-208-B1-LFA	2	8.50	11.28	42.0
6GA-209-B1	6GA-209-B1-LF	6GA-209-B1-LFA	2 1/2	9.50	12.72	55.0
-	6GA-200-B1-LF	6GA-200-B1-LFA	3	11.00	13.31	66.0
6GA-20A-B1	6GA-20A-B1-LF	6GA-20A-B1-LFA	4	12.00	16.18	115
-	-	6GA-20C-B1-LFA	6	16.00	22.00	205
6GA-20E-B1	-	6GA-20E-B1-LFA	8	16.50	25.59	278
6GA-20G-B1	6GA-20G-B1-LF	6GA-20G-B1-LFA	10	18.00	30.31	456
-	-	6GA-20H-B1-LFA	12	19.75	33.90	633

Length is measured from end-to-end. Height is measured from centerline to top of wheel in full open position. NOTE: Class 250 flanges and flanged fittings have a 0.06 inch raised face in accordance with MSS SP-6.

MODEL 611F
CLASS 125 FLANGED OS&Y GATE VALVE



PERFORMANCE RATING STANDARD

- Saturated Steam:
 - 125 psi (8.6 Bar) at 353° F (2"-12")
 - 100 psi (6.9 Bar) at 338° F (14"-24")
- Cold Working Pressure:
 - 200 psi (13.8 Bar) at 100° F (2"-12")
 - 150 psi (10.3 Bar) at 100° F (14"-24")
- Temperature Range: -20° to 406° F max

LEAD FREE (-LF)

- Cold Working Pressure:
 - 200 psi (13.8 Bar) at 100° F (2"-12")
 - 150 psi (10.3 Bar) at 100° F (14"-24")
- Temperature Range: -20° to 180° F max

FEATURES

- Compatible with ANSI 125# & 150# Flanges
- Full Port
- Bronze Mounted Seat Rings/Trim
- Solid Wedge
- Adjustable Graphite Stem Packing
- Outside Screw & Yoke
- Flanged Connection
- Bolted Bonnet
- Rugged Iron Hand Wheel
- Back Seat Protection

STANDARDS

- MSS SP-70 - Gray Iron Gate Valves Flanged and Threaded - Type 1
- ASME B16.10 - Face-to-Face and End-to-End Dimensions of Valves

APPROVALS (LEAD FREE ONLY)

- NSF/ANSI 372 Lead Free
- NSF/AND 61 Water Quality

STANDARD PART # (STEAM RATED)	-LF PART # (NOT FOR STEAM)	-LFA PART # (STEAM RATED)	NPS	LENGTH (IN.)	HEIGHT (IN.)	WEIGHT (LB.)
6GA-118-B1	6GA-118-B1-LF	6GA-118-B1-LFA	2	7.00	14.96	38.0
-	6GA-119-B1-LF	6GA-119-B1-LFA	2 1/2	7.50	16.93	51.0
-	6GA-110-B1-LF	6GA-110-B1-LFA	3	8.00	19.09	62.0
-	-	6GA-11A-B1-LFA	4	9.00	24.21	110
6GA-11B-B1	6GA-11B-B1-LF	6GA-11B-B1-LFA	5	10.00	27.56	154
-	-	6GA-11C-B1-LFA	6	10.50	32.87	203
-	-	6GA-11E-B1-LFA	8	11.50	37.76	284
6GA-11G-B1	-	6GA-11G-B1-LFA	10	13.00	48.03	459
6GA-11H-B1	6GA-11H-B1-LF	6GA-11H-B1-LFA	12	14.00	56.50	637
-	-	6GA-11J-B1-LFA	14	15.00	65.16	966
-	-	6GA-11K-B1-LFA	16	16.00	71.85	1135
-	-	6GA-11M-B1-LFA	18	17.00	79.53	1753
-	-	6GA-11N-B1-LFA	20	18.00	90.16	2238
-	-	6GA-11P-B1-LFA	24	20.00	132.28	3197

Length is measured from end-to-end. Height is measured from centerline to top of wheel in full open position. NOTE: Flat face mating flanges and full face gaskets must be installed to avoid damage to the cast iron body.

MODEL 621F
CLASS 250 FLANGED OS&Y GATE VALVE



PERFORMANCE RATING STANDARD

- Saturated Steam:
 - 125 psi (8.6 Bar) at 353° F (2"-12")
- Cold Working Pressure:
 - 500 psi (34.4 Bar) at 100° F (2"-12")
- Temperature Range: -20° to 406° F max

LEAD FREE (-LF)

- Cold Working Pressure:
 - 500 psi (34.4 Bar) at 100° F (2"-12")
- Temperature Range: -20° to 180° F max

FEATURES

- Compatible with ANSI 250# & 300# Flanges
- Full Port
- Bronze Mounted Seat Rings/Trim
- Solid Wedge
- Adjustable Graphite Stem Packing
- Outside Screw & Yoke
- Flanged Connection
- Bolted Bonnet
- Rugged Iron Hand Wheel
- Back Seat Protection

STANDARDS

- MSS SP-70 - Gray Iron Gate Valves Flanged and Threaded - Type 1
- ASME B16.10 - Face-to-Face and End-to-End Dimensions of Valves

APPROVALS (LEAD FREE ONLY)

- NSF/ANSI 372 Lead Free
- NSF/AND 61 Water Quality

STANDARD PART # (STEAM RATED)	-LF PART # (NOT FOR STEAM)	-LFA PART # (STEAM RATED)	NPS	LENGTH (IN.)	HEIGHT (IN.)	WEIGHT (LB.)
-	6GA-218-B1-LF	6GA-218-B1-LFA	2	8.50	14.96	44.0
6GA-219-B1	6GA-219-B1-LF	6GA-219-B1-LFA	2 1/2	9.50	16.93	57.0
-	6GA-210-B1-LF	6GA-210-B1-LFA	3	11.12	19.09	71.0
6GA-21A-B1	6GA-21A-B1-LF	6GA-21A-B1-LFA	4	12.00	24.21	121
6GA-21B-B1	-	6GA-21B-B1-LFA	5	15.00	27.56	165
6GA-21C-B1	-	6GA-21C-B1-LFA	6	15.88	32.87	216
6GA-21E-B1	6GA-21E-B1-LF	6GA-21E-B1-LFA	8	16.50	39.76	302
6GA-21G-B1	6GA-21G-B1-LF	6GA-21G-B1-LFA	10	18.00	48.03	481
-	-	6GA-21H-B1-LFA	12	19.75	56.50	642

Length is measured from end-to-end. Height is measured from centerline to top of wheel in full open position. NOTE: Class 250 flanges and flanged fittings have a 0.06 inch raised face in accordance with MSS SP-6.



MODEL 120S/120S-LF
SOLDER END GLOBE VALVE



FEATURES

- Threaded Bonnet
- PTFE Disc
- 200 CWP
- Max. Temp: 406°F
- Lead Free Option (NSF 61/NSF 372)



MODEL NUMBER	LF PART NUMBER	NPS	LENGTH (IN.)	HEIGHT (IN.)	WEIGHT (LB.)
33-143-01	33LF-143-01	1/2	2.97	3.47	1.00
33-144-01	33LF-144-01	3/4	3.83	4.75	1.90
33-145-01	33LF-145-01	1	4.57	5.40	2.80
33-146-01	33LF-146-01	1 1/4	5.95	7.80	7.30
33-147-01	33LF-147-01	1 1/2	5.95	7.80	6.80
33-148-01	33LF-148-01	2	7.18	8.43	10.60

*Length is measured from end-to-end.
Height is measured from centerline to top of wheel in full open position.*

STANDARDS

- MSS SP-80 Standard
- ASTM B62 Bronze (ASTM B584-C89836 Lead Free)

MODEL 120T/120T-LF
CLASS 125 NPT GLOBE VALVE



FEATURES

- Threaded Bonnet
- PTFE Disc
- 200 CWP
- 125 SWP
- Max. Temp: 406°F
- Lead Free Option (NSF 61/NSF 372)



MODEL NUMBER	LF PART NUMBER	NPS	LENGTH (IN.)	HEIGHT (IN.)	WEIGHT (LB.)
33-132-01	33LF-132-01	3/8	2.39	3.37	1.00
33-133-01	33LF-133-01	1/2	2.70	3.47	1.10
33-134-01	33LF-134-01	3/4	3.20	4.75	1.90
33-135-01	33LF-135-01	1	3.75	5.40	3.00
33-136-01	33LF-136-01	1 1/4	4.74	7.78	7.30
33-137-01	33LF-137-01	1 1/2	4.74	7.78	7.00
33-138-01	33LF-138-01	2	5.72	8.43	10.70

*Length is measured from end-to-end.
Height is measured from centerline to top of wheel in full open position.*

STANDARDS

- SS SP-80 Standard
- ASTM B62 Bronze (ASTM B584-C89836 Lead Free)

MODEL 121T/121T-LF
CLASS 125 NPT GLOBE VALVE



FEATURES

- Threaded Bonnet
- Solid Bronze Disc
- 200 CWP
- 125 SWP
- Max. Temp: 406°F
- Lead Free Option (NSF 61/NSF 372)



PART NUMBER	LF PART NUMBER	NPS	LENGTH (IN.)	HEIGHT (IN.)	WEIGHT (LB.)
33-161-01	33LF-161-01	1/4	2.39	3.46	1.00
33-162-01	33LF-162-01	3/8	2.39	3.46	1.00
33-163-01	33LF-163-01	1/2	2.70	3.56	1.10
33-164-01	33LF-164-01	3/4	3.20	4.75	1.90
33-165-01	33LF-165-01	1	3.75	5.40	3.00
33-166-01	33LF-166-01	1 1/4	4.74	7.78	7.30
33-167-01	33LF-167-01	1 1/2	4.74	7.78	7.00
33-168-01	33LF-168-01	2	5.72	8.43	11.00

*Length is measured from end-to-end.
Height is measured from centerline to top of wheel in full open position.*

STANDARDS

- MSS SP-80 Standard
- MSS SP-139 Lead Free Option (CWP only)
- ASTM B62 Bronze (ASTM B584-C89836 Lead Free)

GATE, GLOBE & CHECK VALVES



MODEL 122T
CLASS 150 NPT GLOBE VALVE

FEATURES

- Union Bonnet
- PTFE Disc
- 300 CWP
- 150 SWP
- Max. Temp: 406°F

STANDARDS

- Meets MSS SP-80 Standard
- ASTM B62 Bronze Materials



PART NUMBER	NPS	LENGTH (IN.)	HEIGHT (IN.)	WEIGHT (LB.)
33-221-01	1/4	2.39	4.23	1.40
33-222-01	3/8	2.39	4.23	1.40
33-223-01	1/2	2.70	4.31	1.40
33-224-01	3/4	3.20	4.89	2.20
33-225-01	1	3.75	5.40	3.50
33-226-01	1 1/4	4.74	7.79	7.70
33-227-01	1 1/2	4.74	7.79	7.40
33-228-01	2	5.20	8.76	12.40
33-229-01	2 1/2	6.60	10.07	18.80
33-220-01	3	7.74	11.39	25.50

Length is measured from end-to-end.

Height is measured from centerline to top of wheel in full open position.

MODEL 127T
CLASS 300 NPT GLOBE VALVE

FEATURES

- Union Bonnet
- Bronze Disc and Seat
- 1000 CWP
- 300 SWP
- Max. Temp: 406°F

STANDARDS

- Meets MSS SP-80 Standard
- ASTM B61 Bronze Materials



PART NUMBER	NPS	LENGTH (IN.)	HEIGHT (IN.)	WEIGHT (LB.)
33-663-01	1/2	2.70	5.40	1.78
33-664-01	3/4	3.20	5.86	2.28
33-665-01	1	4.00	6.71	4.22
33-666-01	1 1/4	5.25	8.50	8.30
33-667-01	1 1/2	5.25	8.50	8.10
33-668-01	2	6.25	9.75	13.00

Length is measured from end-to-end.

Height is measured from centerline to top of wheel in full open position.

MODEL 128T
CLASS 300 GLOBE VALVE

FEATURES

- Union Bonnet
- Type 420 Stainless Steel Disc and Seat Ring
- 1000 CWP
- 300 SWP
- Max. Temp: 406°F

STANDARDS

- Meets MSS SP-80 Standard
- ASTM B61 Bronze Materials



PART NUMBER	NPS	LENGTH (IN.)	HEIGHT (IN.)	WEIGHT (LB.)
33-743-01	1/2	2.70	5.40	1.78
33-744-01	3/4	3.20	5.86	2.28
33-745-01	1	4.00	6.71	4.22
33-746-01	1 1/4	5.25	8.50	8.30
33-747-01	1 1/2	5.25	8.50	8.10
33-748-01	2	6.25	9.75	13.00

Length is measured from end-to-end.

Height is measured from centerline to top of wheel in full open position.



MODEL 711F

CLASS 125 FLANGED GLOBE VALVE



PERFORMANCE RATING STANDARD

- Saturated Steam:
125 psi (8.6 Bar) at 353° F (2"-12")
- Cold Working Pressure:
200 psi (13.8 Bar) at 100° F (2"-12")
- Temperature Range: -20° to 406° F max

LEAD FREE (-LF)

- Cold Working Pressure:
200 psi (13.8 Bar) at 100° F (2"-12")
- Temperature Range: -20° to 180° F max

FEATURES

- Compatible with ANSI 125# & 150# Flanges
- Full Port
- Bronze Mounted Seat Rings
- Positive Shut-Off
- Throttling Capabilities
- Adjustable Graphite Stem Packing
- Outside Screw and Yoke
- Bolted Bonnet
- Back Seat Protection

STANDARDS

- MSS SP-85 - Gray Iron Globe and Angle Valves Flanged and Threaded Ends
- ASME B16.10 - Face-to-Face and End-to-End Dimensions of Valves

APPROVALS (LEAD FREE ONLY)

- NSF/ANSI 372 Lead Free
- NSF/AND 61 Water Quality

STANDARD PART # (STEAM RATED)	-LF PART # (NOT FOR STEAM)	-LFA PART # (STEAM RATED)	NPS	LENGTH (IN.)	HEIGHT (IN.)	WEIGHT (LB.)
6GB-118-B1	-	6GB-118-B1-LFA	2	8.00	11.61	36.0
6GB-119-B1	6GB-119-B1-LF	6GB-119-B1-LFA	2 1/2	8.50	12.99	49.0
-	-	6GB-110-B1-LFA	3	9.50	14.37	64.0
-	6GB-11A-B1-LF	6GB-11A-B1-LFA	4	11.50	15.75	94.0
6GB-11B-B1	-	6GB-11B-B1-LFA	5	13.00	17.72	137
6GB-11C-B1	6GB-11C-B1-LF	6GB-11C-B1-LFA	6	14.00	20.67	195
6GB-11E-B1	-	6GB-11E-B1-LFA	8	19.50	23.43	315
6GB-11G-B1	-	6GB-11G-B1-LFA	10	24.50	26.97	485

Length is measured from end-to-end. Height is measured from centerline to top of wheel in full open position. NOTE: Flat face mating flanges and full face gaskets must be installed to avoid damage to the cast iron body.

MODEL 721F

CLASS 250 FLANGED GLOBE VALVE



PERFORMANCE RATING STANDARD

- Saturated Steam:
125 psi (8.6 Bar) at 353° F (2"-8")
- Cold Working Pressure:
500 psi (34.4 Bar) at 100° F (2"-8")
- Temperature Range: -20° to 406° F max

LEAD FREE (-LF)

- Cold Working Pressure:
500 psi (34.4 Bar) at 100° F (2"-8")
- Temperature Range: -20° to 180° F max

FEATURES

- Compatible with ANSI 250# & 300# Flanges
- Full Port
- Bronze Mounted Seat Rings
- Positive Shut-Off
- Throttling Capabilities
- Adjustable Graphite Stem Packing
- Outside Screw and Yoke
- Flanged Connection
- Bolted Bonnet
- Rugged Iron Hand Wheel
- Back Seat Protection

STANDARDS

- MSS SP-85 - Gray Iron Globe and Angle Valves Flanged and Threaded Ends
- ASME B16.10 - Face-to-Face and End-to-End Dimensions of Valves

APPROVALS (LEAD FREE ONLY)

- NSF/ANSI 372 Lead Free
- NSF/AND 61 Water Quality

STANDARD PART # (STEAM RATED)	-LFA PART # (STEAM RATED)	NPS	LENGTH (IN.)	HEIGHT (IN.)	WEIGHT (LB.)
-	6GB-218-B1-LFA	2	10.50	14.17	40.8
6GB-219-B1	6GB-219-B1-LFA	2 1/2	11.50	15.75	52.9
6GB-210-B1	6GB-210-B1-LFA	3	12.50	16.93	70.5
6GB-21A-B1	6GB-21A-B1-LFA	4	14.00	18.90	99.2
6GB-21C-B1	6GB-21C-B1-LFA	6	17.50	23.62	203
-	6GB-21E-B1-LFA	8	21.00	27.56	333

Length is measured from end-to-end. Height is measured from centerline to top of wheel in full open position. NOTE: Class 250 flanges and flanged fittings have a 0.06 inch raised face in accordance with MSS SP-6.

MODEL 161S/161S-LF
BRONZE DISC SWING CHECK



FEATURES

- Y-Pattern
- Solder Ends
- Bronze Seat
- 200 CWP
- Lead Free Option (NSF 372)

STANDARDS

- MSS SP-80 Standard
- MSS SP-139 Lead Free Option (CWP only)
- ASTM B62 Bronze (ASTM B584-C89836 Lead Free)



MODEL NUMBER	LF MODEL NUMBER	NPS	LENGTH (IN.)	HEIGHT (IN.)	WEIGHT (LB.)
61Y-093-01	61YLF-093-01	1/2	2.53	1.65	0.62
61Y-094-01	61YLF-094-01	3/4	3.36	1.90	0.91
61Y-095-01	61YLF-095-01	1	4.07	2.26	1.70
61Y-096-01	61YLF-096-01	1 1/4	4.68	2.65	2.00
61Y-097-01	61YLF-097-01	1 1/2	5.28	2.99	2.70
61Y-098-01	61YLF-098-01	2	6.50	3.74	4.90
61Y-099-01	-	2 1/2	8.30	5.11	9.70
61Y-090-01	-	3	9.58	6.05	15.00

Height is measured from centerline to top of unit.

MODEL 161T/161T-LF
CLASS 125 BRONZE DISC SWING CHECK



FEATURES

- Y-Pattern
- NPT
- Bronze Seat
- 200 CWP
- 125 SWP
- Lead Free Option (NSF 372)

STANDARDS

- MSS SP-80 Standard
- MSS SP-139 Lead Free Option (CWP only)
- ASTM B62 Bronze (ASTM B584-C89836 Lead Free)

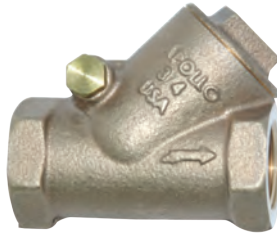

MODEL NUMBER	LF MODEL NUMBER	NPS	LENGTH (IN.)	HEIGHT (IN.)	WEIGHT (LB.)
61Y-191-01	61YLF-191-01	1/4	2.14	1.51	0.64
61Y-192-01	61YLF-192-01	3/8	2.14	1.51	0.62
61Y-193-01	61YLF-193-01	1/2	2.48	1.65	0.73
61Y-194-01	61YLF-194-01	3/4	2.94	1.90	1.06
61Y-195-01	61YLF-195-01	1	3.57	2.26	1.70
61Y-196-01	61YLF-196-01	1 1/4	4.50	2.99	3.30
61Y-197-01	61YLF-197-01	1 1/2	4.50	2.99	3.10
61Y-198-01	61YLF-198-01	2	5.25	3.74	5.50
61Y-199-01	-	2 1/2	8.00	5.11	11.70
61Y-190-01	-	3	9.24	6.05	17.80

Height is measured from centerline to top of unit.

MODEL 162T
VITON® DISC SWING CHECK

FEATURES

- Y-Pattern
- NPT
- Viton Elastomer Seat
- 200 CWP
- 125 SWP

STANDARDS

- MSS SP-80 Standard
- ASTM B62 Bronze



MODEL NUMBER	NPS	LENGTH (IN.)	HEIGHT (IN.)	WEIGHT (LB.)
61Y-201-V1	1/4	2.14	1.51	0.64
61Y-202-V1	3/8	2.14	1.51	0.62
61Y-203-V1	1/2	2.48	1.65	0.73
61Y-204-V1	3/4	2.94	1.90	1.06
61Y-205-V1	1	3.57	2.26	1.70
61Y-206-V1	1 1/4	4.50	2.99	3.30
61Y-207-V1	1 1/2	4.50	2.99	3.10
61Y-208-V1	2	5.25	3.74	5.40

Height is measured from centerline to top of unit.

MODEL 163S/163S-LF
200 CWP PTFE DISC SWING CHECK



FEATURES

- Y-Pattern
- Solder
- PTFE Soft Seat
- 200 CWP
- Lead Free Option (NSF 372)

STANDARDS

- MSS SP-80 Standard
- MSS SP-139 Lead Free Option (CWP only)
- ASTM B62 Bronze (ASTM B584-C89836 Lead Free)



PART NUMBER	LF PART NUMBER	NPS	LENGTH (IN.)	HEIGHT (IN.)	WEIGHT (LB.)
61Y-103-T1	61YLF-103-T1	1/2	2.53	1.65	0.62
61Y-104-T1	61YLF-104-T1	3/4	3.36	1.90	0.91
61Y-105-T1	61YLF-105-T1	1	4.07	2.26	1.70
61Y-106-T1	61YLF-106-T1	1 1/4	5.28	2.99	3.20
61Y-107-T1	61YLF-107-T1	1 1/2	5.28	2.99	2.70
61Y-108-T1	61YLF-108-T1	2	6.50	3.74	4.90

Height is measured from centerline to top of unit.



MODEL 163T/163T-LF
CLASS 125 PTFE DISC SWING CHECK



FEATURES

- Y-Pattern
- NPT
- PTFE Soft Seat
- 200 CWP
- 125 SWP
- Lead Free Option (NSF 372)

STANDARDS

- MSS SP-80 Standard
- MSS SP-139 Lead Free Option (CWP only)
- ASTM B62 Bronze (ASTM B584-C89836 Lead Free)

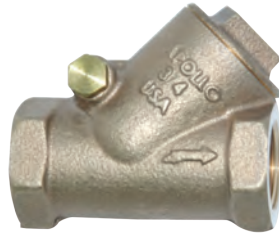

PART NUMBER	LF PART NUMBER	NPS	LENGTH (IN.)	HEIGHT (IN.)	WEIGHT (LB.)
61Y-201-T1	-	1/4	2.14	1.51	0.64
61Y-202-T1	-	3/8	2.15	1.51	0.62
61Y-203-T1	61YLF-203-T1	1/2	2.48	1.65	0.73
61Y-204-T1	61YLF-204-T1	3/4	2.94	1.90	1.06
61Y-205-T1	61YLF-205-T1	1	3.57	2.26	1.70
61Y-206-T1	61YLF-206-T1	1 1/4	4.50	2.99	3.30
61Y-207-T1	61YLF-207-T1	1 1/2	4.50	2.99	3.10
61Y-208-T1	61YLF-208-T1	2	5.25	3.74	5.40

Height is measured from centerline to top of unit.

MODEL 164T
CLASS 150 BRONZE DISC SWING CHECK

FEATURES

- Y-Pattern
- NPT
- Bronze Seat
- 300 CWP
- 150 SWP

STANDARDS

- MSS SP-80 Standard
- ASTM B62 Bronze



PART NUMBER	NPS	LENGTH (IN.)	HEIGHT (IN.)	WEIGHT (LB.)
61Y-211-01	1/4	2.14	1.51	0.64
61Y-212-01	3/8	2.14	1.51	0.62
61Y-213-01	1/2	2.48	1.65	0.73
61Y-214-01	3/4	2.94	1.90	1.06
61Y-215-01	1	3.57	2.26	1.70
61Y-216-01	1 1/4	4.50	2.99	3.30
61Y-217-01	1 1/2	4.50	2.99	3.10
61Y-218-01	2	5.25	3.74	5.50
61Y-219-01	2 1/2	8.00	5.11	11.70
61Y-210-01	3	9.24	6.05	17.80

Height is measured from centerline to top of unit.

MODEL 168T
CLASS 300 BRONZE DISC SWING CHECK

FEATURES

- Y-Pattern
- NPT
- Bronze Seat
- 600 CWP
- 300 SWP

STANDARDS

- MSS SP-80 Standard
- ASTM B61 Bronze



PART NUMBER	NPS	LENGTH (IN.)	HEIGHT (IN.)	WEIGHT (LB.)
61Y-753-01	1/2	2.50	1.65	.75
61Y-754-01	3/4	2.95	1.90	1.20
61Y-755-01	1	3.57	2.27	1.80
61Y-756-01	1 1/4	4.50	3.00	3.50
61Y-757-01	1 1/2	4.50	3.00	3.20
61Y-758-01	2	5.25	3.75	5.60

Height is measured from centerline to top of unit.

MODEL 169T
CLASS 300 PTFE DISC SWING CHECK

FEATURES

- Y-Pattern
- NPT
- PTFE Soft Seat
- 600 CWP
- 300 SWP

STANDARDS

- MSS SP-80 Standard
- ASTM B61 Bronze



PART NUMBER	NPS	LENGTH (IN.)	HEIGHT (IN.)	WEIGHT (LB.)
61Y-753-T1	1/2	2.5	1.65	.75
61Y-754-T1	3/4	2.95	1.90	1.20
61Y-755-T1	1	3.57	2.27	1.80
61Y-756-T1	1 1/4	4.50	3.00	3.50
61Y-757-T1	1 1/2	4.50	3.00	3.20
61Y-758-T1	2	5.25	3.75	5.60

Height is measured from centerline to top of unit.

MODEL 910F
CLASS 125 FLANGED SWING CHECK



PERFORMANCE RATING STANDARD

- Saturated Steam:
 - 125 psi (8.6 Bar) at 353° F (2"-12")
 - 100 psi (6.9 Bar) at 338° F (14"-20")
- Cold Working Pressure:
 - 200 psi (13.8 Bar) at 100° F (2"-12")
 - 150 psi (10.3 Bar) at 100° F (14"-20")
- Temperature Range: -20° to 406° F max

LEAD FREE (-LF)

- Cold Working Pressure:
 - 200 psi (13.8 Bar) at 100° F (2"-12")
 - 150 psi (10.3 Bar) at 100° F (14"-20")
- Temperature Range: -20° to- 180° F max

FEATURES

- Compatible with ANSI 125# & 150# Flanges
- Full Port
- Minimal Pressure Drop
- Flanged Connection
- Bolted Bonnet
- Integral Bronze Seat

APPROVALS

(LEAD FREE ONLY)

- NSF/ANSI 372 Lead Free
- NSF/AND 61 Water Quality

STANDARDS

- MSS SP-71 - Gray Iron Swing Check Valves Flanged and Threaded Ends
- ASME B16.10 - Face-to-Face and End-to-End Dimensions of Valves

STANDARD PART # (STEAM RATED)	-LF PART # (NOT FOR STEAM)	-LFA PART # (STEAM RATED)	NPS	LENGTH (IN.)	HEIGHT (IN.)	WEIGHT (LB.)
6SC-108-B1	-	6SC-108-B1-LFA	2	8.00	4.41	26.0
-	6SC-109-B1-LF	6SC-109-B1-LFA	2 1/2	8.50	5.24	39.0
-	-	6SC-100-B1-LFA	3	9.50	5.67	47.0
-	6SC-10A-B1-LF	6SC-10A-B1-LFA	4	11.50	6.61	82.0
6SC-10B-B1	-	6SC-10B-B1-LFA	5	13.00	7.80	124
6SC-10C-B1	6SC-10C-B1-LF	6SC-10C-B1-LFA	6	14.00	8.54	160
-	-	6SC-10E-01-LFA	8	19.50	10.28	271
6SC-10G-01	6SC-10G-01-LF	6SC-10G-01-LFA	10	24.50	11.30	437
6SC-10H-01	-	6SC-10H-01-LFA	12	27.50	12.56	644
6SC-10J-01	-	6SC-10J-01-LFA	14	31.00	17.50	950
6SC-10K-01	6SC-10K-01-LF	6SC-10K-01-LFA	16	36.00	23.45	1160
6SC-10M-01	-	6SC-10M-01-LFA	18	36.00	27.50	1720
6SC-10N-01	-	6SC-10N-01-LFA	20	40.00	29.25	2094

Height is measured from centerline to top of unit.

MODEL 910FLW
CLASS 125 FLANGED SWING CHECK



PERFORMANCE RATING STANDARD

- Saturated Steam:
 - 125 psi (8.6 Bar) at 353° F (2"-12")
- Cold Working Pressure:
 - 200 psi (13.8 Bar) at 100° F (2"-12")
- Temperature Range: -20° to 406° F max

LEAD FREE (-LF)

- Cold Working Pressure:
 - 200 psi (13.8 Bar) at 100° F (2"-12")
- Temperature Range: -20° to 180° F max

FEATURES

- Compatible with ANSI 125# & 150# Flanges
- Full Port
- Minimal Pressure Drop
- Flanged Connection
- Bolted Bonnet
- Integral Seat
- Lever & Weight Design

STANDARDS

- MSS SP-71 - Gray Iron Swing Check Valves Flanged and Threaded Ends
- ASME B16.10 - Face-to-Face and End-to-End Dimensions of Valves

APPROVALS

(LEAD FREE ONLY)

- NSF/ANSI 372 Lead Free
- NSF/AND 61 Water Quality

STANDARD PART # (STEAM RATED)	-LF PART # (NOT FOR STEAM)	-LFA PART # (STEAM RATED)	NPS	LENGTH (IN.)	HEIGHT (IN.)	WEIGHT (LB.)
-	6SC-108-B1L-LF	6SC-108-B1L-LFA	2	8.00	4.41	38.8
6SC-109-B1L	-	6SC-109-B1L-LFA	2 1/2	8.50	5.24	45.2
-	6SC-100-B1L-LF	6SC-100-B1L-LFA	3	9.50	5.67	61.7
-	6SC-10A-B1L-LF	6SC-10A-B1L-LFA	4	11.50	6.61	99.2
6SC-10B-B1L	6SC-10B-B1L-LF	6SC-10B-B1L-LFA	5	13.00	7.80	132
-	-	6SC-10C-B1L-LFA	6	14.00	8.54	170
-	-	6SC-10E-01L-LFA	8	19.50	10.28	282
6SC-10G-01L	-	6SC-10G-01L-LFA	10	24.50	11.30	439
6SC-10H-01L	-	6SC-10H-01L-LFA	12	27.50	12.56	672

Height is measured from centerline to top of unit.

NOTE: Flat face mating flanges and full face gaskets must be installed to avoid damage to the cast iron body.



MODEL 920F

CLASS 250 FLANGED SWING CHECK



PERFORMANCE RATING STANDARD

- Saturated Steam:
125 psi (8.6 Bar) at 353° F (2"-8")
- Cold Working Pressure:
500 psi (34.4 Bar) at 100° F (2"-8")
- Temperature Range: -20° to 406° F max

LEAD FREE (-LF)

- Cold Working Pressure:
500 psi (34.4 Bar) at 100° F (2"-8")
- Temperature Range: -20° to 180° F max

FEATURES

- Compatible with ANSI 250# & 300# Flanges
- Full Port
- Minimal Pressure Drop
- Flanged Connection
- Bolted Bonnet
- Integral Seat

STANDARDS

- MSS SP-71 - Gray Iron Swing Check Valves Flanged and Threaded Ends
- ASME B16.10 - Face-to-Face and End-to-End Dimensions of Valves
- ASME B1.1 - Unified Inch Screw Threads

APPROVALS

(LEAD FREE ONLY)

- NSF/ANSI 372 Lead Free
- NSF/AND 61 Water Quality

STANDARD PART # (STEAM RATED)	-LF PART # (NOT FOR STEAM)	-LFA PART # (STEAM RATED)	NPS	LENGTH (IN.)	HEIGHT (IN.)	WEIGHT (LB.)
6SC-208-BI	-	6SC-208-BI-LFA	2	10.51	4.41	30.0
6SC-209-BI	-	6SC-209-BI-LFA	2 1/2	11.50	5.24	44.0
6SC-200-BI	-	6SC-200-BI-LFA	3	12.50	5.67	55.0
-	-	6SC-20A-BI-LFA	4	14.00	6.61	90.0
6SC-20C-BI	6SC-20C-BI-LF	6SC-20C-BI-LFA	6	17.50	8.54	172
6SC-20E-01	-	6SC-20E-01-LFA	8	21.00	10.28	289

Height is measured from centerline to top of unit.

NOTE: Class 250 flanges and flanged fittings have a 0.06 inch raised face in accordance with MSS SP-6.



MODEL 910WB

CLASS 125 WAFER CHECK - NITRILE (BUNA-N)



FEATURES

- Compatible with ANSI 125# & 150# Flanges
- Full Port
- Minimal Pressure Drop
- Light Weight
- Spring Assisted Closing for Quicker Response

PERFORMANCE RATING

- **2"-12"**:
250 psi (17.2 Bar) Non-Shock Cold Working Pressure
Maximum Temperature to 180°F (82°C)
- **14"-24"**:
150 psi (10.3 Bar) Non-Shock Cold Working Pressure
Maximum Temperature to 180°F (82°C)
- **Not For Steam Use**

PART NUMBER	LF PART NUMBER	NPS	LENGTH (IN.)	HEIGHT (IN.)	WEIGHT (LB.)
6WC-108-NI	6WC-108-NI-LF	2	2.12	4.00	5.0
-	6WC-109-NI-LF	2 1/2	2.38	4.75	7.0
-	6WC-100-NI-LF	3	2.62	5.25	10.0
6WC-10A-NI	6WC-10A-NI-LF	4	2.62	6.75	12.0
-	6WC-10B-NI-LF	5	3.25	7.50	15.0
-	6WC-10C-NI-LF	6	3.75	8.50	22.0
-	6WC-10E-NI-LF	8	5.00	11.00	35.0
6WC-10G-NI	6WC-10G-NI-LF	10	5.50	13.25	66.0
6WC-10H-NI	6WC-10H-NI-LF	12	7.12	16.00	108
-	6WC-10J-NI-LF	14	7.25	17.75	172
-	6WC-10K-NI-LF	16	7.50	20.00	132
-	6WC-10M-NI-LF	18	8.00	21.50	223
6WC-10N-NI	6WC-10N-NI-LF	20	8.38	23.75	333
-	6WC-10P-NI-LF	24	8.75	28.00	474

MODEL 910WE

CLASS 125 WAFER CHECK - EPDM



FEATURES

- Compatible with ANSI 125# & 150# Flanges
- Full Port
- Minimal Pressure Drop
- Light Weight
- Spring Assisted Closing for Quicker Response

PERFORMANCE RATING

- Cold Working Pressure:
200 psi (13.8 Bar) at 100°F
- Temperature Range: -20°F to 180°F
- **Not For Steam Use**

APPROVALS

- CSA B51-CRN Certified

PART NUMBER	LF PART NUMBER	NPS	LENGTH (IN.)	HEIGHT (IN.)	WEIGHT (LB.)
6WC-108-EI	6WC-108-EI-LF	2	2.12	4.00	5.0
-	6WC-109-EI-LF	2 1/2	2.38	4.75	7.0
6WC-100-EI	6WC-100-EI-LF	3	2.62	5.25	10.0
-	6WC-10A-EI-LF	4	2.62	6.75	12.0
6WC-10B-EI	6WC-10B-EI-LF	5	3.25	7.50	15.0
-	6WC-10C-EI-LF	6	3.75	8.50	22.0
-	6WC-10E-EI-LF	8	5.00	11.00	35.0
6WC-10G-EI	6WC-10G-EI-LF	10	5.50	13.25	66.0
-	6WC-10H-EI-LF	12	7.12	16.00	108



CV COEFFICIENTS
FOR FLOW ESTIMATION ONLY

SIZE	BRONZE GATE	BRONZE GLOBE	BRONZE SWING CHECK	CI GATE	CI GLOBE	CI SWING CHECK	CI WAFER CHECK
1/4	3.0	1.4	2.6	-	-	-	-
3/8	6.0	2.6	4.5	-	-	-	-
1/2	12.5	4.4	7.0	-	-	-	-
3/4	24.0	7.4	12.0	-	-	-	-
1	72.3	12.1	28.6	-	-	-	-
1-1/4	80	29	39	-	-	-	-
1-1/2	119	30	56	-	-	-	-
2	338	49	152	328	52	132	75
2-1/2	395	74	198	482	76	192	95
3	435	112	242	744	116	298	191
4	-	-	-	1316	204	526	377
5	-	-	-	2130	328	852	483
6	-	-	-	3176	488	1272	821
8	-	-	-	5692	874	2278	1590
10	-	-	-	8972	1376	3588	2920
12	-	-	-	13352	-	5342	4470
14	-	-	-	16278	-	6512	5870
16	-	-	-	21564	-	8626	8690
18	-	-	-	28716	-	11488	10940
20	-	-	-	35762	-	14304	14290
24	-	-	-	52166	-	-	23000



**BRONZE GATE VALVE
CROSS REFERENCE CHART**

APOLLO MODEL	101S	101S-LF	101T	101T-LF	102S	102S-LF
APOLLO P/N	30-08X-01	30LF-08X-01	30-00X-01	30LF-00X-01	30-04X-01	30LF-04X-01
SIZE RANGE	1/2" TO 3"	1/2" TO 3"	1/4" TO 3"	1/4" TO 3"	1/2" TO 3"	1/2" TO 3"
DESCRIPTION	200 CWP Gate Valve Bronze Threaded Bonnet Solid Disc Rising Stem Solder Ends	200 CWP Gate Valve LF-Bronze Threaded Bonnet Solid Disc Rising Stem Solder Ends	Class 125 (200 CWP, 125 SWP) Gate Valve Bronze Threaded Bonnet Solid Disc Rising Stem NPT	Class 125 (200 CWP, 125 SWP) Gate Valve LF-Bronze Threaded Bonnet Solid Disc Rising Stem NPT	200 CWP Gate Valve Bronze Threaded Bonnet Solid Disc NRS Solder Ends	200 CWP Gate Valve LF-Bronze Threaded Bonnet Solid Disc NRS Solder Ends
DESIGN STANDARD	MSS SP-80	MSS SP-139 MSS SP-80	MSS SP-80	MSS SP-139 MSS SP-80	MSS SP-80	MSS SP-139 MSS SP-80
CRANE MODEL	1334		428		1320	
HAMMOND MODEL	IB635		IB640	UP640	IB647	
KITZ MODEL	444		24		41	
MILWAUKEE MODEL	149	UP149	148	UP148	115	UP115
NIBCO MODEL	S111		T111		S113	S113-LF
STOCKHAM MODEL	B108K		B100K		B104K	
WALWORTH MODEL	55SJ		55		4SJ	

APOLLO MODEL	102T	102T-LF	102T-K	103T	106T	107T	111T	116T
APOLLO P/N	30-03X-01	30LF-03X-01	30-03X-01K	30-05X-01	30-28X-01	30-20X-01	30-44X-01	30-45X-01
SIZE RANGE	1/4" TO 3"	1/4" TO 3"	1/4" TO 3"	1/4" TO 3"	1/4" TO 3"	1/4" TO 3"	1/2" TO 2"	1/2" TO 2"
DESCRIPTION	Class 125 (200 CWP, 125 SWP) Gate Valve Bronze Threaded Bonnet Solid Disc NRS NPT	Class 125 (200 CWP, 125 SWP) Gate Valve LF-Bronze Threaded Bonnet Solid Disc NRS NPT	Class 125 (200 CWP, 125 SWP) Gate Valve Bronze Threaded Bonnet Solid Disc NRS NPT	Class 125 (200 CWP, 125 SWP) Gate Valve Bronze Union Bonnet Solid Disc Rising Stem NPT	Class 150 (300 CWP, 150 SWP) Gate Valve Bronze Threaded Bonnet Solid Disc NRS NPT	Class 150 (300 CWP, 150 SWP) Gate Valve Bronze Union Bonnet Solid Disc Rising Stem NPT	Class 300 (1000 CWP, 300 SWP) Gate Valve Bronze Union Bonnet Solid Disc Rising Stem NPT	Class 300 (1000 CWP, 300 SWP) Gate Valve Bronze Union Bonnet Solid Disc, SS Seats Rising Stem NPT
DESIGN STANDARD	MSS SP-80	MSS SP-139 MSS SP-80	MSS SP-80	MSS SP-80	MSS SP-80	MSS SP-80	MSS SP-80	MSS SP-80
CRANE MODEL	438			428UB	437	431UB	622E	634E
HAMMOND MODEL	IB645			IB617	IB646	IB629	IB652	IB654
KITZ MODEL	40				46	42	37	
MILWAUKEE MODEL	105	UP105		1152	1140	1151	1182	1184
NIBCO MODEL	T113	T113-LF	T113-K	T124	T133	T134	T174A	T174SS
STOCKHAM MODEL	B103K			B105K	B128K	B120K	B144K	B145K
WALWORTH MODEL	4			2	14	11	3048	

GATE, GLOBE & CHECK VALVES



**BRONZE CHECK VALVE
CROSS REFERENCE CHART**

APOLLO MODEL	161S	161S-LF	161T	161T-LF	162T
APOLLO P/N	61Y-09X-01	61YLF-09X-01	61Y-19X-01	61YLF-19X-01	61Y-20X-VI
SIZE RANGE	1/2" to 3"	1/2" to 2"	1/4" to 3"	1/4" to 2"	1/4" to 2"
DESCRIPTION	200 CWP Swing Check Bronze Y-Pattern Bronze Disc Solder Ends	200 CWP Swing Check LF-Bronze Y-Pattern Bronze Disc Solder Ends	Class 125 (200 CWP, 125 SWP) Swing Check Bronze Y-Pattern Bronze Disc NPT	Class 125 (200 CWP, 125 SWP) Swing Check LF-Bronze Y-Pattern Bronze Disc NPT	Class 125 (200 CWP, 125 SWP) Swing Check Bronze Y-Pattern Viton® Disc NPT
DESIGN STANDARD	MSS SP-80	MSS SP-139	MSS SP-80	MSS SP-139	MSS SP-80
CRANE MODEL	1340		37		
HAMMOND MODEL	IB912		IB904		
KITZ MODEL			22		
MILWAUKEE MODEL	1509	UP1509	509	UP509	
NIBCO MODEL	S413B		T413B		T413V
STOCKHAM MODEL	B309YK		B319YK		B320BYK
WALWORTH MODEL	3406SJ		3406		

APOLLO MODEL	163S	163S-LF	163T	163T-LF	164T	168T	169T
APOLLO P/N	61Y-10X-T1	61YLF-10X-T1	61Y-20X-T1	61YLF-20X-T1	61Y-21X-01	61Y-75X-01	61Y-75X-T1
SIZE RANGE	1/2" to 2"	1/2" to 2"	1/4" to 2"	1/2" to 2"	1/4" to 3"	1/2" to 2"	1/2" to 2"
DESCRIPTION	200 CWP Swing Check Bronze Y-Pattern PTFE Disc Solder Ends	200 CWP Swing Check LF-Bronze Y-Pattern PTFE Disc Solder Ends	Class 125 (200 CWP, 125 SWP) Swing Check Bronze Y-Pattern PTFE Disc NPT	Class 125 (200 CWP, 125 SWP) Swing Check LF-Bronze Y-Pattern PTFE Disc NPT	Class 150 (300 CWP, 150 SWP) Swing Check Bronze Y-Pattern Bronze Disc NPT	Class 300 (600 CWP, 300 SWP) Swing Check Bronze Y-Pattern Bronze Disc NPT	Class 300 (600 CWP, 300 SWP) Swing Check Bronze Y-Pattern PTFE Disc NPT
DESIGN STANDARD	MSS SP-80	MSS SP-139	MSS SP-80	MSS SP-139	MSS SP-80	MSS SP-80	MSS SP-80
CRANE MODEL			41TF		137	76E	
HAMMOND MODEL	IB423		IB940			IB949	
KITZ MODEL	23T	823T	22T	822T	29	19	
MILWAUKEE MODEL	1509T		509T		510	507	
NIBCO MODEL	S413Y	S413Y-LF	T413Y	T413Y-LF	T433b	T473B	T473Y
STOCKHAM MODEL	B310TY		B320TYK		B321K	B375K	
WALWORTH MODEL	3095SJ					3428	

GATE, GLOBE & CHECK VALVES



**BRONZE GLOBE VALVE
CROSS REFERENCE CHART**

APOLLO MODEL	120S	120S-LF	120T	120T-LF	121T	121T-LF	122T	127T	128T
APOLLO P/N	33-14X-01	33LF-14X-01	33-13X-01	33LF-13X-01	33-16X-01	33LF-16X-01	33-22X-01	33-66X-01	33-74X-01
SIZE RANGE	1/2" to 2"	1/2" to 2"	3/8" to 2"	3/8" to 2"	1/4" to 2"	1/4" to 2"	1/4" to 3"	1/2" to 2"	1/2" to 2"
DESCRIPTION	200 CWP Globe Valve Bronze Threaded Bonnet PTFE Disc Solder Ends	200 CWP Globe Valve LF-Bronze Threaded Bonnet PTFE Disc Solder Ends	Class 125 (200 CWP, 125 SWP) Globe Valve Bronze Threaded Bonnet PTFE Disc NPT	Class 125 (200 CWP, 125 SWP) Globe Valve LF-Bronze Threaded Bonnet PTFE Disc NPT	Class 125 (200 CWP, 125 SWP) Globe Valve Bronze Threaded Bonnet Bronze Disc NPT	Class 125 (200 CWP, 125 SWP) Globe Valve LF-Bronze Threaded Bonnet Bronze Disc NPT	Class 150 (300 CWP, 150 SWP) Globe Valve Bronze Union Bonnet PTFE Disc NPT	Class 300 (1000 CWP, 300 SWP) Globe Valve Bronze Union Bonnet Bronze Disc NPT	Class 300 (1000 CWP, 300 SWP) Globe Valve Bronze Union Bonnet SS Disc NPT
DESIGN STANDARD	MSS SP-80	MSS SP-80	MSS SP-80	MSS SP-139	MSS SP-80	MSS SP-139 MSS SP-80	MSS SP-80	MSS SP-80	MSS SP-80
CRANE MODEL			5TF		1		7TF		382P
HAMMOND MODEL					IB440		IB413T	IB412	IB444
KITZ MODEL					11		9	17	17S
MILWAUKEE MODEL		UP1502			502	UP502	590T	572	593A
NIBCO MODEL	S211Y		T211Y		T211b		T235Y	T275B	T276-AP
STOCKHAM MODEL	B14TK		B13TK		B16K		B22TK	B66K	B74K
WALWORTH MODEL	3095SJ				3058		3095	3205	

**IRON GLOBE VALVE
CROSS REFERENCE CHART**

APOLLO MODEL	711F	721F
APOLLO P/N	6GB-11X-B1	6GB-21X-B1
SIZE RANGE	2" to 10"	2" to 8"
DESCRIPTION	Class 125 Flanged Globe Valve Cast Iron OS&Y IBBM	Class 250 Flanged Globe Valve Cast Iron OS&Y IBBM
DESIGN STANDARD	MSS SP-85	MSS SP-85
CRANE MODEL	351	21E
HAMMOND MODEL	IR116	IR313
KITZ MODEL		
MILWAUKEE MODEL	2981M	2983M
NIBCO MODEL	F718B	F768B
STOCKHAM MODEL	G512	F532
WALWORTH MODEL	W906F	W955F

GATE, GLOBE & CHECK VALVES



IRON GATE VALVE
CROSS REFERENCE CHART

APOLLO MODEL	610F	620F	611F	621F
APOLLO P/N	6GA-10X-B1	6GA-20X-B1	6GA-11X-B1	6GA-21X-B1
SIZE RANGE	2" to 24"	2" to 12"	2" to 24"	2" to 12"
DESCRIPTION	Class 125 Flanged Gate Valve Cast Iron NRS IBBM	Class 250 Flanged Gate Valve Cast Iron NRS IBBM	Class 125 Flanged Gate Valve Cast Iron OS&Y IBBM	Class 250 Flanged Gate Valve Cast Iron OS&Y IBBM
DESIGN STANDARD	MSS SP-70	MSS SP-70	MSS SP-70	MSS SP-70
CRANE MODEL	461		465 1/2	7 1/2E
HAMMOND MODEL	IR1138		IR1140	IR330
KITZ MODEL				
MILWAUKEE MODEL	2882M		2885M	2894M
NIBCO MODEL	F619	F669	F617-0	F667-0
STOCKHAM MODEL	G612	F661	G623	F667
WALWORTH MODEL	W719F		W726F	W786F

IRON CHECK VALVE
CROSS REFERENCE CHART

APOLLO MODEL	910F	910FLW	920F	910WB	910WE
APOLLO P/N	6SC-10X-B1	6SC-10X-B1L	6SC-20X-B1	6WC-10X-N1	6WC-10X-E1
SIZE RANGE	2" to 24"	2" to 12"	2" to 8"	2" to 24"	2" to 12"
DESCRIPTION	Class 125 Flanged Swing Check Cast Iron IBBM	Class 125 Flanged Swing Check Cast Iron IBBM w/ lever & weight	Class 250 Flanged Swing Check Cast Iron IBBM	Class 125 Wafer Check Buna Cast Iron IBBM	Class 125 Wafer Check EPDM Cast Iron IBBM
DESIGN STANDARD	MSS SP-71	MSS SP-71	MSS SP-71		
CRANE MODEL	373	383	39E		
HAMMOND MODEL	IR1124		IR322	IR9253	
KITZ MODEL					
MILWAUKEE MODEL	2974M	C2974MLW	2970M	1400	
NIBCO MODEL	F918B	F918BLW	F968B	W910B	
STOCKHAM MODEL	G931	G931W	F947	WG970	WG961
WALWORTH MODEL	W928F		W8970F		

GATE, GLOBE,
& CHECK VALVES



STANDARDS (GATE, GLOBE, SWING & WAFER CHECKS ONLY)

BRONZE STANDARDS COMPLIANCE:

ASME B1.20.1 - Pipe Threads, General Purpose (Inch)
 ASME B16.18 - Cast Copper Solder Joint Pressure Fittings
 ASTM B61 - Standard Specification for Steam or Valve Bronze Castings
 ASTM B62 - Composition Bronze or Ounce Metal Castings
 ASTM B371 - Standard Specification for Copper-Zinc-Silicon Alloy Rod
 ASTM B584 - Standard Specification for Copper Alloy Sand Castings for General Applications*
 MSS SP-25 - Standard Marking System for Valves, Fittings and Flanges
 MSS SP-80 - Bronze Gate, Globe, Angle and Check Valves
 MSS SP-139 - Copper Alloy Globe, Angle, and Check Valves for Low Pressure/Low Temperature Plumbing Applications*
 CRN-OC14467.5C (gates and globes) and CRN-OC11218.5C (swing checks) (see www.apollovalves.com for specific provinces)
 Canadian Registration Number in accordance with CSA B51 Boiler, Pressure Vessel and Pressure Piping Code
 NSF/ANSI 61 Water Quality, 3rd party certified (lead free versions only)
 NSF/ANSI 372 Lead Free, 3rd party certified (lead free versions only)

CAST IRON STANDARDS COMPLIANCE:

ASME B16.1 - Cast Iron Pipe Flanges and Flanged Fittings (Class 125 - flat faced flanged, Class 250 - 0.06 inch raised faced in accordance with MSS SP-6)
 ASME B16.10 - Face-to-Face and End-to-End Dimensions of Valves
 ASME A126 - Specification for Gray Iron Castings for Valves, Flanges and Pipe Fittings
 ASTM A307 - Specification for Carbon Steel Bolts and Studs, 60000 psi Tensile Strength
 MSS SP-25 - Standard Marking System for Valves, Fittings and Flanges and Unions
 MSS SP-70 - Gray Iron Gate Valves Flanged and Threaded Ends
 MSS SP-71 - Gray Iron Swing Check Valves Flanged and Threaded Ends
 MSS SP-85 - Gray Iron Globe and Angle Valves Flanged and Threaded Ends
 CRN-OC14467.xx (see www.apollovalves.com for specific provinces)
 Canadian Registration Number in accordance with CSA B51 Boiler, Pressure Vessel and Pressure Piping Code.
 NSF/ANSI 61 Water Quality, 3rd party certified (lead free versions only)
 NSF/ANSI 372 Lead Free, 3rd party certified (lead free versions only)

CAUTIONS:

Bubble tight shut-off should not be expected on metal seated check valves. MSS Standards for Bronze (MSS SP-80) and for Cast Iron (MSS SP-71) define acceptable leakage rates as 40 ml of water per hour per inch of Nominal Pipe Size (NPS) for valves 1" and larger or 0.4 Standard Cubic Foot (SCF) air per hour per inch of NPS. For valves smaller than 1" the allowable leak rate is 40 ml of water per hour or 0.4 SCF of air per hour.

Bubble tight shut-off should not be expected on metal to metal seated gate or globe valves. MSS Standards for Bronze (MSS SP-80) and for Cast Iron (MSS SP-70 and MSS SP-85) define acceptable leakage rates as 10 ml of water per hour per inch of Nominal Pipe Size (NPS) for valves 1" and larger or 0.1 SCF of air per hour per inch of NPS. For valves smaller than 1" the allowable leak rate is 10 ml of water per hour or 0.1 SCF of air per hour.

Gate valves are not recommended for throttling service and should only be used in the fully open or fully closed positions to minimize vibration and chatter which may damage the seat or wedge. For throttling applications refer to Apollo's globe valve offering.

Safe working pressures and temperatures for solder end valve depends not only on the valve and tubing strength, but also on the composition of the solder used to produce the joints. It is the responsibility of the user to choose a solder that is compatible with the service conditions.

Properly sized swing check valves frequently are smaller than the pipe in which they are used. This practice keeps velocities up so the valve operates near full open, minimizing noise and vibration while maximizing valve life.



IN-LINE CHECK VALVES

Series 61 and lead free (61LF) check valves feature bronze body construction and are available in sizes 1/4" to 3" for use with water, steam, oil, air and inert gases. Series 62 model in stainless steel with investment cast body are sized from 1/4" to 2" for use in more severe applications and corrosive environments.

61 and 62 Series check valves are available with either RPTFE ball cone or elastomer soft seats. They come equipped with 316 stainless steel springs. All wetted parts are bronze/brass (61 Series) or stainless steel (62 Series).

SPRING ASSISTED CLOSING

Apollo's 61 and 62 Series feature short check travel and spring assisted closing. This ensures the valve closes quickly, before reversal of flow, helping to eliminate water hammer, its associated noise, and damage to piping and machinery.

LOW CRACKING PRESSURE

Apollo's standard 61 and 62 Series checks operate at a low 1/2 psi cracking pressure. An extra-light-spring version of the valve is available as an option. A 5-pound or 10-pound cracking pressure spring is also available on models through 1".

TIGHT...OR BUBBLE TIGHT

Patented Apollo® Ball Cone® check valves (61-100, 61-200 and 62-100) feature a tight-sealing RPTFE ball-shaped check which seats against the conical interior face of the valve's metal retainer. This simple design provides exceptional resistance to wear and corrosion. But, where even tighter sealing is required, choose the 61-500 or 61-600, featuring EPDM (elastomer) seat or 62-500, featuring a Fluorocarbon (Viton®) seat, for a bubble-tight seal. A Nitrile seat is optional.

CHECK VALVES EXTEND SYSTEM LIFE

In any liquid or gas system where reverse flow cannot be tolerated, a quick-responding check valve is a necessity. Check valves that close slowly permit flow reversal to occur in the line which can cause severe mechanical shock. As the valve finally seats, high peak pressure pulses and shock waves are generated on the downstream side due to the media being forced to a sudden stop. Upstream, the momentum is not restricted which can create voids in the flow, filling with air or vapor to cause additional, lower frequency shock waves. These shock waves added together are known as water hammer. It can cause extensive damage or failure to pipelines, gaskets, supports, hardware and equipment. The result can be expensive, troublesome; even dangerous.

With Apollo® check valves, the potential for water hammer is greatly reduced since the check returns to its seat before flow velocity reaches zero. Apollo's check valves set the standard for compact, economical protection against reverse flow. They provide reliable service in liquids or gases at various temperature and pressure combinations. Because of their simple design, they're versatile and easy to maintain.

USE IN ANY POSITION

Horizontal, vertical or upside down; liquid, air and gases; Apollo's in-line checks operate in any orientation. Where frequent opening and closing cycles occur, vertical orientation with upward flow is best. This saves time and money, eliminating the need to stock separate vertical and horizontal-operating valves. It also makes new or replacement installation less of a headache.

*Not recommended for use with reciprocating pumps and similar applications. Low flows may result in undesirable noise and premature valve failure.

BROAD RANGE OF APPLICATIONS

Apollo® check valves are at home in applications from residential boilers to tough process systems, including:

Industries where Apollo's check valves are used include Pulp & Paper, Chemical Processing, Agrichemical, Rubber, Petroleum, Primary Metals, Mining, Power Generation, Textiles, Food and Beverage, Building Construction and Maintenance.

- Evaporators
- Boiler Feed
- Water Lines
- Steam Lines
- Cookers
- Chiller Systems
- Steam Tracer Lines
- Salt Water Injection
- Rubber/Plastic Presses
- Autoclaves
- Sterilizers
- Air and Gas Lines
- Metering Pumps
- Casing Vents
- Condensate Return Lines
- Chemical Lines

GATE, GLOBE & CHECK VALVES



**CVB (61-100 & 61-200) SERIES
IN-LINE BALL CONE® CHECK VALVE**



**61-100
FEMALE X FEMALE THREADED
1/4" THROUGH 3"**



**61-200
MALE X FEMALE THREADED
1/4" THROUGH 2"**

The Apollo® Model CVB check valve with rugged bronze body and patented design (U.S. Pat. No. 4,172,465) RPTFE ball-cone check provides reliable protection against reverse flow. It is spring-loaded for fast seating and center guided for optimum alignment.

FEATURES

- Standard 1/2 psi Cracking Pressure
- Tight Shut-Off with Liquid Media
- Male and Female NPT Inlet Options
- 400 psig CWP @ 100°F
- 125 psig Steam Rating @ 350°F max
- Straight-Through Flow Minimizes Pressure Loss
- ASTM B584 Bronze
- Lead Free Option 61LF (NSF 61/NSF 372)
- **MADE IN USA**

DIMENSIONS

BRONZE FNPT X FNPT	LF BRONZE FNPT X FNPT	BRONZE MNPT X FNPT	SIZE	DIMENSIONS (IN.)			61-100 SERIES WT./100	61-200 SERIES WT./100
				A	B	C		
61-101-01	61LF-101-01	61-201-01	1/4"	2.06	1.12	1.12	38	38
61-102-01	61LF-102-01	61-202-01	3/8"	2.12	1.12	1.12	37	37
61-103-01	61LF-103-01	61-203-01	1/2"	2.31	1.12	1.12	36	36
61-104-01	61LF-104-01	61-204-01	3/4"	2.87	1.37	1.50	75	76
61-105-01	61LF-105-01	61-205-01	1"	3.50	1.75	1.93	145	145
61-106-01	61LF-106-01	61-206-01	1-1/4"	4.18	2.12	2.37	275	237
61-107-01	61LF-107-01	61-207-01	1-1/2"	4.93	2.50	2.81	394	381
61-108-01	61LF-108-01	61-208-01	2"	6.00	3.00	3.68	630	636
61-109-01	61LF-109-01	-	2-1/2"	7.00	3.50	4.50	1400	-
61-100-01	61LF-100-01	-	3"	8.12	4.12	5.31	1665	-

STANDARD MATERIALS LIST

BODY	Bronze, ASTM B584, UNS C84400 or Lead Free Bronze, C89836
RETAINER	(1/4" - 1") Brass, ASTM B16 or C27451 (1-1/4" - 3") Bronze, ASTM B584 or C89836
BALL CHECK	RPTFE
GUIDE	Brass, ASTM B16 or LF Brass, C27451
SPRING	Stainless Steel

FLOW RATE (C_v)

SIZE	GPM
1/4"	0.85
3/8"	1.21
1/2"	1.4
3/4"	3.53
1"	6
1-1/4"	44
1-1/2"	65
2"	81
2-1/2"	175
3"	265

PRESSURE TEMPERATURE RATING

DEGREE (F)	PSIG
-20 TO 100	400
200	200
250	160
275	150
300	140
325	130
353	125

GPM=gallons per minute at 1 psi pressure differential

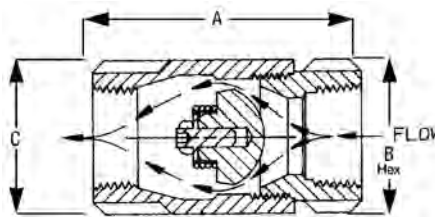

61-100

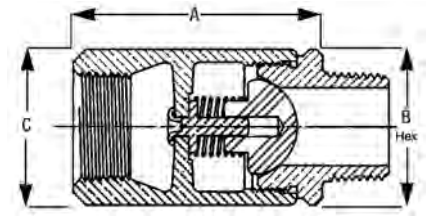

61-200

NOTE: Not recommended for use with reciprocating pumps and similar applications. Low flows may result in undesirable noise and premature valve failure.

PART NO. MATRIX

6 x	- X	X	X	- XX
TYPE	CHECK	SPRING TYPE	SIZE (IN.)	OPTIONS
1 - BRONZE	1 - BALL CONE (NPT-F X F)	0 - .5 PSIG CRACKING PRESSURE	1 - 1/4"	01 - STANDARD
1LF - LEAD FREE BRONZE	2 - BALL CONE (NPT-M X F)	2 - .2 PSIG CRACKING PRESSURE	2 - 3/8"	PO1 - BSPP THREAD**
2 - STAINLESS STEEL	0 - BALL CONE REPAIR KIT		3 - 1/2"	TO1 - BSPT THREAD**
			4 - 3/4"	17 - SATIN CHROME PLATED
			5 - 1"	57 - OXYGEN CLEANED
			6 - 1-1/4"	A1 - LESS SPRING
			7 - 1-1/2"	E05 - 5 PSIG OPENING PRESSURE*
			8 - 2"	E10 - 10 PSIG OPENING PRESSURE*
			9 - 2-1/2"	
			0 - 3"	

*Available in 1/4" through 1" only. | **Minimums apply
(Note: Not all combinations are available. Contact Customer Service for verification.)



CVS (62-100) SERIES

STAINLESS STEEL BALL CONE® CHECK VALVE



62-100
FEMALE X FEMALE THREADED
1/4" THROUGH 2"

The Apollo® Model CVS is uniquely suited for applications in corrosive environments, including chemical processing, pulp and paper and other process industries. The rugged stainless steel body and RPTFE ball cone check provide reliable, patented protection against reverse flow.

FEATURES

- Standard 1/2 psi Cracking Pressure
- Unique Design (U.S. Patent # 4,172,465)
- Spring-Loaded For Fast Seating Action
- Center Guided; Radial Alignment Never Needed
- Straight-Through Flow Minimizes Pressure Loss
- 400 psig CWP Non-Shock @ 100°F
- 125 psig SWP @ 350°F
- RoHS Compliant
- ASTM A351, CF8M

STANDARD MATERIALS LIST

BODY	SS, ASTM A351, CF8M
RETAINER	SS, ASTM A276, 316 (1/4" - 1") SS, ASTM A351, CF8M (1-1/4" - 2")
BALL CHECK	RPTFE
GUIDE	SS, ASTM A276, 316
SPRING	Stainless Steel

DIMENSIONS

PART NO. FNPT X FNPT	SIZE	DIMENSIONS (IN.)			WT./100
		A	B	C	
62-101-01	1/4"	2.06	1.12	1.12	38
62-102-01	3/8"	2.12	1.12	1.12	37
62-103-01	1/2"	2.31	1.12	1.12	36
62-104-01	3/4"	2.87	1.37	1.50	75
62-105-01	1"	3.50	1.75	1.93	145
62-106-01	1-1/4"	4.18	2.12	2.37	237
62-107-01	1-1/2"	4.93	2.50	2.81	381
62-108-01	2"	6.00	3.00	3.68	636

FLOW RATE (C_v)

SIZE	GPM
1/4"	0.85
3/8"	1.21
1/2"	1.4
3/4"	3.53
1"	6
1-1/4"	44
1-1/2"	65
2"	81

GPM=gallons per minute at 1 psi pressure differential

PRESSURE TEMPERATURE RATING

DEGREE (F)	PSIG
-20 TO 100	400
200	200
250	160
275	150
300	140
325	130
353	125

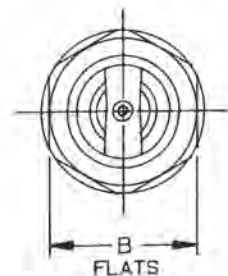
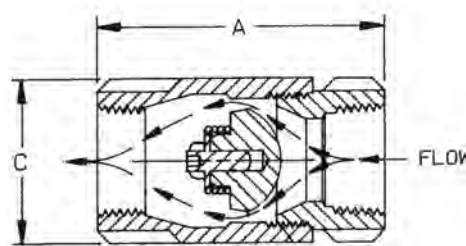

NOTE: Not recommended for use with reciprocating pumps and similar applications. Low flows may result in undesirable noise and premature valve failure.

PART NO. MATRIX

62	- X	X	X	- XX
TYPE	CHECK	SPRING TYPE	SIZE (IN.)	OPTIONS
62 - STAINLESS STEEL	1 - BALL CONE (NPT-F X F)	0 - .5 PSIG CRACKING PRESSURE	1 - 1/4"	01 - STANDARD
	2 - BALL CONE (NPT-M X F)	2 - .2 PSIG CRACKING PRESSURE	2 - 3/8"	P01 - BSPP THREAD**
	0 - BALL CONE REPAIR KIT		3 - 1/2"	T01 - BSPT THREAD**
			4 - 3/4"	17 - SATIN CHROME PLATED
			5 - 1"	57 - OXYGEN CLEANED
			6 - 1-1/4"	A1 - LESS SPRING
			7 - 1-1/2"	E05 - 5 PSIG OPENING PRESSURE*
			8 - 2"	E10 - 10 PSIG OPENING PRESSURE*
			9 - 2-1/2"	
			0 - 3"	

*Available in 1/4" through 1" only.

**Minimums apply

(Note: Not all combinations are available. Contact Customer Service for verification.)



**CVBE (61-500 & 61-600) SERIES
IN-LINE SOFT SEAT CHECK VALVE**



**61-500
FEMALE X FEMALE THREADED
1/4" THROUGH 2"**



**61-600
FEMALE X FEMALE SWEAT
1/2" THROUGH 2"**



The Apollo® Model CVBE check valve is ideally suited for hydronic heating and other low flow applications. The rugged bronze body and check provide reliable protection against reverse flow.

FEATURES

- Female NPT Sizes: 1/4" to 2"
- Stainless Steel Sizes: 1/4" to 1" (62-500)
- Bubble-Tight Shut-Off, Ideally Suited for Gaseous Service
- NPT Threaded; 400 psig CWP Non-Shock @ 100°F

- EPDM Check Disc (61-500)
- Viton® Check Disc (62-500)
- Straight-Through Flow Minimizes Pressure Loss
- 1/2 psi Cracking Pressure
- RoHS Compliant (61LF and 62 Series)
- NSF/ANSI 61 Water Quality (Lead Free Models)
- NSF/ANSI 372 Lead Free (Lead Free Models)

STANDARD MATERIALS LIST

BODY	Bronze, ASTM B584, UNS C84400 or Lead Free Bronze, C89836
RETAINER	(1/4" - 1") Brass, ASTM B16 or C27451 (1-1/4" - 3") Bronze, ASTM B584 or C89836
SEAT	EPDM
GUIDE PIN	Stainless Steel
SPRING	Stainless Steel
CHECK	Brass, ASTM B16
GUIDE	Brass, ASTM B16

FLOW RATE (C_v)

SIZE	GPM	
	61-500	61-600
1/4"	0.85	-
3/8"	1.21	-
1/2"	1.4	2.20
3/4"	3.53	4.78
1"	6	6
1-1/4"	44	44
1-1/2"	65	65
2"	81	81

GPM=gallons per minute at 1 psi pressure differential

DIMENSIONS

PART NO.	LF PART NO.	SIZE	DIMENSIONS (IN.)			WT./100
			A	B	C	
61-500 (FNPT)						
61-501-01	61LF-501-01	1/4"	2.31	1.12	1.12	38
61-502-01	61LF-502-01	3/8"	2.31	1.12	1.12	37
61-503-01	61LF-503-01	1/2"	2.31	1.12	1.12	36
61-504-01	61LF-504-01	3/4"	2.87	1.37	1.50	75
61-505-01	61LF-505-01	1"	3.50	1.75	1.93	145
61-506-01	61LF-506-01	1-1/4"	4.18	2.12	2.37	275
61-507-01	61LF-507-01	1-1/2"	4.93	2.50	2.81	394
61-508-01	61LF-508-01	2"	6.00	3.00	3.68	630
61-600 (SOLDER)						
61-603-01	61LF-603-01	1/2"	2.75	1.12	1.25	38
61-604-01	61LF-604-01	3/4"	3.68	1.50	1.62	75
61-605-01	61LF-605-01	1"	4.50	1.93	2.12	145
61-606-01	61LF-606-01	1-1/4"	6.11	2.13	2.38	330
61-607-01	61LF-607-01	1-1/2"	6.87	2.50	2.81	610
61-608-01	61LF-608-01	2"	7.46	3.38	3.75	1010

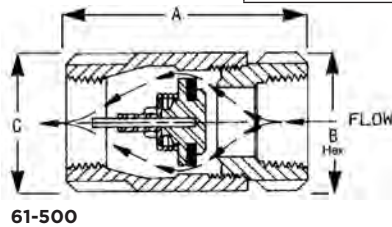

61-500

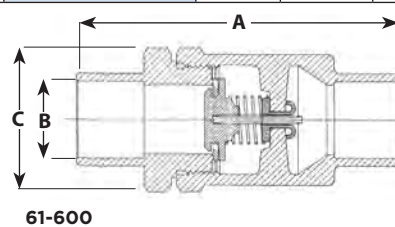

61-600

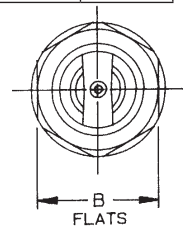

B FLATS

NOTE: Not recommended for use with reciprocating pumps and similar applications. Low flows may result in undesirable noise and premature valve failure.

PART NO. MATRIX

61 xx	- X	X	X	- XX
TYPE	CHECK	SPRING TYPE	SIZE (IN.)	OPTIONS
61 - BRONZE	5 - SOFT SEAT (NPT-F X F)	0 - .5 PSIG CRACKING PRESSURE	1 - 1/4"	01 - STANDARD (EPDM SEAT)
61LF - LEAD FREE BRONZE	6 - SOFT SEAT (SOLDER)	2 - .2 PSIG CRACKING PRESSURE	2 - 3/8"	PO1 - BSPPT THREAD (ISO 228)**
	9 - SOFT SEAT REPAIR KIT (EPR ONLY)		3 - 1/2"	TO1 - BSPT THREAD (EN 10226)**
			4 - 3/4"	17 - SATIN CHROME PLATED
			5 - 1"	57 - OXYGEN CLEANED
				A1 - LESS SPRING
				BI - NITRILE SEAT
				VI - VITON SEAT
				E05 - 5 PSIG OPENING PRESSURE*
				E10 - 10 PSIG OPENING PRESSURE*

*Available in 1/4" through 1" only. | **Minimums apply (Note: Not all combinations are available. Contact Customer Service for verification.)



CVSE (62-500) SERIES
IN-LINE SOFT SEAT CHECK VALVE



62-500
FEMALE X FEMALE THREADED
1/4" THROUGH 1"

The Apollo® Model CVSE is ideal for fluid flow applications in tough industrial environments. The stainless steel body and check provide lasting protection against reverse flow.

FEATURES

- Bubble-Tight Shut-Off, Ideally Suited for Gaseous Service
- 400 psig CWP non-shock
- Viton® Check Disc
- Approximate Opening Pressure 1/2 psi
- RoHS Compliant
- CRN OC 11218.5C

STANDARD MATERIALS LIST

BODY	Stainless Steel, ASTM A351,CF8M
RETAINER	Stainless Steel, ASTM A276, 316
SEAT	Viton®
SPRING	Stainless Steel, 316
CHECK	Stainless Steel, ASTM A276, 316

DIMENSIONS

PART NO. FNPT X FNPT	SIZE	DIMENSIONS (IN.)			WT./100
		A	B	C	
62-501-01	1/4"	2.312	1.125	1.125	38
62-502-01	3/8"	2.312	1.125	1.125	37
62-503-01	1/2"	2.312	1.125	1.125	36
62-504-01	3/4"	2.875	1.375	1.500	75
62-505-01	1"	3.500	1.750	1.937	150

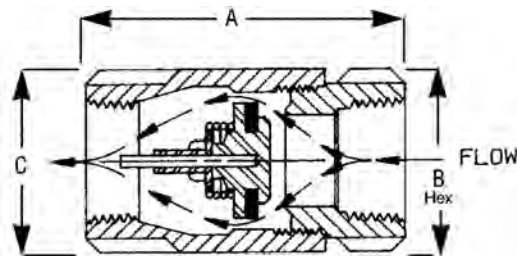

FLOW RATE (C_v)

SIZE	GPM
1/4"	0.47
3/8"	1.57
1/2"	2.20
3/4"	4.78
1"	6

GPM=gallons per minute at 1 psi pressure differential

NOTE: Not recommended for use with reciprocating pumps and similar applications. Low flows may result in undesirable noise and premature valve failure.

PART NO. MATRIX

62	- X	X	X	- XX
TYPE	CHECK	SPRING TYPE	SIZE (IN.)	OPTIONS
62 - STAINLESS STEEL	5 - SOFT SEAT (NPT-F X F)	0 - .5 PSIG CRACKING PRESSURE	1 - 1/4"	01 - STANDARD (VITON SEAT)
	9 - SOFT SEAT REPAIR KIT (VITON ONLY)	2 - .2 PSIG CRACKING PRESSURE	2 - 3/8"	PO1 - BSPP THREAD (ISO 228)**
			3 - 1/2"	TO1 - BSPT THREAD (EN 10226)**
			4 - 3/4"	57 - OXYGEN CLEANED
			5 - 1"	A1 - LESS SPRING
				B1 - NITRILE SEAT
				F1 - EPDM SEAT
				E05 - 5 PSIG OPENING PRESSURE*
				E10 - 10 PSIG OPENING PRESSURE*

*Available in 1/4" through 1" only.

**Minimums apply

(Note: Not all combinations are available. Contact Customer Service for verification.)

GATE, GLOBE & CHECK VALVES

**CV (61-700) SERIES
MINI CHECK VALVE**



**61-700
FEMALE X FEMALE PIPE THREAD
1/4" THROUGH 1"**

The Apollo® Model CV check valve is ideally suited for cold water, and air applications for prevention of reverse flow. The modular check cartridge provides superior leak-tight performance with low pressure loss. It is rated at 230 PSIG with a maximum temperature of 200°F.

FEATURES

- Sizes: 1/4" to 1"
- FNPT x FNPT
- Acetyl Check Valve Body
- Nitrile (Buna-N) Check Seals
- ASTM B16 Brass Housing
- Check Opening Pressure: .5 psi

STANDARD MATERIALS LIST

BODY	Brass, ASTM B16"
CHECK	Acetal/Brass/Silicone/Buna-N
SPRING	Stainless Steel 302

**Not intended for use in potable water applications.*

FLOW RATE (C_v)

SIZE	GPM
1/4"	0.78
3/8"	1.81
1/2"	6.00
3/4"	11.50
1"	17.50

GPM=gallons per minute at 1 psi pressure differential

DIMENSIONS

PART NUMBER	SIZE	DIMENSIONS (IN.)			WT./100
		A	B	C	
61-701-01	1/4"	1.72	0.81	0.92	22
61-702-01	3/8"	1.79	0.93	1.05	29
61-703-01	1/2"	2.02	1.06	1.17	38
61-704-01	3/4"	2.50	1.25	1.40	54
61-705-01	1"	2.95	1.62	1.76	110

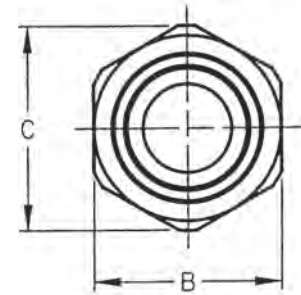
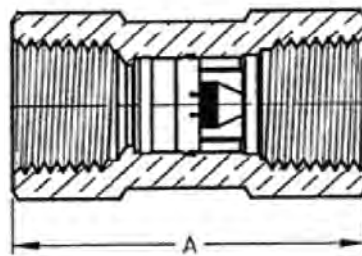



70-100-BC SERIES
BALL VALVE WITH INTEGRAL CHECK



70-100-BC
FEMALE X FEMALE THREADED
1/2" THROUGH 2"

STANDARD MATERIALS LIST

1	BODY	B584-C84400
2	RETAINER	B16 (1/2" - 1") B584-C84400 (1-1/4" - 2")
3	BALL	Brass, B16 (Chrome Plated)
4	CHECK INSERT	Acetal
5	STEM	Brass, B16
6	GLAND NUT	Brass, B16
7	LEVER/GRIP	Steel, Zinc-Plated w/ Vinyl
8	LEVER NUT	Steel, Zinc-Plated
9	O-RING	Buna-N
10	SEATS	RPTFE
11	BODY SEAL	TFE (1-1/4" - 2")
12	STEM PACKING	RPTFE
13	STEM BEARING	RPTFE
14	SEAL	EPDM (1/2")
15	RETAINING RING	Spring Steel (1/2")

*Not intended for use in potable water applications.

The 70-100-BC Series ball valve combines two functions in a single design: positive shut-off and bubble-tight check capabilities. The BC Series is a unidirectional version of the industry-standard Apollo® 70 Series ball valve. An easy flow design and superior check valve make these valves a smart choice for water or air in mechanical systems or OEM applications. Rated at 250 psi CWP and maximum temperature of 200°F.

FEATURES

- Blowout-Proof Stem
- RPTFE Seats and Stuffing Box Ring
- Adjustable Packing Gland
- Chromium-Plated Ball
- Positive Shut-Off and Bubble-Tight Check Capability

DIMENSIONS

PART NUMBER	SIZE	DIMENSIONS (IN.)					WT./100
		A	B	C	D	E	
70-103-BC	1/2"	0.50	1.12	2.25	1.80	3.87	0.63
70-104-BC	3/4"	0.68	4.50	3.00	2.12	4.87	1.33
70-105-BC	1"	0.87	1.68	3.37	2.25	4.87	1.77
70-106-BC	1-1/4"	1.00	2.00	4.00	2.73	5.50	3.29
70-107-BC	1-1/2"	1.25	2.18	4.37	3.09	8.00	4.63
70-108-BC	2"	1.50	2.34	4.68	3.28	8.00	6.01

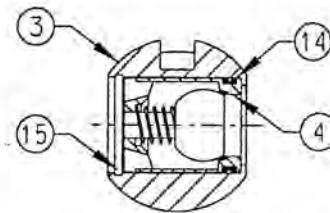
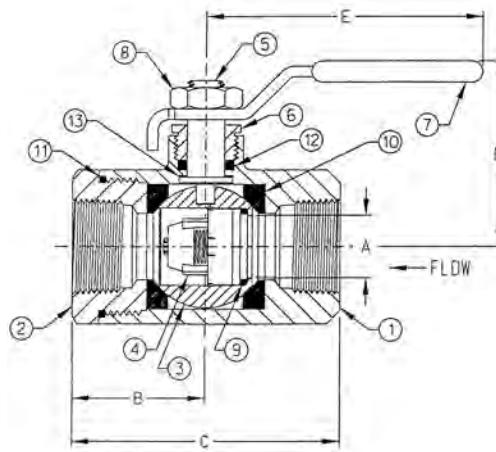

REPAIR KITS
IN-LINE CHECK VALVES

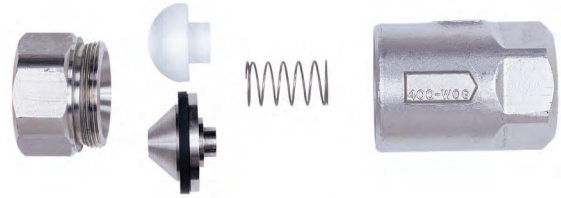
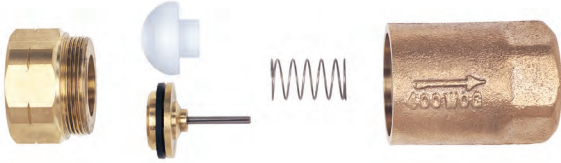

61-100/61LF-100 REPAIR KITS INCLUDE:
SPRING, BALL CONE CHECK & INSTRUCTIONS

SIZE (IN.)	CHECK VALVE PART NO.	LF CHECK VALVE PART NO.	REPAIR KIT PART NO.
1/4"	61-101-01	61LF-101-01	61-001-01
3/8"	61-102-01	61LF-102-01	61-002-01
1/2"	61-103-01	61LF-103-01	61-003-01
3/4"	61-104-01	61LF-104-01	61-004-01
1"	61-105-01	61LF-105-01	61-005-01
1-1/4"	61-106-01	61LF-106-01	61-006-01
1-1/2"	61-107-01	61LF-107-01	61-007-01
2"	61-108-01	61LF-108-01	61-008-01
2-1/2"	61-109-01	61LF-109-01	61-009-01
3"	61-100-01	61LF-100-01	61-010-01

61-600 REPAIR KITS INCLUDE:
SPRING, CHECK ASSEMBLY & INSTRUCTIONS

SIZE (IN.)	CHECK VALVE PART NO.	REPAIR KIT PART NO.
1/2"	61-603-01	61-903-01
3/4"	61-604-01	61-904-01
1"	61-605-01	61-905-01
1-1/4"	61-606-01	61-906-01
1-1/2"	61-607-01	61-907-01
2"	61-608-01	61-908-01

61-200 REPAIR KITS INCLUDE:
SPRING, BALL CONE CHECK & INSTRUCTIONS

SIZE (IN.)	CHECK VALVE PART NO.	REPAIR KIT PART NO.
1/4"	61-201-01	61-001-01
3/8"	61-202-01	61-002-01
1/2"	61-203-01	61-003-01
3/4"	61-204-01	61-004-01
1"	61-205-01	61-005-01
1-1/4"	61-206-01	61-006-01
1-1/2"	61-207-01	61-007-01
2"	61-208-01	61-008-01

62-100 REPAIR KITS INCLUDE:
SPRING, BALL CONE CHECK & INSTRUCTIONS

SIZE (IN.)	CHECK VALVE PART NO.	REPAIR KIT PART NO.
1/4"	62-101-01	62-001-01
3/8"	62-102-01	62-002-01
1/2"	62-103-01	62-003-01
3/4"	62-104-01	62-004-01
1"	62-105-01	62-005-01
1-1/4"	62-106-01	62-006-01
1-1/2"	62-107-01	62-007-01
2"	62-108-01	62-008-01

62-500 REPAIR KITS INCLUDE:
SPRING, CHECK ASSEMBLY & INSTRUCTIONS

SIZE (IN.)	CHECK VALVE PART NO.	REPAIR KIT PART NO.
1/4"	62-501-01	62-901-01
3/8"	62-502-01	62-902-01
1/2"	62-503-01	62-903-01
3/4"	62-504-01	62-904-01
1"	62-505-01	62-905-01

61-500/61LF-500 REPAIR KITS INCLUDE:
SPRING, CHECK ASSEMBLY & INSTRUCTIONS

SIZE (IN.)	CHECK VALVE PART NO.	LF CHECK VALVE PART NO.	REPAIR KIT PART NO.
1/4"	61-501-01	61LF-501-01	61-901-01
3/8"	61-502-01	61LF-502-01	61-902-01
1/2"	61-503-01	61LF-503-01	61-903-01
3/4"	61-504-01	61LF-504-01	61-904-01
1"	61-505-01	61LF-505-01	61-905-01
1-1/4"	61-506-01	-	61-906-01
1-1/2"	61-507-01	-	61-907-01
2"	61-508-01	-	61-908-01

GATE, GLOBE & CHECK VALVES



CV COEFFICIENTS
FOR FLOW ESTIMATION ONLY

FLOW OF LIQUID

$$Q = \sqrt{\frac{\Delta P}{SG}}$$

$$\text{or } \Delta P = \frac{(Q)^2 (SG)}{(Cv)^2}$$

WHERE:

Q = flow rate (gpm)
Cv = device flow coefficient
ΔP = change in fluid pressure across the device (psi)
SG = Specific Gravity of fluid

FLOW OF GAS

$$Q = 1360 Cv \sqrt{\frac{\Delta P (P_2)}{(SG) (T)}}$$

$$\text{or } \Delta P = \frac{5.4 \times 10^{-7} (SG) (T) (Q)^2}{(Cv)^2 (P_2)}$$

WHERE:

Q = flow rate (SCFH)
ΔP = change in fluid pressure across the device (psi)
SG = Specific Gravity (Air - 1.0)
P₂ = outlet pressure - psia (psig + 14.7)
T = (temp. °F + 460)
Cv = valve constant

Note: The Cv (Valve Constant) is the gallons of water per minute that the valve will pass with a 1 PSIG pressure drop across the valve.

NOTE:

Not recommended for use with reciprocating pumps and similar applications which may induce repetitious vibrations. Low flow rates which do not fully open the valve, may result in undesirable noise and premature valve failure. Upstream flow disturbances, which create turbulence, may also result in rapid wear. Therefore, it is recommended that a minimum of 10 diameters of straight pipe be provided between the check valve and any upstream flow disturbances such as pumps, control valves, elbows, etc.

EPDM SEAT

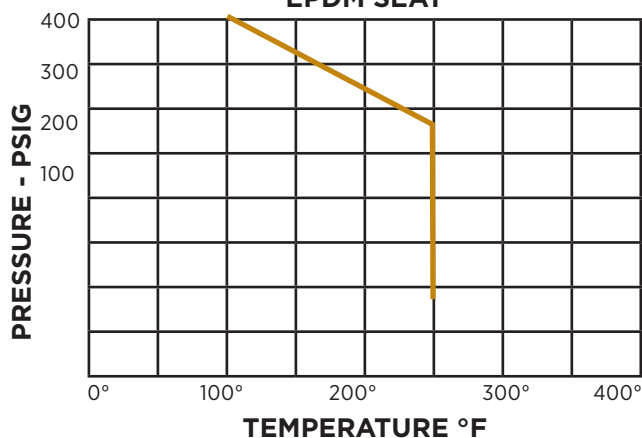

VITON® SEAT

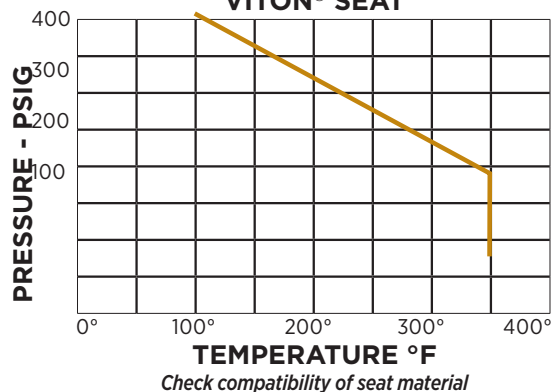

RTFE SEATS

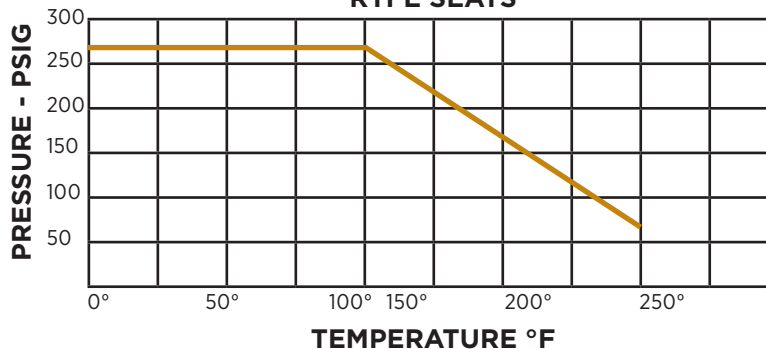

GATE, GLOBE & CHECK VALVES



GLOSSARY

BRONZE VALVE TYPES:

Apollo® offers cast bronze alloy gate, globe, swing check and in-line check valves in a variety of configurations and sizes:

GATE VALVES: Apollo® gate valves are all fully guided solid wedge style available in Type 1A, "Non-Rising Stem and External Stuffing Box" and Type 2, "Rising Stem, Inside Screw, External Stuffing Box" designs.

GLOBE VALVES: Apollo® globe valves are available in Type 1, "Metallic Disc, Integral Seat" and Type 2, "Non-Metallic Disc, Integral Seat", and Type 3, "Metallic Disc, Replaceable/Renewable Seat" designs.

CHECK VALVES: Apollo® swing check valves are available in Type 3, "Metal to Metal Seated", and Type 4, "Non-Metallic Disc, Metal Seat" designs.

IN-LINE CHECK VALVES: Apollo® in-line check valves are available 1/4" - 2".

CAST IRON VALVE TYPES:

Apollo® offers ANSI Class 125 and 250 flanged cast iron gate, globe and swing check valves; ASME B16.10 ANSI Face-to-Face and End-to-End Dimensions of Valves; ASME B16.1

GATE VALVES: Flanged cast iron gate valves are solid wedge design (Type I) with bronze mounted seat rings and are available in both non-rising stem and OS&Y configurations.

GLOBE VALVES: Flanged cast iron globe valves are offered in Type I (in line metal to metal seated) with bronze mounted seat rings. All feature OS&Y stem designs.

SWING CHECK VALVES: Flanged cast iron swing check valves are all Type I (full waterway, metal to metal seated) with bronze mounted seat rings.

WAFFER CHECK VALVES: Resilient seated, dual disc, spring-return design intended for installation between Class 125 or Class 150 flanges.

PRESSURE RATINGS:

SWP: "Steam Working Pressure" is defined as the maximum allowable working pressure for saturated steam service.

CWP: The initials for "Cold Working Pressure" and is the allowable working pressure for the device in the temperature range of -20°F to 100°F (-29°C to 38°C)

The CWP for Apollo® ANSI Class valves is as follows:

Class 125: 200 psig

Class 150: 300 psig

Class 250: 300 psig

Class 300: 1000 psig (600 psig for swing checks)

200 CWP: Commonly applied to bronze solder-end valves and equates to 200 psig.

The SWP for Apollo® ANSI Class Metal-to-Metal seated valves is as follows:

125 SWP: Class 125 is 125 psig.* (353° F)

150 SWP: Class 150 is 150 psig.* (366° F)

300 SWP: Class 300 is 300 psig.* (421° F)

*The maximum saturated steam working pressure (SWP) for soft seated valves is determined by the limits of the non-metallic materials.

TEMPERATURE RATINGS:

Maximum temperature ratings for valves with non-metallic seating (such as is offered in some globe and check valves) are dependant upon the composition of the sealing element. It is the responsibility of the user to specify the service conditions and verify that the valves selected are suitable for their intended use.

END CONNECTIONS:

FLANGED ENDS: All iron valves (with the exception of wafer checks) are supplied with flanged ends which comply with ASME B.16.1 and B16.10. End to end dimensions conform to ANSI B16.10. Class 125, flat faced flanges & Class 250, 0.06 inch raised faced and MSS SP-6 finishes.

THREADED ENDS: Bronze valves supplied with threaded ends comply with ASME B1.20.1.

SOLDER ENDS: Bronze valves supplied with solder joint ends comply with ASME B16.18.

STEM TYPES:

RISING STEM: Rising stem, inside screw is the most common stem design used in bronze gate and globe valves, while the larger cast iron valves use an OS&Y (outside screw and yoke) design. In the fully open, back seated position the stem threads are isolated from the media. The rising stem also give a clearly visible indication as to whether the valve is open or closed. Because the stem and handle rise above the valve during operation, adequate clearance must be provided.



NON-RISING STEM: Applicable only to gate valves. Valves with non-rising stems have a lower profile but the stem threads are exposed to the media leaving them subject to damage from erosion, corruptions or deposits. There is no visual open-closed indication.

BONNET OPTIONS:

THREADED BONNET: This is the most cost effective method for assembling the bonnet of gate and globe valves.

UNION BONNET: Union bonnets are intended to simplify inspection of the interior of the valve.
All Apollo® cast iron gate, globe and swing check valves utilize bolted bonnet construction.

BOLTED BONNET: All Apollo® cast iron gate, globe and swing check valves utilize bolted bonnet construction.

MATERIALS OF CONSTRUCTION - BRONZE VALVES:

STANDARD VALVES: All materials of construction comply with the requirements of MSS SP-80. Class 125, Class 150 and 200 CWP bodies and bonnets or covers are produced from ASTM B62 cast bronze containing a nominal 85% copper. Class 300 bodies and bonnets or covers are produced from ASTM B61 cast bronze containing a nominal 88% copper. Stems are produced from ASTM B371 silicon bronze.

LEAD FREE VALVES: Bodies and bonnets or covers are produced from ASTM B584-C89836 cast bronze containing a nominal 89% copper and no more than 0.25% lead. Stems are produced from ASTM B371 silicon bronze.

MATERIALS OF CONSTRUCTION - CAST IRON VALVES:

All materials of construction comply with the requirements of the governing MSS specification. Cast iron body and bonnet material is ASTM A126 Class B. All bolting is equal to or better than ASTM A307 B.

BRONZE & CAST IRON STEM PACKING:

All Apollo® gate and globe valves are factory equipped with die-formed graphite stem packing which ensures an effective seal under a wide range of service conditions.

BRONZE MARKING:

All Apollo® bronze gate, globe and swing check valves are marked in compliance with MSS SP-80, MSS SP-139 and MSS SP-25. Swing check valves include a cast flow direction arrow. lead free valves feature a cast "LF" symbol where space permits.

CAST IRON MARKING:

All Apollo® gate, globe and check valves are marked in compliance with MSS SP-25 and the governing MSS product standard.

BRONZE TESTING:

All Apollo® bronze gate, globe and swing check valves are tested in compliance with MSS SP-80 and MSS SP-139. 61 and 62 Series in-line check valves are tested in accordance with Apollo® specifications

CAST IRON TESTING:

Each Apollo® iron gate, globe and check valve is tested in compliance with MSS SP-70, SP-71 or SP-85 as applicable.



"Apollo"[®]

BRONZE WYE STRAINERS

59, 59LF	K-2
59/59LF-P	K-3
59/59LF-PR	K-3
59/59LF-300	K-4

BRONZE MINI-STRAINER

59V	K-4
-----	-----

STAINLESS STEEL WYE STRAINER

612	K-4
-----	-----

CAST IRON WYE STRAINER

YCT	K-5
YCF	K-6

CARBON STEEL WYE STRAINER

612	K-5
-----	-----

STRAINERS

**YB (59) SERIES
BRONZE WYE STRAINER**



59-000 Series

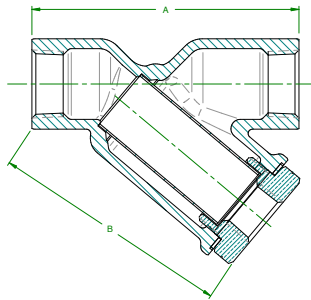

Heavy pattern design with large area screens ensures excellent protection against foreign particles in your fluid system. Corrosion-resistant bronze body and stainless steel screens provide years of service.

FEATURES

- Blow-Off Ball Valve Option (3/4" - 2")
- Replaceable Self-Aligning Screen
- Large Net Flow Area for Longer Maintenance Intervals
- 59-400 Series is Female x Male NPT (3/4" & 1" Only)
- Several Screen and Cap Options
- **Made in USA, ARRA Compliant**

PERFORMANCE RATING

- Working Pressure:
CWP: 400 psi
SWP: 125 psi
- Maximum Temperature: 350° F

APPROVALS

- NSF/ANSI 372 Lead Free (59LF)
- CRN-OE 8959.5

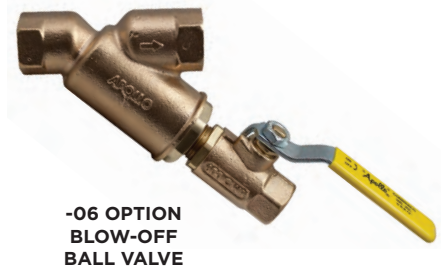

STANDARD SCREEN

SIZE (IN.)	SCREEN
1/8" - 1/2"	50 Mesh
3/4" - 3"	20 Mesh
4"	.125 Perforation

OPTIONS

SUFFIX	OPTION
-01	Plain Cap
-02	Blowout Tap
-P2	Blowout with Plug
-06	Ball Valve
-E1	20 Mesh
-B1	60 Mesh
-C1	80 Mesh
-H1	100 Mesh

DIMENSIONS

PART NUMBER	LF PART NUMBER	MODEL NUMBER	SIZE	DIMENSIONS		CAP TAPPING SUFFIX -02	WT./EA. LB.	NET SCREEN AREA (IN.) ²
				A (IN.)	B (IN.)			
59-000-01	59LF-000-01	YB14	1/8 NPT	2.00	1.25	1/8 NPT	.4	2.3
59-001-01	59LF-001-01	YB14	1/4 NPT	2.00	1.25	1/8 NPT	.4	2.3
59-002-01	59LF-002-01	YB38	3/8 NPT	2.69	2.00	1/4 NPT	.8	3.2
59-003-01	59LF-003-01	YB12	1/2 NPT	2.69	2.00	1/4 NPT	.8	3.2
59-004-01	59LF-004-01	YB34	3/4 NPT	4.25	3.25	1/2 NPT	1.9	6.7
59-005-01	59LF-005-01	YB1	1 NPT	4.75	4.00	3/4 NPT	2.8	10.8
59-006-01	59LF-006-01	YB114	1-1/4 NPT	5.13	4.25	3/4 NPT	3.6	13.5
59-007-01	59LF-007-01	YB112	1-1/2 NPT	5.75	5.00	1 NPT	5.4	19.0
59-008-01	59LF-008-01	YB2	2 NPT	6.66	6.00	1-1/4 NPT	7.5	27.6
59-009-01	59LF-009-01	YB212	2-1/2 NPT	8.24	6.87	1-1/4 NPT	11.3	41.0
59-010-01	59LF-010-01	YB3	3 NPT	9	6.87	1-1/2 NPT	15.8	56.0
59-011-01	59LF-011-01	YB4	4 NPT	11.92	10.12	1-1/2 NPT	30.7	98
59-404-01	59LF-404-01	YBM34	3/4 F x MNPT	NA	3.25	1/2 NPT	2.0	6.7
59-405-01	59LF-405-01	YBM1	1 F x MNPT	NA	4.00	3/4 NPT	3.0	10.8

YB (59) SERIES
BRONZE WYE STRAINER - PUSH



DEMOUNT TOOLS

SIZE	APOLLO PART NUMBER	EPC PART NUMBER
1/2"	D514500	10165630
3/4"	D514800	10165625
1"	D515100	10165627

The ApolloPush (59LF Series) Strainers with quick push connections are designed to protect potable water systems from unwanted foreign particles with minimum pressure loss. The valves are built for long reliable service with proven ASTM grade materials including a lead free bronze body and a large area stainless steel screen.

FEATURES

- Quick ApolloPush Incorporates Proven TECTITE™ Technology
- Direct Connectors are Permanently Installed
- Self-Aligning Screen Design
- Pushed Connections are Removable Using Optional Demounting Tool
- Standard Valve:
 - (01) Plain Cap 50 Mesh (1/2")
 - (01) Plain Cap 20 Mesh (3/4", 1")
- Blow-Off Ball Valve Option
- **Made in USA, ARRA Compliant**

APPROVALS

- ASSE 1061 - Push Fitting Performance Requirements
- IAPMO IGC 188 (UPC) Compliant for CU/CPVC/PEX
- CRN OE8959.5
- NSF/ANSI 372 Lead Free (59LF)

PERFORMANCE RATING

- Maximum Pressure: 200 psi
- Maximum Temperature: 250° F

DIMENSIONS

LF PART NUMBER	PART NUMBER	EPC LF PART NUMBER	EPC MODEL NUMBER	SIZE	LENGTH	CV	WT. (LB.)
59LF-003-01P	59-003-01P	10177538	230	1/2"	4.9"	5	.75
59LF-004-01P	59-004-01P	10177541	230	3/4"	6.2"	15	1.7
59LF-005-01P	59-005-01P	10177543	230	1"	7.5"	28	2.7

For liquids the flow coefficient - Cv - expresses the flow capacity in gallons per minute (GPM) of 60°F water with a pressure drop of 1 psi (lb/in²).

YB (59) SERIES
BRONZE WYE STRAINER - PRESS



OPTIONS

SUFFIX	OPTION
-01	50 Mesh (Std 1/2")
-01	20 Mesh (Std 3/4" - 2")
-02	Tapped Cap
-P2	Tapped Cap with Plug
-06	Tapped Cap with Ball Valve
-E1	20 Mesh (for 1/2")
-B1	60 Mesh
-C1	80 Mesh
-H1	100 Mesh
-59PR	ApolloPress

The ApolloPress YB-PRLF (59LF Series) Strainers with quick press connections are designed to protect potable piping systems from unwanted foreign particles with minimum pressure loss. The valves are built for long reliable service with proven ASTM grade materials including a lead free bronze body and stainless steel strainer.

FEATURES

- Lead Free Bronze Construction
- Fast, Reliable, Economical Press Installation
- Ridgid® XL Press Tool Compatible
- Leak Before Press® Technology
- Self-Aligning SS Screen Design
- Blow-Off Ball Valve Option
- **Made in USA, ARRA Compliant**

APPROVALS

- NSF/ANSI 372 Lead Free (59LF)
- CRN OE8959.5C

PERFORMANCE RATING

- Maximum Pressure: 250 psi
- Maximum Temperature: 250°F

DIMENSIONS

LF PART NUMBER	PART NUMBER	SIZE (IN.)	LENGTH	CV	WT. (LB.)
59LF-003-01PR	59-003-01PR	1/2"	4.75"	5	1.0
59LF-004-01PR	59-004-01PR	3/4"	6.1"	15	2.0
59LF-005-01PR	59-005-01PR	1"	7.25"	28	3.0
59LF-006-01PR	59-006-01PR	1-1/4"	7.62"	55	3.8
59LF-007-01PR	59-007-01PR	1-1/2"	8.25"	70	5.7
59LF-008-01PR	59-008-01PR	2"	10.39"	99	7.7

For liquids the flow coefficient - Cv - expresses the flow capacity in gallons per minute (GPM) of 60°F water with a pressure drop of 1 psi (lb/in²).

**YBS (59-300) SERIES
BRONZE WYE STRAINER**

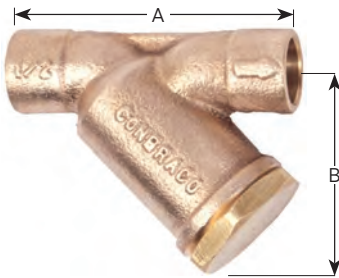

Heavy pattern design with large area screens ensures excellent protection against foreign particles in your fluid system. Corrosion-resistant bronze body and stainless steel screens provide years of service.

FEATURES

- Sizes: 1/2" to 3" Copper Tube Size
- Optional Tapped Caps Available
- 59LF features EZ-Solder™ Bronze
- **Made in USA**

PERFORMANCE RATING

- Working Pressure:
CWP: 400 psi
SWP: 125 psi
- Maximum Temperature: 350° F

APPROVALS

- NSF/ANSI 372 Lead Free (59LF)

DIMENSIONS

SERIES NUMBER	LF SERIES NUMBER	SIZE (IN.)	DIMENSIONS (IN.)		TAPPED CAP SUFFIX -02	WT.	NET SCREEN AREA (IN. ²)
			A	B			
59-303-01	59LF-303-01	1/2	2.75	2.0	1/4 NPT	.50	3.19
59-304-01	59LF-304-01	3/4	4.00	3.0	1/2 NPT	1.21	6.7
59-305-01	59LF-305-01	1	4.75	3.5	3/4 NPT	1.89	10.8
59-306-01	59LF-306-01	1-1/4	5.25	4.0	3/4 NPT	2.80	13.5
59-307-01	59LF-307-01	1-1/2	6.00	4.4	1 NPT	4.26	19.0
59-308-01	59LF-308-01	2	7.25	5.1	1-1/4 NPT	6.27	27.6
59-309-01	59LF-309-01	2-1/2	9.50	5.6	1-1/2 NPT	11.00	41.0
59-310-01	59LF-310-01	3	10.50	6.7	1-1/2 NPT	15.0	56.0

STANDARD SCREENS

SIZE (IN.)	STANDARD SCREEN
1/2	50 Mesh
3/4 to 3	20 Mesh

OPTIONS

SUFFIX	OPTION
-01	Solid cap (standard)
-02	Blowout Tap
-P2	Blowout with pipe plug

**YBV (59V) SERIES
"MINI" STRAINER**

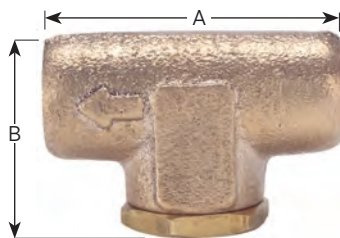

The body of the 59-V is corrosion-resistant solid cast bronze, ASTM B-584. The removable clean-out cap is solid brass, ASTM B-16. Standard screens are made of 304 stainless steel. NOT INTENDED FOR POTABLE WATER

FEATURES

- C_v Factor 1.42 GPM

PERFORMANCE RATING

- Working Pressure:
CWP: 400 psi
SWP: 125 psi
- Maximum Temperature: 350° F

DIMENSIONS

SERIES NUMBER	SIZE (IN.)	DIMENSIONS (IN.)		WT./100	SCREEN MESH
		A	B		
59V-001-01	1/4 NPT	2.00	1.31	29.7	50
59V-001-H1	1/4 NPT	2.00	1.31	29.7	100

**YSS (612) SERIES
STAINLESS STEEL WYE STRAINER**

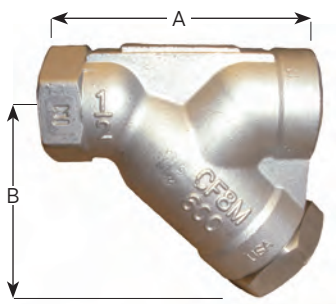

Sturdy and compact with corrosion-resistant stainless steel bodies and stainless steel screens.

FEATURES

- Body is ASTM 316 Stainless Steel Grade CF8M
- 20 Mesh Screen
- Gasket 304 SS/Graphite
- Screen cover is NPT tapped for Customer Supplied Plug or Blow-Off Valve
- **Made in USA**

PERFORMANCE RATING

- Working Pressure:
CWP: 1480 psi
SWP: 600 psi
- Maximum Temperature: 488° F

DIMENSIONS

SERIES NUMBER	SIZE (IN.)	DIMENSIONS (IN.)		BLOW-OFF NPT	WT. (LB.)	NET SCREEN AREA (IN. ²)
		A	B			
612-033-A1	1/2	3.38	2.75	3/8	2	5.4
612-034-A1	3/4	4.44	3.63	3/8	3.75	8.7
612-035-A1	1	4.88	3.75	1/2	4	12.7

YCT SERIES

CAST IRON WYE STRAINER - APOLLO INTERNATIONAL™

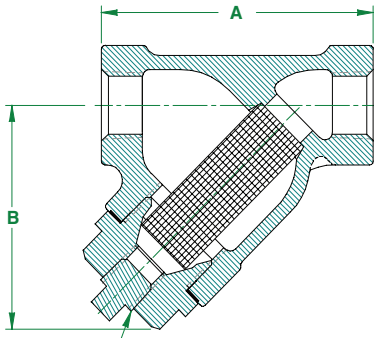

Install these durable strainers upstream in almost any application to protect valves, regulators, solenoids and meters from rust, dirt and pipe scale.

FEATURES

- 20 Mesh Screens Standard to 2"; .045 perf. 2-1/2" to 3", Others Available
- Graphite Gasketed Cover for Easy Screen Cleaning
- Standard Tapped Cap with Plug
- Sizes: 1/4" to 3"
- Connections are NPT to ASME/ANSI B1.20.1
- FDA Approved Epoxy Coating

PERFORMANCE RATING

- Working Pressure: CWP: 500 psi SWP: 250 psi
- Maximum Temperature: 406° F

APPROVALS

- NSF/ANSI 372 Lead Free

DIMENSIONS

SERIES NUMBER	SIZE (IN.)	DIMENSIONS (IN.)		BLOW-OFF NPT	WT. (LB.)	NET SCREEN AREA (IN. ²)
		A	B			
YCT01M20	1/4	3.19 ± .04	2.17	1/4"	.44	2.8
YCT02M20	3/8	3.19 ± .04	2.24	1/4"	.57	2.8
YCT03M20	1/2	3.19 ± .04	2.76	3/8"	.75	2.8
YCT04M20	3/4	3.74 ± .06	2.83	3/8"	1.10	4.7
YCT05M20	1	4.02 ± .07	3.07	1/2"	1.90	7.0
YCT06M20	1-1/4	5.00 ± .07	3.62	1/2"	3.20	12.1
YCT07M20	1-1/2	5.75 ± .08	4.61	1/2"	4.59	16.4
YCT08M20	2	6.97 ± .08	4.69	1/2"	7.39	23.1
YCT09P045	2-1/2	9.21 ± .10	5.35	3/4"	10.56	55.0
YCT00P045	3	10.00 ± .10	5.91	3/4"	13.29	78.4

YCS & YCSW (612) SERIES

CARBON STEEL WYE STRAINER - APOLLO INTERNATIONAL™

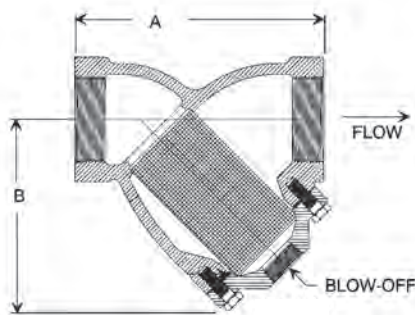

Large volume area screen, reliable construction.

FEATURES

- Body is ASTM A216 Carbon Steel Grade WCB
- 20 Mesh Screen
- Copper Gasket 1/2" to 1-1/2", 304 SS/Graphite on 2"
- Screen Cover is NPT Tapped for Customer Supplied Plug or Blow-Off Valve

PERFORMANCE RATING

- Working Pressure: CWP: 1440 psi SWP: 600 psi
- Maximum Temperature: 488° F

DIMENSIONS

SERIES NUMBER		SIZE (IN.)	DIMENSIONS (IN.)		BLOW-OFF NPT	WT. (LB.)	NET SCREEN AREA (IN. ²)
THREADED NPT	SOCKET WELD		A	B			
612023A1	612123A1	1/2	3.38	2.75	3/8"	2	5.4
612024A1	612124A1	3/4	4.44	3.63	3/8"	3.75	8.7
612025A1	612125A1	1	4.88	3.75	1/2"	4	12.7
612027A1	612127A1	1-1/2	6.38	5.13	3/4"	8.75	25.3
612028A1	612128A1	2	7.50	6.00	1	12	39.2

YCF SERIES
CLASS 125 CAST IRON WYE STRAINER



LEAD FREE

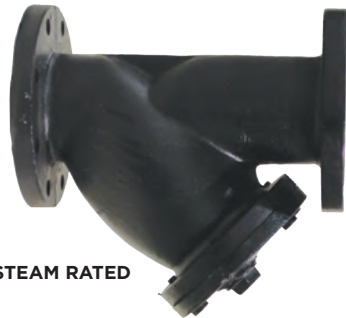

STEAM RATED

The **Apollo International™** YCF Strainers are designed to protect piping systems and process equipment from unwanted foreign particles with minimum pressure loss.

FEATURES

- Iron Strainer with Flat Face Flanges Conforms to ASME/ANSI 16.1 Class 125
- One Piece Cast Body Meets ASME Standard
- Epoxy Coating Models conform to FDA CFR21, Section 175.300 and NSF/ANSI 372 Lead Free
- Equipped with Bolted Cover Employing Flat Gasket Seal
- Upper and Lower Machined Seats for Self-Aligning Screen Design
- 304 SS Perforated Screens are Standard (P045 STD 2"-3", P125 STD 4"-12")
- Tapped Blow Off Connection with Plug
- 100% Factory Pressure Tested

PERFORMANCE RATING (LEAD FREE)

- Working Pressure: CWP: 200 psi @ 150° F
- ***not for steam service.**

PERFORMANCE RATING (STEAM RATED)

- Working Pressure: CWP 200 PSIG SWP 125 PSIG @ 352°F

STANDARD MATERIALS LIST

BODY	Cast Iron, ASTM A126-B
CAP/COVER	Cast Iron, ASTM A126-B
PLUG	Carbon Steel, ASTM A307
BOLT/STUD/NUT	Carbon Steel, ASTM A307
SCREEN	304 Stainless Steel
GASKET	Graphite
COATING (LEAD FREE ONLY)	Epoxy, FDA Approved

DIMENSIONS

PART NUMBER STEAM RATED	PART NUMBER LEAD FREE	SIZE/DN		A		B		C		D		E		F		DRAIN PLUG		WEIGHT	
		IN	MM	IN	MM	IN	MM	IN	MM	IN	MM	IN	MM	IN	MM	IN	MM	LB.	KG.
YCF02P045	YCF02P045E	2"	50	8.86	255	0.63	16	5.98	152	4.75	121	0.75	19	6.30	160	1/2"	4	23	11
YCF25P045	YCF25P045E	2-1/2"	65	10.75	273	0.69	18	7.01	178	5.50	140	0.75	19	7.64	194	1"	4	34	15
YCF03P045	YCF03P045E	3"	80	11.50	292	0.75	19	7.48	190	6.00	153	0.75	19	8.86	225	1"	4	47	21
YCF04P125	YCF04P125E	4"	100	13.86	352	0.94	24	8.98	228	7.50	191	0.75	19	10.63	270	1-1/4"	8	72	33
YCF05P125	YCF05P125E	5"	125	16.38	416	0.94	24	10.00	254	8.50	216	0.88	22	12.60	320	1-1/4"	8	111	50
YCF06P125	YCF06P125E	6"	150	18.50	470	1.00	25	10.98	279	9.50	242	0.88	22	14.69	373	1-1/2"	8	150	68
YCF08P125	YCF08P125E	8"	200	21.38	543	1.12	29	13.46	342	11.75	299	0.88	22	17.72	450	1-1/2"	8	235	107
YCF10P125	YCF10P125E	10"	250	25.98	660	1.18	30	15.98	406	14.25	362	1.00	25	20.67	525	2"	12	369	168
YCF12P125	YCF12P125E	12"	300	30.00	762	1.25	32	19.02	483	17.00	432	1.00	25	23.94	608	2"	12	552	250

PART NUMBER MATRIX

YCF	XXX	XXX[X]	X
	CONNECTION SIZE	SCREEN TYPE	OPTION
YCF (FLAT FACE)	F02 - FLANGED 2"	M20 - 20 MESH	E - EPOXY COATING, FDA APPROVED
	F25 - FLANGED 2.5"	M40 - 40 MESH	LEAD FREE ONLY, NOT FOR STEAM
	F03 - FLANGED 3"	M80 - 80 MESH	
	F04 - FLANGED 4"	M100 - 100 MESH	
	F05 - FLANGED 5"	P045 - .045" PERF	
	F06 - FLANGED 6"	P125 - .125" PERF	
	F08 - FLANGED 8"		
	F10 - FLANGED 10"		
	F12 - FLANGED 12"		

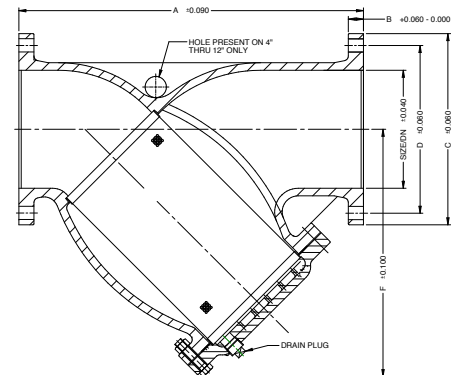

*All mesh screens include liner:
 .045" Perf on 3" and smaller
 .125" Perf on 4" and larger
 **All screens not available for all sizes.
 ***Limited screen options available for non-lead free steam rated version.

ENGINEERING DATA
SCREEN OPENINGS

PURPOSE

If the strainer is being used for protection rather than direct filtration, Apollo's standard screens will suffice in most applications.

SERVICE

With services that require extremely sturdy screens, such as high pressure/ temperature applications or services with high viscosities, Apollo® recommends that perforated screens without mesh liners be used. If mesh is required to obtain a certain level of filtration, then Apollo® recommends a trapped perf./ mesh/perf. combination.

FILTRATION LEVEL

When choosing a perf. or a mesh/perf. combination attention should be given to ensure overstraining does not occur. As a general rule the specified level of filtration should be no smaller than half the size of the particle to be removed. If too fine a filtration is specified the pressure drop through the strainer will increase very rapidly, possibly causing damage to the basket.

SCREEN TYPES & DIMENSIONS

1/8" Dia. - 40% O.A. (P125)	1/16" Dia. - 37% O.A. (P045)	20 Mesh - 49% O.A. 0.035" Openings	40 Mesh - 41% O.A. 0.016" Openings	80 Mesh - 36% O.A. 0.008" Openings	100 Mesh - 30% O.A. 0.006" Openings

STANDARD SCREENS

SIZE RANGE	OPENING
2" - 3"	0.045 in.
50mm - 80mm	1.2mm
4" and larger	0.125 in.
100mm and larger	3.2mm

*All screens not available for all sizes
All mesh screens include liner:
.045 Perf 3" and smaller
.125 Perf 4" and larger*

ENGINEERING DATA
EFFECTIVE SCREEN AREA

PIPE SIZE (IN.)	STD. OPENING (IN.)	NOMINAL AREA OF PIPE FITTING (SQ. IN.)	GROSS SCREEN AREA (SQ. IN.)	FREE AREA (SQ. IN.)	RATIO FREE AREA TO PIPE AREA
2	0.045	3.14	30.07	10.82	3.45
2-1/2	0.045	4.91	44.33	15.96	3.25
3	0.045	7.07	56.45	20.32	2.88
4	0.125	12.57	98.91	39.56	3.15
5	0.125	19.63	147.11	58.85	3.00
6	0.125	28.27	179.19	71.68	2.54
8	0.125	50.27	334.38	133.75	2.66
10	0.125	78.54	505.21	202.08	2.57
12	0.125	113.10	665.77	266.31	2.35

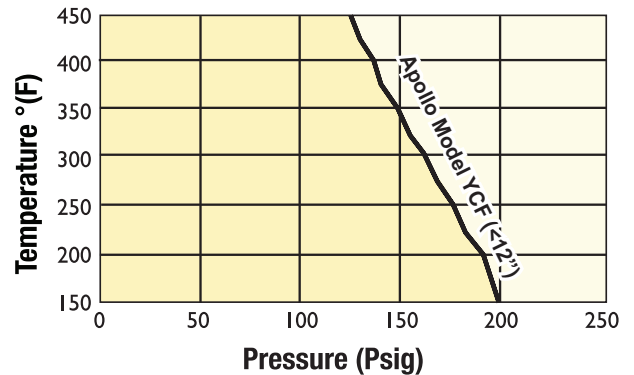

ENGINEERING DATA

PRESSURE DROP (LIQUIDS)

The following optional features are available for most Apollo® Y-Strainers. Please consult factory if required feature not shown.

FEATURE	DESCRIPTION OF AVAILABILITY
Screen Openings	Range 150 micron to 1/4" perf.
Screen Materials	Stainless Steel (304)
Screen Construction	Perforated Plate/Mesh Wir.
Gaskets	Graphite
Standard coating	FDA Epoxy Coating

*Strainer size may effect the ability to apply certain coatings and linings.

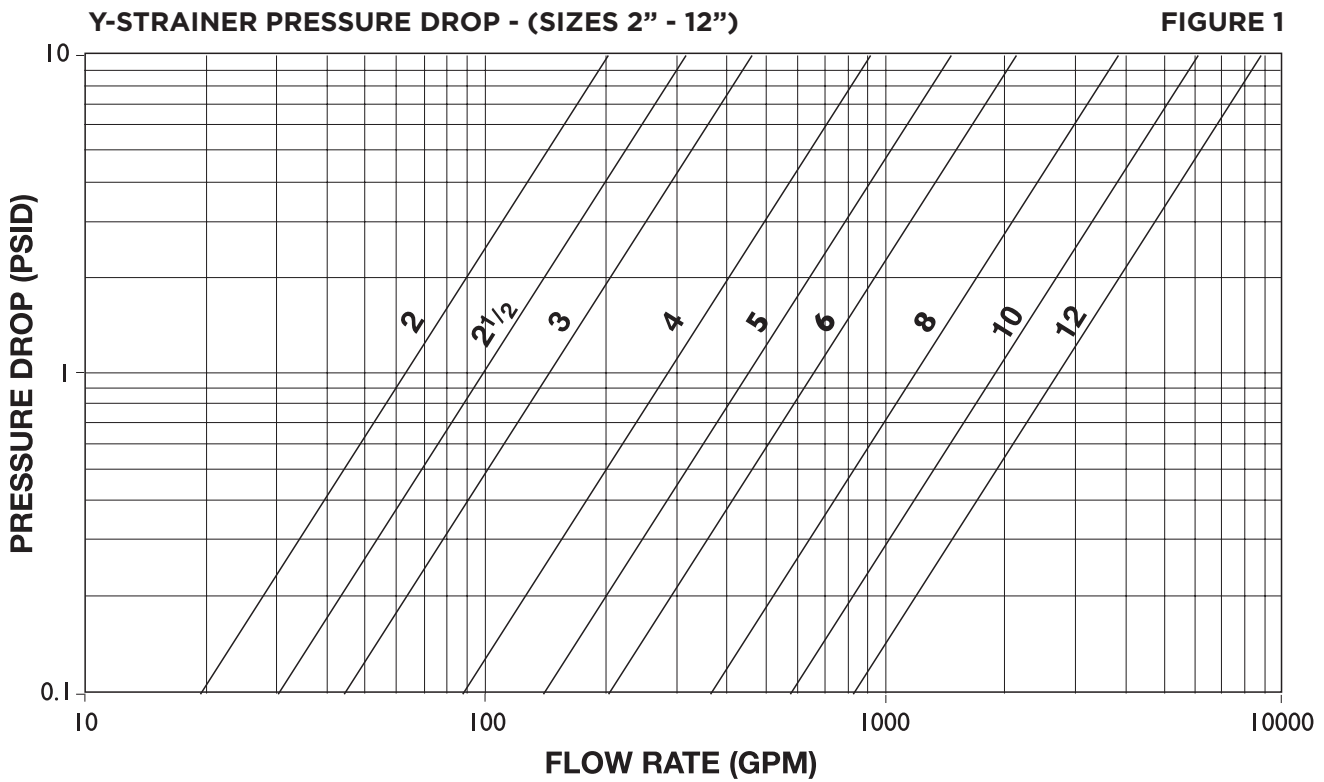

*Pressure drop curves are based on water flow with standard screens.
See technical data for correction factors to be used with other fluids and/or screen openings.*

ENGINEERING DATA
SCREEN CORRECTION FACTOR CHART

CHART 1

SIZE RANGE	PERFORATED PLATE % SCREEN MATERIAL OPEN AREA					MESH LINED STANDARD SCREENS % SCREEN MATERIAL OPEN AREA		
	60%	50%	40%	30%	20%	50%	40%	30%
	2" - 12"	0.65	0.8	1	1.4	2.15	1.05	1.05

* Multiply values obtained from figure 1 thru 4 by the appropriate values shown below

See perforated plate open areas chart
Standard screens for sizes 2" and larger is approximately a 40% open area screen media.
All mesh screens include liner:
.045 Perf 3" and smaller
.125 Perf 4" and larger

EXAMPLE:

Strainer Size: 2"
Filtration: 100 mesh lined
Flow Rate: 65 GPM
Service: Water

Using Figure 1 the pressure drop is determined to be 1.0 psid with Apollo's standard screen.
See perforated plate open areas chart to find that the % open area of 100 mesh is 30%.
Using Chart 1 we read the correction factor to be 1.2 for 100 mesh lined .045" perf
Total pressure drop equals 1.0 x 1.2 = 1.2 psid clean.

VISCOSITY AND DENSITY CORRECTION FACTOR CHART

CHART 2

SIZE RANGE	COMPONENT FACTOR (CF)
2" - 12"	0.35

CHART 3

VISCOSITY CP	BODY LOSS FACTOR (BF)	SCREEN LOSS FACTOR			
		PERF ALONE (PF)	20 MESH LINED (MF)	40 MESH LINED (MF)	60 TO 100 MESH LINED (MF)
10	1	1.15	1.3	1.4	1.5
25	1.2	1.25	2	2.2	2.5
100	1.6	1.4	3	4	6.5
200	2.2	1.5	4.5	7	11.5
500	4.4	1.6	10	15	25
1000	8	1.7	15	30	50
2000	15.2	1.9	30	60	100

HOW TO USE

- Using Figure 1, determine the pressure drop (P1) through the strainer with water flow and standard screens.
- If non-standard screens (i.e. 40 mesh, etc.) are being used apply factors in
- Use Chart 1 to determine corrected pressure drop (P2).
- Multiply P1 or P2 (is used) by the specific gravity of the fluid actually flowing through the strainer to get P3.
- Using Chart 2 multiply P3 by the appropriate Component Factor (CF) to get P4.
- Let P5 = P3 - P4.
- Multiply P4 by the appropriate Body Loss Factor (BF) in Chart 3 to get P6.
- Multiply P5 by the appropriate Screen Loss factor (PF or MF) in Chart 3 to get P7.
- Total pressure drop P8 = P6 + P7.

EXAMPLE:

Strainer Size: 2"
Filtration: 100 mesh lined
Specific Gravity: 1
Viscosity: 25 cP

As shown in the above example, the corrected pressure drop (P2) = 1.2 psid
Since S.G. = 1, P3 = P2 = 1.2 psid
Using Chart 2, P4 = 0.35 x P3 = 0.42 psid
P5 = 1.2 - 0.4 = 0.8 psid
Using Chart 3, P6 = 0.4 x 1.2 = 0.48 psid
Again using Chart 3 P7 = 0.8 x 2.5 = 2.0 psid
Total pressure drop P8 = 0.48 + 2.0 = 2.48 psid

ENGINEERING DATA
 PRESSURE DROP (SATURATED STEAM)
 SIZES 2" - 12"

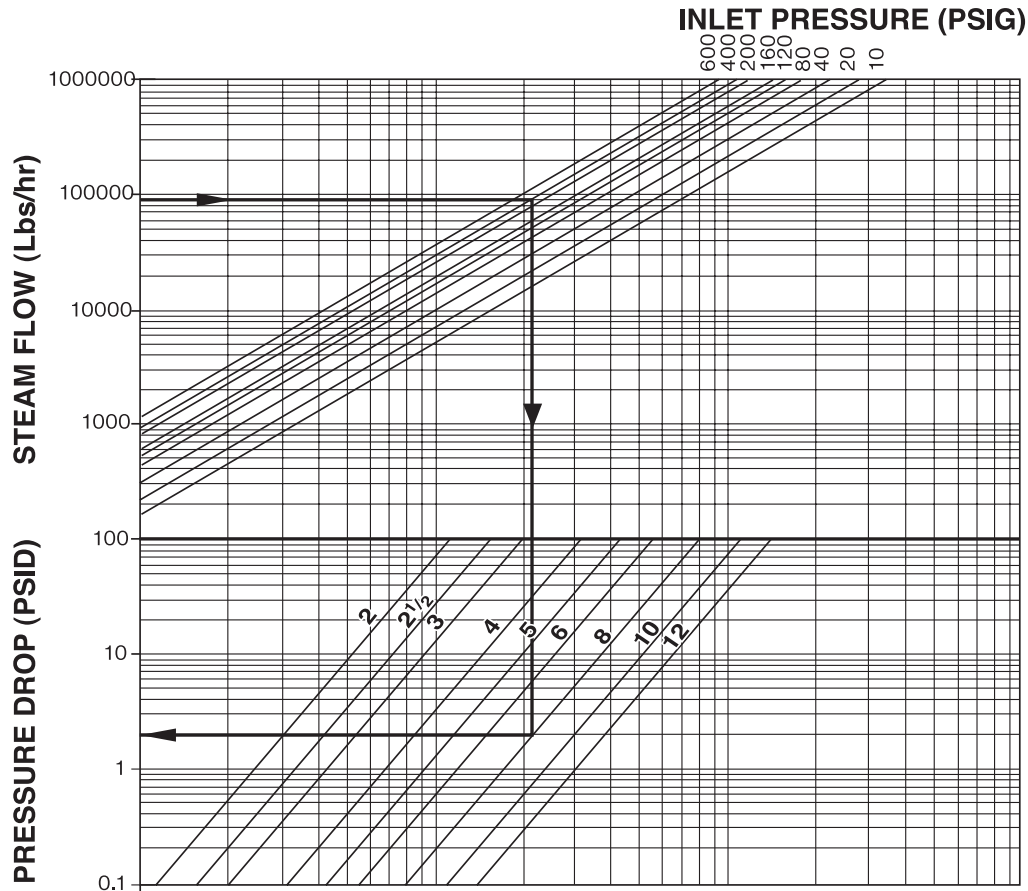

Pressure drop curve is based on saturated steam flow with standard screens. See page 5 for correction factors to be used with other screen openings.

Chart can be used for air and gas by using the following formula:

$$Q_s = 0.138 Q_g \sqrt{(460+t) \text{ s.g.}} \left\{ \frac{DP}{P_2} < 1.0 \right\}$$

FOR NON-CRITICAL FLOW

STRAINERS

WHERE

- Qs - Equivalent Steam Flow, Lbs./Hr.
- Qg - Air or gas flow, SCFM.
- t - Temperature, °F.
- s.g. - Specific gravity (s.g. - 1 for air.)
- DP - Pressure Drop, psid
- P2 - Outlet Pressure

EXAMPLE:
 Service: Saturated Steam
 Pressure: 400 psig
 Steam Flow: 90,000 Lbs./Hr.
 Size: 8"

Locate steam flow.
 Follow horizontal line to required pressure.
 Follow vertical line downwards to required stainer size.
 Follow horizontal line to read pressure drop
 Pressure drop equals 2.0 psid.

CHECKLIST AND SUGGESTED SPECIFICATIONS

STRAINER CHECKLIST

When selecting a strainer, please take the factors listed below into account. This will assist us when recommending a strainer to suit your specific requirements.

Fluid to be Strained: _____
 Flow Rate: _____
 Density of Fluid: _____
 Viscosity of Fluid: _____
 Fluid Working Pressure: _____
 Maximum Pressure: _____
 Fluid Working Temp.: _____
 Maximum Temp.: _____
 Preferred Strainer Material: _____
 Present Pipeline Size & Material: _____
 Nature of Solids to be Strained Out: _____
 Size of Solids to be Strained Out: _____
 Size of Mesh or Perf. Req.: _____
 Clearance Limitation: Above: _____ Below: _____
 Left Side Facing Inlet: _____
 Right Side Facing Inlet: _____
 Max Pressure Drop with Clean Screen: _____
 Expected Cleaning Frequency: _____
 Any Other Relevant Information: _____

SUGGESTED SPECIFICATIONS

The strainer shall be a Y-Type and have _____ (size) inlet/outlet connections. The end connections shall be flanged and the body shall be complete with a bolted cover assembly. The strainer shall be suitable for _____ PSIG operating pressure at _____°F operating temperature. The body shall be constructed of _____ (body material) while the screen shall be constructed of _____ (screen material). A mesh lining of _____ (size of mesh) is required, allowing a maximum pressure drop of _____ psig. The strainer shall be equipped with a _____ (gasket material) gasket and the strainer screen shall be able to withstand _____ psig differential pressure without any deformation.

Strainers shall be Apollo® Model # _____ or approved equivalent.

Name _____
 Company _____
 Address _____
 City _____
 State _____ Zip Code _____
 Telephone (_____) _____
 Fax (_____) _____

INSTALLATION & MAINTENANCE INSTRUCTIONS

STRAINER INSTALLATION INSTRUCTIONS

1. Ensure all machined surfaces are free of defects and that the inside of the strainer is free of foreign objects.
2. For horizontal pipelines, the strainer should be installed so that the drain connection is pointed downwards.
3. For flanged end strainers, the flange bolting should be tightened gradually in a back and forth clockwise motion.
4. Once installed, increase line pressure gradually and check for leakage around joints.
5. If the strainer is supplied with a start-up screen, monitor pressure drop carefully.

NOTE: Flat face mating flanges and full face gaskets must be used with YCF series strainers to avoid damage to the cast iron body.

IMPORTANT

Ultimate responsibility for strainer and material selection rests with the customer, as only the customer knows the particular use to which the strainer will be put and the exact operating parameters to which it will be subjected.

STRAINER REMOVAL INSTRUCTIONS

1. Drain piping.
2. Vent line to relieve pressure.
3. Secure necessary lifting equipment to strainer assembly.
4. Loosen flange bolts (Pipe flanges only).
5. Remove inlet/outlet flange bolts and carefully remove strainer.

CAUTION SHOULD BE TAKEN DUE TO POSSIBLE EMISSION OF PROCESS MATERIAL FROM PIPING. ALWAYS ENSURE NO LINE PRESSURE EXISTS WHEN OPENING COVER.

MAINTENANCE INSTRUCTIONS

For maximum efficiency, determine the length of time it takes for the pressure drop to double that in the clean condition. Once the pressure drop reaches an unacceptable value, shut down line and follow the "Screen Replacement Instructions". A pressure gauge installed before and after the strainer in-line will indicate pressure loss due to clogging and may be used to determine when cleaning is required.

SCREEN REPLACEMENT

It is recommend that the system and strainer be depressurized before attempting any repair work. After removing all pressure, the system should be drained, any connections to the blow-off plug should be removed, and the following procedure should be used to replace the screen.

1. Attach cable or chain to strainer cover (1) and apply sufficient tension to prevent cover from dropping.
2. Remove bolts from cover.
3. Remove cover, clean and inspect gasket surface of cover.
4. Remove and discard old gasket.
5. Remove and clean or discard old screen.
6. Clean and inspect gasket surface of body. If gasket surface of cover or body is damaged, the damaged component must be replaced.
7. Push clean screen into position in body.
8. Position new gasket in place on body.
9. Line up screen and put cover in place on body.
10. Be sure gasket, bolt holes, and screen are properly aligned.
11. Put in bolts and nuts as required.
12. Tighten bolts, using "star" pattern to prevent damaging parts. Alternate tightening 180° apart. Tighten bolts sufficiently to stop leakage under test and service conditions.

"Apollo"[®]

LIQUID LEVEL GAUGE SELECTIONS L-6, L-7

LIQUID LEVEL GAUGE DIMENSIONS L-8, L-9

ROUGH BRONZE WATER GAUGES

20-100	L-10
20LF-100	L-10
20-150	L-10
20-200	L-10
20-250	L-10
20-300	L-10
20-350	L-10
20-410	L-10
20-600	L-10
20-700	L-10
20-800	L-10
24-300	L-12
24-350	L-12
24-600	L-12
24-650	L-12

ROUGH BRONZE-EXTENDED SHANK

21-100	L-11
21-200	L-11
21-250	L-11

STAINLESS STEEL LIQUID LEVEL GAUGES

23-400	L-11
23-450	L-11
23-650	L-11

POLISHED BRONZE WATER GAUGE

25-200	L-12
25-400	L-12
25-500	L-12
25-600	L-12

GLASS PROTECTORS L-13

REPAIR KITS L-15

LIQUID LEVEL GAUGES



GLOSSARY

AUTOMATIC / ASME AUTOMATIC / NON-AUTOMATIC WATER GAUGES:

An automatic water gauge is one that is equipped with ball checks in the valve body. In the event of glass breakage, these ball checks move horizontally, automatically seat to close the valves, shut off the flow of fluid, and help reduce the risk of property damage and/or personal injury from released fluid. An ASME automatic water gauge has a ball check in the bottom valve body that rises vertically to seat, and has a ball check in the top valve body that moves horizontally to seat.

BALL VALVE:

A bronze or stainless steel on-off valve utilizing a cored chrome-plated brass or stainless steel ball and Teflon seals. Easier to use than plug drains, petcocks, or needle drains.

CENTER TO CENTER:

The distance between the centers of the two NPT tapped holes in the vessel where the water gauge is to be attached.

CHAIN LEVER:

A lever handle activated by pulling a chain. Use for high, hard to reach installations.

EPDM:

Ethylene propylene rubber gauge glass packing, for temperatures -20°F to 350°F. Recommended for water, steam, silicone oils, ketones (MEK, acetone, etc...), alcohol, and brake fluid. Unsuitable for petroleum oils.

FRICITION WASHER:

The thin metal washer used to separate a packing from a metal surface to reduce friction. This in turn reduces the risk of inducing damaging torsional stress in the packing or gauge glass (torsional stress may reduce the useful life of the packing and gauge glass.)

GAUGE GLASS:

The transparent part of a water gauge assembly connected directly to a boiler, below and above the waterline, to indicate the level of water in the boiler.

GLASS PACKING:

The larger soft rubber-like or plastic ring, when compressed, provides a seal between the gauge glass and the valve body.

GLASS PACKING NUT:

The metal nut that the tubular gauge glass passes through. Tighten this nut to effect a seal between the glass packing and the gauge glass.

GRAPHITE:

Gaskets formed using graphite yarn. Suitable for temperatures up to 1200°F. Use when necessary for extended service at elevated temperatures.

GUARD RODS:

Guard rods are metal rods, mounted to the valve bodies or guard rod flange, that rise vertically to help protect the gauge glass from accidental breakage.

HANDWHEEL:

The aluminum or plastic (composition) handle. Also see chain lever.

HYPALON®:

TFE (an endless Tetrafluorethylene Aramid) gauge glass packing ring w/ Hypalon as a binder, suitable for temperatures from -20°F to 450°F. More difficult to seal than softer EPDM or Viton™ Rubbers. Use only when needed for superior acid resistance.

NEEDLE DRAIN:

A two piece drain (requires a wrench) that allows fluid to flow through an axial outlet.

PACKING GLAND:

The shouldered metal ring used in some models to supply extra compression to the gauge glass packing.

PETCOCK:

A brass or bronze tapered plug, metal seated on-off valve.

PLUG DRAIN:

A tapped opening (together with a threaded plug and drain seal) in the bottom of the lower valve body, to allow fluid to drain from the water gauge. This type drain requires a wrench for installation/removal. This type drain is not recommended for hazardous fluids (the fluid may come into contact with the operator).

SEAT WASHER:

The small white Teflon™ plastic ring sometimes used to seal the metal valve seat.

STEM PACKING:

The smaller soft rubber-like or plastic ring, when compressed, provides a seal between the valve stem and the valve body.

STEM PACKING NUT:

The metal nut that the valve stem passes through. Tighten this nut to effect a seal between the stem packing and the stem.

STEM PACKING WASHER:

The thin metal washer on the stem that serves as a friction washer and protects against extrusion of the packing.

TEFLON®:

Virgin PTFE fluoropolymer gauge glass packing or seat washer, for temperatures up to 450°F. More difficult to seal than Hypalon™. Use only when needed for more chemical resistance than Viton™ at elevated temperatures. Not recommended for hot fluorine, oxygen difluoride, or chlorine trifluoride.

TUBULAR GAUGE GLASS PROTECTOR:

A metal or impact-resistant plastic tube that fits over the gauge glass, to protect the glass from accidental breakage, and to help minimize the risk of personal injury and/or property damage. The use of a glass protector, where available, is recommended for all water gauge applications.

VITON™:

Fluorocarbon rubber (FKM) gauge glass packing, for temperatures -15°F to 400°F (up to 600°F for short periods.) Use for superior resistance at elevated temperatures. Recommended for petroleum oils, silicone oils, halogenated hydrocarbons (carbon tetrachloride, trichloroethylene), acids. Unsuitable for ketones (MEK, acetone), amines, anhydrous ammonia, hot hydrofluoric or chlorosulfonic acid.

* Not recommended for use with steam.

WATER GAUGE:

The gauge glass and its fittings for attachment.



WHAT IS A WATER GAUGE?

A water gauge is a device that allows the liquid level in a vessel to be visually inspected. Water gauges are required by the ASME Boiler and Pressure Code on steam boilers, and are also useful in many other applications, such as monitoring the amount of oil in an oil tank.

THINGS TO REMEMBER

Care must be given to ensure the proper selection of a water gauge. Special attention must be given to temperature/pressure requirements and to the service media (i.e. water, steam, oils, chemical agents, etc.). Some items to keep in mind:

- **PRESSURE RATINGS** may be influenced by limitations of the valve body, gauge glass, and gauge glass gasket. As temperatures increase, pressure ratings decrease. The larger the glass diameter and the longer the glass length, the lower the pressure rating. Refer to the **GAUGE GLASS PRESSURE AND TEMPERATURE TABLE** for detailed information.
- **TEMPERATURE RATINGS** may also be influenced by limitations of the valve body, gauge glass, & gauge glass gasket.
- Use **GUARD RODS** and **TUBULAR GAUGE GLASS PROTECTORS** to help protect glass from accidental breakage. Some applications require glass protectors
- Use **REDLINE** gauge glass where pressures permit to allow for easy reading of the gauge. Use large diameter (3/4") glass for increased visibility.
- Use **AUTOMATIC BALL CHECKS** to help minimize the risk of property damage or personal injury in the event of gauge glass breakage. Vertically rising automatic ball checks conforming to ASME requirements are available.
- Boilers operating above 400 psig require two water gauges.
- All water gauges on all steam boilers must be 1/2" NPT or larger.

A SPECIAL NOTE ABOUT CORROSION

Most problems with water gauge performance are associated with corrosion. Excessive corrosion may result in leakage, glass breakage, and premature valve failure. There are several things to watch for:

- Be sure all components (valve body, seals and packings, etc.) of the water gauge are constructed with materials compatible with the service medium. Non-standard packings for special applications may be ordered in our **WATER GAUGE REPAIR KITS**. See the "Compass Corrosion Guide" or equivalent for additional information.
- Elevated temperatures and pressures accelerate corrosion. You may need a stainless steel water gauge instead of bronze, or high pressure glass instead of standard, to achieve an acceptable service life.
- Operation and maintenance - check gauges daily for leaks, corrosion, and gauge glass clarity. Water gauges should be well illuminated and kept clean. Leaks may result in false waterline readings, may damage the gauge, and accelerate corrosion. The appearance of rust in the gauge glass is an indication of improper water treatment. See the **WATER GAUGE INSTALLATION INSTRUCTION (I-5387-00)** or the appropriate sections of the ASME Boiler and Pressure Vessel Code for additional information.
- Gauge Glass Corrosion - Gauge glass is attacked and dissolved in service by the fluid media, resulting in thinning of the wall and premature failure or replacement. Two factors determine the rate of attack: alkalinity and temperature. High alkalinity (high pH values) increases the rate of attack (a pH of 11.5 attacks glass at a rate of 30 times greater than a pH of 8.5). High temperatures increase the rate of attack (500°F water attacks glass 100 times faster than 265°F water). There is nothing that may be done to reduce the effects of temperature, but the effects of pH may be reduced by maintaining proper pH balance in the boiler water with chemical agents. Glass corrosion may also be decreased by avoiding exposure to water spray and drafts.



HOW TO SELECT A WATER GAUGE

1. SELECT A VALVE SERIES BASED UPON THE APPLICATION:

- Use 20-410 series for 90° handles or when working in close quarters.
- Use 20-600, 24-600, or 25-600 series (chain levers) where the water gauge is located beyond reach from the floor.
- Use 20-604/605 (bronze) or 23-650 (stainless steel) series expansion tank gauges when a shut-off is not required in the top valve (NEVER USE AN EXPANSION TANK GAUGE ON A BOILER!).
- Use 20-800 (bronze) or 23-450 (stainless steel) series expansion tank gauges to mount a pressure gauge or other instrument directly to the water gauge.
- Use 20-700 series expansion tank gauge for easier gauge glass replacement.
- Use 23-450 series stainless steel for superior corrosion resistance.
- Use polished gauges for a more elegant appearance.
- Use heavy pattern water gauges (such as 20-200/250, 24-300/350) for higher pressures. Be sure to verify gauge glass will withstand pressure by consulting the "Gauge Glass Service Rating Table".
- Use longer shank on NPT end when extra shank length is needed to penetrate an outer jacket or insulation (available on 21 series). Otherwise use a standard water gauge.

2. SELECT NON-AUTOMATIC, AUTOMATIC, OR ASME AUTOMATIC:

- Use automatic (horizontally seating) or ASME automatic (vertically rising to seat in lower valve body) ball checks where available to minimize the risk of personal injury and/or property damage in the event of gauge glass breakage. The sudden rush of steam and water seats the balls, thereby shutting off the escape of steam and water. There will however be slight leakage as required by certain codes.

3. SELECT A HANDWHEEL STYLE:

- Use aluminum handwheels for durability.
- Use plastic (composition) handwheels for reduced heat transfer.
- Use chain levers (not available on all models) when the water gauge is located beyond reach from the floor.

4. SELECT A GAUGE GLASS SIZE (DIAMETER):

- Use larger (3/4") diameter gauge glass where available for increased visibility.

5. SELECT A GAUGE GLASS TYPE (BASED ON PRESSURE REQUIREMENTS):

- Use redline glass for increased fluid level visibility.
- Use high pressure glass for high pressure applications.
- For economy use standard glass for low pressure applications.
- Replace the two digit suffix in the part number of the water gauge with -10 when selecting Redline or high pressure gauge glass (23 and 24 series have high pressure glass as standard).

*Please call Customer Service when non-standard (-10) devices are required.

6. SELECT GAUGE GLASS LENGTH:

- Select a default gauge glass length when possible (pages 8-9).
- Select a non-standard gauge glass length as needed, and replace the two digit suffix in the part number of the water gauge with -10. The longer the gauge glass, the lower the allowable pressure and temperature. Be sure to consult the "Gauge Glass Service Rating Table" for pressure and

temperature limits. When selecting non-standard gauge glass lengths, the gauge glass length is determined by subtracting the GL code from the desired "L" length

for the valve series number according to the tables on pages 8 and 9.

- For gauge glass longer than 72" it is necessary to use two or more water gauges of shorter length in an overlapped staggered tandem (i.e. for 100" of needed coverage, use two gauges of about 55" and install them parallel and staggered so as to overlap their individual coverage of 55" to get 100" total coverage).
- * Please call Customer Service when non-standard (-10) devices are required.

7. SELECT TUBULAR GAUGE GLASS PROTECTOR:

- For 5/8" diameter gauge glass, use I-2733-05
- For 3/4" diameter gauge glass, use I-2734-05
- Maximum protector length is 50"
- Protector not available on 23-300, 23-650, and 24-600 series.
- Available in brass only

8. SELECT DRAIN TYPE:

- Plug drain is standard on 23-600 series. Ball valve drain is standard on 23-400/450 and 24-300/350 series. Needle drain is standard on all others. Ball valve drain or petcock drain available on most models upon request.

9. SELECT A GAUGE GLASS PACKING MATERIAL:

- Use EPDM for most general applications, including steam service, for temperatures -20°F to 350°F. Recommended for water, steam, silicone oils, ketones (MEK, acetone, etc...), alcohol, and brake fluid. Unsuitable for petroleum oils. Comes standard on most models. EPDM is most economical.
- Use Viton® for superior resistance at elevated temperatures -15°F to 400°F (up to 600°F for short periods.) Recommended for petroleum oils, silicone oils, halogenated hydrocarbons (carbon tetrachloride, trichloroethylene), acids. Unsuitable for ketones (MEK, acetone), amines, anhydrous ammonia, hot hydrofluoric or chlorosulfonic acid. Viton® is about ten times more expensive than EPDM. * Not recommended for use with steam.
- Use Hypalon® for superior acid resistance at temperatures -20°F to 450°F. Has a shorter service life than EPDM and Viton® in standard, non-acid applications. More difficult to seal than softer EPDM or Viton®. Comes standard on 23 and 24 series. Hypalon® is equivalent to EPDM in cost.
- Use Teflon® for best chemical resistance, for temperatures up to 450°F. More difficult to seal than Hypalon®, Viton®, or EPDM. Use only when needed for more chemical resistance than Viton® at elevated temperatures. Not recommended for hot fluorine, oxygen difluoride, or chlorine trifluoride. Teflon® is about three times as expensive as EPDM.
- Use Graphite for superior service at elevated temperatures. More difficult to seal than EPDM or Viton® but has more universal application. Graphite is about ten times more expensive than EPDM. Remember, chemical resistance decreases as temperature increases. Consult "Compass Corrosion Guide" or equivalent.
- To order non-standard gauge glass packing, order the water gauge normally, then also order a "Water Gauge Repair Kit" ("Standard All" for EPDM, Hypalon® and Teflon®; "Viton® Gaskets Only" for Viton®, and "Graphite Gaskets Only" for graphite). Remove the pre-installed packing, and install the desired packing material



WATER GAUGE DO'S AND DON'TS

DO NOTS

- DO NOT use glass if it contains any scratches, chips, or any other visible signs of damage.
- DO NOT reuse any tubular glass or glass packings.
- DO NOT subject gauge glass to bending or torsional stresses.
- DO NOT over tighten glass packing nuts.
- DO NOT allow glass to touch any metal parts.
- DO NOT exceed the recommended pressure of the gauge or gauge glass.
- DO NOT clean the gauge or gauge glass while pressurized or in operation.

DO'S

- DO verify proper gauge has been supplied.
- DO examine gauge glass and packings carefully for damage before installation.
- DO install protective guards and utilize automatic ball checks where necessary to help prevent injury in case of glass breakage.
- DO inspect the gauge glass daily, keep maintenance records, and conduct routine replacements.
- DO protect glass from sudden changes in temperatures such as drafts, water spray, etc.

INSTALLATION

Only properly trained personnel should install and maintain water gauge glass and connections. Remember to wear safety gloves and glasses during installation. Before installing, make sure all parts are free of chips and debris.

1. Apply Teflon® tape or pipe dope to pipe threads. Install top gauge fitting (fitting without a drain valve) into the upper most tapping. Wrench tighten the fitting until it is snug and the glass outlet is pointing at five o'clock (about 1/8 turn from its final, downward vertical, position).
2. Install the bottom gauge fitting (the fitting with a drain valve) until it is snug and the glass outlet is pointing directly upward. Verify top and bottom fittings are threaded into the tapings the same number of turns (distance A= distance B).
3. Remove glass packing nut, friction washer (or packing gland and retaining ring, depending upon the model), and glass packing from the fittings, and place them, in the same order, on to both ends of the gauge glass. Push both packings about an inch up the gauge glass.
4. Gently insert one end of the glass into the top gauge fitting. Keeping the glass inside the top fitting, gently rotate the top gauge fitting clockwise, using wrench on valve wrench flats, until vertically aligned with the bottom gauge fitting, then insert glass into bottom fitting until glass bottoms out on the shoulder inside the bottom fitting.
5. Carefully raise glass about 1/16" and slide lower glass packing down until the glass packing contacts the lower gauge fitting. DO NOT allow the glass to remain in contact with any metal!
6. Carefully slide upper glass packing up as far as possible.
7. Hand tighten both glass packing nuts, then tighten 1/2 turn more by wrench. Tighten only enough to prevent leakage. DO NOT OVER TIGHTEN! If any leakage should occur, tighten slightly, a quarter turn at a time, checking for leakage after each turn.

MAINTENANCE

- Examine the gauge glass regularly for any signs of clouding, scratching, erosion, or corrosion. The glass should be inspected daily until the need for replacement becomes apparent. This will help establish the routine inspection and routine replacement schedules.

CLEANING

- Use commercial non-abrasive glass cleaners to keep glass clean. Use diluted acids such as Hydrochloric (muriatic) acid when regular cleaners do not seem to work. Do not use wire brushes or any other abrasive materials which could scratch the glass.

INSPECTION

- Examine the surface of the glass for scratches, corrosion, chips, cracks, surface flaws, or nicks. To do this, aim a very bright concentrated light at an angle of about 45 degrees. A defective glass will glisten as the light strikes imperfections. Glass which appears cloudy or roughened, and will not respond to cleaning, should be replaced.

STORING

- Keep gauge glass in original packaging until ready to install.

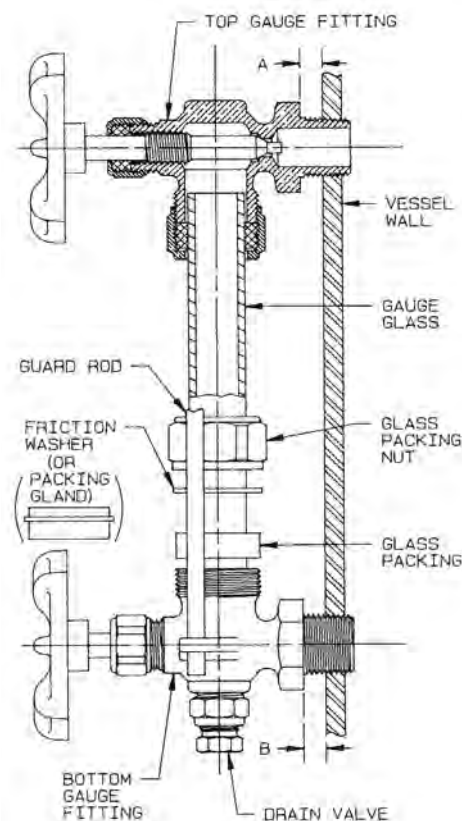



20-100 SERIES
STANDARD PATTERN



20-150 SERIES
PATTERN AUTOMATIC



20-200 SERIES
HEAVY PATTERN



20-250 SERIES
PATTERN AUTOMATIC



20-300 SERIES



20-350 SERIES
AUTOMATIC



20-410 SERIES
LEFT HAND ONLY



20-601 & 602 SERIES



20-604 & 605 SERIES





LIQUID LEVEL GAUGES

20-700 SERIES



20-800 SERIES



**23-450 SERIES
ASME AUTOMATIC**



23-600 SERIES



24-300 SERIES



24-600 SERIES



**25-200 SERIES
HEAVY PATTERN**



25-400 SERIES



**25-500 SERIES
AUTOMATIC**



25-600 SERIES





DIMENSIONS

- A - Overall length is found by adding this to dimension "L"
- B - Valve open total depth
- C - Valve closed total depth
- D - Handle diameter
- E - Maximum extension below lower arm centerline
- F - Maximum extension above upper arm centerline
- G - End of arm NPT to centerline of glass
- H - End of arm NPT to hex shoulder
- L - Centerline Length

Glass Length is "L" minus GL code
 Rod Length is glass length plus RL code

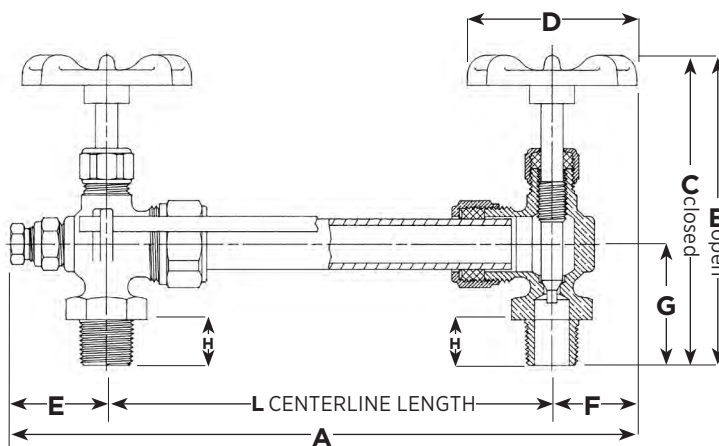

VALVE	PIPE SIZE	A	B	C	D	E	F	G	H	DEFAULT L	DEFAULT GLASS LENGTH	GL CODE	RL CODE
20-101	3/8	2.3	4.1	3.8	2.1	1.25	1.07	1.50	0.56	11.25	10	1.25	2
20-102	3/8	2.3	4.3	4.1	2.0	1.25	1.00	1.50	0.56	11.25	10	1.25	2
20-104	1/2	2.3	4.2	3.9	2.1	1.25	1.07	1.63	0.69	13.25	12	1.25	2
20LF-104	1/2	2.3	4.2	3.9	2.1	1.25	1.07	1.63	0.69	13.25	12	1.25	2
20-105	1/2	2.3	4.4	4.2	2.0	1.25	1.00	1.63	0.69	13.25	12	1.25	2
20LF-105	1/2	2.3	4.4	4.2	2.0	1.25	1.00	1.63	0.69	13.25	12	1.25	2
20-150*	1/2	2.3	4.2	3.9	2.1	1.25	1.07	1.63	0.69	13.25	12	1.25	2
20-151*	1/2	2.3	4.4	4.2	2.0	1.25	1.00	1.63	0.69	13.25	12	1.25	2
20-201	3/8	2.4	4.4	4.2	2.1	1.38	1.07	1.69	0.56	11.25	10	1.25	2
20-202	3/8	2.4	4.4	4.1	2.0	1.38	1.00	1.69	0.56	11.25	10	1.25	2
20-204	1/2	2.4	4.6	4.3	2.1	1.38	1.07	1.81	0.69	13.25	12	1.25	2
20-205	1/2	2.4	4.5	4.3	2.0	1.38	1.00	1.81	0.69	13.25	12	1.25	2
20-207	3/4	2.4	4.9	4.6	2.1	1.38	1.07	2.05	0.75	17.50	16	1.50	2.25
20-208	3/4	2.4	5.1	4.8	2.0	1.38	1.00	2.05	0.75	17.5	16	1.50	2.25
20-250	1/2	2.4	4.6	4.3	2.1	1.38	1.07	1.81	0.69	13.25	12	1.25	2
20-251*	1/2	2.4	4.5	4.3	2.0	1.38	1.00	1.81	0.69	13.25	12	1.25	2
20-253*	3/4	2.4	4.9	4.6	2.1	1.38	1.07	2.05	0.75	17.50	16	1.50	2.25
20-254*	3/4	2.4	5.1	4.8	2.0	1.38	1.00	2.05	0.75	17.50	16	1.50	2.25
20-304	1/2	2.3	5.3	5.1	2.1	1.25	1.07	2.20	0.69	14	12	2.00	1.25
20-305	1/2	2.3	5.5	5.3	2.0	1.25	1.00	2.20	0.69	14	12	2.00	1.25
20-307	3/4	2.3	5.0	5.4	2.1	1.25	1.07	2.06	0.69	18	16	2.00	1.25
20-308	3/4	2.3	5.4	5.0	2.0	1.25	1.00	2.06	0.69	18	16	2.00	1.25
20-350*	1/2	2.3	5.3	5.1	2.1	1.25	1.07	2.20	0.69	14	12	2.00	1.25
20-351*	1/2	2.3	5.5	5.3	2.0	1.25	1.00	2.20	0.69	14	12	2.00	1.25
20-353*	3/4	2.3	5.0	5.4	2.1	1.25	1.07	2.06	0.69	18	16	2.00	1.25
20-354*	3/4	2.3	5.4	5.0	2.0	1.25	1.00	2.06	0.69	18	16	2.00	1.25
20-410	1/2	2.3	2.1	1.9	1.8	1.42	0.86	2.09	1.25	13.25	12	1.25	NA
20-601	1/2	4.2	5.3	4.8	5.9	1.25	2.94	2.09	0.69	14	12	2.00	1.25
20-602	3/4	4.2	5.3	4.8	5.9	1.25	2.94	2.09	0.69	18	16	2.00	1.25
20-604*	1/2	2.1	4.6	4.3	2.1	1.38	0.69	1.81	0.69	13.25	12	1.25	2
20-605*	1/2	2.1	4.5	4.3	2.0	1.38	0.69	1.81	0.69	13.25	12	1.25	2
20-703	3/8	1.8	NA	NA	NA	1.25	0.53	1.50	0.56	11.25	10	1.25	2
20-704	1/2	1.8	NA	NA	NA	1.25	0.53	1.63	0.69	13.25	12	1.25	2
20-713	3/8	2.6	NA	NA	NA	1.25	1.36	1.5	0.56	11.25	10	1.25	2
20-714	1/2	2.6	NA	NA	NA	1.25	1.36	1.63	0.69	0.69	12	1.25	2
20-804*	1/2	2.1	4.6	4.3	2.1	1.38	0.75	1.81	0.69	13.25	12	1.25	2
20-805*	1/2	2.1	4.5	4.3	2.0	1.38	0.75	1.81	0.69	13.25	12	1.25	2



LIQUID LEVEL GAUGES

VALVE	PIPE SIZE	A	B	C	D	E	F	G	H	DEFAULT L	DEFAULT GLASS LENGTH	GL CODE	RL CODE
21-104	1/2	2.3	5.3	5.1	2.1	1.25	1.07	2.69	1.75	13.25	12	1.25	2
21-105	1/2	2.3	5.5	5.3	2.0	1.25	1.00	2.69	1.75	13.25	12	1.25	2
21-150*	1/2	2.3	5.0	4.8	2.1	1.25	1.07	2.69	1.75	13.25	12	1.25	2
21-151*	1/2	2.3	5.5	5.3	2.0	1.25	1.00	2.69	1.75	13.25	12	1.25	2
21-204	1/2	2.4	5.6	5.4	2.1	1.38	1.07	2.88	1.75	13.25	12	1.25	2
21-205	1/2	2.4	5.6	5.3	2.0	1.38	1.00	2.88	1.75	13.25	12	1.25	2
21-250*	1/2	2.4	5.6	5.4	2.1	1.38	1.07	2.88	1.75	13.25	12	1.25	2
21-251*	1/2	2.4	5.6	5.4	2.0	1.38	1.00	2.88	1.75	13.25	12	1.25	2
23-401	1/2	4.1	5.6	5.6	2.1	3	1.07	2.13	0.69	14	12	2	3.25
23-402	1/2	4.0	5.6	5.6	2.0	3	1.00	2.13	0.69	14	12	2	3.25
23-404	3/4	4.1	5.6	5.1	2.1	3	1.07	2.09	0.75	18	16	2	3.25
23-405	3/4	4.0	5.6	5.1	2.0	3	1.00	2.09	0.75	18	16	2	3.25
23-450**	1/2	4.1	5.6	5.1	2.1	3	1.07	2.13	0.69	14	12	2	3.25
23-451**	1/2	4.0	5.6	5.1	2.0	3	1.00	2.13	0.69	14	12	2	3.25
23-453**	3/4	4.1	5.6	5.1	2.1	3	1.07	2.09	0.75	18	16	2	3.25
23-454**	3/4	4.0	5.6	5.1	2.0	3	1.00	2.09	0.75	18	16	2	3.25
23-651	1/2	1.8	4.6	4.4	2.1	1.065	0.69	2.50	0.69	14	12	2	1.25
23-654	3/4	1.8	4.6	4.4	2.1	1.065	0.69	2.50	0.75	14	12	2	1.25
24-301	1/2	4.1	5.8	5.3	2.1	3	1.07	2.09	0.69	14	12	2	1.25
24-302	1/2	4.0	5.8	5.3	2.0	3	1.00	2.09	0.69	14	12	2	1.25
24-304	3/4	4.1	5.8	5.3	2.1	3	1.07	2.09	0.69	18	16	2	1.25
24-305	3/4	4.0	5.6	5.1	2.0	3	1.00	2.09	0.69	18	16	2	1.25
24-350**	1/2	4.1	5.8	5.3	2.1	3	1.07	2.09	0.69	14	12	2	1.25
24-351**	1/2	4.0	5.6	5.1	2.0	3	1.00	2.09	0.69	14	12	2	1.25
24-353**	3/4	4.1	5.8	5.3	2.1	3	1.07	2.09	0.69	18	16	2	1.25
24-354**	3/4	4.0	5.6	5.1	2.0	3	1.00	2.09	0.69	18	16	2	1.25
24-601	1/2	5.9	5.3	4.8	5.8	3	2.88	2.09	0.69	14	12	2	0.875
24-602	3/4	5.9	5.3	4.8	5.8	3	2.88	2.09	0.69	18	16	2	0.875
24-651**	1/2	5.9	5.3	4.8	5.8	3	2.88	2.09	0.69	14	12	2	0.875
24-652**	3/4	5.9	5.3	4.8	5.8	3	2.88	2.09	0.69	18	16	2	0.875
25-201	3/8	2.4	4.4	4.2	2.1	1.38	1.07	1.69	0.56	11.25	10	1.25	2
25-202	3/8	2.4	4.4	4.1	2.0	1.38	1.00	1.69	0.56	11.25	10	1.25	2
25-204	1/2	2.4	4.6	4.3	2.1	1.38	1.07	1.81	0.69	13.25	12	1.25	2
25-205	1/2	2.4	4.5	4.3	2.0	1.38	1.00	1.81	0.69	13.25	12	1.25	2
25-207	3/4	2.4	4.9	4.6	2.1	1.38	1.07	2.05	0.75	17.25	16	1.25	2
25-208	3/4	2.4	5.1	4.8	2.0	1.38	1.00	2.05	0.75	17.25	16	1.25	2
25-404	1/2	2.3	5.3	5.1	2.1	1.25	1.07	2.20	0.69	14	12	2	1.25
25-405	1/2	2.3	5.5	5.3	2.0	1.25	1.00	2.20	0.69	14	12	2	1.25
25-407	3/4	2.3	5.4	5.0	2.1	1.25	1.07	2.06	0.69	18	16	2	1.25
25-408	3/4	2.3	5.4	5.0	2.0	1.25	1.00	2.06	0.69	18	16	2	1.25
25-501*	1/2	2.3	5.3	5.1	2.1	1.25	1.07	2.20	0.69	14	12	2	1.25
25-502*	1/2	2.3	5.5	5.3	2.0	1.25	1.00	2.20	0.69	14	12	2	1.25
25-504*	3/4	2.3	5.4	5.0	2.1	1.25	1.07	2.06	0.69	18	16	2	1.25
25-505*	3/4	2.3	5.4	5.0	2.0	1.25	1.00	2.06	0.69	18	16	2	1.25
25-601	1/2	5.9	5.3	4.8	5.9	2.94	2.94	2.09	0.69	14	12	2	1.25
25-602	3/4	5.9	5.3	4.8	5.9	2.94	2.94	2.09	0.69	18	16	2	1.25

* Automatic
 ** Conforms to ASME Check Requirements
 NSF/ANSI 372 Lead Free

Suffix Key
 -00 Standard set includes top & bottom valves, glass and rods
 -01 Top valve only
 -02 Bottom valve only
 -03 Top & Bottom valves only (no glass or rods)
 -10 For special gauges with non-standard glass, rods, and/or gaskets.

LIQUID LEVEL GAUGES



ROUGH BRONZE WATER GAUGE



SERIES NO.	RATING (SUBJECT TO LIMITATION OF GAUGE GLASS)
20-100/20LF-100	125 psig @ 350°F, 300 psig @ 100°F
20-150	125 psig @ 350°F, 300 psig @ 100°F
20-200	200 psig @ 400°F, 400 psig @ 100°F
20-250	200 psig @ 400°F, 400 psig @ 100°F
20-300	200 psig @ 400°F, 400 psig @ 100°F
20-350	200 psig @ 400°F, 400 psig @ 100°F
20-410	125 psig @ 350°F, 300 psig @ 100°F
20-601, 602	250 psig @ 400°F, 500 psig @ 100°F
20-604, 605	200 psig @ 400°F, 400 psig @ 100°F
20-700	125 psig @ 350°F, 300 psig @ 100°F
20-100	200 psig @ 400°F, 400 psig @ 100°F

SERIES NO.	PIPE SIZE	STANDARD GLASS O.D. & LENGTH	GLASS SEAL	STEM PACKING	STANDARD GLASS TYPE	HANDLE	WT./100
20-101-00	3/8	5/8 x 10	EPDM Rubber	Teflon*	Regular	Aluminum	145
20-102-00	3/8	5/8 x 10	EPDM Rubber	Teflon*	Regular	Composite	145
20-104-00	1/2	5/8 x 12	EPDM Rubber	Teflon*	Regular	Aluminum	160
20LF-104-00	1/2	5/8 x 12	EPDM Rubber	Teflon*	Regular	Aluminum	160
20-105-00	1/2	5/8 x 12	EPDM Rubber	Teflon*	Regular	Composite	160
20LF-105-00	1/2	5/8 x 12	EPDM Rubber	Teflon*	Regular	Composite	160
20-150-00*	1/2	5/8 x 12	EPDM Rubber	Teflon*	Regular	Aluminum	160
20-151-00*	1/2	5/8 x 12	EPDM Rubber	Teflon*	Regular	Composite	160
20-201-00	3/8	5/8 x 10	EPDM Rubber	Teflon*	Regular	Aluminum	185
20-202-00	3/8	5/8 x 10	EPDM Rubber	Teflon*	Regular	Composite	189
20-204-00	1/2	5/8 x 12	EPDM Rubber	Teflon*	Regular	Aluminum	205
20-205-00	1/2	5/8 x 12	EPDM Rubber	Teflon*	Regular	Composite	205
20-207-00	3/4	3/4 x 16	EPDM Rubber	Teflon*	Regular	Aluminum	270
20-208-00	3/4	3/4 x 16	EPDM Rubber	Teflon*	Regular	Composite	270
20-250-00*	1/2	5/8 x 12	EPDM Rubber	Teflon*	Regular	Aluminum	195
20-251-00*	1/2	5/8 x 12	EPDM Rubber	Teflon*	Regular	Composite	200
20-253-00*	3/4	3/4 x 16	EPDM Rubber	Teflon*	Regular	Aluminum	355
20-254-00*	3/4	3/4 x 16	EPDM Rubber	Teflon*	Regular	Composite	360
20-304-00	1/2	5/8 x 12	EPDM Rubber	Teflon*	Regular	Aluminum	260
20-305-00	1/2	5/8 x 12	EPDM Rubber	Teflon*	Regular	Composite	270
20-307-00	3/4	3/4 x 16	EPDM Rubber	Teflon*	Regular	Aluminum	345
20-308-00	3/4	3/4 x 16	EPDM Rubber	Teflon*	Regular	Composite	365
20-350-00*	1/2	5/8 x 12	EPDM Rubber	Teflon*	Regular	Aluminum	265
20-351-00*	1/2	5/8 x 12	EPDM Rubber	Teflon*	Regular	Composite	265
20-353-00*	3/4	3/4 x 16	EPDM Rubber	Teflon*	Regular	Aluminum	360
20-354-00*	3/4	3/4 x 16	EPDM Rubber	Teflon*	Regular	Composite	365
20-410-00 (LH)	1/2	5/8 x 12	EPDM Rubber	Teflon*	Regular	Aluminum	180
20-601-00	1/2	5/8 x 12	EPDM Rubber	Teflon*	Regular	Chain	370
20-602-00	3/4	3/4 x 16	EPDM Rubber	Teflon*	Regular	Chain	435
20-604-00*	1/2	5/8 x 12	EPDM Rubber	Teflon*	Regular	Aluminum	155
20-605-00*	1/2	5/8 x 12	EPDM Rubber	Teflon*	Regular	Composite	175
20-703-00	3/8	5/8 x 10	EPDM Rubber	N/A	Regular	N/A	120
20-704-00	1/2	5/8 x 12	EPDM Rubber	N/A	Regular	N/A	135
20-713-00	3.8	5/8 x 12	EPDM Rubber	N/A	Regular	N/A	135
20-714-00	1/2	5/8 x 10	EPDM Rubber	N/A	Regular	N/A	135
20-804-00*	1/2	5/8 x 12	EPDM Rubber	Teflon*	Regular	Aluminum	160
20-805-00*	1/2	5/8 x 12	EPDM Rubber	Teflon*	Regular	Composite	160

* Automatic
NSF/ANSI 372 Lead Free



ROUGH BRONZE WATER GAUGE WITH EXTENDED SHANK

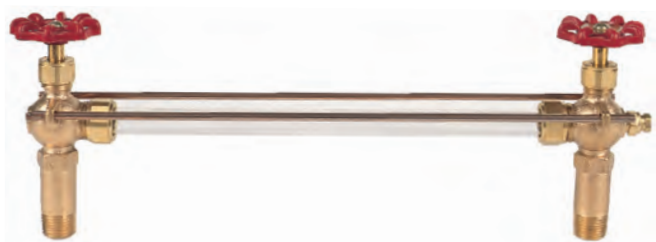

SERIES NO.	RATING (SUBJECT TO LIMITATION OF GAUGE GLASS)
21-100	125 psig @ 350°F, 300 psig @ 100°F
21-150	125 psig @ 350°F, 300 psig @ 100°F
21-200	200 psig @ 400°F, 400 psig @ 100°F
21-250	200 psig @ 400°F, 400 psig @ 100°F

SERIES NO.	PIPE SIZE	STANDARD GLASS O.D. & LENGTH	GLASS SEAL	STEM PACKING	HANDLE	STANDARD GLASS TYPE	WT./100	SHANK LENGTH
21-104	1/2	5/8 x 12	EPDM Rubber	Teflon*	Aluminum	Regular	185	1-3/4
21-105	1/2	5/8 x 12	EPDM Rubber	Teflon*	Composite	Regular	197	1-3/4
21-150*	1/2	5/8 x 12	EPDM Rubber	Teflon*	Aluminum	Regular	195	1-3/4
21-151*	1/2	5/8 x 12	EPDM Rubber	Teflon*	Composite	Regular	207	1-3/4
21-204	1/2	5/8 x 12	EPDM Rubber	Teflon*	Aluminum	Regular	215	1-3/4
21-205	1/2	5/8 x 12	EPDM Rubber	Teflon*	Composite	Regular	219	1-3/4
21-250*	1/2	5/8 x 12	EPDM Rubber	Teflon*	Aluminum	Regular	215	1-3/4
21-251*	1/2	5/8 x 12	EPDM Rubber	Teflon*	Composite	Regular	215	1-3/4

* Automatic

STAINLESS STEEL LIQUID LEVEL GAUGE



SERIES NO.	RATING (SUBJECT TO LIMITATION OF GAUGE GLASS)
23-401	500 psig @ 450°F
23-450	500 psig @ 450°F
23-650	250 psig @ 406°F

SERIES NO.	PIPE SIZE	STANDARD GLASS O.D. & LENGTH	GLASS SEAL	STEM PACKING	HANDLE	STANDARD GLASS TYPE	WT./100
23-401	1/2	5/8 x 12	PTFE w/Hypalon*	Braided PTFE w/Aramid	Aluminum	High Pressure	385
23-402	1/2	5/8 x 12	PTFE w/Hypalon*	Braided PTFE w/Aramid	Composition	High Pressure	385
23-404	3/4	3/4 x 16	PTFE w/Hypalon*	Braided PTFE w/Aramid	Aluminum	High Pressure	450
23-405	3/4	3/4 x 16	PTFE w/Hypalon*	Braided PTFE w/Aramid	Composition	High Pressure	450
23-450**	1/2	5/8 x 12	PTFE w/Hypalon*	Braided PTFE w/Aramid	Aluminum	High Pressure	390
23-451**	1/2	5/8 x 12	PTFE w/Hypalon*	Braided PTFE w/Aramid	Composition	High Pressure	390
23-453**	3/4	3/4 x 16	PTFE w/Hypalon*	Braided PTFE w/Aramid	Aluminum	High Pressure	455
23-454**	3/4	3/4 x 16	PTFE w/Hypalon*	Braided PTFE w/Aramid	Composition	High Pressure	455
23-651	1/2	5/8 x 12	PTFE w/Hypalon*	Teflon*	Aluminum	High Pressure	225
23-654	3/4	5/8 x 12	PTFE w/Hypalon*	Teflon*	Aluminum	High Pressure	225

** Conforms to ASME Check Requirements

LIQUID LEVEL GAUGES



ROUGH BRONZE LIQUID LEVEL GAUGE

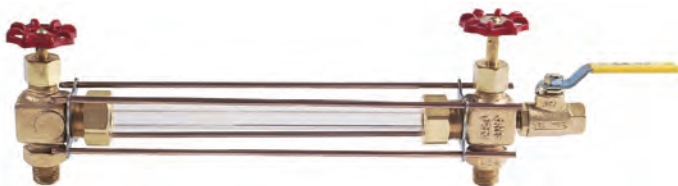

SERIES NO.	RATING (SUBJECT TO LIMITATION OF GAUGE GLASS)
24-300	250 psig @ 400°F, 500 psig @ 100°F
24-350	250 psig @ 400°F, 500 psig @ 100°F
24-600	250 psig @ 400°F, 500 psig @ 100°F
24-650	250 psig @ 400°F, 500 psig @ 100°F
24-750	250 psig @ 400°F, 500 psig @ 100°F
24-850	250 psig @ 400°F, 500 psig @ 100°F

SERIES NO.	PIPE SIZE	STANDARD GLASS O.D. & LENGTH	GLASS SEAL	STEM PACKING	HANDLE	STANDARD GLASS TYPE	WT./100
24-301	1/2	5/8 x 12	PTFE w/Hypalon*	Braided PTFE w/Aramid	Aluminum	High Pressure	425
24-302	1/2	5/8 x 12	PTFE w/Hypalon*	Braided PTFE w/Aramid	Composition	High Pressure	425
24-304	3/4	3/4 x 16	PTFE w/Hypalon*	Braided PTFE w/Aramid	Aluminum	High Pressure	490
24-305	3/4	3/4 x 16	PTFE w/Hypalon*	Braided PTFE w/Aramid	Composition	High Pressure	490
24-350**	1/2	5/8 x 12	PTFE w/Hypalon*	Braided PTFE w/Aramid	Aluminum	High Pressure	425
24-351**	1/2	5/8 x 12	PTFE w/Hypalon*	Braided PTFE w/Aramid	Composition	High Pressure	425
24-353**	3/4	3/4 x 16	PTFE w/Hypalon*	Braided PTFE w/Aramid	Aluminum	High Pressure	490
24-354**	3/4	3/4 x 16	PTFE w/Hypalon*	Braided PTFE w/Aramid	Composition	High Pressure	490
24-601	1/2	5/8 x 12	PTFE w/Hypalon*	Braided PTFE w/Aramid	Chain	High Pressure	515
24-602	3/4	3/4 x 16	PTFE w/Hypalon*	Braided PTFE w/Aramid	Chain	High Pressure	580
24-651**	1/2	5/8 x 12	PTFE w/Hypalon*	Braided PTFE w/Aramid	Chain	High Pressure	515
24-652**	3/4	3/4 x 16	PTFE w/Hypalon*	Braided PTFE w/Aramid	Chain	High Pressure	580

** Conforms to ASME Check Requirements

POLISHED BRONZE WATER GAUGE

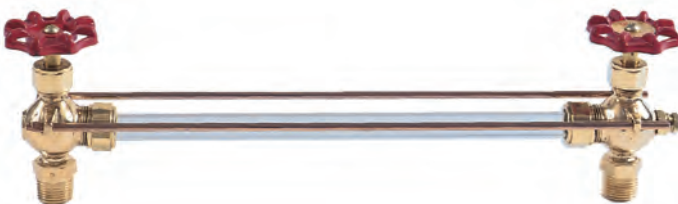

SERIES NO.	RATING (SUBJECT TO LIMITATION OF GAUGE GLASS)
25-200	200 psig @ 400°F, 400 psig @ 100°F
25-400	125 psig @ 350°F, 300 psig @ 100°F
25-500	200 psig @ 400°F, 400 psig @ 100°F
25-600	250 psig @ 400°F, 500 psig @ 100°F

SERIES NO.	PIPE SIZE	STANDARD GLASS O.D. & LENGTH	GLASS SEAL	STEM PACKING	HANDLE	STANDARD GLASS TYPE	WT./100
25-201	3/8	5/8 x 10	EPDM rubber	PTFE w/Hypalon*	Aluminum	Regular	180
25-202	3/8	5/8 x 10	EPDM rubber	PTFE w/Hypalon*	Composition	Regular	185
25-204	1/2	5/8 x 12	EPDM rubber	PTFE w/Hypalon*	Aluminum	Regular	190
25-205	1/2	5/8 x 12	EPDM rubber	PTFE w/Hypalon*	Composition	Regular	190
25-207	3/4	3/4 x 16	EPDM rubber	PTFE w/Hypalon*	Aluminum	Regular	290
25-208	3/4	3/4 x 16	EPDM rubber	PTFE w/Hypalon*	Composition	Regular	295
25-404#	1/2	5/8 x 12	EPDM rubber	PTFE w/Hypalon*	Aluminum	Regular	285
25-405#	1/2	5/8 x 12	EPDM rubber	PTFE w/Hypalon*	Composition	Regular	285
25-407	3/4	3/4 x 16	EPDM rubber	PTFE w/Hypalon*	Aluminum	Regular	350
25-408	3/4	3/4 x 16	EPDM rubber	PTFE w/Hypalon*	Composition	Regular	350
25-501*	1/2	5/8 x 12	EPDM rubber	PTFE w/Hypalon*	Aluminum	Regular	290
25-502*	1/2	5/8 x 12	EPDM rubber	PTFE w/Hypalon*	Composition	Regular	290
25-504*	3/4	3/4 x 16	EPDM rubber	PTFE w/Hypalon*	Aluminum	Regular	355
25-505*	3/4	3/4 x 16	EPDM rubber	PTFE w/Hypalon*	Composition	Regular	355
25-601	1/2	5/8 x 12	EPDM rubber	Graphite w/Aramid	Chain	Regular	335
25-602	3/4	3/4 x 16	EPDM rubber	Graphite w/Aramid	Chain	Regular	350

* Automatic

Valve bodies made from brass bar stock.



TUBULAR GAUGE GLASS PROTECTOR

- Reduces the risk of injury and damage from broken exploding glass.
- Made to fit most water gauges.
- Priced according to length and application.
- Maximum protector length of 50".
- Tubular gauge glass protector not available on the 23-400, 23-450, 23-600, 23-650, 24-300, 24-600 and 24-650 series.
- Maximum of 50" length.
Give series number and centerline distance "L" when ordering.

STANDARD GLASS PROTECTOR LENGTHS

PART NUMBER	SIZE	LENGTH
I273305L12	PROTECTOR,ASSY,5/8"GAUGE GLS,	L=12",CU
I273305L24	PROTECTOR,ASSY,5/8"GAUGE GLS,	L=24",CU
I273305L36	PROTECTOR,ASSY,5/8"GAUGE GLS,	L=36",CU
I273305L48	PROTECTOR,ASSY,5/8"GAUGE GLS,	L=48",CU
I273305L50	PROTECTOR,ASSY,5/8"GAUGE GLS,	L=50",CU
I273405L12	PROTECTOR,ASSY,3/4"GAUGE GLS,	L=12",CU
I273405L24	PROTECTOR,ASSY,3/4"GAUGE GLS,	L=24",CU
I273405L36	PROTECTOR,ASSY,3/4"GAUGE GLS,	L=36",CU
I273405L48	PROTECTOR,ASSY,3/4"GAUGE GLS,	L=48",CU
I273405L50	PROTECTOR,ASSY,3/4"GAUGE GLS,	L=50",CU

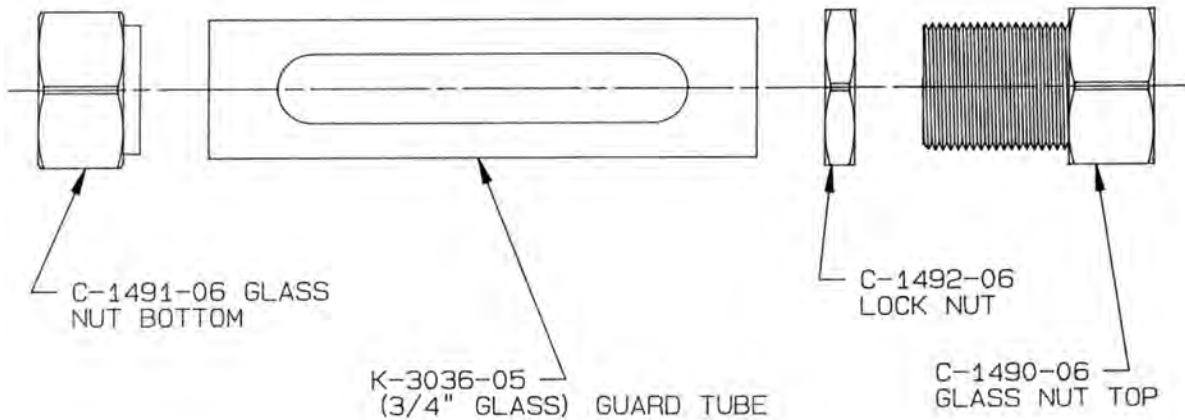

LIQUID LEVEL GAUGES



GAUGE PRESSURE-TEMPERATURE RATINGS

MAXIMUM RECOMMENDED WORKING PRESSURE (PSI)



REGULAR/STANDARD GLASS

Example: 9858R12 = 5/8" OD x 12" L Regular Glass



HIGH PRESSURE GLASS

Example: 9834I16 = 3/4" OD x 16" L High Pressure Glass



REDLINE GLASS

Example: 9834P14 = 3/4" OD x 14" L Redline Glass

TYPE	OD SIZE	TOL.	WALL	TOL.	LENGTH	TEMP. TO 150°F, NO CORROSION	STEAM BOILER SERVICE TO 450°F
Standard	5/8	+0, -3/64	5/64	+1/64	8	210	100
Standard	5/8	+0, -3/64	5/64	+1/64	10	210	100
Standard	5/8	+0, -3/64	5/64	+1/64	12	205	100
Standard	5/8	+0, -3/64	5/64	+1/64	14	200	100
Standard	5/8	+0, -3/64	5/64	+1/64	16	195	100
Standard	5/8	+0, -3/64	5/64	+1/64	18	190	100
Standard	5/8	+0, -3/64	5/64	+1/64	24	180	100
Standard	5/8	+0, -3/64	5/64	+1/64	30	175	**
Standard	5/8	+0, -3/64	5/64	+1/64	36	165	**
Standard	5/8	+0, -3/64	5/64	+1/64	48	140	**
Standard	5/8	+0, -3/64	5/64	+1/64	60	120	**
Standard	5/8	+0, -3/64	5/64	+1/64	72	100	**
Standard	3/4	+0, -3/64	3/32	+1/64	8	210	100
Standard	3/4	+0, -3/64	3/32	+1/64	10	210	100
Standard	3/4	+0, -3/64	3/32	+1/64	12	205	100
Standard	3/4	+0, -3/64	3/32	+1/64	14	200	100
Standard	3/4	+0, -3/64	3/32	+1/64	16	195	100
Standard	3/4	+0, -3/64	3/32	+1/64	18	190	100
Standard	3/4	+0, -3/64	3/32	+1/64	24	180	100
Standard	3/4	+0, -3/64	3/32	+1/64	30	175	**
Standard	3/4	+0, -3/64	3/32	+1/64	36	165	**
Standard	3/4	+0, -3/64	3/32	+1/64	48	140	**
Standard	3/4	+0, -3/64	3/32	+1/64	60	120	**
Standard	3/4	+0, -3/64	3/32	+1/64	72	100	**
High Pressure	5/8	+0, -1/32	3/32	+1/64	8	435	320
High Pressure	5/8	+0, -1/32	3/32	+1/64	10	420	315
High Pressure	5/8	+0, -1/32	3/32	+1/64	12	410	305
High Pressure	5/8	+0, -1/32	3/32	+1/64	14	390	295
High Pressure	5/8	+0, -1/32	3/32	+1/64	16	375	285
High Pressure	5/8	+0, -1/32	3/32	+1/64	18	360	280
High Pressure	5/8	+0, -1/32	3/32	+1/64	20	350	270
High Pressure	5/8	+0, -1/32	3/32	+1/64	24	320	255
High Pressure	5/8	+0, -1/32	3/32	+1/64	30	280	**
High Pressure	5/8	+0, -1/32	3/32	+1/64	36	245	**
High Pressure	5/8	+0, -1/32	3/32	+1/64	48	195	**
High Pressure	5/8	+0, -1/32	3/32	+1/64	60	150	**
High Pressure	5/8	+0, -1/32	3/32	+1/64	72	100	**
High Pressure	3/4	+0, -1/32	3/32	+1/64	8	425	315
High Pressure	3/4	+0, -1/32	3/32	+1/64	10	410	310
High Pressure	3/4	+0, -1/32	3/32	+1/64	12	400	300
High Pressure	3/4	+0, -1/32	3/32	+1/64	14	385	290
High Pressure	3/4	+0, -1/32	3/32	+1/64	16	370	280
High Pressure	3/4	+0, -1/32	3/32	+1/64	18	355	275
High Pressure	3/4	+0, -1/32	3/32	+1/64	20	345	265
High Pressure	3/4	+0, -1/32	3/32	+1/64	24	315	250
High Pressure	3/4	+0, -1/32	3/32	+1/64	30	275	**
High Pressure	3/4	+0, -1/32	3/32	+1/64	36	240	**
High Pressure	3/4	+0, -1/32	3/32	+1/64	48	190	**
High Pressure	3/4	+0, -1/32	3/32	+1/64	60	145	**
High Pressure	3/4	+0, -1/32	3/32	+1/64	72	100	**
Redline	5/8	+0, -1/32	3/32	+1/64	8	370	285
Redline	5/8	+0, -1/32	3/32	+1/64	10	345	280
Redline	5/8	+0, -1/32	3/32	+1/64	12	335	280
Redline	5/8	+0, -1/32	3/32	+1/64	14	325	275
Redline	5/8	+0, -1/32	3/32	+1/64	16	315	270
Redline	5/8	+0, -1/32	3/32	+1/64	18	305	265
Redline	5/8	+0, -1/32	3/32	+1/64	20	290	265
Redline	5/8	+0, -1/32	3/32	+1/64	24	265	255
Redline	5/8	+0, -1/32	3/32	+1/64	30	235	**
Redline	5/8	+0, -1/32	3/32	+1/64	36	205	**
Redline	5/8	+0, -1/32	3/32	+1/64	48	165	**
Redline	5/8	+0, -1/32	3/32	+1/64	60	125	**
Redline	5/8	+0, -1/32	3/32	+1/64	72	90	**
Redline	3/4	+0, -1/32	3/32	+1/64	8	360	280
Redline	3/4	+0, -1/32	3/32	+1/64	10	340	275
Redline	3/4	+0, -1/32	3/32	+1/64	12	330	275
Redline	3/4	+0, -1/32	3/32	+1/64	14	320	270
Redline	3/4	+0, -1/32	3/32	+1/64	16	310	265
Redline	3/4	+0, -1/32	3/32	+1/64	18	300	260
Redline	3/4	+0, -1/32	3/32	+1/64	20	285	260
Redline	3/4	+0, -1/32	3/32	+1/64	24	260	250
Redline	3/4	+0, -1/32	3/32	+1/64	30	230	**
Redline	3/4	+0, -1/32	3/32	+1/64	36	200	**
Redline	3/4	+0, -1/32	3/32	+1/64	48	160	**
Redline	3/4	+0, -1/32	3/32	+1/64	60	125	**
Redline	3/4	+0, -1/32	3/32	+1/64	72	90	**

** Maximum recommended length in this service is 24."



REPAIR KITS

The standard* repair kits contain glass packing, stem packing, friction washers, seat washers, and drain washer applicable to the particular valve. Three types of glass packing, EPDM rubber, Hypalon®, and Virgin Teflon®, are included in the standard repair kit. For oil related service, Fluorelastomer (Viton®) glass gasket sets are available. For severe applications, graphite glass gaskets and stem packing sets are available for each model.

REPAIR KIT ORDERING INFORMATION

20	-	00X	-	0X
DESIGNATION		KIT TYPE		KIT NUMBER
20-00	-	WATER GAUGE REPAIR KIT		
		1	-	STANDARD ALL
		2	-	VITON GASKETS ONLY
		3	-	GRAPHITE GASKETS ONLY

EXAMPLE:
 *20-001-01 = Standard Kit described above
 20-002-01 = Viton Glass Gaskets Only
 20-003-01 = Graphite Glass Gaskets Only

REPAIR KIT APPLICATIONS

KIT	APPLICATIONS - WATER GAUGE SERIES
20-001-01 20-003-01	20-101, 20-102, 20-104, 20-105, 20-150, 20-151, 20-405, 20-406, 20-407, 20-408, 20-410, 21-101, 21-102, 21-104, 21-105, 21-150, 21-151,
20-001-02 20-003-02	20-201, 20-202, 20-204, 20-205, 20-250, 20-251, 20-304, 20-305, 20-350, 20-351, 20-604, 20-605, 20-804, 20-805, 21-204, 21-205, 21-250, 21-251, 25-201, 25-202, 25-204, 25-205, 25-404, 25-405, 25-501, 25-502
20-001-03 20-003-03	20-207, 20-208, 20-253, 20-254, 20-307, 20-308, 20-353, 20-354, 25-207, 25-208, 25-407, 25-408, 25-504, 25-505
20-001-04 20-003-04	20-601, 25-601
20-001-05 20-003-05	20-602, 25-602
20-001-06 20-003-06	20-703, 20-704, 20-713, 20-714
20-001-07 20-003-07	23-401, 23-402, 23-450, 23-451
20-001-08 20-003-08	20-405, 20-406, 20-407, 20-408
20-001-09 20-003-09	23-404, 23-405, 23-453, 23-454
20-001-10 20-003-10	23-651, 23-654
20-001-11 20-003-11	24-301, 24-302, 24-350, 24-351, 24-450, 24-451
20-001-12 20-003-12	24-304, 24-305, 24-353, 24-354, 24-453, 24-454
20-001-13 20-003-13	24-601, 24-651, 24-751, 24-851
20-001-14 20-003-14	24-602, 24-652, 24-752, 24-852
20-002-01	20-101, 20-102, 20-104, 20-105, 20-150, 20-151, 20-201, 20-202, 20-204, 20-205, 20-250, 20-251, 20-304, 20-305, 20-350, 20-351, 20-405, 20-406, 20-407, 20-408, 20-410, 20-601, 20-604, 20-605, 20-703, 20-704, 20-713, 20-714, 20-804, 20-805, 21-101, 21-102, 21-104, 21-105, 21-150, 21-151, 21-204, 21-205, 21-250, 21-251, 23-651, 23-654, 25-201, 25-202, 25-204, 25-205, 25-404, 25-405, 25-501, 25-502, 25-601
20-002-02	20-207, 20-208, 20-253, 20-254, 20-307, 20-308, 20-353, 20-354, 25-207, 25-208, 25-407, 25-408, 25-504, 25-505, 20-602, 25-602
20-002-03	23-401, 23-402, 23-450, 23-451, 24-301, 24-302, 24-350, 24-351, 24-450, 24-451, 24-601, 24-651, 24-751, 24-851
20-002-04	23-404, 23-405, 23-453, 23-454, 24-304, 24-305, 24-353, 24-354, 24-453, 24-454, 24-602, 24-652, 24-752, 24-852



REPAIR KITS

SELECTION INSTRUCTIONS

It is helpful to determine the following information when ordering a repair kit.

- Model number (if not available describe gauge, i.e. material, # guard rods, NPT size, etc.)
- Glass O.D. and type
- Handle type
- Service media, temperature, and pressure

If you know the model number just examine the "Repair Kit Applications" chart to select kit number for your valve. To order the standard kit, or Viton®, or graphite gaskets, assemble the ordering matrix for the desired kit number.

If you are unable to determine model number please determine the above information and call customer service for assistance.

For replacement glass please determine the above information in addition to the "L" dimension and call customer service. "L" dimension (center to center height of water gauge inlets).

WATER GAUGE & GAUGE GLASS REPAIR KIT INSTRUCTIONS

Only properly trained personnel should install, maintain and repair water gauge glass and connections. Remember to wear safety gloves and glasses during installation/repair. Before installing, make sure all parts are free of chips and debris.

DISASSEMBLY/ASSEMBLY

1. Close water gauge valves. If necessary drain vessel to eliminate leakage during repair. Drain gauge glass using drain valve or plug.
2. Completely loosen both glass packing nuts.
3. Gently raise gauge glass until bottom of gauge glass clears lower fitting.
4. Using a wrench attached to the hex flats on the upper fitting, lift glass and packing nut then rotate the fitting and glass 1/8 turn counterclockwise.
5. Carefully remove the gauge glass from the upper fitting. Remove all glass packing, packing nuts, washers and packing glands, noting their positions on the glass.
6. Clean and inspect gauge glass and fittings for any wear, erosion, cracks or debris. Any damaged components must be replaced.
7. If it is desired, the stem packing can be replaced by removing the handle(s) then the stem packing nut. Remove old packing and stem packing washer if applicable. Install new packing in stem packing nut and reuse stem packing washer as applicable.
8. To replace seat washers (where applicable) the system must be drained. After removing the stem packing nut reinstall handle and remove stem by opening valve. Cut off old seat washer and install new seat washer using appropriate size tube driver.
9. Install stem until it seats. Remove handle and install stem packing nut with packing inside. Tighten stem packing nut until snug using wrench
10. Place glass packing nut, friction washer (or packing gland and retaining ring, depending upon the model), and new glass packing, in the same order as found, on to both ends of the gauge glass. Push both packings about an inch up the gauge glass.
11. Gently insert one end of the glass into the top gauge fitting. Keeping the glass inside the top fitting, gently rotate the top gauge fitting clockwise, using wrench on valve hex flats, until vertically aligned with the bottom gauge fitting. Insert glass into bottom fitting until glass bottoms out on the shoulder inside the bottom fitting.
12. Carefully raise glass about 1/16" and slide lower glass packing down until the glass packing bottoms out. DO NOT allow the glass to remain in contact with any metal!
13. Carefully slide upper glass packing up as far as possible.
14. Hand tighten both glass packing nuts, then tighten 1/2 turn more by wrench. Tighten only enough to prevent leakage. DO NOT OVER TIGHTEN! If any leakage should occur, tighten slightly, a quarter turn at a time, checking for leakage after each turn.

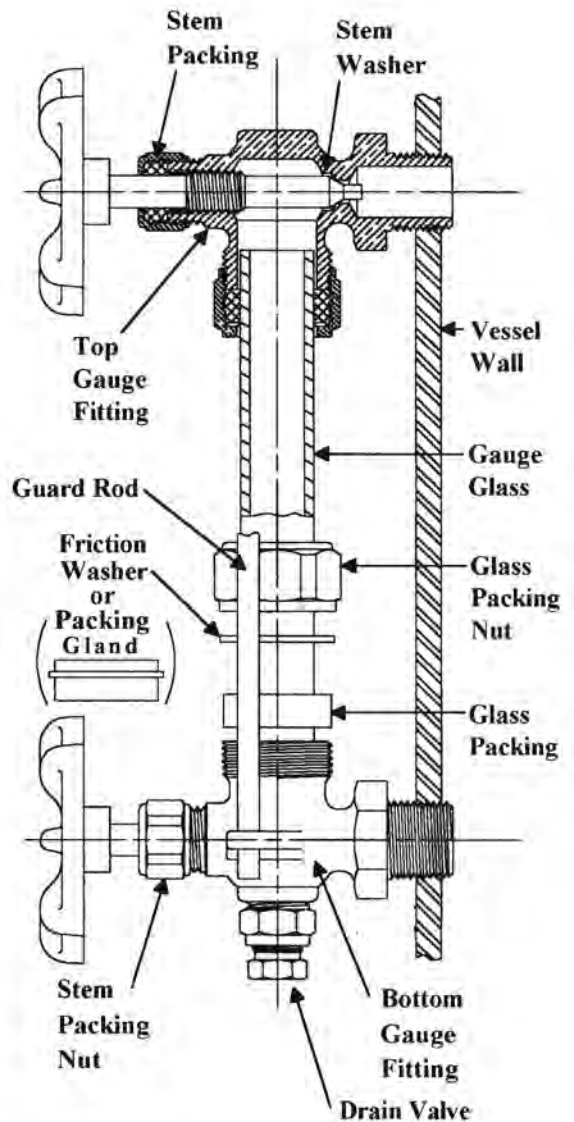

LIQUID LEVEL GAUGES

"Apollo"®

PLUMBING SPECIALTIES

26-100/300/700	M-2
26-500	M-2
27-400	M-2

AIR COCKS

41	M-3
----	-----

HEAVY/EXTRA HEAVY AIR & STEAM COCKS

41-100	M-4
41-200	M-4
41-250	M-4

HOSE END AIR COCKS

44-100	M-4
--------	-----

GAS VALVES/COCKS

50-200	M-5
50-400	M-5
50-500	M-5
50-600	M-5
50-700	M-5
50-800	M-5
51-100	M-6
52-100	M-6
52-200	M-6
55-300	M-6

DRAIN VALVES

35-200	M-7
31-200	M-7
31-500	M-7
31-400	M-7
31-600	M-8
31-700	M-8
35-300	M-8

PLUMBING SPECIALTIES

26-100/26-300 SERIES
COMPRESSION GAUGE COCKS



26-300

For draining expansion tanks, other liquid storage vessels. For condensate only. Standard finish is satin brass.

FEATURES

- 26-100: Rated up to 125 psig
- 26-300: Soft Metal Seat/Stuffing Box Rated up to 250 psig at 400°F
- 26-310: Stainless Steel Ball Seat/Stuffing Box Rated up to 250 psig at 400°F
- 26-700: TFE Seat, Rated up to 250 psig at 400°F

SERIES NUMBER	PIPE SIZE (IN.)	WT./100 (LB.)	WHEEL TYPE
26-104-01	1/2	28.3	ALUMINUM
26-105-01	1/2	30.0	COMPOSITION
26-304-01	1/2	40.0	ALUMINUM
26-305-01	1/2	44.0	COMPOSITION
26-307-01	3/4	49.0	ALUMINUM
26-308-01	3/4	51.7	COMPOSITION
26-314-01	1/2	40.0	ALUMINUM
26-315-01	1/2	44.0	COMPOSITION
26-704-01	1/2	78.0	ALUMINUM
26-705-01	1/2	82.0	COMPOSITION

**26-100 series is not available with packing nut
Specify the following suffix for finish: Polished Brass -28 (example: 26-304-28)*

26-500 SERIES
LEVER OPERATED COMPRESSION COCK



For draining expansion tanks or other liquid storage vessels where the drain port is beyond reach. Spring loaded lever provides positive closure to 250 psig at 300.

FEATURES

- Bronze Body B584 UNS C84400
- Stainless Steel Closure Spring
- PTFE Soft Seat
- Graphite Stem Packing
- Zinc Plated "S" Hook on Lever
- Optional 6 Foot Chain
- Rated up to 250 psig

SERIES NUMBER	PIPE SIZE (IN.)	WT./100 (LB.)	CHAIN
26-504-01	1/2	110	
26-504-02	1/2	112	6' chain

27-400 SERIES
STEAM GAUGE SIPHON



27-401



27-402

For pressure gauge protection. Condensate trap protects dial pressure gauges from direct steam contact.

FEATURES

- Heavy Gauge Seamless Brass Tubing
- 27-401 is 180° loop, 27-402 is 90° loop
- Service Rating: 250 psig Saturated Steam, 400 psig at 100°F

SERIES NUMBER	PIPE SIZE (IN.)	WT./100 (LB.)
27-401-01	1/4	44.0
27-402-01	1/4	40.0

41 SERIES
AIR COCKS











An economical way to shut-off air lines. Standard spring bottom (-01) with 5/32" port are tested at 80 psig. Optional nut bottom (-04) with 1/8" port are suitable for pressures to 200 psig. Various handle configurations available.









FEATURES

- Standard Spring Bottom (5/32" Port)
- Air Cocks Tested at 80 psi
- Optional Nut Bottom (1/8" port) Suitable to 200 psig
- Standard Satin Brass Finish
- Maximum temperature is 500° F

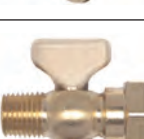
OPTIONS

- (-01) Standard Spring Bottom
- (-04) Nut Bottom

	SERIES NUMBER	SIZE (IN.)	WT./100 (LB.)
	TEE HANDLE ROUND SHOULDER		
	41-060	1/8	12.8
	41-070	1/4	13.0
	TEE HANDLE HEXAGON SHOULDER		
	41-080	3/8	17.0
	41-090	1/2	20.0
	LEVER HANDLE ROUND SHOULDER		
	41-120	1/8	13.1
	41-130	1/4	14.2
	LEVER HANDLE HEXAGON SHOULDER		
	41-140	3/8	17.0
	41-150	1/2	22.9
	TEE HANDLE DOUBLE MALE THREAD		
	41-180	1/8	14.0
	41-190	1/4	17.9
	41-203	3/8	20.0
	41-210	1/2	33.1
	LEVER HANDLE DOUBLE MALE THREAD		
	41-220	1/8	14.0
	41-230	1/4	18.5
	41-240	3/8	19.1
	41-251	1/2	31.3
	TEE HANDLE BIBB NOSE		
	41-260	1/8	14.5
	41-270	1/4	16.3
	41-280	3/8	33.3
	41-330	1/2	36.0
	LEVER HANDLE BIBB NOSE		
	41-290	1/8	16.5
	41-300	1/4	15.0
	41-310	3/8	32.1
	41-320	1/2	36.0
	TEE HANDLE DOUBLE FEMALE		
	41-370	1/8	13.0
	41-380	1/4	14.0
	41-390	3/8	26.0
	41-391	1/2	27.0
	TEE HANDLE MALE & FEMALE		
	41-400	1/8	13.0
	41-410	1/4	14.0
	41-420	3/8	21.0
	41-421	1/2	26.0

	SERIES NUMBER	SIZE (IN.)	WT./100 (LB.)
	LEVER HANDLE DOUBLE FEMALE		
	41-430	1/8	14.8
	41-440	1/4	13.0
	41-450	3/8	23.0
	41-451	1/2	27.0
	LEVER HANDLE MALE & FEMALE		
	41-460	1/8	15.2
	41-470	1/4	15.0
	41-480	3/8	23.0
	41-481	1/2	27.0
	TEE HANDLE MALE & FEMALE HEX SHOULDER		
	41-490	1/8	17.0
	41-500	1/4	15.0
	41-510	3/8	23.0
	41-511	1/2	25.0
	LEVER HANDLE MALE & FEMALE HEX SHOULDER		
	41-520	1/8	14.0
	41-530	1/4	15.0
	41-540	3/8	22.1
	41-541	1/2	27.0
	TEE HANDLE DOUBLE FEMALE HEX SHOULDER		
	41-550	1/8	17.0
	41-560	1/4	17.0
	41-570	3/8	25.0
	41-571	1/2	28.3
	LEVER HANDLE DOUBLE FEMALE HEX SHOULDER		
	41-580	1/8	15.0
	41-590	1/4	18.2
	41-600	3/8	24.0
	41-601	1/2	28.8
	TEE HANDLE STRAIGHT NOSE HEX SHOULDER		
	41-630	1/8	15.7
	41-640	1/4	15.0
	LEVER HANDLE STRAIGHT NOSE HEX SHOULDER		
	41-650	1/8	14.0
	41-660	1/4	15.0

41 SERIES

HEAVY AND EXTRA HEAVY PATTERN AIR AND STEAM COCKS



Heavy and extra heavy patterns for higher pressure applications.

FEATURES

- Satin Brass Finish
- Spring Bottom (-01) is Tested at 100psi
- Rated for Air Pressure up to 250 psig with Nut Version
- Extra Heavy Pattern Rated for 150 SWP - Nut Bottom Only

OPTIONS

- (-01) Standard Spring Bottom
- (-04) Nut Bottom

SERIES NUMBER	SIZE (IN.)	WT./100 (LB.)
HEAVY PATTERN TEE HANDLE DOUBLE FEMALE		
41-102-01	1/4	28.00
LEVER HANDLE DOUBLE FEMALE		
41-103-01	1/4	27.00
EXTRA HEAVY PATTERN TEE HANDLE DOUBLE FEMALE		
41-200-01	1/8	32.00
41-202-01	1/4	32.00
TEE HANDLE DOUBLE FEMALE HEXAGON SHOULDER		
41-222-01	1/4	38.00
TEE HANDLE MALE AND FEMALE		
41-250-01	1/4	20.00

44-100 SERIES

HOSE END AIR COCKS



Interior diameter hose sizes: 3/8" to 7/16"

FEATURES

- 3/16" Port; Rated 25 psig
- Satin Brass Finish

SERIES NUMBER	SIZE (IN.)	WT./100 (LB.)
44-101-01	1/8	19
44-102-01	1/4	22
44-103-01	3/8	23
44-104-01	1/2	25

GCB (50) SERIES
MANUAL MAIN CONTROL VALVES

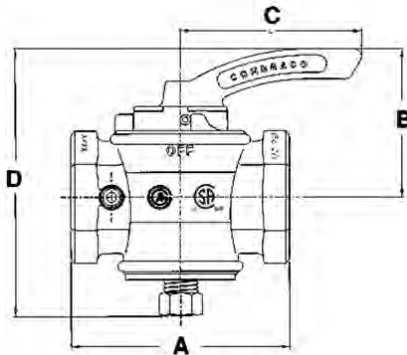

CSA design certified for 1/2 psig and temperatures from 32° to 125°F. Complies to ANSI Z 21.15, CSA 9.1

FEATURES

- 100% Factory Tested at 10 psig
- Bronze Construction, Stainless Steel Springs
- Capacities to 7.8 Million BTU/Hour
- Equal Female Inlet/Outlet
- Bosses on Both Sides are Drilled and Tapped. Only One Side is Plugged

SERIES NUMBER	SIZE (IN.)	BTU/HR.	WT./100 (LB.)	DIMENSIONS (IN.)			
				A	B	C	D
50-203*	1/2	800,000	88	2.50	1.44	1.72	2.75
50-303	3/4	1,310,000	156	2.94	1.69	2.06	3.50
50-403	1	2,100,000	197	3.94	2.19	2.87	3.87
50-503	1-1/4	3,250,000	300	3.66	2.75	3.16	4.69
50-603	1-1/2	3,700,000	478	4.37	3.31	3.50	5.75
50-703	2	7,300,000	845	5.44	3.72	4.50	6.75
50-803	2-1/2	7,800,000	1000	5.87	3.72	4.50	6.75

*1/2" size is not CSA certified

HANDLE SUFFIX POSITION

SIZE PILOT (IN.)	W	X	Y	Z
1/8 NPT	01	02	03	04
1/4 NPT	05	06	07	08

All main burner valves furnished with 1/8" NPT pilot tapping. Valves 1" and larger can be furnished with 1/4" NPT pilot tapping.

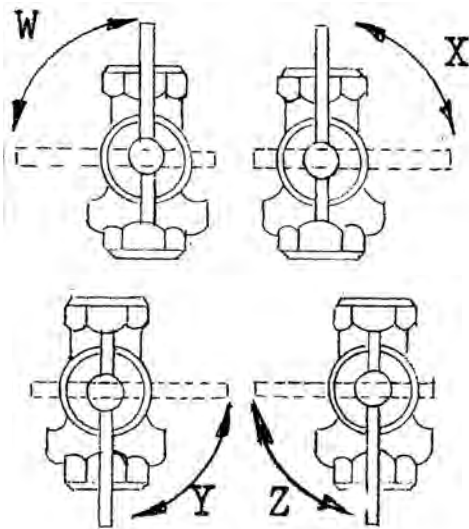

GC (51) SERIES
GAS SERVICE COCKS



Tee or lever handle cocks; CSA design certified. In sizes 1/4" to 3/4".

FEATURES

- Capacities: 117,000 to 749,000 BTU/Hour
- Certified to ANSI Z21.15 and CSA 9.1 (1/2 psig at Temperatures from 32°F to 125°F)
- Accepted for Use by City of New York Department of Buildings MEA 45-90-M

SERIES NUMBER	PIPE SIZE (IN.)	WT./100 (LB.)	CAPACITY (BTU/HR.)
T-HANDLE W/STOP			
51-103-01	1/4	35	117,000
51-104-01	3/8	47	274,600
51-105-01	1/2	54	274,000
LEVER HANDLE W/STOP			
51-107-01	3/8	50	274,600

GC2 (52) SERIES
GAS SERVICE COCKS



Available with tee head, flat head, square head or lever head in sizes from 1/4" to 1". Wrench operated and tested at 125 psig.

FEATURES

- High Pressure Rating
- Capacities: 117,000 to 749,000 BTU/Hour
- Accepted for Use by City of New York Department of Buildings MEA 45-90-M
- Maximum Temperature: 500°F

SERIES NUMBER	SIZE (IN.)	WT./100 (LB.)	SERIES NUMBER	SIZE (IN.)	WT./100 (LB.)
T-HEAD			SQUARE HEAD		
52-101-01	1/4	32.0	52-301-01	1/4	31.0
52-102-01	3/8	29.0	52-302-01	3/8	28.0
52-103-01	1/2	45.0	52-303-01	1/2	43.0
52-104-01	3/4	65.8	52-304-01	3/4	62.7
52-105-01	1	92.9	52-305-01	1	90.0
FLAT HEAD			LEVER HEAD		
52-201-01	1/4	30.0	52-401-01	1/4	34.3
52-202-01	3/8	28.0	52-402-01	3/8	31.0
52-203-01	1/2	43.0	52-403-01	1/2	46.0
52-204-01	3/4	57.0	52-404-01	3/4	66.7
52-205-01	1	90.6	52-405-01	1	97.0

GCR (55) SERIES
GAS COCK WITH THROTTLE ADJUSTMENT



FEATURES

- Certified to ANSI Z21.15 and CSA 9.1 (1/2 psig at 32°F to 125°F)
- Thread Size: 1/4" Male x 1/4" Female

SERIES NUMBER	SIZE (IN.)	WT./100 (LB.)
55-302-01	1/4 M x 1/4 F	33

HB (35-200) SERIES
COMPRESSION BIBB FAUCET



Features heavy pattern with large flow path.

FEATURES

- Solid Bronze Construction
- Both Models have 3/4" Hose Connection
- Aluminum Handwheel
- Made in USA

SERIES NUMBER	PIPE SIZE (IN.)	WT./100 (LB.)
35-201-01	1/2	58.3
35-202-01	3/4	57.0

BD90 (31-200/31-500) SERIES
90° DRAIN VALVE

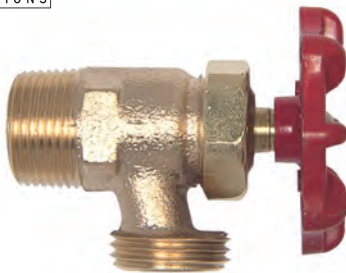

For deluxe water heaters and low pressure boilers.

FEATURES

- Maximum Rated Pressure: 200 psig
- Maximum Rated Temperature: 250°F
- Red Aluminum Wheel Handle
- 31-200 Series Heavy Pattern, 3/4" MNPT Inlet
- 31-500 Series Standard Pattern, 1/2" MNPT Inlet with I.D. of NPT Thread Machined for 1/2" Copper Pipe
- (-04P) Optional Plain Finish Handle
- Made in USA

SERIES NUMBER	LF SERIES NUMBER	WT./100 (LB.)	SHANK LENGTH (IN.)	INLET (IN.)
31-202-04	31LF-202-04	43.00	5/8	3/4 MNPT
31-212-04	31LF-212-04	46.50	15/16	3/4 MNPT
31-501-04	31LF-501-04	31.00	5/8	1/2 MNPT/1/2 Sweat

BDT (31-400) SERIES
COMBINATION TEE & DRAIN VALVE



Permits supplying and draining of water through a single tank tapping and meets CSA requirements.

FEATURES

- All Cast Bronze Body
- Aluminum Handwheel
- No Handle: Screwdriver Slot Stem Option
- Maximum Rated Pressure: 200 psig
- Maximum Rated Temperature: 250°F
- 3/4" FNPT inlet x 3/4" Male Hose End x 3/4" FNPT Side Outlet
- Made in USA

SERIES NUMBER	LF SERIES NUMBER	WT./100 (LB.)	HANDLE
31-401-04	31LF-401-04	62.00	Aluminum Wheel - Red
31-401-04P	31LF-401-04P	62.00	Aluminum Wheel - Plain
31-401-13	31LF-401-13	62.00	Slotted Stem

BD (31-600/31-700) SERIES
ANGLED BODY WATER HEATER DRAIN



31-600
MALE NPT



31-700
FEMALE NPT

All drains are equipped with Conbraco packing seal assuring easy turning stem and leak proof drain. Various shank lengths available. Meets CSA requirements.

FEATURES

- All Cast Bronze Body
- Maximum Rated Pressure: 200 psig
- Maximum Rated Temperature: 250° F
- 31-600: 3/4" MNPT Inlet
- 31-700: 1/2" or 3/4" FNPT Inlet
- Made in USA

HANDLE SUFFIX

-04	Aluminum Wheel - Red
-04P	Aluminum Wheel - Plain
-13	Slotted Stem

**Not all variations available in all sizes. Contact customer service.*

SERIES NUMBER	SHANK LENGTH (IN.)	INLET (IN.)	WT./100 (LB.)
31-600	5/8"	3/4" MNPT	27.3
31-601	3/4"	3/4" MNPT	36.0
31-602	1"	3/4" MNPT	35.0
31-604	1-1/4"	3/4" MNPT	43.0
31-606	1-1/2"	3/4" MNPT	49.5
31-607	1-3/4"	3/4" MNPT	48.0
31-608	2	3/4" MNPT	52.0
31-609	2-1/4"	3/4" MNPT	52.0
31-610	2-1/2"	3/4" MNPT	57.2
31-611	2-3/4"	3/4" MNPT	60.0
31-612	3"	3/4" MNPT	66.3
31-700		1/2" FNPT	39.0
31-701		3/4" FNPT	37.0

BDQ (35-300) SERIES
BIBB FAUCET BALL VALVE

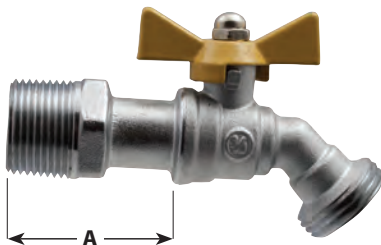

Features heavy pattern with large opening. Ideal for boiler and water heater drains, general liquid dispensing and drainage. The new 45° spout design allows for easier hose connection access.

FEATURES

- Chrome Plated Finish
- Pressure Rating: 200 psig liquid
- Maximum Temperature: 250°F
- Apollo International™

DIMENSIONS

SERIES NUMBER	SIZE (IN.)	A (IN.)	INLET (IN.)	OUTLET (IN.)	WT./100 (LB.)
35-301-03	1/2	1-1/2	1/2 sweat/thrd connector	0.75-11.5 NHR hose	38.4
35-302-03	3/4	1-3/4	3/4 thrd connector	0.75-11.5 NHR hose	44.5



Conbraco Industries, Inc. warrants, to its initial purchaser only, that its products which are delivered to this initial purchaser will be of the kind described in the order or price list and will be free of defects in workmanship or material for a period of FIVE years from the date of delivery to you, our initial purchaser. This warranty applies to Apollo brand product with "Made in the USA" markings only.

Should any failure to conform to this warranty appear within FIVE years after the date of the initial delivery to our initial purchaser, Conbraco will, upon written notification thereof and substantiation that the goods have been stored, installed, maintained and operated in accordance with Conbraco's recommendations and standard industry practice, correct such defects by suitable repair or replacement at Conbraco's own expense.

APOLLO INTERNATIONAL PRODUCTS: Conbraco Industries, Inc. warrants its International products, to its initial purchaser only, that its international products which are delivered to this initial purchaser will be of the kind described in the order or price list and will be free of defects in workmanship or material for a period of TWO years from the date of delivery to you, our initial purchaser.

THIS WARRANTY IS EXCLUSIVE AND IS IN LIEU OF ANY IMPLIED WARRANTY OF MERCHANTABILITY, FITNESS FOR A PARTICULAR PURPOSE OR OTHER WARRANTY OF QUALITY, WHETHER EXPRESSED OR IMPLIED, EXCEPT THE WARRANTY OF TITLE AND AGAINST PATENT INFRINGEMENT. Correction of non-conformities, in the manner and for the period of time provided above, shall constitute fulfillment of all liabilities of Conbraco to our initial purchaser, with respect to the goods, whether based on contract, negligence, strict tort or otherwise. It is the intention of Conbraco Industries, Inc. that no warranty of any kind, whether expressed or implied shall pass through our initial purchaser to any other person or corporation.

LIMITATION OF LIABILITY: Conbraco Industries, inc. SHALL NOT UNDER ANY CIRCUMSTANCES BE LIABLE FOR SPECIAL OR CONSEQUENTIAL DAMAGES SUCH AS, BUT NOT LIMITED TO, DAMAGES OR TO LOSS OF OTHER PROPERTY OR EQUIPMENT, LOSS OF PROFITS OR REVENUE, COST OF CAPITAL, COST OF PURCHASED OR REPLACEMENT GOODS, OR CLAIMS OF CUSTOMERS OF OUR INITIAL PURCHASER. THE REMEDIES OF OUR INITIAL PURCHASER, AND ALL OTHERS, SET FORTH HEREIN, ARE EXCLUSIVE, AND THE LIABILITY OF CONBRACO WITH RESPECT TO SAME SHALL NOT, EXCEPT AS EXPRESSLY PROVIDED HEREIN, EXCEED THE PRICE OF THE GOODS UPON WHICH SUCH LIABILITY IS BASED.

* It is the end user's responsibility to confirm that items intended for use satisfy local codes and standards.

TERMS AND CONDITIONS OF SALE

- Payment: 2% 10th prox. Net 30 days.
- All prices F.O.B. shipping point with freight allowed on shipments of 750 pounds and/or \$5,000 net minimum to all shipping points within the United States excluding Alaska and Hawaii. No freight allowed on Air Freight or Parcel Post shipments. Claims for shortages must be made within 10 days of receipt of material. Our responsibility ends when a receipt is furnished us by the carrier.
- No Invoice Rendered For Less Than \$50.00.
- No freight will be allowed on Air Freight, Air Express, Parcel Post or U.P.S. shipments.
- All Conbraco products may be combined to make sufficient weight for full freight allowance.
- Phone order quoted prices are subject to correction. Prices and designs are subject to change without notice.
- Orders for material or special design or specification are made to customer's order and are not subject to cancellation or return.
- All goods returned to us will not be accepted unless a full explanation has been made and our written authorized permission obtained in advance. All goods returned - if accepted - will be credited at invoice price, less 30% for service and rehandling charges, plus shipping expenses.
- We reserve the right to adjust orders to box quantities.

"Apollo"®

PRODUCT CATALOG

PHONE: (704) 841-6000

FAX: (704) 841-6020

Regional Management List

now available online at:

<http://conbra.co/rmlist>

CPCA9000 07/18 7,500

Customer Service (704) 841-6000
www.apollovalves.com

