

INSTALLER'S GUIDE

18-HB22D1-12

ALL phases of this installation must comply with NATIONAL,
STATE AND LOCAL CODES

Models:

BAYHTR1504BRKC	BAYHTR1515BRKB	BAYHTR1525BRKA
BAYHTR1504LUGB	BAYHTR1516BRKA	BAYHTR3510LUGC
BAYHTR1505BRKC	BAYHTR1517BRKA	BAYHTR3515LUGC
BAYHTR1505LUGB	BAYHTR1519BRKB	BAYHTR3517LUGA
BAYHTR1508BRKC	BAYHTR1520BRKB	
BAYHTR1508LUGB	BAYHTR1521BRKB	
BAYHTR1510BRKC	BAYHTR1522BRKA	
BAYHTR1510LUGB	BAYHTR1523BRKA	

Supplementary Electric Heaters

for TEM4, TEM6 and TEM8 Air Handlers

IMPORTANT— This Document is customer property and is to remain with this unit. Please return to service information pack upon completion of work.

⚠ WARNING: HAZARDOUS VOLTAGE - DISCONNECT POWER BEFORE SERVICING

GENERAL

This accessory electric heater is designed to provide power directly to the unit from the accessory heater's power supply eliminating the need for additional circuits. The power and control wiring use a single polarized plug to connect the heater and the unit. See the Heater Data table on page 4 for the number of circuits required.

1. Check the unit heater label to confirm that the selected Heater is approved for use with this unit in the installed configuration. For some heaters, a corresponding secondary nameplate label is included. Place the label within the heater data table on the air handler nameplate. This is shown in Figure 7.
2. Check the components received for damage. Report any defects or shortages to the transportation company immediately.
3. Be sure the power supply agrees with the listing shown on heater nameplate.

⚠ WARNING

THIS PRODUCT CONTAINS FIBERGLASS WOOL INSULATION! FIBERGLASS DUST AND CERAMIC FIBERS ARE BELIEVED BY THE STATE OF CALIFORNIA TO CAUSE CANCER THROUGH INHALATION. GLASSWOOL FIBERS MAY ALSO CAUSE RESPIRATORY, SKIN, OR EYE IRRITATION.

PRECAUTIONARY MEASURES

- Avoid breathing fiberglass dust
- Use a NIOSH approved dust/mist respirator
- Avoid contact with the skin or eyes. Wear long-sleeved, loose fitting clothing, gloves, and eye protection.
- Wash clothes separately from other clothing, rinse washer thoroughly.
- Operations, such as sawing, blowing, tear-out, and spraying may generate fiber concentrations requiring additional respiratory protection. Use the appropriate NIOSH approved respirator in these situations.

FIRST AID MEASURES

EYE CONTACT: FLUSH EYES WITH WATER TO REMOVE DUST. IF SYMPTOMS PERSIST, SEEK MEDICAL ATTENTION.

SKIN CONTACT: WASH AFFECTED AREA GENTLY WITH SOAP AND WARM WATER AFTER HANDLING.

INSTALLER'S GUIDE

NOTE: Illustrations may vary from the actual unit by cabinet and heater size.

INSTALLATION

1. Remove Blower Access panel.
2. Locate heater knock-out plate at rear of control box.
3. With tin snips, cut the four tabs located at the center points of the edges of knock-out plate.
4. Discard knock-out plate.



Figure 1

5. Slide heater into opening.
6. Secure heater to control box opening with four screws located at the corners of the mount plate. See Figure 2 for screw locations. (One not visible in photo)



Figure 2

8. Locate the two locking tabs on the top panel of the air handler; shown as "Left" and "Center" in the drawing.
9. Slide the breaker plate assembly into the appropriate tab. Rotate the breaker assembly into place as shown in image 4.

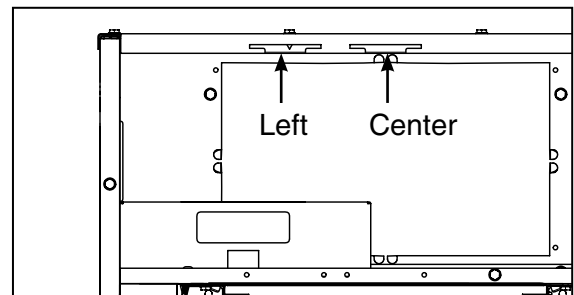

IMPORTANT: The left side breaker mount location must be used for TEM8A0B24/30 air handlers, 25 kW heaters, and Single Power Entry Kits.
The center breaker mount location should be used for all other 4-20 kW heater installations.

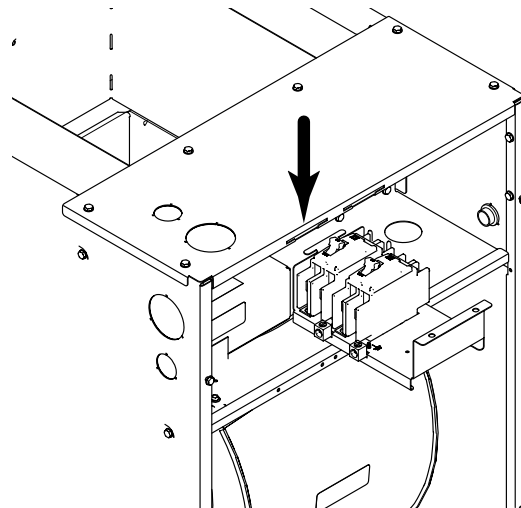

Figure 3 - Left side breaker mount location shown

10. Secure breaker/pull disconnect mount plate with two screws along the bottom of plate.
11. Make all wiring connections per applicable field wiring diagrams. All installations must conform to national, state and local electrical codes.
12. Connect the polarized harness plug to the polarized plug on the heater.
13. Refer to the heater minimum airflow chart or the unit rating nameplate for the appropriate minimum blower speed tap to be used with the approved heater installed.
14. Connect all field wiring per air handler installation guide.

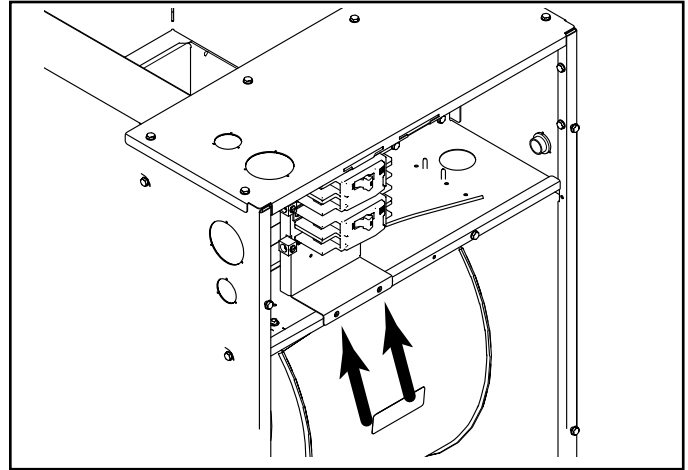

Figure 4

Note: For LUG models, do not remove knockouts or insulation.

15. Remove the appropriate breaker knock-out plates from Blower Access panel. Cut and remove insulation behind knock-out.
 - **IMPORTANT: Left knockout must be used for the following:**
 - ALL TEM8A0B24/30 air handlers
 - All 25 kW heaters
 - All TEM air handlers installed with a Single Power Entry Kit ship with a Heater Breaker Seal Kit. (See Seal Kit Installer's Guide for install instructions.)

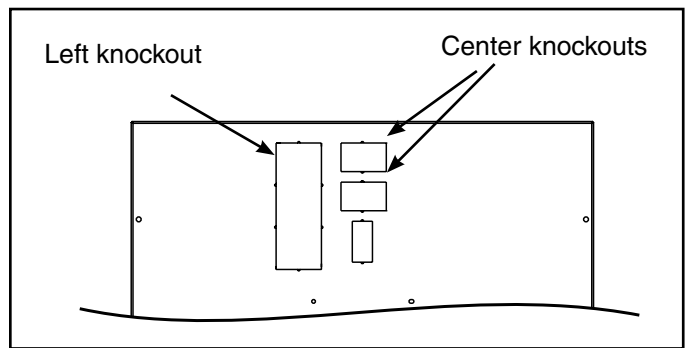

Figure 5

Note: Follow the instructions in the Breaker Seal Kit 18-GJ85D1-1 (latest rev). The Breaker Seal Kit will ship with the TEM8A0B air handlers, 25 KW heaters and single power entry kits for TEM air handlers.

- **Center knockouts:** Use for all other 4-20 kW heaters installations with all TEM air handler (except TEM8A0B24/30).
16. Install Blower Access panel ensuring alignment of breakers through access panel.
17. On the unit nameplate, check off the heater that has been installed or apply the new secondary nameplate label within the heater data table on the air handler nameplate as shown in Figure 6.

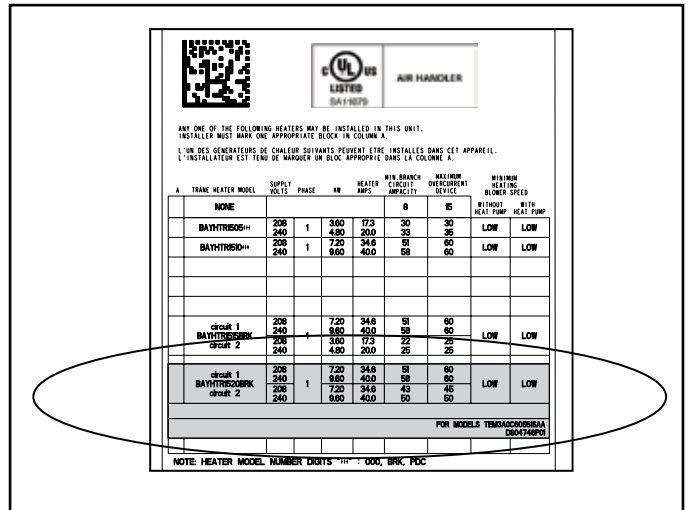

Figure 6 - New Label shown in place

Note: If using a heater in a TEM4 air handler, go to Step 18.

18. Cut insulated butt crimp terminal off of heater low voltage field wires (W1 - White, B/C - Blue)
19. Strip 1/2" insulation from the cut end for field thermostat wiring termination.
20. For the TEM8 models, set the heater size in the Configuration Menu.

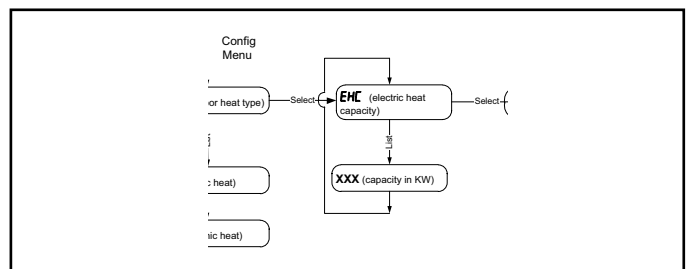

Figure 7 - Configuration Menu

INSTALLER'S GUIDE

HEATER TABLES

IMPORTANT: The BAYHTR15 electric heat accessory may include up to a combination of four 60 amp circuit breakers to provide an electrical disconnect for service personnel that is intended to help protect internal electrical components in the event of a short circuit or ground fault. As designed, the circuit breakers supplied in the BAYHTR15** accessory DO NOT provide over current protection of the branch circuit. Therefore, the branch circuit(s) shall be sized and protected according to the unit nameplate.**

BAYHTR -- HEATER DATA							
Heater Model No	No. of Circuits/Phases	240 Volt			208 Volt		
		Capacity		Heater Amps per Circuit	Capacity		Heater Amps per Circuit
		kW	BTUH		kW	BTUH	
BAYHTR1504BRKC, BAYHTR1504LUGB	1/1	3.84	13100	16.0	2.88	9800	13.8
BAYHTR1505BRKC, BAYHTR1505LUGB	1/1	4.8	16400	20.0	3.6	12300	17.3
BAYHTR1508BRKC, BAYHTR1508LUGB	1/1	7.68	26200	32.0	5.76	19700	27.7
BAYHTR1510BRKC, BAYHTR1510LUGB	1/1	9.6	32800	40.0	7.2	24600	34.6
BAYHTR1515BRKB, BAYHTR1516BRKB, BAYHTR1517BRKA	2/1	14.4	49200	40.0/20.0	10.8	36900	34.6/17.3
BAYHTR1519BRKB, BAYHTR1520BRKB, BAYHTR1521BRKB, BAYHTR1522BRKA, BAYHTR1523BRKA	2/1	19.2	65600	40.0/40.0	14.4	49200	34.6/34.6
BAYHTR1525BRKA	4/1	24.0	81900	25.0 each	18.0	61600	21.6 each
BAYHTR3510LUGC	1/3	9.6	32800	23.1	7.2	24600	20.0
BAYHTR3515LUGC, BAYHTR3517LUGA	1/3	14.4	49200	34.6	10.8	36900	30.0

Note: For model specific electrical data, see the air handler Installer's Guide or Submittal.

Note: Heaters with two circuits are displayed as Circuit 1/Circuit 2 (Minimum Circuit Ampacity for Circuit 1 includes Blower Motor Amp)

TEM4 MINIMUM HEATER AIRFLOW CFM - HEATER MATRIX							
Model No.	BAYHTR1504BRK* BAYHTR1504PDC* BAYHTR1504LUG* BAYHTR1505BRK* BAYHTR1505PDC* BAYHTR1505LUG*	BAYHTR1508BRK* BAYHTR1508PDC* BAYHTR1510BRK* BAYHTR1510PDC* BAYHTR1510LUG* BAYHTR3510LUG*	BAYHTR1515BRK* BAYHTR3515LUG*	BAYHTR1517BRK*	BAYHTR3517BRK*	BAYHTR1520BRK*	BAYHTR1521BRK*
TEM4A0B18S21S* TEM4A0B24S21S*	L / M	L / M	--	--	--	--	--
TEM4A0B30S31S* TEM4A0C36S31S*	L / L	L / L	--	L / M	L / H	--	--
TEM4A0C37S31S* TEM4A0C42S41S*	L / L	L / L	L / L	--	--	L / L	--
TEM4A0C48S41S*	L / L	L / L	L / L	--	--	--	L / L
TEM4A0C60S51S*	L / L	L / L	L / L	--	--	L / L	--

Cooling / HP Airflow

* = Followed by two digits

Note: On the TEM4A0C42S41S, TEM4A0C48S41S, and TEM4A0C60S51S models, taps 1-3 = Low, tap 4 = Med, tap 5 = High

TEM6 MINIMUM HEATER AIRFLOW CFM - HEATER MATRIX										
Model No.	BAYHTR1504BRK* BAYHTR1504LUG* BAYHTR1505BRK* BAYHTR1505LUG*	BAYHTR1508BRK* BAYHTR1508LUG*	BAYHTR1510BRK* BAYHTR1510LUG*	BAYHTR1516BRK*	BAYHTR1517BRK*	BAYHTR1522BRK*	BAYHTR1525BRK*	BAYHTR3510LUG*	BAYHTR3515LUG*	BAYHTR3517LUG*
TEM6A0B24H21S*	600 / 660	600 / 780	600 / 780	- / -	850 / 1050	- / -	- / -	600 / 780	- / -	850 / 900
TEM6A0B30H21S*	600 / 660	600 / 780	600 / 780	- / -	850 / 1050	- / -	- / -	600 / 780	- / -	850 / 900
TEM6A0C36H31S*	675 / 875	675 / 875	825 / 1225	1150 / 1325	- / -	1150 / 1325	- / -	675 / 875	1150 / 1250	- / -
TEM6A0C42H41S*	675 / 875	675 / 875	825 / 1225	1150 / 1325	- / -	1150 / 1325	- / -	675 / 875	1150 / 1250	- / -
TEM6A0C48H41S*	975 / 1200	975 / 1200	975 / 1200	975 / 1200	- / -	1125 / 1365	1350 / 1500	975 / 1200	975 / 1200	- / -
TEM6A0D48H41S*	975 / 1150	975 / 1150	975 / 1150	1125 / 1325	- / -	1125 / 1375	1125 / 1375	975 / 1150	1125 / 1375	- / -
TEM6A0C60H51S*	975 / 1200	975 / 1200	975 / 1200	975 / 1200	- / -	1125 / 1365	1350 / 1500	975 / 1200	975 / 1200	- / -
TEM6A0D60H51S*	975 / 1150	975 / 1150	975 / 1150	1125 / 1325	- / -	1125 / 1375	1125 / 1375	975 / 1150	1125 / 1375	- / -

TEM8 MINIMUM HEATER AIRFLOW CFM - HEATER MATRIX										
Model No.	BAYHTR1504BRK* BAYHTR1504LUG* BAYHTR1505BRK* BAYHTR1505LUG*	BAYHTR1508BRK* BAYHTR1508LUG*	BAYHTR1510BRK* BAYHTR1510LUG*	BAYHTR1516BRK*	BAYHTR1517BRK*	BAYHTR1522BRK*	BAYHTR1525BRK*	BAYHTR3510LUG*	BAYHTR3515LUG*	BAYHTR3517LUG*
TEM8A0B24V21D*	600 / 650	700 / 850	700 / 850	- / -	850 / 1000	- / -	- / -	700 / 850	- / -	850 / 1000
TEM8A0B30V21D*	600 / 650	700 / 850	700 / 850	- / -	850 / 1000	- / -	- / -	700 / 850	- / -	850 / 1000
TEM8A0C36V31D*	675 / 875	675 / 875	825 / 1225	1150 / 1325	- / -	1150 / 1325	- / -	675 / 875	1150 / 1250	- / -
TEM8A0C42V41D*	675 / 875	675 / 875	825 / 1225	1150 / 1325	- / -	1150 / 1325	- / -	675 / 875	1150 / 1250	- / -
TEM8A0C48V41D*	975 / 1200	975 / 1200	975 / 1200	975 / 1200	- / -	1125 / 1365	1350 / 1500	975 / 1200	975 / 1200	- / -
TEM8A0D48V41D*	975 / 1150	975 / 1150	975 / 1150	1125 / 1325	- / -	1125 / 1375	1125 / 1375	975 / 1150	1125 / 1375	- / -
TEM8A0C60V51D*	975 / 1200	975 / 1200	975 / 1200	975 / 1200	- / -	1125 / 1365	1350 / 1500	975 / 1200	975 / 1200	- / -
TEM8A0D60V51D*	975 / 1150	975 / 1150	975 / 1150	1125 / 1325	- / -	1125 / 1375	1125 / 1375	975 / 1150	1125 / 1375	- / -

Cooling / HP Airflow

* = Followed by two digits

HEATER STAGING

The TEM air handler families do not stage air flow in correlation with heater element staging. The minimum heating air flow table is representative for any call for indoor heat.

BAYHTR ELECTRIC HEAT STAGE MATRIX											
Model No.	BAYHTR1504BRK* BAYHTR1504LUG*	BAYHTR1505BRK* BAYHTR1505LUG*	BAYHTR1508BRK* BAYHTR1508LUG*	BAYHTR1510BRK* BAYHTR1510LUG*	BAYHTR1516BRK*	BAYHTR1517BRK*	BAYHTR1522BRK*	BAYHTR1525BRK*	BAYHTR3510LUG*	BAYHTR3515LUG*	BAYHTR3517LUG*
Electric Heat Stages	1	1	1	1	2	2	2	2	1	1	1
Stage 1 Capacity (kW)	3.84	4.8	7.68	9.6	9.6	9.6	9.6	12.0	9.6	14.4	14.4
Stage 2 Capacity (kW)	3.84	4.8	7.68	9.6	14.4	14.4	19.2	24.0	9.6	14.4	14.4

Since the manufacturer has a policy of continuous product and product data improvement, it reserves the right to change design and specification without notice.

18-HB22D1-12



Trane
6200 Troup Highway
Tyler, TX 75707-9010