

# ICE MAKER INSTALLATION INSTRUCTIONS

## INSTRUCTIONS D'INSTALLATION DE LA MACHINE À GLAÇONS

## INSTRUCCIONES DE INSTALACIÓN DE LA FÁBRICA DE HIELO

### TABLE OF CONTENTS/TABLE DES MATIÈRES/ÍNDICE

<b>ICE MAKER SAFETY</b> .....	1	<b>SÉCURITÉ DE LA MACHINE</b>		<b>SEGURIDAD DE LA FÁBRICA</b>	
<b>INSTALLATION INSTRUCTIONS</b> .....	2	<b>À GLAÇONS</b> .....	13	<b>DE HIELO</b> .....	25
Unpack the Ice Maker .....	2	<b>INSTRUCTIONS D'INSTALLATION</b> .....	14	<b>INSTRUCCIONES DE INSTALACIÓN</b> .....	26
Location Requirements .....	2	Déballage de la machine à glaçons.....	14	Cómo desempacar la máquina	
Electrical Requirements .....	3	Exigences d'emplacement.....	14	de hielo .....	26
Water Supply Requirements .....	4	Spécifications électriques.....	15	Requisitos de ubicación.....	26
Vacation or Extended Time Without Use..	4	Spécifications de l'alimentation en eau ..	16	Requisitos eléctricos.....	27
Connect Water Supply .....	4	Vacances ou longue		Requisitos del suministro de agua.....	28
Drain Pump Installation		période d'inutilisation .....	16	Vacaciones o tiempo prolongado	
(on some models).....	5	Raccordement à la canalisation d'eau ..	16	sin uso .....	28
Drain Connection .....	8	Installation de la pompe de vidange		Conexión del suministro de agua .....	28
Door Reversal—Side Swing Only .....	9	(sur certains modèles) .....	17	Instalación de la bomba de desagüe	
Leveling .....	11	Raccord au drain.....	20	(en algunos modelos) .....	29
Cleaning .....	11	Inversion du sens de la porte –		Conexión de desagüe .....	32
		porte à ouverture latérale uniquement... 21		Reversión de puertas—	
		Mise à niveau .....	23	Solo lado de apertura.....	33
		Nettoyage.....	23	Nivelación.....	35
				Limpieza .....	35

### ICE MAKER SAFETY

#### Your safety and the safety of others are very important.

We have provided many important safety messages in this manual and on your appliance. Always read and obey all safety messages.



This is the safety alert symbol.

This symbol alerts you to potential hazards that can kill or hurt you and others.

All safety messages will follow the safety alert symbol and either the word "DANGER" or "WARNING."

These words mean:

**⚠ DANGER**

You can be killed or seriously injured if you don't immediately follow instructions.

**⚠ WARNING**

You can be killed or seriously injured if you don't follow instructions.

All safety messages will tell you what the potential hazard is, tell you how to reduce the chance of injury, and tell you what can happen if the instructions are not followed.

## IMPORTANT SAFETY INSTRUCTIONS

**WARNING:** To reduce the risk of fire, electric shock, or injury when using your ice maker, follow these basic precautions:

- Plug into a grounded 3 prong outlet.
- Do not remove ground prong.
- Do not use an adapter.
- Do not use an extension cord.
- Connect to potable water supply only.
- Children should be supervised to ensure that they do not play with the appliance.
- Disconnect power before servicing.
- This appliance is not intended for use by persons (including children) with reduced physical, sensory, or mental capabilities, or lack of experience and knowledge, unless they have been given supervision or instruction concerning use of the appliance by a person responsible for their safety.
- Disconnect power before manually cleaning the inside components.
- Replace all parts and panels before operating.
- Use two or more people to move and install ice maker.

**SAVE THESE INSTRUCTIONS**

## INSTALLATION INSTRUCTIONS

### Unpack the Ice Maker

#### **⚠ WARNING**

##### **Excessive Weight Hazard**

**Use two or more people to move and install ice maker.**

**Failure to do so can result in back or other injury.**

### Removing Packaging Materials

Remove tape and glue from your ice maker before using.

- To remove any remaining tape or glue from the exterior of the ice maker, rub the area briskly with your thumb. Tape or glue residue can also be easily removed by rubbing a small amount of liquid dish soap over the adhesive with your fingers. Wipe with warm water and dry.
- Do not use sharp instruments, rubbing alcohol, flammable fluids, or abrasive cleaners to remove tape or glue. Do not use chlorine bleach on the stainless steel surfaces of the ice maker. These products can damage the surface of your ice maker.

### Cleaning Before Use

After you remove all of the packaging materials, clean the inside of your ice maker before using it. See the cleaning instructions in the "Ice Maker Care" section.

### Location Requirements

- To ensure proper ventilation for your ice maker, the front side must be completely unobstructed. The ice maker may be closed-in on the top and three sides, but the installation should allow the ice maker to be pulled forward for servicing if necessary.
- Installation of the ice maker requires a cold water supply inlet of 1/4" (6.35 mm) OD soft copper tubing with a shutoff valve or a Whirlpool supply line Part Number 8212547RB, and a Whirlpool approved drain pump, Part Number 1901A, only to carry the water to an existing drain.
- Choose a well-ventilated area with temperatures above 55°F (13°C) and below 110°F (43°C). Best results are obtained between 70°F and 90°F (21°C and 32°C).
- The ice maker must be installed in an area sheltered from the elements, such as wind, rain, water spray, or drip.
- When installing the ice maker under a counter, follow the recommended opening dimensions shown. Place electrical and plumbing fixtures in the recommended location as shown.

#### **NOTES:**

- Check that the power supply cord is not damaged or pinched or kinked between the ice maker and the cabinet.
- Check that the water supply line is not damaged or pinched or kinked between the ice maker and the cabinet.
- Check that the drain line (on some models) is not damaged or pinched or kinked between the ice maker and the cabinet.

- Check that the ice maker door is not flush with the standard cabinets to avoid problems with opening the ice maker door.

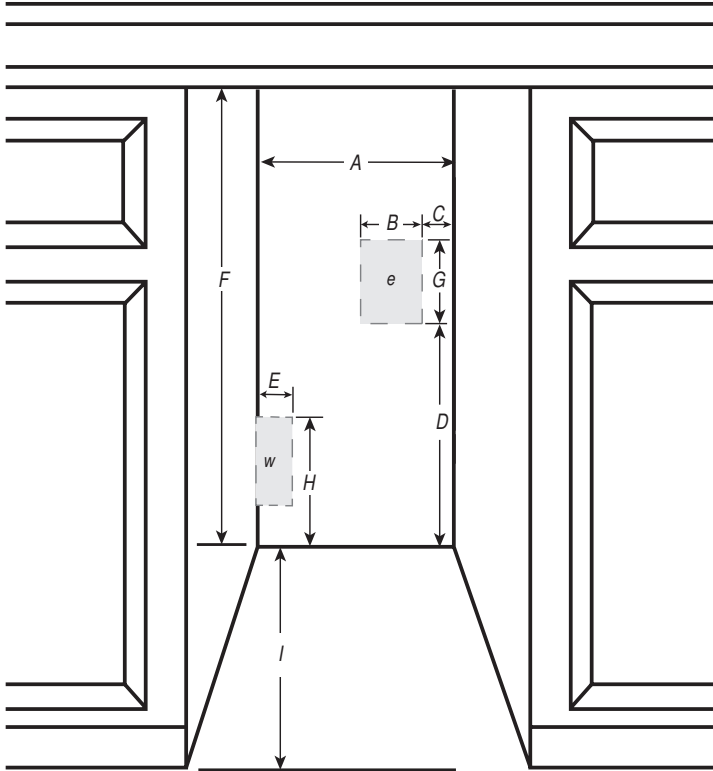

<b>A</b>	Width (For 15" Ice maker)	15" (38.1 cm) Min.
	Width (For 18" Ice maker)	18" (45.7 cm) Min.
<b>B</b>	Width of outlet location	6" (15 cm)
<b>C</b>	Outlet location – distance from side	1" (2.5 cm)
<b>D</b>	Outlet location – distance from bottom	12" (30.5 cm)
<b>E</b>	Width of water connection location	3½" (8.9 cm)
<b>F</b>	Height	34" (86.4 cm) Min. 34½" (87.6 cm) Max.
<b>G</b>	Height of outlet location	8" (20.3 cm)
<b>H</b>	Height of water connection location	9" (22.9 cm)
<b>I</b>	Depth of cabinet (min.)	24" (61.0 cm)
<b>e</b>	Recommended electrical connection location	
<b>w</b>	Recommended water connection location	

- Choose a location where the floor is even. It is important for the ice maker to be level in order to work properly. If needed, you can adjust the height of the ice maker by changing the height of the leveling legs. See "Leveling."

## Electrical Requirements

### ⚠ WARNING



#### Electrical Shock Hazard

**Plug into a grounded 3 prong outlet.**

**Do not remove ground prong.**

**Do not use an adapter.**

**Do not use an extension cord.**

**Failure to follow these instructions can result in death, fire, or electrical shock.**

Before you move your ice maker into its final location, it is important to make sure you have the proper electrical connection:

A 115 V, 60 Hz, AC only, 15 or 20 A electrical supply, properly grounded in accordance with the National Electrical Code and local codes and ordinances, is required.

It is recommended that a separate circuit, serving only your ice maker, be provided. Use a receptacle which cannot be turned off by a switch or pull chain.

**IMPORTANT:** If this product is connected to a GFCI (Ground Fault Circuit Interrupter) equipped outlet, nuisance tripping of the power supply may occur, resulting in loss of cooling. Ice quality may be affected. If nuisance tripping has occurred, and if the condition of the ice appears poor, dispose of it.

#### Recommended Grounding Method

The ice maker must be grounded. The ice maker is equipped with a power supply cord having a 3 prong grounding plug. The cord must be plugged into a mating, 3 prong, grounding-type wall receptacle, grounded in accordance with the National Electrical Code and local codes and ordinances. If a mating wall receptacle is not available, it is the personal responsibility of the customer to have a properly grounded, 3 prong wall receptacle installed by a qualified electrician.

## Water Supply Requirements

Check that the water supply lines are insulated against freezing conditions. Ice formations in the supply lines can increase water pressure and damage your ice maker or home. Damage from frozen supply lines is not covered by the warranty.

A cold water supply with water pressure of between 30 and 120 psi (207 and 827 kPa) is required to operate the ice maker. If you have questions about your water pressure, call a licensed, qualified plumber.

### Reverse Osmosis Water Supply

#### IMPORTANT:

- A reverse osmosis water filtration system is not recommended for ice makers that have a drain pump installed.
- For gravity drain systems only.
- The pressure of the water supply coming out of a reverse osmosis system going to the water inlet valve of the ice maker needs to be between 30 and 120 psi (207 and 827 kPa).

If a reverse osmosis water filtration system is connected to your cold water supply, the water pressure to the reverse osmosis system needs to be a minimum of 40 to 60 psi (276 to 414 kPa).

**NOTE:** The reverse osmosis system must provide 1 gal. (3.8 L) of water per hour to the ice maker for proper ice maker operation. If a reverse osmosis system is desired, only a whole-house capacity reverse osmosis system, capable of maintaining the steady water supply required by the ice maker, is recommended. Faucet capacity reverse osmosis systems are not able to maintain the steady water supply required by the ice maker.

If the water pressure to the reverse osmosis system is less than 40 to 60 psi (276 to 414 kPa):

- Check to see whether the sediment filter in the reverse osmosis system is blocked. Replace the filter if necessary.
- Allow the storage tank on the reverse osmosis system to refill after heavy usage.

If you have questions about your water pressure, call a licensed, qualified plumber.

## Vacation or Extended Time Without Use

- When you will not be using the ice maker for an extended period of time, turn off the water and power supply to the ice maker.
- Check that the water supply lines are insulated against freezing conditions. Ice formations in the supply lines can increase water pressure and cause damage to your ice maker or home. Damage from freezing is not covered by the warranty.

## Connect Water Supply

Read all directions before you begin.

#### IMPORTANT:

- Connect to potable water supply only.

Do not use with water that is microbiologically unsafe or of unknown quality without adequate disinfection before or after the system. Systems certified for cyst reduction may be used on disinfected waters that may contain filterable cysts.

- Plumbing shall be installed in accordance with the International Plumbing Code and any local codes and ordinances.
- Use copper tubing or Whirlpool supply line, Part Number 8212547RP, and check for leaks.
- Install tubing only in areas where temperatures will remain above freezing.

#### Tools Needed

Gather the required tools and parts before starting installation:

- Flat-blade screwdriver
- 7/16" and 1/2" open-end wrenches or two adjustable wrenches
- 1/4" nut driver

**NOTE:** Do not use a piercing-type or 3/16" (4.76 mm) saddle valve which reduces water flow and clogs more easily.

### Connecting the Water Line

1. Turn off main water supply. Turn on nearest faucet long enough to clear line of water.
2. Using a 1/2" copper supply line with a quarter-turn shutoff valve or the equivalent, connect the ice maker as shown.

**NOTE:** To allow sufficient water flow to the ice maker a minimum 1/2" diameter home supply line is recommended.

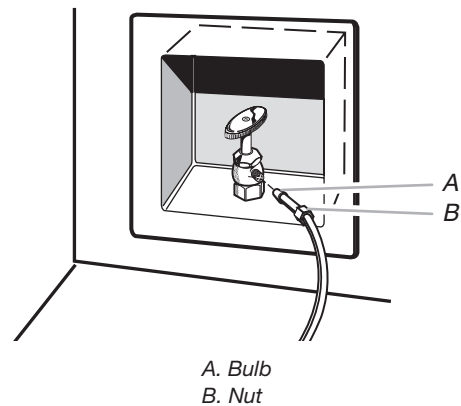

3. Now you are ready to connect the copper tubing. Use 1/4" (6.35 mm) O.D. soft copper tubing for the cold water supply.
  - Ensure that you have the proper length needed for the job. Be sure both ends of the copper tubing are cut square.

- Slip compression sleeve and compression nut on copper tubing as shown. Insert end of tubing into outlet end squarely as far as it will go. Screw compression nut onto outlet end with adjustable wrench. Do not overtighten.

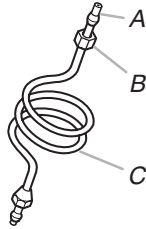

A. Compression sleeve  
B. Compression nut  
C. Copper tubing

4. Place the free end of the tubing into a container or sink, and turn on main water supply and flush out tubing until water is clear. Turn off shutoff valve on the water pipe.  
**IMPORTANT:** Always drain the water line before making the final connection to the inlet of the water valve to avoid possible water valve malfunction.
5. Bend the copper tubing to meet the water line inlet which is located on the back of the ice maker cabinet as shown. Leave a coil of copper tubing to allow the ice maker to be pulled out of the cabinet or away from the wall for service.

**Rear View**

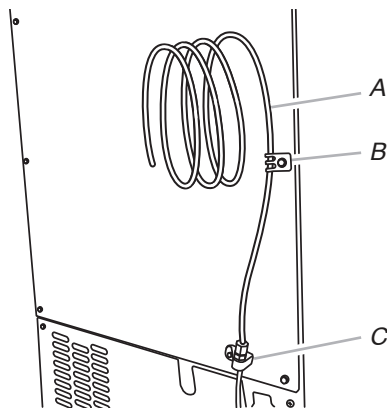

A. Copper tubing  
B. Water supply tube clamp  
C. Inlet water tube clamp and supply line connector

6. Remove and discard the short, black plastic tube from the end of the water line inlet.
7. Thread the nut onto the end of the tubing. Tighten the nut by hand. Then tighten it with a wrench two more turns. Do not overtighten.

**NOTE:** To avoid rattling, be sure the copper tubing does not touch the cabinet's side wall or other parts inside the cabinet.

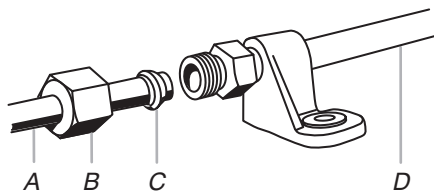

A. Line to ice maker  
B. Nut (purchased)  
C. Ferrule (purchased)  
D. Supplied line from ice maker

8. Install the water supply tube clamp around the water supply line to reduce strain on the coupling.
9. Turn shutoff valve ON.
10. Check for leaks. Tighten any connections (including connections at the valve) or nuts that leak.

## Drain Pump Installation (on some models)

**NOTES:**

- Connect drain pump to your drain in accordance with all state and local codes and ordinances.
- It may be desirable to insulate drain tube thoroughly up to drain inlet to minimize condensation on the drain tube. Insulated tube kit Part Number W10365792 is available for purchase.
- Drain pump is designed to pump water to a maximum height of 10 ft (3 m). Use only Whirlpool approved drain pump kit Part Number 1901A.
- Do not connect the outlet end of the drain tube to a closed pipe system to keep drain water from backing up into the ice maker.

**Kit Contains:**

- Drain pump kit Part Number 1901A
- 5/8" I.D. x 5 1/8" drain tube (ice maker bin to drain pump reservoir inlet)
- 1/2" I.D. x 10 ft (3 m) drain tube hose (drain pump discharge to household drain)
- 5/16" I.D. x 32" (81 cm) vent tube (drain pump reservoir vent to ice maker cabinet back)
- Cable tie (secures vent tube to black suction tube) (1)
- #8-32 x 3/8" pump mounting screws (secures drain pump to baseplate and clamps to back of ice maker) (5)
- 5/8" small adjustable hose clamp (secures vent to drain pump)
- 7/8" large adjustable hose clamp, (secures drain tube to ice maker bin and drain pump reservoir inlet) (3)
- Rear panel (2)
- Instruction sheet

### If Ice Maker Is Currently Installed

**NOTE:** If ice maker is not installed, please proceed to "Drain Pump Installation" section.

1. Push the selector switch to the OFF position.

## ⚠ WARNING



### Electrical Shock Hazard

**Disconnect power before servicing.**  
**Replace all parts and panels before operating.**  
**Failure to do so can result in death or electrical shock.**

- Unplug ice maker or disconnect power.
- Turn off water supply. Wait 5 to 10 minutes for the ice to fall into the storage bin. Remove all ice from bin.
- Unscrew the drain cap from the bottom of the water pan located inside the storage bin. Allow water to drain completely. Replace drain cap. See "Drain Cap" illustration.

### Drain Cap

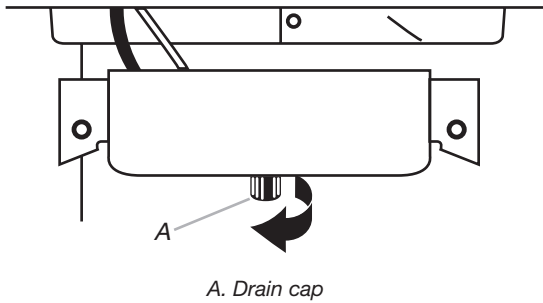

- If ice maker is built into cabinets, pull ice maker out of the opening.
- Disconnect water supply line. See "Water Supply Line" illustration.

### Water Supply Line

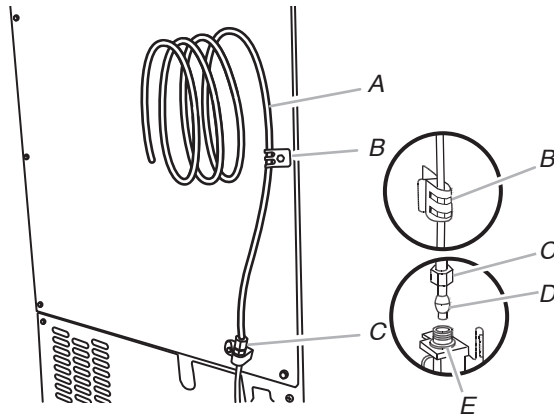

- A. 1/4" (6.35 mm) copper tubing
- B. Cable clamp
- C. 1/4" compression nut
- D. Ferrule (sleeve)
- E. Ice maker connection

### Drain Pump Installation

**NOTE:** Do not kink, smash or damage tubes or wires during installation.

- Unplug ice maker or disconnect power.
- Remove rear panel. See "Rear Panel" illustration for 5 screw locations. Pull rear panel away from the drain tube and discard.

### Rear Panel

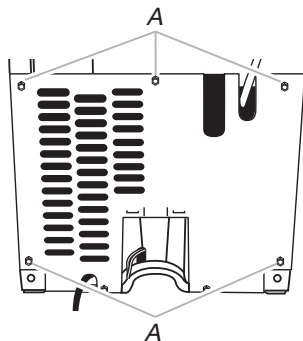

A. Screw locations

- Remove the old drain tube and clamp attached to the ice maker bin.
  - NOTE:** Discard old drain tube and clamp.
- Install new drain tube (5/8" I.D. x 5 1/8") from ice maker bin to drain pump reservoir inlet using new adjustable clamps. See "Drain Tube" illustration.

### NOTES:

- Do not kink.
- Trim tube length if required.

### Drain Tube

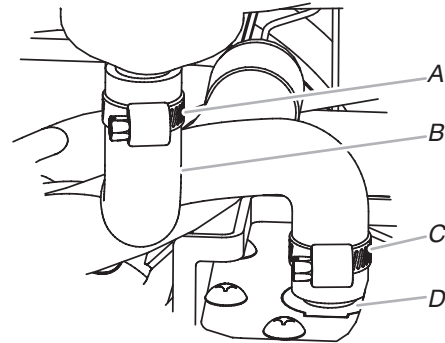

- A. 7/8" adjustable hose clamp
- B. Drain tube (ice bin to drain pump)
- C. 7/8" adjustable hose clamp
- D. Drain pump reservoir inlet

- Install vent tube (5/16" I.D. x 32" [81 cm]) to drain pump reservoir vent. Use one of the supplied 5/8" small adjustable clamp. See "Parts Locations" illustration.

**NOTE:** Do not install household drain tube at this time.

### Parts Locations

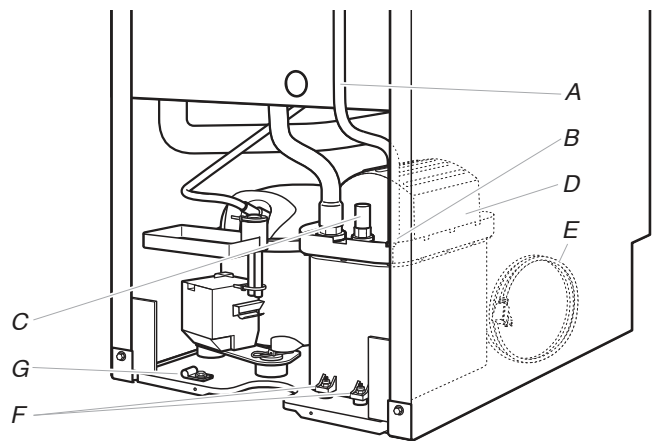

- A. Vent tube
- B. 5/8" hose clamp
- C. Drain pump discharge tube
- D. Drain pump
- E. Ice maker unit power cord
- F. #8-32 x 3/8" pump mounting screws
- G. Drain pump power cord, clamp and screw

- Remove power cord clamp and ground screw attached to ice maker power cord, which is mounted to the unit base. See "Parts Locations" illustration.

**NOTE:** Clamp and screw will be reused.



- Slide drain pump into the ice maker base on the right side. The pump mounting tab should slip into the rectangular slot in the ice maker base. It will be necessary to tip the pump slightly to slip into the slot. See "Drain Pump Mounting Tab Slot" illustration.

#### Drain Pump Mounting Tab Slot

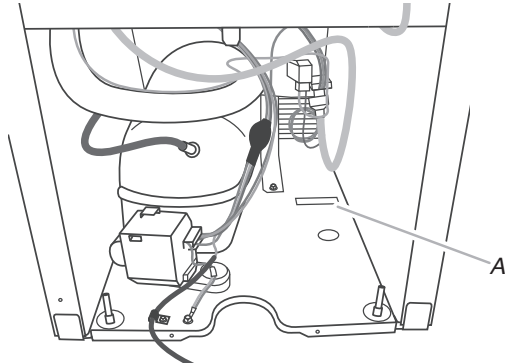

A. Mounting tab slot

#### Drain Pump Installed

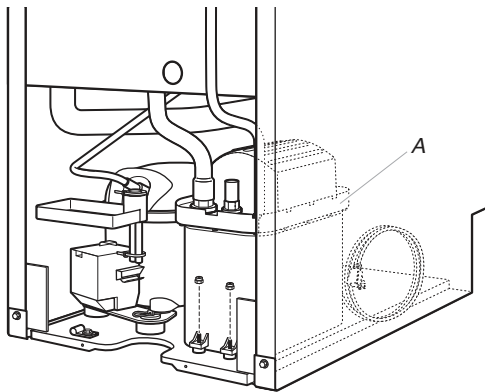

A. Drain pump installed

- Align the 2 screw holes at the rear of the pump. Use two #8-32 x 3/8" screws, supplied. See "Parts Locations" illustration.
- Connect drain tube to ice maker bin outlet (5/8" I.D.), using 7/8" adjustable clamp, supplied. See "Drain Tube" illustration.
- Coil ice maker power cord into a 4" (10.2 cm) diameter coil. Wrap electrical tape around the power cord in several places to keep the cord in a coil. Locate coiled power cord between the drain pump and side of enclosure and plug into the receptacle of the drain pump. See "Parts Locations" illustration.
- Attach the drain pump power cord to ice maker unit base with clamp and screw (removed in Step 6) that was used to attach ice maker power cord. See "Parts Locations" illustration.
- Place new rear panel (small one for 15" ice makers, large one for 18") against the back of the ice maker. Route the vent tube and drain pump discharge tube through cutouts in the rear panel.
- Secure rear panel with original screws. See "Rear Panel" illustration.
- Secure vent tube to back of ice maker using three clamps and three #8-32 x 3/8" screws, supplied. See "Vent Tube" illustration.

#### Vent Tube

**NOTE:** Do not pinch, kink or damage the vent tube. Check that it is not damaged or pinched or kinked between the cabinet and the ice maker.

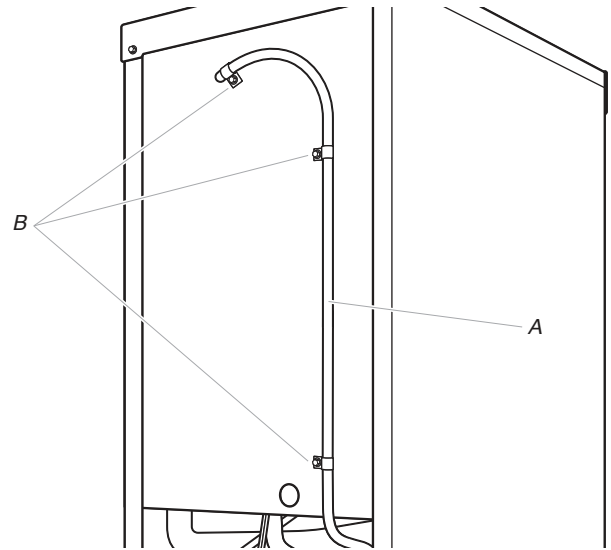

A. Vent tube  
B. Clamps and screws

- Attach 1/2" I.D. x 10 ft (3 m) drain tube to pump discharge tube. See "Parts Locations" illustration.
 

**NOTE:** Do not connect outlet end of drain tube to a closed pipe system to keep drain water from backing up into the ice maker.
- Connect ice maker to water supply and install ice maker as specified by the product installation instructions.
- Check all connections for leaks.

## ⚠ WARNING



### Electrical Shock Hazard

**Plug into a grounded 3 prong outlet.**

**Do not remove ground prong.**

**Do not use an adapter.**

**Do not use an extension cord.**

**Failure to follow these instructions can result in death, fire, or electrical shock.**

- Plug in ice maker or reconnect power.
- Turn on ice maker.
- Wait for rinsing cycle, approximately 5 minutes, to be sure the ice maker is operating properly.

## Drain Connection

### Gravity Drain System

Connect the ice maker drain to your drain in accordance with all state and local codes and ordinances. If the ice maker is provided with a gravity drain system, follow these guidelines when installing drain lines. This will help keep water from flowing back into the ice maker storage bin and potentially flowing onto the floor, causing water damage.

- Drain lines must have a minimum of 5/8" (15.88 mm) I.D. (inside diameter).
- Drain lines must have a 1" drop per 48" (2.54 cm drop per 122 cm) of run or 1/4" drop per 12" (6.35 mm per 30.48 cm) of run and must not have low points where water can settle.
- The floor drains must be large enough to accommodate drainage from all drains.
- The ideal installation has a standpipe with a 1½" (3.81 cm) to 2" (5.08 cm) PVC drain reducer installed directly below the outlet of the drain tube as shown. You must maintain a 1" (2.54 cm) air gap between the drain hose and the standpipe.
- Do not connect the outlet end of the drain tube to a closed pipe system to keep drain water from backing up into the ice maker.

**IMPORTANT:** A drain pump is necessary when a floor drain is not available. A Drain Pump kit, Part Number 1901A, is available for purchase.

#### Side View

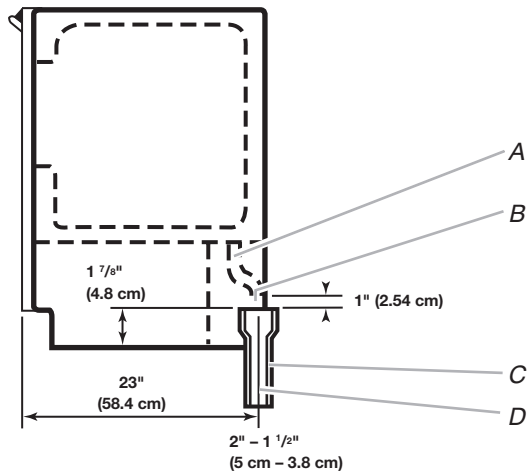

- A. Drain hose  
 B. 1" (2.54 cm) air gap  
 C. PVC drain reducer  
 D. Center of drain should be 23" (58.4 cm) from front of door, with or without the 3/4" (1.91 cm) panel on the door. The drain should also be centered from left to right (7<sup>5</sup>/<sub>16</sub>" [18.56 cm] from either side of the ice maker).

### Drain Pump System (on some models)

#### IMPORTANT:

- Connect the ice maker drain to your drain in accordance with the International Plumbing Code and any local codes and ordinances.
- The drain pump discharge line must terminate at an open sited drain.
  - Maximum rise 10 ft (3.1 m)
  - Maximum run 100 ft (30.5 m)

#### NOTES:

- If the drain hose becomes twisted and water cannot drain, your ice maker will not work.

- It may be desirable to insulate the drain line thoroughly up to the drain inlet. An Insulation Sleeve kit, Part Number W10365792, is available for purchase.
- Do not connect the outlet end of the drain tube to a closed pipe system to keep drain water from backing up into the ice maker.
- Drain pump maximum capability: For every 1 ft (0.31 m) of rise, subtract 10 ft (3.1 m) of maximum allowable run.

### Connecting the Drain

After ensuring that the drain system is adequate, follow these steps to properly place the ice maker:

## ⚠ WARNING



### Electrical Shock Hazard

**Plug into a grounded 3 prong outlet.**

**Do not remove ground prong.**

**Do not use an adapter.**

**Do not use an extension cord.**

**Failure to follow these instructions can result in death, fire, or electrical shock.**

1. Plug into a grounded 3 prong outlet.

## ⚠ WARNING

### Excessive Weight Hazard

**Use two or more people to move and install ice maker.**

**Failure to do so can result in back or other injury.**

2. **Style 1**— For gravity drain system, push the ice maker into position so that the ice maker drain tube is positioned over the PVC drain reducer. See "Gravity Drain System."
- Style 2**— For drain pump system connect the drain pump outlet hose to the drain. See "Drain Pump System."
3. Recheck the ice maker to be sure that it is level. See "Leveling."
4. If it is required by your local sanitation code, seal the cabinet to the floor with an approved caulking compound after all water and electrical connections have been made.



## Door Reversal—Side Swing Only

### Tools Needed

Gather the required tools and parts before starting installation.

- 5/16" wrench
- Flat putty knife
- 1/4" wrench
- Phillips screwdriver

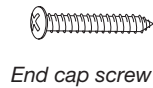
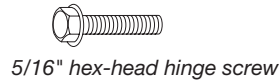
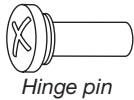

### Remove Stainless Steel Door Wrap Panel (on some models)

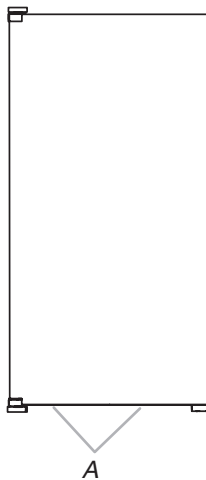

A. Hex-head screws

1. Remove the two hex-head screws located under the stainless steel door wrap panel flange on the bottom of the door.
2. Pull up and outward on the door wrap panel from the bottom.
3. Rotate the door wrap panel until it separates from the door and pull up.

**NOTE:** Be sure the edge guards do not separate from the door wrap panel.

## Door Stop and End-Cap Reversal

### ⚠ WARNING



#### Electrical Shock Hazard

**Disconnect power before servicing.**

**Replace all parts and panels before operating.**

**Failure to do so can result in death or electrical shock.**

1. Unplug the ice maker or disconnect power.
2. Remove the handle screws and handle (on some models).
3. Remove the hinge pin from the top hinge.
4. Remove the door from the hinges and replace the top hinge pin.
5. Remove the screw and door stop at corner A. Remove the screw and end cap at corner C. Place the door stop at corner C, and tighten screw. Place the end cap at corner A, and tighten screw.
6. Remove the screw and door stop at corner D. Remove the screw and end cap at corner B. Place the door stop at corner B, and tighten screw. Place the end cap at corner D, and tighten screw.

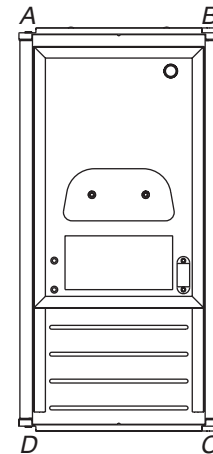

- A. Top corner open (no end cap)      C. Beginning bottom corner end cap  
 B. Beginning top corner end cap      D. Bottom corner open (no end cap)

7. Depending on your model, the brand badge for the front door of your ice maker may be in the package with the Use and Care Guide. Fasten the brand badge to the door.
8. Set the door aside.

---

## Reverse Hinges

---

1. Unscrew and remove the top hinge. Replace the screws in the empty hinge holes.
  2. Remove the screws from the bottom of the opposite side of the ice maker cabinet. Turn the top hinge upside down so that the hinge pin points up. Place the hinge on the bottom opposite side of the ice maker and tighten screws.
  3. Remove the "old" bottom hinge screws and hinge. Replace the screws in the empty hinge holes.
  4. Remove the screws from the top of the opposite side of the ice maker cabinet. Turn the hinge upside down so that the hinge pin points down. Place the hinge on the top opposite side of the ice maker and tighten the screws.
  5. Remove the top hinge pin.
- 

## Replace Door

---

1. Place the door on the bottom hinge pin.
  2. Align the door with the top hinge hole and replace the top hinge pin.
  3. Replace the handle and handle screws.
- 

## Replace Door Wrap (on some models)

---

1. Place the door wrap flange onto the door top and ensure that it fits correctly.
2. Rotate the door wrap downward until it covers the door surface completely.
3. Install the two hex-head screws into the bottom of the door.

### Top Hinge

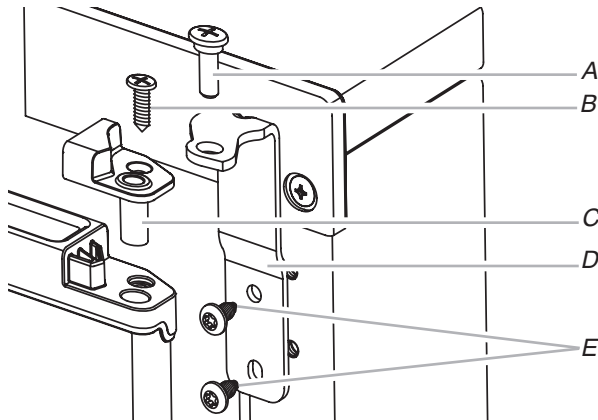

- A. Hinge pin  
B. Phillips-head countersink screw  
C. Hinge pin sleeve  
D. Hinge  
E. Hex-head hinge screw

### Bottom Hinge

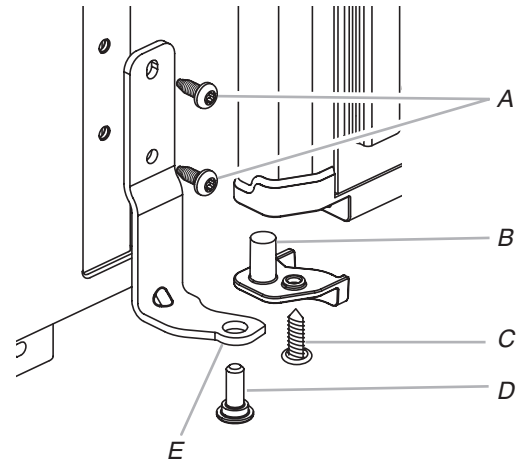

- A. Hex-head hinge screw  
B. Hinge pin sleeve  
C. Phillips-head countersink screw  
D. Hinge pin  
E. Hinge
- 

## Reverse Door Catch

---

1. Remove the white decorative screws from the opposite side of the door and set aside.
2. Remove the screws from the magnetic door catch and place them on the opposite side of the door.

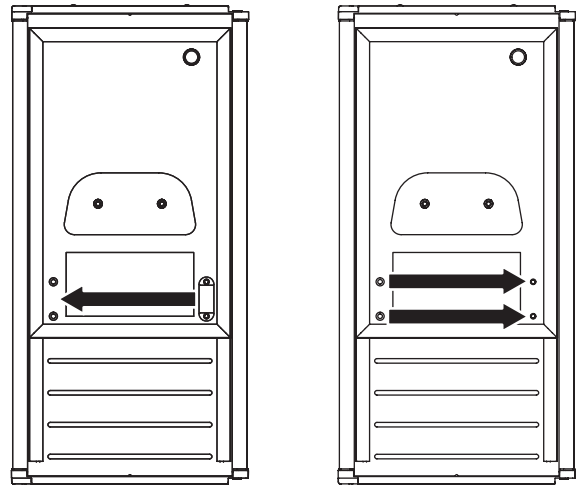

3. Install the white decorative screws on the opposite side of the door.

**⚠ WARNING**



**Electrical Shock Hazard**

**Plug into a grounded 3 prong outlet.**

**Do not remove ground prong.**

**Do not use an adapter.**

**Do not use an extension cord.**

**Failure to follow these instructions can result in death, fire, or electrical shock.**

4. Plug into a grounded 3 prong outlet.

## Leveling

It is important for the ice maker to be level in order to work properly. Depending upon where you install the ice maker, you may need to make several adjustments to level it. You may also use the leveling legs to lower the height of the ice maker for undercounter installations.

### Tools Needed

Gather the required tools and parts before starting installation.

- Level
- Adjustable wrench

**NOTE:** It is easier to adjust the leveling legs if you have another person to assist you.

1. Move the ice maker to its final location.
 

**NOTE:** If this is a built-in installation, move the ice maker as close as possible to the final location.
2. Place the level on top of the product to see whether the ice maker is level from front to back and side to side.
3. Push up on the top front of the ice maker, and then locate the leveling screws that are on the bottom front of the ice maker.
4. Using an adjustable wrench, change the height of the legs as follows:
  - Turn the leveling leg to the right to lower that side of the ice maker.
  - Turn the leveling leg to the left to raise that side of the ice maker.

**NOTE:** The ice maker should not wobble. Use shims to add stability when needed.

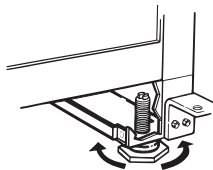

5. Push up on the top rear of the ice maker and locate the leveling legs that are on the bottom rear of the ice maker.
6. Follow the instructions in Step 4 to change the height of the legs.

7. Use the level to recheck the ice maker to see that it is even from front to back and side to side. If the ice maker is not level, repeat steps 2 to 5. If the ice maker is level, go to the "Connect Water Supply" section.

## Cleaning

### Interior Components

1. Unplug ice maker or disconnect power.
2. Open the storage bin door and remove any ice that is in the bin.
3. Remove the drain cap from the water pan and drain thoroughly. Replace the drain cap securely on the water pan. If the drain cap is loose, water will empty from the water pan, and you will have either thin ice or no ice.
4. Pull out on the bottom of the cutter grid cover until the snaps release to remove.
 

**NOTE:** On some models, remove the screw from the cutter grid cover.
5. Unplug the wiring harness from the left side of the cutter grid.

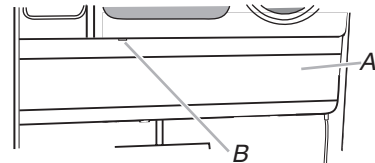

A. Cutter grid cover  
B. Screw (on some models)

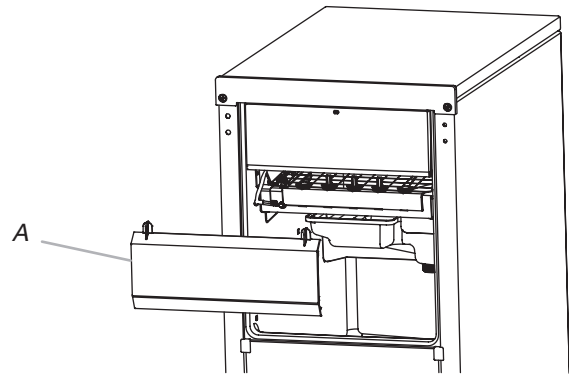

A. Cutter grid cover

6. Unplug the ice level sensor from the right side of the cutter grid. Pull the ice level sensor down and forward away from the cutter grid.

- Remove the right-hand and left-hand screws. Lift the cutter grid up and out.

**NOTE:** Make sure the plastic spacer from the right-hand side of the cutter grid bracket stays with the cutter grid.

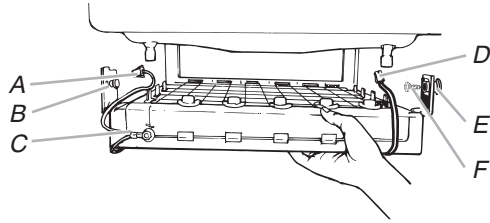

- |                        |                             |
|------------------------|-----------------------------|
| A. Cutter grid harness | D. Ice level sensor harness |
| B. Screw               | E. Plastic spacer           |
| C. Cutter grid         | F. Screw                    |

- Remove the mounting screw that holds the water pan in place. Pull out on the front of the water pan.
- Disconnect the pump bracket from the water pan and unplug the water pan drain pump.

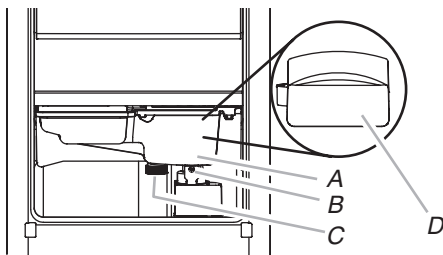

- |                    |                     |
|--------------------|---------------------|
| A. Water pan       | C. Drain cap        |
| B. Water pan screw | D. Drain pump cover |

- Remove, clean and replace the ice scoop holder and ice scoop.

**NOTE:** On some models, the ice scoop holder is located in the upper left of the unit, and on other models, the ice scoop holder is located in the lower left of the unit.

#### On Some Models

- Remove the holder by removing the 2 screws.
- Wash the ice scoop holder and ice scoop along with the other interior components using the following instructions.
- Replace the ice scoop holder by replacing the screws.

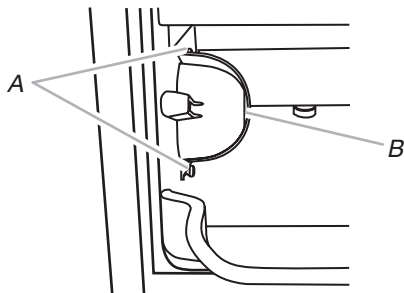

- |                     |
|---------------------|
| A. Screw            |
| B. Ice scoop holder |

#### On Some Models

- After removing the ice scoop, remove the holder by removing the 2 screws.

**NOTE:** On some models, remove the holder by lifting up on the ice scoop holder and then out.

- Wash the ice scoop holder along with the other interior components using the following instructions.
- Replace the ice scoop holder by replacing the screws or on some models, pushing in on the holder and then down.

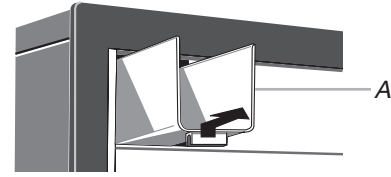

A. Ice scoop holder

- Wash the interior components (cutter grid, exterior of hoses, and water pan) and the storage bin, door gasket, ice scoop, and ice scoop holder with mild soap or detergent and warm water. Rinse in clean water. Then clean the same parts with a solution of 1 tbs (15 mL) of household bleach in 1 gal. (3.8 L) warm water. Rinse again thoroughly in clean water.
 

**NOTE:** Do not remove hoses. Do not wash plastic parts in dishwasher. They cannot withstand temperatures above 145°F (63°C).
- To replace the water pan, set the water pan inside the ice bin. Hook up the water pan pump. Snap the pump bracket back onto the water pan and place back into position. Secure the water pan by replacing the mounting screw.
- Check the following:
  - Drain cap from the water pan is securely in place. If the drain cap is loose, water will empty from the water pan, and you will have either thin ice or no ice.
  - Hose from water pan is inserted into storage bin drain opening.
- Slide the cutter grid back into place and secure it by replacing the right-hand screw and plastic spacer. Then tighten the left-hand screw. Reconnect the cutter grid harness and the ice level sensor harness.
- Replace the cutter grid cover.
 

**NOTE:** On some models, replace the cutter grid cover using the screw removed earlier.
- Gently wipe the control panel with a soft, clean dishcloth using warm water and a mild liquid dish detergent.
- Plug in ice maker or reconnect power.
- After cleaning, make sure that all controls are set properly and that no control indicators are flashing.