

Swivel Attachment Fig. AF771

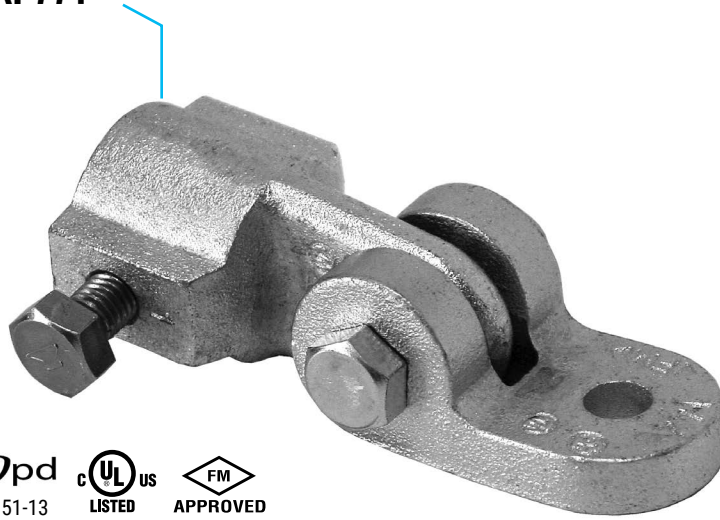

Material Specifications

Size Range:

Brace Member: See Table

Anchor Size: ½" - ¾" (M12 - M18)

Material

Carbon Steel

Finish

Plain

Electro-Galvanized per ASTM B633

Service

A seismic swivel attachment designed to connect a brace member to the building structure or to a seismic structural attachment. The AF771 rigidly braces piping systems subjected to horizontal and vertical seismic loads.

Approvals

cULus Listed (ANSI/UL 203a), FM Approved (FM 1950-13), & OSHPD (OPM-0351-13).

Complies with NFPA 13, ASCE 7, IBC, & MSS SP-127 bracing requirements.

Features

- The set screw provides a visual indication that proper installation has been achieved
- Eliminates brace member eccentricity by concentrically loading brace pipes

Ordering

Specify figure number, brace size, fastener size, finish, and description.

Disclaimer:

ASC Engineered Solutions does not provide any warranties and specifically disclaims any liability whatsoever with respect to ASC bracing products and components that are used in combination with products, parts or systems not manufactured or sold by ASC. In no event shall ASC be liable for any incidental, direct, consequential, special or indirect damages or lost profits where non-ASC bracing components have been, or are used.

Seis Brace® Seismic Fire Protection Design Tool may be accessed at www.seisbrace.com

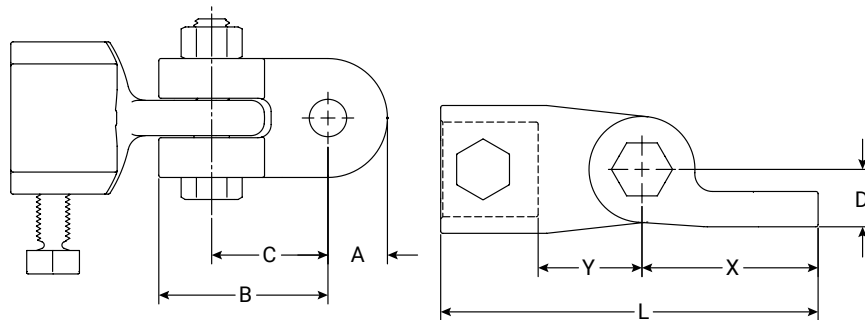

FIG. AF771 Dimensions and Weight

Brace Size	Anchor Size	A	B	C	D	L	X	Y	Weight
		in./mm	in./mm	in./mm	in./mm	in./mm	in./mm	in./mm	
1" DN25	½" - ¾" (M12-M18)	0.840	1.650	1.650	0.810	5.34	2.49	1.47	1.95
1½" DN32		21.34	41.91	41.91	20.57	135.6	63.2	37.3	0.88
									2.28
									1.03

Notes:

ASC Engineered Solutions™ brand bracing components are designed to be compatible ONLY with other ASC Engineered Solutions brand bracing components, resulting in a Listed seismic bracing assembly. Updated UL listing information may be viewed at www.ul.com and updated FM approval information may be viewed at www.approvalguide.com.



PROJECT INFORMATION	APPROVAL STAMP
Project:	Approved
Address:	Approved as noted
Contractor:	Not approved
Engineer:	Remarks:
Submittal Date:	
Notes 1:	
Notes 2:	

Swivel Attachment Fig. AF771

FIG. AF771 cULus Listing per ANSI/UL 203a (ASD)

Brace Member	Fastener Size	Horizontal Load Rating at Brace Angle			
		30°-44°	45°-59°	60°-90°	Listed
1"-1¼" Sch 40 Pipe DN25-DN32	½"-¾" (M12-M18)	1000 lbf (4.45 kN)	1414 lbf (6.29 kN)	1731 lbf (7.70 kN)	2000 lbf (8.90 kN)

- 1) Load ratings may apply to NPFA 13 fastener orientations A, B, C, D, E, F, G, H, or I.
- 2) Brace Angles are determined from Vertical.
- 3) Listed load ratings reduced for angle ranges in accordance with NFPA 13-2019 Table 18.5.2.3.
- 4) See table below for listed brace members.
- 5) Minimum safety factor of 2.2 in accordance with NFPA 13-2019 Section A.18.5.2.3.

FIG. AF771 cULus Listing per UL 203a (ASD) for NFPA 13-2016 Editions or Earlier

Brace Member	Fastener Size	Horizontal Load Rating at Brace Angle			
		30°-44°	45°-59°	60°-90°	Listed
1"-1¼" Sch 40 Pipe DN25-DN32	½"-¾" (M12-M18)	1870 lbf (8.32 kN)	2644 lbf (11.77 kN)	3238 lbf (14.40 kN)	3740 lbf (16.64 kN)

- 1) Load ratings may apply to NPFA 13 fastener orientations A, B, C, D, E, F, G, H, or I.
- 2) Brace Angles are determined from Vertical.
- 3) Listed load ratings reduced for angle ranges in accordance with NFPA 13-2016 Table 9.3.5.2.3.
- 4) See table below for listed brace members.
- 5) Minimum safety factor of 1.5 in accordance with NFPA 13-2016 Section A.9.3.5.2.3.

FIG. AF771 FM Approved (Listing) per FM 1950-13 (ASD)

Brace Member	Fastener Size	Horizontal Load Rating at Brace Angle			
		30°-44°	45°-59°	60°-74°	75°-90°
1"-1¼" Sch 40 Pipe DN25-DN32	½" (M12)	1820 lbf (8.10 kN)	2540 lbf (11.30 kN)	3110 lbf (13.83 kN)	3470 lbf (15.44 kN)
	⅝"-¾" (M16-M18)	1520 lbf (6.76 kN)	2150 lbf (9.56 kN)	2630 lbf (11.70 kN)	2930 lbf (13.03 kN)

- 1) Load ratings may apply to NPFA 13 fastener orientations A, B, C, D, E, F, G, H, or I.
- 2) Brace Angles are determined from Vertical.
- 3) Listed load ratings reduced for angle ranges in accordance with NFPA 13-2019 Table 18.5.2.3.
- 4) See table below for listed brace members.
- 5) Minimum safety factor of 1.5 in accordance with NFPA 13-2016 Section A.9.3.5.2.3. To convert the load ratings above to a safety factor of 2.2 per NFPA 13-2019 Section A.18.5.2.3, multiply load ratings by a factor of 0.68.
- 6) To convert to LRFD Load Ratings, ASD Load Ratings may be multiplied by a factor of 1.5.

FIG. AF771 Listed, Approved, & Tested Brace Members

Brace Member	Sizes	Standards (or Equivalent)	UL Listed	FM Approved
Sch. 40 NPS Pipe	1", 1¼"	ASTM A53, A106, A135, or A795	✓	✓
Sch. 40 Metric Pipe	DN25, DN32	KS D 3562	✓	✓

FIG. AF771 Horizontal Prying Factors (Pr) Per NFPA 13

Fastener Orientation	A	B	C	D	E	F	G	H	I
Brace Angle	30°-44°	45°-59°	60°-90°	30°-44°	45°-59°	60°-90°	30°-44°	45°-59°	60°-90°
AF771	4.17	2.00	0.96	1.97	2.38	2.96	1.93	1.36	1.11
AF771 w/ Metal Deck	4.17	2.00	0.96	-	-	-	-	-	-

Prying Factors calculated in accordance with NFPA 13-2019 Section A.18.5.12.2..

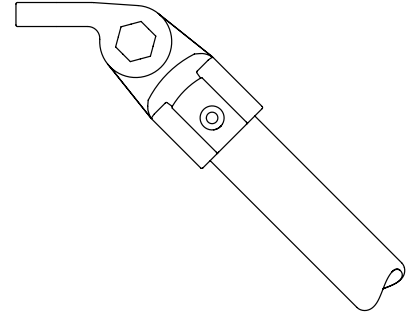

NFPA 13 Orientations A, B, or C

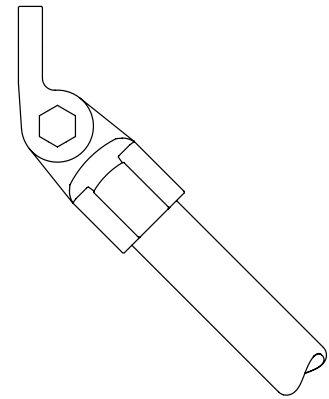

NFPA 13 Orientations D, E, or F

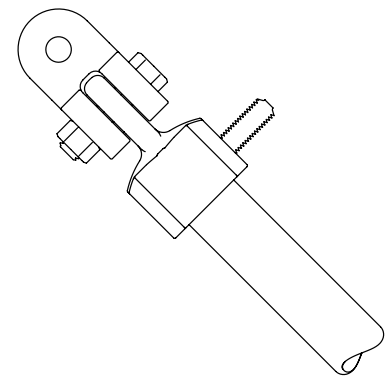

NFPA 13 Orientations G, H, or I



asc-es.com

Building connections that last™

Swivel Attachment Fig. AF771

Method 1 – Connection to Brace Member First

- 1 Slide the brace member into the socket until it contacts the back wall.
- 2 Hand tighten the set screw until it contacts the brace member. Continue to torque the set screw until the head breaks off.
- 3 Rotate the brace assembly up to the fastener or the related seismic structural attachment and connect through the mounting hole.
- 4 Tighten per the fastener or structural attachment specifications.
- 5 Ensure the brace angle is within the specified range.

Notes: The cross bolt should be hand tight. For visual inspection, at least one thread should be exposed.

Method 2 – Connection to Structure First

- 1 Connect the AF771 to the fastener or the related seismic structural attachment.
- 2 Tighten per the fastener or structural attachment specifications.
- 3 Slide the brace member into the socket until it contacts the back wall.
- 4 Hand tighten the set screw until it contacts the brace member. Continue to torque the set screw until the head breaks off.
- 5 Rotate the brace member until the brace angle is within the specified range.

Notes: The cross bolt should be hand tight. For visual inspection, at least one thread should be exposed.

Structural Attachments, Anchors, & Fasteners Listed, Approved, & Tested with the AF771

Structural Attachment	Structure
AF085	Steel Joist (Top Chord)
AF086	Horizontal Steel Flange (I-Beam Bottom Flange)
AF772	Horizontal Steel Flange (I-Beam Top or Bottom Flange)
AF778	Horizontal Steel Flange (I-Beam Top or Bottom Flange) C-Channel (Top or Bottom Flange) Vertical Flange of a Joist (Top Chord)
AF779	All Structures with the Applicable Approved Anchor or Fastener
DeWalt Power-Stud®+ SD1	Cracked Concrete Cracked Concrete Filled Metal Deck
DeWalt Power-Stud®+ SD2	Cracked Concrete Cracked Concrete Filled Metal Deck
DeWalt Wood-Knocker®II+	Cracked Concrete
DeWalt Bang-It®+	Cracked Concrete Filled Metal Deck
DeWalt DDI+™	Cracked Concrete Filled Metal Deck
Anchors & Fasteners Per NFPA 13	Cracked Concrete Cracked Concrete Filled Metal Deck Steel Wood Saw Lumber or Glue-Laminated Timbers



asc-es.com

Building connections that last™