

Universal Structural Brace Attachment Fig. AF778

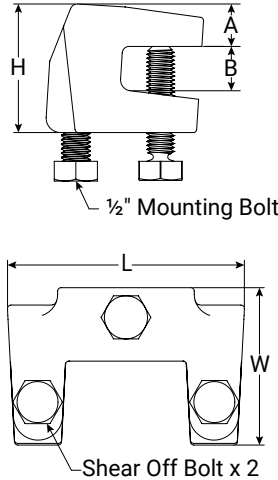
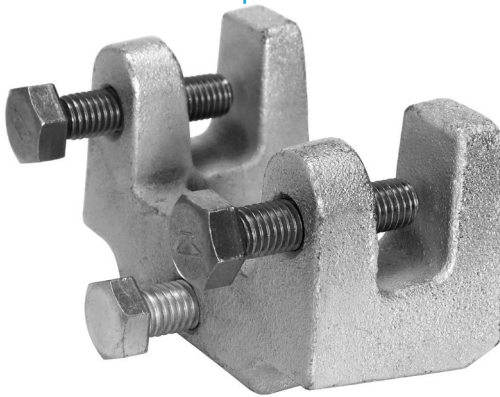

FIG. AF778 Dimensions and Weight

Mounting Bolt	A	B	L	W	H	Weight
	In./mm	In./mm	In./mm	In./mm	In./mm	lbs./kg
1/2"	0.75	0.75	4.13	2.75	2.25	2.26
(M12)	19.1	19.1	104.8	69.9	57.2	1.03

Notes:

ASC Engineered Solutions™ brand bracing components are designed to be compatible ONLY with other ASC Engineered Solutions brand bracing components, resulting in a Listed seismic bracing assembly. Updated UL listing information may be viewed at www.ul.com and updated FM approval information may be viewed at www.approvalguide.com.

Disclaimer:

ASC Engineered Solutions does not provide any warranties and specifically disclaims any liability whatsoever with respect to ASC bracing products and components that are used in combination with products, parts or systems not manufactured or sold by ASC. In no event shall ASC be liable for any incidental, direct, consequential, special or indirect damages or lost profits where non-ASC bracing components have been, or are used.

Seis Brace® Seismic Fire Protection Design Tool may be accessed at www.seisbrace.com

Installation

- 1 Place the AF778 on a horizontal or vertical steel flange
- 2 Hand tighten the set screws until they contact the flange. Continue to torque the set screws until the heads break off.
- 3 Mount the AF700, AF771, or AF076 to the 1/2" mounting bolt. The mounting bolt shall be installed wrench tight (typically finger tight plus 1/4 to 1/2 turns).

Notes: When installed with the AF700, AF771, or AF076, the lowest load rating at angle shall control the load rating of the assembly.

Material Specifications

Size Range:

Flange Thickness: 1/8" to 3/4" thick

Material

Ductile Iron Casting with Carbon Steel Hardware

Finish

Plain

Electro-Galvanized per ASTM B633

Service

A seismic structural attachment designed to attach to steel I-beams, flanges, and joists. The AF778 rigidly braces piping systems subjected to horizontal and vertical seismic loads.

Approvals

cULus Listed (ANSI/UL 203a), FM Approved (FM 1950-13), & OSHPD (OPM-0351-13). Complies with NFPA 13, ASCE 7, IBC, & MSS SP-127 bracing requirements.

Features

- The set screw provides a visual indication that proper installation has been achieved
- May be installed anywhere a Fig 92 standard throat beam clamp may be installed

Ordering

Specify figure number, finish, and description.



PROJECT INFORMATION	APPROVAL STAMP
Project:	Approved
Address:	Approved as noted
Contractor:	Not approved
Engineer:	Remarks:
Submittal Date:	
Notes 1:	
Notes 2:	

Universal Structural Brace Attachment Fig. AF778

FIG. AF778 cULus Listing per ANSI/UL 203a (ASD)

Structure	Load Orientation	Flange Thickness	Horizontal Load Rating at Brace Angle			
			30°-44°	45°-59°	60°-90°	Listed
Horizontal Steel Flange and Vertical Steel Flange	Parallel to Flange Perpendicular to Flange	0.1875 – 0.750 in (4.76 – 19.05 mm)	800 lbf (3.56 kN)	1131 lbf (5.03 kN)	1385 lbf (6.16 kN)	1600 lbf (7.12 kN)

- 1) Listed for installation with Fig. AF700, AF771, and AF076
- 2) Brace Angles are determined from Vertical.
- 3) Listed load ratings reduced for angle ranges in accordance with NFPA 13-2019 Table 18.5.2.3.
- 4) Minimum safety factor of 2.2 in accordance with NFPA 13-2019 Section A.18.5.2.3.

FIG. AF778 cULus Listing per UL 203a (ASD) for NFPA 13-2016 Editions or Earlier

Structure	Load Orientation	Flange Thickness	Horizontal Load Rating at Brace Angle			
			30°-44°	45°-59°	60°-90°	Listed
Horizontal Steel Flange and Vertical Steel Flange	Parallel to Flange Perpendicular to Flange	0.1875 – 0.249 in (4.76 – 6.32 mm)	500 lbf (2.22 kN)	707 lbf (3.15 kN)	865 lbf (3.85 kN)	1000 lbf (4.45 kN)
		0.250 – 0.499 in (6.35 – 12.67 mm)	800 lbf (3.56 kN)	1131 lbf (5.03 kN)	1385 lbf (6.16 kN)	1600 lbf (7.12 kN)
		0.500 – 0.750 in (12.70 – 19.05 mm)	1007 lbf (4.48 kN)	1425 lbf (6.34 kN)	1744 lbf (7.76 kN)	2015 lbf (8.96 kN)

- 1) Listed for installation with Fig. AF700 & AF771
- 2) Brace Angles are determined from Vertical.
- 3) Listed load ratings reduced for angle ranges in accordance with NFPA 13-2016 Table 9.3.5.2.3.
- 4) Minimum safety factor of 1.5 in accordance with NFPA 13-2016 Section A.9.3.5.2.3.

FIG. AF778 FM Approved (Listing) per FM 1950-13 (ASD)

Structure	Load Orientation	Flange Thickness	Horizontal Load Rating at Brace Angle			
			30°-44°	45°-59°	60°-74°	75°-90°
Horizontal Steel Flange	Parallel to Flange	0.125 – 0.750 in (3.18 – 19.05 mm)	870 lbf (3.87 kN)	1440 lbf (6.14 kN)	1230 lbf (5.47 kN)	1360 lbf (6.05 kN)
	Perpendicular to Flange		1030 lbf (4.58 kN)	2260 lbf (10.05 kN)	2490 lbf (11.08 kN)	2750 lbf (12.23 kN)
Vertical Steel Flange	Parallel to Flange		1280 lbf (5.69 kN)	1840 lbf (8.18 kN)	2210 lbf (9.83 kN)	2470 lbf (10.99 kN)
	Perpendicular to Flange		1570 lbf (6.98 kN)	1490 lbf (6.63 kN)	1040 lbf (4.63 kN)	1150 lbf (5.12 kN)

- 1) Listed for installation with Fig. AF700 & AF771
- 2) Brace Angles are determined from Vertical.
- 3) Listed load ratings reduced for angle ranges in accordance with NFPA 13-2019 Table 18.5.2.3.
- 4) Minimum safety factor of 1.5 in accordance with NFPA 13-2016 Section A.9.3.5.2.3. To convert the load ratings above to a safety factor of 2.2 per NFPA 13-2019 Section A.18.5.2.3, multiply load ratings by a factor of 0.68.
- 5) To convert to LRFD Load Ratings, ASD Load Ratings may be multiplied by a factor of 1.5

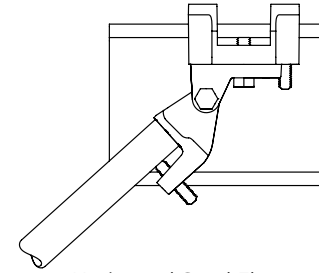

Horizontal Steel Flange
Seismic Load Parallel to Flange

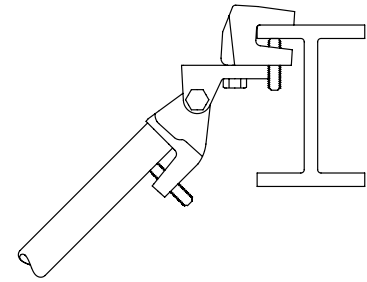

Horizontal Steel Flange
Seismic Load Perpendicular to Flange

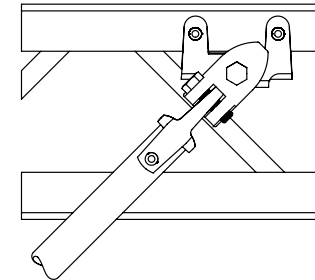

Vertical Steel Flange
Seismic Load Parallel to Flange

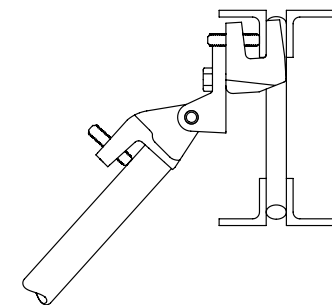

Vertical Steel Flange
Seismic Load Perpendicular to Flange



asc-es.com

Building connections that last™