



I-P100

FIELD INSTALLATION HANDBOOK

Victaulic® QuickVic™ SD Installation-Ready™ System



- **PRODUCT INSTALLATION**
- **INSTALLATION INSPECTION**
- **HELPFUL INFORMATION**

WARNING



- Read and understand all instructions before attempting to install, remove, adjust, or maintain any Victaulic products.
- Always depressurize and drain the piping system before attempting to install, remove, adjust, or maintain any Victaulic products.
- Wear safety glasses, hardhat, foot protection, and hearing protection.

Failure to follow instructions and warnings could cause system failure, resulting in death or serious personal injury and property damage.

Contact Victaulic with any questions regarding the safe and proper installation of products featured in this handbook.

Visit victaulic.com for the most up-to-date information on Victaulic products.

Table of Contents

GENERAL INFORMATION

HAZARD IDENTIFICATION.....	2
INTRODUCTION	2
IMPORTANT INFORMATION	3
GASKET SELECTION.....	4
PIPING SUPPORT.....	4
PIPE PREPARATION REQUIREMENTS.....	5
MINIMUM PIPE NIPPLE LENGTH REQUIREMENTS.....	5
PIPE MARKING REQUIREMENTS	6
Using the PC3110 Cut and Mark Tool.....	6
Using the Insertion Depth Indicators on an Elbow or Tee Fitting.....	6
Using a Ruler or Measuring Tape.....	6
LUBRICATION REQUIREMENTS	7
PIPE INSERTION REQUIREMENTS	8 – 9
IMPACT WRENCH USAGE GUIDELINES.....	10
INSTALLATION VERIFICATION.....	11

INSTALLATION INSTRUCTIONS

NO. P10 (90° ELBOW) QUICKVIC™ SD INSTALLATION-READY™ FITTING FOR PLAIN-END CARBON STEEL PIPE INSTALLATION INSTRUCTIONS.....	13 – 18
NO. P20 (STRAIGHT TEE) QUICKVIC™ SD INSTALLATION-READY™ FITTING FOR PLAIN-END CARBON STEEL PIPE INSTALLATION INSTRUCTIONS.....	19 – 28
STYLE P07 QUICKVIC™ SD INSTALLATION-READY™ COUPLING FOR PLAIN-END CARBON STEEL PIPE INSTALLATION INSTRUCTIONS.....	29 – 32
STYLE P08 QUICKVIC™ SD INSTALLATION-READY™ SLIP COUPLING FOR PLAIN-END CARBON STEEL PIPE INSTALLATION INSTRUCTIONS.....	33 – 38
STYLE P50 QUICKVIC™ SD INSTALLATION-READY™ REDUCING COUPLING FOR PLAIN-END CARBON STEEL PIPE INSTALLATION INSTRUCTIONS.....	39 – 42
NO. P47 (STRAIGHT) AND NO. P97 (90° ELBOW) DIELECTRIC ADAPTERS (PLAIN END X SWEAT) INSTALLATION INSTRUCTIONS.....	43 – 44
SERIES P89 BALL VALVE INSTALLATION AND HANDLE EXTENSION KIT INSTRUCTIONS.....	45 – 46



REUSE INSTRUCTIONS

QUICKVIC™ SD INSTALLATION-READY™ SYSTEM PRODUCTS REUSE INSTRUCTIONS	47 – 58
--	---------

PRODUCT DATA

PRODUCT DATA	59 – 66
--------------------	---------

HELPFUL INFORMATION

ENGLISH TO METRIC CONVERSION CHART	68
METRIC TO ENGLISH CONVERSION CHART	68
DECIMAL EQUIVALENTS OF FRACTIONS	69
PRESSURE TO FEET-OF-HEAD OF WATER	70
FEET-OF-HEAD OF WATER TO PRESSURE.....	70
PRESSURE TO METER WATER COLUMN	71
METER WATER COLUMN TO PRESSURE	71
WHERE TO FIND INSTALLATION INSTRUCTIONS FOR ADDITIONAL PRODUCTS.....	72 – 75



General Information

HAZARD IDENTIFICATION

Definitions for identifying the various hazard levels are provided below.



This safety alert symbol indicates important safety messages. When you see this symbol, be alert to the possibility of personal injury. Carefully read and fully understand the message that follows.

DANGER

- The use of the word “DANGER” identifies an immediate hazard with a likelihood of death or serious personal injury if instructions, including recommended precautions, are not followed.

WARNING

- The use of the word “WARNING” identifies the presence of hazards or unsafe practices that could result in death or serious personal injury if instructions, including recommended precautions, are not followed.

CAUTION

- The use of the word “CAUTION” identifies possible hazards or unsafe practices that could result in personal injury and product or property damage if instructions, including recommended precautions, are not followed.

NOTICE

- The use of the word “NOTICE” identifies special instructions that are important but not related to hazards.

INTRODUCTION

This I-P100 Field Installation Handbook contains important information regarding pipe preparation and installation of Victaulic® QuickVic™ SD Installation-Ready™ System products for carbon steel pipe.

In addition to this I-P100, Victaulic offers field installation handbooks, installation sheets, or installation tags for mechanical piping products that join alternate piping materials or that work with other dedicated groove profile technologies. These instructions are shipped with the applicable product and can be downloaded at victaulic.com.

Always follow good piping practices. Specified pressures, temperatures, external loads, internal loads, performance standards, and tolerances shall never be exceeded.

Many applications require recognition of special conditions, code requirements, and the use of safety factors. Qualified engineers shall reference Victaulic publication 05.01, “Seal Selection Guide,” when determining requirements for special applications. This publication can be downloaded at victaulic.com.



SCAN QR CODE FOR ADDITIONAL
FIELD INSTALLATION HANDBOOKS
THAT VICTAULIC OFFERS

NOTICE

- Victaulic maintains a continual policy of product improvement. Therefore, Victaulic reserves the right to change product specifications, designs, and standard equipment without notice and without incurring obligation.
- **VICTAULIC IS NOT RESPONSIBLE FOR SYSTEM DESIGN, NOR DO THEY ASSUME ANY RESPONSIBILITY FOR SYSTEMS THAT ARE DESIGNED IMPROPERLY.**
- This handbook is not intended to be a substitute for competent, professional assistance, which is a prerequisite for any product application.
- The information published in this handbook and other Victaulic literature supersedes all previously published information.
- Drawings and/or pictures in this manual may be exaggerated for clarity.
- The field installation handbook contains trademarks, copyrights, and products with patented features that are the exclusive property of Victaulic.
- **WHILE EVERY EFFORT HAS BEEN MADE TO ENSURE ITS ACCURACY, VICTAULIC, ITS SUBSIDIARIES, AND ITS AFFILIATED COMPANIES MAKE NO EXPRESSED OR IMPLIED WARRANTY OF ANY KIND REGARDING THE INFORMATION CONTAINED OR REFERENCED IN THIS HANDBOOK. ANYONE WHO USES THE INFORMATION CONTAINED HEREIN DOES SO AT THEIR RISK AND ASSUMES ANY LIABILITY THAT RESULTS FROM SUCH USE.**

IMPORTANT INFORMATION

QuickVic™ SD Installation-Ready™ products shall be used only for joining Schedules 10 – 80 carbon steel pipe (150 Brinell Hardness Number [BHN] maximum) in ½-inch/DN15, ¾-inch/DN20, 1-inch/DN25, 1 ¼-inch/DN32, 1 ½-inch/DN40, and 2-inch/DN50 sizes. Refer to the table below for the allowable pipe outside diameter dimensions that can be used with QuickVic™ SD Installation-Ready™ products.

For complete material specifications and application information, always reference Victaulic publication 34.01, which can be downloaded at victaulic.com.

Allowable Pipe Outside Diameter Dimensions

Nominal Diameter inches/DN	Actual Pipe Outside Diameter inches/mm	Allowable Pipe Outside Diameter Dimensions – inches/mm	
		Maximum	Minimum
½ DN15	0.840 21.3	0.855 21.7	0.825 21.0
¾ DN20	1.050 26.9	1.065 27.1	1.035 26.3
1 DN25	1.315 33.7	1.330 33.8	1.300 33.0
1 ¼ DN32	1.660 42.4	1.675 42.5	1.645 41.8
1 ½ DN40	1.900 48.3	1.915 48.6	1.885 47.9
2 DN50	2.375 60.3	2.406 61.1	2.344 59.5

Canadian Customers – CSA B51 Compliance: For applications within the scope of CSA B51, “Boiler, Pressure Vessel and Pressure Piping Code,” please contact Victaulic for the most up-to-date Canadian Registration Numbers, approved products, and temperature ratings.



GASKET SELECTION

CAUTION

- Always specify the proper gasket material grade for the intended service. Failure to select the proper gasket material grade for the service may cause joint leakage, resulting in property damage.

Do not subject gaskets to temperatures beyond the specified limits. Excessive temperatures will degrade gasket performance. Prior to product installation, check the gasket to verify that it is suitable for the intended service. The color code identifies the gasket grade. For complete information, always refer to Victaulic publication 05.01, "Seal Selection Guide," which can be downloaded at victaulic.com.

Gasket Color Code Reference

Grade	Compound	Color Code
EHP	EPDM	Red and Green Stripes
T	Nitrile	Orange Stripe

PIPING SUPPORT

WARNING

- These values are not intended to be used as specifications for all installations, and they DO NOT apply where critical calculations are made or where there are concentrated loads between supports.
 - DO NOT use piping joined with QuickVic™ SD Installation-Ready™ products as a lift point. DO NOT climb or hang on pipe joined with these products.
- Failure to follow these instructions could cause joint failure, resulting in death or serious personal injury and property damage.

Piping that is joined with QuickVic™ SD Installation-Ready™ products requires support to carry the weight of pipes and equipment. The support or hanging method shall eliminate stress on joints, piping, piping contents (fluids), and other components. In addition, the method of support shall allow for pipeline movement, where required, along with other design requirements, such as drainage.





The following tables list the suggested maximum span between pipe supports for horizontal, straight runs of pipe carrying water or similar liquids.

Piping Support for Schedules 10 – 80 Carbon Steel Pipe

Nominal inches/DN	Actual Outside Diameter inches/mm	Suggested Maximum Span Between Supports feet/meters			
		Water Service		Air Service	
		B31.1	B31.9	B31.1	B31.9
½ DN15	0.840 21.3	6 1.8	7 2.1	8 2.4	7 2.1
¾ DN20	1.050 26.9	7 2.1	8 2.4	9 2.7	8 2.4
1 DN25	1.315 33.7	7 2.1	9 2.7	9 2.7	9 2.7
1¼ DN32	1.660 42.4	7 2.1	11 3.4	9 2.7	11 3.4
1½ DN40	1.900 48.3	7 2.1	12 3.7	9 2.7	13 4.0
2 DN50	2.375 60.3	10 3.1	13 4.0	13 4.0	15 4.6

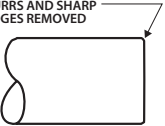
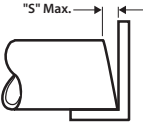

PIPE PREPARATION REQUIREMENTS

<p>ACCEPTABLE</p> <p>BURRS AND SHARP EDGES REMOVED</p>  <p>The pipe OD shall not contain burrs, sharp edges, raised weld beads, axial score marks, scratches, or indentations a minimum of 2 inches/51 mm back from the pipe end. All oil, grease, loose paint, dirt, and cutting particles shall be removed.</p> <p>"S" Max.</p>  <p>Pipe ends shall be square cut ("S" dimension shown) within 0.030 inch/0.8 mm.</p>	<p>NOT ACCEPTABLE</p>  <p>Excessive chamfer on the pipe ID will cut the gasket during assembly. Excessive chamfer is not acceptable.</p>
<p>NOT ACCEPTABLE</p>  <p>Abrasive wheels and saws will leave edges on pipe ends that are pronounced on one side. Burrs and sharp edges are not acceptable.</p>	<p>NOT ACCEPTABLE</p>  <p>Dull wheel cutters will push ridges up at the pipe OD, resulting in an oversized pipe diameter. Oversized pipe diameters are not acceptable.</p>

MINIMUM PIPE NIPPLE LENGTH REQUIREMENTS

⚠ WARNING

- Carbon steel pipe for use with QuickVic™ SD Installation-Ready™ products shall meet the minimum pipe-nipple length requirements specified in the table below. Failure to follow these instructions could cause joint failure, resulting in death or serious personal injury and property damage.

QuickVic™ SD Installation-Ready™ products require that the pipe be inserted to the appropriate depth to ensure satisfactory performance (refer to the "Insertion Depth Requirements" table on the following page).

The following table provides the minimum length necessary to ensure adequate insertion depth and clearance for back-to-back coupling/fitting installation. **NOTE:** Pipe nipple lengths shorter than 3 3/8 inches/86 mm will require manual marking of pipe (refer to the "Insertion Depth Requirements" table on the following page).

Nominal inches/DN	Actual Outside Diameter inches/mm	Minimum Pipe Nipple Length Required inches/mm
1/2 – 1 1/4 DN15 – DN32	0.840 – 1.660 21.3 – 42.4	2 3/8 60
1 1/2 – 2 DN40 – DN50	1.900 – 2.375 48.3 – 60.3	3 1/8 79

PIPE MARKING REQUIREMENTS

⚠ WARNING

- Insertion depth shall be measured and marked on each pipe end for visual confirmation that the pipe is inserted fully into the coupling or fitting. Failure to follow this instruction could cause joint failure, resulting in death or serious personal injury and property damage.

There are three methods that can be used to make the required insertion depth mark on pipe for QuickVic™ SD Installation-Ready™ products.

Using the PC3110 Cut and Mark Tool

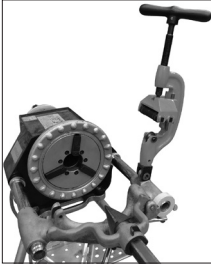

The Victaulic PC3110 Cut and Mark Tool is a portable tool that operates with a power drive for preparing pipe to receive QuickVic™ SD Installation-Ready™ products. The PC3110 tool is designed to cut and mark ½ – 2-inch/DN15 – DN50 Schedules 10 – 80 carbon steel pipe.

For complete setup and operating instructions for this tool, refer to the TM-PC3110, which can be downloaded at victaulic.com.

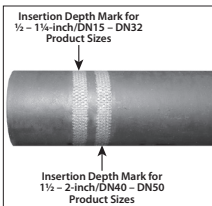

The PC3110 automatically produces two knurled marks on the pipe end at the required insertion depth.

The mark closest to the pipe end indicates the required insertion depth for ½ – 1 ¼-inch/DN15 – DN32 product sizes, as shown.

The second mark indicates the required insertion depth for 1 ½ – 2-inch/DN40 – DN50 product sizes, as shown.

Using the Insertion Depth Indicators on an Elbow or Tee Fitting

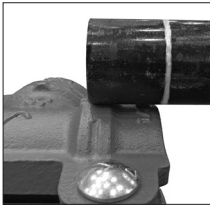
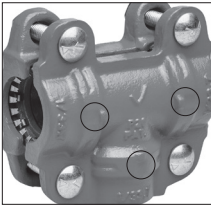

Each elbow or tee fitting contains an insertion depth indicator at each pipe insertion location, as shown. Place the pipe end up against the raised portion of the fitting, and place a mark around the entire pipe circumference with a marker or paint pen at this required insertion depth.

Using a Ruler or Measuring Tape

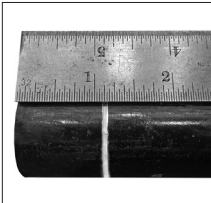

Refer to the table below for the insertion depth requirements. Using a ruler or measuring tape, measure back from the pipe end. Place a mark around the entire pipe circumference with a marker or paint pen, as shown.

Insertion Depth Requirements

Nominal inches/DN	Actual Outside Diameter inches/mm	Insertion Depth Requirements inches/mm
½ – 1 ¼ DN15 – DN32	0.840 – 1.660 21.3 – 42.4	1 ⅛ 29
1 ½ – 2 DN40 – DN50	1.900 – 2.375 48.3 – 60.3	1 ½ 38

LUBRICATION REQUIREMENTS

CAUTION

- A thin coat of a compatible lubricant, such as Victaulic Lubricant or silicone lubricant, shall be used on the pipe ends or sealing lips of the gasket to prevent the gasket from pinching, rolling, or tearing during installation.

Failure to use a compatible lubricant will cause gasket damage, resulting in joint leakage and property damage.



Lubrication of the pipe ends or sealing lips of the gasket with a thin coating of a compatible lubricant, such as Victaulic Lubricant or silicone lubricant, is required to prevent the gasket from pinching, rolling, or tearing during product installation. In addition, lubrication eases installation of the gasket onto the pipe end. Refer to Victaulic publication 05.02 for the Victaulic Lubricant Safety Data Sheet (SDS), which can be downloaded at victaulic.com.

PIPE INSERTION REQUIREMENTS

1/2 – 1 1/4-inch/DN15 – DN32 Product Sizes Marked with the PC3110 Cut and Mark Tool

Prior to tightening any hardware, verify that the pipe marks indicate full insertion into the coupling or fitting, as shown in the examples below.

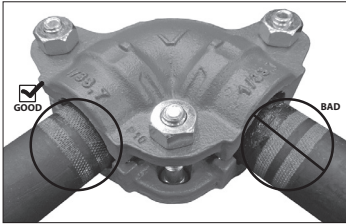
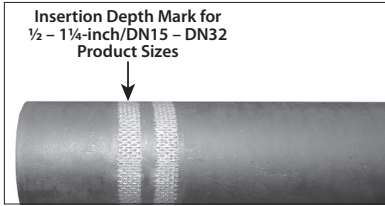

Example P10

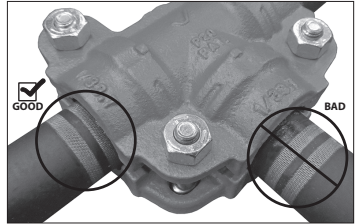

Example P20

1 1/2 – 2-inch/DN40 – DN50 Product Sizes Marked with the PC3110 Cut and Mark Tool

Prior to tightening any hardware, verify that the pipe marks indicate full insertion into the coupling or fitting, as shown in the examples below.

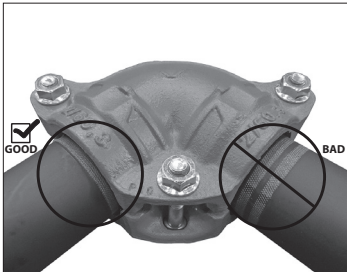
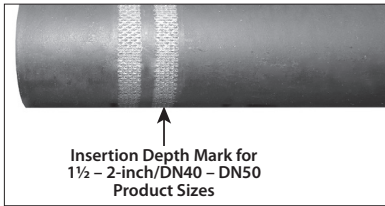

Example P10



Example P10

PIPE INSERTION REQUIREMENTS (CONTINUED)

Pipe Marked by Using a Marker or Paint Pen

Prior to tightening any hardware, verify that the pipe marks indicate full insertion into the coupling or fitting, as shown in the examples below.

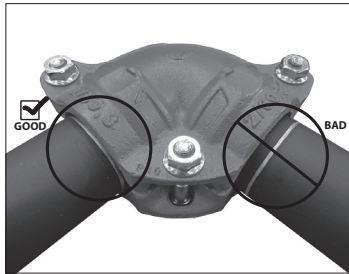

Example P10

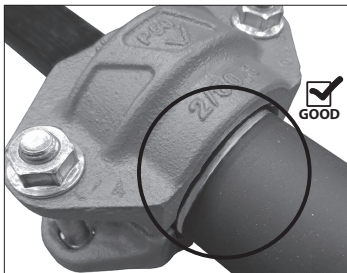

Example P50

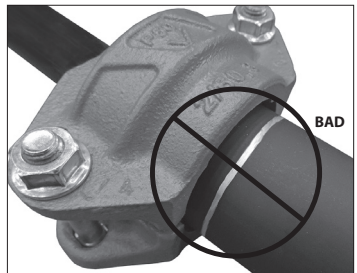

Example P50

IMPACT WRENCH USAGE GUIDELINES

WARNING

- The nut shall be tightened until metal-to-metal contact occurs at the bolt pads.
- **DO NOT** continue to tighten the hardware after the visual installation guidelines for the product, described in the applicable installation section of this handbook, are achieved.

Failure to follow these instructions could cause joint failure, resulting in death or serious personal injury and property damage.

Impact wrenches do not provide the installer with direct “wrench feel” or torque to judge nut tightness. Since some impact wrenches are capable of high output, it is important to develop a familiarity with the impact wrench to avoid damaging or fracturing the bolts or the bolt pads during installation. **Always choose the right size impact wrench that has enough power, but DO NOT continue to tighten the hardware after the visual installation guidelines for the product, described in the applicable installation section of this handbook, are achieved. If you suspect that any hardware has been over-tightened (as indicated by a bend or crack in the bolt, etc.), the hardware shall be replaced immediately.**

If the battery is drained or if the impact wrench is under-powered, a new battery pack or new impact wrench shall be used to ensure that the visual installation guidelines for the product, described in the applicable installation section of this handbook, are achieved.

Visual inspection of each joint is required for verification of proper assembly.

Perform trial assemblies with the impact wrench and check the assemblies with a torque wrench to help determine the suitability of the impact wrench. Using the same method, periodically check assemblies throughout the system installation.

For safe and proper use of impact wrenches, always refer to the impact wrench manufacturer’s operating instructions. In addition, verify that proper impact grade sockets are being used for coupling installation.

WARNING

Failure to follow instructions for tightening hardware could result in:

- Personal injury or death
- Bolt damage or fracture
- Damaged or broken bolt pads or fractures to housings
- Joint leakage and property damage

INSTALLATION VERIFICATION

Prior to initial system test, verify that the following installation requirements have been achieved.

Verify that Pipe Marks Indicate Full Insertion Into the Coupling or Fitting – Refer to the “Pipe Insertion Requirements” section on pages 8 – 9 for examples.

Verify that Metal-To-Metal Bolt Contact is Achieved at Each Bolt Pad – Refer to the applicable installation section of this manual for examples. If metal-to-metal bolt pad contact cannot be achieved, verify that the pipe tolerances are within Victaulic specifications. Contact Victaulic with any questions concerning installation.

Verify that Retainers are Installed Within the Housings – QuickVic™ SD Installation-Ready™ couplings and fittings contain “windows” that can be used to verify the presence of retainers after the product is installed on pipe. **If a retainer is not visible through a window after the product is installed on pipe:** If a retainer is missing, the coupling or fitting shall be removed so that a retainer can be installed (refer to the “Reuse Instructions” section starting on page 47 of this handbook), or the coupling or fitting shall be removed and replaced completely.

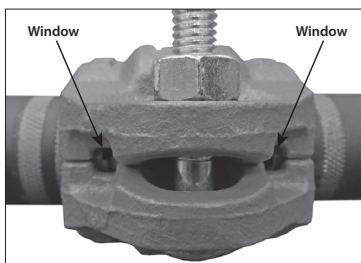

WARNING



- Always depressurize and drain the piping system before attempting to install, remove, adjust, or maintain any Victaulic piping products.
Failure to follow this instruction could result in death or serious personal injury and property damage.

Patented “Leak-if-Not-Tightened” Technology – QuickVic™ SD Installation-Ready™ products are designed with a feature that will allow the joint to leak during an initial system test (following the first assembly of the product on pipe) if the hardware is not tightened adequately. If any leakage occurs during the initial system test, the system shall be depressurized and drained completely so that the installer can tighten the hardware to achieve metal-to-metal bolt pad contact or to correct any other misassembly condition.



No. P10 (90° Elbow) QuickVic™ SD Installation-Ready™ Fitting for Plain-End Carbon Steel Pipe

Installation Instructions



No. P10 (90° Elbow) – QuickVic™ SD Installation-Ready™ Fitting for Plain-End Carbon Steel Pipe

! WARNING



- Read and understand all instructions before attempting to install, remove, adjust, or maintain any Victaulic piping products.
 - Always depressurize and drain the piping system before attempting to install, remove, adjust, or maintain any Victaulic piping products.
 - Wear safety glasses, hardhat, and foot protection.
- Failure to follow these instructions could result in death or serious personal injury and property damage.

Verify that the following instructions in the “General Information” section have been followed:

- Pipe Preparation Requirements
- Minimum Pipe Nipple Length Requirements
- Pipe Marking Requirements
- Lubrication Requirements

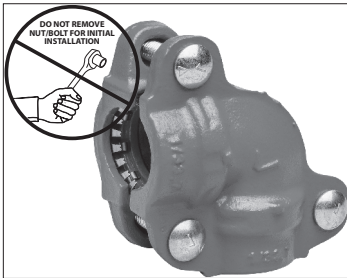

DO NOT DISASSEMBLE THE NO. P10 FOR INITIAL INSTALLATION: The No. P10 is designed so that the installer does not need to remove the bolts and nuts for installation. This facilitates assembly by allowing the installer to directly install the No. P10 onto marked plain-end pipe.

! WARNING



- Never leave a No. P10 partially assembled. **ALWAYS TIGHTEN THE HARDWARE IMMEDIATELY.** A partially assembled No. P10 poses a drop or fall hazard during installation and a burst hazard during testing.
 - Keep hands away from the opening of the No. P10 when attempting to insert marked plain-end pipe. Retainer teeth are sharp and may cause injury.
- Failure to follow these instructions could result in serious personal injury and property damage.

INSTALLATION METHOD 1



1. INSERT FIRST PIPE END: Assemble the joint by inserting a marked plain-end pipe into one opening of the No. P10. Verify that the pipe is inserted until the mark indicates full insertion into the fitting, as shown. Refer to the “Pipe Insertion Requirements” section on pages 8 – 9.



1a. TIGHTEN NUT AT FIRST OUTSIDE LOCATION: Using an impact wrench or standard socket wrench with a deep-well socket, tighten the nut at the corresponding location until metal-to-metal contact occurs at the bolt pad. Verify that the pipe mark indicates full insertion into the fitting and that the oval neck of the bolt seats properly in the bolt hole. Refer to the “No. P10 Helpful Information” table on the following page and the “Impact Wrench Usage Guidelines” section on page 10.

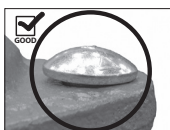

OVAL NECK OF BOLT SEATED PROPERLY



OVAL NECK OF BOLT NOT SEATED PROPERLY

WARNING

- At this point, the fitting is only partially installed.
- The fitting shall be treated as a potential drop hazard and shall not be left unattended.

Failure to follow these instructions could result in death or serious personal injury and property damage.



2. INSERT SECOND PIPE END: Insert the second marked plain-end pipe into the other opening of the fitting. Verify that the pipe is inserted until the mark indicates full insertion into the fitting. Refer to the “Pipe Insertion Requirements” section on pages 8 – 9.



2a. COMPLETELY TIGHTEN NUT AT INSIDE LOCATION: Completely tighten the nut at the corresponding location until metal-to-metal contact occurs at the bolt pad. Verify that the pipe marks indicate full insertion into the fitting and that the oval neck of the bolt seats properly in the bolt hole.



3. COMPLETELY TIGHTEN NUT AT SECOND OUTSIDE LOCATION: Completely tighten the nut at the corresponding location until metal-to-metal contact occurs at the bolt pad. Verify that the pipe marks indicate full insertion into the fitting and that the oval neck of the bolt seats properly in the bolt hole.



4. COMPLETELY TIGHTEN NUT AT FIRST OUTSIDE LOCATION: Go back and completely tighten the nut at the first outside location to confirm metal-to-metal contact at the bolt pads. Verify that the pipe marks indicate full insertion into the fitting and that the oval neck of each bolt seats properly in the bolt hole.

! WARNING

- Nuts shall be tightened in the sequence shown on pages 15 – 16 until metal-to-metal contact occurs at all bolt pads.

Failure to follow instructions for tightening hardware could result in:

- Personal injury or death
- Bolt damage or fracture
- Damaged or broken bolt pads or fractures to housings
- Joint leakage and property damage

NO. P10 HELPFUL INFORMATION

Nominal inches/DN	Actual Outside Diameter inches/mm	Bolt Size inches/Metric	Deep-Well Socket Size inches/mm
½ – 1 ½ DN15 – DN40	0.840 21.3	⅜ M10	1 1/16 17
2 DN50	2.375 60.3	7/16 M11	1 1/16 17

⚠ WARNING

- Visual inspection of each joint is required.
- Improperly assembled joints shall be corrected before the system is tested or placed into service.
- Any components that exhibit physical damage due to improper assembly shall be replaced.

Failure to follow these instructions could cause joint failure, resulting in death or serious personal injury and property damage.

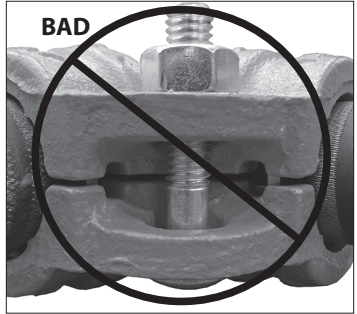
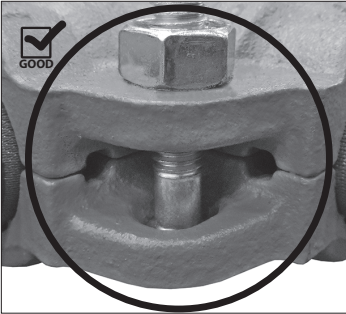

5. VERIFY THAT ALL NUTS ARE TIGHTENED COMPLETELY AND THAT METAL-TO-METAL CONTACT IS ACHIEVED AT ALL BOLT PADS: Visually inspect all bolt pads at each joint to verify that metal-to-metal contact is achieved.

INSTALLATION METHOD 2



1. When practical, both marked plain-end pipes may be inserted into the fitting prior to tightening. In this case, the hardware shall be tightened evenly by alternating sides until the installation requirements listed in these instructions are achieved.



I-P100_18

No. P20 (Straight Tee) QuickVic™ SD Installation-Ready™ Fitting for Plain-End Carbon Steel Pipe

Installation Instructions



½ – ¾-INCH/DN15 – DN20 SIZES WITH
3-BOLT CONFIGURATION



1 – 2-INCH/DN25 – DN50 SIZES WITH
4-BOLT CONFIGURATION

No. P20 (Straight Tee) – QuickVic™ SD Installation-Ready™ Fitting for

Plain-End Carbon Steel Pipe

½ – ¾-inch/DN15 – DN20 Sizes with 3-Bolt Configuration

1 – 2-inch/DN25 – DN50 Sizes with 4-Bolt Configuration

! WARNING



- Read and understand all instructions before attempting to install, remove, adjust, or maintain any Victaulic piping products.
 - Always depressurize and drain the piping system before attempting to install, remove, adjust, or maintain any Victaulic piping products.
 - Wear safety glasses, hardhat, and foot protection.
- Failure to follow these instructions could result in death or serious personal injury and property damage.

Verify that the following instructions in the
“General Information” section have been followed:

Pipe Preparation Requirements
Minimum Pipe Nipple Length Requirements
Pipe Marking Requirements
Lubrication Requirements

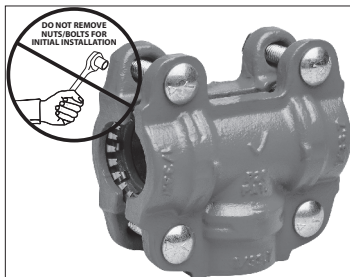

DO NOT DISASSEMBLE THE NO. P20 FOR INITIAL INSTALLATION: The No. P20 is designed so that the installer does not need to remove the bolts and nuts for installation. This facilitates assembly by allowing the installer to directly install the No. P20 onto marked plain-end pipe.

! WARNING



- Never leave a No. P20 partially assembled. **ALWAYS TIGHTEN THE HARDWARE IMMEDIATELY.** A partially assembled No. P20 poses a drop or fall hazard during installation and a burst hazard during testing.
 - Keep hands away from the opening of the No. P20 when attempting to insert marked plain-end pipe. Retainer teeth are sharp and may cause injury.
- Failure to follow these instructions could result in serious personal injury and property damage.



QUICKVIC™ SD INSTALLATION-READY™ SYSTEM
FOR PLAIN-END CARBON STEEL PIPE
INSTALLATION INSTRUCTIONS REV_A

INSTALLATION METHOD 1 – PIPE INSERTED INTO RUN ENDS FIRST

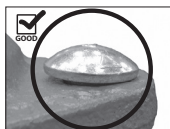
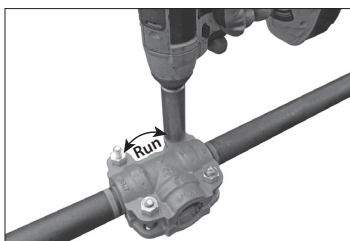
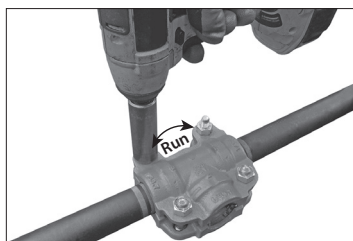

OVAL NECK OF BOLT
SEATED
PROPERLY



OVAL NECK OF BOLT
NOT SEATED
PROPERLY

1. INSERT PIPE INTO RUN ENDS: Insert a marked plain-end pipe into each run end of the fitting. Verify that each pipe is inserted until the mark indicates full insertion into the fitting. Refer to the “Pipe Insertion Requirements” section on pages 8 – 9.

1a. TIGHTEN NUT(S) ALONG THE RUN SIDE: Using an impact wrench or standard socket wrench with a deep-well socket, tighten the nut(s) along the run side until metal-to-metal contact occurs at the bolt pads. Verify that the pipe marks indicate full insertion into the fitting and that the oval neck of the bolt(s) seats properly in the bolt hole. Refer to the “No. P20 Helpful Information” table on the following page and the “Impact Wrench Usage Guidelines” section on page 10.

WARNING

- At this point, the fitting is only partially installed.
- The fitting shall be treated as a potential drop hazard and shall not be left unattended.

Failure to follow these instructions could result in death or serious personal injury and property damage.

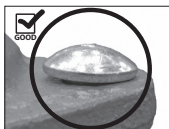
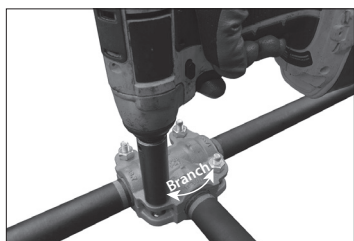

OVAL NECK OF BOLT SEATED PROPERLY



OVAL NECK OF BOLT NOT SEATED PROPERLY

2. INSERT PIPE INTO BRANCH END: Insert the third marked plain-end pipe into the opening of the branch end. Verify that the pipe mark indicates full insertion into the fitting. Refer to the “Pipe Insertion Requirements” section on pages 8 – 9.

2a. TIGHTEN NUTS ALONG THE BRANCH SIDE: Tighten the nuts along the branch side until metal-to-metal contact occurs at the bolt pads. Verify that the pipe mark indicates full insertion into the fitting and that the oval neck of each bolt seats properly in the bolt hole.

NO. P20 HELPFUL INFORMATION

Nominal inches/DN	Actual Outside Diameter inches/mm	Bolt Size inches/Metric	Deep-Well Socket Size inches/mm
½ – 1 ½ DN15 – DN40	0.840 21.3	¾ M10	1 ¼ 17
2 DN50	2.375 60.3	7/16 M11	1 ¼ 17

WARNING

- Nuts shall be tightened in the sequence shown on pages 21 – 23 until metal-to-metal contact occurs at the bolt pads.

Failure to follow instructions for tightening hardware could result in:

- Personal injury or death
- Bolt damage or fracture
- Damaged or broken bolt pads or fractures to housings
- Joint leakage and property damage

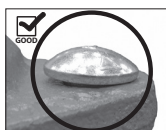
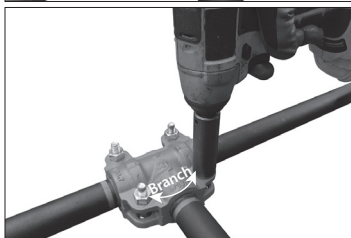
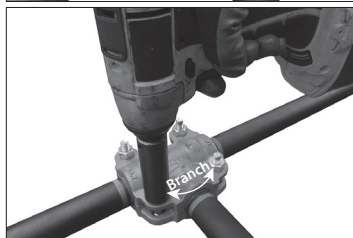
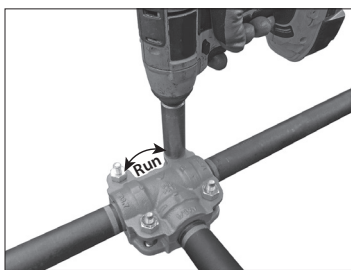
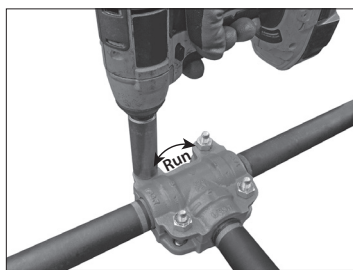

OVAL NECK OF BOLT SEATED PROPERLY



OVAL NECK OF BOLT NOT SEATED PROPERLY

3. CONFIRM THAT ALL NUTS ARE TIGHTENED: Go back and tighten all nuts to confirm metal-to-metal contact at the bolt pads. Verify that the mark on each pipe indicates full insertion into the fitting and that the oval neck of each bolt seats properly in the bolt hole.

⚠ WARNING

- Visual inspection of each joint is required.
- Improperly assembled joints shall be corrected before the system is tested or placed into service.
- Any components that exhibit physical damage due to improper assembly shall be replaced.

Failure to follow these instructions could cause joint failure, resulting in death or serious personal injury and property damage.

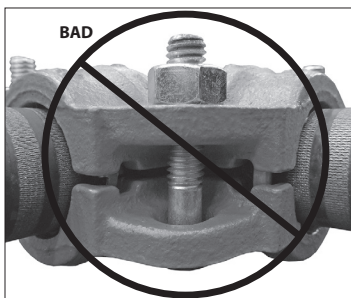
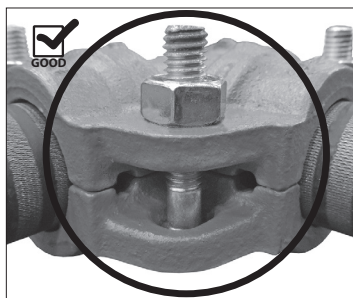

4. VERIFY THAT ALL NUTS ARE TIGHTENED APPROPRIATELY AND THAT METAL-TO-METAL CONTACT IS ACHIEVED AT ALL BOLT PADS: Visually inspect all bolt pads at each joint to verify that metal-to-metal contact is achieved.

INSTALLATION METHOD 2 – PIPE INSERTED INTO BRANCH END FIRST

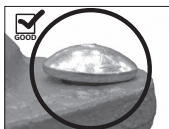

OVAL NECK OF BOLT
SEATED
PROPERLY



OVAL NECK OF BOLT
NOT SEATED
PROPERLY

1. INSERT PIPE INTO BRANCH END: Insert a marked plain-end pipe into the opening of the branch end. Verify that the pipe mark indicates full insertion into the fitting. Refer to the “Pipe Insertion Requirements” section on pages 8 – 9.

1a. TIGHTEN NUTS ALONG THE BRANCH SIDE EVENLY JUST UNTIL FITTING IS SECURED TO PIPE: Tighten the nuts along the branch side evenly just until the fitting is secured to the pipe. Verify that the pipe mark indicates full insertion into the fitting and that the oval neck of each bolt seats properly in the bolt hole. Refer to the “No. P20 Helpful Information” table on the following page and the “Impact Wrench Usage Guidelines” section on page 10.

WARNING

- At this point, the fitting is only partially installed.
- The fitting shall be treated as a potential drop hazard and shall not be left unattended.

Failure to follow these instructions could result in death or serious personal injury and property damage.

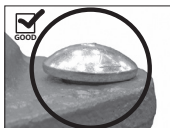
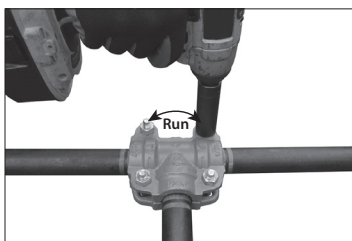
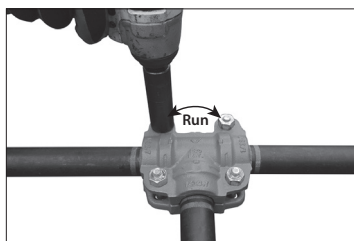

OVAL NECK OF BOLT SEATED PROPERLY



OVAL NECK OF BOLT NOT SEATED PROPERLY

2. INSERT PIPE INTO RUN ENDS: Insert a marked plain-end pipe into each run end of the fitting. Verify that each pipe is inserted until the mark indicates full insertion into the fitting. Refer to the “Pipe Insertion Requirements” section on pages 8 – 9. **NOTE:** If the pipe ends cannot be inserted into the fitting, incrementally loosen the nut(s) that were tightened in step 1a just until each pipe end can be inserted (refer to the warning on the previous page).

2a. TIGHTEN NUT(S) ALONG THE RUN SIDE: Using an impact wrench or standard socket wrench with a deep-well socket, tighten the nut(s) along the run side until metal-to-metal contact occurs at the bolt pads. Verify that the pipe marks indicate full insertion into the fitting and that the oval neck of the bolt(s) seat properly in the bolt hole. Refer to the “No. P20 Helpful Information” table below and the “Impact Wrench Usage Guidelines” section on page 10.

NO. P20 HELPFUL INFORMATION

Nominal inches/DN	Actual Outside Diameter inches/mm	Bolt Size inches/Metric	Deep-Well Socket Size inches/mm
½ – 1 ½ DN15 – DN40	0.840 21.3	¾ M10	1 ¼ 17
2 DN50	2.375 60.3	7/16 M11	1 ¼ 17

! WARNING

- Nuts shall be tightened in the sequence shown on pages 24 – 25 until metal-to-metal contact occurs at the bolt pads.
- Failure to follow instructions for tightening hardware could result in:
- Personal injury or death
 - Bolt damage or fracture
 - Damaged or broken bolt pads or fractures to housings
 - Joint leakage and property damage

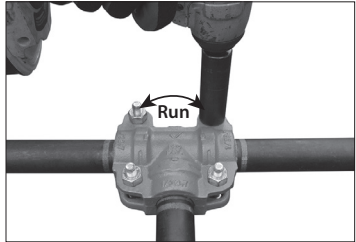
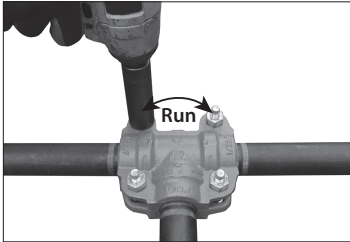
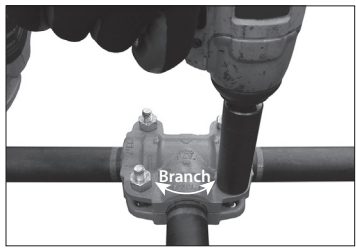
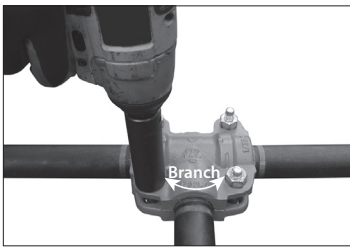

OVAL NECK OF BOLT SEATED PROPERLY



OVAL NECK OF BOLT NOT SEATED PROPERLY

3. CONFIRM THAT ALL NUTS ARE TIGHTENED: Go back and tighten all nuts to confirm metal-to-metal contact at the bolt pads. Verify that the mark on each pipe indicates full insertion into the fitting and that the oval neck of each bolt seats properly in the bolt hole.

WARNING

- Visual inspection of each joint is required.
- Improperly assembled joints shall be corrected before the system is tested or placed into service.
- Any components that exhibit physical damage due to improper assembly shall be replaced.

Failure to follow these instructions could cause joint failure, resulting in death or serious personal injury and property damage.

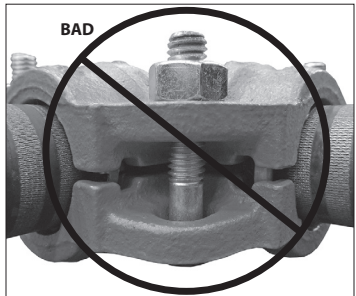
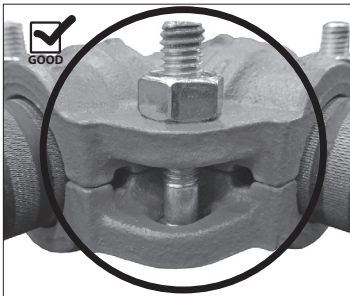

4. VERIFY THAT ALL NUTS ARE TIGHTENED APPROPRIATELY AND THAT METAL-TO-METAL CONTACT IS ACHIEVED AT ALL BOLT PADS: Visually inspect all bolt pads at each joint to verify that metal-to-metal contact is achieved.

INSTALLATION METHOD 3 – ALL PIPES INSERTED

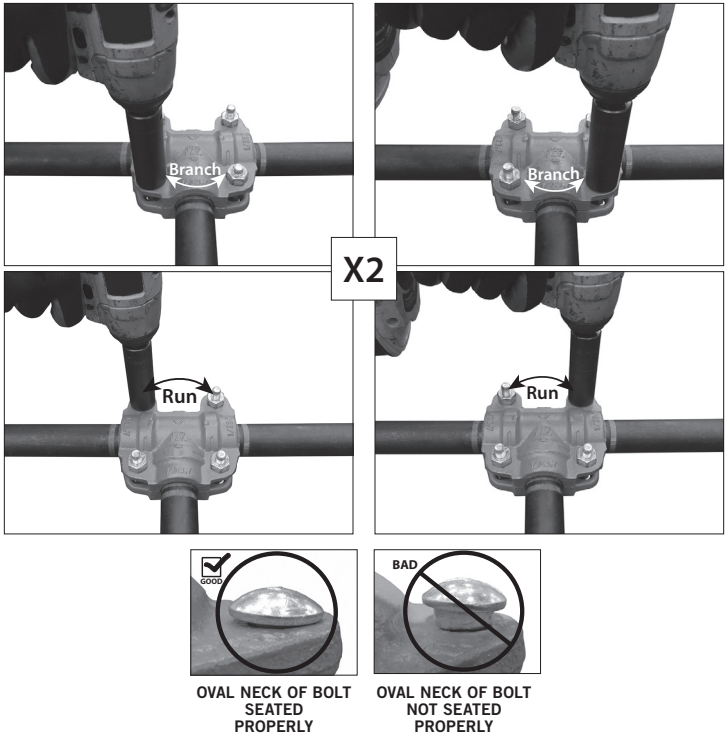

When practical, all marked plain-end pipes may be inserted into the fitting prior to tightening.

1. Tighten nuts along branch side until metal-to-metal bolt pad contact is achieved.
2. Tighten nut(s) along run side until metal-to-metal bolt pad contact is achieved.
3. Go back and tighten all nuts to confirm metal-to-metal contact at the bolt pads. Verify that the mark on each pipe indicates full insertion into the fitting and that the oval neck of each bolt seats properly in the bolt hole.
4. **VERIFY THAT ALL NUTS ARE TIGHTENED APPROPRIATELY AND THAT METAL-TO-METAL CONTACT IS ACHIEVED AT ALL BOLT PADS:** Visually inspect all bolt pads at each joint to verify that metal-to-metal contact is achieved, as shown in step 4 on the previous page.



I-P100_28

Style P07 QuickVic™ SD Installation-Ready™ Coupling for Plain-End Carbon Steel Pipe

Installation Instructions



Style P07 – QuickVic™ SD Installation-Ready™ Coupling for Plain-End Carbon Steel Pipe

! WARNING



- Read and understand all instructions before attempting to install, remove, adjust, or maintain any Victaulic piping products.
 - Always depressurize and drain the piping system before attempting to install, remove, adjust, or maintain any Victaulic piping products.
 - Wear safety glasses, hardhat, and foot protection.
- Failure to follow these instructions could result in death or serious personal injury and property damage.

Verify that the following instructions in the “General Information” section have been followed:

- Pipe Preparation Requirements
- Minimum Pipe Nipple Length Requirements
- Pipe Marking Requirements
- Lubrication Requirements

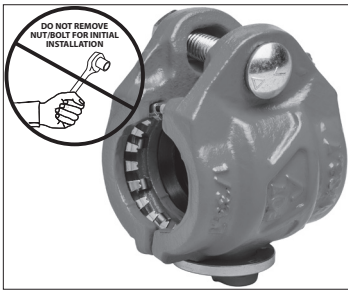

DO NOT DISASSEMBLE THE STYLE P07 FOR THE INITIAL INSTALLATION: The Style P07 is designed so that the installer does not need to remove the bolt, nut, or linkage for installation. This facilitates assembly by allowing the installer to directly install the Style P07 onto marked plain-end pipe.

! WARNING



- Never leave a Style P07 partially assembled. **ALWAYS TIGHTEN THE HARDWARE IMMEDIATELY.** A partially assembled Style P07 poses a drop or fall hazard during installation and a burst hazard during testing.
 - Keep hands away from the opening of the Style P07 when attempting to insert marked plain-end pipe. Retainer teeth are sharp and may cause injury.
- Failure to follow these instructions could result in serious personal injury and property damage.



1. ASSEMBLE JOINT: Assemble the joint by inserting a marked plain-end pipe into each opening of the Style P07. Verify that the pipe is inserted until the mark indicates full insertion into the coupling, as shown. Refer to the “Pipe Insertion Requirements” section on pages 8 – 9.

⚠ WARNING

- The nut shall be tightened until metal-to-metal contact occurs at the bolt pads. Failure to follow instructions for tightening hardware could result in:
 - Personal injury or death
 - Bolt damage or fracture
 - Damaged or broken bolt pads or fractures to housings
 - Joint leakage and property damage



2. TIGHTEN NUT: Using an impact wrench or standard socket wrench with a deep-well socket, tighten the nut until metal-to-metal contact occurs at the bolt pads. Verify that the pipe marks indicate full insertion into the coupling and that the oval neck of the bolt seats properly in the bolt hole. Refer to the “Style P07 Helpful Information” table below and the “Impact Wrench Usage Guidelines” section on page 10.

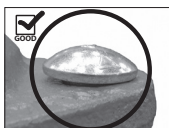

OVAL NECK OF BOLT SEATED PROPERLY



OVAL NECK OF BOLT NOT SEATED PROPERLY

STYLE P07 HELPFUL INFORMATION

Nominal inches/DN	Actual Outside Diameter inches/mm	Bolt Size inches/Metric	Deep-Well Socket Size inches/mm
1/2 – 1 1/2 DN15 – DN40	0.840 21.3	3/8 M10	1 1/16 17
2 DN50	2.375 60.3	7/16 M11	1 1/16 17

Instructions continue on the following page

WARNING

- Visual inspection of each joint is required.
- Improperly assembled joints shall be corrected before the system is tested or placed into service.
- Any components that exhibit physical damage due to improper assembly shall be replaced.

Failure to follow these instructions could cause joint failure, resulting in death or serious personal injury and property damage.

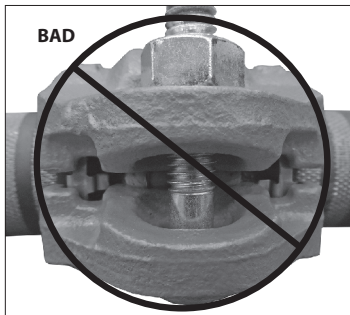
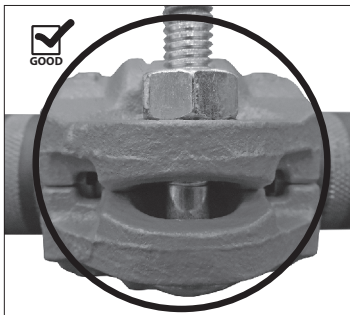

3. Visually inspect the bolt pads at each joint to verify that metal-to-metal contact is achieved in accordance with step 2.

Style P08 QuickVic™ SD Installation-Ready™ Slip Coupling for Plain-End Carbon Steel Pipe

Installation Instructions

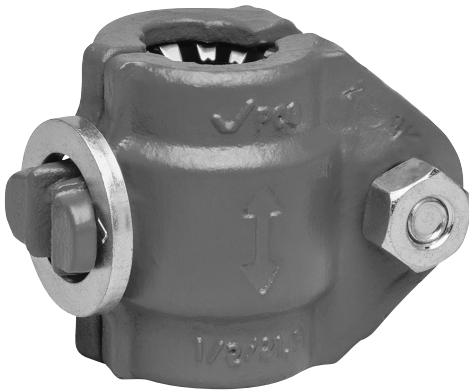

Style P08 – QuickVic™ SD Installation-Ready™ Slip Coupling for Plain-End Carbon Steel Pipe

⚠ WARNING



- Read and understand all instructions before attempting to install, remove, adjust, or maintain any Victaulic piping products.
 - Always depressurize and drain the piping system before attempting to install, remove, adjust, or maintain any Victaulic piping products.
 - Wear safety glasses, hardhat, and foot protection.
- Failure to follow these instructions could result in death or serious personal injury and property damage.

Verify that the following instructions in the “General Information” section have been followed:

- Pipe Preparation Requirements**
- Minimum Pipe Nipple Length Requirements**
- Pipe Marking Requirements**
- Lubrication Requirements**

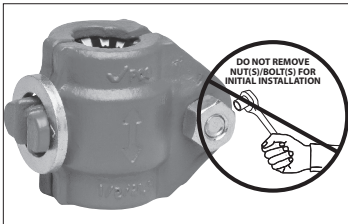

DO NOT DISASSEMBLE THE STYLE P08 FOR THE INITIAL INSTALLATION: The Style P08 is designed so that the installer does not need to remove the bolt(s), nut(s), or linkage for installation. This facilitates assembly by allowing the installer to directly install the Style P08 onto marked plain-end pipe.

⚠ WARNING



- Never leave a Style P08 partially assembled. **ALWAYS TIGHTEN THE HARDWARE IMMEDIATELY.** A partially assembled Style P08 poses a drop or fall hazard during installation and a burst hazard during testing.
 - Keep hands away from the opening of the Style P08 when attempting to insert marked plain-end pipe. Retainer teeth are sharp and may cause injury.
- Failure to follow these instructions could result in serious personal injury and property damage.

½ – 1 ¼-inch/DN15 – DN32 Sizes (One Bolt)



1 ½ – 2-inch/DN40 – DN50 Sizes (Two Bolts)



1. PUSH STYLE P08 OVER PIPE END: Apply an additional coat of Victaulic Lubricant or silicone lubricant to the face of the pipe. Push the Style P08 completely over one marked plain-end pipe.

½ – 1 ¼-inch/DN15 – DN32 Sizes (One Bolt)



1 ½ – 2-inch/DN40 – DN50 Sizes (Two Bolts)

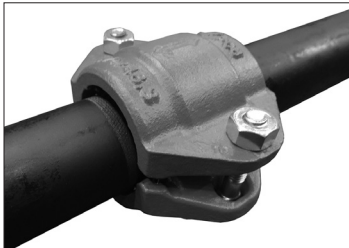

2. ASSEMBLE JOINT: Align and bring the second marked plain-end pipe into position. Pull the Style P08 onto the other pipe end and verify that the pipe marks on both sides indicate full insertion into the coupling, as shown. Refer to the “Pipe Insertion Requirements” section on pages 8 – 9.

Instructions continue on the following page

! WARNING

- For ½ – 1 ¼-inch/DN15 – DN32 sizes the nut shall be tightened until metal-to-metal contact occurs at the bolt pads.
- For 1 ½ – 2-inch/DN40 – DN50 sizes, the nuts shall be tightened evenly by alternating sides until metal-to-metal contact occurs at the bolt pads.

Failure to follow instructions for tightening hardware could result in:

- Personal injury or death
- Bolt damage or fracture
- Damaged or broken bolt pads or fractures to housings
- Joint leakage and property damage

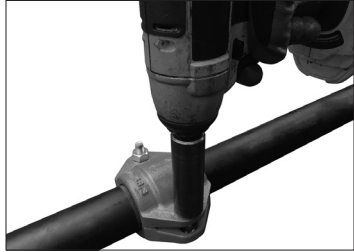

3a. FOR ½ – 1 ¼-INCH/DN15 – DN32 SIZES: Using an impact wrench or standard socket wrench with a deep-well socket, tighten the nut until metal-to-metal contact occurs at the bolt pads. Verify that the pipe marks indicate full insertion into the coupling and that the oval neck of the bolt seats properly in the bolt hole.

3b. FOR 1 ½ – 2-INCH/DN40 – DN50 SIZES: Using an impact wrench or standard socket wrench with a deep-well socket, tighten the nuts evenly by alternating sides until metal-to-metal contact occurs at the bolt pads. Verify that the pipe marks indicate full insertion into the coupling and that the oval neck of each bolt seats properly in the bolt hole. **NOTE:** It is important to tighten the nuts evenly to prevent gasket pinching.

3c. Refer to the “Style P08 Helpful Information” table below and the “Impact Wrench Usage Guidelines” section on page 10.



OVAL NECK OF BOLT SEATED PROPERLY



OVAL NECK OF BOLT NOT SEATED PROPERLY

STYLE P08 HELPFUL INFORMATION

Nominal inches/DN	Actual Outside Diameter inches/mm	Bolt Size inches/Metric	Deep-Well Socket Size inches/mm
½ – 1 ½ DN15 – DN40	0.840 21.3	¾ M10	1 1/16 17
2 DN50	2.375 60.3	7/16 M11	1 1/16 17

WARNING

- Visual inspection of each joint is required.
- Improperly assembled joints shall be corrected before the system is tested or placed into service.
- Any components that exhibit physical damage due to improper assembly shall be replaced.

Failure to follow these instructions could cause joint failure, resulting in death or serious personal injury and property damage.

½ – 1 ¼-inch/DN15 – DN32 Sizes (One Bolt)

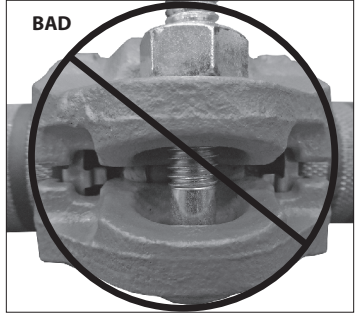
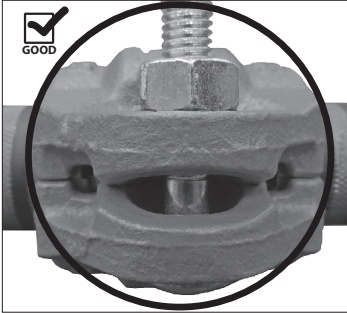

1 ½ – 2-inch/DN40 – DN50 Sizes (Two Bolts)

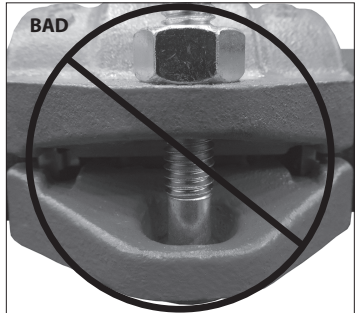
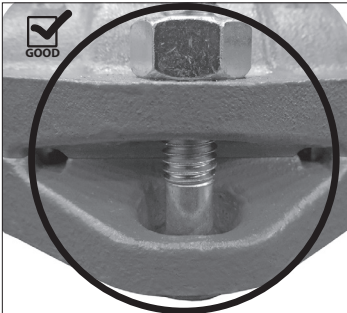

4. Visually inspect the bolt pads at each joint to verify that metal-to-metal contact is achieved in accordance with step 3a or 3b.



I-P100_38

Style P50 QuickVic™ SD Installation-Ready™ Reducing Coupling for Plain-End Carbon Steel Pipe

Installation Instructions

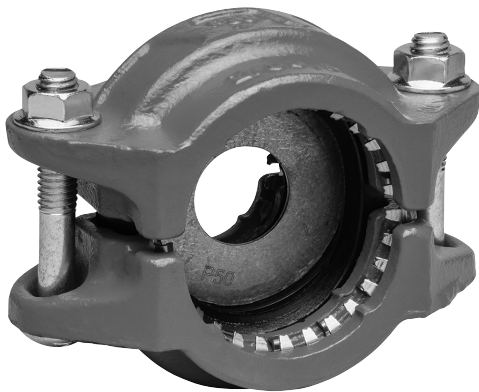

Style P50 – QuickVic™ SD Installation-Ready™ Reducing Coupling for Plain-End Carbon Steel Pipe

⚠ WARNING



- Read and understand all instructions before attempting to install, remove, adjust, or maintain any Victaulic piping products.
 - Always depressurize and drain the piping system before attempting to install, remove, adjust, or maintain any Victaulic piping products.
 - Wear safety glasses, hardhat, and foot protection.
- Failure to follow these instructions could result in death or serious personal injury and property damage.

Verify that the following instructions in the “General Information” section have been followed:

- Pipe Preparation Requirements
- Minimum Pipe Nipple Length Requirements
- Pipe Marking Requirements
- Lubrication Requirements

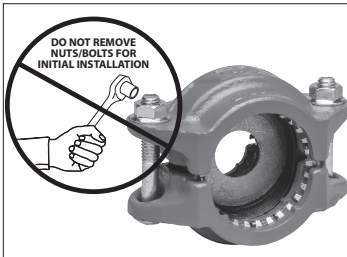

DO NOT DISASSEMBLE THE STYLE P50 FOR INITIAL INSTALLATION: The Style P50 is designed so that the installer does not need to remove the bolts and nuts for installation. This facilitates assembly by allowing the installer to directly install the Style P50 onto marked plain-end pipe.

⚠ WARNING



- Never leave a Style P50 partially assembled. **ALWAYS TIGHTEN THE HARDWARE IMMEDIATELY.** A partially assembled Style P50 poses a drop or fall hazard during installation and a burst hazard during testing.
 - Keep hands away from the opening of the Style P50 when attempting to insert marked plain-end pipe. Retainer teeth are sharp and may cause injury.
- Failure to follow these instructions could result in serious personal injury and property damage.

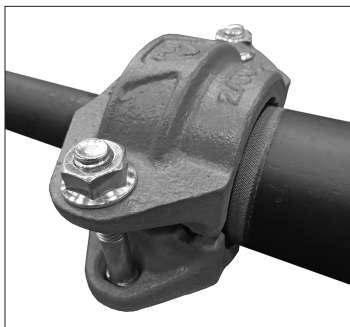
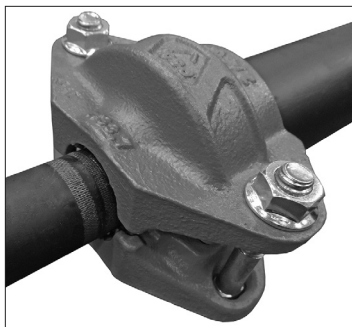

1. ASSEMBLE JOINT: Assemble the joint by inserting a marked plain-end pipe of each size into the corresponding opening of the Style P50. Verify that the pipe is inserted until the mark indicates full insertion into the coupling, as shown. Refer to the “Pipe Insertion Requirements” section on pages 8 – 9.

⚠ WARNING

- The nuts shall be tightened evenly by alternating sides until metal-to-metal contact occurs at the bolt pads.
- Failure to follow instructions for tightening hardware could result in:
- Personal injury or death
 - Bolt damage or fracture
 - Damaged or broken bolt pads or fractures to housings
 - Joint leakage and property damage

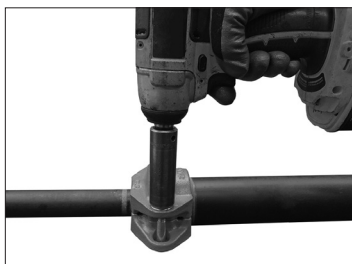

2. TIGHTEN NUTS: Using an impact wrench or standard socket wrench with a deep-well socket, tighten the nuts evenly by alternating sides until metal-to-metal contact occurs at the bolt pads. Verify that the pipe marks indicate full insertion into the coupling and that the oval neck of each bolt seats properly in the bolt hole. **NOTE:** It is important to tighten the nuts evenly to prevent gasket pinching. Refer to the “Style P50 Helpful Information” table below and the “Impact Wrench Usage Guidelines” section on page 10.

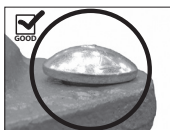

OVAL NECK OF BOLT SEATED PROPERLY



OVAL NECK OF BOLT NOT SEATED PROPERLY

STYLE P50 HELPFUL INFORMATION

Nominal inches/DN	Actual Outside Diameter inches/mm	Bolt Size inches/Metric	Deep-Well Socket Size inches/mm
½ – 1½ DN15 – DN40	0.840 21.3	¾ M10	1¼ 17
2 DN50	2.375 60.3	7/16 M11	1¼ 17

WARNING

- Visual inspection of each joint is required.
- Improperly assembled joints shall be corrected before the system is tested or placed into service.
- Any components that exhibit physical damage due to improper assembly shall be replaced.

Failure to follow these instructions could cause joint failure, resulting in death or serious personal injury and property damage.

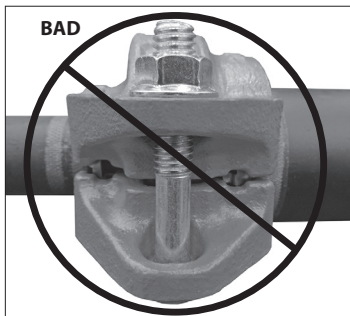
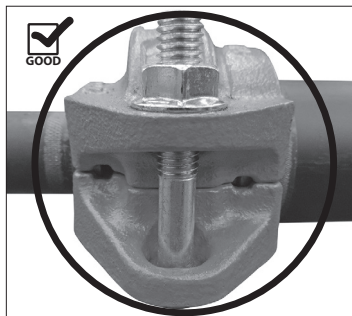

3. Visually inspect the bolt pads at each joint to verify that metal-to-metal contact is achieved in accordance with step 2.

No. P47 (Straight) and No. P97 (90° Elbow) Dielectric Adapters (Plain End x Sweat)

Installation Instructions



NO. P47



NO. P97

- No. P47** – Straight Dielectric Adapter (Plain End x Sweat)
No. P97 – 90° Elbow Dielectric Adapter (Plain End x Sweat)

! WARNING



- Read and understand all instructions before attempting to install, remove, adjust, or maintain any Victaulic piping products.
 - Always depressurize and drain the piping system before attempting to install, remove, adjust, or maintain any Victaulic piping products.
 - Wear safety glasses, hardhat, and foot protection.
- Failure to follow these instructions could result in death or serious personal injury and property damage.

Instructions for Sweating to “COPPER” Side of No. P47 or P97 Dielectric Adapters

The “COPPER” side of No. P47 and P97 Dielectric Adapters shall be sweat to the copper tubing and allowed to cool to ambient temperature before making the connection to the Victaulic Plain-End, Installation-Ready™ System Product for carbon steel pipe. Refer to the table below for the minimum sweat depths.

Size		Dimensions – inches/mm
Nominal inches/DN	Actual Outside Diameter inches/mm	“G” Minimum Sweat Depth
½ DN15	0.840 21.3	0.50 13
¾ DN20	1.050 26.9	0.75 19
1 DN25	1.315 33.7	0.91 23
1 ¼ DN32	1.660 42.4	0.97 25

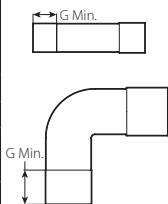

Instructions for Connecting to “STEEL” Side of No. P47 or P97 Dielectric Adapters



The instructions for the applicable coupling or fitting shall be followed for proper installation on the “STEEL” side of No. P47 and P97 Dielectric Adapters. **NOTE:** Any of the couplings and fittings featured in this handbook can be used to connect to the “STEEL” side of the No. P47 and P97 Dielectric Adapters. The dielectric adapter shall be inserted into the coupling or fitting up to the insertion depth indicator, as shown above.

Series P89 Ball Valve

Installation and Handle Extension Kit Instructions



! WARNING



- Read and understand all instructions before attempting to install, remove, adjust, or maintain any Victaulic piping products.
 - Always depressurize and drain the piping system before attempting to install, remove, adjust, or maintain any Victaulic piping products.
 - Wear safety glasses, hardhat, and foot protection.
- Failure to follow these instructions could result in death or serious personal injury and property damage.

Installation of the Ball Valve

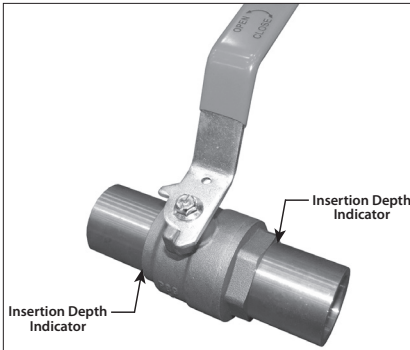

If changeout of the Series P89 Ball Valve is anticipated, it is recommended that the valve be installed with two Style P08 Slip Couplings, in accordance with the instructions on pages 33 – 38 of this handbook. However, any of the couplings and fittings featured in this handbook can be used to connect to the Series P89 Ball Valve. The ends of the Series P89 Ball Valve shall be inserted into the coupling or fitting to within $\frac{1}{8}$ inch/ 3.2 mm from the insertion depth indicator, as shown to the left.

Installation of the Handle Extension Kit

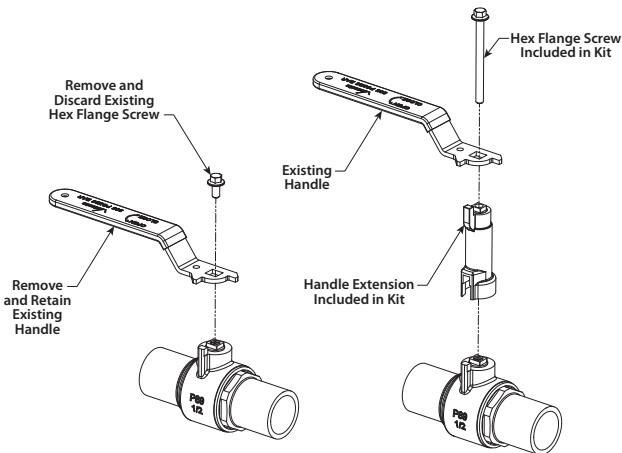

1. Remove and discard the existing hex flange screw, then remove and retain the existing handle, as shown above.

2. Install the handle extension (provided in kit) onto the ball valve body in the orientation shown above. Place the handle onto the handle extension, then use the hex flange screw (provided in kit) to retain the handle and handle extension on the ball valve body.

QuickVic™ SD Installation-Ready™ System Products

Reuse Instructions

QuickVic™ SD Installation-Ready™ System Products Reuse Instructions

WARNING



- Read and understand all instructions before attempting to install, remove, adjust, or maintain any Victaulic piping products.
 - Always depressurize and drain the piping system before attempting to install, remove, adjust, or maintain any Victaulic piping products.
 - Wear safety glasses, hardhat, and foot protection.
- Failure to follow these instructions could result in death or serious personal injury and property damage.

REMOVAL OF A COUPLING OR FITTING FROM THE PIPING SYSTEM

WARNING



- Always depressurize and drain the piping system before attempting to install, remove, adjust, or maintain any Victaulic piping products.
- Failure to follow this instruction could result in death or serious personal injury and property damage.

NOTICE

- QuickVic™ SD Installation-Ready™ System Products do not need to be fully disassembled for removal from the pipe ends. However, if a coupling or fitting is fully disassembled during maintenance or for any other reason, refer to the “Full Inspection of a Gasket Removed from a Coupling or Fitting” and “Full Inspection of Retainers Removed from a Coupling or Fitting” sections on the following pages.

1. Verify that the system is depressurized and drained completely before attempting to remove any couplings or fittings from the pipe.

2a. FOR NO. P10 90° ELBOWS: Loosen the nuts only on the outside and inside locations of the fitting end where the first pipe is to be removed (nuts should be backed off no further than flush with the end of the bolts). Remove the pipe from the loosened side. While supporting the fitting, loosen the nut at the other outside location. Carefully remove the fitting from the pipe.

2b. FOR NO. P20 STRAIGHT TEES: Loosen the nuts only along the branch side of the fitting (nuts should be backed off no further than flush with the end of the bolts). Remove the pipe from the loosened branch side. While supporting the fitting, loosen the nuts along the run side of the fitting. Carefully remove the fitting from the pipe.

2c. FOR STYLE P07 COUPLINGS, STYLE P08 SLIP COUPLINGS, AND STYLE P50 REDUCING COUPLINGS: Be prepared to support the coupling. Loosen the nut(s) until backed off no further than flush with the end of the bolt(s). Carefully remove the coupling from the pipe.

3. Follow the “Inspection of Gasket and Retainers Still Installed Within a Coupling or Fitting” and “Inspection of Pipe Ends” sections on the following pages.



INSPECTION OF GASKET AND RETAINERS STILL INSTALLED WITHIN A COUPLING OR FITTING

CAUTION

- If you suspect that any damage or wear has occurred to the gasket and retainers, the coupling or fitting shall be fully disassembled so that the affected components can be replaced.

Failure to follow this instruction will result in joint leakage and property damage.

Example of a Damaged Gasket

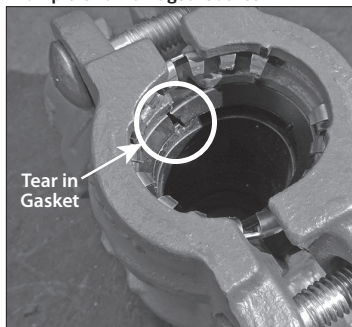

1. Inspect the gasket for any damage or wear (tears in gasket lips, deformities in gasket lips, or pinched sections at the bolt pad locations). If any gasket damage or wear is present, fully disassemble the coupling or fitting so that the gasket can be replaced with a new Victaulic-supplied gasket of the same material grade and style number.

If in doubt, always fully disassemble the coupling or fitting to perform a more thorough inspection of the gasket, in accordance with the “Full Inspection of a Gasket Removed from a Coupling or Fitting” section.

Example of a Damaged Retainer

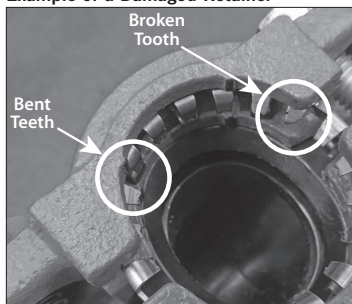

2. Inspect the retainers for any damage (broken, bent, or missing teeth or deformities in the shape of the retainers). If any retainer damage is present, fully disassemble the coupling or fitting so that the retainers can be replaced with new Victaulic-supplied retainers.

If in doubt, always fully disassemble the coupling or fitting to perform a more thorough inspection of the retainers, in accordance with the “Full Inspection of Retainers Removed from a Coupling or Fitting” section.

3a. After inspection of the gasket and retainers, if it is determined that the coupling or fitting **CAN** be reused in its current condition, follow the applicable installation section of this handbook. **NOTE:** Following the first assembly of the product on pipe, the functionality of the patented “Leak-if-Not-Tightened” technology may not operate as described in the “General Information” section.

3b. After inspection of the gasket and retainers, if it is determined that the coupling or fitting **CANNOT** be reused in its current condition and requires full disassembly, refer to the “Full Inspection of a Gasket Removed from a Coupling or Fitting” and “Full Inspection of Retainers Removed from a Coupling or Fitting” sections on the following pages.

INSPECTION OF PIPE ENDS

Perform a thorough inspection of the pipe ends that are to be reused.

1. The pipe OD shall not contain burrs, sharp edges, raised weld beads, axial score marks, scratches, or indentations a minimum of 1 ½ inches/38 mm back from the pipe end. All oil, grease, loose paint, dirt, and cutting particles shall be removed.
2. Verify that the insertion depth mark(s) on each pipe end are still clearly visible (particularly for pipe ends that were marked originally with a paint pen).

If there are any doubts concerning the condition of the pipe ends, always cut off the end and re-mark the pipe. Refer to the “General Information” section for complete pipe preparation requirements.

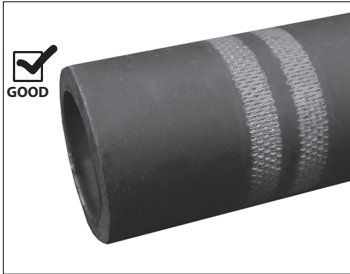

EXAMPLE OF PIPE END IN GOOD CONDITION THAT CAN BE REUSED (NO DAMAGE AND CLEAR INSERTION DEPTH MARKS)

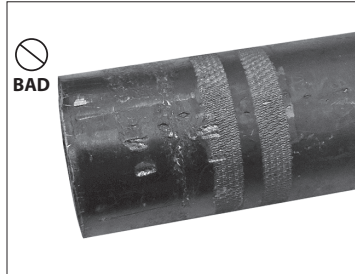

EXAMPLE OF PIPE END IN BAD CONDITION THAT SHALL NOT BE REUSED (IMPROPER CUT, SCRATCHES ON GASKET SEALING SURFACE, DEFORMITIES)

FULL INSPECTION OF GASKET REMOVED FROM A COUPLING OR FITTING

Perform a thorough inspection of the full gasket prior to reassembly of a coupling or fitting. **If there are any doubts concerning the condition of the gasket, always replace it with a new Victaulic-supplied gasket of the same material grade and style number.**

NOTE: In cases where both the gaskets and retainers will be replaced with new Victaulic-supplied gaskets and retainers, the functionality of the patented “Leak-if-Not-Tightened” technology will operate as described in the “General Information” section.

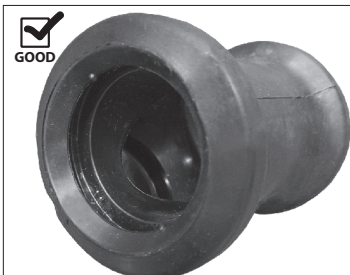

EXAMPLE OF GASKET IN GOOD CONDITION THAT CAN BE REUSED (NO DAMAGE, WEAR, OR DEFORMITIES)

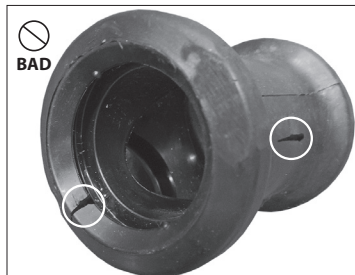

EXAMPLE OF GASKET IN BAD CONDITION THAT SHALL NOT BE REUSED (CONTAINS DAMAGE)

FULL INSPECTION OF RETAINERS REMOVED FROM A COUPLING OR FITTING

Perform a thorough inspection of each retainer prior to reassembly of a coupling or fitting. **If there are any doubts concerning the condition of the retainers, always replace them with new Victaulic-supplied retainers of the same size. Refer to the “Number of Teeth Per Retainer” table below as a second means of identifying that the correct size retainer is being used for the product size. NOTE:** In cases where both the gaskets and retainers will be replaced with new Victaulic-supplied gaskets and retainers, the functionality of the patented “Leak-if-Not-Tightened” technology will operate as described in the “General Information” section.

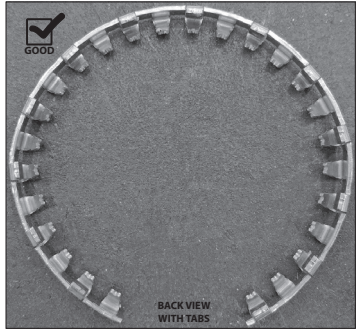
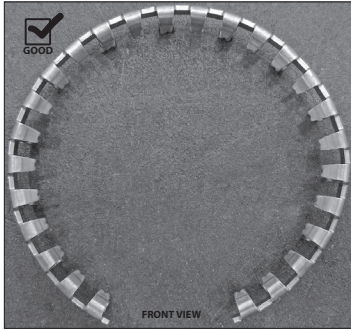

EXAMPLES OF RETAINERS IN GOOD CONDITION THAT CAN BE REUSED (TEETH ARE UNIFORM, NO DAMAGE TO TEETH, NO DEFORMITIES IN SHAPE)

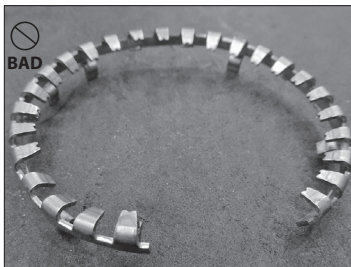

EXAMPLE OF RETAINER IN BAD CONDITION THAT SHALL NOT BE REUSED (TEETH ARE BENT, SHAPE IS DEFORMED)

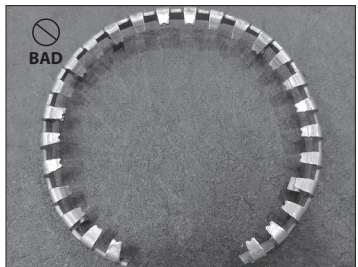

EXAMPLE OF RETAINER IN BAD CONDITION THAT SHALL NOT BE REUSED (TEETH ARE BENT AND NOT UNIFORM)

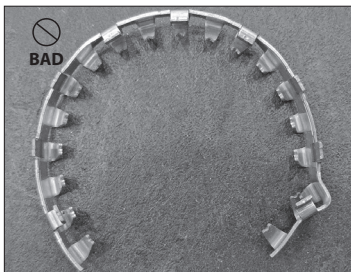

EXAMPLE OF RETAINER IN BAD CONDITION THAT SHALL NOT BE REUSED (COMPRESSED AT BOLT PAD LOCATION AS A RESULT OF INCORRECT SIZE BEING USED)

Number of Teeth Per Retainer

Size		Number of Teeth
Nominal inches/DN	Actual Outside Diameter inches/mm	
1/2 DN15	0.840 21.3	11
3/4 DN20	1.050 26.9	13
1 DN25	1.315 33.7	16
1 1/4 DN32	1.660 42.4	19
1 1/2 DN40	1.900 48.3	21
2 DN50	2.375 60.3	26

REASSEMBLY OF A NO. P10 ELBOW OR NO. P20 STRAIGHT TEE

NOTICE

- The following steps shall be completed if a coupling or fitting is fully disassembled during removal from the pipe ends or to replace the gasket or retainers.
- Only genuine Victaulic replacement parts shall be used for reassembly of a No. P10 Elbow or No. P20 Straight Tee.
- The coupling or fitting shall be reassembled, as shown in the steps below, before attempting to reinstall the product onto pipe ends.

! CAUTION

- A thin coat of Victaulic Lubricant or silicone lubricant shall be used to prevent the gasket from pinching, rolling, or tearing during reassembly. Failure to use a compatible lubricant will cause gasket damage, resulting in joint leakage and property damage.



1. LUBRICATE CORRECT SIZE GASKET: Apply a thin coat of Victaulic Lubricant or silicone lubricant to the correct size gasket's sealing lips and exterior portion outside the sealing lips, as shown.

NOTE: For gaskets that are being reused, it is normal for the gasket to have a hazy white appearance after it has been in service.

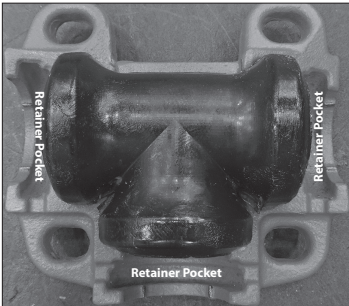

2. INSTALL GASKET INTO FIRST FITTING HOUSING: Install the gasket into one of the housings. Verify that the ends of the gasket are seated fully in the housing's pockets, as shown.

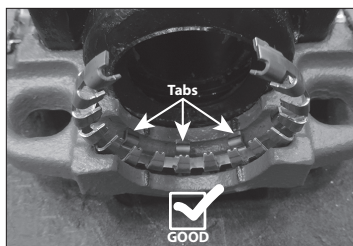

3. INSTALL CORRECT SIZE RETAINERS INTO HOUSING: Install the correct size retainer into each retainer pocket of the housing (refer to the “Number of Teeth Per Retainer” table on page 51). Verify that the tabs are facing toward the gasket and that the gap of each retainer is facing away from the bolt pad locations, as shown.



4. INSTALL SECOND FITTING HOUSING:

Install the second fitting housing. Verify that the ends of the gasket are seated in the housings' pockets and that the retainers are seated fully in the housings' retainer pockets.

5. INSTALL BOLTS AND NUTS: Install the bolts, and thread a nut onto each bolt.

NOTE: Verify that the oval neck of each bolt seats properly in the bolt hole. DO NOT tighten the nuts completely. The bolt pads need to be set at a gap for reinstallation of the fitting. Two to three full bolt threads, exposed above each nut, will provide the proper gap.

6. Follow all steps of the No. P10 or No. P20 installation section of this handbook to reinstall the fitting.

REASSEMBLY OF A STYLE P07 COUPLING OR STYLE P08 SLIP COUPLING

NOTICE

- The following steps shall be completed if a coupling or fitting is fully disassembled during removal from the pipe ends or to replace the gasket or retainers.
- Only genuine Victaulic replacement parts shall be used for reassembly of a Style P07 Coupling or Style P08 Slip Coupling.
- The coupling or fitting shall be reassembled, as shown in the steps below, before attempting to reinstall the product onto pipe ends.

! CAUTION

- A thin coat of Victaulic Lubricant or silicone lubricant shall be used to prevent the gasket from pinching, rolling, or tearing during reassembly. Failure to use a compatible lubricant will cause gasket damage, resulting in joint leakage and property damage.



1. LUBRICATE GASKET: Apply a thin coat of Victaulic Lubricant or silicone lubricant to the gasket's sealing lips and exterior, as shown. For gaskets that are being reused, it is normal for the gasket to have a hazy white appearance after it has been in service.

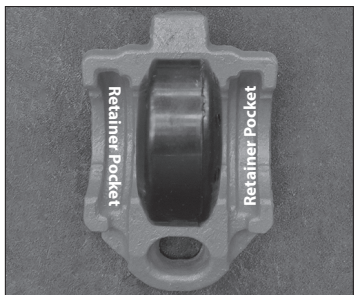

2. INSTALL GASKET INTO FIRST COUPLING HOUSING: Install the gasket into one of the housings. Verify that the gasket is seated fully in the housing's pocket.

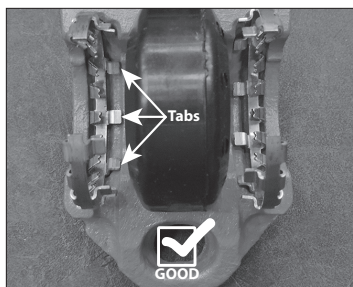

3. INSTALL RETAINERS INTO HOUSING: Install the correct size retainer into each retainer pocket of the housing (refer to the “Number of Teeth Per Retainer” table on page 51). Verify that the tabs are facing toward the gasket and that the gap of each retainer is facing away from the bolt pad locations, as shown.



4a. FOR ALL SIZES OF STYLE P07 COUPLINGS AND ½ – 1 ¼-INCH/DN15 – DN32 STYLE P08 SLIP COUPLINGS INSTALL SECOND COUPLING HOUSING AND LINKAGE: Install the second coupling housing. Verify that the gasket is seated in the housings’ pockets and that the retainers are seated fully in the housings’ retainer pockets. Install the linkage onto the housings, as shown above.

4b. INSTALL BOLT AND NUT: Install the bolt, and thread a nut onto the bolt. **NOTE:** Verify that the oval neck of the bolt seats properly in the bolt hole. DO NOT tighten the nut completely. The bolt pads need to be set at a gap for reinstallation of the coupling. The nut should be flush with the top of the bolt to provide the proper gap.



4c. FOR 1 ½ – 2-INCH/DN40 – DN50 STYLE P08 SLIP COUPLINGS INSTALL SECOND COUPLING HOUSING: Install the second coupling housing. Verify that the gasket is seated in the housings’ pockets and that the retainers are engaged with the housings’ retainer pockets.

4d. INSTALL BOLTS AND NUTS: Install the bolts, and thread a nut onto the bolts. **NOTE:** Verify that the oval neck of each bolt seats properly in the bolt holes. DO NOT tighten the nuts completely. The bolt pads need to be set at a gap for reinstallation of the coupling. Two to three full bolt threads, exposed above the nuts, will provide the proper gap.

5. Follow all steps of the Style P07 or Style P08 installation section of this handbook to reinstall the coupling.

REASSEMBLY OF A STYLE P50 REDUCING COUPLING

NOTICE

- The following steps shall be completed if a coupling or fitting is fully disassembled during removal from the pipe ends or to replace the gasket or retainers.
- Only genuine Victaulic replacement parts shall be used for reassembly of a Style P50 Reducing Coupling.
- The coupling or fitting shall be reassembled, as shown in the steps below, before attempting to reinstall the product onto pipe ends.

! CAUTION

- A thin coat of Victaulic Lubricant or silicone lubricant shall be used to prevent the gasket from pinching, rolling, or tearing during reassembly. Failure to use a compatible lubricant will cause gasket damage, resulting in joint leakage and property damage.

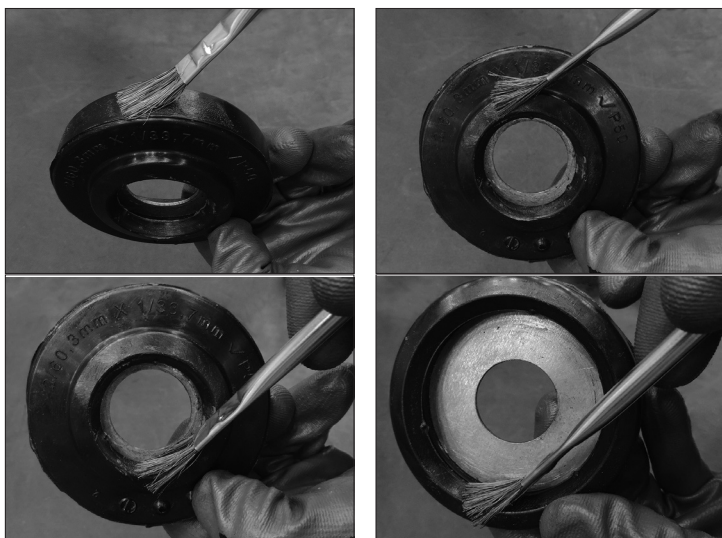

1. LUBRICATE GASKET: Apply a thin coat of Victaulic Lubricant or silicone lubricant to the four surfaces of the gasket shown above. For gaskets that are being reused, it is normal for the gasket to have a hazy white appearance after it has been in service.

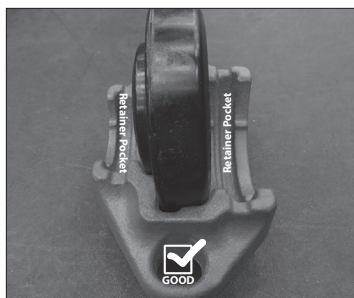

2. INSTALL GASKET INTO FIRST COUPLING HOUSING: Install the gasket into one of the housings. Verify that the smaller opening of the gasket is facing toward the smaller opening of the housing, as shown above, and that the gasket is seated fully in the housing's pocket. **NOTE:** The gasket design for 1 ¼ x ¾-inch/DN32 x DN20 and larger sizes is shown above.

NOTICE

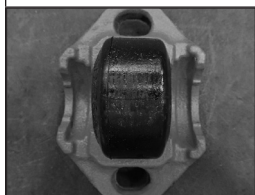

- Gaskets for the ¾ x ½-inch/DN20 x DN15 and 1 x ¾-inch/DN25 x DN20 configurations do not contain a metal insert or the defined section for the smaller opening, as shown above. Take additional care to verify that the smaller side of the gasket is facing toward the smaller opening of the housing, as shown to the left.

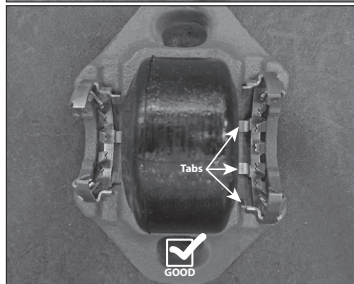
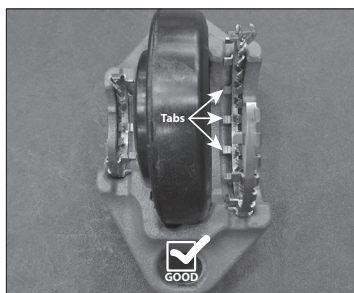

3. INSTALL RETAINERS INTO HOUSING: Install the correct size retainer into each corresponding retainer pocket of the housing (refer to the “Number of Teeth Per Retainer” table on page 51). Verify that the tabs are facing toward the gasket and that the gap of each retainer is facing away from the bolt pad locations, as shown. **NOTE:** Due to the similarity in retainers for the ¾ x ½-inch/DN20 x DN15 and 1 x ¾-inch/DN25 x DN20 configurations, it is especially important to reference the “Number of Teeth Per Retainer” table on page 51 as a verification that the correct size retainers are being used.



4. INSTALL SECOND FITTING HOUSING:

Install the second fitting housing. Verify that the gasket is seated in the housings' pockets and that the retainers are seated fully in the housings' retainer pockets.

5. INSTALL BOLTS AND NUTS: Install the bolts, and thread a nut onto each bolt.

NOTE: Verify that the oval neck of each bolt seats properly in the bolt hole. **DO NOT** tighten the nuts completely. The bolt pads need to be set at a gap for reinstallation of the fitting. Two to three full bolt threads, exposed above each nut, will provide the proper gap.

6. Follow all steps of the Style P50 installation section of this handbook to reinstall the coupling.

Product Data

The following information contains center-to-end, end-to-end, take-out, and similar overall dimensions for QuickVic™ SD Installation-Ready™ System products for carbon steel pipe.

NOTICE

- **Always refer to the current Victaulic publication 34.01 for the most up-to-date dimensional information and for products not listed in this section. Publication 34.01 can be downloaded at victaulic.com.**

FITTINGS

No. P10 – 90° Elbow

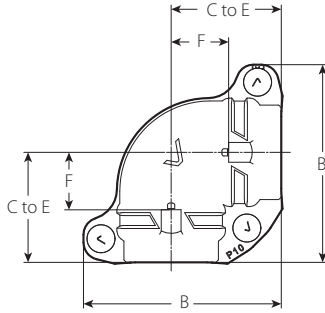

Size		Dimensions – inches/mm		
Nominal inches/DN	Actual Outside Diameter inches/mm	F Takeout	C to E	B
½ DN15	0.840 21.3	0.88 22	2.13 54	3.88 99
¾ DN20	1.050 26.9	1.00 25	2.13 54	4.00 102
1 DN25	1.315 33.7	1.13 29	2.25 57	4.38 111
1 ¼ DN32	1.660 42.4	1.38 35	2.50 64	4.75 121
1 ½ DN40	1.900 48.3	1.38 35	3.00 76	5.38 137
2 DN50	2.375 60.3	1.63 41	3.25 83	5.88 149



Always refer to the current Victaulic publication 34.01 for the most up-to-date dimensional information. Publication 34.01 can be downloaded at victaulic.com.



FITTINGS

No. P20 – Tee

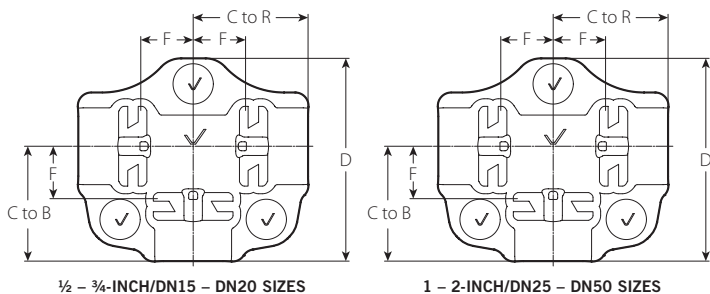

Size		Dimensions – inches/mm			
Nominal inches/DN	Actual Outside Diameter inches/mm	F Takeout	C to B	C to R	D
1/2 DN15	0.840 21.3	0.88 22	2.13 54	2.13 54	3.63 92
3/4 DN20	1.050 26.9	1.00 25	2.25 57	2.25 57	3.88 98
1 DN25	1.315 33.7	1.13 29	2.25 57	2.25 57	4.38 111
1 1/4 DN32	1.660 42.4	1.38 35	2.50 64	2.50 64	4.75 121
1 1/2 DN40	1.900 48.3	1.38 35	3.00 76	3.00 76	5.38 137
2 DN50	2.375 60.3	1.63 41	3.25 83	3.25 83	5.88 149



Always refer to the current Victaulic publication 34.01 for the most up-to-date dimensional information. Publication 34.01 can be downloaded at victaulic.com.



COUPLINGS

Style P07 – Coupling

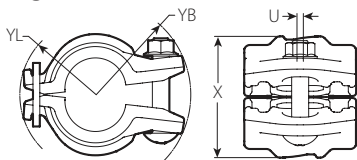

PRE-ASSEMBLED

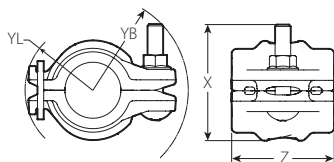

ASSEMBLED

Size		Dimensions – inches/mm							
Nominal inches/DN	Actual Outside Diameter inches/mm	Pre-Assembled			Assembled				
		Y _L	Y _B	X	Y _L	Y _B	X	U	Z
½ DN15	0.840 21.3	1.50 38	2.00 51	2.38 60	1.50 38	2.13 54	2.50 64	0.14 4	2.50 64
¾ DN20	1.050 26.9	1.63 41	2.13 54	2.38 60	1.50 38	2.25 57	2.63 67	0.14 4	2.50 64
1 DN25	1.315 33.7	1.75 44	2.25 57	2.75 70	1.75 44	2.25 57	2.75 70	0.14 4	2.50 64
1¼ DN32	1.660 42.4	1.88 48	2.38 60	3.00 76	1.88 48	2.50 64	2.88 73	0.14 4	2.50 64
1½ DN40	1.900 48.3	2.13 54	2.63 67	3.38 86	2.88 73	3.50 89	3.50 89	0.14 4	3.25 83
2 DN50	2.375 60.3	2.38 60	3.00 76	3.88 99	3.25 83	3.88 99	3.88 99	0.14 4	3.25 83



Always refer to the current Victaulic publication 34.01 for the most up-to-date dimensional information. Publication 34.01 can be downloaded at victaulic.com.

COUPLINGS

Style P08 – Slip Coupling

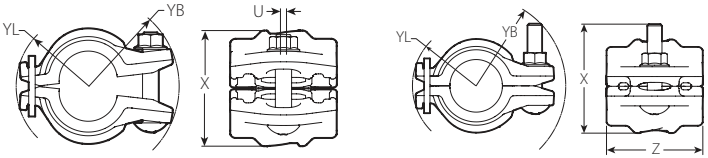

PRE-ASSEMBLED ASSEMBLED
 ½ – 1¼-INCH/DN15 – DN32 SIZES

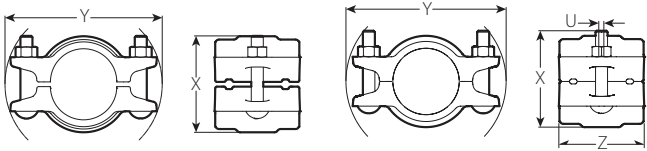

PRE-ASSEMBLED ASSEMBLED
 1½ – 2-INCH/DN40 – DN50 SIZES

Size		Dimensions – inches/mm									
Nominal inches/DN	Actual Outside Diameter inches/mm	Pre-Assembled				Assembled					
		Y _L	Y _B	Y	X	Y _L	Y _B	Y	X	U	Z
½ DN15	0.840 21.3	1.50 38	2.00 51	–	2.38 60	1.50 38	2.13 54	–	2.50 64	0.00 0	2.38 60
¾ DN20	1.050 26.9	1.63 41	2.13 54	–	2.38 60	1.50 38	2.25 57	–	2.63 67	0.00 0	2.38 60
1 DN25	1.315 33.7	1.75 44	2.25 57	–	2.75 70	1.75 44	2.25 57	–	2.75 70	0.00 0	2.38 60
1¼ DN32	1.660 42.4	1.88 48	2.38 60	–	3.00 76	1.88 48	2.50 64	–	2.88 73	0.00 0	2.38 60
1½ DN40	1.900 48.3	–	–	4.92 125	3.14 80	–	–	5.03 128	2.91 74	0.00 0	3.07 78
2 DN50	2.375 60.3	–	–	5.74 146	3.52 89	–	–	5.84 148	3.52 89	0.00 0	3.11 79



Always refer to the current Victaulic publication 34.01 for the most up-to-date dimensional information. Publication 34.01 can be downloaded at victaulic.com.



COUPLINGS

Style P50 – Reducing Coupling

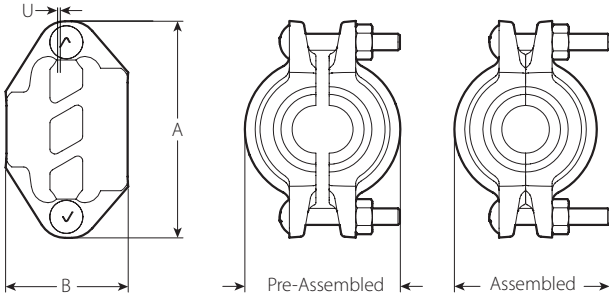

Size		Dimensions – inches/mm				
Nominal inches/DN	Actual Outside Diameter inches/mm	A	B	Pre-Assembled	Assembled	U
$\frac{3}{4}$ x $\frac{1}{2}$ DN20 DN15	1.050 x 0.840 26.9 x 21.3	3.65 93	2.52 64	2.98 76	2.98 76	0.15 4
1 x $\frac{3}{4}$ DN25 DN20	1.315 x 1.050 33.7 x 26.9	3.96 101	2.53 64	3.11 79	3.11 79	0.20 5
$1\frac{1}{4}$ x $\frac{3}{4}$ DN32 DN20	1.660 x 1.050 42.4 x 26.9	4.76 121	2.41 61	3.24 82	3.24 82	0.06 1.5
1 DN25	1.315 33.7	4.55 116	2.39 61	3.38 86	3.38 86	0.06 1.5
$1\frac{1}{2}$ x $\frac{3}{4}$ DN40 DN20	1.900 x 1.050 48.3 x 26.9	4.90 125	2.77 70	3.52 89	3.52 89	0.06 1.5
1 DN25	1.315 33.7	4.90 125	2.77 70	3.51 89	3.51 89	0.06 1.5
$1\frac{1}{4}$ DN32	1.660 42.4	4.90 125	2.76 70	3.52 89	3.52 89	0.06 1.5
2 x 1 DN50 DN25	2.375 x 1.315 60.3 x 33.7	5.31 135	2.80 71	4.03 102	3.73 95	0.06 1.5
$1\frac{1}{4}$ DN32	1.660 42.4	5.31 135	2.80 71	4.03 102	3.73 95	0.06 1.5
$1\frac{1}{2}$ DN40	1.900 48.3	5.27 134	3.19 81	4.00 102	3.69 94	0.06 1.5



Always refer to the current Victaulic publication 34.01 for the most up-to-date dimensional information. Publication 34.01 can be downloaded at victaulic.com.

DIELECTRIC ADAPTERS

No. P47 – Straight Dielectric Adapter (Plain-End x Sweat)

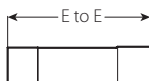

Size		Dimensions – inches/mm
Nominal inches/DN	Actual Outside Diameter inches/mm	E End-to-End
½ DN15	0.840 21.3	4.50 114
¾ DN20	1.050 26.9	4.75 121
1 DN25	1.315 33.7	4.91 125
1 ¼ DN32	1.660 42.4	4.97 126

No. P97 – 90° Elbow Dielectric Adapter (Plain-End x Sweat)

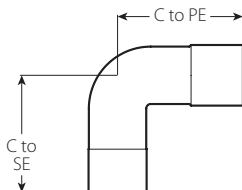

Size		Dimensions – inches/mm	
Nominal inches/DN	Actual Outside Diameter inches/mm	C to SE (Center to Sweat End)	C to PE (Center to Plain End)
½ DN15	0.840 21.3	1.84 47	2.59 66
¾ DN20	1.050 26.9	2.09 53	2.59 66
1 DN25	1.315 33.7	2.54 65	2.72 69
1 ¼ DN32	1.660 42.4	2.82 72	2.88 73



Always refer to the current Victaulic publication 34.01 for the most up-to-date dimensional information. Publication 34.01 can be downloaded at victaulic.com.



VALVE

Series P89 – Ball Valve

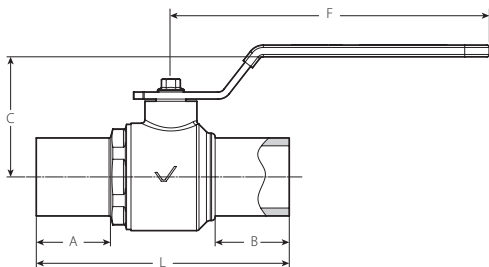

Size		Dimensions – inches/mm				
Nominal inches/DN	Actual Outside Diameter inches/mm	A	B	C	L	F
½ DN15	0.840 21.3	1.25 32	1.25 32	2.50 64	4.00 101	4.25 108
¾ DN20	1.050 26.9	1.25 32	1.25 32	2.63 67	4.15 105	4.25 108
1 DN25	1.315 33.7	1.25 32	1.25 32	2.75 70	4.45 113	5.30 135
1¼ DN32	1.660 42.4	1.25 32	1.25 32	2.88 73	4.75 121	5.30 135
1½ DN40	1.900 48.3	1.63 41	1.63 41	3.00 76	6.10 155	6.10 155
2 DN50	2.375 60.3	1.63 41	1.63 41	3.63 92	6.40 163	6.10 155



Always refer to the current Victaulic publication 34.01 for the most up-to-date dimensional information. Publication 34.01 can be downloaded at victaulic.com.



Helpful Information

[English to Metric Conversion Chart](#)

[Metric to English Conversion Chart](#)

[Decimal Equivalents of Fractions](#)

[Pressure to Feet-of-Head of Water](#)

[Feet-of-Head of Water to Pressure](#)

[Pressure to Meter Water Column](#)

[Meter Water Column to Pressure](#)

[Where to Find Installation Instructions
for Additional Products](#)

English to Metric Conversion Chart

Measurement	English Unit	Abbreviation	Metric Unit	Abbreviation
Length	1 inch	in	25.400 millimeters	mm
	1 foot	ft	0.305 meters	m
Weight	1 ounce	oz	28.349 grams	g
	1 pound	lb	0.454 kilograms	kg
Pressure	1 pound per square inch	psi	6.895 kilopascals	kPa
	1 pound per square inch	psi	0.069 Bars	Bar
Power	1 horsepower	hp	745.700 watts	w
End Load	1 pound	lb	4.448 Newtons	N
Torque	1 foot pound	ft-lb	1.356 Newton meters	N•m
Volume/Time	1 gallon per minute	gpm	3.785 liters per minute	lpm
	1 gallon per minute	gpm	0.004 cubic meters per minute	m ³ /m
Temperature	degrees Fahrenheit	°F	$\frac{(^{\circ}\text{F}-32)}{1.8}$ degrees Celsius	°C

Metric to English Conversion Chart

Measurement	Metric Unit	Abbreviation	English Unit	Abbreviation
Length	1 millimeter	mm	0.039 inches	in
	1 meter	m	3.281 feet	ft
Weight	1 gram	g	0.035 ounces	oz
	1 kilogram	kg	2.205 pounds	lb
Pressure	1 kilopascal	kPa	0.145 pounds per square inch	psi
	1 Bar	Bar	14.504 pounds per square inch	psi
Power	1 watt	w	0.001 horsepower	hp
End Load	1 Newton	N	0.225 pounds	lb
Torque	1 Newton meter	N•m	0.738 foot pounds	ft-lb
Volume/Time	1 liter per minute	lpm	0.264 gallons per minute	gpm
	1 cubic meter per minute	m ³ /m	264.172 gallons per minute	gpm
Temperature	degrees Celsius	°C	$(^{\circ}\text{C} \times 1.8) + 32$ degrees Fahrenheit	°F



Decimal Equivalents of Fractions

Fraction in inches	Decimal Equivalent inches	Decimal Equivalent millimeters
$\frac{1}{64}$	0.016	0.397
$\frac{1}{32}$	0.031	0.794
$\frac{3}{64}$	0.047	1.191
$\frac{1}{16}$	0.063	1.588
$\frac{5}{64}$	0.781	1.984
$\frac{3}{32}$	0.094	2.381
$\frac{7}{64}$	0.109	2.778
$\frac{1}{8}$	0.125	3.175
$\frac{9}{64}$	0.141	3.572
$\frac{5}{32}$	0.156	3.969
$\frac{11}{64}$	0.172	4.366
$\frac{3}{16}$	0.188	4.763
$\frac{13}{64}$	0.203	5.159
$\frac{7}{32}$	0.219	5.556
$\frac{15}{64}$	0.234	5.953
$\frac{1}{4}$	0.250	6.350
$\frac{17}{64}$	0.266	6.747
$\frac{9}{32}$	0.281	7.144
$\frac{19}{64}$	0.297	7.541
$\frac{5}{16}$	0.313	7.938
$\frac{21}{64}$	0.328	8.334
$\frac{1}{3}$	0.333	8.467
$\frac{11}{32}$	0.344	8.731
$\frac{23}{64}$	0.359	9.128
$\frac{3}{8}$	0.375	9.525
$\frac{25}{64}$	0.391	9.922
$\frac{13}{32}$	0.406	10.319
$\frac{27}{64}$	0.422	10.716
$\frac{7}{16}$	0.438	11.113
$\frac{29}{64}$	0.453	11.509
$\frac{15}{32}$	0.469	11.906
$\frac{1}{2}$	0.500	12.700

Fraction in inches	Decimal Equivalent inches	Decimal Equivalent millimeters
$\frac{33}{64}$	0.516	13.097
$\frac{17}{32}$	0.531	13.494
$\frac{35}{64}$	0.547	13.891
$\frac{9}{16}$	0.563	14.288
$\frac{37}{64}$	0.578	14.684
$\frac{19}{32}$	0.594	15.081
$\frac{39}{64}$	0.609	15.478
$\frac{5}{8}$	0.625	15.875
$\frac{41}{64}$	0.641	16.272
$\frac{21}{32}$	0.656	16.669
$\frac{43}{64}$	0.672	17.066
$\frac{11}{16}$	0.688	17.463
$\frac{45}{64}$	0.703	17.859
$\frac{23}{32}$	0.719	18.256
$\frac{47}{64}$	0.734	18.653
$\frac{3}{4}$	0.750	19.050
$\frac{49}{64}$	0.766	19.447
$\frac{25}{32}$	0.781	19.844
$\frac{51}{64}$	0.797	20.241
$\frac{13}{16}$	0.813	20.638
$\frac{53}{64}$	0.828	21.034
$\frac{27}{32}$	0.844	21.431
$\frac{55}{64}$	0.859	21.828
$\frac{7}{8}$	0.875	22.225
$\frac{57}{64}$	0.891	22.622
$\frac{29}{32}$	0.906	23.019
$\frac{59}{64}$	0.922	23.416
$\frac{15}{16}$	0.938	23.813
$\frac{61}{64}$	0.953	24.209
$\frac{31}{32}$	0.969	24.606
$\frac{63}{64}$	0.984	25.003
1	1.000	25.400

Pressure to Feet-of-Head of Water

Pounds per Square inch	Feet of Head
1	2.31
2	4.62
3	6.93
4	9.24
5	11.54
6	13.85
7	16.16
8	18.47
9	20.78
10	23.09
15	34.63
20	46.18
25	57.72
30	69.27
40	92.36
50	115.45
60	138.54
70	161.63
80	184.72
90	207.81

Pounds per Square inch	Feet of Head
100	230.90
110	253.93
120	277.07
130	300.16
140	323.25
150	346.34
160	369.43
170	392.52
180	415.61
200	461.78
250	577.24
300	692.69
350	808.13
400	922.58
500	1154.48
600	1385.39
700	1616.30
800	1847.20
900	2078.10
1000	2309.00

Feet-of-Head of Water to Pressure

Feet of Head	Pounds per Square inch
1	0.43
2	0.87
3	1.30
4	1.73
5	2.17
6	2.60
7	3.03
8	3.46
9	3.90
10	4.33
15	6.50
20	8.66
25	10.83
30	12.99
40	17.32
50	21.65
60	25.99
70	30.32
80	34.65
90	39.98

Feet of Head	Pounds per Square inch
100	43.31
110	47.64
120	51.97
130	56.30
140	60.63
150	64.96
160	69.29
170	73.63
180	77.96
200	86.62
250	108.27
300	129.93
350	151.58
400	173.24
500	216.55
600	259.85
700	303.16
800	346.47
900	389.78
1000	433.00



Pressure to Meter Water Column

kPa	Meter Water Column
10	1.02
15	1.53
20	2.04
25	2.55
30	3.06
40	4.08
50	5.10
60	6.12
70	7.14
80	8.16
90	9.18
100	10.20
110	11.22
120	12.24
130	13.26
140	14.28
150	15.30
160	16.32
170	17.34
180	18.36

kPa	Meter Water Column
180	18.36
190	19.38
200	20.40
250	25.50
300	30.60
400	40.80
500	51.00
600	61.20
700	71.40
800	81.60
900	91.80
1000	102.00
1500	153.00
2000	204.00
2500	255.00
3000	306.00
4000	408.00
5000	510.00
6000	612.00
7000	714.00

Meter Water Column to Pressure

Meter Water Column	kPa
1	9.8
2	19.6
3	29.4
4	39.2
5	49.0
6	58.8
7	68.6
8	78.4
9	88.2
10	98.0
11	108.0
12	118.0
13	127.0
14	137.0
15	147.0
20	196.0
25	245.0
30	194.0
35	343.0
40	392.0

Meter Water Column	kPa
45	441.0
50	490.0
55	539.0
60	588.0
70	686.0
80	784.0
90	882.0
100	980.0
150	1470.0
200	1960.0
250	2450.0
300	2940.0
350	3430.0
400	3920.0
450	4410.0
500	4900.0
550	5390.0
600	5880.0
650	6370.0
700	6860.0



Where to Find Installation Instructions for Additional Products

The following table provides a listing of products and installation information. If you need additional copies of any installation information, contact Victaulic at 1-800-PICK VIC.

NOTE: If two sources of instructions are referenced in this index, Victaulic recommends the use of both to ensure proper product installation.

Product	Where to Find Instructions
FireLock™ Automatic Sprinkler Products	I-40
FireLock™ Fire Protection Valves and Accessories	Manual Shipped with Valve or Accessory
Pipe Preparation Tools	Manual Shipped with Tool
Vic-Press™ Schedule 10S System Products	I-P500
VicFlex™ Products	Instructions Shipped with Product
Victaulic Aquamine™ Spline Couplings	I-Aquamine
Victaulic Bolted Split-Sleeve Couplings	Instructions Shipped with Coupling
Series 317 AWWA Check Valve	I-317
Series 365 AWWA <i>Vic-Plug</i> Valve (3–12-inch/88.9–323.9-mm sizes)	I-365/366/377.3-12
Series 377 <i>Vic-Plug</i> Balancing Valve	I-365/366/377.3-12
Series 608N Copper Connection Butterfly Valve	I-600
Series 700 Butterfly Valve	Manual Shipped with Valve and I-100
Series 705 FireLock™ Butterfly Valve	I-765/705
Series 706 Butterfly Valve	I-100
Series 707C Supervised Closed Butterfly Valve	I-766/707C
Series 709 Butterfly Valve	I-100
Series 712/712S Swinger Check Valve	I-100
Series 713 Swinger Check Valve	I-100
Series 716H/716 <i>Vic-Check</i> Valve	I-100
Series 717H/717 Check Valve	I-100
Series 717HR/717R Check Valve	I-100
Series 723/723S Diverter Ball Valve	I-100
Series 726/726S <i>Vic-Ball</i> Valve	I-100
Series 728 FireLock™ Ball Valve	I-728
Series 730 <i>Vic-Strainer</i> Tee Type	I-730/732/AGS
Series W730 AGS <i>Vic-Strainer</i> Tee Type	I-730/732/AGS
Series 731-D Suction Diffuser	I-731D
Series W731-D AGS Suction Diffuser	I-731I/W731I
Series 732 <i>Vic-Strainer</i> Wye Type	I-730/732/AGS
Series W732 AGS <i>Vic-Strainer</i> Wye Type	I-730/732/AGS



Product	Where to Find Instructions
Series 733 Venturi Indicator	I-100
Series 747M FireLock™ Zone Control Riser Module Assembly	I-747M
Series 761 Vic-300 MasterSeal™ Butterfly Valve	I-VIC300MS and I-100
Series W761 AGS Vic-300 Butterfly Valve	I-AGS.GO and I-100
Series 763 Butterfly Valve	I-100
Series 765 FireLock™ Butterfly Valve	I-765/705
Series 766 Butterfly Valve with Supervised-Closed Switches	I-766/707C
Series 779 Venturi Check Valve	I-100
Series 782/783 Bypass	Instructions Shipped with Valve
Series 785 TBVS Sweated-End Mini Circuit Balancing Valve	Instructions Shipped with Valve
Series 786 STAS Soldered-End Circuit Balancing Valve	Instructions Shipped with Valve
Series 787 STAD NPT Female Threaded Circuit Balancing Valve	Instructions Shipped with Valve
Series 788 STAF Flanged-End Circuit Balancing Valve	Instructions Shipped with Valve
Series 789 STAG Grooved-End Circuit Balancing Valve	Instructions Shipped with Valve
Style 005 FireLock™ Rigid Coupling	I-100
Style 009N FireLock EZ™ Rigid Coupling	I-009H/009/009V and I-100
Style 07 Zero-Flex™ Rigid Coupling (1–12-inch/33.7–323.9-mm sizes)	I-100
Style 07 Zero-Flex™ Rigid Coupling (14–24-inch/355.6–610.0-mm sizes)	I-100 and IT-07
Style W07 AGS Rigid Coupling	I-100 and I-W07/W77
Style 22 Coupling for <i>Vic-Ring</i> Adapters and Shouldered-End Pipe	I-6000
Style 31 Coupling for AWWA Ductile Iron	I-300
Style 31 Coupling for <i>Vic-Ring</i> Adapters and Shouldered-End Pipe	I-6000
Style 41 Coupling for <i>Vic-Ring</i> Adapters and Shouldered-End Pipe	I-6000
Style 44 Coupling for <i>Vic-Ring</i> Adapters and Shouldered-End Pipe	I-6000
Style 72 Outlet Coupling	I-100
Style 75 Flexible Coupling	I-100
Style 77/77A/77S Flexible Coupling	I-100
Style W77 AGS Flexible Coupling	I-100 and I-W07/W77



Product	Where to Find Instructions
Style 78/78A Snap-Joint™ Coupling	I-100
Style 89 Rigid Coupling for Stainless Steel	I-100 and IT-89
Style W89 AGS Rigid Coupling for Stainless Steel	I-W89
Style 99 <i>Roust-A-Bout</i> Coupling for Plain-End Steel	I-100 and IT-99
Style 107H/107 QuickVic™ Rigid Coupling for Steel Pipe	I-107H/107 and I-100
Style 150 <i>Mover</i> Expansion Joint	Submittal 09.04
Style 155 Expansion Joint	Submittal 09.05
Style W155 AGS Expansion Joint	Submittal 20.12
Style 177 QuickVic™ Flexible Coupling for Steel Pipe	I-177 and I-100
Style 307 Coupling for Grooved IPS Steel to Grooved AWWA Ductile Iron	I-300
Style 341 <i>Vic-Flange</i> Adapter for AWWA Ductile Iron	I-300
Style 441 <i>Vic-Flange</i> for Stainless Steel	I-100 and I-441
Style 475 Lightweight, Flexible Stainless Steel Coupling	I-100
Style 489 Rigid Coupling for Stainless Steel (1½–4-inch/48.3–114.3-mm sizes)	I-100 and IT-489.2-4
Style 489 Rigid Coupling for Stainless Steel (6–12-inch and 139.7–318.5-mm metric and JIS sizes)	I-100 and IT-489
Style 606 Rigid Coupling for Copper Tubing	I-600
Style 607 QuickVic™ Rigid Coupling for Copper Tubing	I-607 and I-600
Style 622 <i>Mechanical-T</i> Bolted Branch Outlet for Copper Tubing	I-622 and I-600
Style 641 <i>Vic-Flange</i> Adapter for Copper Tubing	I-600
Style 707-IJ Transition Coupling for NPS to JIS	I-100
Style 720 TestMaster™ II Alarm Test Module	I-720
Style 720 TestMaster™ II Alarm Test Module with Pressure Relief Option	I-720PR
Style 730 <i>Vic-Strainer</i> Tee-Type	I-730/732
Style 732 Wye-Type <i>Vic-Strainer</i>	I-730/732
Style 733 Venturi Flow Metering Sensor	I-100
Style 734/734S Orifice/Indicator Flow Metering System	I-100



Product	Where to Find Instructions
Style 735 Fire Pump Test Meter	I-100
Style 738 Portable Differential Meter	Instructions Shipped with Meter
Style 739 Portable Master Meter	Instructions Shipped with Meter
Style 740 CBI Meter	Instructions Shipped with Meter
Style 741 IPS and Metric <i>Vic-Flange</i> Adapter	I-100
Style W741 AGS <i>Vic-Flange</i> Adapter	I-100 and IT-W741
Style 743 <i>Vic-Flange</i> Adapter	I-100
Style 744 FireLock™ Flange Adapter	I-100
Style 750 Reducing Coupling	I-100
Style 791 <i>Vic-Boltless</i> Coupling	I-100
Style 808 Coupling	I-808
Style 920 and 920N <i>Mechanical-T</i> Outlets	I-100 and I-920N
Style 922 FireLock™ Outlet-T	I-100 and I-922
Style 923 <i>Vic-Let</i> Strapless Outlet	I-100 and I-923
Style 924 <i>Vic-O-Well</i> Strapless Thermometer Outlet	I-100
Style 926 <i>Mechanical-T</i> Spigot Assembly	I-100 and I-926
Style 931 <i>Vic-Tap II Mechanical-T</i>	VT-II
Style 994 <i>Vic-Flange</i> Adapter for HDPE	I-900 and IT-994
Style 995N Coupling for Plain- End IPS and Metric HDPE	I-900 and IT-995
Style 997 Transition Coupling for HDPE to Steel	I-900 and IT-997
Style 2970 Aquamine™ Coupling for Plain-End IPS PVC	IT-2970
Style 2971 Aquamine™ Transition Coupling for Plain-End IPS PVC to Plain-End HDPE	IT-2971
Style 2972 Aquamine™ Transition Coupling for Plain-End IPS PVC to Grooved IPS Steel	IT-2972
Style HP-70 Rigid Coupling (2–12-inch/60.3–323.9-mm sizes)	I-100
Style HP-70 Rigid Coupling (14–16-inch/355.6–406.4-mm sizes)	I-100 and IT-70
Style HP-70ES Rigid Coupling with EndSeal™ Gasket (2–12-inch/60.3–323.9-mm sizes)	I-100



**U.S./World Headquarters**

4901 Kesslersville Road
Easton, PA 18040 USA

◀ victauliclocations.com

EMEA

Prijkelstraat 36
9810 Nazareth, Belgium

Asia Pacific

Unit 808, Building B
Hongwell International Plaza
No.1602 West Zhongshan Road
Shanghai, China 200235

I-P100**11831 REV A 04/2018****Z00P100PHB**

Victaulic and all other Victaulic marks are the trademarks or registered trademarks of Victaulic Company, and/or its affiliated entities, in the U.S. and/or other countries. All other trademarks listed herein are the property of their respective holders, in the U.S. and/or other countries. The terms "Patented" or "Patent Pending" refer to design or utility patents or patent applications for articles and/or methods of use in the United States and/or other countries.

© 2018 VICTAULIC COMPANY. ALL RIGHTS RESERVED.

