

Service Manual

Ventilating Fan
(North America Market)

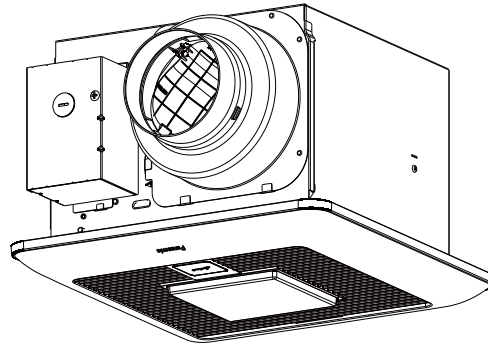

FV-0511VKSL2

⚠ WARNING

This service information is designed for experienced repair technicians only and is not designed for use by the general public. It does not contain warnings or cautions to advise non-technical individuals of potential dangers in attempting to service a product. Products powered by electricity should be serviced or repaired only by experienced professional technicians. Any attempt to service or repair the product or products dealt with in this service information by anyone else could result in serious injury or death.

IMPORTANT SAFETY NOTICE

There are special components used in this equipment which are important for safety. These parts are marked by ⚠ in the Schematic Diagrams, Exploded Views and Replacement Parts List. It is essential that these critical parts should be replaced with manufacturer's specified parts to prevent shock, fire or other hazards. Do not modify the original design without the manufacturer's approval. Please have a static electricity depletion process in place before handling these components.. Please use gloves when handling PCB parts during the repair process..

CONTENTS	PAGE
1.Specification-----	1, 2
2.Parts Identification-----	3 ~ 7
3.Wiring Diagram-----	8
4.Parts List-----	9, 10

1. Specification

■ Specification for base Model fans

Model No.	Air Direction	Voltage (V)	Frequency (Hz)	Duct Diameter (inches)	Air Volume at 0.1 "WG (CFM)	Noise (sones)	Speed (rpm)	Power (W)		Weight Lb. (Kg)
								Fan	Lighting unit	
FV-0511VKSL2	Exhaust	120	60	4 or 6	110	0.4	958	10.5	10	10.6 (4.8)
					80	<0.3	811	5.3		
					50	<0.3	730	3.2		

HVI Certified performance based on HVI Procedures 915, 916, and 920.

■ Specifications for Multi Speed fans

Model No.	Air Direction	Voltage (V)	Frequency (Hz)	Duct Diameter (inches)	Air Volume at 0.1 "WG (CFM)	Noise (sones)	Speed (rpm)	Power (W)		Weight Lb. (Kg)
								Fan	Lighting unit	
FV-0511VKSL2	Exhaust	120	60	4 or 6	100	<0.3	908	8.2	10	10.6 (4.8)
					90	<0.3	868	6.7		
					80	<0.3	811	5.3		
					70	<0.3	785	4.6		
					60	<0.3	750	3.7		
					50	<0.3	730	3.2		
					40	<0.3	710	2.7		
					30	<0.3	720	2.5		
					0	–	–	0.5 (*)		

Reference performance based on HVI Procedures 915, 916, and 920. [(*) Standby wattage.]

1. Specification

Remark: We divide this model into Version A & Version B, because of different motor and Main PCB Section, please put attention with identification of parts when you request a service parts.

Parts for Version A

Motor

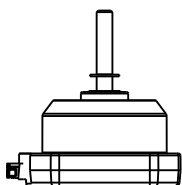

Side view

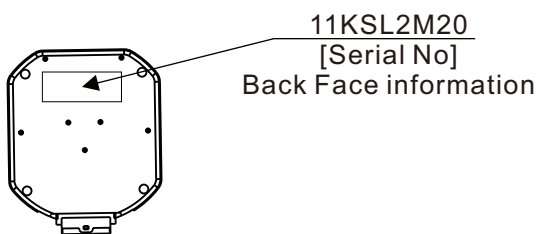

Parts for Version B

Motor

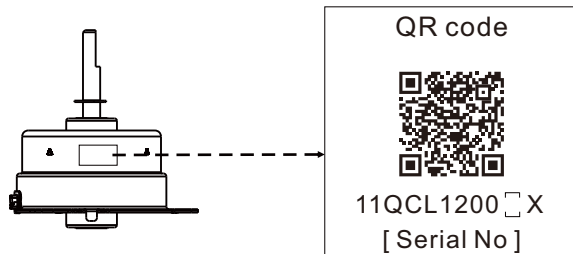

Side view

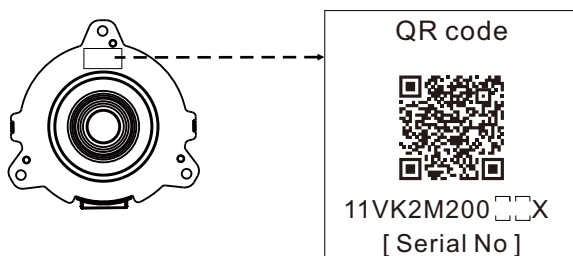

Top Cover view

Main PCB Section

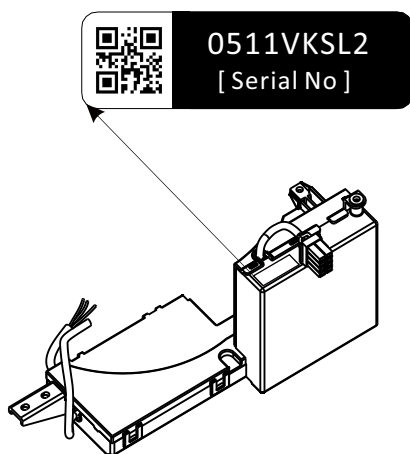

Motor Support

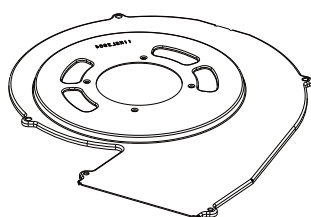

Main PCB Section

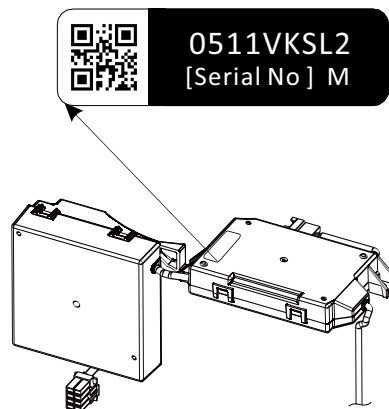

Motor Support

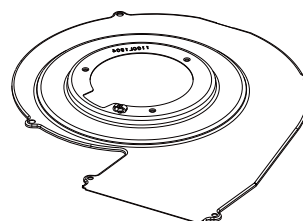

Motor	Main PCB	Judgment
Version A	Version A	(OK) Work
Version A	Version B	(NG) Do Not Work
Version B	Version B	(OK) Work
Version B	Version A	(NG) Do Not Work

2. Parts Identification

FV-0511VKSL2

Main Body Section

Parts for Version A

Name Plate

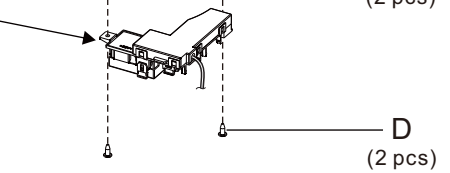
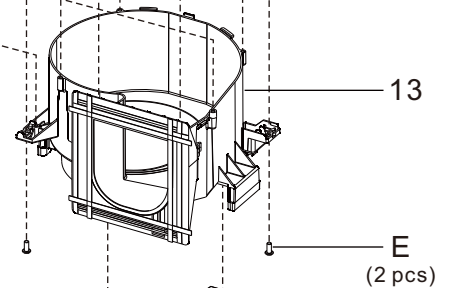
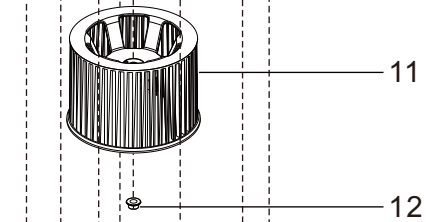
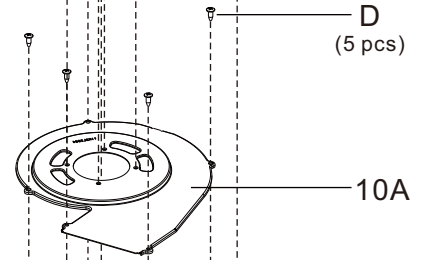
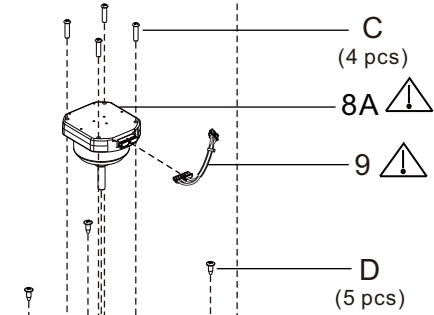
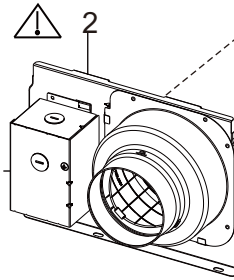
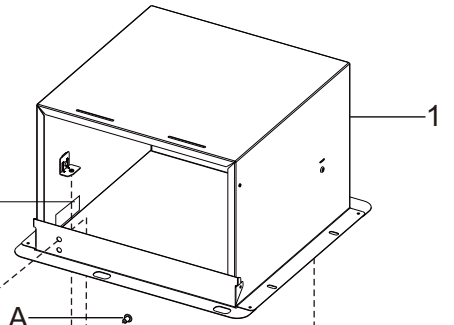

Main PCB Section

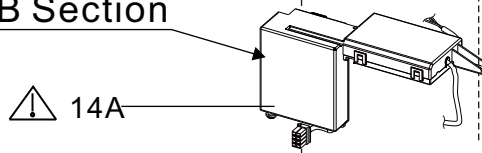

Base PCB Section

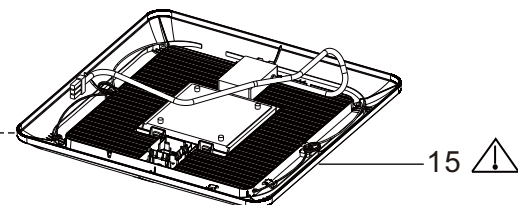
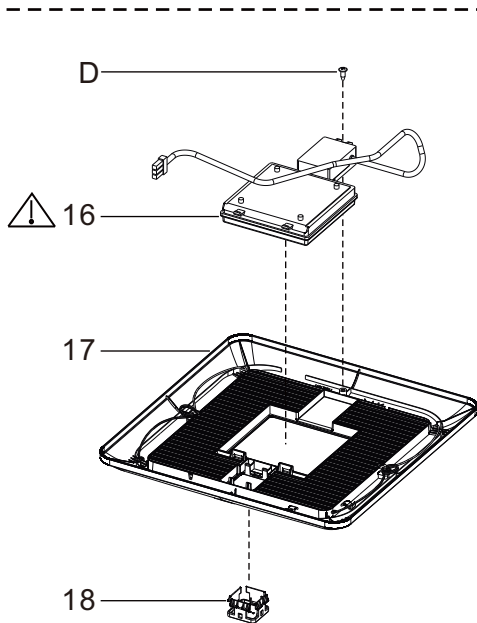

2. Parts Identification

FV-0511VKSL2

Main Body Section

Parts for Version B

Name Plate

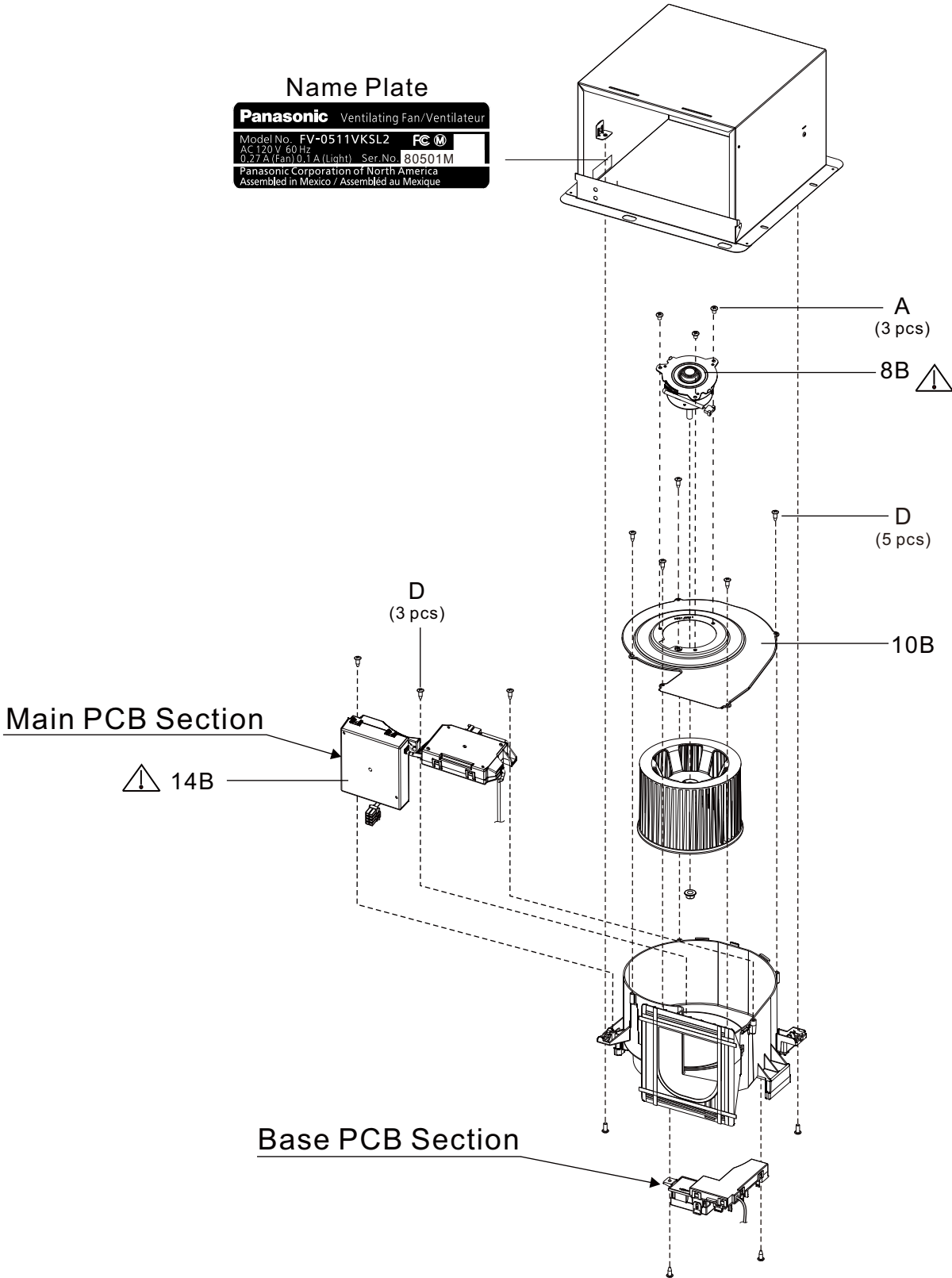

2.Parts Identification

FV-0511VKSL2

Main PCB Section

Parts for Version A

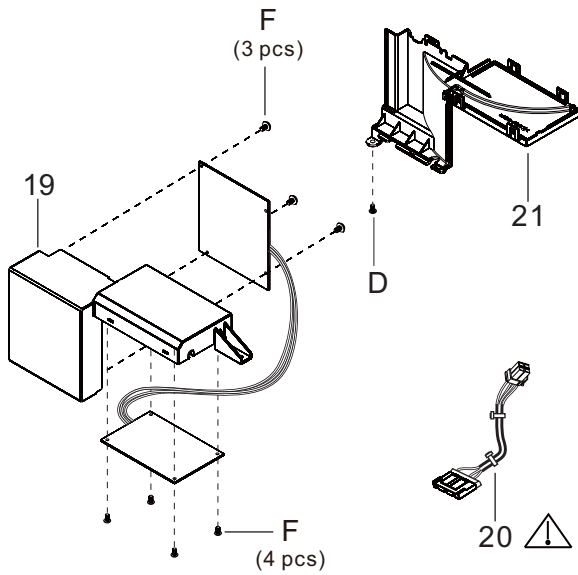

Parts for Version B

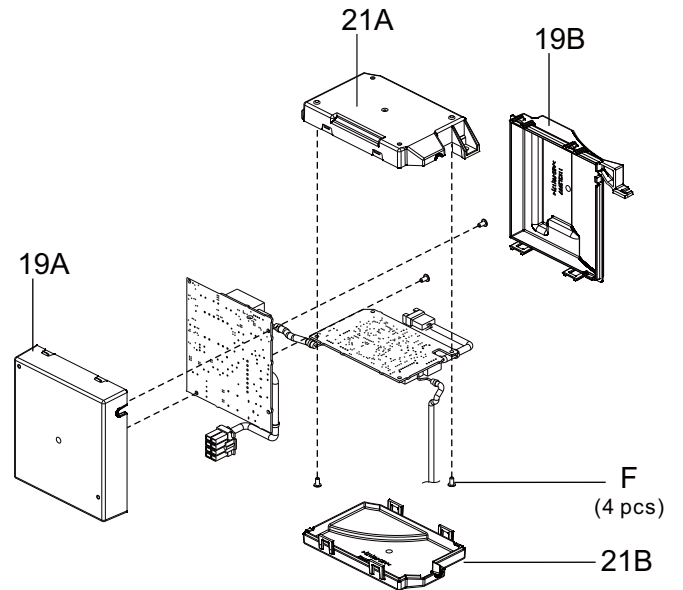

Base PCB Section

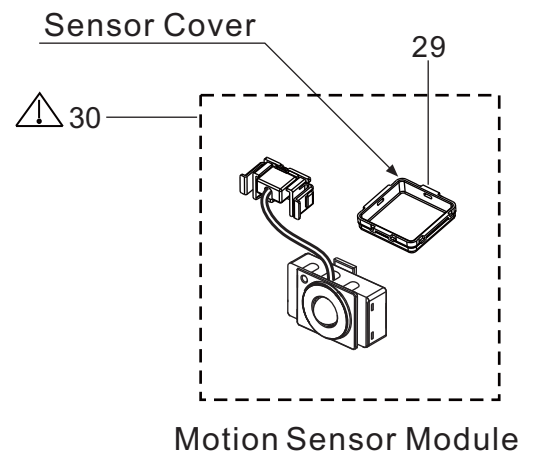
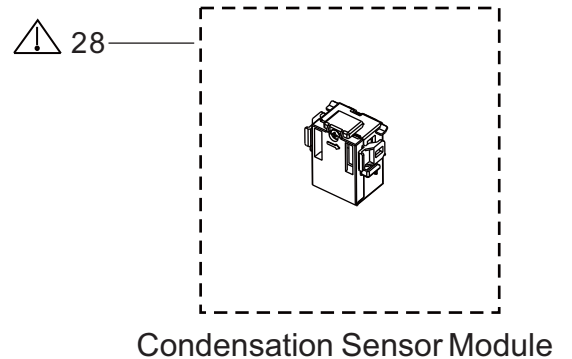
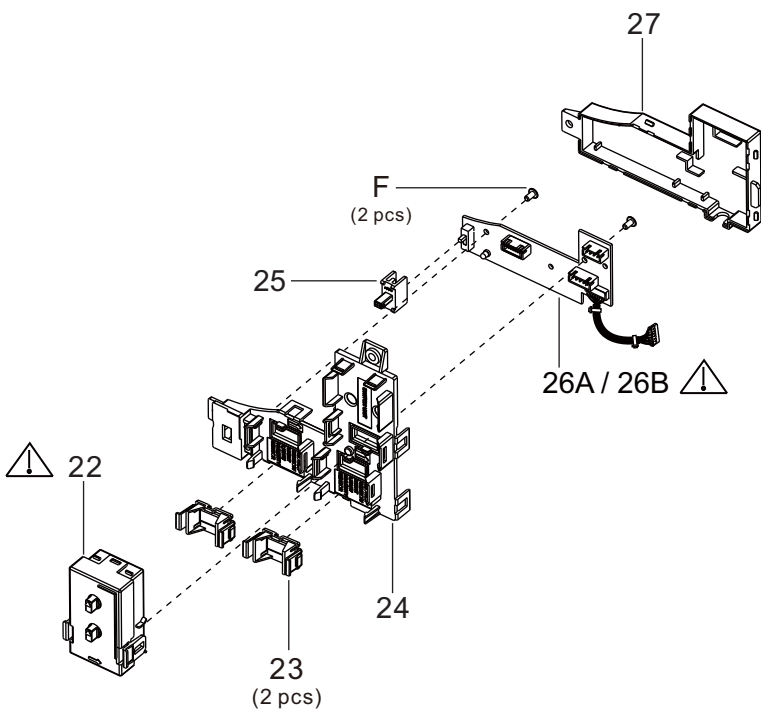

- 1, Please note that above parts with (No. 28, 30) are the optional parts base on Different customer's request.
- 2, If install the motion sensor control, please remove the ornamental cover and Replace the sensor Cover.

2. Parts Identification

FV-0511VKSL2

Packing Section

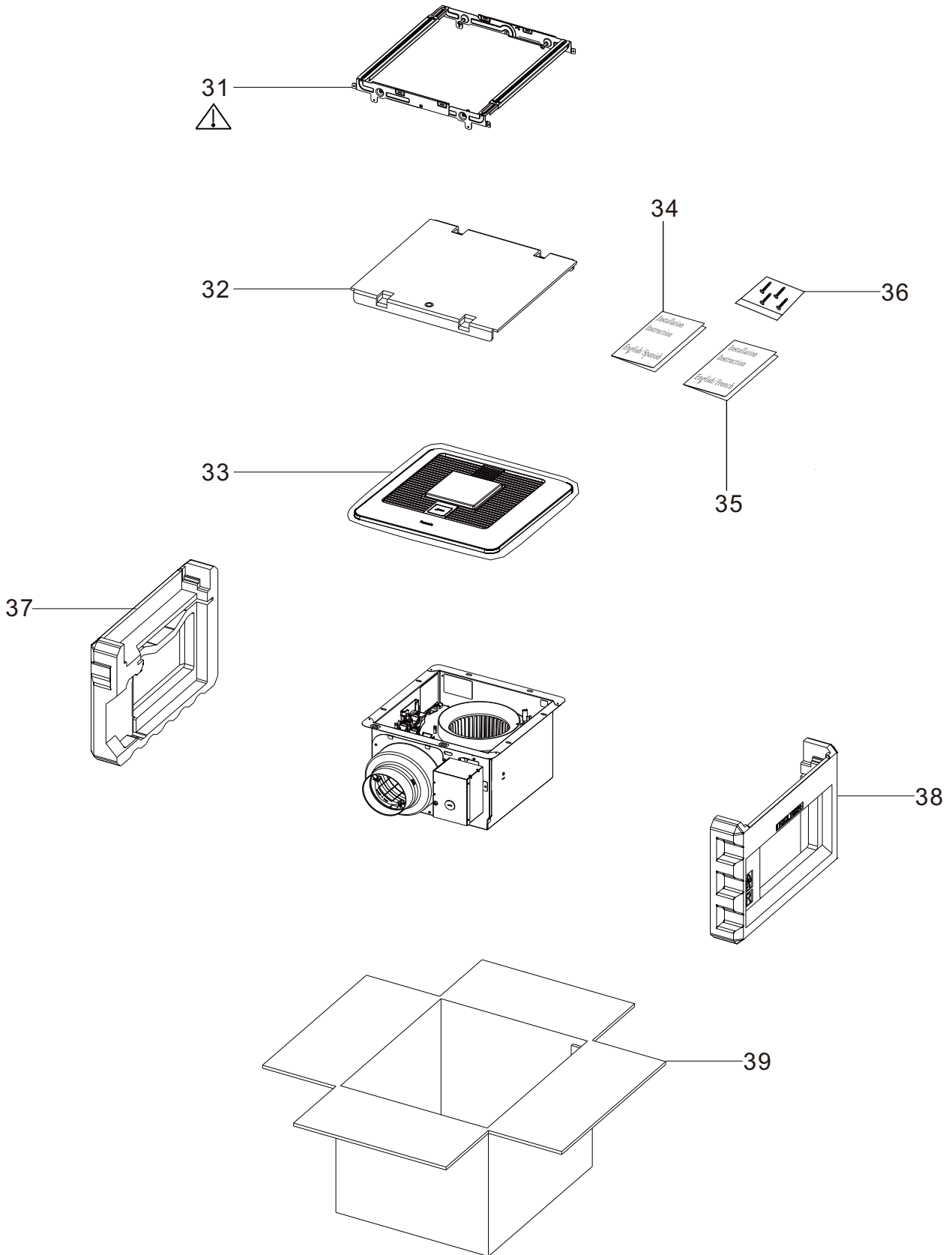

2. Parts Identification

FV-0511VKSL2

Main Label

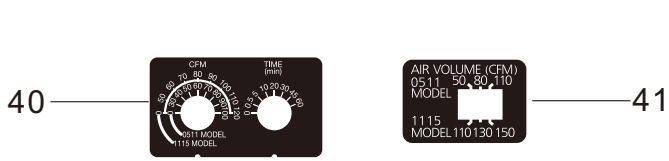

WARNING:
 1. Before service or cleaning unit, switch power off at service panel and lock service panel to prevent power from being switched on accidentally.
 2. Acceptable for use over a bathtub or shower when installed in a GFCI protected branch circuit.

CAUTION:
 To reduce the risk of injury to persons, install fan at least 2.1m(7 feet) above the floor.

ATTENTION:
 1. Pour l'entretien ou le nettoyage, mettre l'appareil hors tension au niveau de la façade des commandes et du panneau de verrouillage des commandes afin d'éviter toute mise sous tension accidentelle.
 2. Convient pour utilisation au-dessus d'une baignoire ou d'une douche si raccordé à un circuit de dérivation protégé aux normes GFCI.
 3. Afin de réduire les risques de blessures corporelles, installer le ventilateur à au moins 2,1m(7 pieds) du sol.

45

42A

8 Means Year: 2018
 05 Means Month
 01 Means Day

42B

8 Means Year: 2018
 05 Means Month
 01 Means Day
 M: In House MOTOR

43

Not for use in cooking area-See installation instructions. Non destiné à la zone de cuisson-Voir instructions d'installation. No usar en áreas donde se cocina- Consulte las instrucciones de instalación.

46

Secure screw tightly for ground continuity
 Vissez fermement pour la continuité de la mise à la terre

44

SCAN CODE FOR WIRING INSTRUCTIONS

47

3. Wiring Diagram

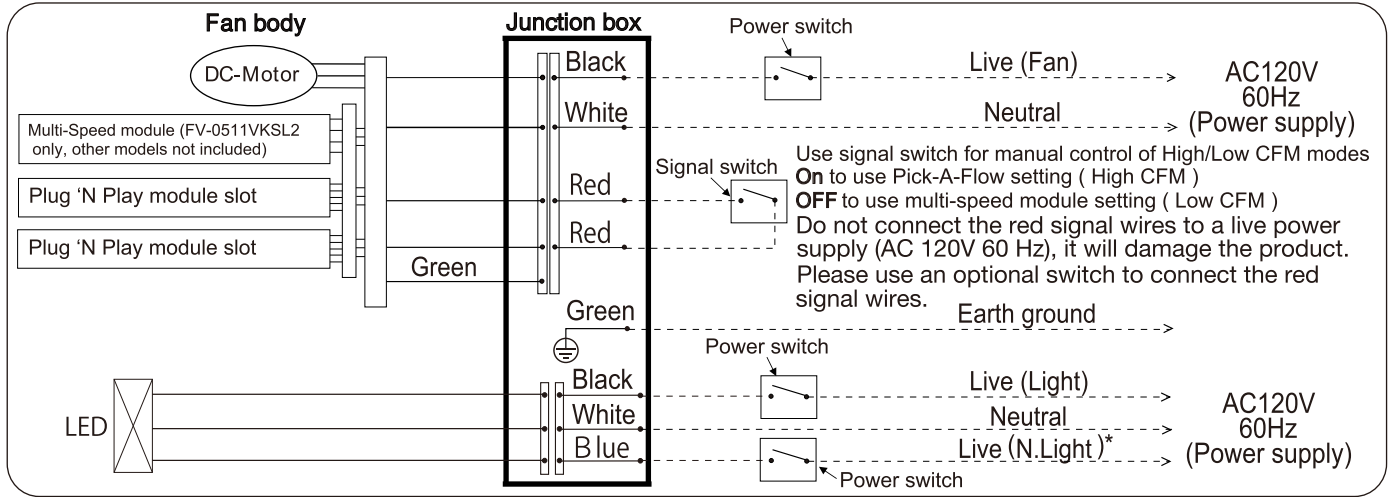

*Night light

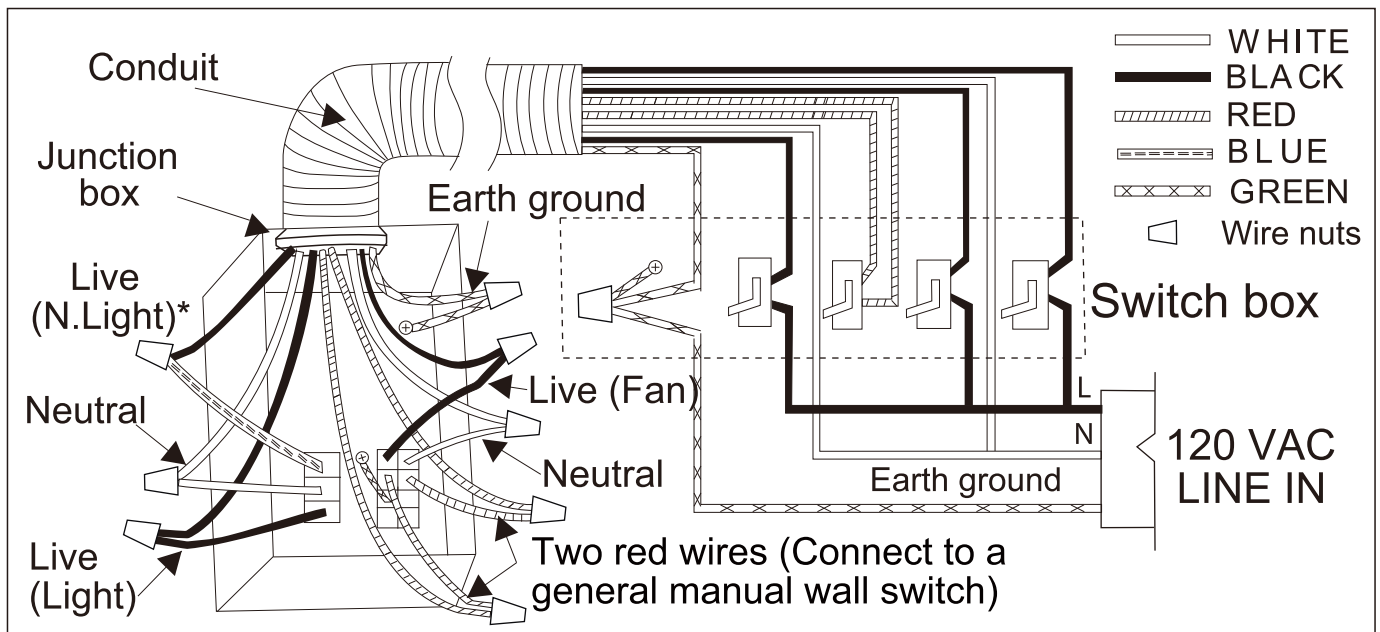

* Night Light

4. Parts List

FV-0511VKSL2

Main Body Section

No.	Part No.	Part Name	Q'ty	Remark
1	FFV11QCL1900C	Frame Assembly	1	
2	FFV11KSL2910	Adapter Assembly	1	△
3	FFV11KSL2913	Connector Plate	1	
4	FFV1340008S	Ground Wire	1	△
5	FFV11KSL2301	Connector Assy	1	△
6	FFV11QCL1341A	Connector Assy (L)	1	△
7	FFV11QCL1912A	Junction Cover	1	
8A	FFV11KSL2M20	Motor	1	△
8B	FFV11VK2M200	Motor	1	△
9	FFV4620109S	Motor Lead Wire Assembly	1	
10A	FFV11KSL2904	Motor Support	1	
10B	FFV11QCL1904C	Motor Support	1	
11	FFV0400114S	Blade	1	
12	FFV7020021S	Nut	1	
13	FFV11QCL1906B	Casing section	1	
14A	FFV0511VKL2PCB	Main PCB Section	1	Include Base PCB section △
14B	FFV0511VK2M	Main PCB Section	1	Include Base PCB section △
15	FFV0511VKSL2	Grill Assembly	1	
16	FFV3400148S	Led Unit	1	△
17	FFV0511VQCL1S	Grill Section	1	
18	FFV2220074S	Ornamental Cover	1	
A	FFVXTT4-8FFJ	Screw (ST4-8)	4	△
B	FFVXYM4DC8BN	Screw w/washer(M4-8)	1	△
C	FFV7000109S	Stainless Steel Screw	4	
D	FFV7000089S	Screw (ST4-12)	10	
E	FFV7000065S	Bind Screw	2	

Main PCB Section

No.	Part No.	Part Name	Q'ty	Remark
19	FFV3740027S	Main PCB Box	1	
19A	FFV11KSL2996	Power PCB box	1	
19B	FFV11KSL2997	Power PCB Cover	1	
20	FFV11KSL2310	Power Lead Wire	1	
21	FFV3740014S	Main PCB Cover	1	
21A	FFV11KSL2991	Control PCB Box	1	
21B	FFV11KSL2992	Control PCB Cover	1	
D	FFV7000089S	Screw (ST4-12)	1	
F	FFVXTN3-8GFJ	Screw (M3-8)	11	

4. Parts List

FV-0511VKSL2

Base PCB Section

No.	Part No.	Part Name	Q'ty	Remark
22	FFV5530071S	Multi-Speed Module	1	⚠
23	FFV0900063S	Connector Cover	2	
24	FFV0410001S	Base PCB Cover	1	
25	FFV5530072S	Variable Speed Switch	1	
26A	FFV0410002S	Base PCB Assembly	1	⚠
26B	FFV11VK25100	Base PCB Assembly	1	⚠
27	FFV0410003S	Base PCB Box	1	
28	FFV0010237S	Condensation Sensor Module	1	⚠
29	FFV2220051S	Sensor Cover	1	
30	FFV3740029S	Motion Sensor Module	1	Include Sensor Cover ⚠
F	FFVXTN3-8GFJ	Screw (M3-8)	2	

Packing Section

No.	Part No.	Part Name	Q'ty	Remark
31	FFV11QCL1920	Hanger Assy	1	⚠
32	FFV4710381S	Grill Pad Assy	1	
33	FFV4650016S	Poly Cover	1	
34	FFV11KSL2420	Installation Inst	1	English / Spanish For USA Market
35	FFV11KSL2421	Installation Inst	1	English / French For CANADA Market
36	FFV11KSL1M031A	Accessory A	1	
37	FFV11QCL1891	Left Pad	1	
38	FFV11QCL1892	Right Pad	1	
39	FFV11KSL2400	Packing Case Assy	1	

Main Label

No.	Part No.	Part Name	Q'ty	Remark
40	FFV11KSL2011	Switch Label	1	
41	FFV11KSL2012	CFM Label	1	
42A	FFV11KSL2050	Name Plate	1	
42B	FFV11KSL2M50	Name Plate	1	
43	FFV0810011S	Caution Label 1	1	
44	FFV11KSL2055	QR Code Label	1	
45	FFV0810010S	Caution Label	1	
46	FFV6730045S	Warning Label	1	
47	FFV2260003S	Holograph Label	1	