



SERVICE PARTS LIST

BULLETIN NO.
54-49-3155-1

SPECIFY CATALOG NO. AND SERIAL NO. WHEN ORDERING PARTS		REVISED BULLETIN	DATE
PIPE WRENCHES			Nov. 2018
STRAIGHT PIPE WRENCHES (Steel and Aluminum)			
CATALOG NO.	48-22-7106	6" Wrench	Page 1
	48-22-7108	8" Wrench	Page 1
	48-22-7110, 48-22-7210, 48-22-7213	10" Wrenches	Page 2
	48-22-7112, 48-22-7212	12" Wrenches	Page 2
	48-22-7114, 48-22-7214	14" Wrenches	Page 2
	48-22-7118, 48-22-7218	18" Wrenches	Page 2
	48-22-7124, 48-22-7224	24" Wrenches	Page 2
	48-22-7136, 48-22-7236	36" Wrenches	Page 3
	48-22-7148, 48-22-7248	48" Wrenches	Page 3
	48-22-7160	60" Wrench	Page 3
OFFSET PIPE WRENCHES (Aluminum)			
CATALOG NO.	48-22-7184	14" Wrench	Page 4
	48-22-7185	18" Wrench	Page 4
	48-22-7182	24" Wrench	Page 4
OFFSET HEX PIPE WRENCH and SMOOTH JAW WRENCH			
CATALOG NO.	48-22-7171	10" Offset Hex	Page 5
	48-22-7186	12" Smooth Jaw	Page 5

EXAMPLE:
Component Parts (Small #) Are Included
When Ordering The Assembly (Large #).

**SEE PAGE SIX FOR CAT. NO. 48-22-7314
14" CHEATER ADJUSTABLE PIPE WRENCH**

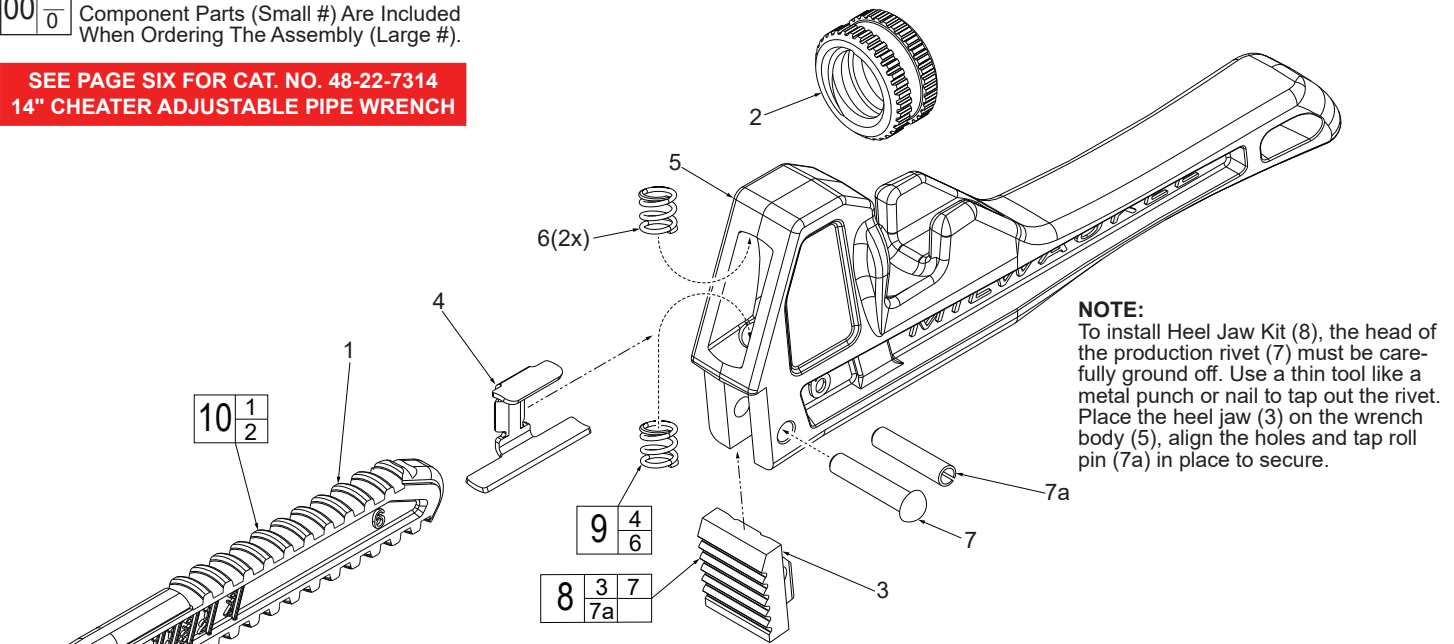

NOTE:
To install Heel Jaw Kit (8), the head of the production rivet (7) must be carefully ground off. Use a thin tool like a metal punch or nail to tap out the rivet. Place the heel jaw (3) on the wrench body (5), align the holes and tap roll pin (7a) in place to secure.

48-22-7106 6" STEEL STRAIGHT PIPE WRENCH

FIG.	PART NO.	DESCRIPTION OF PART	NO. REQ.
1	-----	6" Hook Jaw	(1)
2	-----	6" Adjustment Nut	(1)
3	-----	6" Heel Jaw	(1)
4	-----	Spring Plate Bracket	(1)
5	-----	6" Straight Wrench Body	(1)
6	-----	Coil Spring	(2)
7	-----	Rivet	(1)
7a	-----	Roll Pin	(1)
8	43-90-3002	6" Heel Jaw with Rivet & Roll Pin Kit	(1)
9	40-50-0446	6" Spring and Bracket Kit	(1)
10	43-90-3004	6" Hook Jaw with Adjustment Nut Kit	(1)

48-22-7108 8" STEEL STRAIGHT PIPE WRENCH

FIG.	PART NO.	DESCRIPTION OF PART	NO. REQ.
1	-----	8" Hook Jaw	(1)
2	-----	8" Adjustment Nut	(1)
3	-----	8" Heel Jaw	(1)
4	-----	Spring Plate Bracket	(1)
5	-----	8" Straight Wrench Body	(1)
6	-----	Coil Spring	(2)
7	-----	Rivet	(1)
7a	-----	Roll Pin	(1)
8	43-90-3003	8" Heel Jaw with Rivet & Roll Pin Kit	(1)
9	40-50-0447	8" Spring and Bracket Kit	(1)
10	43-90-3005	8" Hook Jaw with Adjustment Nut Kit	(1)

00 0

EXAMPLE:

Component Parts (Small #) Are Included When Ordering The Assembly (Large #).

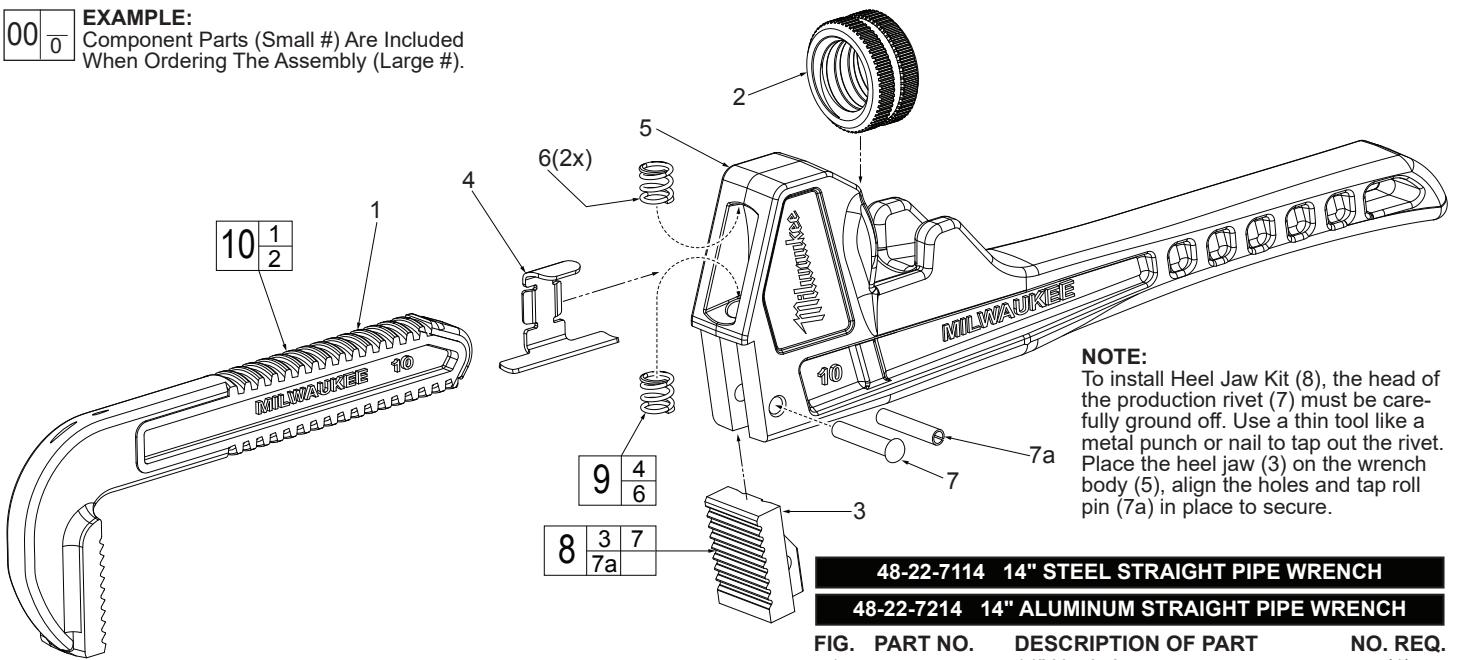

NOTE:
To install Heel Jaw Kit (8), the head of the production rivet (7) must be carefully ground off. Use a thin tool like a metal punch or nail to tap out the rivet. Place the heel jaw (3) on the wrench body (5), align the holes and tap roll pin (7a) in place to secure.

48-22-7110 10" STEEL STRAIGHT PIPE WRENCH

48-22-7210 10" ALUMINUM STRAIGHT PIPE WRENCH

48-22-7213 10" ALUMINUM STRAIGHT PIPE WRENCH

FIG.	PART NO.	DESCRIPTION OF PART	NO. REQ.
1	-----	10" Hook Jaw	(1)
2	-----	10" Adjustment Nut	(1)
3	-----	10" Heel Jaw	(1)
4	-----	Spring Plate Bracket	(1)
5	-----	10" Straight Wrench Body	(1)
6	-----	Coil Spring	(2)
7	-----	Rivet	(1)
7a	-----	Roll Pin	(1)
8	43-90-2000	10" Heel Jaw with Rivet & Roll Pin Kit	(1)
9	40-50-3230	10" Spring and Bracket Kit	(1)
10	43-90-0191	10" Hook Jaw with Adjustment Nut Kit	(1)

48-22-7112 12" STEEL STRAIGHT PIPE WRENCH

48-22-7212 12" ALUMINUM STRAIGHT PIPE WRENCH

FIG.	PART NO.	DESCRIPTION OF PART	NO. REQ.
1	-----	12" Hook Jaw	(1)
2	-----	12" Adjustment Nut	(1)
3	-----	12" Heel Jaw	(1)
4	-----	Spring Plate Bracket	(1)
5	-----	12" Straight Wrench Body	(1)
6	-----	Coil Spring	(2)
7	-----	Rivet	(1)
7a	-----	Roll Pin	(1)
8	43-90-2001	12" Heel Jaw with Rivet & Roll Pin Kit	(1)
9	40-50-3231	12" Spring and Bracket Kit	(1)
10	43-90-0192	12" Hook Jaw with Adjustment Nut Kit	(1)

48-22-7114 14" STEEL STRAIGHT PIPE WRENCH

48-22-7214 14" ALUMINUM STRAIGHT PIPE WRENCH

FIG.	PART NO.	DESCRIPTION OF PART	NO. REQ.
1	-----	14" Hook Jaw	(1)
2	-----	14" Adjustment Nut	(1)
3	-----	14" Heel Jaw	(1)
4	-----	Spring Plate Bracket	(1)
5	-----	14" Straight Wrench Body	(1)
6	-----	Coil Spring	(2)
7	-----	Rivet	(1)
7a	-----	Roll Pin	(1)
8	43-90-2001	14" Heel Jaw with Rivet & Roll Pin Kit	(1)
9	40-50-3232	14" Spring and Bracket Kit	(1)
10	43-90-0193	14" Hook Jaw with Adjustment Nut Kit	(1)

48-22-7118 18" STEEL STRAIGHT PIPE WRENCH

48-22-7218 18" ALUMINUM STRAIGHT PIPE WRENCH

FIG.	PART NO.	DESCRIPTION OF PART	NO. REQ.
1	-----	18" Hook Jaw	(1)
2	-----	18" Adjustment Nut	(1)
3	-----	18" Heel Jaw	(1)
4	-----	Spring Plate Bracket	(1)
5	-----	18" Straight Wrench Body	(1)
6	-----	Coil Spring	(2)
7	-----	Rivet	(1)
7a	-----	Roll Pin	(1)
8	43-90-2002	18" Heel Jaw with Rivet & Roll Pin Kit	(1)
9	40-50-3233	18" Spring and Bracket Kit	(1)
10	43-90-0194	18" Hook Jaw with Adjustment Nut Kit	(1)

48-22-7124 24" STEEL STRAIGHT PIPE WRENCH

48-22-7224 24" ALUMINUM STRAIGHT PIPE WRENCH

FIG.	PART NO.	DESCRIPTION OF PART	NO. REQ.
1	-----	24" Hook Jaw	(1)
2	-----	24" Adjustment Nut	(1)
3	-----	24" Heel Jaw	(1)
4	-----	Spring Plate Bracket	(1)
5	-----	24" Straight Wrench Body	(1)
6	-----	Coil Spring	(2)
7	-----	Rivet	(1)
7a	-----	Roll Pin	(1)
8	43-90-2003	24" Heel Jaw with Rivet & Roll Pin Kit	(1)
9	40-50-3234	24" Spring and Bracket Kit	(1)
10	43-90-0195	24" Hook Jaw with Adjustment Nut Kit	(1)