

INSTRUCTIONS FOR MODELS

STW-370 Thermostatic Mixing Valve

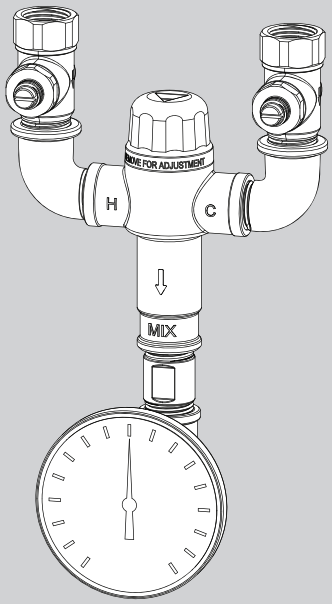

NEED HELP?

For additional assistance or service please contact:

SPEAKMAN®

800-537-2107

customerservice@speakman.com

www.speakman.com

92-STW-370-04

TOOLS AND SUPPLIES

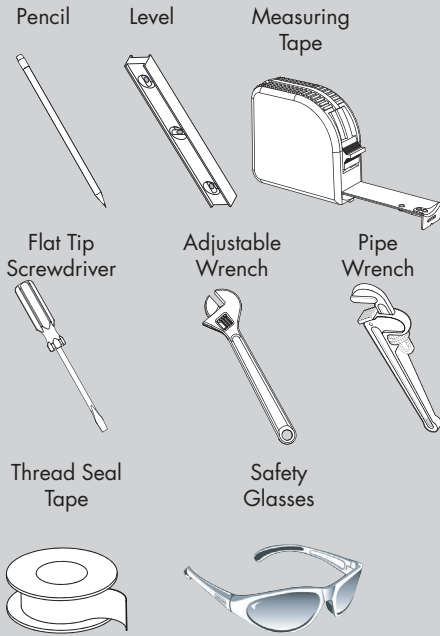

HELPFUL TOOLS & SUPPLIES:

- Lockable shut-off on the outlet supply if tempered water is supplied to one or more emergency fixtures.
- Lockable shut-off on the inlets/supplies.
- Unions on all connections to facilitate removal of valve.

IMPORTANT

- Compliance and conformity to local codes and ordinances is the responsibility of the installer.
- Valve should be accessible for testing, adjustment and maintenance in the installed position.
- Make sure that all water supply lines have been flushed and then completely turned off before beginning installation. Debris in supply lines can cause valves to malfunction.
- Ensure the mounting structure and mounting hardware can safely support the product in use.
- Do not over-tighten any connections or damage may occur.
- Be sure to read instructions thoroughly before beginning installation.

NOTE: Valve must be installed with check valves. If shut off valves are installed in the supply line for maintenance purposes, provisions shall be made to prevent unauthorized shut off.

IMPORTANT

SAFETY TIPS

Be sure to wear eye protection.

MAINTENANCE

See section "Testing the Mixing Valve".

WARRANTY

Warranty information can be found at: www.speakman.com

1A INSTALLING INTO CABINET

NOTE:

- If installing into Cabinet, see installation manual provided with Cabinet before proceeding.

Connect Supply Lines and Fixtures.

- Ensure incoming water supplies are turned OFF.
- Apply Thread Seal Tape to Inlet and Outlet pipe threads in a clockwise manner.
- Install the COLD Inlet pipe to the "C" Inlet on Valve.
- Install the HOT Inlet pipe to the "H" Inlet on Valve.
- Install Outlet connection to the Valve.
- Wrench tighten connections.

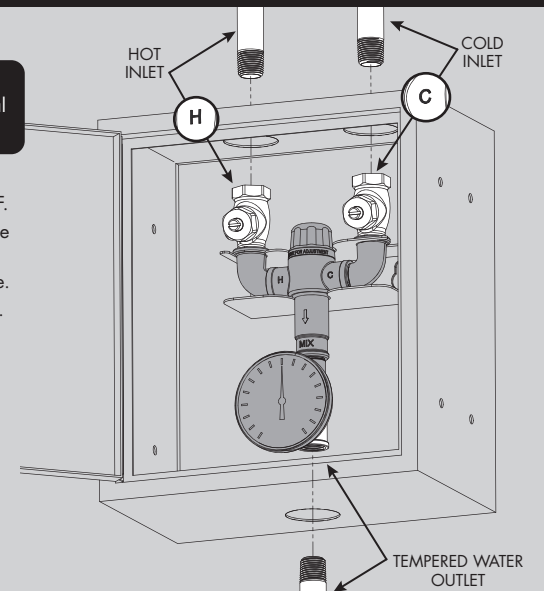
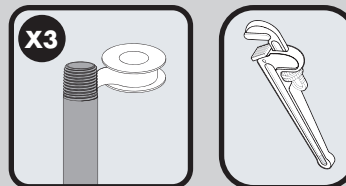

WARNING: The Valve will not function in the way it is intended to if Cold water supply pipe is connected to "H" Inlet on Valve and Hot water supply pipe is connected to "C" inlet on Valve.

1B INSTALLING WITHOUT CABINET

NOTE:

- If not installing into Cabinet, the Valve can be installed vertically with either the inlets at the top (as shown), or the inlets at the bottom depending on the location of inlet water supplies.

Connect Supply Lines and Fixtures.

- Ensure incoming water supplies are turned OFF.
- Apply Thread Seal Tape to Inlet and Outlet pipe threads in a clockwise manner.
- Install the COLD Inlet pipe to the "C" Inlet on Valve.
- Install the HOT Inlet pipe to the "H" Inlet on Valve.
- Install Outlet connection to the Valve.
- Wrench tighten connections.

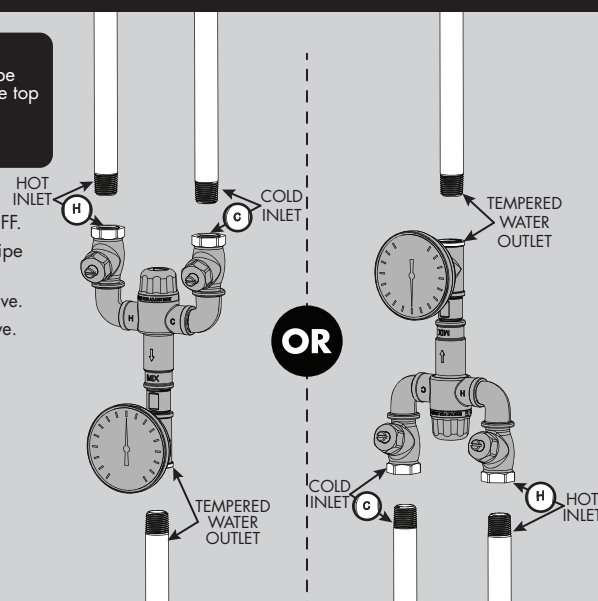
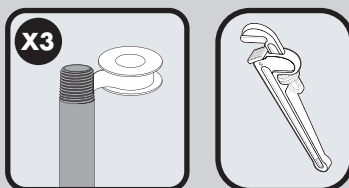

WARNING: The Valve will not function in the way it is intended to if Cold water supply pipe is connected to "H" Inlet on Valve and Hot water supply pipe is connected to "C" inlet on Valve.

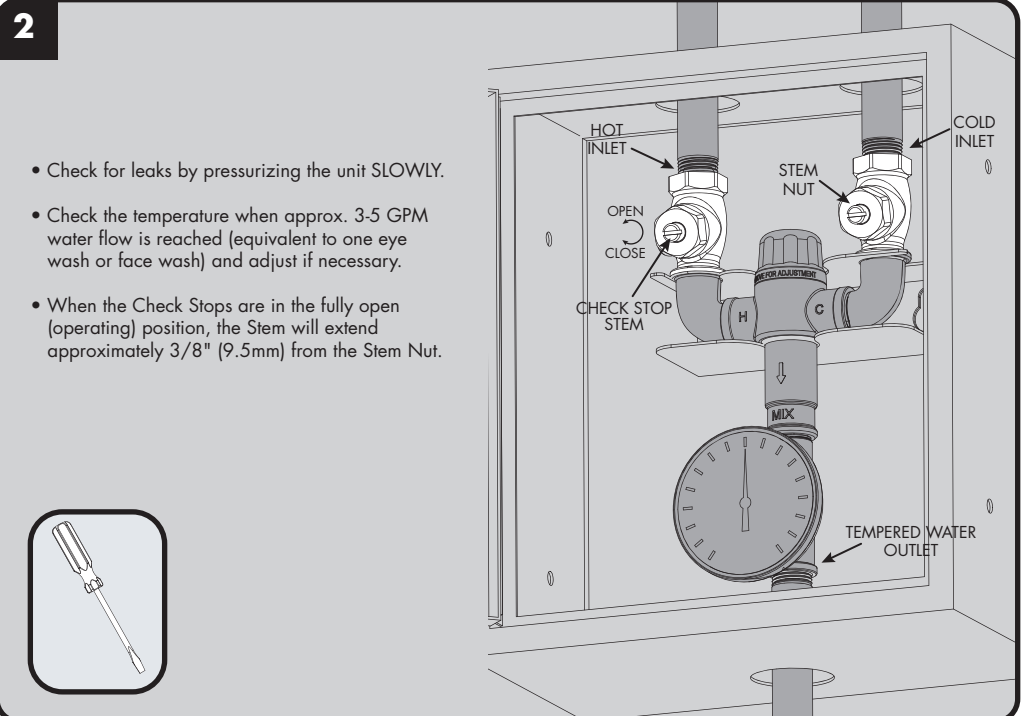

- Check for leaks by pressurizing the unit SLOWLY.
- Check the temperature when approx. 3-5 GPM water flow is reached (equivalent to one eye wash or face wash) and adjust if necessary.
- When the Check Stops are in the fully open (operating) position, the Stem will extend approximately 3/8" (9.5mm) from the Stem Nut.

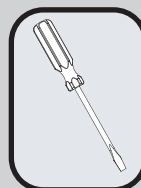

CAUTION

1: When maintaining and adjusting the Mixing Valve, all fixtures should be isolated from use. Speakman recommends that appropriate personnel shall work safely at all times and in a manner consistent with the OSHA Lock/Tag out standard, 29 CFR 1910.147 and other applicable standards.

2: When maintaining and adjusting the Mixing Valve, the delivered flushing fluid temperature shall be in the tepid range as per ANSI/ISEA Z358.1 Standard. In circumstances where chemical reaction is accelerated by flushing fluid temperature, a medical advisor should be consulted for the optimum temperature for each application.

3 SETTING THE MIXING VALVE

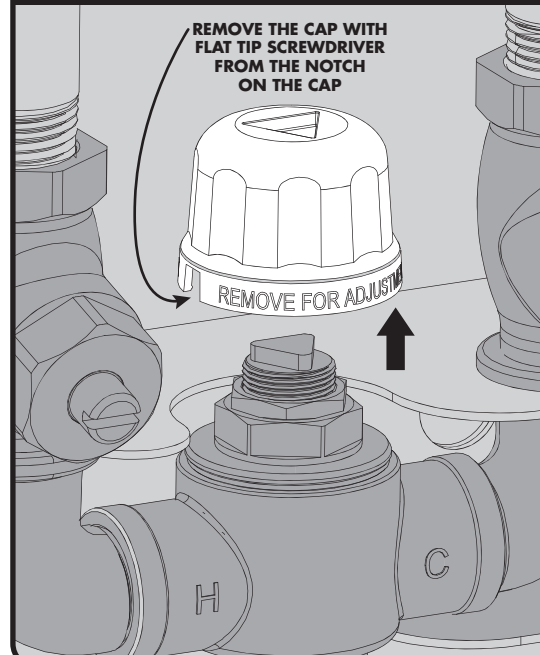

This Mixing Valve has been set at the factory to deliver 85 °F outlet flow. High temperature limit is set to 94 °F by design. Should the Valve require adjustment, or an application require a different set temperature, proceed as follows:

Adjust Temperature with Water Running

- Check the temperature when approximately 3-5 GPM water flow is reached (equivalent to one eye wash).
- Contact proper medical and safety authorities to determine the correct water temperature for the specific application (i.e., chemicals).
- Remove the Plastic Cap (White) from the Valve using a flat tip screwdriver.

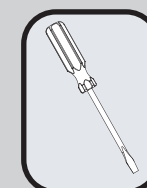

4

SETTING THE MIXING VALVE

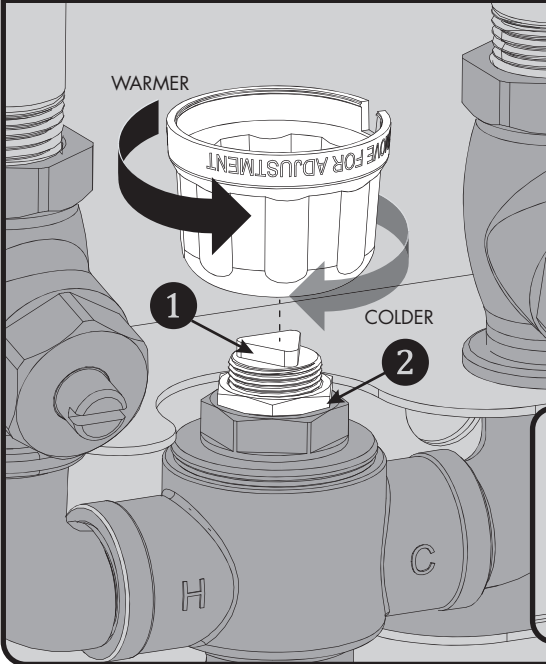

- Create a draw on the Mixing Valve by opening a downstream Eye Wash Fixture.
- Loosen, but do not remove the Locking Nut (2) using adjustable wrench. Invert Plastic Cap and align triangular recess in cap to the Adjuster Screw (1).
- Set the outlet temperature by turning the Adjuster Screw clockwise to reduce temperature, counterclockwise to increase temperature. Use the Dial Thermometer to check the outlet temperature.
- Tighten the Locking Nut to avoid inadvertent adjustment of outlet temperature.

5

TESTING THE MIXING VALVE

After installation, test the Mixing Valve and the Emergency Fixtures it serves for proper operation by following the steps below. Testing shall be performed weekly and logged to comply with applicable codes and standards.

Valve temperature test procedure is as follows:

1. Activate Eye Wash Fixture to observe and record the temperature of the Dial Thermometer. If the temperature of the Thermometer is not correct, readjust the Mixing Valve according to the section "Setting the Mixing Valve".
2. Observe the flow from the Emergency Fixture to ensure an adequate flow of water.

Hot Water Shut-off Test and Cold Water Shut-off Test Procedures:

1. Test Valve temperature as described in Step 1 and Step 2 above.
2. Shut off the hot water supply to the Mixing Valve. Observe the outlet flow from the Emergency Fixtures to ensure an adequate flow of cold water. A slight drop in flow may occur after shutting down the hot water supply to the Mixing Valve; however, the drop should be minimal and for a short duration.
3. Open the hot water supply to the Mixing Valve. The Thermometer should return to the set temperature.
4. Shut off the cold water supply to the Mixing Valve. The flow of water should shut down rapidly.
5. Open the cold water supply. The Thermometer should return to the set temperature.

The Thermometer should be checked at least every six months.

6

REPLACING THE THERMOSTATIC ELEMENT

The Thermostatic Element's replacement procedure is as follows:

1. Shut off the hot water supply and cold water supply to the Mixing Valve.
2. Remove the Plastic Cap and disassemble the Valve Cap.
3. Remove Thermostatic Element in conjunction with the Shuttle from the Valve Body. No special tools are required.
4. Inspect the Thermostatic Element.
If it feels slippery to the touch, then the Element has lost its wax and requires replacement. Disengage the Thermostatic Element from the Shuttle to replace.
If the Thermostatic Element feels normal to the touch, then it is in good condition and operable.
5. Verify that the stainless steel Piston moves freely up and down within the Element's body.

Note:

Gallon per minute ratings may vary depending upon incoming water temperatures and pressures. Hot and cold water inlet pressures must be equal.

Provisions shall be made to thermally isolate the valve.

STW-370 RECOMMENDED STANDARD INSTALLATION SYSTEM

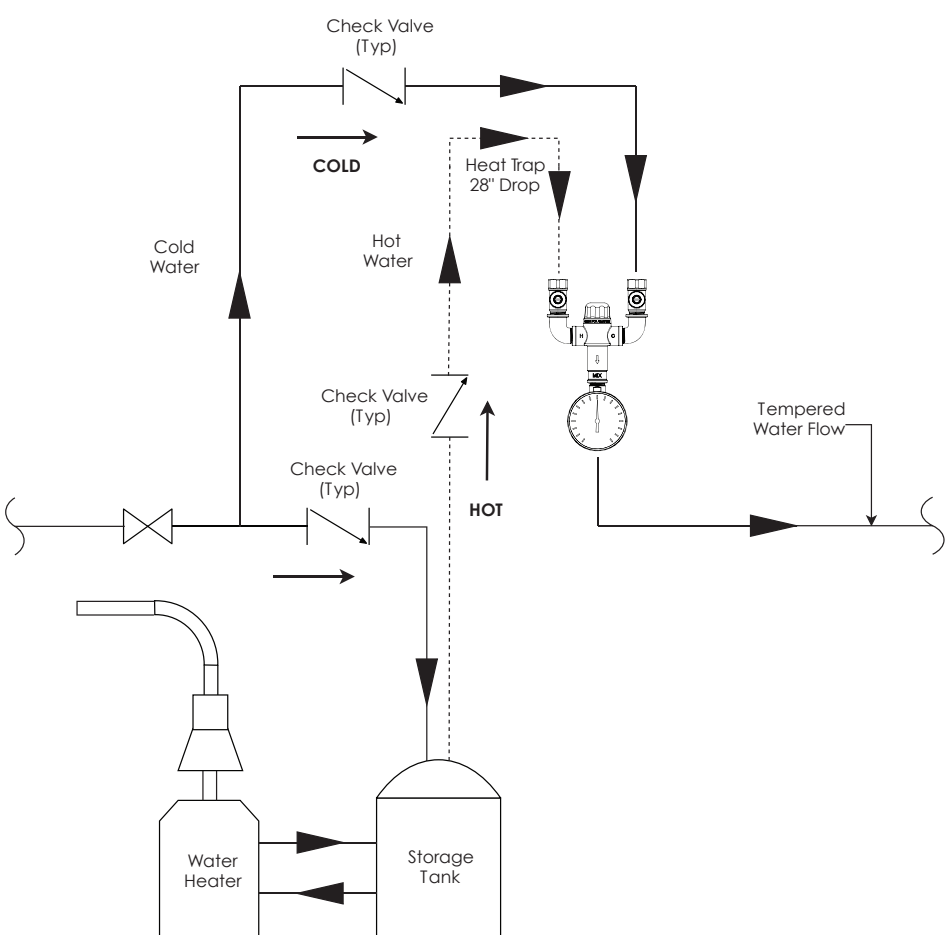

STW-370 RECOMMENDED RE-CIRCULATORY INSTALLATION SYSTEM

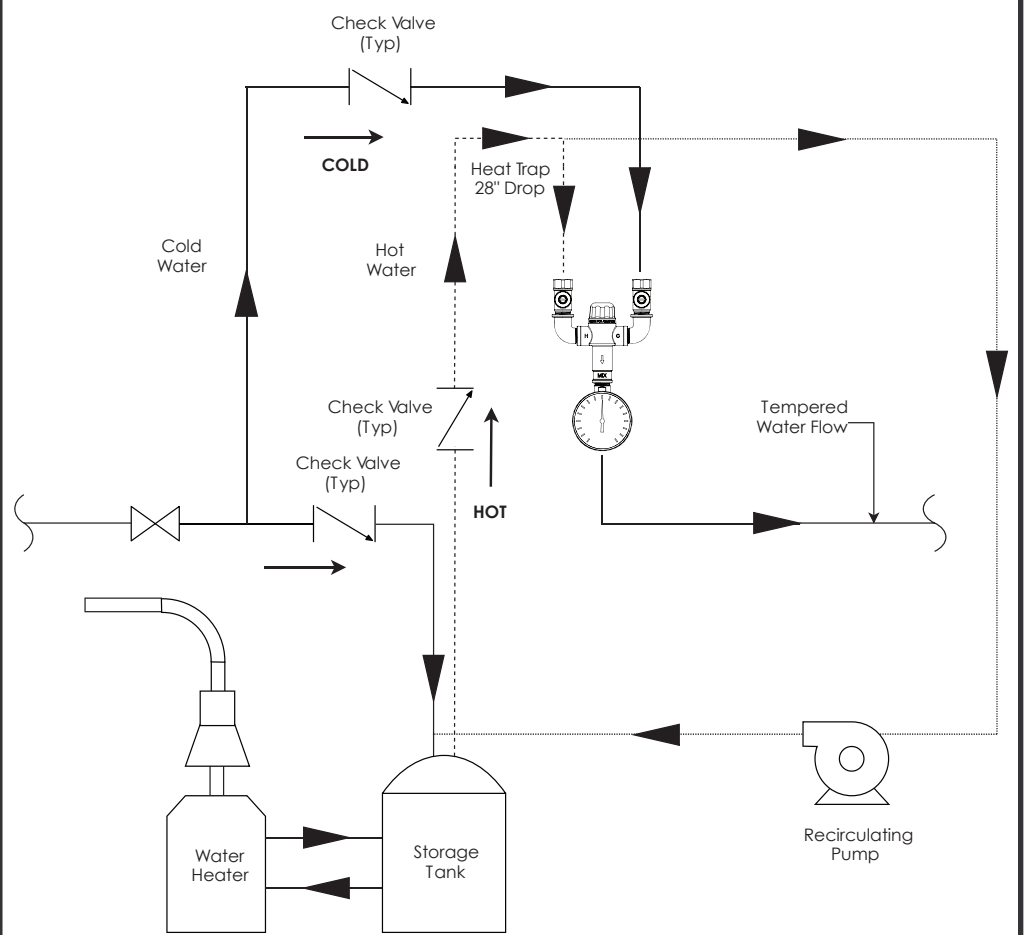

NOTES:

COMPLIANCE:

- ASSE 1071 & cUPC Certified
NSF 372 Certified
- Inlets: 1/2" NPT Female
 - Outlet: 1/2" NPT Female
 - Maximum Working Pressure: 125 psi (861.9 kPa)
 - Rated flow at 30 psi (206.9 kPa) differential pressure: 9.7 GPM (36.8 L/min)
 - Rated cold water by-pass flow at 30 psi (206.9 kPa) differential pressure: 5.2 GPM (19.7 L/min)
 - Minimum flow rate: 1.5 GPM (5.7 L/min)
 - Maximum flow rate with cold water shut-off: 0.3 GPM (1.2 L/min)
 - Hot Water Inlet Temperature Range: 120 °F – 180 °F
 - Cold Water Inlet Temperature Range: 40 °F – 70 °F
 - Outlet Water Temperature Range: 65 °F – 95 °F
 - Minimum Temperature Differential (cold water supply to valve set point): 10 °F
- Contractor to supply necessary inlet connections.

FLOW CAPACITY OF STW-370

PRESSURE DROP,	psi (bar)	5 (0.4)	10 (0.7)	15 (1.0)	20 (1.4)	30 (2.1)	40 (2.8)	45 (3.1)
TEMPERED FLOW,	GPM (L/min)	3.6 (13.6)	5.8 (22.0)	7.2 (27.3)	8.2 (31.1)	9.7 (36.8)	11.3 (42.8)	12.2 (46.2)
COLD WATER BYPASS,	GPM (L/min)	1.8 (6.8)	2.8 (10.6)	3.6 (13.6)	4.2 (15.9)	5.2 (19.7)	6.0 (22.7)	6.4 (24.3)

DIMENSIONS SUBJECT TO CHANGE WITHOUT NOTICE.

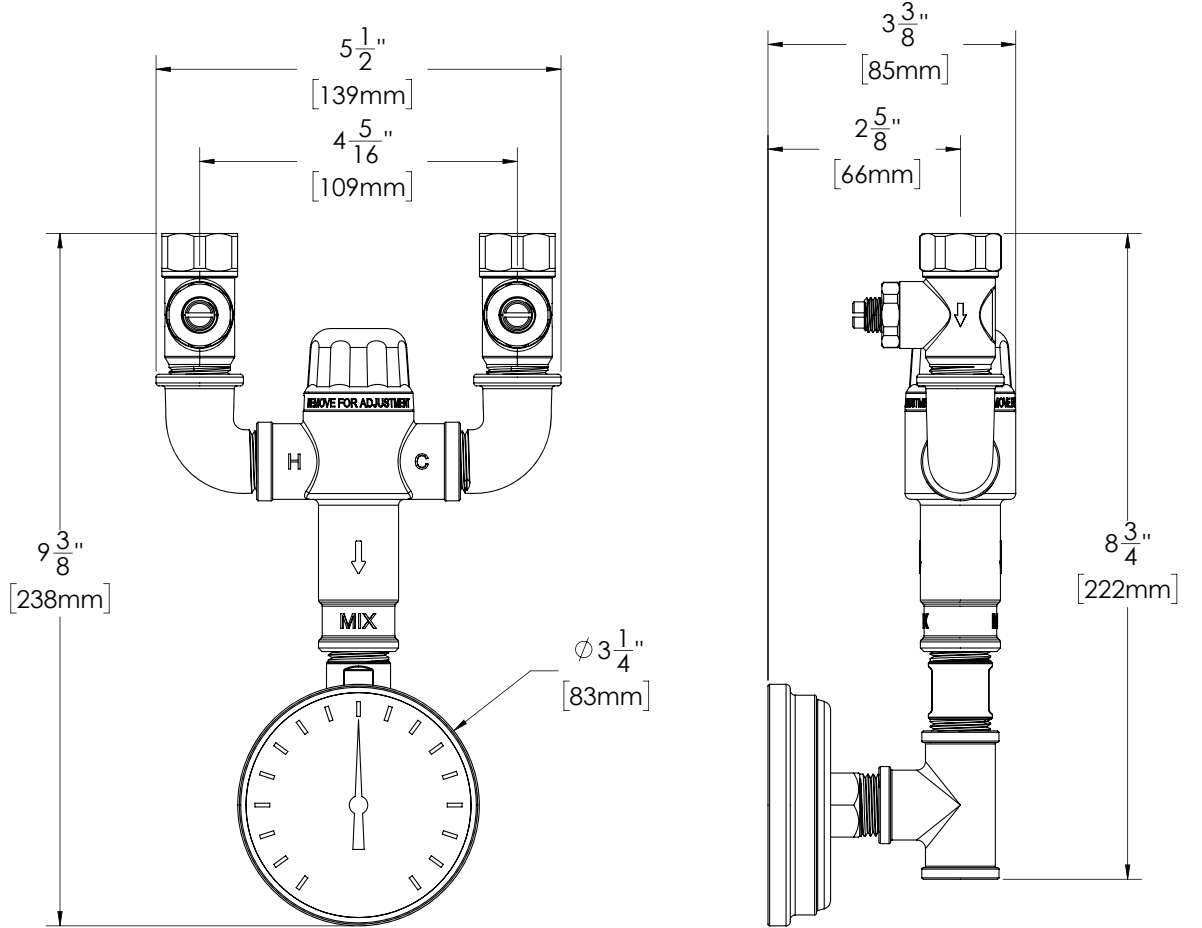

STW-370 REPAIR PARTS

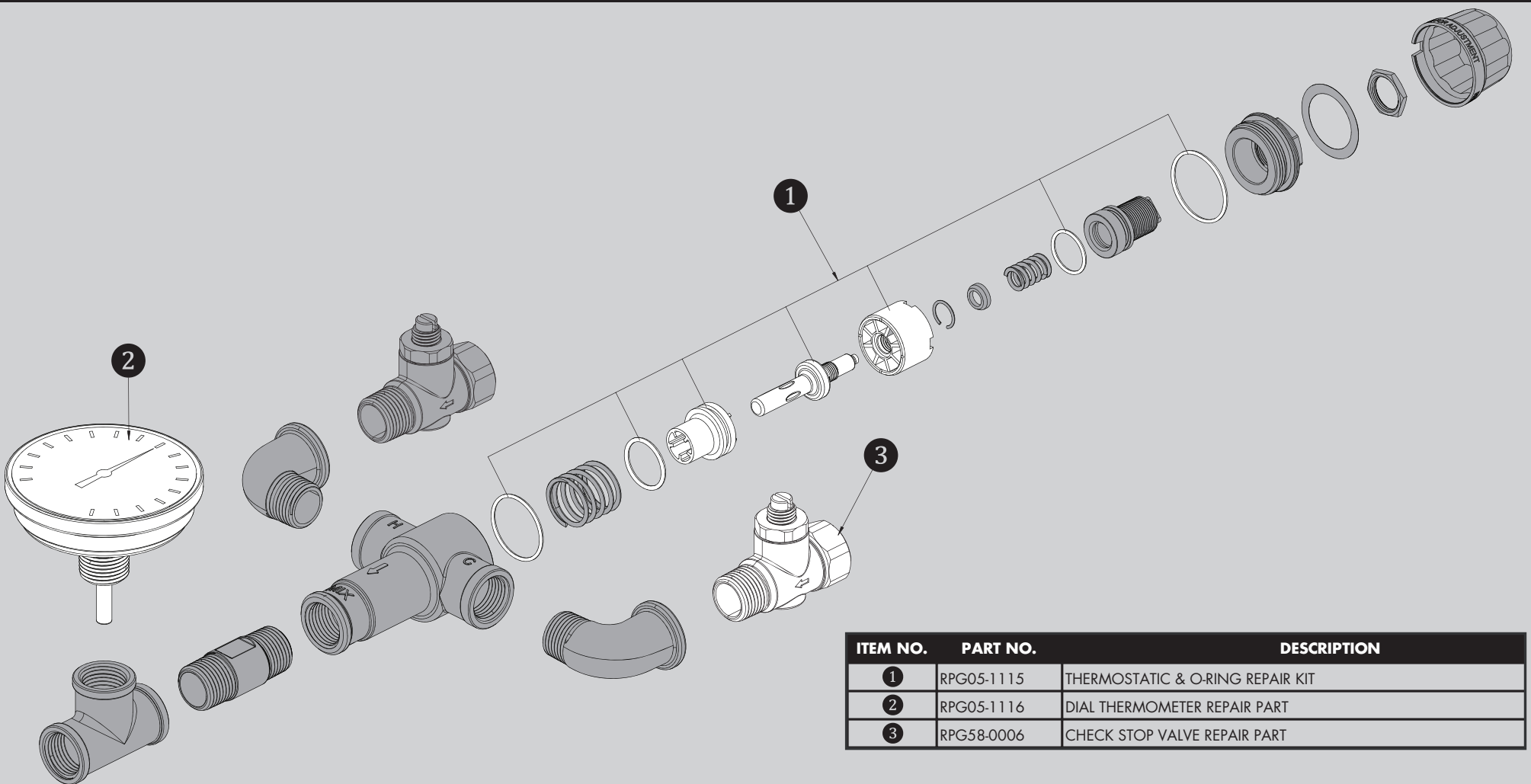

ITEM NO.	PART NO.	DESCRIPTION
1	RPG05-1115	THERMOSTATIC & O-RING REPAIR KIT
2	RPG05-1116	DIAL THERMOMETER REPAIR PART
3	RPG58-0006	CHECK STOP VALVE REPAIR PART