

SPECIFICATIONS

FIGURE 7709 PIPING PRODUCTS



PIPE SUPPORTS

Like all of the FNW block supports, Figure 7709 is perfect for supporting natural gas and refrigeration piping systems, cable tray, electrical conduit, multiple lines, HVAC equipment and many other applications.

MADE IN THE
USA

FEATURES

- Provides a longer mounting surface with strut lengths up to 46-3/8"
- UV resistant and suitable for installation on most types of roofing material or other flat surfaces
- Roof supports come pre-assembled
- 2-7/16" H-122 Pre-galvanized steel channel
- 100% Recycled rubber
- Made in the USA

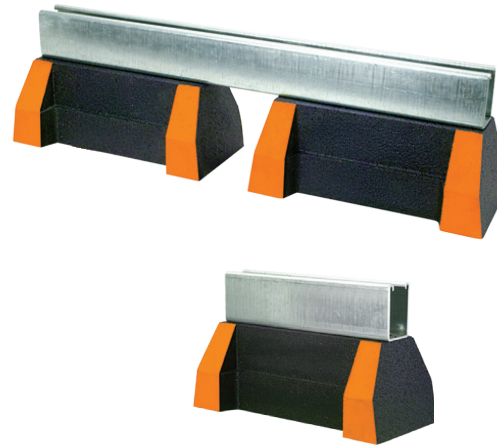

PRODUCT SPECIFICATIONS

Material

- 100% Recycled rubber
- All 4 corners coated with ANSI #2535.1-1998 orange
- FNW channels are produced from prime structural steel covered by the following specifications.
- Pre-galvanized steel ASTM A-653

Testing

Rooftop supports have been tested by an accredited independent laboratory to the following:

- ASTM D575 Method B-Modified-Compression/deflection
- ASTM D1171 Modified-Ozone resistance freeze/thaw
- Environmental simulation

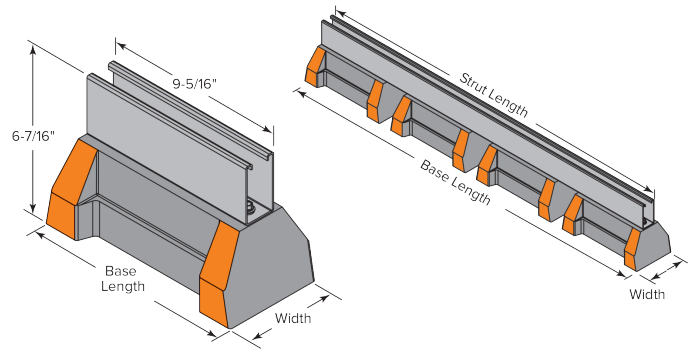

Model No.	Height		Width		No. of Bases Required	Strut Length		Base Length		Weight		Uniform Load Capacity (lbs)*	
	in.	mm	in.	mm		in.	mm	in.	mm	lbs	kg	lbs	kN
FNW770910	6-7/16	165	5	127	1	9.312	237	10-7/8	276	6.69	3.03	2500*	11.12*
FNW770924					2	22.375	568	24	610	14.13	6.41	5000*	22.24*
FNW770936					3	34.375	873	36	914	21.35	9.68	7500*	33.36*
FNW770948					4	46.375	1178	48	1219	28.58	12.96	10000*	44.48*

* This load is only for the capacity of the components in this assembly. Please consult roofing manufacturer or engineer for roof load capacity.