

# INSTALLATION MANUAL

## MODULAR VARIABLE SPEED AIR HANDLERS

MODELS: MV



### LIST OF SECTIONS

GENERAL	1	REQUIRED CONTROL SET-UP	6
SAFETY	1	LINE POWER CONNECTIONS	7
UNIT INSTALLATION	2	AIRFLOW AND COMFORT SETTING SELECTION	8
ELECTRIC HEATER INSTALLATION	5	UNIT DATA	9
LOW VOLTAGE CONTROL CONNECTIONS	6	MAINTENANCE	13

### LIST OF FIGURES

Typical Installation with MC or FC Evaporator Coil	3	Control Board	5
Coil and Air Handler Attachment Details	3	Line Power Connections	8
Dimensions & Duct Connection Dimensions	4	Cooling Models with and without Electric Heat Wiring	13
Typical Horizontal Installation	5	Two-Stage Heat Pump Wiring	13

### LIST OF TABLES

Dimensions	4	Electrical Data - (For Single Source Power Supply) - Copper Wire 1 Ø - 208/230-1-60	10
Low Voltage Connections	6	Electrical Data - (For Multi-Source Power Supply) - Copper Wire 1 Ø - 208/230-1-60	11
Fault Codes	7	Electrical Data - 208/230-3-60	11
Heat Relays	7	Electrical Data - (For Single Source Power Supply) - Copper Wire - 208/230-3-60	11
Cooling and Heat Pump Airflow Selection	8	Electrical Data - (For Multi-Source Power Supply) - Copper Wire - 208/230-3-60	11
Electric Heat Airflow	8	Cooling Air Flow Data	12
Comfort Setting Selection	9	Heating Air Flow Data	12
Physical and Electrical Data - Cooling Only (60 Hz)	9		
Electrical Data - Cooling Only (60 Hz)	9		
Conversion Table	9		
Electrical Data - 1 Ø - 208/230-1-60	10		

## SECTION I: GENERAL

This modular air handler provides the flexibility for installation in any upflow, downflow, or horizontal application. These versatile models may be used for cooling or heat pump operation with or without electric heat.

A BRAND LABEL (available from Distribution) may be applied to the center of the blower access panel.

The unit can be positioned for bottom return air in the upflow position, top return air in the downflow position, and right or left return in the horizontal position.

Top and side power wiring and control wiring, accessible screw terminals for control wiring and easy to install electric heaters all combine to make the installation easy, and minimize installation cost.

## SECTION II: SAFETY



This is a safety alert symbol. When you see this symbol on labels or in manuals, be alert to the potential for personal injury.

Understand and pay particular attention to the signal words **DANGER**, **WARNING**, or **CAUTION**.

**DANGER** indicates an **imminently** hazardous situation, which, if not avoided, **will result in death or serious injury**.

**WARNING** indicates a **potentially** hazardous situation, which, if not avoided, **could result in death or serious injury**.

**CAUTION** indicates a potentially hazardous situation, which, if not avoided **may result in minor or moderate injury**. It is also used to alert against unsafe practices and hazards involving only property damage.

### WARNING

*Improper installation may create a condition where the operation of the product could cause personal injury or property damage. Improper installation, adjustment, alteration, service or maintenance can cause injury or property damage. Refer to this manual for assistance or for additional information, consult a qualified contractor, installer or service agency.*

### CAUTION

*This product must be installed in strict compliance with the installation instructions and any applicable local, state, and national codes including, but not limited to building, electrical, and mechanical codes.*

### WARNING

**FIRE OR ELECTRICAL HAZARD**  
*Failure to follow the safety warnings exactly could result in serious injury, death or property damage. A fire or electrical hazard may result causing property damage, personal injury or loss of life.*

1. Install this air handler only in a location and position as specified in SECTION III of these instructions.
2. Always install the air handler to operate within the air handler's intended maximum outlet air temperature. Only connect the air handler to a duct system which has an external static pressure within the allowable range, as specified on the air handler rating plate.
3. When an air handler is installed so that supply ducts carry air circulated by the air handler to areas outside the space containing the air handler, the return air shall also be handled by duct(s) sealed to the air handler casing and terminating outside the space containing the air handler.
4. The air handler is not to be used for temporary heating of buildings or structures under construction.
5. The size of the unit should be based on an acceptable heat loss or gain calculation for the structure. ACCA, Manual J or other approved methods may be used.

### SAFETY REQUIREMENTS

1. This air handler should be installed in accordance with all national and local building/safety codes and requirements, local plumbing or wastewater codes, and other applicable codes.
2. Refer to the unit rating plate for the air handler model number, and then see the dimensions page of this instruction for supply air plenum dimensions in Figure 3. The plenum must be installed according to the instructions.
3. Provide clearances from combustible materials as listed under Clearances to Combustibles.
4. Provide clearances for servicing ensuring that service access is allowed for electric heaters and blower.
5. Failure to carefully read and follow all instructions in this manual can result in air handler malfunction, death, personal injury and/or property damage.
6. Check the rating plate and power supply to be sure that the electrical characteristics match.
7. Air handler shall be installed so the electrical components are protected from water.
8. Installing and servicing heating/cooling equipment can be hazardous due to the electrical components. Only trained and qualified personnel should install, repair, or service heating/cooling equipment. Untrained service personnel can perform basic maintenance functions such as cleaning and replacing the air filters. When working on heating/cooling equipment, observe precautions in the manuals and on the labels attached to the unit and other safety precautions that may apply.
9. These instructions cover minimum requirements and conform to existing national standards and safety codes. In some instances these instructions exceed certain local codes and ordinances, especially those who have not kept up with changing residential and non-HUD modular home construction practices. These instructions are required as a minimum for a safe installation.

### INSPECTION

As soon as a unit is received, it should be inspected for possible damage during transit. If damage is evident, the extent of the damage should be noted on the carrier's freight bill. A separate request for inspection by the carrier's agent should be made in writing. Also, before installation the unit should be checked for screws or bolts, which may have loosened in transit. There are no shipping or spacer brackets which need to be removed.

Also check to be sure all accessories such as heater kits, suspension kits, and coils are available. Installation of these accessories or field conversion of the unit should be accomplished before setting the unit in place or connecting any wiring, electric heat, ducts or piping.

### LIMITATIONS

These units must be wired and installed in accordance with all national and local safety codes.

Voltage limits are as follows:

Air Handler Voltage	Voltage code	<sup>1</sup> Normal Operating Voltage Range
208/230-1-60	21	187-253

1. Rated in accordance with ARI Standard 110, utilization range "A".

Airflow must be within the minimum and maximum limits approved for electric heat, evaporator coils and outdoor units.

Entering Air Temperature Limits			
Wet Bulb Temp. °F		Dry Bulb Temp. °F	
Min.	Max.	Min.	Max.
57	72	65	95

## SECTION III: UNIT INSTALLATION

### CLEARANCES

Clearances must be taken into consideration, and provided for as follows:

1. Refrigerant piping and connections - minimum 12" recommended.
2. Maintenance and servicing access - minimum 36" from front of unit recommended for blower motor / coil replacement.
3. Condensate drain lines routed to clear filter and panel access.
4. Filter removal - minimum 36" recommended.
5. A combustible floor base accessory is available for downflow applications of this unit, if required by local code.

### LOCATION

Location is usually predetermined. Check with owner's or dealer's installation plans. If location has not been decided, consider the following in choosing a suitable location:

1. Select a location with adequate structural support, space for service access, clearance for air return and supply duct connections.
2. Use hanging brackets to wall mount unit as shown.
3. Normal operating sound levels may be objectionable if the air handler is placed directly over some rooms such as bedrooms, study, etc.
4. Select a location that will permit installation of condensate line to an open drain or outdoors allowing condensate to drain away from structure.
5. When an evaporator coil is installed in an attic or above a finished ceiling, an auxiliary drain pan should be provided under the air handler as is specified by most local building codes.
6. Proper electrical supply must be available.

**NOTE:** In severe high humidity, high temperature indoor unit environments, seal completely with adequate fiberglass insulation using vapor barrier on the outside.

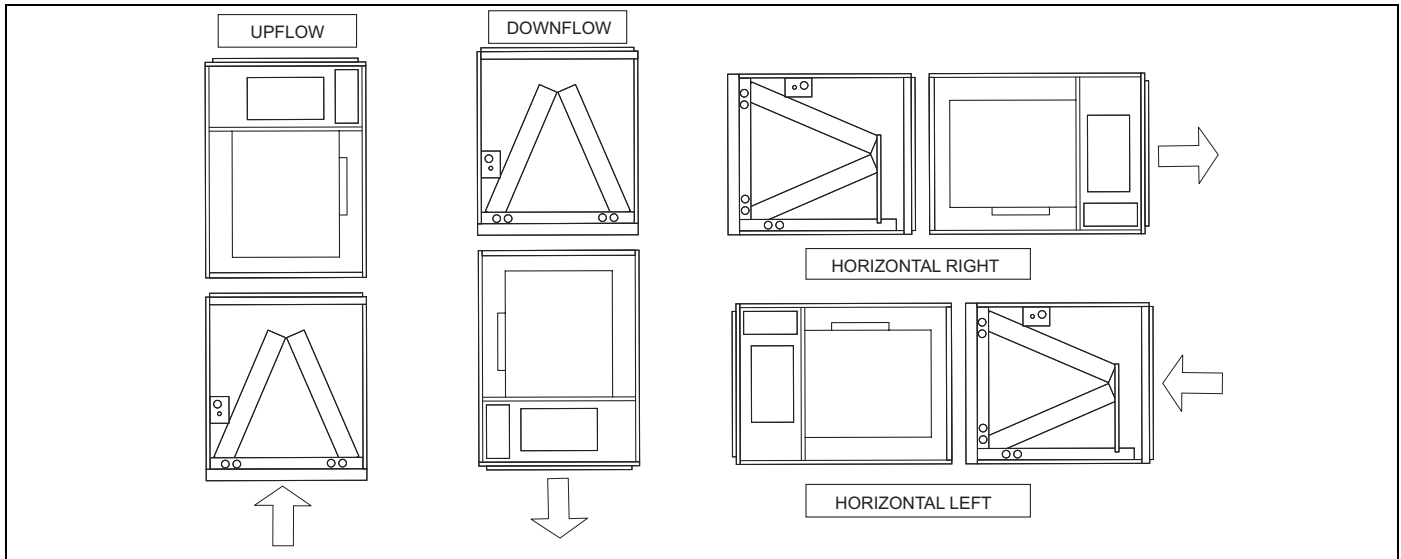
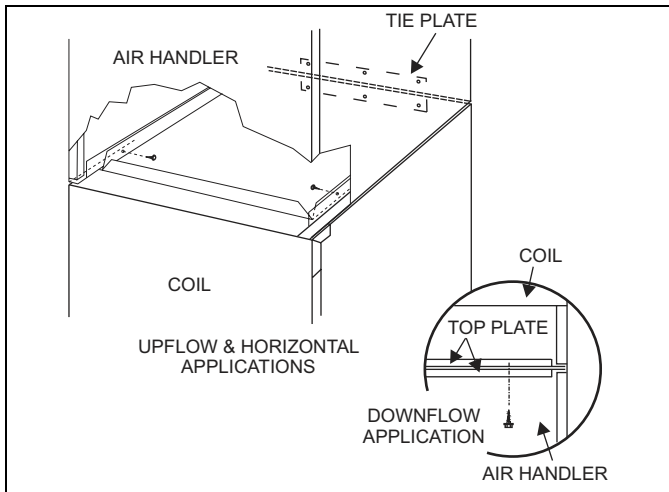

**FIGURE 1:** Typical Installation with MC or FC Evaporator Coil (MC required for horizontal applications)

### DOWNFLOW AND HORIZONTAL CONVERSION

These air handler units are supplied ready to be installed in a upflow, downflow and left or right hand horizontal position.

If the unit is to be installed with an evaporator coil, refer to Figure 1 for unit positioning information.



**FIGURE 2:** Coil and Air Handler Attachment Details

### AIR HANDLER AND COIL UPFLOW AND HORIZONTAL INSTRUCTIONS

1. Apply neoprene gasket to top of coil.
  2. Position blower casing over coil opening.
- NOTE:** Tie plate and screws are provided with coils.
3. Attach tie plate to casings of air handler and coil using screws.
  4. Remove blower access panel.
  5. Fasten duct flanges of coil to duct flanges of air handler with screws. See Figure 2.
  6. Secure base of air handler to top of coil using screws.
  7. Complete electrical and blower speed connections as outlined in other sections of this document.
  8. Reposition and replace blower access panel.

### AIR HANDLER AND COIL DOWNFLOW INSTRUCTIONS

1. Position blower casing over duct connection and secure such that the supply air end of the blower is down.
2. Apply neoprene gasket to return-air side of air handler.
3. Place coil casing over blower return opening.

**NOTE:** Tie plate and screws are provided with coils.

4. Attach tie plate to casings of air handler and coil using screws.
5. Remove blower access panel and coil filter door.
6. Fasten duct flanges of coil to base of air handler with screws. See Figure 2.
7. Secure base of air handler to base of coil using screws.
8. Complete electrical and blower speed connections as outlined in other sections of this document.
9. Reposition and replace blower access panel.

### CAUTION

*Blowers with an electric heater kit may require a non-combustible floor base if installing on a combustible floor. See instructions for 1FB1817, 1FB1821, and 1FB1824, and local codes.*

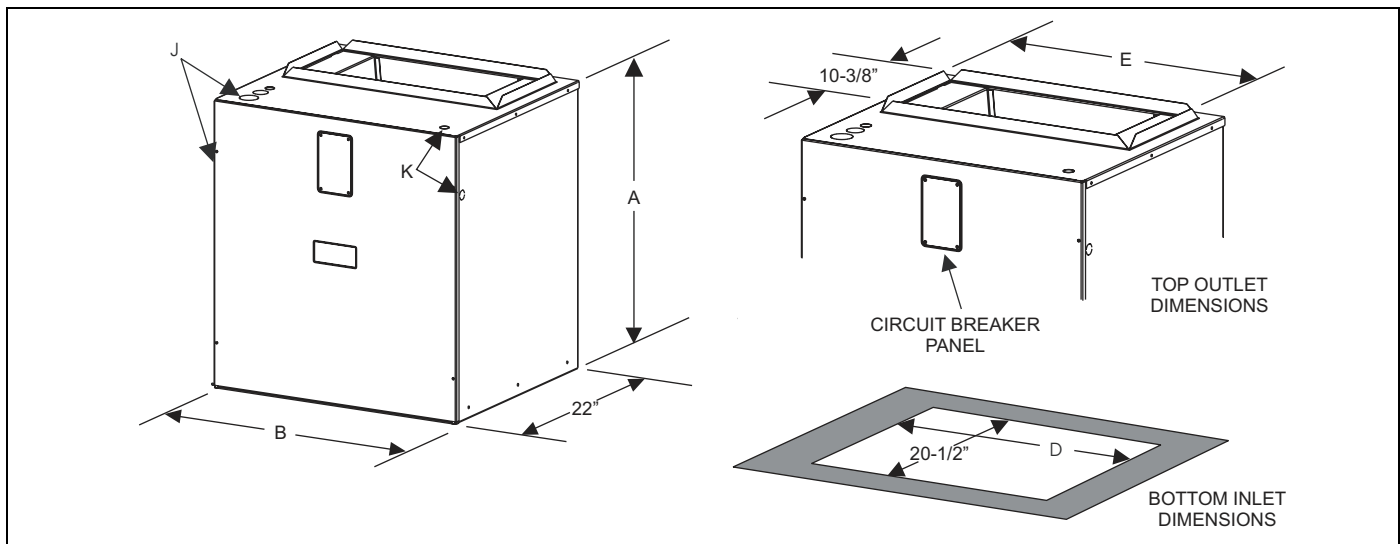

**FIGURE 3:** Dimensions & Duct Connection Dimensions

**TABLE 1:** Dimensions

Models MV	Dimensions				Wiring Knockouts <sup>1</sup>	
	A	B	D	E	J	K
	Height	Width			Power	Control
12B	25	17-1/2	16-1/2	14-19/32	7/8" (1/2") 1 3/8" (1") 1 23/32" (1 1/4")	7/8" (1/2")
12D		24-1/2	23-1/2	21-19/32		
16C		21	20	18-3/32		
20D		24-1/2	23-1/2	21-19/32		

1. Actual size (Conduit size).

**DUCT CONNECTORS**

**WARNING**

Use 1/2" screws to connect ductwork to bottom of unit. Longer screws will pierce the drain pan and cause leakage. If pilot holes are drilled, drill only through field duct and unit bottom flange.

Air supply and return may be handled in one of several ways best suited to the installation. See Figure 3 for dimensions for duct inlet and outlet connections.

The vast majority of problems encountered with combination heating and cooling systems can be linked to improperly designed or installed duct systems. It is therefore highly important to the success of an installation that the duct system be properly designed and installed.

Use flexible duct collars to minimize the transmission of vibration/noise into the conditioned space. If electric heat is used, non-flammable material must be used.

Where return air duct is short, or where sound may be a problem, sound absorbing glass fiber should be used inside the duct. Insulation of duct work is a must where it runs through an unheated space during the heating season or through an uncooled space during the cooling season. The use of a vapor barrier is recommended to prevent absorption of moisture from the surrounding air into the insulation.

The supply air duct should be properly sized by use of a transition to match unit opening. All ducts should be suspended using flexible hangers and never fastened directly to the structure. This unit is not designed for non-ducted (freeblow) applications. Size outlet plenum or transition to discharge opening sizes shown in Figure 3.

Duct work should be fabricated and installed in accordance with local and/or national codes. This includes the standards of the National Fire Protection Association for Installation of Air-Conditioning and Ventilating Systems, NFPA No. 90B.

**AIR FILTERS**

Air filters and filter racks must be field supplied

**CAUTION**

Equipment should never be operated without filters.

**SUSPENSION KITS**

A suspension kit is available. Models 1BH0601 (unit size 018-060) is designed specifically for the units contained in this instruction (upflow application only). For installation of these accessory kits, see the instructions packed with the kit.

### HORIZONTAL SUSPENSION

For suspension of these units in horizontal applications, it is recommended to use angle steel support brackets with threaded rods, supporting the units from the bottom, at the locations shown in Figure 4.

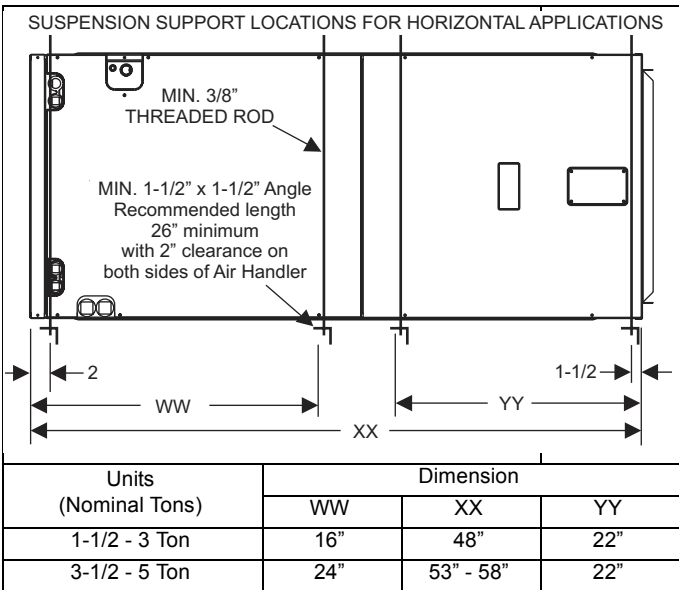

FIGURE 4: Typical Horizontal Installation

### SECTION IV: ELECTRIC HEATER INSTALLATION

If the air handler requires electric heat, install the electric heat kit according to the installation instructions included with the kit. After installing the kit, mark the air handler nameplate to designate the heater kit that was installed. If no heater is installed, mark the name plate appropriately to indicate that no heat kit is installed.

The HEAT ENABLE jumper (See Figure 5) must be moved to the HEAT position to enable operation of the heater.

Use only 4HK heater kits, as listed on Air Handler name plate and in these Instructions. Use data from Tables 11 through 15 for information on required minimum motor speed tap to be used for heating operation, maximum over-current protection device required and minimum electrical supply wiring size required for listed combination of Air Handler and Heater Kit.

For Upflow, Downflow and Horizontal right hand applications the kits can be installed without modification.

Field modification is required for Horizontal left-hand airflow application only. Follow instructions with heater for modification.

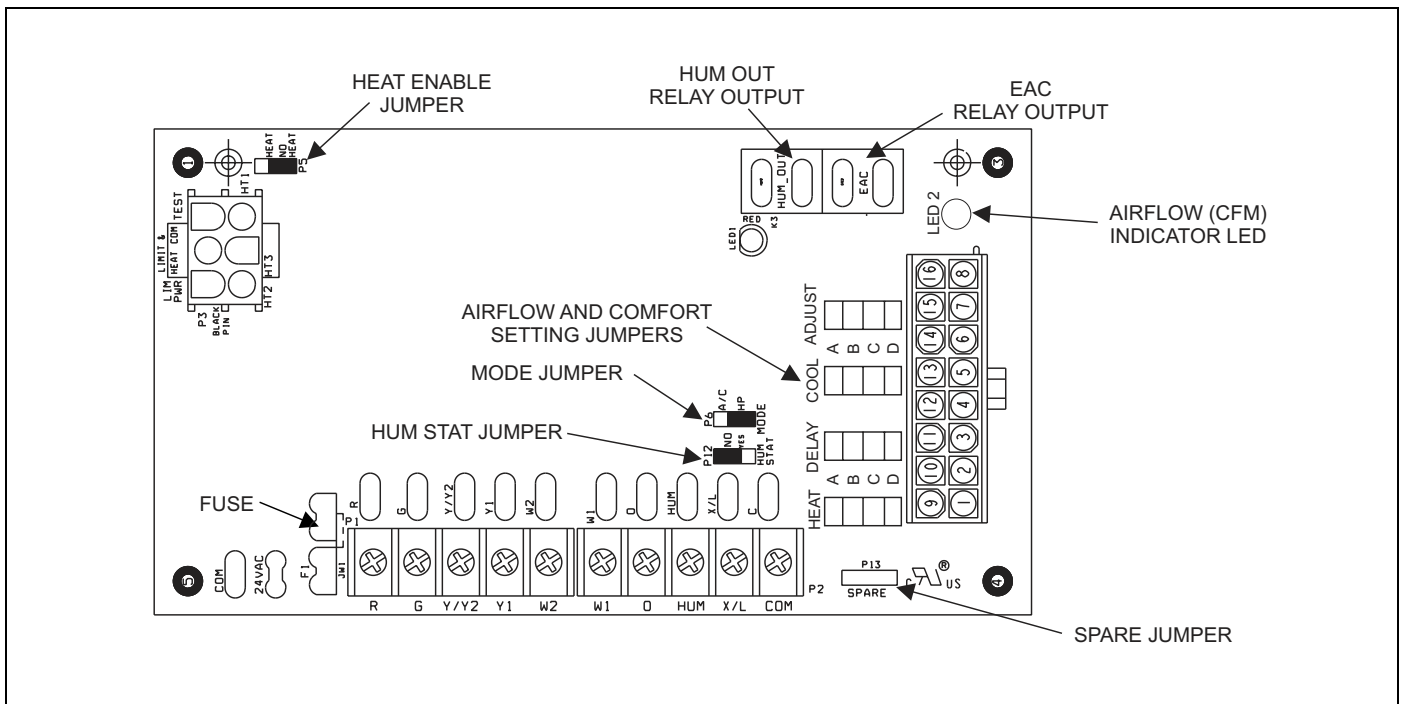

FIGURE 5: Control Board

## SECTION V: LOW VOLTAGE CONTROL CONNECTIONS

The 24 volt power supply is provided by an internally wired low voltage transformer which is standard on all models. However, if the unit is connected to a 208 volt power supply, the low voltage transformer must be rewired to the 208 volt tap. See the unit wiring label.

Field supplied low voltage wiring can exit the unit on the top right hand corner or the right hand side panel. Refer to Figure 3.

Remove desired knockout and pierce foil faced insulation to allow wiring to pass through. Use as small of a hole as possible to minimize air leakage.

Install a 7/8" plastic bushing in the selected hole and keep low voltage wiring as short as possible inside the control box.

To further minimize air leakage, seal the wiring entry point at the outside of the unit.

The field wiring is to be connected at the screw terminals of the control board. Refer to Figures 7 and 8.

**NOTE:** All wiring must comply with local and national electrical code requirements. Read and heed all unit caution labels.

**NOTE:** It is possible to vary the amount of electric heat turned on during the defrost cycle of a heat pump. Standard wiring will only bring on the first stage of electric heat during defrost. See Heat Output and Limit Connections and Table 4 for additional information on heat during defrost cycle.

**TABLE 2:** Low Voltage Connections

Terminal	Signal	Comment
R	24 VAC power (fused)	
G	Continuous Fan operation	
Y/Y2	Second or full stage compressor operation	
Y1	First stage compressor operation	Not used with outdoor units having one stage compressors.
W2	Second stage heat operation	
W1	First stage heat operation	
O	Reversing valve operation	24 VAC will be present at this terminal when the MODE jumper is in the AC position. This is normal.
HUM	Humidity switch input	24 VAC will be present at this terminal when the HUM STAT jumper is in the NO position. This is normal.
X/L	Connection point for heat pump fault indicator	This terminal is a connection point only and does not affect air handler control operation.
COM	24 VAC common	

The low voltage connections may be connected to the screw terminals or the quick connect terminals. The screw terminals and the quick connect terminals are physically connected on the control board.

### HUMIDITY SWITCH INPUT

The air handler control is designed to work with a humidity control that closes when the humidity is below the set-point. The control is open when the humidity is above the set-point. This humidity control may be referred to as a humidistat or a dehumidistat.

The humidity switch controls both humidification and de-humidification operation of the control. The control provides humidification using the HUM OUT relay output and de-humidification by lowering the blower speed. This is accomplished using the LOW FAN output and a field installed two-speed fan relay kit for non-variable speed models and the de-humidification input of the motor for variable speed models. The humidity switch should be connected to the R and HUM terminals of the control. See Figures 7 and 8.

## SECTION VI: REQUIRED CONTROL SET-UP

**IMPORTANT:** The following steps must be taken at the time of installation to insure proper system operation.

1. Consult system wiring diagram to determine proper thermostat wiring for your system.
2. If heat kit is installed, change HEAT ENABLE jumper from NO HEAT to HEAT position.
3. If a humidistat is installed, change HUM STAT jumper from NO to YES.
4. Set the MODE jumper to A/C (Air Conditioner) or HP (Heat Pump) position depending on the outdoor unit included with the system.
5. Set airflow and comfort setting jumper to proper positions.

## FUNCTIONALITY AND OPERATION

### Jumper Positions

#### Heat Enable Jumper

The HEAT ENABLE jumper configures the control for heat kit operation. The jumper must be in the HEAT position if a heat kit is installed with the air handler.

With the jumper in the NO HEAT position, the control will not energize the heat relay outputs or sense the limit switch input.

If the jumper is not present, the control will operate as if the jumper is in the HEAT position. If the jumper is not present and a heat kit is not present, the control will sense an open limit condition and the blower will run continuously.

#### Hum Stat Jumper

The HUM STAT jumper configures the control to monitor the humidity switch input. With the jumper in the NO position, the control will energize the HUM terminal with 24 VAC continually. With the jumper in the YES position, the control will monitor the HUM input to control the HUM OUT output to control an external humidifier.

If the jumper is not present, the control will operate as if the jumper is in the YES position.

#### Mode Jumper

The MODE jumper configures the control to operate properly with an air conditioner (AC position) or heat pump (HP position). With the jumper in the AC position, the control will energize the O terminal with 24 VAC continually. With the jumper in the HP position, the O input signal is received from the room thermostat.

If the jumper is not present, the control will operate as if the jumper is in the HP position.

#### SPARE Jumper

The control includes a spare jumper that can be used if a jumper is lost. The SPARE jumper does not have any effect on the operation of the control.

#### Airflow and Comfort Setting Jumpers

See separate section.

#### Status and Fault Codes

The control includes an LED that displays status and fault codes. These codes are shown in Table 3. The control will display the fault codes until power is removed from the control or the fault condition is no longer present.

**TABLE 3:** Fault Codes

Fault or Status Condition	LED1 (RED) Flash Code
<b>Status</b>	
No power to control	OFF
Normal operation	2s ON / 2s OFF
Control in test mode	Rapid Flash
Control failure	ON
<b>Limit Faults</b>	
Limit switch currently open (not in lockout)	1
Multiple limit openings with no call for heat	2
Multiple limit openings during one call for heat	3
Single long duration limit opening	4
Multiple long duration limit openings	5
Fan failure	6
<b>Wiring Related Faults</b>	
Simultaneous call for heating and cooling	7
<b>Internal Control Faults</b>	
Control recovered from internal event	9

**External Relay Outputs**

The control includes two outputs to drive external relays having 24 VAC coils. The outputs have a maximum rating of 1.0 Amp pilot duty at 24 VAC.

**HUM OUT**

The HUM OUT output can be used to drive an external relay or solenoid (24 VAC coil) to control a humidifier. The output is energized when the HUM input is energized, the HUM STAT is in the YES position, and the control has a thermostat call for heating (heat pump or electric heat).

**EAC**

The EAC output can be used to drive an external relay (24 VAC coil) to control an electronic air cleaner. The output is energized whenever the blower relay on the control is energized.

**Heat Output and Limit Connections**

The control is connected to the heater relays and limit switch using the 6-pin connector. The relay outputs and the limit switch signal are 24 VDC.

The control energizes the heat relays and senses the limit switch input as shown in Table 4 when the HEAT ENABLE jumper is in the HEAT position.

**TABLE 4:** Heat Relays

Input	Heat Relay Output
W1	HT1
W2	HT1 and HT2
W1 and W2	HT1 and HT2 and HT3

The control energizes the first stage of electric heat immediately, the second stage 10 seconds after the call for second stage heat, and the third stage 20 seconds after the call for third stage heat.

Depending on the heat kit installed in the air handler, the control provides the flexibility to configure the amount of heat delivered with the first stage heating call. As an example, when the control's W1 input is connected to the room thermostat's first stage heat signal, a call for first stage heat will energize one heating element (HT1). If the control's W2 input is connected to the room thermostat's first stage heat signal, a call for first stage heat will energize two heating elements (HT1 and HT2). With either configuration, the control will energize three heating elements (HT1, HT2, and HT3) when it receives a first and second stage heat input from the thermostat.

**Limit Switch and Lockout Operation****Limit Switch Operation**

If the HEAT ENABLE jumper is in the HEAT position and the limit switch opens (fault code 1), the control will immediately de-energize all electric heat relay outputs and energize the blower (if it wasn't already energized). When the limit switch closes, the control will re-energize electric heat according to the thermostat inputs using normal timings.

**Fan On Lock Condition**

If the limit switch opens multiple times during a single call for electric heat (fault code 3) or if the limit switch opens for a long duration (fault code 4), the control will energize the blower until power is removed from the control. The control will cycle the heat outputs on and off as the limit re-closes and opens. The constant fan operation will signal the homeowner that a problem has occurred and a service call is required.

**Soft Lockout**

If the limit switch opens for a second long duration period during a single call for heat (fault code 5), the control will keep the blower locked on and lock out the heat outputs for one hour. The control will only reset this one hour lockout when the power is removed from the control. After the one hour period has passed, the control will re-energize electric heat according to the thermostat inputs using normal timings. The blower will remain locked on from the first long duration limit opening.

**Hard Lockout**

The control has a hard lockout condition during which the control will keep all heat outputs de-energized until power is removed from the control. The control de-energizes the blower five minutes after entering the hard lockout condition.

If the limit switch closes and re-opens during the one hour soft lockout period, the control will enter a hard lockout condition and continue to indicate a fault code 5.

If the limit switch opens twice when no call for electric heat is present (fault code 2), the control will enter a hard lockout condition.

If the limit switch opens multiple times soon after a soft lockout reset (fault code 6), the control will enter a hard lockout condition.

**Wiring Related Faults**

If the control receives a simultaneous call for heating and cooling (fault code 7), the control will perform both heating and cooling operations.

**SECTION VII: LINE POWER CONNECTIONS**

Power may be brought into the unit through the supply air end of the unit (top when unit is vertical) or the left side panel. Use the hole appropriate to the unit's orientation in each installation to bring conduit from the disconnect. The power lead conduit should be terminated at the electrical control box. Refer to Tables 9, 12, & 13 to determine proper wire sizing. Also see Figure 3. To minimize air leakage, seal the wiring entry point at the outside of the unit.

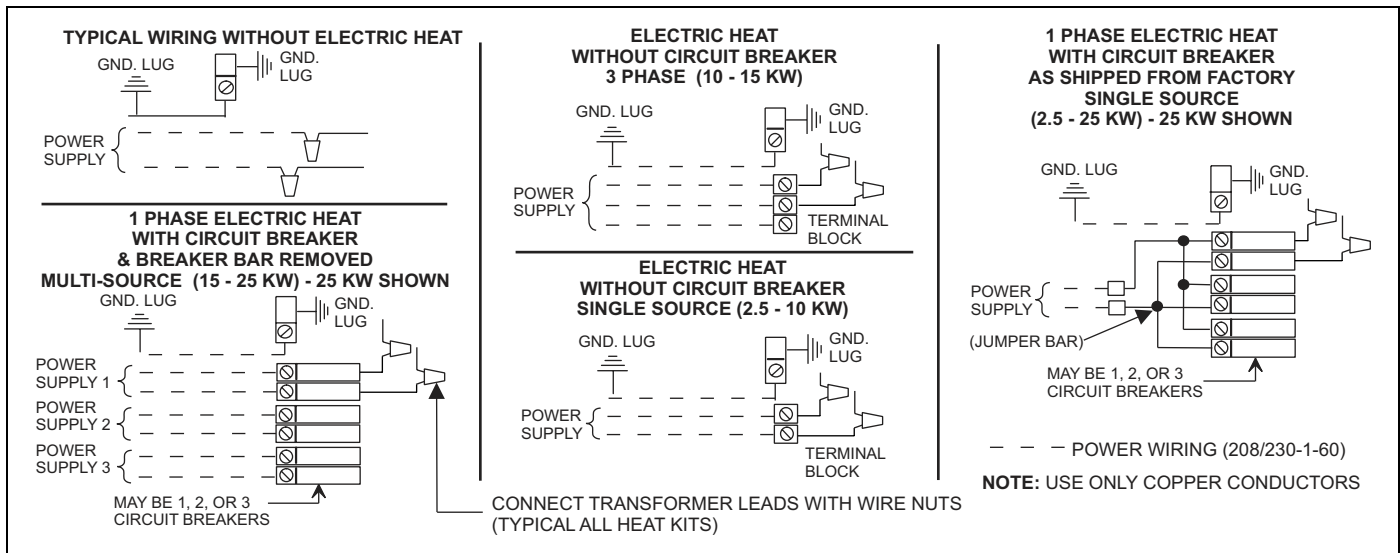

FIGURE 6: Line Power Connections

## SECTION VIII: AIRFLOW AND COMFORT SETTING SELECTION

### AIRFLOW SELECTION

The airflow and comfort setting selection jumpers must be set properly at the time of installation for proper system operation. Place jumpers in the proper locations based on the information shown in Tables 5-7 and Figure 5.

**NOTE:** Incorrect airflow and comfort settings may result in decreased system efficiency and performance.

TABLE 5: Cooling and Heat Pump Airflow Selection

HIGH SPEED COOLING AND HEAT PUMP AIRFLOW (CFM)					
MODEL				JUMPER SETTING	
12B	12D	16C	20D	COOL	ADJUST
1307	1366	1920	2209	A	B
1080	1097	1699	2022	B	B
1270	1312	1884	2178	A	A
943	957	1558	1798	B	A
1146	1167	1714	1965	A	C
1050	1051	1451	1843	C	B
870	863	1403	1596	B	C
771	739	1288	1700	D	B
931	927	1336	1608	C	A
693	658	1214	1493	D	A
851	830	1239	1430	C	C
655	594	1098	1334	D	C

**NOTE:**

- Both the COOL and the ADJUST tap must be set for the cooling airflow (CFM).
- Fan only airflow (CFM) = 63% of high speed cooling.
- Low speed cooling used only with two stage outdoor units. (Speed is preset to 65% of high speed).
- Dehumidification speed is 85% of cooling speed.
- When operating in both heat pump and electric heat modes, the airflow (CFM) will be whichever is greater.
- Airflow (CFM) indicator light (LED2) flashes once for every 100 CFM. (i.e.: 12 Flashes is 1200 CFM)

TABLE 6: Electric Heat Airflow

ELECTRIC HEAT AIRFLOW (CFM)				
MODEL				TAP SELECTIONS
12B	12D	16C	20D	HEAT
1270	1312	1884	2178	A
943	957	1558	1798	B
931	927	1336	1608	C
693	658	1214	1493	D

These variable speed air handlers are designed to deliver constant airflow (CFM) regardless of the external static pressure (ESP) in the ductwork. Therefore, if too many supply registers are closed, a filter becomes clogged, or there is a restriction in the ductwork, the motor will automatically operate at a higher speed to compensate for the higher ESP. This may result in a higher operating sound level.

All airflow (CFM's) are shown at 0.5" w.c. external static pressure. These units have variable speed motors that automatically adjust to provide constant CFM from 0.0" to 0.6" w.c. static pressure. From 0.6" to 1.0" static pressure, CFM is reduced by 2% per 0.1" increase in static. Operation on duct systems with greater than 1.0" w.c. external static pressure is not recommended.

To Set Cooling Airflow:

Refer to the outdoor unit technical guide for the recommended airflow with the matching evaporator coil. Refer to Table 5 for the possible high speed cooling and heat pump airflow selections.

Find the recommended system airflow in Table 5 for the installed air handler model.

Select the COOL airflow you need from Table 5. Set the COOL and ADJUST Jumpers on the control as indicated in Table 5.

To Set Heat Pump Airflow:

The heat pump airflow setting is the same as the cooling airflow setting. No additional airflow setting is required. However, you must set the MODE jumper to the HP position for proper system operation (See Figure 7).

To Set Electric Heat Airflow:

The blower speed required for electric heat is different than cooling. Refer to Tables 5 & 6 for the possible CFM selections. Refer to Table 11 for the minimum required airflow for the electric heater installed. Find the desired airflow in Table 6. Set the HEAT jumper on the control as indicated in Table 7.



*DO NOT change the ADJUST tap position on the control as this will change your cooling airflow previously selected.*

**Fan Only CFM:**

When the connection is made from "R" to "G", the fan only mode is activated. In this mode, the blower will deliver 63% of the cooling system CFM. This setting cannot be field adjusted.

**COMFORT SETTINGS****TABLE 7:** Comfort Setting Selection

DELAY TAP	COMFORT SETTING
A	Normal
B	Humid
C	Dry
D	Temperate

**Normal**

The normal setting provides a 30-second ramp-up from zero airflow to full capacity and a 30-second ramp-down from full capacity back to zero airflow. Whenever there is a change in airflow mode, such as a call for cooling or a change from low heat to high heat, the motor will take 30 seconds to ramp from one speed to the other.

**Humid**

The humid setting is best-suited for installations where the humidity is frequently very high during cooling season, such as in the southern part of the country. On a call for cooling, the blower will ramp up to 50% of full capacity and will stay there for two minutes, then will ramp up to 82% of full capacity and will stay there for five minutes, and then will ramp up to full capacity, where it will stay until the wall thermostat is satisfied. In every case, it will take the motor 30 seconds to ramp from one speed to another.

**Dry**

The dry setting is best suited to parts of the country where excessive humidity is not generally a problem, where the summer months are usually dry. On a call for cooling the motor will ramp up to full capacity and will stay there until the thermostat is satisfied. At the end of the cooling cycle, the blower will ramp down to 50% of full capacity where it will stay for 60 seconds. Then it will ramp down to zero. In every case, it will take the motor 30 seconds to ramp from one speed to another.

**Temperate**

The temperate setting is best suited for most of the country, where neither excessive humidity nor extremely dry conditions are the norm. On a call for cooling, the motor will ramp up to 63% of full capacity and will stay there for 90 seconds, then will ramp up to full capacity. At the end of the cooling cycle, the motor will ramp down to 63% of full capacity and will stay there for 30 seconds, then will ramp down to zero. In every case, it will take the motor 30 seconds to ramp from one speed to another.

**SECTION VII: UNIT DATA****TABLE 8:** Physical and Electrical Data - Cooling Only (60 Hz)

Models		MV12BN21	MV12DN21	MV16CN21	MV20DN21
Blower - Diameter x Width		10 x 7	10 x 10	10 x 10	10 x 10
Motor	HP	1/2	1/2	3/4	1
	Nominal RPM	1200	1200	1200	1200
Voltage		230			
Amps	Full Load (230)	4.3	4.3	5.0	7.0
	Type	DISPOSABLE OR PERMANENT			
Permanent Filter <sup>1</sup>	Size	16 x 20 x 1	24 x 20 x 1	20 x 20 x 1	24 x 20 x 1
	Filter Bulk Pack	1PF0601BK	1PF0604BK	1PF0602BK	1PF0604BK
Shipping / Operating Weight (lbs.)		75 / 71	88 / 82	88 / 82	94 / 88

1. Field Supplied.

**TABLE 9:** Electrical Data - Cooling Only (60 Hz)

Models	Total Motor Amps		Minimum Circuit Ampacity		Max. O.C.P. Amps/Type <sup>1</sup>	Minimum Wire Size A.W.G.
	60 Hertz		60 Hertz			
	208V	230V	208V	230V		
12B	4.7	4.3	5.9	5.4	15	14
12D	4.7	4.3	5.9	5.4	15	14
16C	6.1	5.0	7.6	6.9	15	14
20D	7.8	7.0	9.7	8.8	15	14

1. OCP = Over Current Protection device, must be HACR type Circuit Breaker or Time Delay fuse.

**TABLE 10:** Conversion Table

kW & MBH Conversions - for Total Power Input Requirement					
FOR	208V	OPERATION MULTIPLY	240V	TABULATED kW & MBH BY	.751
	230V		240V		.918
	220V		240V		.840

**TABLE 11:** Electrical Data - 1 Ø - 208/230-1-60

Models MV	Heater Models*	Max. Static	Min. Speed Tap	Total Heat <sup>1</sup>				kW Staging					
				kW		MBH		W1 Only		W2 Only		W1 & W2	
				208v	240v	208v	240v	208v	240v	208v	240v	208v	240v
12B	4HK*6500506	0.5	Heat-D	3.6	4.8	12.3	16.4	3.6	4.8	3.6	4.8	3.6	4.8
	4HK*6500806	0.5	Heat-D	5.6	7.5	19.2	25.6	2.8	3.8	5.6	7.5	5.6	7.5
	4HK*6501006	0.5	Heat-D	7.2	9.6	24.6	32.8	3.6	4.8	7.2	9.6	7.2	9.6
	4HK165N1506	0.5	Heat-D	10.8	14.4	36.9	49.1	3.6	4.8	7.2	9.6	10.8	14.4
12D	4HK*6500506	0.5	Heat-D	3.6	4.8	12.3	16.4	3.6	4.8	3.6	4.8	3.6	4.8
	4HK*6500806	0.5	Heat-D	5.6	7.5	19.2	25.6	2.8	3.8	5.6	7.5	5.6	7.5
	4HK*6501006	0.5	Heat-D	7.2	9.6	24.6	32.8	3.6	4.8	7.2	9.6	7.2	9.6
	4HK16501506	0.5	Heat-D	10.8	14.4	36.9	49.1	3.6	4.8	7.2	9.6	10.8	14.4
	4HK16501806	0.5	Heat-D	13.2	17.6	45.1	60.1	3.3	4.4	6.6	8.8	13.2	17.6
	4HK16502006	0.5	Heat-D	14.4	19.2	49.2	65.5	3.6	4.8	7.2	9.6	14.4	19.2
16C	4HK*6500506	0.5	Heat-D	3.6	4.8	12.3	16.4	3.6	4.8	3.6	4.8	3.6	4.8
	4HK*6500806	0.5	Heat-D	5.6	7.5	19.2	25.6	2.8	3.75	5.6	7.5	5.6	7.5
	4HK*6501006	0.5	Heat-D	7.2	9.6	24.6	32.8	3.6	4.8	7.2	9.6	7.2	9.6
	4HK16501506	0.5	Heat-D	10.8	14.4	36.9	49.1	3.6	4.8	7.2	9.6	10.8	14.4
	4HK16501806	0.5	Heat-D	13.2	17.6	45.1	60.1	3.3	4.4	6.6	8.8	13.2	17.6
	4HK16502006	0.5	Heat-D	14.4	19.2	49.2	65.5	3.6	4.8	7.2	9.6	14.4	19.2
20D	4HK*6501006	0.5	Heat-D	7.2	9.6	24.6	32.8	3.6	4.8	7.2	9.6	7.2	9.6
	4HK16501506	0.5	Heat-D	10.8	14.4	36.9	49.1	3.6	4.8	7.2	9.6	10.8	14.4
	4HK16501806	0.5	Heat-D	13.2	17.6	45.1	60.1	3.3	4.4	6.6	8.8	13.2	17.6
	4HK16502006	0.5	Heat-D	14.4	19.2	49.2	65.5	3.6	4.8	7.2	9.6	14.4	19.2
	4HK16502506	0.5	Heat-D	18.0	24.0	61.5	81.9	3.6	4.8	10.8	14.4	18.0	24

1. See conversion Table 10.

\* May be 0 (no breaker) or 1 (with breaker).

**TABLE 12:** Electrical Data - (For Single Source Power Supply) - Copper Wire 1 Ø - 208/230-1-60

Models MV	Heater Models*	Heater Amps 240V	Field Wiring					
			Min. Circuit Ampacity		Max. O.C.P. Amps/Type <sup>1</sup>		75°C Wire Size - AWG	
			208V	240V	208V	240V	208V	240V
12B	4HK*6500506	20.0	27.5	30.4	30	35	10	8
	4HK*6500806	31.3	39.7	44.5	40	45	8	8
	4HK*6501006	40.0	49.2	55.4	50	60	8	6
	4HK165N1506	60.0	70.9	80.4	90	90	4	3
12D	4HK*6500506	20.0	27.5	30.4	30	35	10	8
	4HK*6500806	31.3	39.7	44.5	40	45	8	8
	4HK*6501006	40.0	49.2	55.4	50	60	8	6
	4HK16501506	60.0	70.9	80.4	90	90	4	3
	4HK16501806	73.3	85.3	97.0	90	100	4	3
	4HK16502006	80.0	92.5	105.4	100	125	3	1
16C	4HK*6500506	20.0	29.3	31.9	30	35	10	8
	4HK*6500806	31.3	41.5	46.0	45	50	8	8
	4HK*6501006	40.0	51.0	56.9	60	60	6	6
	4HK16501506	60.0	72.6	81.9	90	90	3	3
	4HK16501806	73.3	87.01	98.5	90	100	3	2
	4HK16502006	80.0	94.3	106.9	100	125	3	1
20D	4HK*6501006	40.0	53.1	58.8	60	60	6	6
	4HK16501506	60.0	74.8	83.8	90	90	3	3
	4HK16501806	73.3	89.2	100.4	90	110	3	2
	4HK16502006	80.0	96.4	108.8	100	125	3	1
	4HK16502506	100.0	118.1	133.8	125	150	1	1/0

1. O.C.P. = Over Current Protection device, must be HACR type Circuit Breaker or Time Delay fuse.

\* May be 0 (no breaker) or 1 (with breaker).

**TABLE 13:** Electrical Data - (For **Multi-Source** Power Supply) - Copper Wire 1 Ø - 208/230-1-60

Models MV	Heater Models	Min. Circuit Ampacity			Max. O.C.P. Amps/Type <sup>1</sup>			75°C Wire Size - AWG		
		Circuit			Circuit			Circuit		
		1st	2nd	3rd	1st	2nd	3rd	1st	2nd	3rd
		208/240	208/240	208/240	208/240	208/240	208/240	208/240	208/240	208/240
12B	4HK165N1506	49.2 / 55.4	21.7 / 25.0	—	50 / 60	25 / 25	—	8 / 6	10 / 10	—
12D	4HK16501506	49.2 / 55.4	21.7 / 25.0	—	50 / 60	25 / 25	—	8 / 6	10 / 10	—
	4HK16501806	45.6 / 51.2	39.7 / 45.8	—	50 / 60	40 / 50	—	8 / 6	8 / 8	—
	4HK16502006	49.2 / 55.4	43.3 / 50.0	—	50 / 60	45 / 50	—	8 / 6	8 / 8	—
16C	4HK16501506	51.0 / 56.9	21.7 / 25.0	—	50 / 60	25 / 25	—	8 / 6	10 / 10	—
	4HK16501806	17.3 / 52.7	39.7 / 45.8	—	50 / 60	40 / 50	—	8 / 6	8 / 8	—
	4HK16502006	51.0 / 56.9	43.3 / 50.0	—	50 / 60	45 / 50	—	8 / 6	8 / 8	—
20D	4HK16501506	53.1 / 58.8	21.7 / 25.0	—	60 / 60	25 / 25	—	6 / 6	10 / 10	—
	4HK16501806	49.5 / 54.6	39.7 / 45.8	—	50 / 60	40 / 50	—	8 / 6	8 / 8	—
	4HK16502006	53.1 / 58.8	43.3 / 50.0	—	60 / 60	45 / 50	—	6 / 6	8 / 8	—
	4HK16502506	49.3 / 56.5	43.3 / 50.0	21.7 / 25.0	50 / 60	45 / 50	25 / 25	8 / 6	8 / 8	10 / 10

1. O.C.P. = Over Current Protection device, must be HACR type Circuit Breaker or Time Delay fuse.

**TABLE 14:** Electrical Data - 208/230-3-60

Models	Heat Kit - Three Phase	Max. Static	Min. Speed Tap	Total Heat <sup>1</sup>				KW Staging					
				KW		MBH		W1 Only		W2 Only		W1 + W2	
				208V	240V	208V	240V	208V	240V	208V	240V	208V	240V
12B	4HK06501025	0.5	Heat-D	7.2	9.6	24.6	32.8	7.2	9.6	7.2	9.6	7.2	9.6
12D	4HK06501025	0.5	Heat-D	7.2	9.6	24.6	32.8	7.2	9.6	7.2	9.6	7.2	9.6
	4HK06501525	0.5	Heat-D	10.8	14.4	36.9	49.1	10.8	14.4	10.8	14.4	10.8	14.4
16C	4HK06501825	0.5	Heat-D	12.9	17.2	44.7	58.7	12.9	17.2	12.9	17.2	12.9	17.2
	4HK06501025	0.5	Heat-D	7.2	9.6	24.6	32.8	7.2	9.6	7.2	9.6	7.2	9.6
	4HK06501525	0.5	Heat-D	10.8	14.4	36.9	49.1	10.8	14.4	10.8	14.4	10.8	14.4
20D	4HK06501825	0.5	Heat-D	12.9	17.2	44.7	58.7	12.9	17.2	12.9	17.2	12.9	17.2
	4HK06501025	0.5	Heat-D	7.2	9.6	24.6	32.8	7.2	9.6	7.2	9.6	7.2	9.6
	4HK06501525	0.5	Heat-D	10.8	14.4	36.9	49.1	10.8	14.4	10.8	14.4	10.8	14.4
	4HK16502525	0.5	Heat-D	18.0	24.0	61.4	81.4	9.0	12.0	18.0	24.0	18.0	24.0

1. See conversion Table 10.

**TABLE 15:** Electrical Data - (For **Single Source** Power Supply) - Copper Wire - 208/230-3-60

Models	Heat Kit - Three Phase	Heater Amps 240V	Field Wiring					
			Min. Circuit Ampacity		Max. O.C.P. <sup>1</sup> Amps/Type		75°C Wire Size - AWG	
			208V	240V	208V	240V	208V	240V
12B	4HK06501025	23.1	30.9	34.3	35	35	8	8
12D	4HK06501025	23.1	30.9	34.3	35	35	8	8
	4HK06501525	34.7	43.4	48.8	45	50	8	8
	4HK06501825	41.4	50.6	57.1	50	60	8	6
16C	4HK06501025	23.1	32.6	35.1	35	35	8	8
	4HK06501525	34.7	45.1	49.6	45	50	8	8
	4HK06501825	41.4	52.4	58.0	60	60	6	6
20D	4HK06501025	23.1	34.8	37.6	35	40	8	8
	4HK06501525	34.7	47.3	52.1	50	60	8	6

1. O.C.P. = Over Current Protection device, must be HACR type Circuit Breaker or Time Delay fuse.

2. Heaters are 3 Phase.

**TABLE 16:** Electrical Data - (For **Multi-Source** Power Supply) - Copper Wire - 208/230-3-60

Models	Heater Model	Minimum Circuit Ampacity			Max. O.C.P. <sup>1</sup> Amps/Type			75°C Wire Size - AWG		
		Circuit			Circuit			Circuit		
		1st	2nd	3rd	1st	2nd	3rd	1st	2nd	3rd
20D	4HK16502525	41.0 / 44.9	31.3 / 36.1	- / -	45 / 45	35 / 40	- / -	8 / 8	8 / 8	- / -

1. O.C.P. = Over Current Protection device, must be HACR type Circuit Breaker or Time Delay fuse.

TABLE 17: Cooling Air Flow Data

HIGH / LOW SPEED COOLING AND HEAT PUMP CFM									
12B Air Handler				12D Air Handler				JUMPER SETTINGS	
CFM		m <sup>3</sup> /min		CFM		m <sup>3</sup> /min		COOL Tap	ADJ Tap*
High	Low	High	Low	High	Low	High	Low		
1307	882	37.0	25.0	1366	869	38.7	24.6	A	B
1080	756	30.6	21.4	1097	717	31.1	20.3	B	B
1270	862	36.0	24.4	1312	856	37.2	24.2	A	A
943	689	26.7	19.5	957	646	27.1	18.3	B	A
1146	786	32.5	22.3	1167	761	33.0	21.5	A	C
1050	726	29.7	20.6	1051	703	29.8	19.9	C	B
870	632	24.6	17.9	863	580	24.4	16.4	B	C
771	594	21.8	16.8	739	520	20.9	14.7	D	B
931	668	26.4	18.9	927	629	26.2	17.8	C	A
693	565	19.6	16.0	658	495	18.6	14.0	D	A
851	624	24.1	17.7	830	567	23.5	16.1	C	C
655	567	18.5	16.1	594	488	16.8	13.8	D	C
16C Air Handler				20D Air Handler				JUMPER SETTINGS	
CFM		m <sup>3</sup> /min		CFM		m <sup>3</sup> /min		COOL Tap	ADJ Tap*
High	Low	High	Low	High	Low	High	Low		
1920	1321	54.4	37.4	2209	1394	62.6	39.5	A	B
1699	1189	48.1	33.7	2022	1394	57.3	39.5	B	B
1884	1296	53.3	36.7	2178	1381	61.7	39.1	A	A
1558	1094	44.1	31.0	1798	1378	50.9	39.0	B	A
1714	1193	48.5	33.8	1965	1226	55.6	34.7	A	C
1451	1037	41.1	29.4	1843	1143	52.2	32.4	C	B
1403	1009	39.7	28.6	1596	1226	45.2	34.7	B	C
1288	947	36.5	26.8	1700	1066	48.1	30.2	D	B
1336	978	37.8	27.7	1608	1023	45.5	29.0	C	A
1214	888	34.4	25.1	1493	967	42.3	27.4	D	A
1239	915	35.1	25.9	1430	911	40.5	25.8	C	C
1098	839	31.1	23.8	1334	877	37.8	24.8	D	C

All CFM's are shown at 0.5" w.c. external static pressure. These units have variable speed motors that automatically adjust to provide constant CFM from 0.0" to 0.6" w.c. static pressure. From 0.6" to 1.0" static pressure, CFM is reduced by 2% per 0.1" increase in static. Operation on duct systems with greater than 1.0" w.c. external static pressure is not recommended.

NOTE: At some settings, LOW COOL and/or LOW HEAT airflow may be lower than what is required to operate an airflow switch on certain models of electronic air cleaners. Consult the instructions for the electronic air cleaner for further details.

\* The ADJ "D" tap should not be used.

TABLE 18: Heating Air Flow Data

HIGH / LOW HEAT CFM									
12B Air Handler				12D Air Handler				JUMPER SETTINGS	
CFM		m <sup>3</sup> /min		CFM		m <sup>3</sup> /min		HEAT Tap	ADJ Tap*
High	Low	High	Low	High	Low	High	Low		
1270	791	36.0	22.4	1312	762	37.2	21.6	A	A
943	714	26.7	20.2	957	668	27.1	18.9	B	A
931	643	26.4	18.2	927	591	26.2	16.7	C	A
693	567	19.6	16.1	658	488	18.6	13.8	D	A
16C Air Handler				20D Air Handler				JUMPER SETTINGS	
CFM		m <sup>3</sup> /min		CFM		m <sup>3</sup> /min		HEAT Tap	ADJ Tap*
High	Low	High	Low	High	Low	High	Low		
1884	1217	53.3	34.5	2178	1217	61.7	34.5	A	A
1558	1065	44.1	30.2	1798	1036	50.9	29.3	B	A
1336	823	37.8	23.3	1608	748	45.5	21.2	C	A
1214	727	34.4	20.6	1493	551	42.3	15.6	D	A

All CFM's are shown at 0.5" w.c. external static pressure. These units have variable speed motors that automatically adjust to provide constant CFM from 0.0" to 0.6" w.c. static pressure. From 0.6" to 1.0" static pressure, CFM is reduced by 2% per 0.1" increase in static. Operation on duct systems with greater than 1.0" w.c. external static pressure is not recommended.

NOTE: At some settings, LOW COOL and/or LOW HEAT airflow may be lower than what is required to operate an airflow switch on certain models of electronic air cleaners. Consult the instructions for the electronic air cleaner for further details.

\* The ADJ "D" tap should not be used.

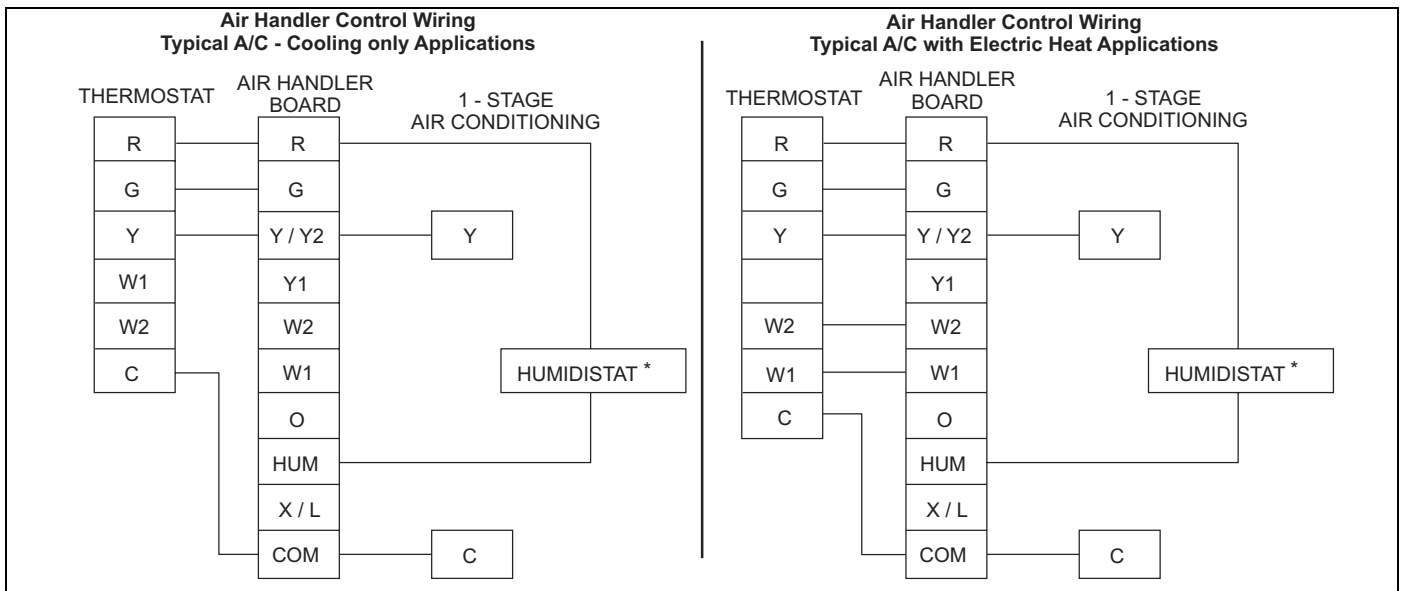
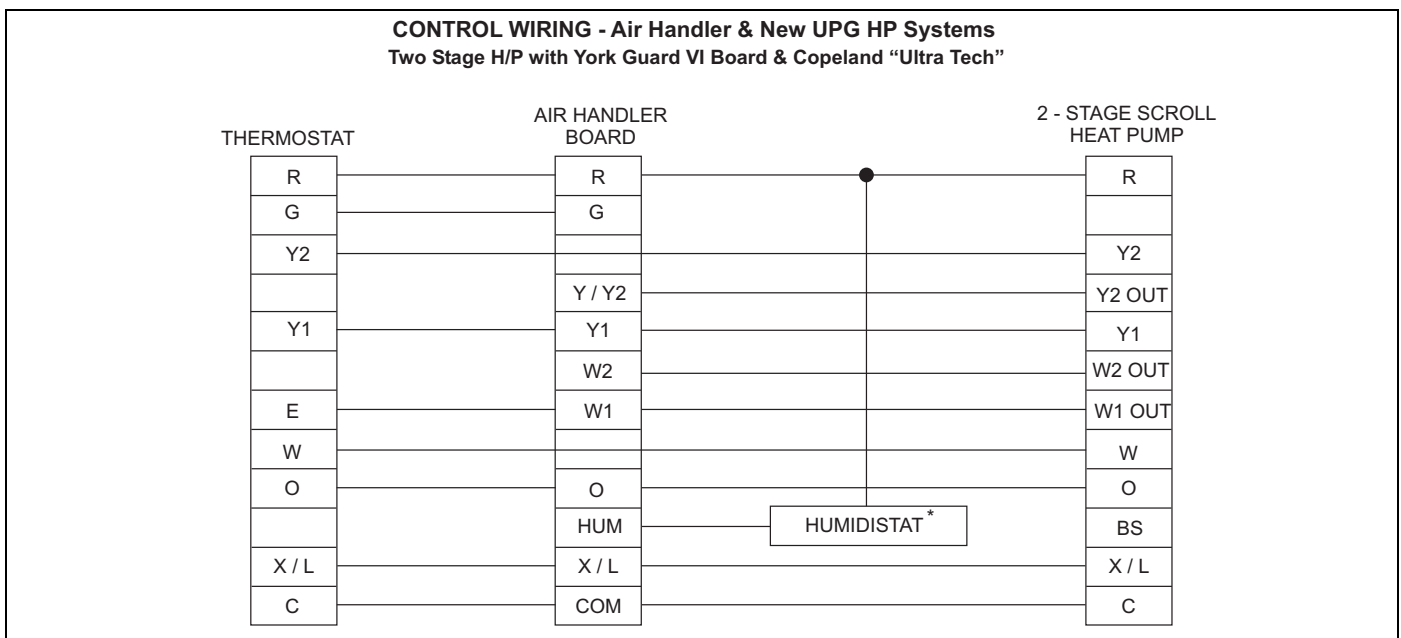

**FIGURE 7:** Cooling Models with and without Electric Heat Wiring

\* Optional dehumidification humidistat switch contacts open on humidity rise.

**NOTES:**

1. "Y/Y2" Terminal on air handler control board must be connected for full CFM and applications requiring 60 second blower off delay for SEER enhancement.
2. Remove humidistat jumper on air handler control board.
3. For heat pump applications - set MODE jumper on air handler control board to the HP position.
4. To change quantity of heat during HP defrost cycle - reverse connections at W1 and W2 on air handler control board.



**FIGURE 8:** Two-Stage Heat Pump Wiring

\* Optional dehumidification humidistat switch contacts open on humidity rise.

**NOTES:**

1. "Y/Y2" Terminal on air handler control board must be connected for full CFM and applications requiring 60 second blower off delay for SEER enhancement.
2. Remove humidistat jumper on air handler control board.
3. For heat pump applications - set MODE jumper on air handler control board to the HP position.
4. To change quantity of heat during HP defrost cycle - reverse connections at W1 and W2 on air handler control board.

**SECTION VIII: MAINTENANCE**

Filters must be cleaned or replaced when they become dirty. Inspect at least once per month. The frequency of cleaning depends upon the hours of operation and the local atmospheric conditions. Clean filters keep unit efficiency high.

**LUBRICATION**

The bearings of the blower motor are permanently lubricated.

## NOTES

## NOTES

---

# NOTES