

F1807 x FIP Brass PEX Adapter

Job Name	_____
Location	_____
Engineer	_____
Contractor	_____
Tag	_____ PO# _____

Specifications

Manufactured to the highest industry standards, Jones Stephens' F1807 lead-free brass crimp fittings provide precise, leak-free connections. The secure and reliable crimp fitting method provides full, immediate strength upon installation, with 360-degree uniform pressure. Approved for use with PEX piping.

Applications

Jones Stephens' F1807 x FIP Brass PEX Adapters are approved for use with commercial and residential non-potable water applications.

Materials

Lead-free brass

Dimensions and Product Offering

PART NO.	SIZE	A - IN (MM)	A TOLERANCE ±IN(MM)	B - IN (MM)	B TOLERANCE ±IN(MM)	WEIGHT - LBS (G)	WEIGHT TOLERANCE ±LBS (G)
C76041LF	0.50"	1.27 (32.30)	0.01 (0.20)	0.50"-14 NPT	0.002 (0.05)	0.07 (31.75)	0.02 (10.89)
C76042LF	0.50" F1807 x 0.75" FIP	1.32 (33.60)	0.01 (0.20)	0.75"-14 NPT	0.002 (0.05)	0.10 (45.36)	0.02 (10.89)
C76043LF	0.75"	1.32 (33.60)	0.01 (0.20)	0.75"-14 NPT	0.002 (0.05)	0.11 (49.90)	0.02 (10.89)
C76044LF	1.00"	1.65 (41.80)	0.01 (0.20)	1.00"-11.5 NPT	0.002 (0.05)	0.19 (86.18)	0.02 (10.89)
C76115LF	1.25"	1.89 (47.88)	0.02 (0.60)	1.25" - 11.5 NPT	0.028 (0.71)	0.42 (190.00)	0.02 (10.89)
C76129LF	1.50"	2.30 (58.30)	0.02 (0.60)	1.50" - 11.5 NPT	0.028 (0.71)	0.78 (356.00)	0.02 (10.89)
C76149LF	2.00"	2.72 (68.98)	0.02 (0.60)	2.00" - 11.5 NPT	0.028 (0.71)	0.78 (356.00)	0.02 (10.89)



Certifications/Listings/Approvals

- ASTM F1807
- NSF/ANSI/ CAN 372, NSF/ANSI/CAN 61, and NSF/ANSI 14
- CSA B137.5
- IAMPO Listed
- Lead Law Compliant
- Vermont Act 193 Compliant

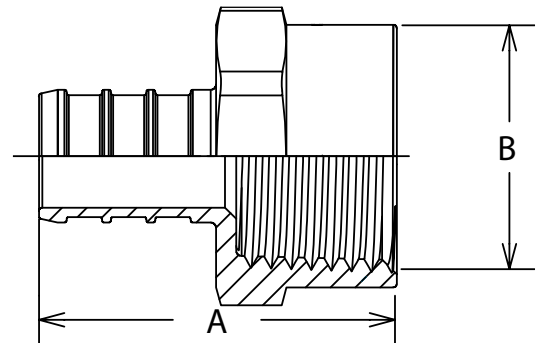

*Location of the nut may vary. This image is for dimensional purposes only.

	ID (Min.)	OD
F1807 Specified Dimensions	in. (mm)	in. (mm)
1/2" End Connection	.35	.471 ± .004
3/4" End Connection	.53	.667 ± .004
1" End Connection	.71	.856 ± .004
1-1/4" End Connection	.87	1.045 ± .004
1-1/2" End Connection	1.02	1.233 ± .006
2" End Connection	1.37	1.602 ± .005