



SERVICE PARTS LIST

BULLETIN NO.
54-06-2140

SPECIFY CATALOG NO. AND SERIAL NO. WHEN ORDERING PARTS		REVISED BULLETIN	DATE
M18™ ROCKET™ DUAL POWER TOWER LIGHT			Sep. 2017
CATALOG NO.	2131-20	STARTING SERIAL NO.	J50A
		WIRING INSTRUCTION	

EXAMPLE:
Component Parts (Small #)
Are Included When Ordering
The Assembly (Large #).

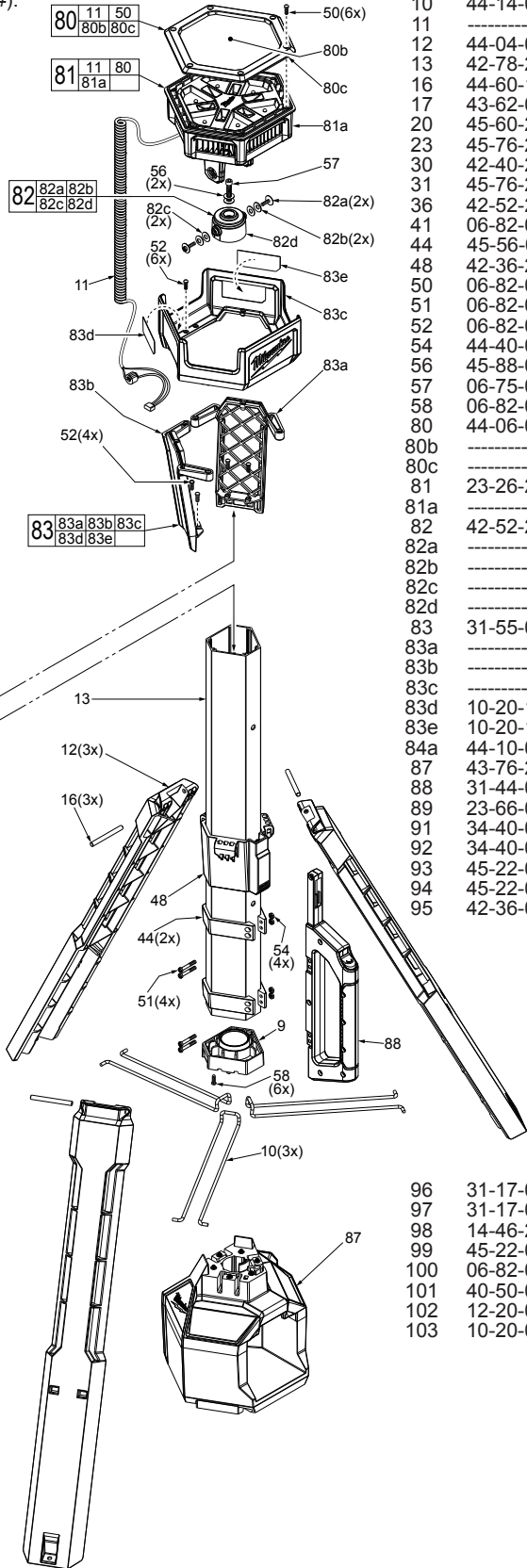
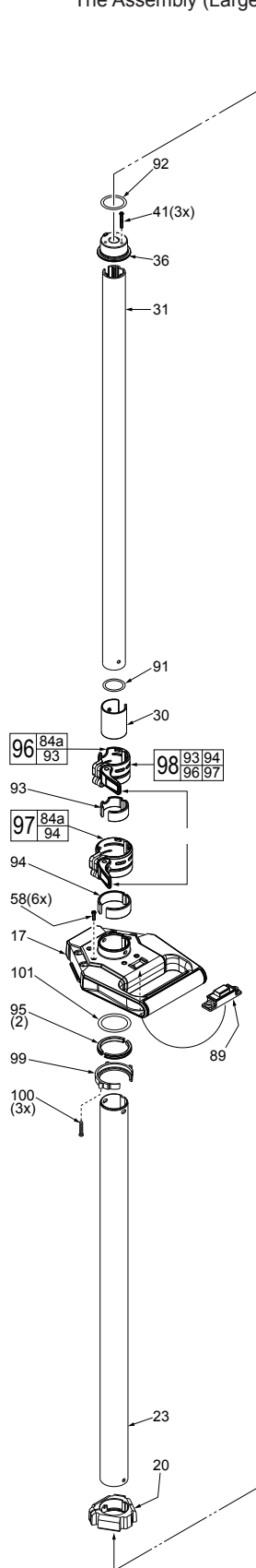

FIG.	PART NO.	DESCRIPTION OF PART	NO. REQ.
9	31-12-0027	Main Support Tube Lower Cap	(1)
10	44-14-0240	Wire Leg Linkage	(3)
11	-----	Power Cord with Ferrite Bead	(1)
12	44-04-0105	Support Leg	(3)
13	42-78-2131	Main Support Column	(1)
16	44-60-1655	Leg Support Pin	(3)
17	43-62-0396	Switch Handle Support (less switch)	(1)
20	45-60-2131	Large Tube Base Support	(1)
23	45-76-2120	Large Tube	(1)
30	42-40-2131	Small Tube Slide Bushing	(1)
31	45-76-2131	Small Tube	(1)
36	42-52-2120	LED Mounting Cap Support with Nut	(1)
41	06-82-0069	M3.0 x 30 Pan Hd. ST T-10 Screw	(3)
44	45-56-0110	Sliding Handle Guide Strap	(2)
48	42-36-2131	M18™ Leg Support Bracket	(1)
50	06-82-0019	3.5 x 14 Pan Hd. ST T-15 Screw	(16)
51	06-82-0059	M4.0 x 27.5 Pan Hd. T-20 Machine Screw	(4)
52	06-82-0039	M3.5 x 12 Pan Hd. ST T-15 Screw	(10)
54	44-40-0485	M4 Nut	(4)
56	45-88-0202	Washer	(3)
57	06-75-0006	M6 Hex Socket Machine Screw	(1)
58	06-82-0029	3.5 x 20 Pan Hd. ST T-15 Screw	(12)
80	44-06-0102	Lens Cover Assembly	(1)
80b	-----	LED Lens Cover	(1)
80c	-----	LED Lens	(1)
81	23-26-2131	LED Light Assembly w/ Power Cord and Grommet	(1)
81a	-----	LED Light Assembly	(1)
82	42-52-2131	LED Mounting Cap w/ Washers and Screws	(1)
82a	-----	PH2 Round Head Washer Screw	(2)
82b	-----	Spring Washer	(2)
82c	-----	Washer	(2)
82d	-----	Mounting Cap	(1)
83	31-55-0075	LED Shroud Assembly	(1)
83a	-----	Shroud Support - Right	(1)
83b	-----	Shroud Support - Left	(1)
83c	-----	LED Shroud	(1)
83d	10-20-1018	Warning Label - Left	(1)
83e	10-20-1019	Warning Label - Right	(1)
84a	44-10-0685	Clamp Lever	(2)
87	43-76-2131	Electronics and Housing Assembly	(1)
88	31-44-0347	Sliding Handle Assembly	(1)
89	23-66-0063	Switch Box Assembly	(1)
91	34-40-0355	O-Ring	(1)
92	34-40-0357	O-Ring	(1)
93	45-22-0180	Upper Sleeve	(1)
94	45-22-0185	Lower Sleeve	(1)
95	42-36-0195	Retaining Bracket (2 piece)	(1)
96	31-17-0090	Small Tube Clamp Assembly	(1)
97	31-17-0095	Large Tube Clamp Assembly	(1)
98	14-46-2131	Upper And Lower Clamp Service Kit	(1)
99	45-22-0165	Sleeve	(1)
100	06-82-0180	M2.5 x 20mm Round Hd. Torx Screw	(3)
101	40-50-0255	Torsion Spring	(1)
102	12-20-0126	Service Nameplate (Not Shown)	(1)
103	10-20-0363	Warning Label (Not Shown)	(1)

Adjustments may be needed to Clamping Assemblies 96 and 97 to prohibit sliding when latched. Tighten or loosen adjustment screw and flip clamp lever to the feel. If clamping the lever seems too difficult **do not force lever**. Screw should be loosened slightly and try securing the lever again. If lever seems too loose, tighten screw slightly and flip clamp lever to the feel.

