

## SPECIFICATIONS

Model	A95 (ducted)	A95F (movable, with casters)
Capacity <sup>(1)</sup> (water removal)	95 ppd	
Energy factor <sup>(1)</sup> (efficiency)	2.1 L/kWh (4.4 pints/kWh)	
Voltage, Phase, Frequency	120VAC, 1 Phase, 60 Hz	
Current draw <sup>(1)</sup>	8.0 Amps	
Power (Watts) <sup>(1)</sup>	905 Watts	
Noise	54 dBA ducted	60 dBA
Dimensions: (cabinet only) <sup>(2)</sup>	Width: 12½"	12½"
	Height: 14½"	14½" cabinet 17½" with casters
	Length: 27½"	27½"
Weight	70 lbs.	

### Inlet air operating conditions during:

<b>Dehumidification:</b>	50°F–104°F, 40°F dew point min.
<b>Ventilation:</b>	40°F–140°F, 0%–99% RH (non-condensing)

<sup>(1)</sup>Rated capacity and energy factor test done and current draw measured in accordance with AHAM DH-1 2008 at 80°F/60% RH inlet air at 0.0 ESP. <sup>(2)</sup>Height does not include adjustable feet. The width excludes the filter doors and length excludes the duct collars.

## FEATURES

Model	A95 (ducted)	A95F (movable, with casters)
Control <sup>(3)</sup>	Built-in digital control with display	
Control mounting option	Field interchangeable from top to front	Top only
Cabinet insulation	½" EPS	
Air discharge orientation	Top or end	End
Inlet/Outlet duct collars	10" dia.	N/A
Backdraft damper at outlet	Included	N/A
Filter	MERV 11 disposable	
Refrigerant	R410A	
Coil type	Corrosion resistant aluminum	
8' Power cord	Plug type	
Discharge air temperature rise	10°F–30°F	
Drain connection	¾" MNPT Threaded	
Warranty	5 Years on all parts including refrigeration system	

<sup>(3)</sup>Built-in automatic control capable to be set up for dehumidification and ventilation or zoning.

## INCLUDED ITEMS

Drain fitting	¾" MPT x ¾" barbed
10 ft. Drain tubing	¾" ID
Duct collars	10" Round (A95 only)
Manual	Installation instruction

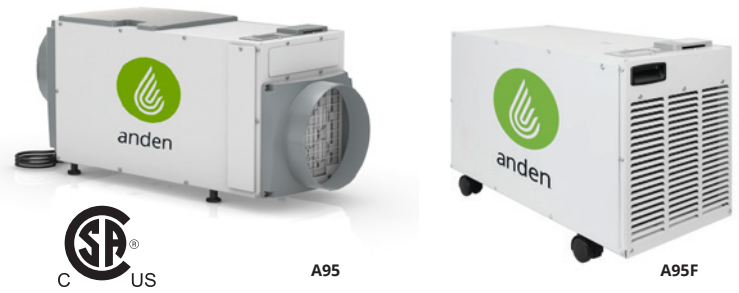

A95

A95F

## PRINCIPLE OF OPERATION

The Anden Model A95 Series Dehumidifier is designed to dehumidify the air coming into the unit by passing the incoming air over an evaporator coil to drop the air temperature below the dew point of the air. Moisture is removed from the air and drained out of the unit to a common floor or waste drain. The air is then reheated in the condenser coil and exits the unit.

Dehumidification occurs until the set point is reached, then shuts off until periodic sampling determines a need for operation.

## APPLICATION



The Anden Model A95 Series is the perfect solution for the precise management of humidity required in an indoor growing environment.

## CIRCULATION

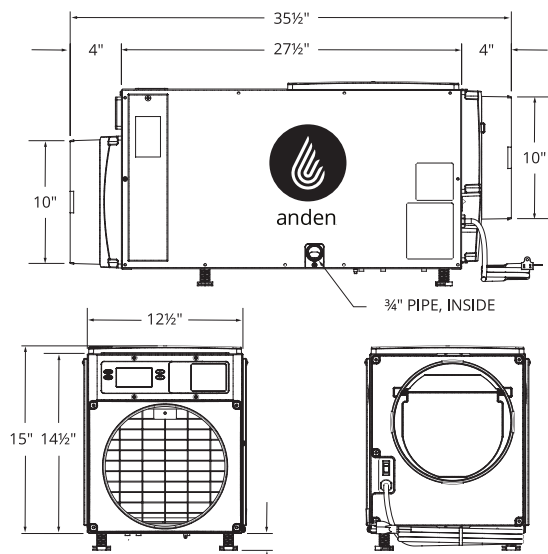
The Model A95 Series can also be programmed to circulate air within a grow facility. Proper air flow carries moisture away from the plants, helping to prevent fungus, disease and plant pests from damaging the crop. Circulating the air also maximizes the application of CO<sub>2</sub> in the grow facility.

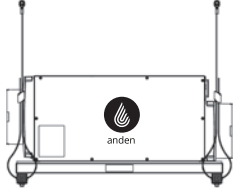

# Installation Options for the Anden A95 Dehumidifier Series

APPLICATIONS	
<p><b>Movable</b></p> <ul style="list-style-type: none"> <li>Air is pulled into the dehumidifier directly from the space, dehumidified and returned to the space.</li> </ul>	
<p><b>Inlet and outlet ducted (Model A95 only)</b></p> <ul style="list-style-type: none"> <li>Ducted with 10" flex duct or hard pipe.</li> <li>Circulates air to equalize humidity, temperature and move CO<sub>2</sub>.</li> </ul>	
<p><b>Suspended</b></p> <ul style="list-style-type: none"> <li>Air is pulled into the dehumidifier directly from the space, dehumidified and returned to the space.</li> <li>The dehumidifier is mounted from the ceiling using our hanging kit (Model 5660) to save space in the facility.</li> </ul>	

## Optional Controls and Sensors

### Wi-Fi Thermostats



Wi-Fi thermostats and mobile app provide humidity and temperature alerts directly to your smart phone or tablet. Control and monitor climate conditions in your grow room 24/7/365 from anywhere.



**Model A77**  
Dedicated monitoring and control of each dehumidifier at canopy height.



**Wi-Fi Model 8840**  
Easy-to-use color touch screen with all control options on the home screen.



**Wi-Fi Model 8830**  
Easy-to-use touch screen with all control options on the home screen.



**Wi-Fi Model 8820**  
Easy-to-use touch screen designed for temperature and humidity control.

### Sensor



**Model 8082 Sensor**  
Monitor temperature and humidity in multiple locations. Readings averaged to balance temperature and humidity.



**Model 8083 Sensor**  
Flush temperature and RH module. Averages four temperature and four RH values.

### MODEL A77 SPECIFICATIONS

Electrical	
<b>Input voltage and current</b>	Voltage: 35VDC (supplied by dehumidifier control board)
<b>Output</b>	Communication (RS485)
Control	
<b>Control range</b>	35%–80% RH
<b>Accuracy</b>	+/-5% RH
<b>Differential</b>	3% RH
<b>Low limit</b>	40°F dew point
<b>High limit</b>	99°F dry bulb