

# Built-In Microwave/Convection Oven

CWB713P2NS1

CAFÉ

DISTINCT BY DESIGN™



## FEATURES & BENEFITS

More room for more food - Entertaining unexpected guests is easy with the 1.7 cu. ft. capacity that helps prepare a large amount of food quickly

A microwave that's as versatile as you are - Achieve crisp, golden brown results with a convection cooking setting and a special rack that allows air to circulate around foods for even heat distribution

Delicious results in no time at all - Enjoy oven-quality results in mere minutes with a fast cook setting that combines convection and microwave cooking technology

A simple and smart addition to your culinary repertoire - Fresh vegetables and rice are perfectly prepared with a steam cook button that simplifies the entire process

Quick control and effortless cleaning - Easily choose a setting on your convection microwave using sleek glass touch controls that are simple to navigate and wipe clean

Cook your way with just one touch of a button - Enjoy the convenience of one-touch cooking with My Cycle, a custom cycle that remembers the exact time and temperature settings of your favorite foods

Prepare and preserve the freshest meals - Let bread rise naturally and keep entrées hot and ready with a warming and proofing oven that ensures fresh results, regardless of when you sit down to eat

## APPEARANCE

Color Appearance	Stainless Steel
Handle	Yes

## FEATURES

Control Type	Glass Touch
Cooking Technology	Convection
Microwave Watts (IEC-705)	975 W
Power Levels	10
Convection Cooking Controls	Combination Fast Cook; Convection Bake/Broil; Warm/Proof
Microwave Sensor Cooking Controls	Auto Cook; Popcorn; Steam Cook
Microwave Convenience Cooking Controls	Time Cook; Defrost: Weight/Time
Control Features	Start/Pause; Cancel/Off; Control Lock; Power; Timer On/Off; Clock; Add 30 Seconds; Back; Settings; Cooking Complete Reminder; Demo Mode
Microwave Oven Interior	Stainless Steel
Electronic Digital Display with Clock	Yes
Interior Oven Light	Halogen
Rack Type	Removable Oven Rack - Pedestal
Turntable	Glass
Turntable Size	16.0 in

## CAPACITY

Total Capacity (cubic feet)	1.7 cu ft
-----------------------------	-----------

## POWER / RATINGS

Electrical Input - 120V Amperage	14.0
Electrical Input - 120V Watts	1600
Frequency (MHz)	2450
Input Volts/Hertz	120/60
Voltage (MIN)	120.0 V

## WEIGHTS & DIMENSIONS

Approximate Shipping Weight	92 lb
Cabinet Width	30 in
Cavity (W x H x D)	20-1/16 x 8-1/2 x 17
Net Weight	75 lb
Overall Depth	24-3/4 in
Overall Height	19-1/8 in
Overall Width	29-7/8 in

## WARRANTY

Parts Warranty	Limited 1-year entire appliance
Labor Warranty	Limited 1-year entire appliance
Warranty Notes	See written warranty for full details

# Built-In Microwave/Convection Oven

CWB713P2NS1

# CAFÉ

DISTINCT BY DESIGN™

## DIMENSIONS AND INSTALLATION INFORMATION (IN INCHES)

**Note:** Cabinets installed adjacent to wall ovens must have an adhesion spec of at least a 194°F temperature rating.

**INSTALLATION INFORMATION:** Before installing, consult installation instructions packed with product for current dimensional data.

Note: Cabinets installed adjacent to wall ovens must have an adhesion spec of at least 194° F temperature rating.

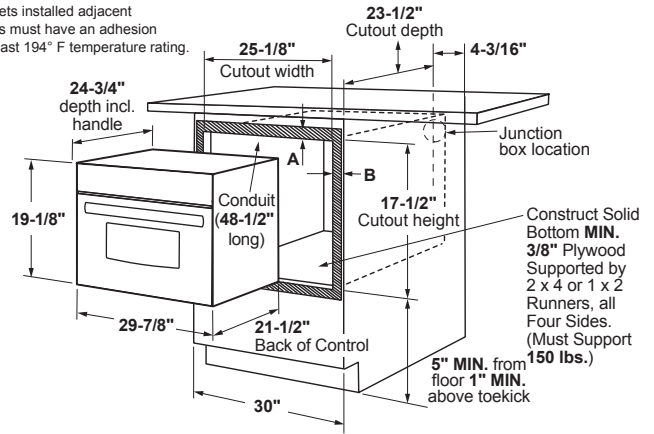

(Must support 130 lbs.)

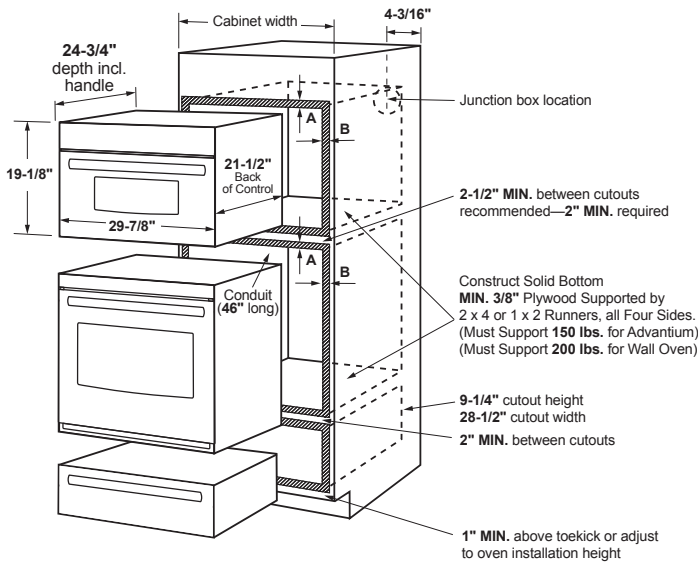

A= Allow 1" overlap of oven over bottom edge of cutout, and allow 1-1/4" overlap at top edge of cutout.  
 B= Allow 11/16" - 3/4" for overlap of oven over side edges of cutout.

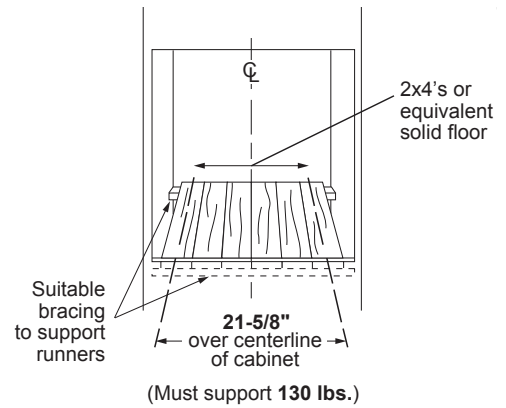

## ADDITIONAL ACCESSORIES



CXWS0H0PMSS  
Brushed Bronze  
1 handle



CXWS0H0PMBT  
Brushed Stainless  
1 handle



CXWS0H0PMCUC  
Brushed Black  
1 handle



CXWS0H0PMBZ  
Brushed Copper  
1 handle