

Café™ 27" Five in One Oven with 120V Advantium® Technology

CSB912P2NS1

CAFÉ

DISTINCT BY DESIGN™



FEATURES & BENEFITS

Unmatched versatility to unleash your imagination - Enjoy a whole new level of cooking flexibility with a single oven that can be used in five different ways. Use it as a Convection Oven, Microwave, Toaster Oven, Warming/Proofing Oven, and Precision Cook Oven with Advantium Technology.

Cook smarter, not longer - Achieve oven-quality results in a fraction of the time as halogen light, microwave energy and True European Convection work together to provide the exact amount and type of heat your food needs, precisely when it needs it

Brighten up life in the kitchen - Easily navigate wall oven settings using a stunning full color display that adds an unexpected touch of style to your kitchen

Say goodbye to rubbery leftovers - Achieve crispy results at microwave speed with more than 20 reheat programs that make leftovers taste like new

The perfect marriage of quality and speed - Eliminate the need for preheating and cook your favorite foods two- to four-times faster than a conventional oven

Healthy meals without the fuss - Fresh vegetables and rice are perfectly prepared with a steam cook option that simplifies the entire process

Create a look that matches your personal style - Select any combination of premium finishes and hardware options to create a stunning look customized to any owner's taste

Clean-up has never been easier - Keep your oven looking like new at all times with steam clean

The perfect fit you've always dreamed of - When you're updating your kitchen, attention to detail is a priority. That's why Café Advantium wall ovens are guaranteed for an exact fit for an easy and seamless replacement.

APPEARANCE

Color Appearance	Stainless Steel
Handle	Brushed Stainless; Café Pro Style

FEATURES

Cooking Modes	Precision Cook; Crisp Reheat; Convection; Microwave; Proof, Warm
Style	Built-In
Control Type	7" Full Color LCD Touch Control
Interior Oven Light	Yes
Oven Interior	Stainless Steel
Microwave Watts (IEC-705)	950
Turntable Size	16
Control Features	Add 30 Sec; Over 175 Programmed Menu Selections
Cooking Technology	5 in 1 Oven with 120V Advantium
Oven Rack Features	Pedestal Rack

CAPACITY

Total Capacity (cubic feet)	1.7
-----------------------------	-----

POWER / RATINGS

Electrical Input - 120V Amperage	15
Electrical Input - 120V Watts	1800
Volts/Hertz	120V; 60Hz
Broiler Wattage	1200W

WEIGHTS & DIMENSIONS

Approximate Shipping Weight	92
Cavity (W x H x D)	20-1/16 x 8-1/2 x 17
Height (Front)	20-1/8
Net Weight	82
Overall Height	20-1/8
Overall Width	26-3/4
Overall Depth	21-1/2
Cabinet Width	27

ACCESSORIES

Metal Oven Pan	Yes - Precision Cooking Tray
----------------	------------------------------

Café™ 27" Five in One Oven with 120V Advantium® Technology

CSB912P2NS1

CAFÉ

DISTINCT BY DESIGN™

WARRANTY

Parts warranty	Limited 1-year entire appliance Limited 5-year magnetron tube
Labor warranty	Limited 1-year entire appliance
Warranty notes	See written warranty for full details

DIMENSIONS AND INSTALLATION INFORMATION

Note: Cabinets installed adjacent to wall ovens must have an adhesion spec of at least a 194°F temperature rating.

Note: 2" minimum between cutouts when installed above warming drawer or single wall oven.

Installation information: Before installing, consult installation instructions packed with product for current dimensional data.

Note: Use of the accessory drawer will replace the bottom trim piece for applicable installations. Please see installation instructions for full details.

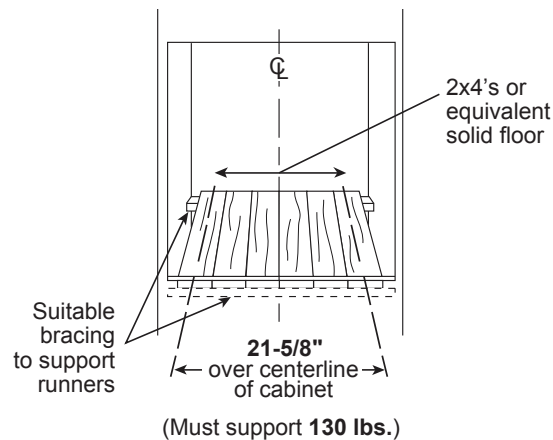
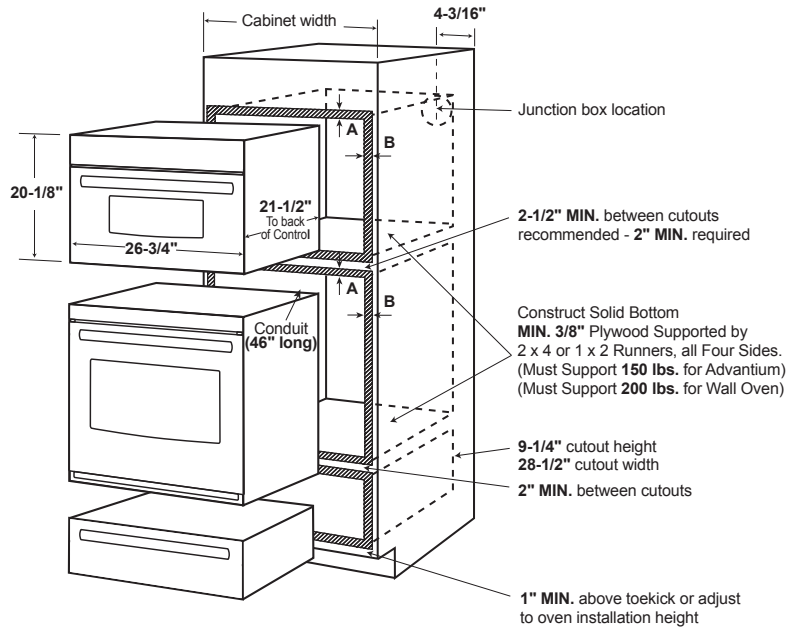

Note: Cabinets installed adjacent to wall ovens must have an adhesion spec of at least 194° F temperature rating.

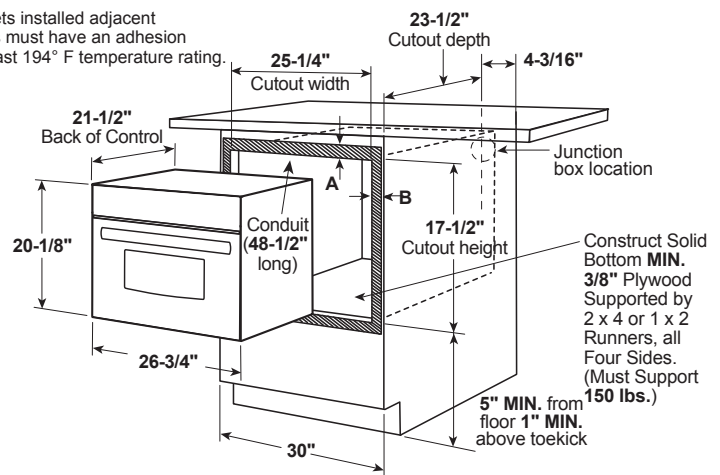

A= Allow 1" overlap of oven over bottom edge of cutout, and allow 2-3/4" overlap at top edge of cutout.
B= Allow 3/4" - 2-1/8" for overlap of oven over side edges of cutout.

Café™ 27" Five in One Oven with 120V Advantium® Technology

CSB912P2NS1

CAFÉ

DISTINCT BY DESIGN™

DIMENSIONS AND INSTALLATION INFORMATION

Preparation with an Accessory Drawer

Prepare the opening: The Advantium 240V can be installed in combination with other appliances. Always follow each product's Installation Instructions to complete the installation.

Single oven installation: Order a 30" or 27" wide single oven cabinet or cut the opening in a wall to the dimensions shown.

* For existing cutouts, a maximum width of 28-1/2" is acceptable. If the opening is slightly wider, secure a furring strip on each side of the cutout for securing the oven.

- Allow 3/4" to 2-1/8" case trim overlap on the sides and 1" overlap on the bottom of the opening for all models. The amount of overlap on the sides depends on the actual cutout width. Allow 2-1/4" case trim overlap on the top.
- Oven overlaps will conceal cut edges on all sides of the opening.

When installed over a single oven or a warming drawer, allow at least 2" between the two openings. This separation will provide clearance for bottom overlap of the Advantium 240V and the other appliance overlaps. Construct a solid oven floor of 3/8" min. thick plywood supported by 2 x 4 or 2 x 2 runners on all sides.

- the support must be level and rigidly mounted, flush with the bottom edge of the cutout.

* For existing cutouts, a maximum width of 28-1/2" is acceptable. If the opening is slightly wider, secure a furring strip on each side of the cutout for securing the oven.

Note: Additional clearances between the cutouts may be required. Check to be sure the oven supports above the Warming Drawer location do not obstruct the required interior depth and height. See Warming Drawer installation instructions for details.

Installation Over a Wall Oven and Warming Drawer:

* For existing cutouts, a maximum width of 28-1/2" is acceptable. If the opening is slightly wider, secure a furring strip on each side of the cutout for securing the oven.

Note: Additional clearances between the cutouts may be required. Check to be sure the oven supports above the Warming Drawer location do not obstruct the required interior depth and height. See Warming Drawer installation instructions for details.

Caution: For personal safety, the mounting surface must be capable of supporting the cabinet load, in addition to the added weight of this approximate 80-pound oven and 30-pound drawer, plus additional oven loads of up to 50 pounds or a total weight of 160 pounds.

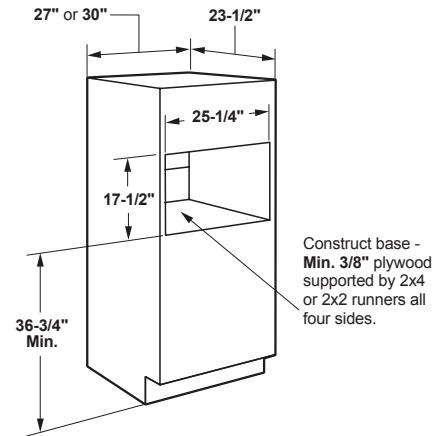

Installation over Warming Drawer:

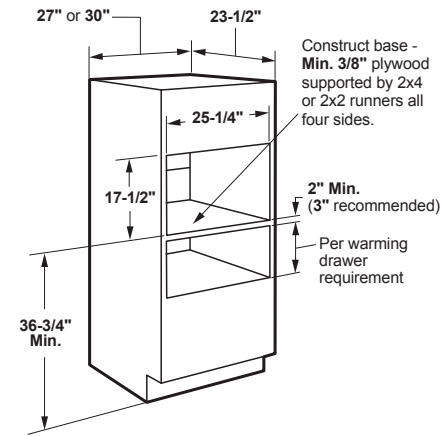

Installation over a Wall Oven and Warming Drawer:

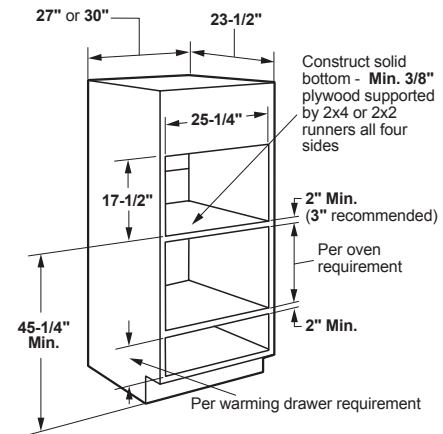

ADDITIONAL ACCESSORIES



CXWS7H0PNBZ
Brushed Bronze
1 handle



CXWS7H0PNSS
Brushed Stainless
1 handle



CXWS7H0PNBT
Brushed Black
1 handle



CXWS7H0PNCU
Brushed Copper
1 handle