

Infiniti Tankless™ K-Series

INDOOR MODEL

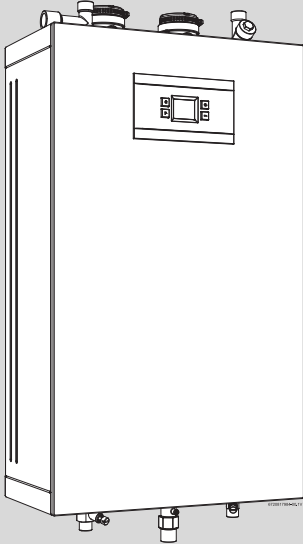

⚠ WARNING! Improper installation, adjustment, alteration, service or maintenance can cause injury or property damage. Refer to this manual. For assistance or additional information consult a qualified installer, service agency or the gas supplier.

NOTICE

Upon completion of the installation, these instructions should be handed to the user of the appliance for future reference.

⚠ WARNING: If the information in these instructions is not followed exactly, a fire or explosion may result causing property damage, personal injury or death.

- Do not store or use gasoline or other flammable vapors and liquids in the vicinity of this or any other appliance.
- **WHAT TO DO IF YOU SMELL GAS**
 - Do not try to light any appliance.
 - Do not touch any electrical switch; do not use any phone in your building.
 - **Immediately call your gas supplier from a neighbor's phone. Follow the gas supplier's instructions.**
 - If you cannot reach your gas supplier, call the fire department.
- Installation and service must be performed by a qualified installer, service agency or the gas supplier.

6720817-984 (2019/06) US

RTG-K-199/160N1 - 199,000/160,000 BTU/Hr - Natural Gas
RTG-K-199/160X1 - 199,000/160,000 BTU/Hr - Liquefied Petroleum (LP) Gas

Temperature Modulated with Electronic Ignition Suitable for heating potable water and space heating
(Intended for variable flow applications)

Featuring:

STEADISE™ Technology
and
SRT™ Scale Reduction Technology



As required by the state of California Proposition 65.

BRADFORD WHITE
WATER HEATERS

Table of contents

1 Key to symbols and safety instructions 3

1.1 Key to symbols 3

1.2 Safety instructions 3

2 Safety information 8

3 Appliance details 9

3.1 Features 9

3.2 Specifications (Technical data) 10

3.3 Unpacking the heater 12

3.4 General rules to follow for safe operation 13

3.5 Dimensions 15

4 Installation instructions 16

4.1 Installation tools 16

4.2 Introduction 16

4.3 Proper location for installing your heater 16

4.4 Heater placement and clearances 17

4.5 Hanging appliance on the wall 17

4.6 Venting 18

4.7 Factory settings 33

4.8 Gas piping & connections 33

4.9 Water quality 37

4.10 Water connections 37

4.11 Domestic hot water recirculation with external pump 39

4.12 Adjusting the recirculation settings 39

4.13 Recirculation with the RTG-K-160/199N/X1 39

4.14 Space heating applications 40

4.15 Measuring gas pressure 43

5 Electrical connections 43

5.1 Electrical power supply 43

5.2 Position of the fuses in control unit 44

6 Operation instructions 44

6.1 For your safety read before operating your water heater 45

6.2 Power 45

6.3 Error code reset 45

6.4 Temperature selection 46

6.5 Information /Adjustments menu 47

6.5.1 P4 (Information) 47

6.5.2 P9 (Purge) 48

6.5.4 SA (Settings) 49

6.5.5 LM (Temperature Limit) 50

6.5.6 PE (Appliance Type) 50

6.5.7 PF (Bypass Activation) 50

7 Maintenance and service 52

7.1 Required annual maintenance 53

7.2 Winterizing for seasonal use 54

7.3 Mineral scale build-up 54

8 Troubleshooting 55

8.1 Introduction 55

8.2 Burner does not ignite when hot water is turned ON 55

8.3 Water is too hot 56

8.4 Water is not hot enough 56

8.5 Low water flow/pressure 56

8.6 Hot water temperature fluctuates at faucet 56

8.7 Noisy burner/heater during operation 56

8.8 Error codes C1, C2, CF and/or CE 57

8.9 Error codes EA and/or EC 57

8.10 Manifold gas pressure 57

8.11 Adjusting Gas/Air flow 58

8.11.3 Factory default settings 61

8.12 CO emission check 61

9 Problem solving 63

9.1 Error code diagnostics 63

10 Electrical diagram 68

11 Sensor resistance charts 70

12 Software main menu structure 71

13 Interior components diagram and parts list 72

14 Protecting the environment 74

15 Installer Checklist to be completed by installer upon installation 74

16 LIMITED TANKLESS HEATER WARRANTY 75

1 Key to symbols and safety instructions

1.1 Key to symbols

Warnings

In warnings, signal words at the beginning of a warning are used to indicate the type and seriousness of the ensuing risk if measures for minimising danger are not taken.

The following signal words are defined and can be used in this document:



DANGER:

DANGER indicates a hazardous situation which, if not avoided, will result in death or serious injury.



WARNING:

WARNING indicates a hazardous situation which, if not avoided, could result in death or serious injury.



CAUTION:

CAUTION indicates a hazardous situation which, if not avoided, could result in minor or moderate injury.

NOTICE:

NOTICE is used to address practices not related to personal injury.

Important information



The info symbol indicates important information where there is no risk to people or property.

Additional symbols

Symbol	Meaning
▶	a step in an action sequence
→	a reference to a related part in the document
•	a list entry
–	a list entry (second level)

Table 1

1.2 Safety instructions

⚠ WARNING:

Before installation,

- ▶ Read all instructions. Perform the steps in the indicated sequence.
- ▶ Have the water heater inspected by a trained service technician at least once every year.
- ▶ Failure to comply with these instructions can result in severe, possibly fatal, personal injury as well as damage to property and equipment.

⚠ DANGER:

Installation and servicing.

Risk of fire when soldering and brazing!

- ▶ Take appropriate protective measures when soldering and brazing around combustible and flammable material.
- ▶ Ensure that only a licensed contractor installs or services the water heater.
- ▶ On hot components use only material with adequate temperature stability.

⚠ CAUTION:

Installation and commissioning.

- ▶ In the Commonwealth of Massachusetts, the water heater must be installed by a licensed plumber.

⚠ CAUTION:

- ▶ To ensure that the water heater functions properly, follow these installation and maintenance instructions.
- ▶ Never close the blow-off line of the pressure safety valve. For safety reasons, water may escape during heating.

⚠ DANGER:

Risk of explosion!

If you smell gas,

- ▶ Turn off the gas shut-off valve.
- ▶ Open windows and doors.
- ▶ Do not try to light the appliance.
- ▶ Do not touch any electrical switch, telephone, and do not use outlets.
- ▶ Extinguish all open flames. Do not smoke! Do not use lighters!
- ▶ Warn all occupants of the building. Do not ring doorbells!
- ▶ If you can hear gas leaking, leave the building immediately.
- ▶ Prevent others from entering the building and notify the police and fire department from outside the building.
- ▶ From outside the building, call the gas utility company and a trained and certified installer.

⚠ DANGER:

If you smell flue gas

- ▶ Switch off the appliance.

- ▶ Open windows and doors.
- ▶ Inform the certified installer who installed the appliance.

⚠ DANGER:

Insufficient ventilation may cause toxic flue gas to escape. Risk of poisoning.

- ▶ Never close off or reduce the size of the air intake and outlet openings.
- ▶ The appliance must not be operated until any obstructions have been removed.
- ▶ Inform the customer of the problem and the associated dangers.

⚠ DANGER:

Danger from escaping flue gases.

- ▶ Ensure all vent pipes and chimneys are not damaged or blocked.
- ▶ Connect only one appliance to each vent system or chimney liner.
- ▶ The venting system piping must not feed into another air extraction duct.
- ▶ Do not route the flue system piping through or inside another air extraction duct.

⚠ DANGER:

Danger of explosion of flammable gases.

- ▶ Work on gas components may only be carried out by a trained and certified installer.

- ▶ Installation, gas and flue connection, initial commissioning, electrical connections and annual maintenance must only be carried out by a trained and certified installer.

⚠ CAUTION:

Combustion air.

- ▶ Keep the combustion air free of corrosive substances (halogenated hydrocarbons that contain chlorine or fluorine compounds).

⚠ WARNING:

Never shut off safety valves!

- ▶ Water may escape from the safety valve at any time when the water is being heated.

⚠ WARNING:

Inspection/maintenance

- ▶ Servicing and repairs may only be carried out by a trained and certified installer.
- ▶ Immediately correct all faults to prevent system damage.
- ▶ Use only Bradford White spare parts! Damage caused by the use of parts not supplied by Bradford White may void the warranty.

⚠ CAUTION:

Instruct the customer

- ▶ Explain to the customer how the appliance works and how to operate it.

- ▶ Inform the customer that he/she must not carry out any alterations or repairs.

⚠ DANGER:

Danger from electric shock

- ▶ Ensure that only an authorized contractor performs electrical work.
- ▶ Before performing electrical work, disconnect the power and secure the unit against unintentional reconnection.
- ▶ Ensure the system has been disconnected from the power supply.

⚠ DANGER:

Risk of scalding at the hot water fixture

- ▶ When the water heater is in operation, temperatures in excess of 120 °F (49 °C) can occur. To limit the temperature at the tap, install a thermostatic DHW mixing valve.
- ▶ Water heated for washing the laundry, dishes and for other cleaning purposes can cause scalding and permanent injuries.
- ▶ Children, disabled and elderly people are at highest risk of being scalded. Never leave such individuals in the tub or shower unattended under any circumstances. Children must not be allowed to operate hot water faucets themselves.

- ▶ If the building has occupants in the above groups who operate hot water faucets, or state laws / local ordinances stipulate specific water temperatures, take the following precautions:
 - Use the lowest possible temperature setting.
 - To prevent scalding, install a tempering device, such as an automatic mixing valve, at hot water tap or water heater. Select and install the automatic mixing valve in accordance with the valve manufacturer's recommendations and instructions.
- ▶ Water exiting from drain valves can be extremely hot. To avoid injuries:
 - Check that all connections are tight.
 - Direct exiting water away from people.
- ▶ Measures must be taken to protect against excessive temperature and pressure! Installation of a T&P safety valve is required.

⚠ WARNING:
Electrical safety.

To protect against corrosion and ensure compliance with the rules for electrical safety, observe the following points:

- ▶ Use metal fittings for potable water heating systems with plastic piping.
- ▶ Use only original accessories from the manufacturer.

- ▶ When installation of the water heater is complete, inspect and confirm proper ground conductor.

⚠ CAUTION:

Maintenance

Customers are advised to:

- ▶ Inspect and maintain the water heater on a yearly basis. Service as needed. See chapter 7.1.
- ▶ Only use genuine spare parts.

⚠ WARNING:

Flooding

- ▶ After a flood, do not use the appliance if any part has been submerged. Damage to appliances that have been submerged can be quite severe and pose numerous safety risks.
- ▶ Every appliance that has been submerged must be replaced.

⚠ DANGER:

Risk of explosion!

For your safety

- ▶ Do not store or use gasoline or other flammable, combustible or corrosive vapors and liquids in the vicinity of this or any other appliance.

**DANGER:****Fatal accidents!**

Carbon monoxide poisoning.

- ▶ Carefully plan where you install the heater. Correct combustion air supply and flue pipe installation are very important. If a gas appliance is not installed correctly, fatal accidents can result such as carbon monoxide poisoning or fire.

**DANGER:**

Carbon monoxide poisoning.

- ▶ Exhaust gas must be vented to outside using approved vent material. See table 5, page 19 (In Canada use only ULCS636 approved material). Vent and combustion air connector piping must be sealed gas-tight to prevent flue gas spillage, carbon monoxide emissions and risk of fire, resulting in severe personal injury or death. Approved vent terminations must be used.

**DANGER:****Electric shock!**

- ▶ Field wiring connections and electrical grounding must comply with local codes, or in the absence of local codes, with the latest edition of the National Electric Code, ANSI/NFPA 70, or in Canada, all electrical wiring must comply with the local codes and the Canadian Electrical Code, CSA C22.1 Part 1.

**DANGER:****Electric shock!**

Shock hazard: line voltage is present.

- ▶ Before servicing the water heater, unplug power supply cord from outlet. Failure to do so could result in severe personal injury or death.

**WARNING:****Damage to the appliance from over pressure.**

- ▶ The heater must be disconnected from the gas supply piping system during any pressure testing of that system at test pressures equal to or more than 0.5 psi (1.4 W.C.).

NOTICE:

- ▶ The appliance should be located in an area where leakage of the heater or connections will not result in damage to the area adjacent to the appliance or to lower floors of the structure. When such locations cannot be avoided, it is recommended that a suitable drain pan, adequately drained, be installed under the appliance. The pan must not restrict combustion air flow.

**WARNING:**

- ▶ The maximum inlet gas pressure must not exceed the value specified by the manufacturer and the minimum value listed is for the purpose of input adjustment.

NOTICE:

- ▶ If a water heater is installed in a closed water supply system, such as one having a backflow preventer in the cold water supply line, means shall be provided to control thermal expansion. Contact the water supplier or local plumbing inspector on how to control this situation.

**WARNING:****Fire danger!**

- ▶ Keep appliance area clear and free from combustible materials, gasoline and other flammable vapors and liquids.

NOTICE:**Risk of CO poisoning!**

- ▶ Do not obstruct the flow of combustion and ventilation air.

**WARNING:****Risk of scalding and property damage.**

- ▶ Precautions must be taken prior to manually operating the relief valve to avoid contact with hot water discharged from the relief valve and to prevent water damage.

NOTICE:

Appliance damage!

- ▶ Label all wires prior to disconnection when servicing controls. Wiring errors can result in improper and dangerous operation. Verify proper operation after servicing.

WARNING:

Relief valve discharges!

- ▶ If a relief valve discharges periodically, this may be due to thermal expansion in a closed water supply system. Contact the water supplier or local plumbing inspector on how to correct this situation. Do not plug the relief valve.

WARNING:

Personal injury from toxic chemicals.

- ▶ Toxic chemicals, such as those used for boiler treatment, shall not be introduced into the potable water used for space heating.

WARNING:

Personal injury from toxic chemicals.

- ▶ A water heater which will be used to supply potable water shall not be connected to any heating system or component(s) previously used with a nonpotable water heating appliance.

2 Safety information

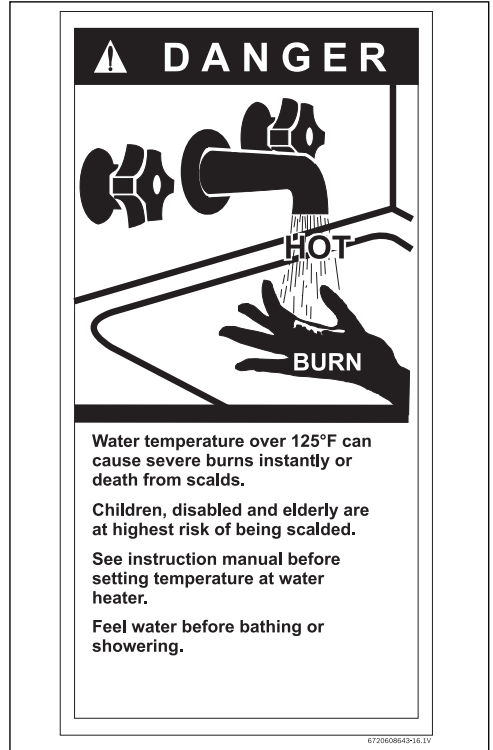

Fig. 1

The chart below shows the relationship between water temperature and time until there is a risk of scalding. It can be used as the basis for determining the safest water temperature for your application.

Temperature	Time to severe scalding ¹⁾
120 °F (48 °C)	longer than 5 minutes
125 °F (51 °C)	1.5 to 2 minutes
130 °F (54 °C)	approx. 30 seconds
135 °F (57 °C)	approx. 10 seconds
140 °F (60 °C)	less than 5 seconds
145 °F (62 °C)	less than 3 seconds
150 °F (65 °C)	approx. 1.5 seconds
155 °F (68 °C)	approx. 1 second

- 1) Source: Moritz, A.R. and Henriques, F.C., Jr. (1947). Studies of thermal injury. II. The relative importance of time and surface temperature in the causation of cutaneous burns, Am J of Pathol, 23, 695-720.

Table 2 Approximate time-temperature relationship until there is a risk of scalding



WARNING:

CANCER AND REPRODUCTIVE HARM

WWW.P65WARNINGS.CA.GOV

AS REQUIRED BY THE STATE OF CALIFORNIA PROPOSITION 65.

This Bradford White water heater complies with the State of California Lead Law (AB1953).

3 Appliance details

3.1 Features

Parts

- Key Pad interface control.
- High power segmented burner with low NOx emissions. Modulating gas valve with pressure regulator.
- Modulating water valve.
- Active bypass water valve for quick response to changing water flows.
- Burner power segmentation with modulation range from 1:22.

High quality materials for long working life

- Copper primary heat exchanger.
- Stainless Steel 316L condensing heat exchanger.

Features

- Compact space saver: mounts on a wall with a supplied bracket.
- Easily removable one-piece cover.
- On/Off and Temperature touch control buttons.
- Reset function - Long press (> 3 sec.) the ON/OFF button.
- Programmable default temperature.
- Failure codes with message display for easy diagnostics and repair.
- Real-time diagnostics for troubleshooting/informational purposes.
- Built in freeze prevention.
- Integrated siphon to limit condensate freezing in external condensate pipes.

- Available common vent kits, more information at www.bradfordwhite.com.

Note: The freeze prevention kit is designed to provide protection for the water heater down to **approximately -4 °F for short term conditions only when protected from direct wind exposure**. It will not protect the appliance in areas where the temperature is routinely expected to be below freezing. Drain the water heater in the event of power outage in freezing conditions.

- The freeze prevention kit will not protect plumbing outside the appliance from freezing. Precautions should be taken.

Accessories

- Neutralizer Kit
- Tank loading Aquastat (7736505665)
- Tank loading NTC (7736505666)
- Cascading kit (7736502750)



Bradford White is constantly improving its products, therefore specifications are subject to change without prior notice.

3.2 Specifications (Technical data)

Approved in US/Canada

Technical characteristics	Units	Infiniti Tankless™ K-Series RTG-K-199N/X1	Infiniti Tankless™ K-Series RTG-K-160N/X1
Capacity			
Maximum flow rate at a 35 °F (19.4 °C) rise ¹⁾	GPM (l/min)	11.2 (42.4)	9 (34)
Maximum flow rate at a 45 °F (25 °C) rise	GPM (l/min)	8.7 (32.9)	7(26.7)
Maximum flow rate at a 55 °F (30.6 °C) rise	GPM (l/min)	7.2 (27.5)	5.8 (21.9)
Maximum flow rate at a 75 °F (41.7 °C) rise	GPM (l/min)	5.2 (19.7)	4.2 (15.9)
Maximum flow rate at a 90 °F (50 °C) rise	GPM (l/min)	4.4 (16.6)	3.5 (13.2)
Maximum output	BTU/hr (kW)	197 010 (57.7)	157 608 (46.2)
Maximum input ²⁾	BTU/hr (kW)	199 000 (58.3)	160 000 (46.64)
Thermal efficiency (Efficiency in %)	%	> 99%	> 99%
Minimum Input ³⁾	BTU/hr (kW)	9 000 (2.6)	9 000 (2.6)
Temperature Control⁴⁾			
Selection range	°F (°C)	100 - 120 ⁵⁾ (38 - 49)	100 - 120 ⁵⁾ (38 - 49)
Default temperature	°F (°C)	120 (49)	120 (49)
Temperature stability ⁶⁾	°F (°C)	± 2 (± 1)	± 2 (± 1)
Gas Requirement			
Gas connection	inches	¾"	¾"
Peak load inlet gas pressure ⁷⁾			
Propane	water column	8" - 13"	8" - 13"
Natural Gas	water column	3.5" - 10.5"	3.5" - 10.5"
To assure maximum heat input at maximum vent length minimum gas pressure should be 5" W.C. (199kBtu) and 4" W.C. (160kBtu). For more information see section 4.6.3.			
Water			
Top hot water connection NPT	inches	¾"	¾"
Top cold water connection NPT	inches	¾"	¾"
Minimum water flow ⁸⁾	GPM (l/min)	0.45 (1.7)	0.45 (1.7)
Maximum water pressure	PSI (bar)	150 (10.3)	150 (10.3)
Minimum recommended water pressure	PSI (bar)	18 (1.2)	18 (1.2)
Minimum well pressure	PSI (bar)	30 (2.1)	30 (2.1)
Water valve material		Polymer (PPS) (Polypropylene Sulfide)	Polymer (PPS) (Polypropylene Sulfide)
Combustion			
CO level	ppm	≤ 250 (measured)	≤ 250 (measured)
CO ₂ level (set from factory)	%	see table 28	see table 28
Dimensions			
Depth	inches (mm)	9 ²⁷ / ₃₂ (250)	9 ²⁷ / ₃₂ (250)
Width	inches (mm)	18 ¹⁹ / ₃₂ (471.5)	18 ¹⁹ / ₃₂ (471.5)

Technical characteristics	Units	Infiniti Tankless™ K-Series RTG-K-199N/X1	Infiniti Tankless™ K-Series RTG-K-160N/X1
Height	inches (mm)	31½ (800)	31½ (800)
Net weight	pounds (kg)	77.5 (35.2)	73.2 (33.2)
Gross weight	pounds (kg)	89.95 (40.8)	85.54 (38.8)
Electrical			
Voltage	V AC	120	120
Frequency	Hz	60	60
Amperage (Idle)	mA	40	40
Amperage (operation)	A	≤ 2.7	≤ 2.7
Water protection ⁹⁾	IP	X4D	X4D

- 1) These flows rates are based upon setting the unit to higher temperatures and then mixing down using cold water after the unit.
- 2) Input rating is based on sea level operation and need not be changed for operation up to 2000 ft (610 m) elevation. For operation at elevations above 2000 ft (610 m), input rating is automatically reduced at the rate of 4 percent for each 1000 ft (305 m) above sea level.
- 3) When converted to LPG the minimum input is 17 000 BTU/hr (5 kW).
- 4) With constant flow.
- 5) Can be reprogrammed to achieve up to 140 °F (60 °C) (see chapter 6.4).
- 6) Requirements: Steady flows, single unit installations, up to 140 °F (60 °C).
- 7) To measure Gas Pressure, see Measuring Gas Pressure, section 4.15, page 43.
- 8) Refers to activation point. Deactivation point is 0.35GPM (1.3 l/min).
- 9) Protection against water spray.

Table 3

Safety devices

- Flame failure device (flame detection via ionization rod)
- Overheat prevention
- Inlet water temperature sensor
- Outlet water temperature sensor
- Exhaust flue gas temperature sensor
- Water flow sensor
- Air flow sensing technology (Combustion Management System)
- Scaling detection sensor (HE flue gas temperature sensor)

3.3 Unpacking the heater

The heater is default-set by the manufacturer to operate with Natural Gas; for use with Liquid Propane, follow the conversion instructions in section 6.7.1. **Before commissioning the unit be certain you have the heater correctly set for your type of Gas: Propane or Natural Gas.** Identification labels are found on the shipping box, and on the rating plate which is located on the left side (when facing appliance front) of the cover.

MODEL # / N° DE MODELE		FD # / N° DE SERIE	
ORDER # / N° DE COMMANDE		FD # / N° DE SERIE	
AUTOMATIC INSTANTANEOUS WATER HEATER / CHAUFFE EAU INSTANTANÉ RÉGULATEUR AUTOMATIC WATER HEATER / CHAUFFE EAU CER 6.3 200			
FOR OPERATION AT OUTLET WATER TEMPERATURE OF 140°F HYDROSTATIC PRESSURE 300 psi MAX. HYDROSTATIC WORKING PRESSURE 150 psi.			
POUR LE FONCTIONNEMENT À UNE TEMPÉRATURE DE 140°F A.S.L. RÉGULATEUR SCHEMÉ À UNE PRESSION HYDROSTATIQUE MAX. 300 psi. PRESSION HYDROSTATIQUE DE FONCTIONNEMENT 150 psi.			
0 - 2000 Ft. 0 - 610 m STANDARD ALT. ALTITUDE NORMALE	RATINGS AT ALTITUDE / ÉVALUATION À DIFFÉRENTE ALTITUDE		0 - 6500 Ft. 0 - 1970 m HIGH ALTITUDE HAUTE ALTITUDE
MAX. INPUT BTU/H	CONSUMPTION MAX. BTU/H		
MIN. INPUT BTU/H	CONSUMPTION MIN. BTU/H		
REC. RATINGS, U.S. GAL./MIN.	RECOMMANDÉ U.S. GAL./MIN.		
ORIFICE SIZE	TAILLE DES ORIFICES		
INLET PRESS., IN W.C.	PRESSION D'ENTRÉE EN Po		
VENT. DIA., INCHES	D'ÂMETRE DU CONDUIT DE CHEMINÉE		
MIN. GAS SUPPLY PRESS., IN W.C.	LA PRESSION MINIMUM DU GAZ EN Po		
FOR PURPOSE OF RATE ADJUSTMENT POUR RAISON D'AJUSTEMENT			
ADJUSTABLE FOR WATER HEAVINESS RÉGULATEUR POUR L'EAU DUR			
TYPE OF GAS		MAX. GAS	
TYPE DE GAZ		LA PRESSION MAX. EST DE 3,7 MPa (1/2 PSIG)	
TYPE DE GAZ		LA PRESSION MAX. EST DE 3,7 MPa (1/2 PSIG)	
FOR USA, HIGH ALTITUDE FOR CANADA			

Fig. 2 Rating plate

- [1] Serial number
- [2] Type of gas (Natural gas by default)

3.3.1 The box includes

- Water Heater
- LP Conversion Kit
- Pressure relief valve
- Bracket and screws for wall hanging the heater
- Installation manual (manual can be downloaded at www.bradfordwhite.com)

The RTG-K-199/160N/X1 is not approved or designed for:

- **Manufactured (mobile) homes, boats or any mobile installation. (Modular homes are acceptable for installation).**
- **Use above 8000 ft A.S.L. altitude.**
- **Applications where inlet water temperature is higher than 140 °F (60 °C) for Residential appliances. (In these applications a 3 way valve or thermostatic mixing valve must be installed).**
- **Use with dishwasher pre rinse spray valves.**
- **Booster applications.**



In preheated inlet water applications (i.e. solar preheat), activation flow rate will vary depending upon the unit set point, inlet water temperature and the demand flow rate thru the unit. Please consult Bradford White for further details to determine if this will function in your application.

3.3.2 Remove front cover

- ▶ Loosen two Phillips head screws located on the bottom of the unit (fig. 3).

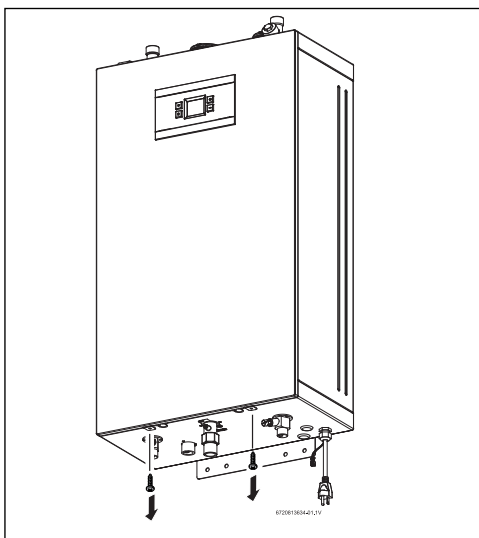

Fig. 3 Loosen two Phillips head screws

- ▶ Slowly open the front cover [1].

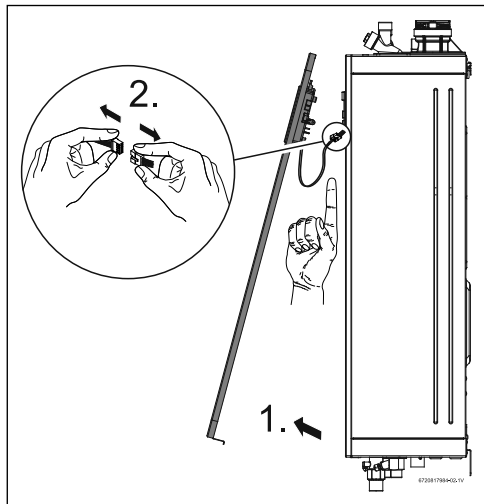

Fig. 4 Open front cover

- ▶ Disconnect the wire from the HMI (display) [2].
- ▶ Lift the front cover to remove from the appliance.
- ▶ Install the appliance so that it hangs vertically.

3.4 General rules to follow for safe operation

⚠ Warning: Safety Rules!

1. You must follow these instructions when you install your heater. In the United States: The installation must conform with local codes or, in the absence of local codes, the National Fuel Gas Code ANSI Z223.1/NFPA 54.

In Canada: The Installation must conform with CSA B149.(1,2) INSTALLATION CODES and /or local installation codes.

2. Carefully plan where you install the heater. Correct combustion air supply and vent pipe installation are very important. If not installed correctly, fatal accidents can occur, such as carbon monoxide poisoning or fire.
3. When the unit is installed indoors with DIRECT VENT (exhaust vent and air intake connected to the outside) it is permitted to be located in bathrooms, bedrooms and occupied rooms that are normally kept closed. See section 4.6 (page 18). If the unit will be installed indoors and use indoor combustion air (NON-DIRECT VENT), the place where you install the heater must have enough ventilation. **The National Fuel Gas Codes do not allow NON-DIRECT VENT gas fired water heater installations in bathrooms, bedrooms or any occupied rooms normally kept closed.** See chapter 4.6 (page 18).
4. You must correctly vent your heater. See section 4.6 (page 18) on VENTING.
5. The appliance and its gas connection must be leak tested before placing the appliance in operation. The appliance must be isolated from the gas supply piping system by closing its individual manual gas shutoff valve (not supplied with heater) during any pressure testing at pressures in excess of ½ Psig (3.5 kPa / 14" W.C.).

6. Keep the water heater area clear and free from combustibles and flammable liquids. Do not locate the heater over any material which might burn.
7. Correct gas pressure is critical for the proper operation of this heater. Gas piping must be sized to provide the required pressure at the maximum output of the heater, while all the other gas appliances are in operation. Check with your local gas supplier, and see the section on connecting the gas supply. See section 4.8 (page 33).
8. Should overheating occur or the gas supply fail to shut off, turn off the gas supply at the manual gas shut off valve, on the gas line. Note: manual gas shutoff valve is not supplied with the heater but must be field installed.
9. Do not use this appliance if any part has been underwater. Immediately call the responsible party for the installation of your appliance to inspect the appliance and to replace any part of the water heater which has been underwater.
10. Failure to install the heater correctly may lead to unsafe operation.

3.5 Dimensions

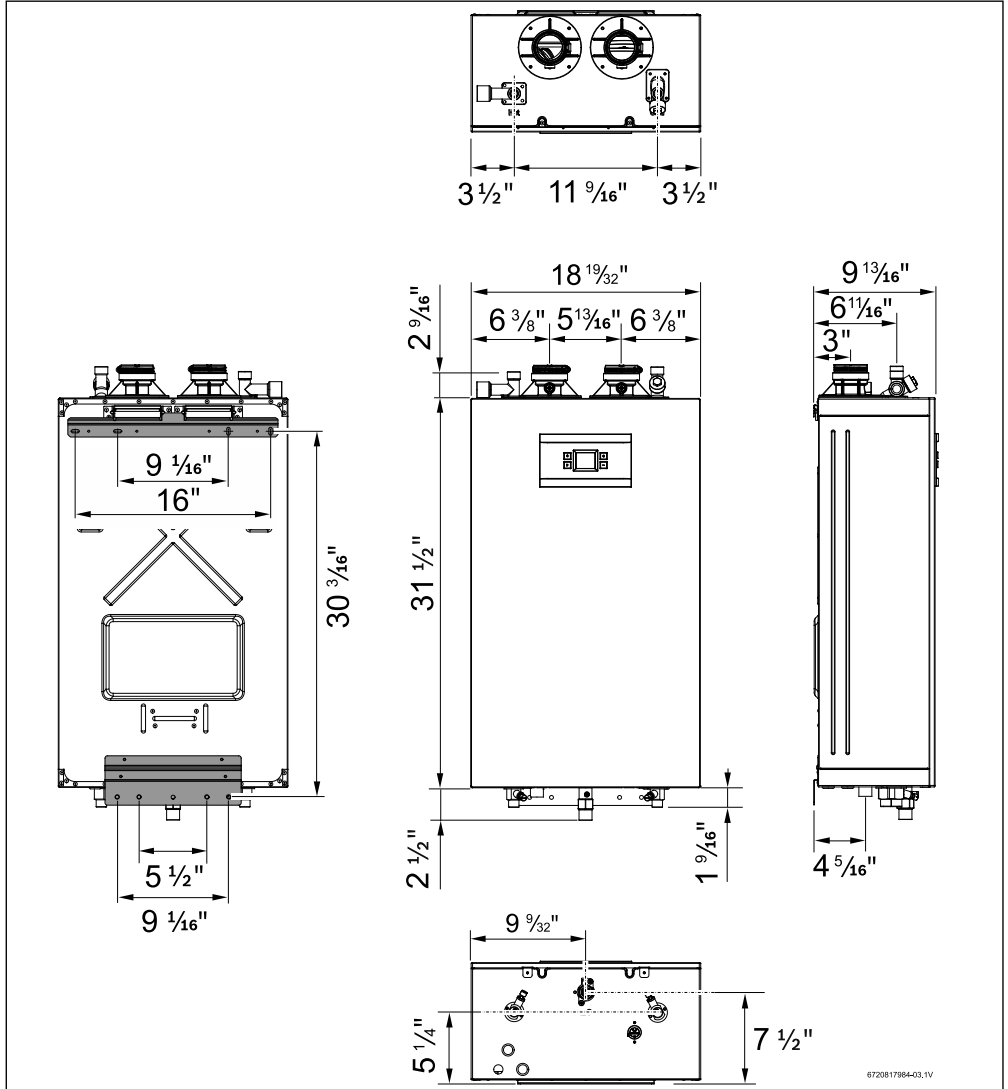

Fig. 5 Dimensions

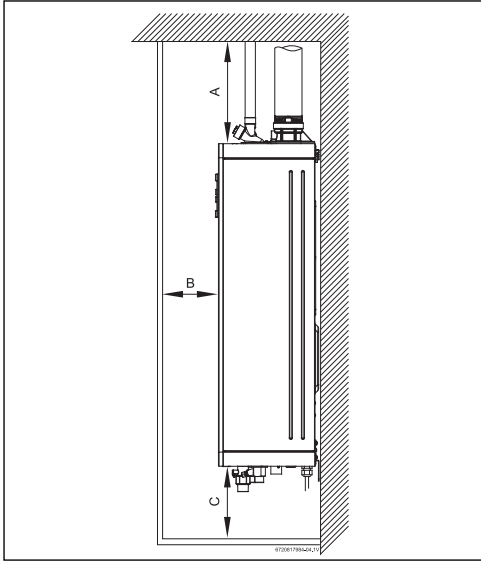

Fig. 6 Side view

	RTG-K-199/160N/X1
TOP (A)	12"
FRONT (B)	1"
BACK	0"
SIDES	1"
FLOOR (C)	12"

Table 4 Recommended minimum clearances



For servicing access, a 2ft clearance is recommended to the front cover.

4 Installation instructions

4.1 Installation tools

The following specialized tools may be required if converting from natural gas to LP:

- Pressure manometer
- Combustion Gas Analyzer (in case of gas type conversion and/or combustion noise troubleshooting)

4.2 Introduction

Please follow these instructions. Failure to follow instructions may result in:

- ▶ Damage or injury.
- ▶ Improper operation.
- ▶ Loss of warranty.



DANGER:

- ▶ The water heater must be installed by a qualified installer in accordance with these instructions. If improperly installed, a hazardous condition such as explosion or carbon monoxide poisoning could result. Manufacturer is not responsible for improperly installed appliances.



Common installation practice is to first determine the path and method of venting, then design the piping layout.

4.3 Proper location for installing your heater

Carefully select the location of the water heater. For your safety and for proper heater operation, you must provide combustion air to the heater and properly vent the exhaust gases.

Follow the guidelines below:

1. Locate the heater where venting, gas and plumbing connections are feasible and convenient.
2. The hot water lines should be kept short and insulated to save energy. It is recommended to locate the water heater as close as practical to the most frequently used hot water fixtures.

NOTICE:

Risk of appliance freezing!

- ▶ The water in this water heater is cold and always remains cold except for the times the burner is on. In the event of a power outage in conjunction with freezing temperatures, the heater should be drained.

See section 7.2, page 54 "Winterizing" for draining instructions.

NOTICE:

Installation and commissioning

- ▶ Do not install the water heater in rooms with a high moisture level (e.g. bathrooms, saunas).



WARNING:

- ▶ Flammable materials, gasoline, pressurized containers, or any other items or articles that are potential fire hazards must NOT be placed on or adjacent to the heater. The appliance area must be kept free of all combustible materials, gasoline and other flammable vapors and liquids.



WARNING:

Risk of blockage!

- ▶ Excess of solid particles (e.g. bugs, pollen) in the air intake may clog the air filter and lead to premature failure of the heater if not protected accordingly.
- ▶ Do not install the water heater in areas where excess of solid particles may accumulate.

4.4 Heater placement and clearances

The water heater design is approved for installation on a combustible wall (see chapter 4.5) provided the floor covering below the heater is noncombustible.

For installations in an alcove or closet, maintain the minimum clearances to combustible and non-combustible materials. See fig. 6, page 16.

4.5 Hanging appliance on the wall



WARNING:

Severe personal injury and property damage!

Before mounting appliance:

- ▶ Check that there are no loose or damaged parts inside the appliance.
- ▶ Set the heater gas type according to the gas supplied to the unit.



Front cover should be removed (see instructions on page 12) in order to inspect components visually.



WARNING:

- ▶ Do not install this appliance on a carpeted wall. The heater must be mounted on a wall using appropriate anchoring materials.

NOTICE:

Risk of appliance freezing!

- ▶ In areas where outside temperature is routinely below 32°F (0 °C) and the heater is to be installed on the inside of an exterior wall, provide a minimum 2" air gap or rigid insulation between the heater back and the wall.

If the wall is sheathed with plaster or drywall, it is recommended that two support boards, either 1"x 4" or 1/2" (minimum) plywood first be attached across a pair of studs, see fig. 7.

- ▶ Secure the wall mounting bracket provided with the heater to a wall surface. The heater must be kept level on the wall surface, see fig. 8, page 18.
- ▶ Hang the appliance on the bracket, see fig. 9.

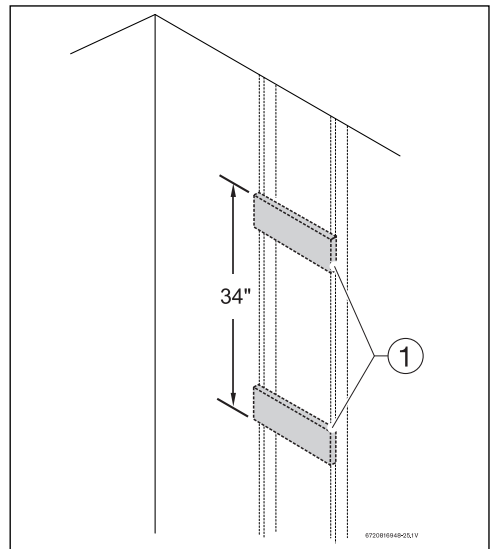

Fig. 7 Distance between support boards

[1] Support boards

Vertical studs are typically 16" (406mm) on center.

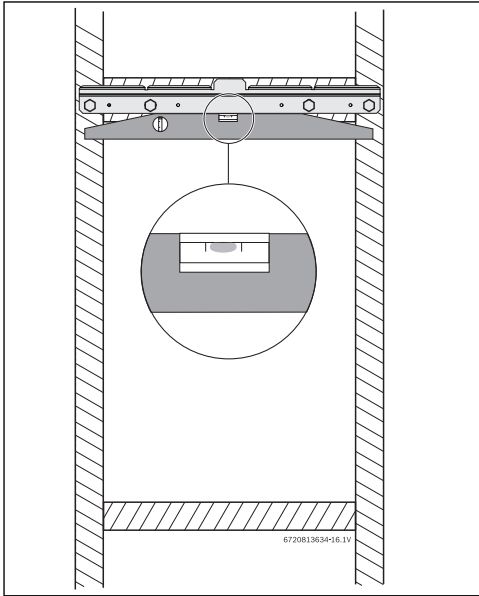

Fig. 8 Leveling wall mounting bracket

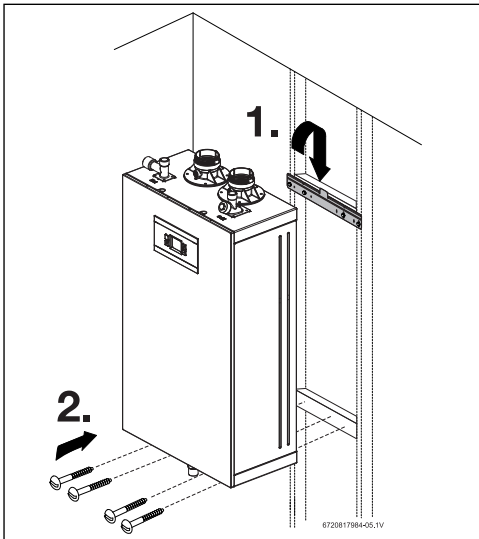

Fig. 9 Mounting the heater

CAUTION:

Personal injury and property damage.

- ▶ Appliance must be installed vertically.

4.6 Venting



DANGER:

Risk of CO poisoning!

- ▶ Do not reduce the exhaust or combustion air vent pipe sizes.
- ▶ Do not common vent with any other vented appliance or stove.
- ▶ Do not use Type-B vent as the actual exhaust vent system for the appliance.

DANGER:

Flue gas poisoning!

- ▶ Failure to vent the exhaust gases to the outside (see table 5 for proper material) may result in dangerous flue gases filling the structure in which it is installed.

NOTICE:

- ▶ Installations resulting in negative pressure/back draft require sealed combustion (twin pipe / concentric). Damage caused from back draft, ie. freezing, are not covered by warranty.

NOTICE:

Appliance malfunction!

- ▶ Protect the exhaust and inlet from leaves and debris by installing a screen on the end of the termination. ¼" mesh minimum opening recommended on screen.
- ▶ Do not install the water heater in areas where dust and chemicals like hair sprays, spray detergents, or chlorine may accumulate.



Flue temperature:

- ▶ To prevent the risk of flue material overheat the appliance's flue temperature is sensed and is limited. The flue temperature limit is depending on inlet water temperature.
- ▶ **Residential models:** Maximum flue temperature is limited to 145 °F.

4.6.1 Vent options

This appliance can be installed as direct vent or Category IV. The RTG-K-199/160N/X1 is approved with the following venting options:

Item	Material		United States	Canada
Vent or air intake pipe and fitting	PP	flexible	M&G / DuraventCentrotherm	Thermoplastic vent pipe must be certified to ULC S636. Air Intake pipe may be of any material listed (left)
		concentric		
		rigid		
	PVC	schedule 40	ANSI/ASTM D1785	
	PVC-DWV		ANSI/ASTM D2665	
	CPVC	schedule 40	ANSI/ASTM F441	
ABS-DWV	schedule 40	ANSI/ASTM D2661		
Pipe cement / primer	PVC		ANSI/ASTM D2564	
	CPVC		ANSI/ASTM F493	
	ABS		ANSI/ASTM D2235	

Table 5 Approved vent materials

For specific questions concerning vent material, specifications, usage or installation, please contact the vent manufacturer directly.

Approved Vent Manufacturers:

- M&G
- Centrotherm
- IPEX
- Royal Plastics
- Eccovent
- Charlotte
- Z-flex

the exhaust adapter. The exhaust pipe must be properly supported and must be pitched a minimum of a ¼ inch per foot back to the appliance. This allows the condensate to drain properly.













Maximum vent lengths and equivalent lengths per table 8 apply.





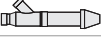

Do not use cellular foam core pipe for exhaust. Approved for intake only.

The vent connection for the appliance is secured with a clamp on the appliance exhaust adapter. All other vent connections must be glued, except PP and flex PP. Slide the vent pipe into



4.6.2 Approved vent components and terminations

Manufacturer	Manufacturer part number	Product description	Diagram	Horizontal	Vertical	Equivalent Lengths (Ft.)
Bosch	196050 196051 196052	2" Bird screen 3" Bird screen 4" Bird screen		■	■	2
-	-	2", 3", and 4" SCH40 (Solid Core) PVC/CPVC 45° long sweep elbow		■	■	2.5
-	-	2", 3", and 4" SCH40 (Solid Core) PVC/CPVC 45° short sweep elbow		■	■	2.5
-	-	2", 3", and 4" SCH40 (Solid Core) PVC/CPVC 90° short/long/extra long, sweep elbow ¹⁾		■	■	5
-	-	2", 3", and 4" SCH 40 (Solid Core) PVC/CPVC "T" terminal w/vent screen		■	■	10
-	-	2", 3" and 4" SCH40 (Solid Core) PVC/CPVC straight pipe		■	■	1
IPEX	196005	PVC Concentric termination (2" by 16" long)		■	■	Exhaust: 1.5 Intake: 20
IPEX	196105	PVC Concentric termination (2" by 28" long)		■	■	Exhaust: 2.5 Intake: 20
IPEX	196125	PVC Concentric Termination Kit (2" by 40" long)		■	■	Exhaust: 3 Intake: 20
IPEX	196006 / 197009	PVC / CPVC Concentric Termination Kit (3" by 20" long)		■	■	Exhaust: 1.5 Intake: 40
IPEX	196106 / 197107	PVC / CPVC Concentric Termination Kit (3" by 32" long)		■	■	Exhaust: 2 Intake: 40
IPEX	196116 / 197117	PVC / CPVC Concentric Termination Kit (3" by 34" long)		■	■	Exhaust: 2 Intake: 40
IPEX	196021 / 197021	PVC / CPVC Concentric Termination Kit (4" by 36" long)		■	■	Exhaust: 2 Intake: 60
IPEX	196984 196985 196986	2" PVC Low profile termination kit 3" PVC Low profile termination kit 4" PVC Low profile termination kit		■		Exhaust: 0 Intake: 5

Manufacturer	Manufacturer part number	Product description	Diagram	Horizontal	Vertical	Equivalent Lengths (Ft.)
IPEX	081216 081219	2" PVC Wall Termination Kit 3" PVC Wall Termination Kit		■		Exhaust: 15 Intake: 7.5
Temple industries	ECAP 321	2" PVC termination E-Cap 3" PVC termination E-Cap			■	2 4
Royal Plumbing Solutions	52CVKGV6502	2" GVS-65 Concentric Vent Termination Kit		■	■	Exhaust: 2 Intake: 20
Royal Plumbing Solutions	52CVKGV6503	3" GVS-65 Concentric Vent Termination Kit		■	■	Exhaust: 2 Intake: 40
Royal Plumbing Solutions	52SWVKGVS6502 (2")	GVS-65Side Wall Vent Termination Kit		■		Exhaust: 0 Intake: 5

1) Close sweep fittings are not accepted.

Table 6 Approved PVC/CPVC Vent Components & Terminations

Manufacturer	Manufacturer part number	Product description	Diagram	Horizontal	Vertical	Equivalent Lengths (Ft.)
Duravent M&G	810009685 810009713 810009745	2" PP Twin pipe termination 3" PP Twin pipe termination 4" PP Twin pipe termination		■		Exhaust: 2 Intake: 2
Duravent M&G	810009684 810009712	2" PP Single Horizontal Termination 3" PP Single Horizontal Termination		■		6
Duravent M&G	810009682 810009710	(2" x 4") PP Horizontal Termination Kit - Concentric (3" x 5") PP Horizontal Termination Kit - Concentric		■		Exhaust: 20 Intake: 40

Installation instructions











Manufacturer	Manufacturer part number	Product description	Diagram	Horizontal	Vertical	Equivalent Lengths (Ft.)
Duravent M&G	810009692	(2" x 4") Black PP Vertical Termination Kit - Concentric			■	Exhaust: 20 Intake: 40
	810009720	(3" x 5") Black PP Vertical Termination Kit - Concentric				
	810009693	(2" x 4") Terra-Cotta PP Vertical Termination Kit - Concentric				
	810009721	(3" x 5") Terra-Cotta PP Vertical Termination Kit - Concentric				
Centro- therm	ISLPT0202	2" Low profile Wall Termination			■	Exhaust: 0 Intake: 5
	ISLPT0303	3" Low profile Wall Termination				
Centro- therm	ICRT2439	2" x 4" Concentric Roof Termination			■	Exhaust: 5 Intake: 5
Centro- therm	ICRT3539	3" x 5" Concentric Roof Termination			■	Exhaust: 10 Intake: 10
Centro- therm	ICWT242	2" x 4" Concentric Wall Termination			■	Exhaust: 4 Intake: 4
Centro- therm	ICWT352	3" x 5" Concentric Wall Termination			■	Exhaust: 6 Intake: 6
Ecco Manu- facturing	190288	2" PP Concentric Terminations Horizontal (Wall) Terminations			■	Exhaust: 4 Intake: 4
Ecco Manu- facturing	190388	3" PP Concentric Terminations Horizontal (Wall) Terminations			■	Exhaust: 6 Intake: 6
Ecco Manu- facturing	190295	2" PP Vertical (Roof) Terminations			■	Exhaust: 4 Intake: 4
Ecco Manu- facturing	190395	3" PP Vertical (Roof) Terminations			■	Exhaust: 8 Intake: 8

Table 7 Approved PP Vent Components & Terminations

4.6.3 Vent specifications

Establish vent clearances that comply with the vent manufacturer's specifications and all applicable national/local codes.

Minimum combustion air and exhaust pipe length

The minimum exhaust pipe length is 1 foot (0.3m) of straight vent pipe. The minimum combustion air pipe length is one 1 ft or one 90° elbow or an air intake grill cap to prevent debris from falling into the appliance.

Maximum combustion air and exhaust pipe length

Table 8 displays the maximum allowable straight pipe lengths for combustion air and exhaust piping. Reduce the maximum allowable pipe length by the equivalent lengths for each elbow used and termination used.



PROPER GAS PRESSURE!

The following section assumes the water heater will receive gas pressure greater than or equal to 5" WC for the 199kBTU models (4" WC for 160kBTU models). In cases of gas pressure below 5" WC for the 199kBTU (4" WC for the 160kBTU models) the maximum heat input is reduced.



The values of maximum flue length in table 8 are before any deductions for elbows or terminations.

Venting	Max equivalent Exhaust length	Max equivalent Intake length
2" Twin pipe	60ft ¹⁾	60ft
3" Twin pipe	280ft ¹⁾	280ft
2"/ 4" Concentric pipe	60ft ¹⁾	
3"/ 5" Concentric pipe	280ft ¹⁾	

1) To assure maximum heat input at maximum vent length minimum gas pressure should be 5" W.C. for the 199 kBTU models and 4" W.C. for the 160 kBTU models.

Table 8 Maximum Allowable Exhaust and Combustion Air Lengths



Improper gas pressure or vent length may result in undesired symptoms or errors such as noisy burner, C1, C2, CF, EA, EC.

The vent for this appliance shall not terminate:

1. over public walkways; or
2. near soffit vents or crawl space vents or other areas where condensate or vapor could create a nuisance or hazard or cause papery damage; or
3. where condensate vapor could cause damage or could be detrimental to the operation of regulators, relief valves, or other equipment.

Required direct vent terminal clearances (twin pipe / concentric penetration)

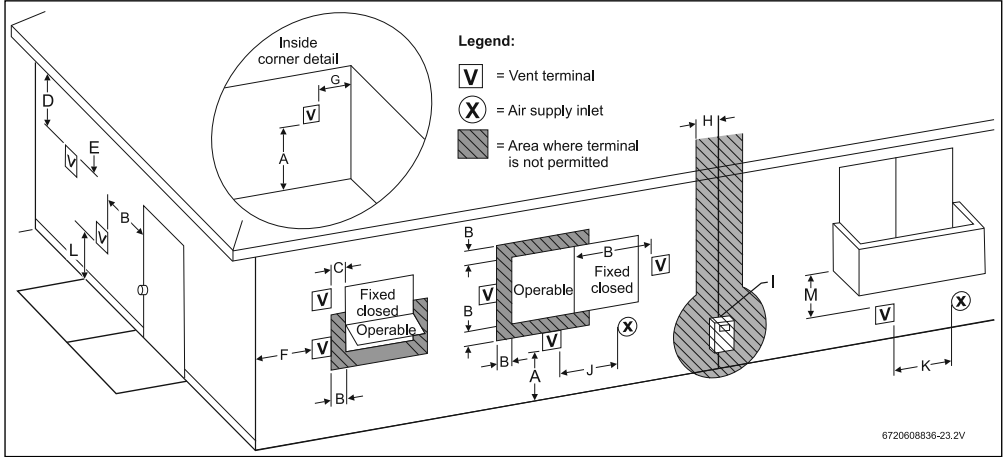

Fig. 10

		Canadian installations ¹⁾ with direct vent terminals	U.S. installations ²⁾ with direct vent terminals
A	Clearance above grade, veranda, porch, deck or balcony	12 in. (30cm)	12 in. (30cm)
B	Clearance to window or door that may be opened	36 in. (91cm)	12 in. (30cm) below or to side of opening; 12 in. (30cm) above opening.
C	Clearance to permanently closed window	*	*
D	Vertical clearance to ventilated soffit located above the terminal within a horizontal distance of 2 ft (61cm) from the center line of the terminal.	*	*
E	Clearance to unventilated soffit	*	*
F	Clearance to outside corner	*	*
G	Clearance to inside corner	*	*
H	Clearance to each side of center line extended above meter/regulator assembly	36 in. (91cm) within a height 15 ft (4.6m) above the meter/ regulator assembly	*
I	Clearance to service regulator vent outlet	36 in. (91cm)	*
J	Clearance to nonmechanical air supply inlet to building or the combustion air inlet to any other appliance.	36 in. (91cm)	12 in. (30cm)
K	Clearance to a mechanical air supply inlet	6 feet (1.83m)	36 in. (91cm) above if within 10 ft (3m) horizontally

		Canadian installations ¹⁾ with direct vent terminals	U.S. installations ²⁾ with direct vent terminals
L	Clearance above paved sidewalk or paved driveway located on public property	7 ft (2.13m) ³⁾	*
M	Clearance under veranda, porch deck or balcony	12 in. (30cm) ⁴⁾	*

- 1) In accordance with the current CSA B149.1 Natural Gas and Propane Installation Code.
- 2) In accordance with the current ANSI Z223.1 / NFPA 54, National Fuel Gas Code.
- 3) A vent shall not terminate directly above a sidewalk or paved driveway that is located between two single family dwellings and serves both dwellings.
- 4) Permitted only if veranda, porch, deck or balcony is fully open on a minimum of two sides beneath the floor.

Table 9

[*] Clearance in accordance with local installation codes and the requirements of the gas supplier.

Required other than direct vent terminal clearances (single pipe penetration)

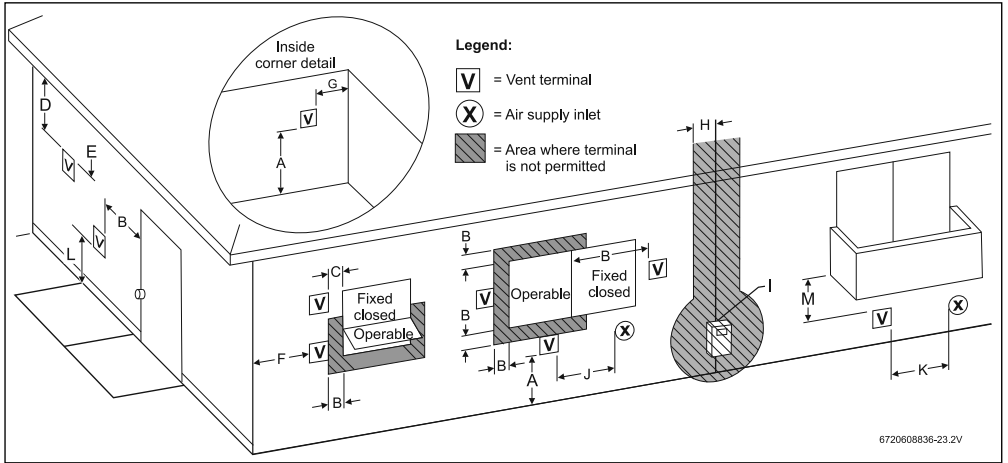

Fig. 11

		Canadian installations ¹⁾ with non direct vent terminals	U.S. installations ²⁾ with non direct vent terminals
A	Clearance above grade, veranda, porch, deck or balcony.	12 in. (30cm)	12 in. (30cm)
B	Clearance to window or door that may be opened.	36 in. (91cm)	48 in. (1.2 m) below or to side of opening; 12 in. (30cm) above opening)
C	Clearance to permanently closed window	*	*
D	Vertical clearance to ventilated soffit located above the terminal within a horizontal distance of 2 feet (61cm) from the center line of the terminal	*	*
E	Clearance to unventilated soffit	*	*
F	Clearance to outside corner	*	*
G	Clearance to inside corner	*	*
H	Clearance to each side of center line extended above meter/ regulator assembly	36 in. (91cm) within a height 15 ft (4.6m) above the meter/ regulator assembly	*
I	Clearance to service regulator vent outlet	36 in. (91cm)	*
J	Clearance to nonmechanical air supply inlet to building or the combustion air inlet to any other appliance	36 in. (91cm)	48 in. (1.2m) below or to side of opening; 1 ft (300mm) above opening
K	Clearance to mechanical air supply inlet	6 ft (1.83 m)	36 in. (91cm) above if within 10 ft (3m) horizontally

		Canadian installations ¹⁾ with non direct vent terminals	U.S. installations ²⁾ with non direct vent terminals
L	Clearance above paved sidewalk or paved driveway located on public property	7 ft (2.13m) ³⁾	*
M	Clearance under veranda, porch deck or balcony	12 in (30cm) ⁴⁾	*

- 1) In accordance with the current CSA B149.1 Natural Gas and Propane Installation Code.
- 2) In accordance with the current ANSI Z223.1 / NFPA 54 National Fuel Gas Code.
- 3) A vent shall not terminate directly above a sidewalk or paved driveway that is located between two single family dwellings and serves both dwellings.
- 4) Permitted only if veranda, porch, deck or balcony is fully open on a minimum of two sides beneath the floor.

Table 10

[*] Clearance in accordance with local installation codes and the requirements of the gas supplier.

4.6.4 Vent configuration examples for PVC systems

Below are approved examples of vertical and horizontal venting installations.

NOTICE:

Using a single pipe vent in cold climates puts the water heater at risk of freezing, as negative air pressure is common in buildings during cold weather. This situation will pull cold air through the heat exchanger and can lead to damage and a water leak and is not covered by the product's warranty. In the event of negative air pressure causing back drafting contact Bradford White for information.

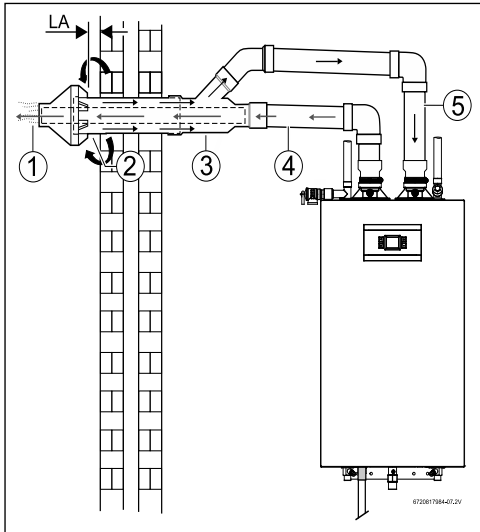

Fig. 12 Horizontal venting system (concentric vent)

- [1] Exhaust
- [2] Air intake
- [3] Concentric Vent Kit
- [4] Exhaust pipe
- [5] Intake pipe
- [6] Minimum 1"

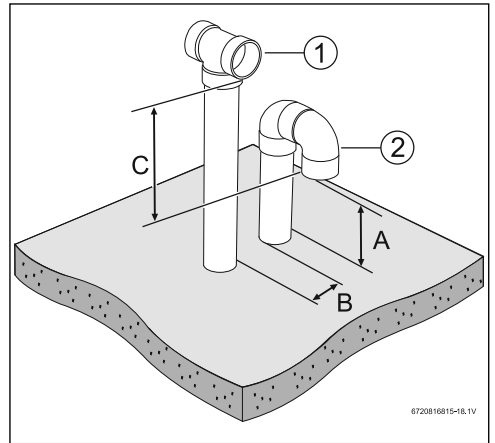

Fig. 13 Vertical venting system

- [1] Exhaust
- [2] Intake
- [A] 12 inches (305 mm) (18 in. for Canada) above maximum snow level or at least 24 inches (610 mm), whichever is greater.
- [B] 12 inches (305 mm)
- [C] 12 inches (305 mm) minimum above air intake opening

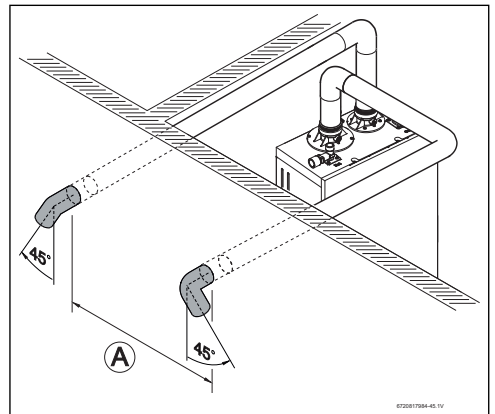

Fig. 14 Horizontal parallel venting system (twin pipe)

- [A] 3ft minimum



Vent terminals are at the same height.

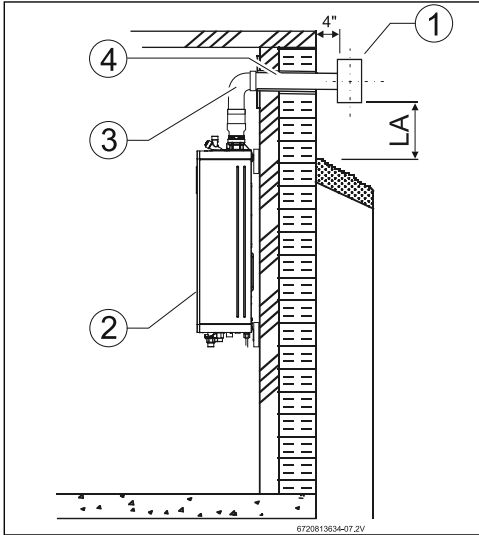

Fig. 15 Horizontal venting installation (combustion air piping not shown)

- [1] Termination
- [2] Water heater
- [3] Elbow
- [4] Horizontal run should slope $\frac{1}{4}$ " per foot upwards to water heater.
- [LA] 12 inches (305 mm) (18 in. for Canada) above maximum snow level or at least 24 inches (610 mm), whichever is greater.

NOTICE:

- ▶ Place pipe supports every 5 feet (1525mm) of horizontal and vertical run, beginning with support near water heater.
- ▶ Periodic cleaning of the vent terminal and air-intake screens is mandatory.
- ▶ Avoid locating vent terminals near equipment, vegetation, plants or building features which can be subject to degradation from exhaust gases.

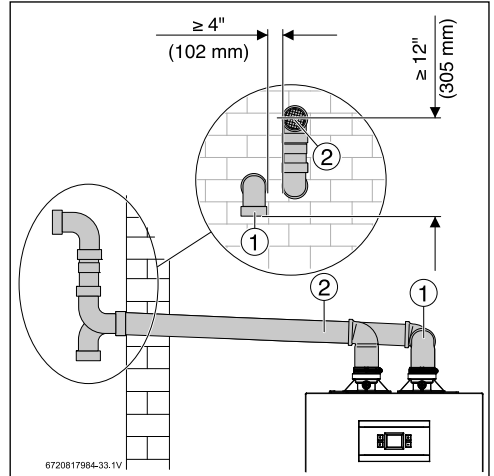

Fig. 16 Horizontal venting system (sealed combustion)

- [1] Intake
- [2] Exhaust

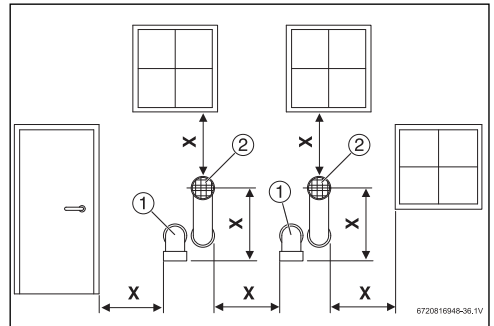

Fig. 17 Vent and combustion air pipe position of a sealed combustion system

- [1] Intake
- [2] Exhaust
- [X] At least 1 foot (305mm)

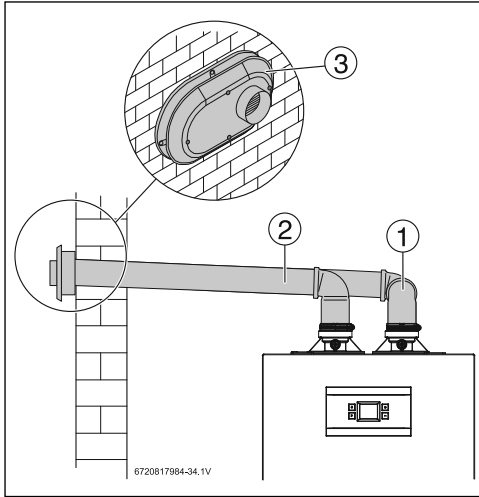

Fig. 18 Horizontal venting system (sealed combustion)

- [1] Intake
- [2] Exhaust
- [3] Termination

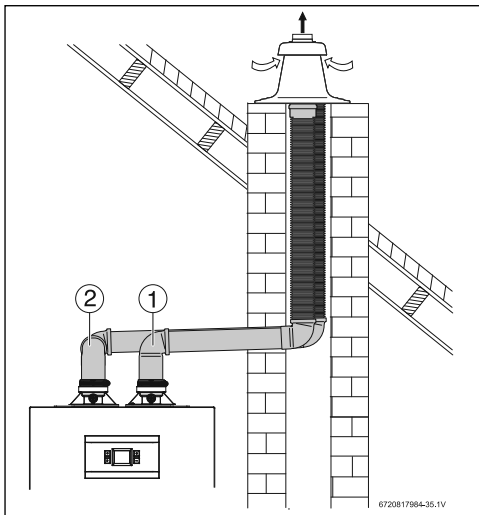

Fig. 19 Vertical venting system with flex PP (sealed combustion)

- [1] Intake
- [2] Exhaust



With Flex Pipe the maximum length is reduced by 60%, (applies only to the section in flex PP). Example: 10 feet of flex PP is equivalent to 25 feet of rigid PP.

Flex Pipe according to the suppliers instructions is for use in the vertical part of the installation only.

4.6.5 Connecting the condensate water drain

NOTICE:

Risk of condensate pipe freezing!

- ▶ Do not install condensate drain tubing in areas where it may freeze.

Appliance condensate drain installation

The appliance comes equipped with an internal condensate drain and siphon. This drains condensation formed in the secondary heat exchanger. Piping must be installed under the condensate drain outlet on the water heater and piped for disposal in accordance with local codes.

To install the condensate drain, connect a 3/4" NPT adapter on the water heater.

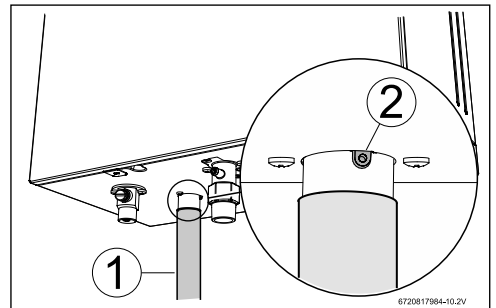

Fig. 20 Appliance drain installation

- [1] Drain connection
- [2] Breather

Installing an additional breather downstream is not necessary since this function is already included in the heater.

NOTICE:

A blocked breather may cause an undesired double-siphon effect.

- ▶ Ensure that the breather included in the siphon is not obstructed to allow correct function.



Verify condensate disposal/neutralization is in accordance with federal, State, and local regulation.



This is a high efficiency appliance, condensate flow can be as much as 2.1 gal/hr at full power.

4.6.6 Backdraft reducer

The backdraft reducer (9301BFP) is the preferred option for limiting backdraft (see fig. 21).



The backdraft reducer (9301BFP) is sized for 3" diameter PVC.



It is possible to use Backdraft reducer (9301BFP) for 2" installations. This requires 2" to 3" adapters.

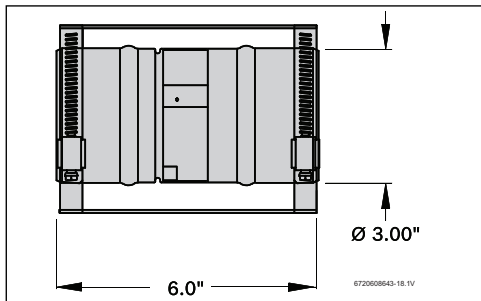

Fig. 21 Part # 9301BFP

Installation

For this solution to be effective, the internal flapper must be 100% closed when the water heater is not running. Refer to fig. 23 for preferred installation positions in the vent system.

Installation requirements:

- ▶ Install the damper per the supplied manufacturer's instructions.
The damper is only to be used in the exhaust vent piping.

- ▶ Ensure directional arrow on damper label faces in the same direction as exhaust flow.
- ▶ If installed horizontally, the axis must be horizontal or slightly pitched up towards termination to ensure damper closes 100% when heater is not running.
- ▶ To allow accessibility, the damper must not be installed in an enclosed section of vent pipe.
- ▶ Do not install the damper in unconditioned spaces (e.g. attics) Condensation can build up while the heater is running which can later freeze and potentially block the flapper.

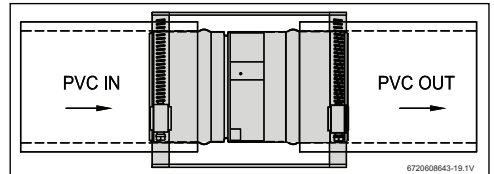

Fig. 22 Backflow reducer (9301BFP) installed

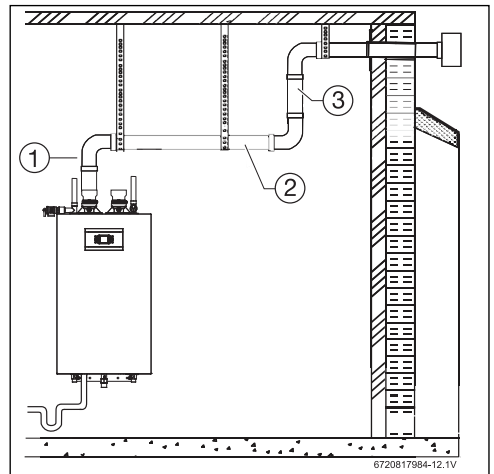

Fig. 23 Installation Recommendation for Placement of Backdraft reducer

- [1] Good
- [2] Better
- [3] Best

4.6.7 Single Pipe Venting

NOTICE:

- ▶ Single pipe venting not recommended in cold climates.
 - ▶ Installations resulting in negative pressure/back draft require sealed combustion (twin pipe / concentric).
 - ▶ Damage caused from back draft, ie. freezing, is not covered by warranty.
-

NOTICE:

- ▶ When installed in an environment where corrosive chemicals or dirty air (e.g. hair salons, car washes) are present the sealed combustion (twin pipe or concentric) is required.
-

Air Combustion



WARNING:

Risk of CO poisoning!

The lack of adequate air openings may lead to improper operation due to other appliances consuming requires air.

- ▶ Always follow local codes and regulations of authority having jurisdiction in case of single pipe installation in confined spaces.
-

Although it is permissible to draw the air-intake from the inside, it is not the manufacturer's recommended installation method. When drawing inside air, install a 90° elbow or air intake screen on the top of the air-intake inlet adaptor to prevent foreign objects from falling into the unit.

If a single pipe installation is utilized, follow guidelines below for providing adequate combustion air for the water heater as well as any other appliances that may consume air in the same space. Always follow local codes and regulations of the authority having jurisdiction.

• Appliances located in unconfined spaces:

- **a)** An unconfined space is one whose volume is greater than 50 cubic feet (1.42 cubic meter) per 1000 BTU/hr (292.81 Watts) of the combined rating of all appliances installed in the space. That would be 9950 cubic feet (281.8 cubic meters) or 1243 square feet with 8 foot ceiling for a single 199 kBTU water heater.
- **b)** In unconfined spaces in buildings of conventional frame, masonry, or metal construction, infiltration air is normally adequate to provide air for combustion.

• Appliances located in confined spaces:

The confined space must be provided with two permanent openings, one commencing within 12 inches (304.8mm) of the top and one commencing within 12 inches (304.8mm) of the bottom of the enclosure. Each opening must have a minimum free area of one square inch per:

- 1000 BTU/hr (292.81 Watts) if all air is taken from inside the building
- 2000 BTU/hr (585.62 Watts) if all air is taken from the outside by horizontal ducts
- 4000 BTU/hr (1171.24 Watts) if all air is taken from the outside by direct openings or vertical ducts

Or the confined space must be provided with one permanent opening or duct that is within 12 inches (304.8mm) of the ceiling of the enclosure. This opening must have a minimum free area of one square inch per:

- 3000 BTU/hr (878.43 Watts) if all air is taken from the outside by a direct opening or vertical duct.

Louvers, grills and screens have a blocking effect; when used, increase the sizes of your openings by 300% for wood louvers (as wood type will reduce the free air by 75%) and 43% for metal louvers (as metal will reduce the free air by 30%). Refer to the National Fuel Gas Code for complete information.

4.7 Factory settings

The appliances are supplied having been set in the factory for the values shown on the rating plate for natural gas. For any other adjustments see chapter 6.7.1.

4.7.1 Natural gas



The appliances must not be operated if the dynamic gas pressure is less than 3.5" WC¹⁾ or greater than 10.5" WC.

4.7.2 Liquid propane gas (after gas conversion)



The appliances must not be operated if the dynamic gas pressure is less than 8" WC or greater than 13" WC.

If gas conversion is needed (**Natural Gas to Liquid propane Gas**), see section 6.7.1.



! DANGER:

- ▶ The gas type conversion must only be carried out by a qualified contractor.

4.8 Gas piping & connections



Before connecting the gas supply, check the rating plate on the right side of the heater to be sure that the heater is rated for the same gas to which it will be connected.

In the United States: The installation must conform with local codes or, in the absence of local codes, the National Fuel Gas Code ANSI Z223.1/NFPA 54.

In Canada: The installation must conform to CGA B149 INSTALLATION CODES and/or local installation codes.



! DANGER:

Explosion hazard!

- ▶ DO NOT connect to an unregulated or high pressure propane line or to a high pressure commercial natural gas line.



DANGER:

Explosion hazard!

- ▶ The heater must be isolated from the gas supply piping system during any pressure testing of that system at test pressures equal to or more than 0.5 psig (14 W.C.). If overpressure has occurred, such as through improper testing of the gas lines or malfunction of the supply system, the gas valve must be checked for safe operation.

GAS CONNECTIONS

- ▶ Install a manual gas shut off valve on the gas supply line within easy reach of the appliance.
- ▶ Install a union when connecting gas supply.
- ▶ Gas connection to the water heater is ¾" NPT. See chapter 4.8.1 for the minimum internal pipe diameter required.
- ▶ Undersized flexible appliance connector not permitted.
- ▶ National Fuel Gas Code requires that a sediment trap (drip leg) be installed on gas appliances not so equipped. The drip leg must be accessible and not subject to freezing conditions. Install in accordance with the recommendations of the serving gas supplier, see fig. 25.
- ▶ Tighten gas pipe with the support of a wrench, see fig. 24.

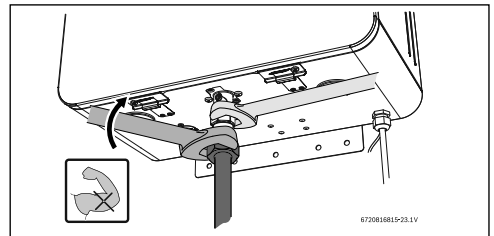

Fig. 24 Tighten gas pipe to the heater

- 1) To assure maximum heat input at maximum vent length minimum gas pressure should be 5" W.C. for the 199 kBTU models and 4" W.C. for the 160 kBTU models. For more information see section 4.6.3.

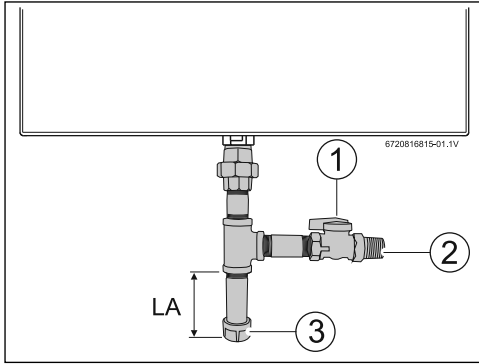

Fig. 25 Gas connection

[1] Shut off valve

[2] Gas supply

[3] Cap

[LA] Minimum 3" sediment trap, (drip leg)

Once connections are made, check for gas leaks at all joints.

Apply some gas leak detection solution to all gas fittings.

Bubbles are a sign of a leak. A combustible gas detector may also be used to detect for leaks.



DANGER:

Explosion hazard!

- If you detect a gas leak, shut off the gas and ventilate the room (open windows, doors). Tighten appropriate fittings to stop leak. Turn the gas on and check again with a gas leak detection solution. Never test for gas leaks using a match or flame.

GAS LINE SIZING

The gas supply piping for a single heater should be sized for a maximum draw of 199000 BTU/hr for the RTG-K-199N/X1.

Measure the length of the gas supply line from the building's gas main to the heater and use section 4.8.1 and 4.8.2, page 35 or the gas line manufacturer's sizing tables to determine the pipe diameter necessary. If there are more gas appliances on the line, size the gas line according to the total maximum amount of BTU draw input rating for all appliances combined.

Note: Undersizing the gas line may result in diminished hot water flow rate and temperature, or improper appliance operation (noise and combustion instabilities). See section 4.15, page 43 for the procedure to measure gas pressure. Proper gas pressure must be confirmed at time of installation.

4.8.1 Gas Line Sizing Tables for NATURAL GAS

For your convenience see below for an excerpt from gas line sizing tables for a single NG appliance. For details see the current NFPA 54.

Required input for 160000 / 199000 BTU/hr for the RTG-K-160/199N/X1. The gas supply system must be sized for the combined total maximum BTU/hr load requirements of all gas appliances running simultaneously.

The tables below show the maximum capacity of the gas supply pipe in cubic feet per hour. Please contact your local gas supplier for the energy content of the gas to determine the BTU/hr capacity. Use 1,000 BTU/cubic foot for rough estimations.

Initial Supply Pressure of 8.0" w.c. or Greater											
Nominal Iron Pipe Size, inches	Internal Diameter inches	Length of Black Iron Pipe (Schedule 40 Metallic Pipe), Feet									
		10	20	30	40	50	60	70	80	90	100
¾	0.824	360	247	199	170	151	137	126	117	110	104
1	1.049	678	466	374	320	284	257	237	220	207	195

Table 11 Maximum pipe capacity in cubic feet of Natural Gas per hour for gas pressures of <2.0 psig (55" WC or 138 mbar) and a pressure drop of 0.5" W.C. (1.25 mbar) based on 0.60 specific gravity gas).

Initial Supply Pressure of 8.0" w.c. or Greater											
Nominal Iron Pipe Size, inches	Internal Diameter inches	Length of Black Iron Pipe (Schedule 40 Metallic Pipe), Feet									
		10	20	30	40	50	60	70	80	90	100
½	0.622	454	312	250	214	190	172	158	147	138	131
¾	0.824	949	652	524	448	397	360	331	308	289	273
1	1.049	1790	1230	986	844	748	678	624	580	544	514

Table 12 Maximum pipe capacity in cubic feet of Natural Gas per hour for gas pressures of <2.0 psig (55" WC or 138 mbar) and a pressure drop of 3.0" W.C. (7.5 mbar) based on 0.60 specific gravity gas).

Initial Supply Pressure of 8.0" w.c. or Greater											
Length of Corrugated Stainless Steel Tubing (CSST), Feet											
EHD*	10	20	30	40	50	60	70	80	90	100	
30	330	231	188	162	144	131	121	113	107	101	
31	383	269	218	188	168	153	141	132	125	118	
37	639	456	374	325	292	267	248	232	219	208	

Table 13 Maximum pipe capacity in cubic feet of Natural Gas per hour for gas pressures of <2.0 psig (55" WC or 138 mbar) and a pressure drop of 0.5" W.C. (1.35 mbar) based on 0.60 specific gravity gas).

* EHD = Equivalent Hydraulic Diameter. The greater the value of EHD, the greater the gas capacity of the tubing.

4.8.2 Gas Line Sizing Tables for LP GAS

For your convenience, see below an excerpt from gas line sizing tables for a single LP appliance. Their intended use is for pipe sizing between the 2nd stage (low pressure) regulator and the appliance. For details, see the current NFPA 54 or NFPA 58.

Required input for 160000 / 199000 BTU/hr for the RTG-K-160/199N/X1. The gas supply system must be sized for the combined total maximum BTU/hr load requirements of all gas appliances running simultaneously.

Pipe Sizing Between Single- or Second-Stage (Low-Pressure) Regulator and Appliance									
Nominal Iron Pipe inches	Internal Diameter inches	Length of Black Iron Pipe (Schedule 40 Metallic Pipe), Feet							
		10	20	30	40	50	60	80	100
1/2	0.622	291	200	160	137	122	110	101	94
3/4	0.824	608	418	336	287	255	231	212	197
1	1.049	1150	787	632	541	480	434	400	372

Table 14 Maximum capacity of the gas supply pipe in thousands of BTU per hour of Undiluted LP Gas at 11" W.C (0.4 psig or 27.4mbar) based on a pressure drop of 0.5" W.C (1.25mbar).

CSST Sizing Between Single- or Second-Stage (Low-Pressure) Regulator and Appliance Shutoff Valve										
EHD*	Length of Corrugated Stainless Steel Tubing (CSST), Feet									
	10	20	30	40	50	60	70	80	90	100
23	254	183	151	131	118	107	99	94	90	85
25	303	216	177	153	137	126	117	109	102	98
30	521	365	297	256	227	207	191	178	169	159
31	605	425	344	297	265	241	222	208	197	186

Table 15 Maximum capacity in thousands of BTU of the gas supply pipe per hour of Undiluted LP Gas at 11" W.C (0.4 psig or 27.4mbar) based on a pressure drop of 0.5" W.C (1.25 mbar).

* EHD = Equivalent Hydraulic Diameter. The greater the value of EHD, the greater the gas capacity of the tubing.

Tube Sizing Between Single- or Second-Stage (Low-Pressure) Regulator and Appliance						
Nominal tube, inches	Internal Diameter inches	Length of Semirigid Copper Tubing, Feet				
		10	20	30	40	50
1/2	0.527	188	129	104	89	79
5/8	0.652	329	226	182	155	138

Table 16 Maximum capacity in thousands of BTU of the gas supply pipe per hour of Undiluted LP Gas at 11" W.C (0.4 psig or 27.4mbar) based on a pressure drop of 0.5" W.C (1.25 mbar).

* Source National Fuel Gas Code NFPA 54, ANSI Z223.1 - No Additional Allowance is necessary for an ordinary number of fittings.

4.9 Water quality

Water quality can have an impact on appliance longevity. Water supplied to the Infiniti Tankless™ K-Series must be in accordance with table 17 and fig. 26.

For water analysis data call your local water department, or if on a well, have well water analyzed periodically. Heavy scale will form if the combination of water total hardness and pH exceeds the values specified in fig. 26 (grey area), Bradford White recommends consulting a local water treatment professional for water softening/conditioning options.

Description	Max. Levels	
pH	pH	6.5 - 8.5
TDS (total Dissolved Solids)	mg/l or ppm	690
Total hardness	mg/l or ppm	200
Aluminum	mg/l or ppm	2.0
Chlorides	mg/l or ppm	250
Copper	mg/l or ppm	1.0
Iron	mg/l or ppm	0.3
Manganese	mg/l or ppm	0.05
Zinc	mg/l or ppm	5.0

Table 17

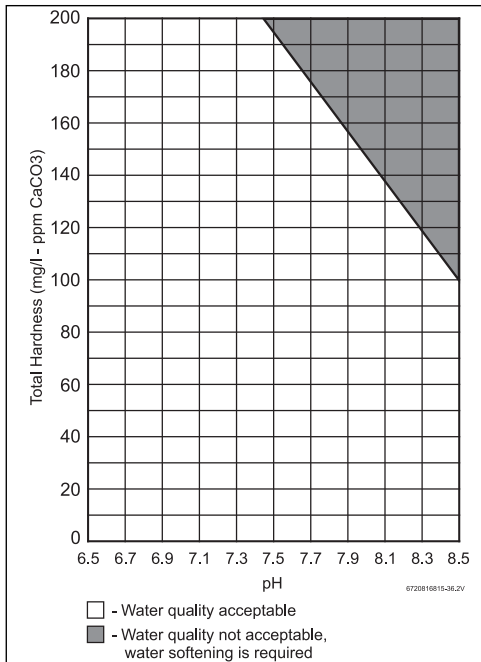

Fig. 26 Water total hardness and pH values

1. Total Hardness and pH maximum values must be evaluated in combination. Indicated maximum values will be reduced according to fig. 26.
2. Combined values of total hardness and pH must be under the indicated grey area. (e.g. the pair [180;8.3] [total hardness; pH] is not acceptable).

Connecting the pressure relief valve (PRV)

A pressure relief valve is included in the box and must be installed at the time of installation. No valve is to be placed between the PRV and the heater. No reducing coupling or other restriction may be installed in the discharge line. The discharge line must be a minimum of 4" above a drain and installed such that it allows complete drainage of both the PRV and the line. The discharge line must be placed where it will not cause any damage.

- ▶ Use the integrated port to install the PRV, see Fig. 27 [1].
- ▶ Tighten the PRV with the support of a wrench, see Fig. 27.
- ▶ Support all piping.

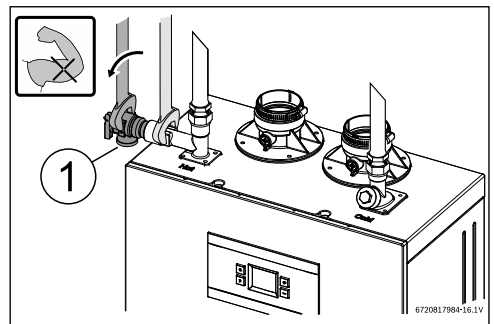

Fig. 27 Plumbing Connections (with shutoff valves) and Pressure Relief Valve

4.10 Water connections



Water connections are on top ONLY. Bottom connections are drain/service ports with limited flow capacity.

NOTICE:

- ▶ This heater is not approved for preheated water applications exceeding 140 °F (60 °C) for Residential appliances, in these cases a 3-way valve or mixing valve must be installed before the appliance to prevent water exceeding 140 °F (60 °C) from entering the appliance.
- ▶ When facing the heater, the ¾" cold connection is on the top right and the hot connection is on the top left.
- ▶ Tighten all water connections with the support of a wrench, see fig. 29.

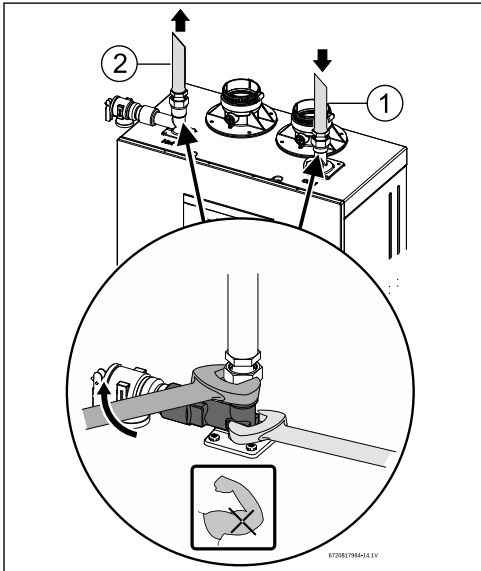

Fig. 28

- [1] Cold connection
- [2] Hot connection

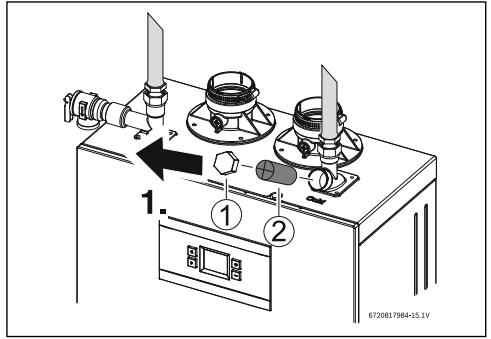

Fig. 29 Water filter

- [1] Cap
- [2] Water filter



CAUTION:

Appliance damage!

Appliance will overheat if not filled with water

- ▶ Ensure that the appliance is filled with water by opening a hot water tap, before plugging in the water heater to the power supply.

- ▶ The use of unions when connecting to the inlet and outlet connections is recommended. This will facilitate any necessary servicing.
- ▶ Plastic or PEX type plumbing materials are not suitable for connecting directly to or within 18" of the water heater.
- ▶ Although water piping throughout the building may not be copper, we require that copper or suitably rated stainless steel flex line be used for the water connections for 18" on either side of the water heater (follow local codes if more stringent).
- ▶ Never sweat any piping directly to water connections, as damage will occur.
- ▶ Keep water inlet and outlet pipes to no less than ¾" diameter to allow the full flow capacity.
- ▶ If the cold and hot connections to the heater are reversed, the heater will not function.
- ▶ Be certain there are no loose particles or dirt in the piping. Blow out or flush the lines before connecting to the water heater.
- ▶ Full port shutoff valves should be installed on both the cold water supply and hot water outlet lines to facilitate servicing the heater (see fig. 27).
- ▶ For installation on a private well system with a pressure tank, the lowest pressure range setting recommended is 30-45 psi (2.06 - 3.1 bar) to ensure optimal performance.

4.11 Domestic hot water recirculation with external pump

The following drawing is provided to outline one possible recirculation design. This schematic is for illustration only and must not be used for actual installation without appropriate engineering and technical advice from a properly licensed professional in the locality where the installation is made.

This appliance has been designed to permit recirculation by controlling an external pump. For this function a cable has been provided to electrically connect the external pump to the appliance. All the features of recirculation (→ section 6.5.4 **A1 Recirculation**) can be used. Please be aware that the cable does not provide 120 VAC to operate the recirculation pump, it is a dry-contact switching external voltage of up to a maximum of 5 amps.

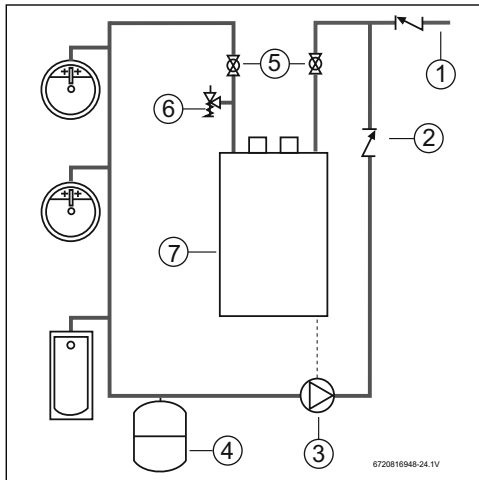

Fig. 30 Recirculation application

- [1] Cold water supply
- [2] Check valve
- [3] Circulator pump
- [4] Expansion tank
- [5] Shutoff valves, field supplied
- [6] PRV
- [7] RTG-K-160/199N/X1

4.12 Adjusting the recirculation settings

The pump and burner turn ON and OFF based on a delta between the set point temperature on the water heater and the inlet water temperature sensor value. This delta is called the **comfort level**.

The higher the comfort level, the smaller the delta between the set point temperature on the water heater and the inlet water temperature sensor value, resulting in a hotter recirculation system.

The smaller the comfort level, the larger the delta between the set point temperature on the water heater and the inlet water temperature sensor value, resulting in a cooler recirculation system.

Below is a graph illustrating how the comfort level value changes the recirculation system's temperature.

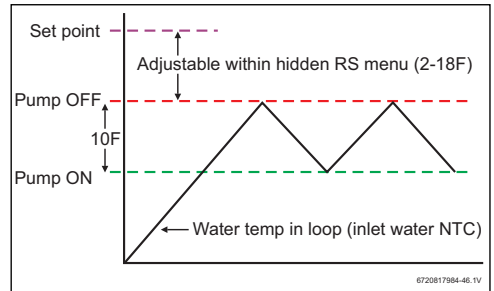

Fig. 31 Pump activation and deactivation thresholds

Comfort level	Delta T (°F)
1	18
2	16
3	14
4	12
5	10
6	8
7	6
8	4
9	2

Table 18 RS Menu

The **comfort level** can be adjusted to achieve the desired balance between readiness of hot water at the point of use and energy consumption.



A higher comfort level will result in longer pump run times, which will consume more electricity and gas.

4.13 Recirculation with the RTG-K-160/199N/X1

Recirculation with the RTG-K-160/199 models requires the installation of an external pump.

Installation instructions

The RTG-K-160/199 models have the capability of controlling an external pump by switching power ON and OFF to the external pump using the recirculation pump cable.



Use only bronze or stainless steel pumps. Do not use pumps of iron construction as they will oxidize and pose health risks.

Refer to pump manufacturers pressure vs flow specifications to select a pump that will provide adequate flow through the recirculation system.

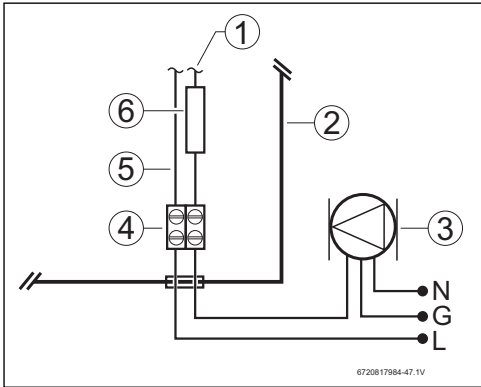

Fig. 32

- [1] Cable to control board
- [2] Appliance front cover
- [3] External recirculation pump (field supplied)
- [4] Terminal block
- [5] Recirculation pump cable
- [6] 5 amp fuse

The flow rate through the recirculation system must be larger than the activation flow rate of the water heater, 0.4 GPM.

A flow rate through the recirculation system greater than 1 GPM is recommended.

4.14 Space heating applications



CAUTION:

- ▶ If the set point temperature is above 120°F (49 °C), precautions should be taken to protect users of potable water from scalding.

NOTICE:

- ▶ The use of a flow switch is recommended to ensure DHW priority and to prevent "cold-blow" situations when the Bradford White tankless water heater is used with an air handler. Air handler installation must include a pump. The flow switch should be used to disable the blower on the air-handling system when domestic water is used.

NOTICE:

- ▶ Ensure the primary pump is properly sized to provide adequate flow for the system heat load.



For external pump sizing please refer to the pressure drop curves, fig. 34. Also remember to account for system piping pressure loss. A minimum of 1.7 GPM is recommended to provide adequate flow through the water heater when determining the size of the primary pump.

Bradford White tankless water heaters are approved for use in combination DHW and space heating applications (open-loop setup).

These water heaters are not approved for use in space heating only applications (closed-loop setup). Figure 33 gives an example of a combination DHW and space heating application that is allowable. Use of tankless water heater in a combination DHW and space heating application will result in the product warranty being reduced to 3 years.

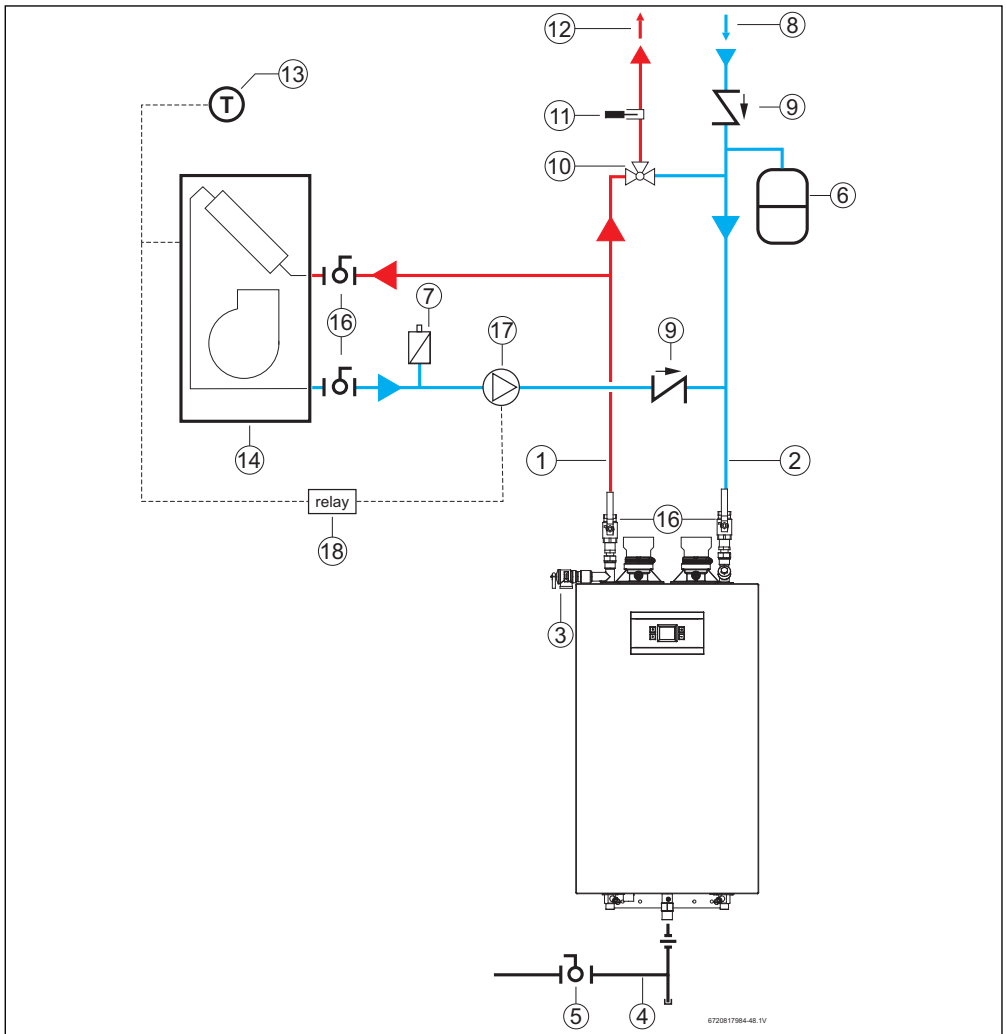

Fig. 33 Hydro air system with water heater

- | | |
|---|---|
| [1] Hot water outlet | [11] Thermometer (field supplied) |
| [2] Cold water inlet | [12] DHW outlet |
| [3] Pressure relief valve | [13] Thermostat (field supplied) |
| [4] Gas supply | [14] Air handler |
| [5] Shut off gas valve (field supplied) | [15] Check valve (field supplied) |
| [6] Thermal expansion tank (as required) | [16] Shutoff valve (field supplied) |
| [7] Air purge (field supplied) | [17] Circulation pump (only required if air handler doesn't include internal pump) (field supplied) |
| [8] Cold water supply | [18] Relay (only required if air handler doesn't include internal pump) (field supplied) |
| [9] Check valve (field supplied) | |
| [10] Thermostatic mixing valve (field supplied) | |

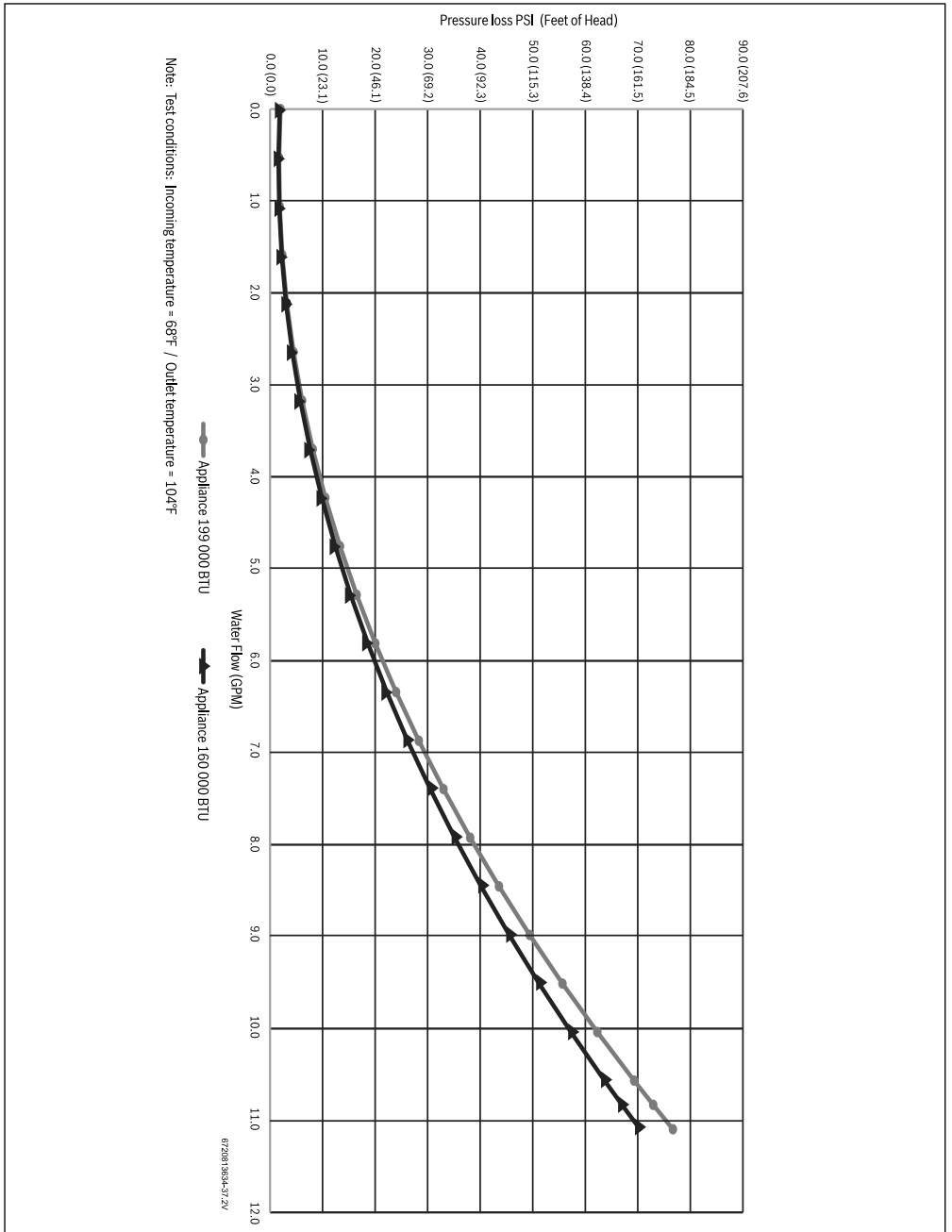

Fig. 34 Pressure drop curve

4.15 Measuring gas pressure

4.15.1 Gas supply pressure

Confirm gas pressure upon installation.

Connecting manometer

- ▶ Shut off gas supply at installer supplied shutoff valve for this water heater.
- ▶ Locate the inlet gas pressure test port (see Fig. 35).
- ▶ Loosen the screw inside test port fitting (do not remove) and connect the manometer tube to the test port (see Fig. 35).

Static Pressure Test

- ▶ Turn the gas supply back on.
- ▶ Record the static gas pressure reading in table 20.

Dynamic Pressure Test

- ▶ Turn ON the appliance.
- ▶ Access menu **P1 Max. Power**, see section 6.5.

Note: While in this mode the appliance will run constantly at maximum power and allow maximum water flow.

For inlet gas pressure adjustment consider the following table:

Gas type	NG	LPG
Inlet gas Pressure	3.5" WC ¹⁾	8" WC

- 1) To assure maximum heat input at maximum vent length, the minimum gas pressure should be 5" W.C. for the 199 kBtu models and 4" W.C. for the 160 kBtu models. For more information see section 4.6.3.

Table 19 Minimum inlet gas pressure under full operation

- ▶ Operate all other gas appliances (except heater) on the same gas piping system at maximum output.
- ▶ Open all hot water taps to achieve a flow rate of at least 6 gallons per minute. (1 tub and 2 sinks should be sufficient). If heater goes back to P2, open more hot water fixtures to allow sufficient flow to keep the water heater in P1.
- ▶ Record the lowest operating gas pressure reading in table 20.
- ▶ Turn OFF the appliance.
- ▶ Shut off gas supply.
- ▶ Disconnect the manometer tube from the test point.
- ▶ Tighten the screw inside test point fitting.

Depending on the vent length, gas pressures below 5" W.C. for Natural Gas or 8" W.C. for LPG may result in reduced power output or possible error codes and must be corrected. See Gas Connections, chapter 4.8, page 33.

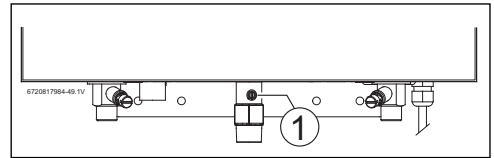

Fig. 35 Gas pressure test port

- [1] Gas pressure measuring port

	Gas pressure	Date
Static Gas Pressure Reading		
Dynamic Gas Pressure Reading		

Table 20 Inlet gas pressure readings

5 Electrical connections

5.1 Electrical power supply



DANGER:

Risk of electrocution!

- ▶ For safety reasons, disconnect the power supply cord to the water heater before any service or testing is performed.



DANGER:

- ▶ This water heater must be electrically grounded in accordance with the most recent edition of the National Electrical Code. NFPA 70. In Canada, all electrical wiring to the heater must be in accordance with local codes and the Canadian Electrical Code, CSA C22.1 Part 1. Do not rely on the gas or water piping to ground the metal parts of the heater.



WARNING:

- ▶ Modification of or tampering with the power supply cord is prohibited.
- ▶ Use of extension cords is prohibited.

The water heater requires an electrical power supply from a 120VAC / 60Hz properly rated receptacle and must be properly grounded.

The water heater is wired as shown in the wiring diagram (chapter 10, Fig. 62).

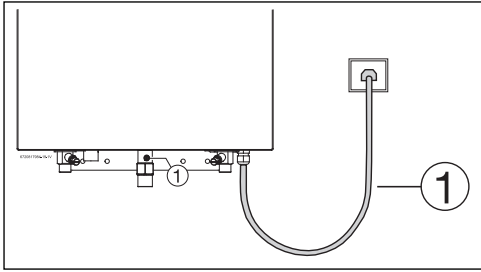

Fig. 36 Connecting power supply cord

[1] Power cord length: 5.9ft (1.8m).

Note: The power supply that the appliance is plugged into should be isolated from possible water damage. Observe proper clearance to avoid damages.

5.2 Position of the fuses in control unit

To check fuses, proceed as follows:

- ▶ Remove the front cover, see fig. 3, page 12.
- ▶ Disconnect all the cables from the control unit.
- ▶ Press the four snaps of the control unit and remove the cover.

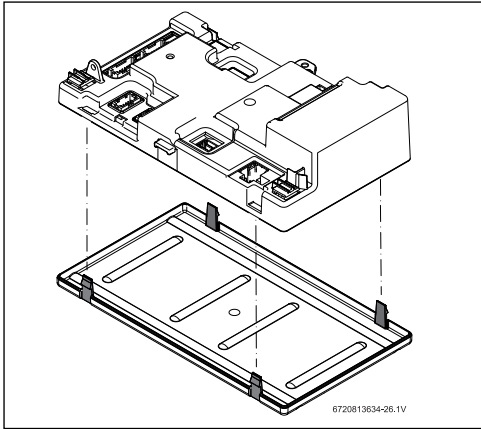

Fig. 37 Control Unit

- ▶ Press the four snaps inside the control unit and remove the PCB.

- ▶ Check the fuse on the printed circuit board for electrical continuity, see fig. 38, [1].

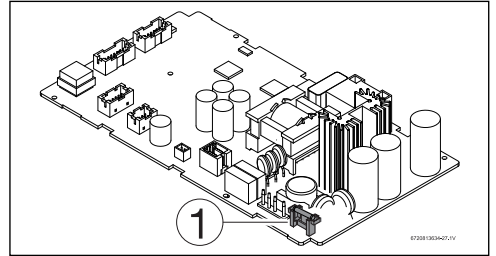

Fig. 38 Fuse position

[1] Fuse

- ▶ After checking the fuses, reinstall all parts in reverse order.

6 Operation instructions

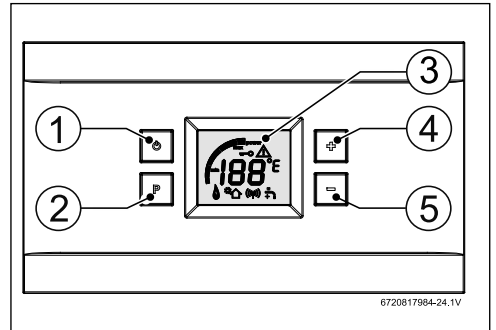

Fig. 39

- [1] On/Off button
- [2] Program Key
- [3] LCD display
- [4] Up button
- [5] Down button

NOTICE:

Instruction to clean display

- ▶ Wipe down with a damp cloth. Do not use any aggressive or corrosive cleaning agents to clean the window.

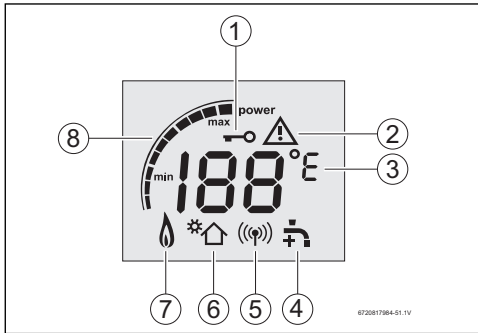

Fig. 40 Description LCD display

- [1] Locked condition indicator
- [2] Error indicator
- [3] Temperature indicator
- [4] Activation water flow
- [5] Cascading Master indicator
- [6] Solar mode indicator
- [7] Flame indicator
- [8] Power bar indicator

6.1 For your safety read before operating your water heater

! DANGER:

Explosion hazard!

- ▶ If you do not follow these instructions exactly, a fire or explosion may result causing property damage, personal injury or loss of life.

NOTICE:

Appliance malfunction!

Strong magnetic fields can interfere with the electronics, which can lead to appliance malfunction.

- ▶ Do not attach magnets to this water heater, neither install it near strong magnetic fields.

A. This appliance is equipped with electronic ignition for lighting the main burner. When turning the heater on, if you smell gas or detect a gas leak, follow these instructions exactly.

WHAT TO DO IF YOU SMELL GAS

! DANGER:

Risk of explosion!

- ▶ Turn off the gas shut-off valve.
- ▶ Open windows and doors.
- ▶ Do not try to ignite the appliance.
- ▶ Do not touch any electrical switch, telephone, and do not use outlets.
- ▶ Extinguish all open flames. Do not smoke! Do not use lighters!
- ▶ Warn all occupants of the building. Do not ring doorbells!
- ▶ If you can hear gas leaking, leave the building immediately.
- ▶ Prevent others from entering the building and notify the police and fire department from outside the building.
- ▶ From outside the building, call the gas utility company and a trained and certified installer.

B. Use only your hand to press the on/off control button. Never use tools. If the touch control display is dirty, wipe down with a damp cloth. Forceful repair may result in a fire or explosion.

C. Do not use this appliance if any part has been under water. Immediately call a qualified service technician to inspect the appliance and to replace any part of the control system and any gas control which has been under water.

6.2 Power

To turn ON the appliance;

- ▶ Press the  button.

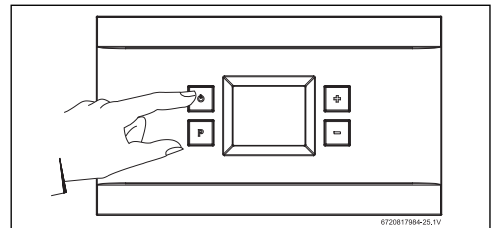

Fig. 41

To shut down the appliance;

- ▶ Press the  button.

6.3 Error code reset

Some possible faults can be solved by resetting the appliance.

To remove an error code from the display,

- ▶ Touch and hold  for more than 3sec.
The appliance will initiate the start up sequence.

NOTICE:

Appliance malfunction!

- ▶ If the problem persists, contact your installer.

6.4 Temperature selection



By default, the unit is set for 120 °F (49 °C) outlet water.

To select a hot water temperature:

- ▶ Press the buttons **+** and **-** until the desired temperature is displayed.

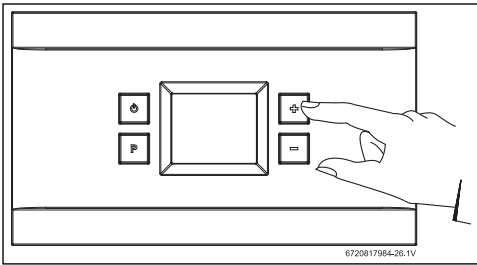

Fig. 42



To increase setpoint temperature limit of the appliance:

- ▶ Access the menu **LM - temperature Limit** (→ section 6.5.5).

A lower temperature set point will reduce the risk of scalding, reduce energy consumption and increase the longevity of the heat exchanger.

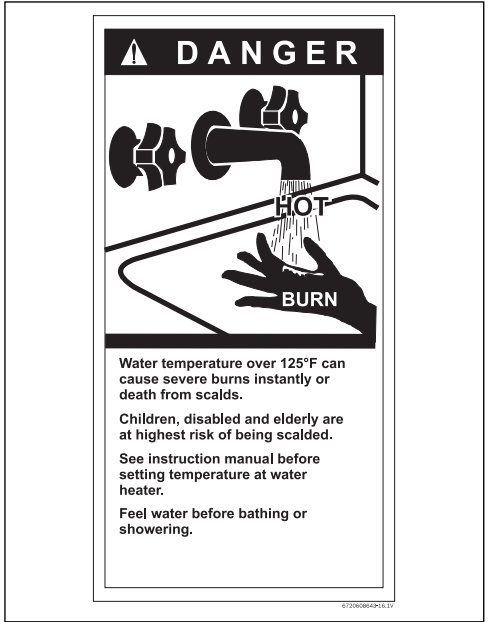

Fig. 43



DANGER:

The temperature shown on the display is approximate, always check with your hand before bathing children or elderly.

Setting the water temperature

The desired temperature of the hot water can be adjusted on the front control panel of the heater. The water heater has an electronically controlled gas valve that modulates the burner input in response to both varying hot water flow rates and/or changes in any incoming and outgoing water temperatures.

6.4.1 Programming the default setpoint temperature

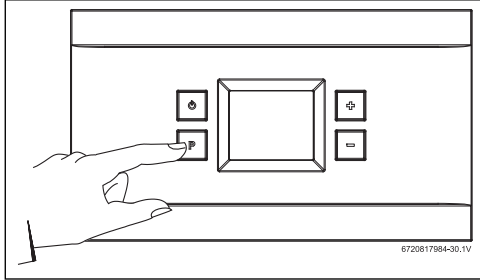

Fig. 44

- ▶ Press the buttons **+** and **-** to select the temperature to be memorized.
- ▶ Press the button **P** for 3 seconds to save the default set point temperature.

When the display stops blinking, the default set point temperature is saved in memory.

Selecting the default setpoint temperature

In order to select the default setpoint temperature.

- ▶ Press the programming button for 1 second.

Display shows the default setpoint temperature, which is now the hot water selected setpoint-temperature.

6.4.2 Solar Mode

If the appliance does not ignite, it means that the desired set temperature would be exceeded even running at minimum BTU. In this condition, the solar mode indicator will show on the display.

In most cases, solar mode is activated if the inlet water temperature exceeds the set point temperature minus 1 °F (0.5 °C).

Solar mode/warm inlet temperature activation formula

Temp. inlet > [Temp. set - 1 °F (0.5 °C)]

Ex.: 111 °F (43.9 °C) > [112 °F (44.4 °C) - 1 °F (0.5 °C)]

Table 21

6.5 Information /Adjustments menu

- ▶ Simultaneously press buttons **+** , **-** and **P** for 3 seconds.
Display shows **P4 (Information)**.

- ▶ Press buttons **+** or **-** to scroll through the available menus.

Available menus

Display	Description
P4	Information (section 6.5.1)
P7	Gas Type
P9	Purge (section 6.5.2)
PC	Cascading
SA	Settings (section 6.5.4)
LM	Temperature Limit (section 6.5.5)
PE	Appliance Type
PF	Bypass
PA	Actuator Calibration
IC	ICC
E	Exit
P0	Minimum Power
P1	Maximum Power
P2	Low Power
UC	Automatic Calibration
P3	Powerbus Address

Table 22

To return to main menu,

- ▶ Press buttons **+** or **-** until display shows **E**.
- ▶ Press button **P** to exit.
Display shows temperature setpoint.

6.5.1 P4 (Information)

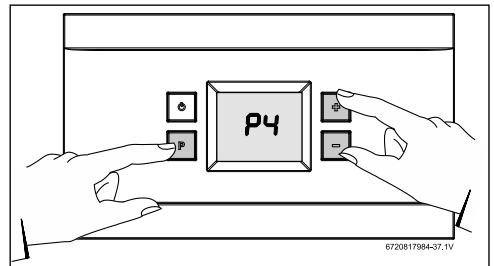

Fig. 45 P4 - Information

This menu provides access to several parameters.

- ▶ Access to information / adjustments manual.
Display shows **P4 (Information)**.
- ▶ Press the button **P** .
Display shows **E**.

Operation instructions

- ▶ Press buttons **+** or **-** to choose the following information.
 - **OD (Operation Data)**
 - **FH (Failure History)**
- ▶ Press the button **P** to select the desired information.

OD (Operation Data)

Allows you to view various parameters of the current operation of the appliance.

- ▶ Press buttons **+** or **-** to choose the following information:
 - **0d (Chamber NTC)** - current water temperature at heat exchanger outlet.
 - **1d (Inlet NTC)** - current temperature of the temperature sensor of the water inlet pipe.
 - **2d (Outlet NTC)** - current temperature of the temperature sensor of the water outlet pipe.
 - **3d (Flow)** - total flow through main and bypass valves.
 - **4d (barometric pressure)** - current barometric pressure at installation location.
 - **5d (Fan Speed)** - current fan speed.
 - **6d (Output Power)** - % current power.
 - **7d (SS Hex NTC)** - Flue gases temperature sensor at the condensing unit inlet (between heat exchangers).
 - **8d (Exhaust Gas NTC)** - Exhaust flue gases temperature sensor.
 - **9d (Ambient NTC)** - current temperature inside cabinet near the fan.
 - **10d (External Tank)** - current temperature on the external tank.
 - **11d (Operation Cycles)** - number of times burner has been started.
 - **12d (Operation Hours)** - number of hours burner has operated.
 - **E** - Exit.

How to select desired information:

- ▶ Press the button **P** to view the selected parameter. The information is showed on the display.
- ▶ Press the button **P** to return to parameters list.
- ▶ Press buttons **+** or **-** to select **E**.
- ▶ Press the button **P** to exit.

Numbers of cycles

To see how many cycles the appliance has done, please enter the menu **11d (Operation Cycles)**.

After checking the sub-modes **0C, 1C, 2C, 3C, 4C**, introduce the values in a table as the example below;

4C	3C	2C	1C	0C
00	04	06	17	76

Table 23 Total of cycles

In this example, the numbers of cycles is: 4 061 776.



In the calculation of number of cycles, **1 cycle** means **1 ignition**.

Numbers of hours

To see how many hours the appliance has worked, please enter the menu **12d (Operation Hours)**.

After checking the sub-modes **0H, 1H, 2H, 3H, 4H**, introduce the values in a table as the example below;

4H	3H	2H	1H	0H
00	00	00	18	63

Table 24 Total of hours

In this example, the numbers of hours is: 1 863.

FH (Failure History)

Allows you to view the last 10 error codes.

- ▶ Press buttons **+** or **-** to choose from **1F** (most recent failure) to **10F** (older failure).
- ▶ Press the button **P** to view the selected failure. The error code is shown on the display.
- ▶ Press the button **P** to return to failure list.
- ▶ Press buttons **+** or **-** to select **E**.
- ▶ Press the button **P** to exit.

6.5.2 P9 (Purge)

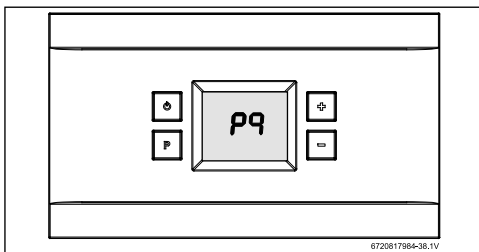



Fig. 46 P9 - Purge

This menu allows you to purge the exhaust circuit.

- ▶ Access to information / adjustments menu. Display shows **P4 (Information)**.

- ▶ Press the button  until the display shows **P9 (Purge)**. After 2 sec. the fan starts working to purge the exhaust circuit.



The fan remains running until the Purge menu is exited, to do so:

- ▶ Press the button .



6.5.3 PC (Cascading)





Use this menu only after installing the cascading kit (7736502750).

- ▶ Only a qualified technician can change this parameter.

How to choose an option in **PC** (Cascading),

- ▶ Press the button **P** to enter **PC** (Cascading).
- ▶ Press buttons  or  to scroll through the options.
 - **MA** (Master)
Appliance define as Master
 - **SL** (Slave)
Appliance define as Slave
 - **OF** (Off)
Turn off the cascading function

How to select an option,

- ▶ Press buttons  or  to choose an option.
- ▶ Press the button **P** until selected option blinks.
Option is activated.
- ▶ Press the button **P** to exit **PC** menu.

6.5.4 SA (Settings)

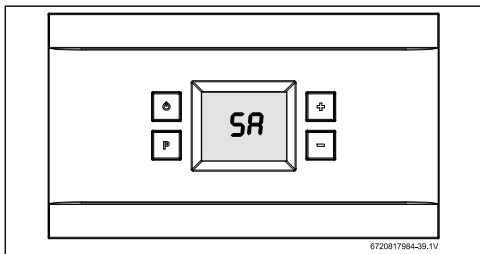





Fig. 47 SA - Settings

This menu provide access to several parameters.

- ▶ Access to information / adjustments menu.
Display shows **P4 (Information)**.



- ▶ Press the button  until the display shows **SA (Settings)**.
- ▶ Press the button **P** .
Display shows **E**.
- ▶ Press buttons  or  to choose the following information.

- **E Exit**
- **A1 Recirculation**
- **A8 Startup Delay**
- **A9 Units Set**
- **Ab Region Selection**
- **rS Recirculation settings**

- ▶ Press the button **P** to select the desired information.

A1 Recirculation

Choosing a recirculation program:

- ▶ Press the button **P** .
- ▶ Press buttons  or  to scroll through the options.
 - **OF OFF**
 - **Hr House Recirculation**
- Hot water readily available at faucets.
 - **tl Tank Loading Internal NTC**
- Tank loading using the water heater's inlet water temperature sensor to control the pump.
 - **tE Tank Loading External NTC**
- Tank loading using the external temperature sensor to control the pump.
 - **tA Tank Loading Aquastat**
- Tank loading using an external aquastat to control the pump.
- ▶ Press the button **P** to exit recirculation menu.

A8 (Startup Delay)

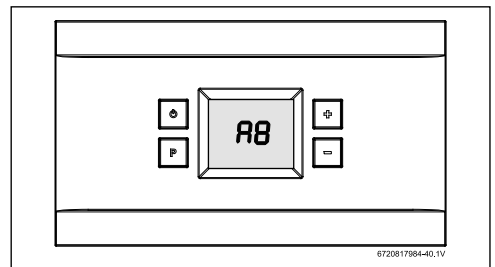



Fig. 48 A8- Startup Delay

This menu allows programing a burner start delay between 0 and 60 seconds, after detecting water flow.

- ▶ Access to information / adjustments menu.
Display shows **SA (Settings)**.
- ▶ Use the buttons  or  to choose **A8 (Startup Delay)**.

Operation instructions

- ▶ Press the button **P** .
Display shows **Startup Value(s)**.
- ▶ Press the buttons **+** or **-** to define, in seconds, the delay to start-up after detection of water flow.
- ▶ Press the button **P** for 3 seconds to save the desired value.
- ▶ Press the button **P** to exit **A8 (Startup Delay)** menu.

A9 (Units Set)

This menu allows you to choose the units visible on the display.

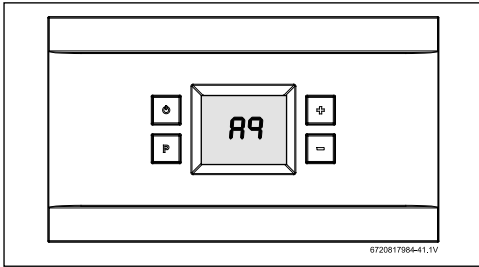

Fig. 49 A9 - Units

- ▶ Access to information / adjustments menu.
Display shows **SA (Settings)**.
- ▶ Press the button **-** until **A9 (Units)** is in the display.
- ▶ Press the button **P** .
- ▶ Press the buttons **+** or **-** to select measurement units,
 - **°C - Metric (l/min)**
 - **°F - Imperial (gal/min)**
- ▶ Press the button **P** for 3 secs. to save the selected units.
The selected unit blink.
- ▶ Press the button **P** to exit units menu.

AB (Region Selection)

- ▶ Press the button **P** .
Display shows following menu.
 - **EU (Europe)**
 - **nA (North America)**
- ▶ Press the button **P** for 3 secs. to save the selected region.
The selected region blinks.
- ▶ Press the button **P** to exit units menu.

RS Recirculation Settings

To define recirculation comfort level,

- ▶ Press the button **P** .

- ▶ Press buttons **+** or **-** to define comfort level.
 - **1**
 - **2**
 - ...
 - **9**

Choosing a higher comfort level (9) will set the recirculation water temperature closer to the set point defined on the water heater. Choosing a lower value (1) will favor efficiency at the expense of recirculation temperature comfort.

- ▶ Press the button **P** to select value and to exit Recirculation Settings.

6.5.5 LM (Temperature Limit)



140 °F (60 °C) is the maximum temperature to be defined for residential models.

How to select Temperature Limit,

- ▶ Press the button **P** .
Display shows temperature limit value.
- ▶ Press the buttons **+** or **-** to select desired temperature limit or **OF (OFF)** to unlock the Temperature Limit.
- ▶ Press the button **P** for 3 secs. to save your selection.
The selected temperature blinks.
- ▶ Press the button **P** to exit Temperature Limit menu.

6.5.6 PE (Appliance Type)



After defining these parameters, it isn't possible to modify.

This menu provides access to several parameters:

- ▶ Press the button **P** .
- ▶ Press buttons **+** or **-** to scroll through the options.
 - **TP (Appliance Type - Residential)**
 - **AP (Appliance Power - 199/160 kBTU)**
 - **MO (Appliance Model - IN/OU)¹⁾**
 - **E (Exit)**
- ▶ Press the button **P** for 3 secs. to save your selection.
- ▶ Press the button **P** to exit recirculation menu.

6.5.7 PF (Bypass Activation)

To Enable or Disable bypass function:

- ▶ Press the button **P** .
- ▶ Press buttons **+** or **-** to scroll through the options.

1) IN - Indoor / OU - Outdoor

- ▶ Press the button **P** .
Display shows following menu.
 - **EN** (Enable)
 - **DI** (Disable)
- ▶ Press the button **P** to select option.

6.6 Water valves calibration



Water valve calibration must be done when main water valve or bypass valve is replaced. Also required when electronic control unit is replaced.



The water valve calibration process takes several minutes.

- ▶ Do not interfere with the appliance.

6.6.1 MF (Main water Valve Auto Calibration)

- ▶ Open one hot water tap.
- ▶ Access menu **PA**.
- ▶ Press the button **P** .
- ▶ Press the buttons **+** or **-** to select **nF**.
- ▶ Press the button **P** .
The appliance will start the auto calibration of main valve.
Display will show water flow rate value X 10 (multiplied by 10) during the process.



Water flow will shut-off.

- ▶ Wait until indication of calibration completed appears on the screen, the value blinks.
- ▶ Wait until water flow blinks on the screen indicating that calibration is complete.

- ▶ Press the button **P** to return.

6.6.2 BP (Bypass Valve Auto Calibration)

- ▶ Open one hot water tap.
Flow rate between 0.80 GPM and 1.80 GPM is required.
It's possible to confirm this value by entering **BP bypass water valve** menu.
- ▶ Access menu **PA**.
- ▶ Press button **P** .
- ▶ Press button **+** or **-** to select **bP (bypass water valve)**.

- ▶ Press button **P** .
The appliance will start the auto calibration of the bypass valve.
Display will show water flow rate value X 10 (multiplied by 10) during the process.



The display shows the flow rate.

- ▶ You should adjust the flow rate at the beginning of the calibration process.
- ▶ Wait until water flow blinks on the screen indicating that calibration is complete.

- ▶ Press the button **P** to return to main menu.

6.7 Gas type



Improper gas type will affect appliance performance.

- ▶ Press simultaneously buttons **+** , **-** and **P** for 3 seconds.
Display shows **P4 (Information)**.
- ▶ Press buttons **+** or **-** to select **P7 (Gas Type)**.
- ▶ Press **P** to enter.
- ▶ Press buttons **+** or **-** to confirm gas type according to table 25.
- ▶ Press **P** for 3 seconds to confirm Gas type.
The selected gas type blinks.

Gas type	Display
Natural Gas	nA
Liquid Propane	LP

Table 25

6.7.1 Gas conversion from NG to LPG



DANGER:

Fatal accidents!

Before any service or testing in the appliance,

- ▶ Turn off the appliance.
- ▶ Disconnect the power supply cord.
- ▶ Shut off the gas supply.



WARNING:

The gas type conversion must only be carried out by a qualified contractor!

- ▶ Turn Off the appliance.
- ▶ Remove the front cover from the appliance (section 3.3.2).
- ▶ Remove the four screws that retain the cover plate to the gas manifold, see fig. 50 (plate in grey color).

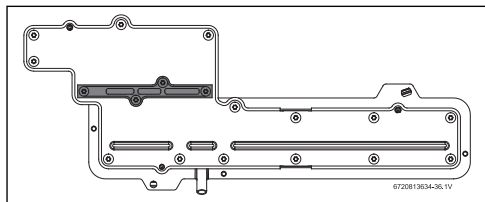

Fig. 50 Gas manifold

- ▶ Remove metal plate and seal.
- ▶ The 3 restrictor plates should be pre-assembled onto their tray, but if loose in box, follow installation instruction, as shown in fig. 51 [1].
- ▶ Insert the LP conversion plate in the appropriate location shown in Fig. 51 [2].

NOTICE:

- ▶ All three flow restrictors and seal must be assembled according to the Fig. 51 and Fig. 52, to ensure correct appliance performance.

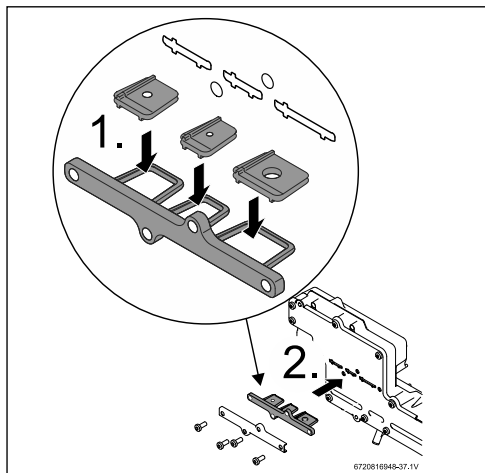

Fig. 51 199kBTU appliance gas conversion kit

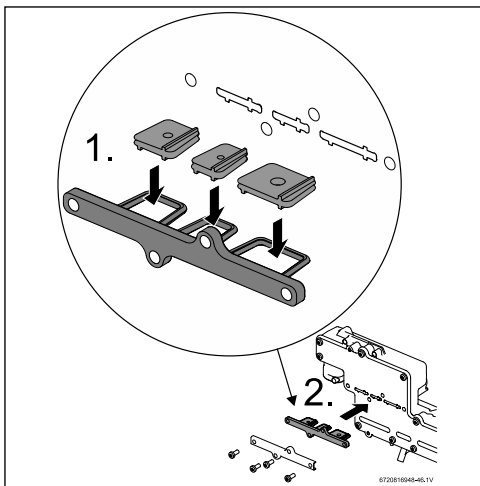

Fig. 52 160kBTU appliance gas conversion kit

- ▶ Tighten the four screws.
- ▶ Open the gas supply valve.
- ▶ Turn On the appliance.
- ▶ Open a hot water tap and check for gas leak (e.g. use leak detector fluid, like water and soap, over and around the metal plate) and act accordingly.
- ▶ Place the front cover.
- ▶ Access service mode by pressing and holding down at the same time, **P**, **+** and **-** for 3 seconds.
- ▶ Press buttons **+** or **-** until the display shows "P7".
- ▶ Press **P**.
- ▶ Press buttons **+** or **-** to choose **LP** (LPG).
- ▶ Press the button **P** for 3 secs. to save your selection. The selected temperature blinks.
- ▶ Update "TYPE OF GAS" in the rating plate of the appliance using the label provided with the gas conversion kit.
- ▶ Confirm CO₂ and CO values and, if necessary, adjust the parameters **P1** and **P2**, see chapter 8.12 for more information.

7 Maintenance and service



WARNING:

Maintenance must be done trained or qualified contractor.



DANGER:

- ▶ Always shut off the electrical power supply, shut off the manual gas valve and shut off the water valves whenever servicing.



WARNING:

- ▶ Replace all dismantled joints and o-rings with new ones.
- ▶ Consult spare part list at www.bradfordwhite.com.

NOTICE:

- ▶ Inspect and clean the complete water heating system once a year.
- ▶ Follow points 5 and 6 in Table 26 after 400 operation hours or 25000 cycles (whichever occurs first), see chapter 6.5.1 (Op. Data).
- ▶ Inspect the water heater and components for wear or fatigue. Immediately repair all faults to avoid damage to the system.

Annual maintenance table			Every year
1.	Inspect venting system		X
2.	Inspect combustion chamber		X
3.	Inspect burner		X ¹⁾
4.	Inspect pressure relief		X
5.	Inspect water filter		X
6.	Heat Exchanger	Descaling	X ²⁾
7.	Inspect condensate siphon		X
8.	Inspect air filter		X ¹⁾

- 1) Proceed with air filter cleaning or replacement if error code CE, CF and C2 is displayed. Check the flue exhaust for blockage (appliance is protected against flue blockage).
- 2) Proceed with heat exchanger descaling whenever error codes AA and E5 are displayed (appliance is protected against over heating in case of scaling, see table 17, Water Quality).

Table 26

7.1 Required annual maintenance

(To remove front cover, see page 12).

Venting System

- Venting system - inspect inside of flue pipe for any blockage or restriction.
- Observe burner flames during heater operation (front cover must be removed). Burner flames should be steady and blue. Yellow, inconsistent (bouncing) flames may be an indication of poor ventilation or combustion air supply. Inspect the combustion air inlet pipe for blockage or debris. Inspect combustion air and exhaust terminations for blockage or debris.

Heat Exchanger

- Inspect burner observation window (Fig. 66) for cracks or spillage of flue gases. Observe burner flames during heater operation. Flames should be steady and blue with no signs of yellowing. Yellow burner flames are an indication of improper combustion. Refer to Section 4.6, page 18 of this manual to verify exhaust system and combustion air supply meets manufacturer's specifications.

Pressure Relief

- Manually open the pressure relief valve to ensure proper operation.
- Make sure discharge drains away safely.

Inlet Water Filter

- Verify the inlet water filter screen is clean and undamaged. The inlet water filter is located on the top of the appliance, at the cold water inlet connection. (See Fig. 29, page 38). Close the installer supplied water shutoff valve, purge the water using discharge drains and remove the brass hex cap holding filter. Remove the filter, clean and/or replace if damaged.

Descaling

- In areas where the water supply has a high mineral content (see table 17, Water Quality), the heat exchanger should be flushed with a descaling solution. Scale build up will shorten the life of the water heater, and damage resulting from scale is not covered under warranty. Refer to section 7.3 for detailed instructions on descaling the heat exchanger.

Condensate siphon

- Check for debris and clean if needed.

Air Filter

- Verify if the air filter is clean and undamaged. The air filter is attached to the fan assembly, see fig. 53.
- Air filter must be cleaned or replaced in case it is clogged or damaged.

How to remove/assembly air filter,

- ▶ Disconnect the electrical supply from the water heater.
- ▶ Remove appliance front cover, see page 12.
- ▶ Loosen two philips head screws.
- ▶ Remove air filter from the fan.
- ▶ Proceed in the reverse order for assembly.

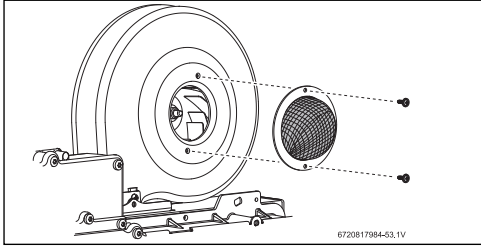

Fig. 53 Remove/assembly air filter

NOTICE:

Appliance malfunction!

- ▶ Air filter should not be removed during appliance normal operation as, it may increase the risk of burner blockage.

7.2 Winterizing for seasonal use

The water heater must not be installed in a location where it may be exposed to freezing temperatures unless connected to electrical power. All water must be drained from the heater in order to avoid damage to the unit from exposure to freezing temperatures.

NOTICE:

The use of agents such as anti-freeze is not permitted and voids the warranty, as they may cause damage to the water heater's internal components.

1. Press ON/OFF switch on the water heater to turn OFF the heater and unplug power supply cord. The display should be blank.
2. Shut off the gas supply to the water heater.
3. Shut off the water supply to the water heater using installer supplied shutoff valve.
4. Open hot water taps to drain and relieve pressure from the plumbing system. If water continues to flow after 5 minutes, a crossover of the hot and cold water pipes is present and must be corrected before proceeding.
5. Disconnect inlet and outlet water pipes from the water heater. Place a small bucket underneath the water heater to catch residual water remaining inside the water heater.

6. Using an air compressor, blow short bursts of air (100psi max) through the inlet water connection or inlet water filter until there is no water present coming through the outlet water connection of the heater.
7. Empty condensate trap.
8. Reconnect the water fittings, refill the condensate trap and return the heater to service when danger of freezing has passed.

7.3 Mineral scale build-up

Periodic descaling may be necessary in areas with high mineral content in the water, (see table 17, Water Quality). Scale buildup in the heat exchanger may result in lower flow rates, error codes of AA, E3 and E5 and boiling sounds in the heat exchanger.

A water softener is required if the water hardness exceeds 14 grains/gal (200 mg/l) calcium carbonate. Damage to the water heater resulting from hard water/scale deposits will not be covered under warranty.

Descaling using a pump

- ▶ Disconnect electrical supply from the water heater.
- ▶ Shut off the water supply to the water heater using (installer supplied) shutoff valve.
- ▶ Open hot water taps to drain and relieve pressure from the plumbing system.
- ▶ Drain water from the unit's heat exchanger by disconnecting inlet and outlet water connections from the heater.
- ▶ Connect a line (A) from the outlet of the circulating pump (installer supplied) to the inlet water fitting on the water heater (see fig. 54).
- ▶ Using another line (B), connect the water outlet fitting on the water heater. Route the other end of this line into a descaling reservoir.
- ▶ Using a 3rd line (C) from the descaling reservoir, connect to the inlet side of circulating pump. Install a filter on the end of the line in the descaling reservoir.
- ▶ Make sure all connections are "water tight."
- ▶ Fill tank with descaling solution so both lines inside are submersed. We recommend a straight white vinegar solution. If using a commercial descalant, refer to manufacturer's instructions for proper dilution ratio.
- ▶ Operate the circulating pump.
- ▶ Make sure there are no leaks and the solution is flowing from the descaling reservoir through the heater and returning to the reservoir.
- ▶ Run solution through the heater until the solution returning to the descaling reservoir comes out clear. (Changing to a fresh solution may be necessary during this process).

- ▶ Disconnect all lines and drain all solution from heat exchanger. Properly discard of solution.
- ▶ Close the inlet drain connection.
- ▶ Position a container below the hot water outlet and connect cold water supply. Open cold water supply shutoff valve and flush heat exchanger with clean water.
- ▶ Shut cold water shutoff valve and reconnect hot water supply to the water heater.
- ▶ Close outlet drain connection.
- ▶ Reconnect electrical supply to unit, open water shutoff valves, and return the unit to service.

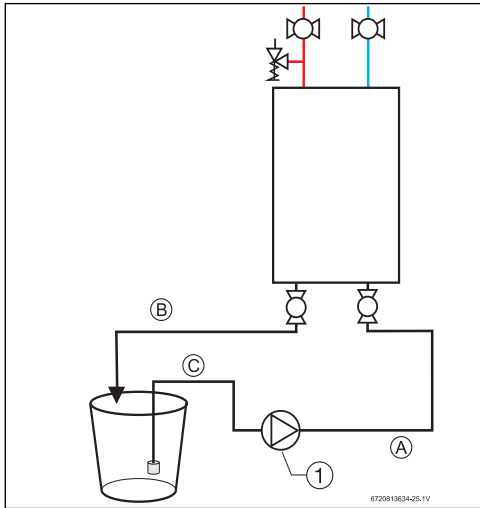

Fig. 54

[1] Pump

8 Troubleshooting



! DANGER:

If you are unable to perform the tasks listed below, or need additional assistance,

- ▶ Please contact a service provider or contractor.

NOTICE:

In some areas local code may require that the tasks described in this section must be performed by a certified contractor.

- ▶ Check your local codes to ensure compliance.

8.1 Introduction

Many of the questions customers ask regarding operation of this unit can be answered by following the troubleshooting steps as outlined below. For best results, perform each step before proceeding to the next. The suggested solutions may require that the cover be taken off. (See fig. 3, page 12).

8.2 Burner does not ignite when hot water is turned ON

It is recommended to use “P4 Information” page 47, chapter 6.5.1 as a tool for problem solving.

1. If the display is blank, verify power to outlet. (120VAC/ 60Hz properly grounded circuit required). Verify the heater power supply. Check all wire connections including plugged connectors.
2. With the power supply OFF and the power supply cord unplugged, remove the unit's front cover (See fig. 3, page 12). Check wire connections between the water valve, control unit and electrode set. See Fig. 62, page 68.
3. Verify the fuses in the control board are good. To access fuses, the control board must be removed. See section 5.2, page 44.
4. Make sure cold water inlet connection is plumbed to the right side of heater when facing unit. See Fig. 28, page 38.
5. A minimum of 0.45 gallons per minute (1.7 l/m) of hot water demand is required to activate the heater. Confirm at least 0.4 gpm flow by timing how long it takes to fill a container. A quart container should fill in 20 seconds or less, from hot water tap only. Gradually increase water flow (hot water demand) through the heater to determine if the heater activates with higher flow.
6. Clean inlet filter screen per chapter 4.10, page 37.
7. Inspect the water path for obstructions. Make sure all shower heads, faucet aerators and whole house filters are clear of debris.
8. Check for plumbing crossover. A crossover in the hot and cold plumbing pipes creates back pressure on the water flowing through the heater. Therefore, a higher flow rate than normal is needed to force the heater to activate. To check for a plumbing crossover, shut off the cold water supply to the hot water heater. Then open all of the hot water taps served by the heater. Wait 10 minutes and check for water flow at each tap. There should be no water flowing. Any continuous flow of water, small or large, indicates a crossover is present and must be corrected. Consult a professional plumber for help in correcting a crossover. Failing single lever faucet mixing valves are common causes of plumbing crossovers.

8.3 Water is too hot

1. Selected temperature on the unit is too high. To lower output temperature, see chapter 6.4, page 46.
2. Confirm the heater's gas type coincides with the type of gas being supplied. See fig. 2, page 12 for location of rating plate.
3. In areas where the water has a high mineral content, periodic descaling may be necessary. See chapter 7.3, page 54 for directions.

8.4 Water is not hot enough

1. Selected temperature on the unit is too low. To raise output temperature, see chapter 6.4, page 46.
2. Confirm the heater's gas type coincides with the type of gas being supplied. See fig. 2, page 12 for location of rating plate.
3. Check inlet gas particle screen for blockage at gas inlet connection on bottom of unit.
4. Verify gas pressure is in accordance with specifications in chapter 4.15, page 43. A gas pressure reading is needed to proceed further. Contact your original installer or a local certified gas technician to obtain this reading.
5. Cold water is mixing into the hot water lines (plumbing crossover). A plumbing crossover can unintentionally mix cold water with the hot water leaving the heater. The end result is a cooler water temperature than desired. To check for a plumbing crossover, shut off the cold water supply to the water heater. Then open all of the hot water taps served by the heater. Wait 10 minutes and check all taps for water flow. There should be no water flowing. Any continuous flow of water, small or large, indicates a crossover and must be corrected. Consult a professional plumber for help in correcting a crossover. Failing single lever faucet mixing valves are common causes of plumbing crossovers.

8.5 Low water flow/pressure

1. Too many hot water applications are being used simultaneously or too much flow is demanded. The water heater will effectively support two 2.0-2.5 GPM shower heads simultaneously or multiple sink applications. Greater draws will result in a water pressure drop and reduced flow at faucets.
2. If selected temperature on the unit is set too high for the demanded flow rate, the water heater will close its motorized water valve, reducing the hot water flow rate in an attempt to reach the selected output temperature. Lowering the selected temperature will allow the motorized water valve to open up for increased water flow rate.
3. Clean inlet filter screen per chapter 7.1, page 53 to increase flow through the heater.

4. Inspect the water path for obstructions. Make sure all shower heads, faucet aerators and whole house filters are clear of debris. It may be necessary to upgrade to higher flow rate shower heads if allowed by local code.
5. In areas where the water has a high mineral content, periodic descaling may necessary. See chapter 7.3, page 54 for directions.

8.6 Hot water temperature fluctuates at faucet

1. If the water heater set point temperature is high, mixing at the faucet could deactivate the water heater. The addition of too much cold will overpower hot water flow from the tankless water heater reducing its flow below the activation point.
If this slows the flow through the tankless water heater below its deactivation point, it will shut off the burner. The end result is nothing but cold water coming out of the outlet. Consult www.bradfordwhite.com for support.
2. Unbalanced pressure in water lines. Any restriction in the water heater, such as a clogged inlet filter screen, can result in unequal pressures between the cold and hot water lines. In such cases, when mixing in the higher pressure cold water at the tap, the lower pressure hot water can be overpowered. This will shut down the burners because the hot water flow rate fell below the minimum flow rate required for activation. Verify inlet filter screen is clean and clear of debris. See chapter 7.1, page 53 for inlet filter cleaning instructions.
3. The water heater deactivated by temperature balancing valves. If the outlet water temperature is set too high, the heater can produce temperatures that are too hot. A temperature balance shower valve will automatically mix in cold water to reduce the hot water temperature. In the event of any temperature instability at a fixture using a temperature balancing valve, refer to the valve manufacturer for instructions on internal adjustment setting. An adjustment should be made to minimize the amount of cold water the valve is adding. Additionally, the temperature setting on the heater can be lowered to reduce the amount of cold water that the temperature balance mixes in.
4. Inlet water pressure is erratic due to fluctuating supply water pressure. For installation on a private well system with the use of a pressure tank, the lowest pressure range setting recommended is 30 - 45 psi (2.06 - 3.1 bar). Consult your installer or local plumber for effective ways to maintain constant water pressure to the appliance when on a well system.

8.7 Noisy burner/heater during operation

Burner noises can be heard if combustion is not properly set. This could be caused by improper gas supply conditions (gas

pressure and/or gas composition).

Two types of noise can be heard: low pitch noise/vibration (rumbling) and high pitch noise/vibration (whistling).

8.7.1 High pitch noise

1. Verify if correct gas type is selected (see section 3.3).
2. Verify if gas pressure is within specified range (see section 3.2).
If gas type is properly selected, gas pressure is within range and the problem persists:
3. Perform the gas and air adjustment as described in section 8.11.

8.7.2 Low pitch noise

1. Verify if correct gas type is selected (see section 3.3).
2. Verify if gas pressure is within specified range (see section 3.2).
If gas type is properly selected, gas pressure is within range and the problem persists:
3. Perform the gas and air adjustment as described in section 8.11.

8.8 Error codes C1, C2, CF and/or CE

C1, C2, CF and CE errors could be caused by a too long flue and/or an obstruction in the venting.

1. Verify if there are any venting obstructions and remove them if that is the case.
2. Clean or replace the air filter, see chapter 7.1, page 53.
3. Ensure that the venting used is according to specifications (see section 4.6).
4. Reset the error by holding the On/Off button for 3s.
If there are no obstructions, and the problem persists:
5. Perform the gas and air adjustment as described in section 8.11.
6. If it is not possible to solve the problem with these measures and error persists, the burner surface (ceramat) might be obstructed (e.g. clogging due to dust/particles in the air). Contact Bradford White support line for further assistance into the diagnosis if your installation fits this description; in case of confirmation, replace the burner and revise installation conditions (→ section 4.3) to avoid recurrence.

8.9 Error codes EA and/or EC

EA and EC errors can appear if combustion is not properly set. This could be caused by improper gas supply conditions (gas pressure and/or gas composition).

1. Verify if correct gas type is selected (see section 6.7.1).

2. Verify if gas pressure is within specified range (see section 3.2).
If gas type is properly selected, gas pressure is within range and the problem persists:
3. Perform the gas and air adjustment as described in section 8.11.

8.10 Manifold gas pressure



DANGER:

Fatal accidents!

When the appliance is operating with the front cover removed:

- ▶ Do not stand in front of the appliance.
- ▶ Avoid breathing the combustion flue gases.
- ▶ Turn off the appliance and install the front cover assembly when adjustments and measurement are complete.

The manifold gas pressure measurement is only carried out if it is necessary to confirm the value from the rating plate. In case of a high deviation between measured and stated values, please proceed with Gas/air adjustment (see section 8.11)¹⁾.

- ▶ Turn Off the appliance.

- 1) Manifold gas pressure from the rating plate is valid for sea level operation with standard gas pressure and composition. If operating conditions are different from those, values from section 8.11 should prevail over manifold gas pressure to assure a correct appliance tuning.

- ▶ Remove the front cover of the appliance (see page 12). Do not disconnect the wire from HMI (display).

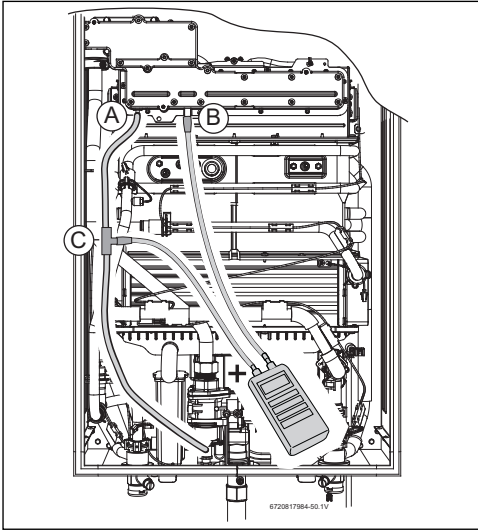

Fig. 55 Pressure head points

- [1] Air pressure head in the box
 - [2] Gas pressure head in the burner
 - [3] Tee (installer supplied)
- ▶ Loosen the set screw of the pressure head point [B].
 - ▶ Connect the pressure gauge connection "+" to the test point [B].
 - ▶ Loosen the set screw of the pressure head point [A].
 - ▶ Connect the pressure gauge "-" to the pressure head point [A].
 - ▶ Turn On the appliance.
 - ▶ Position the front cover near the appliance so the display cable can be connected to the appliance.
 - ▶ Place the front cover with the HMI near the appliance.
 - ▶ Open all hot water taps to achieve a flow rate of at least 6 gallons per minute. (1 tub and 2 sinks should be sufficient). If heater goes back to P2, open more hot water fixtures to allow sufficient flow and access to **P1 menu**.
 - ▶ Record the manifold gas pressure reading in table 27. Manifold gas pressure refers to the relative pressure between gas manifold nozzles inlet and outlet [A]-[B].

	Value	Date
Manifold gas pressure		

Table 27

- ▶ Turn Off the appliance.
- ▶ Disconnect the pressure gauges from the pressure head points [A] and [B].
- ▶ Tighten the shutter screws of the pressure head points [A] and [B].
- ▶ Reassemble the front cover onto the appliance.
- ▶ Turn ON the appliance to return to normal operation.

8.11 Adjusting Gas/Air flow

! DANGER:

Risk of CO poisoning!

Gas air/flow adjustment is performed with the front cover of the appliance removed. Avoid exposure to exhaust vent gases. Do not stand in front of the exhaust vent while appliance is operating.

i

Appliance is pre-adjusted by default with factory parameters.

Gas/Air adjustments are only required when:

- The appliance is converted to LPG and energy content is more than 2820 BTU/cu ft(→ section 6.7.1).
- After installation, the appliance shows repeated unresolved errors (→ chapter 9).
- In Natural Gas installations where energy content is less than 900 BTU/cu ft.
- After replacement of electronic control unit, fan or gas valve.

i

Improper gas pressure will affect combustion.

- ▶ Please see chapter 4.15 for more information.

8.11.1 Automatic adjust of Gas/Air flow

- ▶ Press and hold simultaneously buttons **P**, **+** and **-** for 3 seconds.
- ▶ Press the buttons **+** or **-** to select **UC (Combustion Automatic Adjustment)** menu.
- ▶ Press the button **P** to enter **UC** menu. Automatic adjustment will begin.

- ▶ Open hot water taps when the display shows **Tap Symbol** image (1 tub and 2 sinks should be sufficient; when there is enough water flow the image disappears).

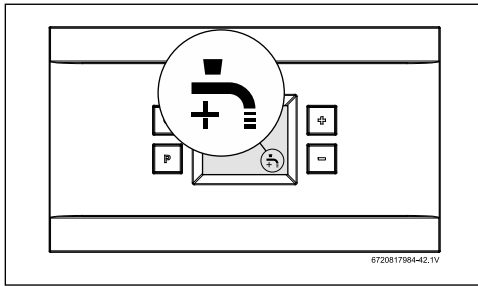

Fig. 56 Combustion Auto Adjust - Open Taps



The Combustion Auto Adjust process takes several minutes. Steps from 1 to 7 will appear on the display.

- ▶ Do not interfere with the appliance during the auto adjustment process.
- ▶ Wait until display shows **CA** blinking as a sign of calibration complete.
- ▶ Touch the symbol **P** to exit **UC** menu.

Gas and Air auto adjustment is complete.







In case of failure in the auto calibration process the error sign  appears. Verify if:

- ▶ Any error codes appear on the display. See table 30.
- ▶ Gas type and pressure are correct.
- ▶ Wind conditions are stable (e.g. wind gusts may be a cause of failure).
- ▶ Hot water flow is sufficient and stable (e.g. water from a well is a potential source of water instability).
In case of positive results for all these actions:
- ▶ Exit **UC** menu and repeat the process.
If failure persists:
- ▶ Perform manual adjustment according to chapter 8.11.2 or contact Bradford White support line for further assistance.

8.11.2 Manual adjust Gas/Air flow

Gas/Air flow adjustment is also possible to perform manually (only recommended if automatic adjustment can not conclude successfully).

First step - Adjust the maximum power (P1)

- ▶ Press the button  to turn ON.
- ▶ Press and hold simultaneously buttons ,  and  for 3 seconds, until display reads **P4**.

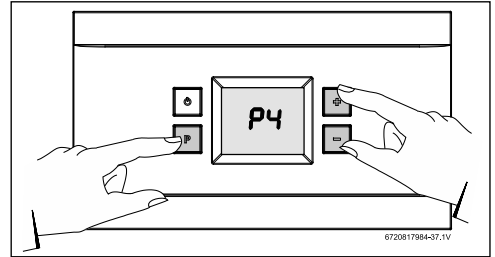





Fig. 57

- ▶ Press the buttons  or  to select **P1 (Maximum Power)** menu.
- ▶ Open hot water faucets when the display shows **Tap Symbol** image (1 tub and 2 sinks should be sufficient; when there is enough water flow the image disappears).
- ▶ Press **P** to enter **P1** adjustment. Display shows **E**.
- ▶ Press  or  until **L1** appears.
- ▶ Press the button **P** to enter **L1**. Display shows **L1** value.
- ▶ Verify if power bar level is at middle point, see fig. 58.

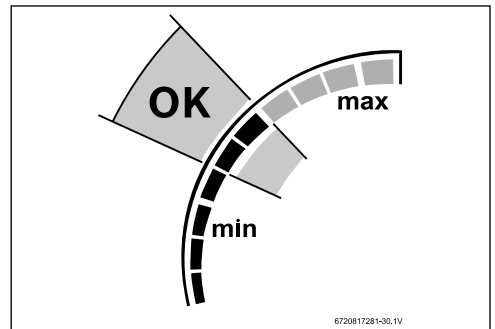

Fig. 58 Power bar middle point

- ▶ Press the buttons **+** or **-** to adjust parameter value if power bar level is out of range.¹⁾

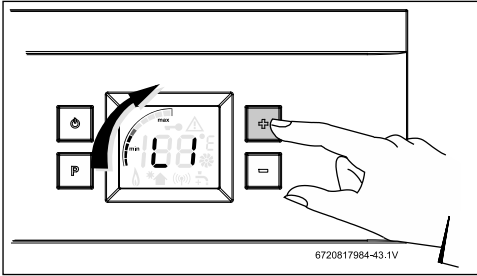

Fig. 59 Gas adjust - L1 parameter

- ▶ Press the button **P** for 3 seconds and appliance assumes value.
The value blinks as a sign of confirmation.
- ▶ Press **P** button to finish the L1 gas adjust.
- ▶ Press the button **+** or **-** until the display shows "A1".
- ▶ Press the button **P** to enter A1.
Display shows A1 value.
- ▶ Verify if power bar level is at middle point, see fig. 58.
- ▶ Press the buttons **+** or **-** to adjust parameter value if power bar level is out of range.²⁾

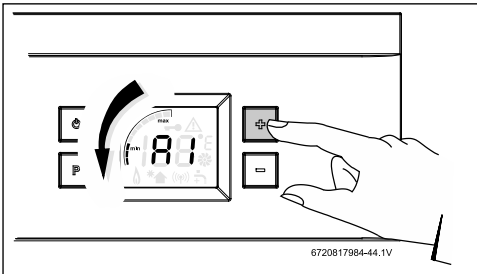

Fig. 60 Air adjust - A1 parameter

- ▶ Press the button **P** for 3 seconds and appliance assumes value.
The value flashes as a sign of confirmation.
- ▶ Press the button **P** to finish the A1 air adjust.
- ▶ Press the button **+** or **-** until the display shows "b1".

1) Increasing L1 value will cause an increase in power bar level and vice-versa.
2) Increasing A1 value will cause a decrease in power bar level and vice-versa.



If **b1** is blinking on the display,

- ▶ Wait until it stops.
- ▶ Press the button **P** to enter b1.
Display shows the parameter value blinking during calibration.
- ▶ Wait until display shows **CA** blinking as a sign of calibration complete.
- ▶ Press **P** button to finish the b1 automatic air adjust.
- ▶ Press the button **+** or **-** until the display shows **E**.
- ▶ Press the button **P** .
Display shows **P1**.

Second step - Adjust the Low power (P2)



Keep hot water taps opened to adjust **Low power (P2)**. The unit will ramp down to low fire and the water flow should decrease automatically.

- ▶ Press the buttons **+** or **-** to select **P2 (Low Power)** menu.
- ▶ Press **P** to enter **P2** adjustment.
Display shows **E**.
- ▶ Press **+** or **-** until **L2** appears.
- ▶ Press the button **P** to enter **L2**.
Display shows **L2** value.
- ▶ Verify if power bar level is at middle point, see fig. 58.
- ▶ Press the buttons **+** or **-** to adjust parameter value if power bar level is out of range.³⁾
- ▶ Press the button **P** for 3 seconds and appliance assumes value.
The value flashes as a sign of confirmation.
- ▶ Press **P** button to finish the L2 gas adjust (U1).

Parameter D2



- ▶ Only a qualified technician can change this parameter.

Gas and Air adjustment is complete.

3) Increasing L2 value will cause an increase in power bar level and vice-versa.

8.11.3 Factory default settings

Restore factory values for P1 Max. Power



To restore factory values for combustion settings.

- ▶ Proceed with the following steps.
-
- ▶ Access to menu **P1**Max. Power.
 - ▶ Press symbols **+** or **-** to select **rP (Reset Parameters)**.
 - ▶ Press the symbol **P** to select **rE**.
 - ▶ Press **P** for 3 seconds.
 - ▶ Press the symbol **P**.
 - ▶ Press the symbol **P**.
The display blinks to confirm change.
 - ▶ Press the symbol **P**.
The factory default values for **P1** are restored.

Restore factory values for P2 Low Power

- ▶ Access to menu **P2**.
- ▶ Press symbols **+** or **-** to select **rP (Reset Parameters)**.
- ▶ Press the symbol **P** to select **rE**.
- ▶ Press the symbol **P** for 3 seconds.
- ▶ Press the symbol **P**.
The display blinks to confirm change.
- ▶ Press the symbol **P**.
The factory default values for **P2** are restored.

8.12 CO emission check

In case air/gas combustion adjustment has been performed check emissions using reference values in tables 28 and 29.

8.12.1 Access to CO₂ measuring port



WARNING:

Only a qualified technician can perform these steps.

This can cause carbon monoxide poisoning.

- ▶ Follow the instructions carefully.



Allow the appliance to stabilize before performing CO/CO₂ readings.

Let appliance warm up and wait for 2 or 5 minutes for each CO/CO₂ readings.

This will avoid wrong CO/CO₂ reading.

- ▶ Open a hot water tap and let the appliance work for 2 or 5 minutes.
- ▶ Remove the screw from the flue adaptor on the left side of the appliance, as seen in fig. 61.
- ▶ Insert CO₂ analyzer probe into the measuring port. The tip of the probe should be in the center of the flue pipe (approx 1.5" inserted). Avoid air gaps between probe and measuring port as they can alter readings.

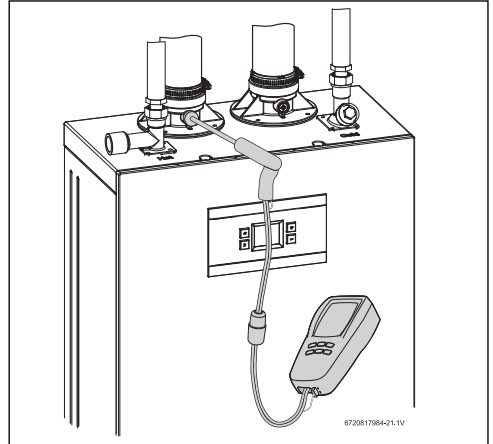

Fig. 61 CO₂ measuring port

8.12.2 CO₂ and CO values

		RTG-K-199N/X1	
		CO ₂ range (%)	Max. CO level (measured)
Nat. Gas			
max. input	P1	8.4 % - 9.0 %	< 250 ppm
min. input	P2	N/A	< 100 ppm
LP Gas			
max. input	P1	9.7 % - 10.4 %	< 250 ppm
min. input	P2	N/A	< 100 ppm

*** Values above are for climate controlled conditions. Inputs such as gas pressure, heating value of the gas, humidity and temperature of combustion air all impact CO and CO₂ values. Changes in these inputs can result in different CO and CO₂ values on the same appliance.**

Table 28 CO & CO₂ target numbers

		RTG-K-160N/X1	
		CO ₂ range (%)	Max. CO level (measured)
Nat. Gas			
max. input	P1	8.5 % - 9.1 %	< 250 ppm
min. input	P2	N/A	< 100 ppm
LP Gas			
max. input	P1	10.0 % - 10.6 %	< 250 ppm
min. input	P2	N/A	< 100 ppm
<p>* Values above are for climate controlled conditions. Inputs such as gas pressure, heating value of the gas, humidity and temperature of combustion air all impact CO and CO₂ values. Changes in these inputs can result in different CO and CO₂ values on the same appliance.</p>			

Table 29 CO & CO target numbers

8.12.3 Returning to Service

- ▶ Disconnect the pressure gauges from the pressure heads points [A] and [B].
- ▶ Tighten the shutter screws of the pressure heads points [A] and [B].
- ▶ Place front cover in the appliance.
- ▶ Remove CO₂ analyzer probe and reinstall screw in flue accessory.
- ▶ Turn OFF the appliance and then turn ON the appliance. The appliance is ready for normal operation.

9 Problem solving

9.1 Error code diagnostics



To remove error code from the display, press and hold on/off button for 3 seconds.



Fitting, maintenance and repair must only be carried out by qualified contractors. The following table describes the solutions for possible problems (solutions followed by footnote ¹ must only be carried out by qualified contractors).

Display	Description	Solution
A0	Water temperature sensor [17] [19] [20] disconnected or damaged.	<ul style="list-style-type: none"> ▶ Check sensor wire connections.^{1) 2)} ▶ Replace the sensor and/or wire connections, if the problem persists.¹⁾
A1	Air temperature inside the cabinet [18] is above 158 °F (70 °C). Appliance regulates power to protect against overheat.	<ul style="list-style-type: none"> ▶ External air temperature is above 140 °F (60 °C). ▶ Check for flue leakages inside the appliance ¹⁾
A2	External water temperature sensor/aquastat [21] disconnected, damaged or not properly installed.	<ul style="list-style-type: none"> ▶ Check temperature sensor and associated connections.^{1) 2)} ▶ Check sensor position in the tank well. ▶ Verify if correct recirculation settings are selected (→ section 6.5.4). ▶ Replace the sensor and/or wire connections, if the problem persists.¹⁾
A3	Flue gases temperature sensor [15] disconnected or damaged.	<ul style="list-style-type: none"> ▶ Check sensor wire connections.^{1) 2)} ▶ Replace the sensor and/or wire connections, if the problem persists.¹⁾
A4	Air temperature sensor [18] disconnected or damaged.	<ul style="list-style-type: none"> ▶ Check sensor wire connections.^{1) 2)} ▶ Replace the sensor and/or wire connections, if the problem persists.¹⁾
A5	Condensing unit flue temperature sensor [16] disconnected or damaged.	<ul style="list-style-type: none"> ▶ Check sensor wire connections.^{1) 2)} ▶ Replace the sensor and/or wire connections, if the problem persists.¹⁾
A6	Inlet cold water temperature sensor [20] disconnected or damaged.	<ul style="list-style-type: none"> ▶ Check sensor wire connections.^{1) 2)} ▶ Replace the sensor and/or wire connections, if the problem persists.¹⁾
A7	Heat exchanger hot water temperature sensor [16] disconnected or damaged.	<ul style="list-style-type: none"> ▶ Check sensor wire connections.^{1) 2)} ▶ Replace the sensor and/or wire connections, if the problem persists.¹⁾
A8	Outlet hot water temperature sensor [17] disconnected or damaged.	<ul style="list-style-type: none"> ▶ Check sensor wire connections.^{1) 2)} ▶ Replace the sensor and/or wire connections, if the problem persists.¹⁾
A9 ³⁾	Incorrect output power (too low).	<ul style="list-style-type: none"> ▶ Check gas inlet pressure (→ section 4.15).¹⁾ ▶ Check water temperature sensors [17][19][20] and water flow sensor [14] wire connections. ▶ Check connections or replace sensor (→ section 11), replace any if it is not according to specification.¹⁾²⁾

Display	Description	Solution
AA ³⁾	Condensing unit flue gases temperature [16] above 392 °F (200 °C) and/or flue gases temperature [15] above 145 °F (63 °C) at the exhaust sensor [15]. Appliance regulates power to protect against overheating.	<ul style="list-style-type: none"> ▶ Check flue gas temperature sensor. ▶ Check water inlet temperature sensor. ▶ Descale appliance (section 7.3).¹⁾
BB	Fan calibration triggered due to missed ignitions.	<ul style="list-style-type: none"> ▶ Check gas inlet pressure (→ section 4.15).¹⁾ ▶ Perform gas and air tuning (→ section 8.11).¹⁾
BC	Successive fan calibration with similar learned values.	<ul style="list-style-type: none"> ▶ Check gas inlet pressure (→ section 4.15).¹⁾ ▶ Perform gas and air tuning (→ section 8.11).¹⁾
C1 ⁴⁾ C2 ⁴⁾	Flue blockage detected during startup due to insufficient combustion air.	<ul style="list-style-type: none"> ▶ Reset error (press and hold on/off button for 3 seconds). If the problem persists: ▶ Check air intake and exhaust pipes and terminals for obstructions and reset the error. ▶ Check if the air filter is dirty or clogged, clean or replace it if needed. ▶ Check if flue length is according to specification (→section 4.6) and reset the error. ▶ Perform gas and air tuning (→ section 8.11).¹⁾
C3	Flow sensor [14] does not detect water recirculation.	<ul style="list-style-type: none"> ▶ Check pump and connections.¹⁾ ▶ Check recirculation circuit for any blockage.
C5	Bypass water valve [8] disconnected or damaged.	<ul style="list-style-type: none"> ▶ Check bypass water valve wire connections.¹⁾ If the problem persists: ▶ Replace the bypass water valve and/or wire connections. After valve replacement, proceed with bypass water valve calibration (→section 6.6).¹⁾
C7	Fan [2] disconnected or damaged.	<ul style="list-style-type: none"> ▶ Check fan wire connections. ▶ Reset error (press and hold on/off button for 3 seconds) If the problem persists: ▶ Replace the fan and/or wire connections.¹⁾
C8	Main water valve [22] disconnected or damaged.	<ul style="list-style-type: none"> ▶ Check main water valve wire connections.¹⁾ If the problem persists: ▶ Replace main water valve and/or wire connections. After valve replacement, proceed with main water valve calibration (→section 6.6).¹⁾
C9	Barometric pressure sensor fault.	<ul style="list-style-type: none"> ▶ Reset error (press and hold on/off button for 3 seconds). If the problem persists: ▶ Replace electronic control unit (ECU).¹⁾
CA	Water flow above 9.2gpm.	<ul style="list-style-type: none"> ▶ Disconnect the appliance and purge hydraulic circuit to remove air.¹⁾ ▶ Install water flow restrictor.¹⁾ ▶ Check water pressure does not exceed 150psi (→section 3.2).

Display	Description	Solution
CE ⁴⁾	Flue blockage detected during operation due to excessive pressure on the siphon.	<ul style="list-style-type: none"> ▶ Reset error (press and hold on/off button for 3 seconds). If the problem persists: ▶ Check exhaust pipes and terminals for obstructions and reset the error. ▶ Check if the air filter is dirty or clogged, clean or replace it if needed. ▶ Check if flue length is according to specification (→section 4.6) and reset the error. ▶ Perform gas and air tuning (→ section 8.11). ¹⁾
CF ⁴⁾	Flue blockage detected during operation due to insufficient combustion air.	<ul style="list-style-type: none"> ▶ Reset error (press and hold on/off button for 3 seconds). If the problem persists: ▶ Check air intake and exhaust pipes and terminals for obstructions and reset the error. ▶ Check if the air filter is dirty or clogged, clean or replace it if needed. ▶ Check if flue length is according to specification (→section 4.6) and reset the error. ▶ Perform gas and air tuning (→ section 8.11). ¹⁾ ▶ Contact Bradford White support line for additional information and assistance in case of installation in dusty areas.
EO	Electronic control unit internal error.	<ul style="list-style-type: none"> ▶ Reset error (press and hold on/off button for 3 seconds). If the problem persists: ▶ Replace electronic control unit.¹⁾
E1	Hot water temperature above 194 °F (90 °C). Appliance burner cut off to prevent scalding and reactivation after cooling down.	<ul style="list-style-type: none"> ▶ Disconnect the appliance and purge hydraulic circuit to remove air. If the problem persists: ▶ Reduce setpoint temperature to minimize temperature instabilities.
E3 ⁴⁾	Flue gas temperature above 167 °F (75 °C) or 2 minutes above 145 °F (63 °C). Appliance burner cut off to prevent overheating.	<ul style="list-style-type: none"> ▶ Descale appliance (→ section 7.3).¹⁾ ▶ Reset error (press and hold on/off button for 3 seconds). If the problem persists: ▶ Check sensor resistance [15] (→section 11) and replace the sensor if it is not according to specification.¹⁾²⁾
E4	Air temperature inside cabinet above 176 °F (80 °C) or 2 minutes above 158 °F (70 °C). Appliance burner cut off to prevent overheating.	<ul style="list-style-type: none"> ▶ Check for flue gas leakage inside the cabinet or concentric vent.¹⁾ ▶ Reset error (press and hold on/off button for 3 seconds). If the problem persists: ▶ Check sensor resistance [18] (→section 11) and replace the sensor if it is not according to specification. ^{1) 2)}

Display	Description	Solution
E5	Condensing unit flue gas temperature above 428 °F (220 °C) or 2 minutes above 392 °F (200 °C). Appliance burner cut off to prevent overheating.	<ul style="list-style-type: none"> ▶ Descale appliance (→ section 7.3).¹⁾ ▶ Reset error (press and hold on/off button for 3 seconds). If the problem persists: ▶ Check sensor resistance [16] (→section 11) and replace the sensor if it is not according to specification.^{1) 2)}
E7	Electronic control unit internal error.	<ul style="list-style-type: none"> ▶ Reset error (press and hold on/off button for 3 seconds). If the problem persists: ▶ Replace electronic control unit.¹⁾
E8	Error during ionization test. Electronic control unit internal error.	<ul style="list-style-type: none"> ▶ Replace electronic control unit.¹⁾
E9	Thermal fuse [13] broken.	<ul style="list-style-type: none"> ▶ Replace thermal fuse.¹⁾
EA ⁴⁾	Ignition failure.	<ul style="list-style-type: none"> ▶ Check gas inlet pressure (→ section 4.15).¹⁾ ▶ Perform gas and air tuning (→ section 8.11).¹⁾
EB	Electronic control unit internal error.	<ul style="list-style-type: none"> ▶ Reset error (press and hold on/off button for 3 seconds). If the problem persists: ▶ Replace electronic control unit.¹⁾
EC ⁴⁾	Flame lost during operation.	<ul style="list-style-type: none"> ▶ Check gas inlet pressure (→ section 4.15).¹⁾ ▶ Perform gas and air tuning (→ section 8.11).¹⁾
EE	Gas valve modulation solenoid [7] disconnected.	<ul style="list-style-type: none"> ▶ Check gas valve wire connection.¹⁾ If the problem persists: ▶ Replace the gas valve and/or wire connections and/or electronic control unit. For gas valve replacement perform gas and air tuning (→ section 8.11).¹⁾
EF	Wrong gas connected (LP instead of NG) for current appliance configuration.	<ul style="list-style-type: none"> ▶ Check gas type (→ section 6.7).¹⁾
F2 F3 F7 F8	Electronic control unit internal error.	<ul style="list-style-type: none"> ▶ Reset error (press and hold on/off button for 3 seconds). If appliance's configuration is required: ▶ See section 6.5 to configure appliance (region, power, type and gas type) and perform an automatic combustion adjustment according to the section 8.12. ▶ Replace electronic control unit.¹⁾
F9	Gas valve driver internal fault.	<ul style="list-style-type: none"> ▶ Check gas valve wire connections.¹⁾ If the problem persists: ▶ Replace the wire connections and/or electronic control unit.¹⁾
FA	Gas leakage in the gas path (gas valve or gas manifold shut-off valves).	<ul style="list-style-type: none"> ▶ Replace the gas valve and/or gas manifold.¹⁾ ▶ After gas valve and/or gas manifold replacement perform gas and air tuning (→ section 8.12).¹⁾
FC	Control buttons pressed for more than 30s.	<ul style="list-style-type: none"> ▶ Release the button.

Display	Description	Solution
Display show  but without existence of solar thermal system.	Power demand lower than appliance minimum output power.	<ul style="list-style-type: none"> ▶ Increase the hot water flow. ▶ increase the setpoint temperature.
Display show  and water temperature low.		
Display shows “--”	Display is not communicating with Electronic Control Unit.	<ul style="list-style-type: none"> ▶ Reset the appliance by unplugging it for some seconds (at least 10) and plug it back in. ▶ Replace the display and/or wire connections and/or electronic control unit.
High pitch noise (whistling)	Combustion flame with gas in excess or lack of air.	<ul style="list-style-type: none"> ▶ Check if gas type is correct (→ section 6.7).¹⁾ ▶ Check gas inlet pressure (→ section 4.15).¹⁾ ▶ Perform gas and air tuning (→ section 8.11).¹⁾
Low pitch noise with vibration (rumbling)	Combustion flame with air in excess or lack of gas.	<ul style="list-style-type: none"> ▶ Check if gas type is correct (→ section 6.7).¹⁾ ▶ Check gas inlet pressure (→ section 4.15).¹⁾ ▶ Perform gas and air tuning (→ section 8.11).¹⁾

- 1) Only to be carried out by qualified contractors.
- 2) see temperature resistance charts in fig. 63 and 64.
- 3) Reset error by closing and opening all water tap, no restriction.
- 4) Reset error by closing and opening all hot water faucet, limited to 3 times per hour. It can take up to 3 minutes to check for blockage and the appliance to perform the automatic air tuning.

Table 30

Note: If the appliance is locked for safety reasons, information is shown on the display to give more information on the problem. Once the problem is solved, you may have to reset the error (press and hold  button for 3 seconds). To restart the appliance, inside the appliance or in the remote control.

10 Electrical diagram

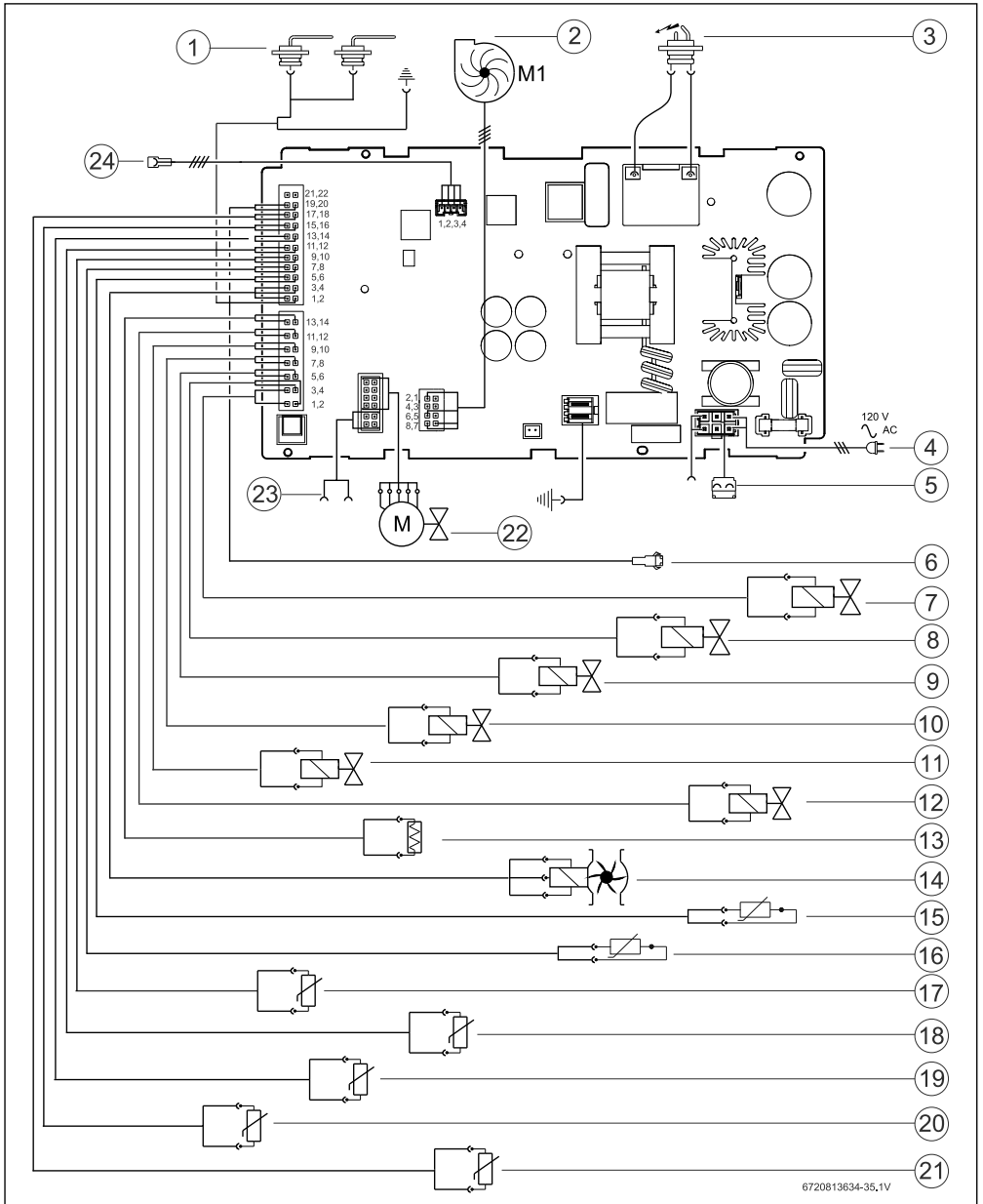

Fig. 62 Electrical diagram

- [1] Ionization sensor
- [2] Fan
- [3] Ignition electrode
- [4] Power supply
- [5] Connection for anti freeze kit
- [6] Connection for remote control
- [7] Gas valve - Modulation
- [8] Water bypass valve
- [9] Electrovalve 3
- [10] Electrovalve 1
- [11] Electrovalve 2
- [12] Gas valve - Solenoide safety
- [13] Thermofuse
- [14] Water flow sensor
- [15] Exhaust temperature sensor
- [16] Exhaust temperature sensor - Between chambers
- [17] Water outlet bypass temperature sensor
- [18] Cabinet temperature sensor
- [19] Water outlet HC temperature sensor
- [20] Water inlet temperature sensor
- [21] Tank temperature sensor
- [22] Water valve
- [23] Connector
- [24] HMI connection

11 Sensor resistance charts

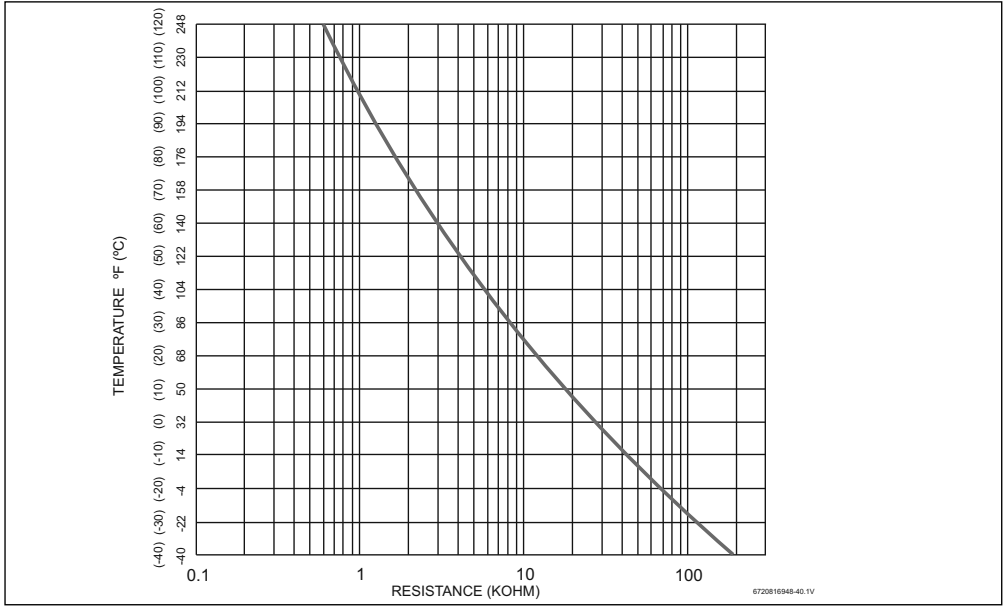

Fig. 63 Inlet, outlet and heat exchanger water temperature sensors characteristics

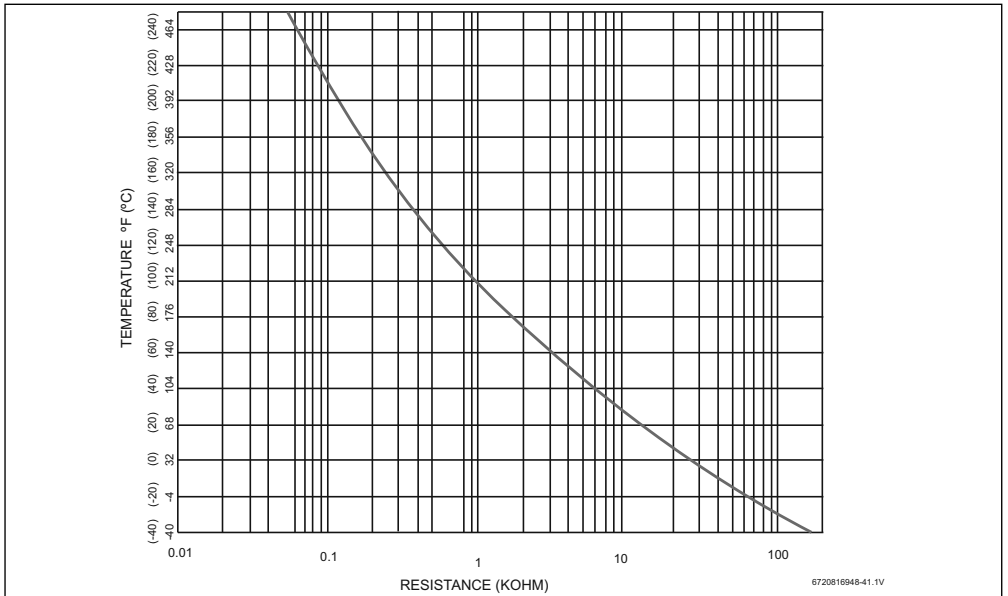
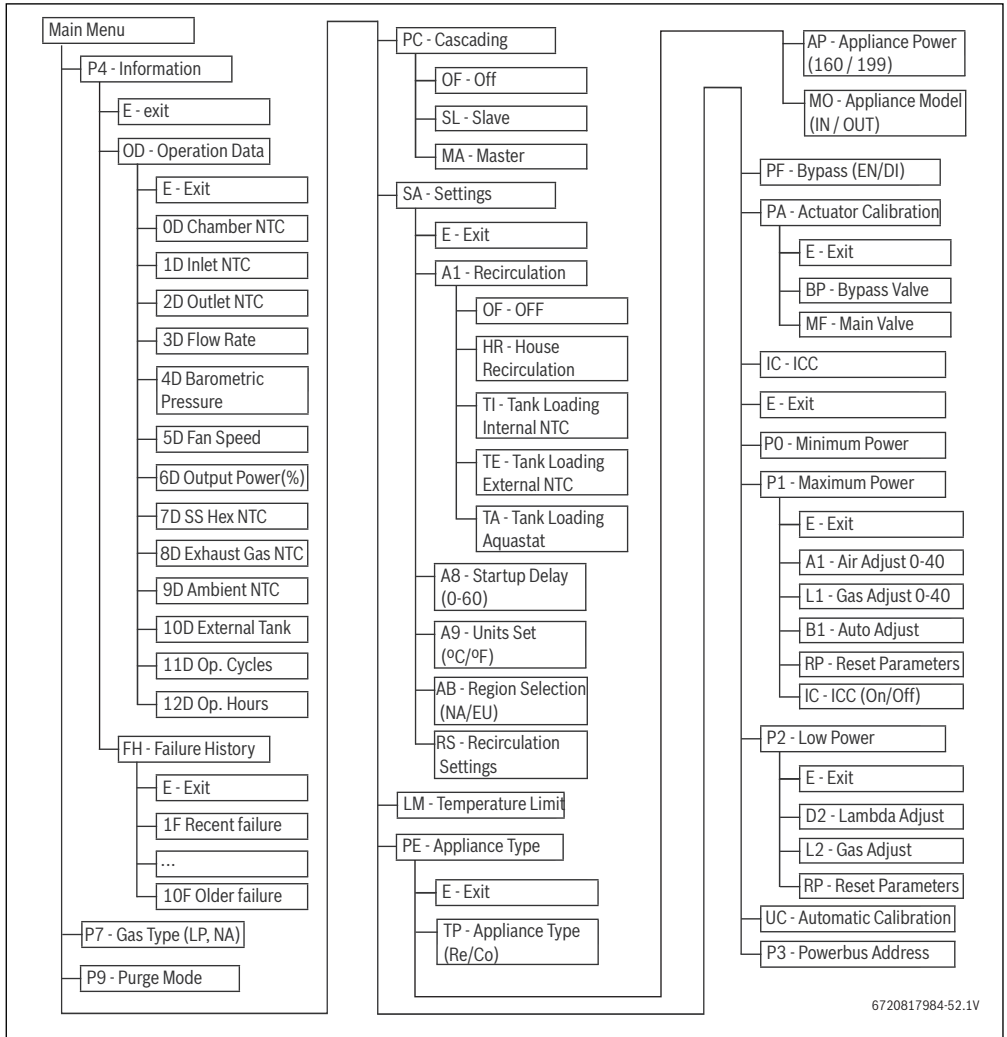

Fig. 64 Flue gases and condensing unit flue gases temperature sensors characteristics

12 Software main menu structure



6720817984-52.1V

Fig. 65

13 Interior components diagram and parts list

13.1 Interior components

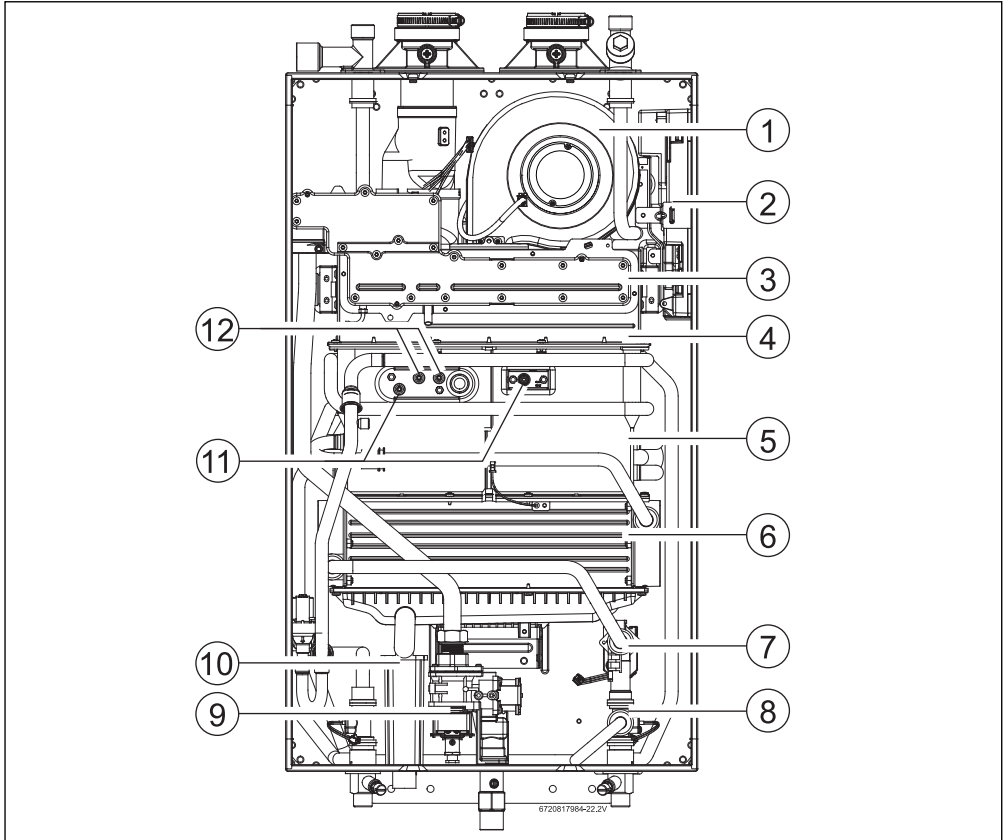

Fig. 66 Components

- [1] Air fan
- [2] Control unit
- [3] Gas manifold
- [4] Burner
- [5] Heat exchanger
- [6] Condensing unit
- [7] Water valve
- [8] By-pass
- [9] Gas valve
- [10] Condensate siphon
- [11] Ionization sensor
- [12] Ignition electrodes

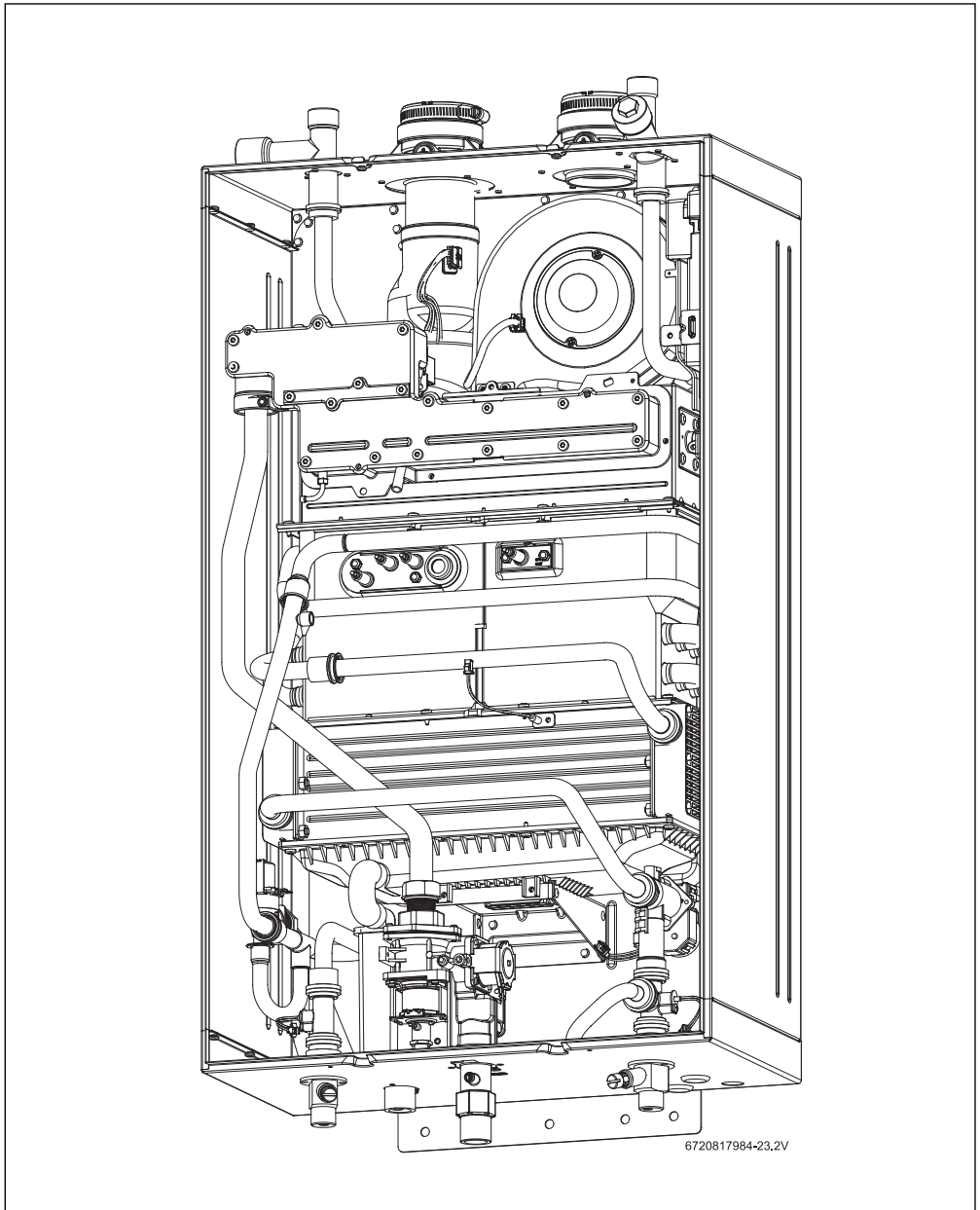



Fig. 67 Appliance overview

14 Protecting the environment



Packing

The packing box may be fully recycled as confirmed by the recycling symbol .

Components

Many parts in the heater can be fully recycled in the end of the product life. Contact your city authorities for information about the disposal of recyclable products.

Saving water resources:

- ▶ Make sure you close all the taps after any use. Avoid leaving the taps dripping. Repair any leaking tap.
- ▶ Define the temperature you want, in the appliance. This way you have the precise water flow needed (mixing cold water to regulate temperature will increase the water flow with consequent waste of water).

15 Installer Checklist to be completed by installer upon installation

Serial Number	_____
Gas Pressure Reading ¹⁾	
Static	
Operating	
Water Pressure	
Building Water Pressure	
Range if on Well system	
Installing Company	
Installer name	
Address	
Phone	

1) See Chapter 4.15, page 43 and gas pressure table (to be filled out by installer)

Table 31



Installation manual should be left with the owner after the installation is tested and completed.

16 LIMITED TANKLESS HEATER WARRANTY

BRADFORD WHITE CORPORATION**LIMITED INFINITI TANKLESS™ K-SERIES WATER HEATER WARRANTY****WHAT DOES THIS LIMITED WARRANTY COVER?**

This limited warranty covers both the heat exchanger and component parts for leakage or other malfunction caused by defects in materials and/or workmanship. It applies to the original consumer purchaser and to any subsequent owner as long as the heater remains installed at its original place of installation.

WHAT DOES THIS LIMITED WARRANTY NOT COVER?

1. This limited warranty does not cover leakage or other malfunctions caused by:
 - a) Defective installation, and specifically, any installation which is made:
 - i) in violation of applicable state or local plumbing, housing or building codes, or
 - ii) without a certified American Gas Association, ASME, or comparable pressure relief valve, or
 - iii) contrary to the written instructions furnished with the unit.
 - b) Adverse local conditions, and specifically sediment or lime precipitate in the heat exchanger; corrosive elements in the atmosphere; or water quality contrary to the written requirements furnished with the unit.
 - c) Misuse, and specifically operations and/or maintenance contrary to the written instructions furnished with the unit, anode removal (if provided), disconnection, alteration or addition of non-approved components or apparatus, operation at settings other than those set forth on the rating plate, or accidental or other exterior damage.
2. This warranty also does not cover:
 - a) Production of noise, taste, odors, discoloration or rusty water.
 - b) Incidental property damage, loss of use, inconvenience or other incidental or consequential costs.
 - c) Costs associated with the replacement and/or repair of the unit, including:
 - i) any freight, shipping or delivery charges
 - ii) any removal, installation or re-installation charges
 - iii) any material, and/or permits required for installation, re-installation or repair
 - iv) charges to return the defective heater and/or component part to the manufacturer.

WHAT IS THE PERIOD OF COVERAGE?

This limited warranty runs from date of installation (or without proof of installation, from three (3) months after the date of manufacture) for the period specified on the following table.

WHAT IS THE DURATION OF THE IMPLIED WARRANTY?

•Restrictions are not applicable to implied warranties in California. See "Special State Provisions" on reverse side.

238-53321-00B (11/18)

FIFTEEN YEAR LIMITED HEAT EXCHANGER WARRANTY*

A no charge* replacement will be provided in the event of a covered failure of the Heat Exchanger.

FIVE YEAR LIMITED PARTS WARRANTY*

All other parts not referenced above are covered for five years from date of original installation.

*Note: Limited heat exchanger warranty fifteen (15) years or 8,000 operational hours; whichever is shorter. Limited parts warranty is five (5) years or 8,000 operational hours; whichever is shorter. A warranty product or part is provided exclusive of labor, freight and/or any installation costs. Any product used for other than a single-family housing unit application will be warranted for only eight (8) years on heat exchanger and five (5) year on parts regardless of any other warranty period specified. All replacement heaters and parts carry the balance of the original warranty, i.e. if an original fifteen (15) year warranted heater develops a leak due to defects in materials/workmanship after only eight (8) years and 5,000 operational hours, the replacement unit is warranted for seven (7) years and 3,000 operational hours in this example.

ANY IMPLIED WARRANTIES, INCLUDING THE WARRANTY OF MERCHANTABILITY IMPOSED ON THE SALE OF THE WATER HEATER UNDER THE LAWS OF THE STATE OF SALE ARE LIMITED IN DURATION TO ONE YEAR FROM DATE OF ORIGINAL INSTALLATION.

HOW DOES STATE LAW RELATE TO THE WARRANTY?

Some states do not allow:

1. Limitations on how long an implied warranty lasts.
2. Limitations on incidental or consequential damages.

So, the above limitations or exclusions may not apply to you.

This warranty gives you specific legal rights, and you may also have other rights which vary from state to state.

Fig. 68

LIMITED TANKLESS HEATER WARRANTY (CONTINUED)

WHAT WILL WE DO TO CORRECT PROBLEMS?

1. If a defect occurs within the heat exchanger warranty period, we will:
Provide a replacement heater of our manufacture, (or at our option) repair any unit, which develops a leak in the heat exchanger within the warranty period. To obtain a replacement, you must forward both the rating plate from the defective unit to us and a copy of the original sales receipt. If government regulations require the replacement heater to have features not found in the defective heater, you will be required to pay the difference in price represented by those government required features.
2. If a defect occurs within the parts warranty period, we will:
Provide a replacement part (or at our option repair) any part which fails to function within the parts warranty period. To obtain a replacement, you must forward the defective part to us. If government regulations require the replacement part to have features not found in the defective part, you will be required to pay the difference in price represented by those government required features.

We do reserve the right to verify any claims of defect by inspection.

WHAT WILL WE NOT DO?

We will not:

1. Repair or replace any heater, or part, subject to conditions outlined in "What Does This Limited Warranty Not Cover?"
2. Reimburse any costs associated with repair and/or replacement.
3. Replace and/or repair any heater without complete model/serial number.
4. Replace any heater without prior receipt of actual rating plate from appliance and copy of original sales receipt.

HOW DO YOU GET WARRANTY ASSISTANCE?

Upon discovering a defect or problem, you should:

1. Contact either the Installer or dealer, or
2. Contact us--
BRADFORD WHITE CORPORATION
WARRANTY SUPPORT GROUP
445 EAGLE DR.
MIDDLEVILLE, MI 49333
1-800-531-2111

WHAT SHOULD YOU DO TO KEEP THE WARRANTY IN EFFECT?

To facilitate warranty assistance, you should:

1. Follow all instructions enclosed with the product.
2. Retain all bills of sale or receipts for proof of installation, etc.
3. Contact your installer, dealer or our Warranty Department as soon as any problem or defect is noticed.
4. When necessary, allow us, or our chosen representative, to inspect the unit.
5. For your reference, fill in the Model and Serial Number found on the units Rating Plate:

Model Number _____

Serial Number _____

Date of Installation _____

Name of Installer _____

SPECIAL STATE PROVISIONS

For heaters installed in California or Oregon, Paragraphs 2(c) (i) (iv) of the paragraph "WHAT DOES THIS WARRANTY NOT COVER?" does not apply.
All other terms and conditions of this warranty apply as stated.

PLEASE RETAIN THIS WARRANTY IN A SAFE LOCATION FOR FUTURE REFERENCE.

238-53321-00B (11/18)

Fig. 69









6720817984



BRADFORD WHITE®
W A T E R H E A T E R S

Ambler, PA

For U.S. and Canada field service,
Contact your professional installer or
local Bradford White representative.

Sales/**800-523-2931**
Fax/215-641-1670
Parts Fax/215-641-2180

Technical Support/**800-334-3393**
Fax/269-795-1089

Warranty/**800-531-2111**
Fax/269-795-1089

International:
Telephone/**215-641-9400**
Telefax/215-641-9750



BRADFORD WHITE-CANADA™ INC.
A SUBSIDIARY OF BRADFORD WHITE CORPORATION

Mississauga, ON

Sales/**866-690-0961**
905-238-0100

Fax/905-238-0105
Technical Support/**800-334-3393**

Email
parts@bradfordwhite.com
techserv@bradfordwhite.com

www.bradfordwhite.com