

## TankMixer™ water heater tank mixing valve

© Copyright 2020 Caleffi

### 520 Series

#### Function



The Caleffi TankMixer™ 520\_AX series kit combines a three-way thermostatic mixing valve with a cold water cross and flexible pipe for easy installation directly on a typical gas-fired water heater and other water heaters that now comply with the National Appliance Energy Conservation Act (NAECA). The TankMixer maintains the desired output temperature of the mixed water supplied at a constant set value compensating for both temperature and pressure fluctuations of the incoming hot and cold water. The mixing valve also features a thermal shut-off function that operates in the event of a cold water supply failure at the inlet. Also available as body only, for a wide variety of separately-sourced end connections, the angle style body design offers improved fluid dynamics for better performance and reduces installation labor and materials, eliminating a piping elbow in typical installations. The valve ICC-ES certified to ASSE 1017 and CSA B125.3. It complies with codes IPC, IRC, NPC and UPC for use in accordance with the US and Canadian plumbing codes, and standard NSF/ANSI 372, low lead.

#### Product range

52050\_AX series kit: Adjustable three-way thermostatic mixing valve, angle body with cold water cross and flexible connector, connections ¾" NPT female to water heater; ¾" sweat, press, and NPT male union mix outlet/cold water inlet.

52051\_AX series kit: 52050\_AX series kit with mixed outlet temperature gauge.

520051A: Adjustable three-way thermostatic mixing valve, angle style body only for field installed connection fittings, source separately, connections 1" male union.

#### Technical specification

##### Materials

-Valve and cold water cross bodies:	DZR low-lead brass	Max. hot water inlet temperature:	195°F(90°C)
-Shutter, seats and slide guides:	PSU	Max. inlet pressure ratio (H/C or C/H) for optimal performance:	2:1
-Springs:	stainless steel	Min. temperature difference between hot water inlet and mixed water outlet for optimal performance:	27°F(15°C)
-Seals:	EPDM	Min. flow to ensure optimal performance:	0.5 gpm (2 L/min)
-Adjustment knob:	ABS		
-Flexible pipe:	stainless steel		
-Recirc. port plug:	low-lead brass		

##### Certifications:

1. ASSE 1017/CSA B125.3, certified by ICC-ES, file PMG-1357.
2. Complies with NSF/ANSI 372, Drinking Water System Components-Lead Content Reduction of Lead in Drinking Water Act, California Health and Safety Code 116875 S.3874, Reduction of Lead in Drinking Water Act, as certified by ICC-ES, file PMG-1360.

##### Performance

Suitable fluids:	water
Setting range:	5–150° F (35–65° C)
Tolerance:	±3° F (±2° C)

Max. working pressure (static): 150 psi (10 bar)  
 Max. working pressure (dynamic): 75 psi (5 bar)



## SAFETY INSTRUCTION

This safety alert symbol will be used in this manual to draw attention to safety related instructions. When used, the safety symbol means **ATTENTION! BECOME ALERT! YOUR SAFETY IS INVOLVED! FAILURE TO FOLLOW THESE INSTRUCTIONS MAY RESULT IN A SAFETY HAZARD.**



**WARNING:** This product can expose you to chemicals including lead, which is known to the State of California to cause cancer and birth defects or other reproductive harm. For more information go to [www.P65Warnings.ca.gov](http://www.P65Warnings.ca.gov).



**CAUTION:** All work must be preformed by qualified personnel trained in the proper application, installation, and maintenance of systems in accordance with all applicable codes and ordinances.



**CAUTION:** If the thermostatic mixing valve is not installed, commissioned and maintained properly, according to the instructions contained in this manual, it may not operate correctly and may endanger the user.



**CAUTION:** Make sure that all the connecting pipework is water tight.



**CAUTION:** When making the water connections, make sure that the pipework connecting the TankMixer thermostatic mixing valve is not mechanically overstressed. Over time this could cause breakages, with consequent water losses which, in turn, could cause harm to property and/or people.



**CAUTION:** Water temperatures higher than 100°F (38°C) can be dangerous. During the installation, commissioning and maintenance of the TankMixer thermostatic mixing valve, take the necessary precautions to ensure that such temperatures do not endanger people.



**CAUTION:** To prevent any damage which will cause the electronic mixing valve to not operate correctly, treat highly aggressive water before entering the thermostatic mixing valve. Be sure water hardness is less than 10 grains.



**CAUTION:** If installed in an ASSE 1017 application, check valves shall be used.

Caleffi shall not be liable for damages resulting from stress corrosion, misapplication or misuse of it products.

**LEAVE THIS MANUAL WITH THE USER.**



## CONSIGNE DE SÉCURITÉ

Ce symbole d'avertissement servira dans ce manuel à attirer l'attention sur la sécurité concernant instructions. Lorsqu'il est utilisé, ce symbole signifie.

**ATTENTION! DEVEZ-VOUS ÊTRE ALERTES ! VOTRE SÉCURITÉ EST EN JEU ! NE PAS SUIVRE CES INSTRUCTIONS PEUT PROVOQUER UN RISQUE DE SÉCURITÉ.**



**AVERTISSEMENT:** Ce produit peut vous exposer à des produits chimiques comme le plomb, qui est connu dans l'État de Californie pour causer le cancer, dommages à la naissance ou autre. Pour plus d'informations rendez-vous [www.P65Warnings.ca.gov](http://www.P65Warnings.ca.gov).



**ATTENTION:** Tous les travaux doivent être effectués par du personnel qualifié formé à la bonne application, installation et maintenance des systèmes conformément aux codes et règlements locaux.



**ATTENTION:** Si le réducteur de pression, thermostatique réglable, n'est pas installé, mis en service et entretenu correctement, selon les instructions contenues dans ce manuel, il peut ne pas fonctionner correctement et peut mettre en danger l'utilisateur.



**ATTENTION:** S'assurer que tous les raccordements sont étanches.



**ATTENTION:** Lorsque vous effectuez les raccordements d'eau, assurez-vous que la tuyauterie reliant le TankMixer thermostatique réglable n'est pas mécaniquement overstressed. Au fil du temps, ceci pourrait causer des ruptures, avec pour conséquence des pertes en eau qui, à leur tour, peuvent causer des dommages à la propriété et/ou les gens.



**ATTENTION:** Les températures de l'eau supérieures à 100°F (38°C) peuvent être dangereuses. Au cours de l'installation, mise en service et l'entretien de le réducteur de pression, le TankMixer thermostatique réglable, prendre les précautions nécessaires afin de s'assurer que de telles températures ne compromettent pas les gens.



**ATTENTION:** Pour prévenir tout dommage qui provoque le mitigeur électronique à ne pas fonctionner correctement, le traitement de l'eau très agressive avant d'entrer dans la thermostatique réglable. Assurez-vous que la dureté de l'eau est inférieure à 10 grains.



**ATTENTION:** S'il est installé dans un pays de ASSE 1017 application, vérifiez les robinets doivent être utilisés.

Caleffi ne pourra être tenue responsable des dommages résultant de la corrosion, d'une mauvaise utilisation ou une mauvaise utilisation des produits.

**LAISSEZ CE MANUEL AVEC L'UTILISATEUR**

## Operating principle

The thermostatic mixing valve mixes the hot and cold water at the inlets to maintain constant mixed water at the desired set temperature. The TankMixer 520 series point of distribution mixing valve is an angled configuration combined with a flexible hose and cold water cross for easy installation to most water heaters for direct mounting to the universal 3/4" male NPT threaded top pipe connections with a variety of outlet connection styles. This provides increased usable hot water capacity on existing or new high efficiency water heaters by allowing water to be stored at a higher temperature and safely delivered at lower adjustable temperatures to all fixtures. In addition, it can be used to reduce legionella growth by allowing the water heater thermostat to be set at 140°F. The flexible hose length allows mounting to all water heater tank sizes. The TankMixer 520\_AX series comes standard with a recirculation port that can be plugged or used for connecting to a hot water recirculation loop.

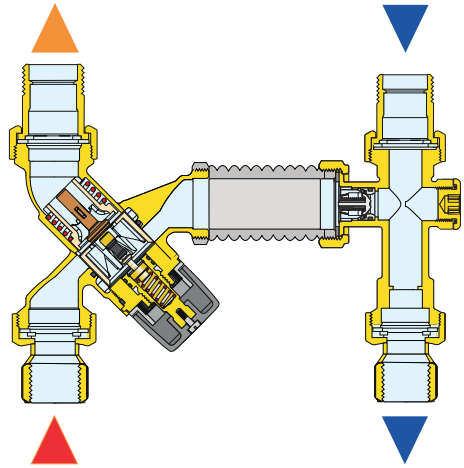

## Flow curve

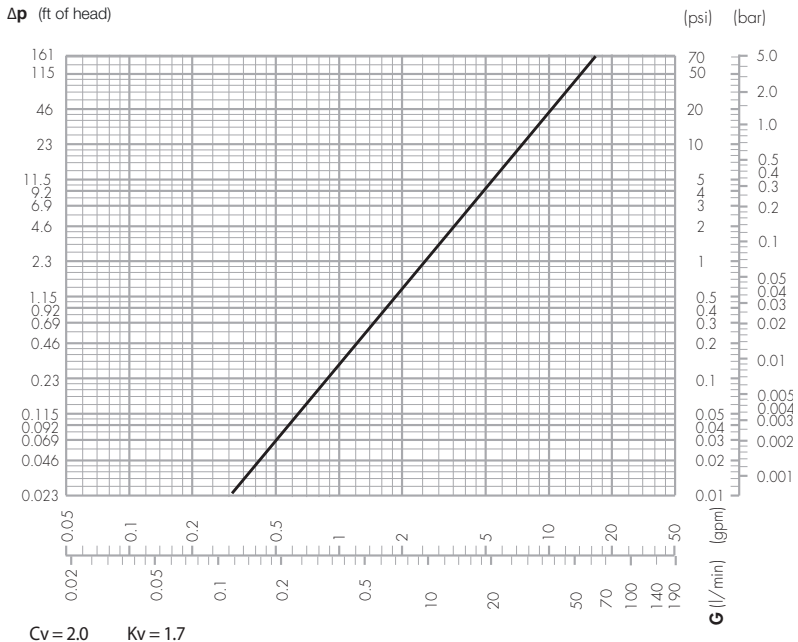

## Use



Caleffi TankMixer 520 series thermostatic mixing valves are designed to be installed at the hot water heater. The 520 series valve cannot be used for tempering water temperature at fixtures as a point-of-use valve. They are not designed to provide scald protection or chill protection service. They should not be used where ASSE 1070 devices are required. Wherever a scald protection feature is required, Caleffi 5213 series high performance mixing valves need to be installed. For safety reasons, it is advisable to limit the maximum mixed water temperature to 120°F when anti-scald devices are not used at each fixture.

## Water heater

As a result of the NAECA, many water heaters now have more insulation making them physically larger, for the same water capacity, than the older models. So units with less capacity are installed requiring higher temperature settings to provide the capacity users were previously accustomed, requiring mixing valves to temper the water to safe levels.

Caleffi TankMixer 520\_AX series thermostatic mixing valves with cold water cross assembly and flexible connector will conveniently fit a typical gas-fired water heater and a wide variety of other water heaters. A recirculation return can be connected at the side port of the cold water cross.

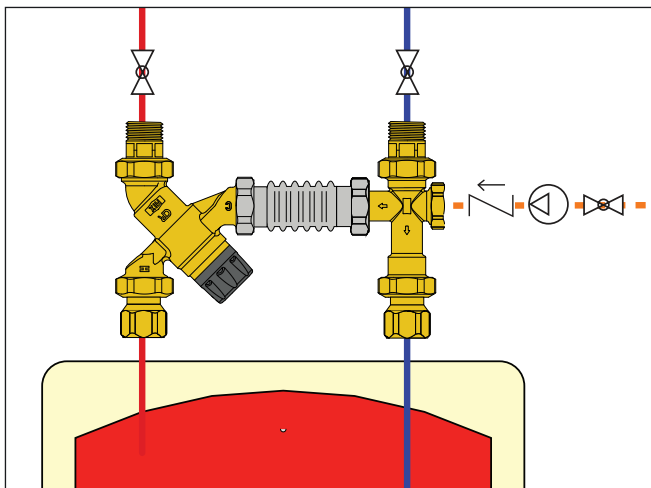

## Construction details

### Thermal shut-off

In the event of accidental cold water supply failure, the shutter seals off the hot water passage, thus preventing the delivery of mixed temperature water. This is only guaranteed when there is a minimum temperature difference between the inlet hot water and the mixed temperature water delivery of 27°F.

## Installation



Before installing a Caleffi TankMixer 520 series three-way thermostatic mixing valve, the system must be inspected to ensure that its operating conditions are within the range of the mixing valve, checking, for example, the supply temperature, supply pressure, etc.

Systems where the 520 series thermostatic mixing valve will be installed must be drained and cleaned out to remove any dirt or debris which may have accumulated during installation.

The installation of appropriately sized filters at the inlet from the main water supply is always advisable.

Caleffi TankMixer 520 series thermostatic mixing valves must be installed by qualified personnel in accordance with the diagrams in this brochure, taking into account all current applicable standards.

Caleffi TankMixer 520 series thermostatic mixing valves can be installed in any position, either vertical or horizontal, or upside down.

The following are shown on the thermostatic mixing valve body:

- Hot water inlet, color red and marked "HOT".
- Cold water inlet, color blue and marked "COLD".
- Mixed water outlet, marked "MIX".



## Locking the setting

Position the handle to the number required with respect to the index point. Unscrew the head screw, pull off the handle and reposition it so that the handle fits into the internal slot of the knob. Tighten the head screw.

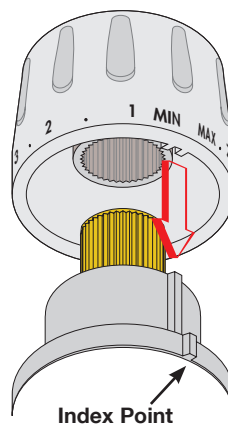

## Check valve

In systems with thermostatic mixing valves, check valves should be installed to prevent undesired backflow. The TankMixer 520\_AX series mixing valves are supplied complete with a check valve on the cold water cross outlet port to the mixing valve. As a convenience for easier installations, the TankMixer 520051A body only can be field-installed with separately purchased union tailpieces for ½", ¾" or 1" npt female or male, press, PEX barb or sweat with or without check valves (for the hot and cold inlet ports).

## Dimensions

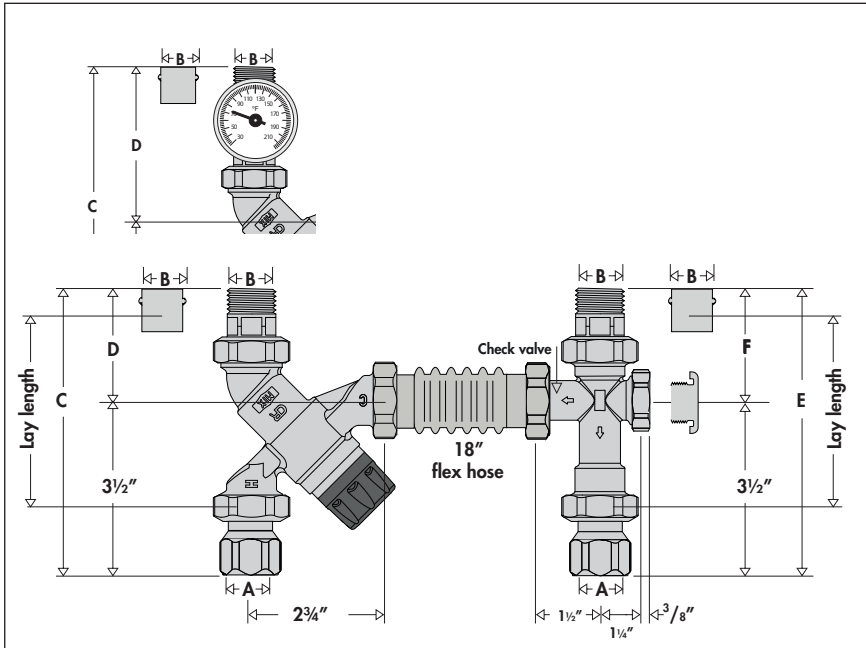

No temperature gauge.

Code	A	B	C	D	E	F	Wt. (lb.)
520500AX	$\frac{3}{4}$ " nptf	$\frac{3}{4}$ " nptm	$5\frac{9}{16}$ "	$2\frac{1}{4}$ "	$5\frac{5}{8}$ "	$2\frac{1}{4}$ "	2.4
520506AX	$\frac{3}{4}$ " nptf	$\frac{3}{4}$ " press	$5\frac{13}{16}$ "	$2\frac{9}{16}$ "	$5\frac{7}{8}$ "	$2\frac{9}{16}$ "	2.4
520509AX	$\frac{3}{4}$ " nptf	$\frac{3}{4}$ " swt	$5\frac{1}{2}$ "	$2\frac{9}{16}$ "	$5\frac{1}{2}$ "	$2\frac{9}{16}$ "	2.4

Lay length (hot inlet to mix outlet) for press:  $3\frac{3}{8}$ "; for sweat:  $3\frac{3}{8}$ ".

With temperature gauge.

Code	A	B	C	D	E	F	Wt. (lb.)
520510AX	$\frac{3}{4}$ " nptf	$\frac{3}{4}$ " nptm	$7\frac{7}{8}$ "	$4\frac{1}{4}$ "	$5\frac{5}{8}$ "	$2\frac{1}{4}$ "	2.9
520516AX	$\frac{3}{4}$ " nptf	$\frac{3}{4}$ " press	8"	$4\frac{9}{16}$ "	$5\frac{7}{8}$ "	$2\frac{9}{16}$ "	2.9
520519AX	$\frac{3}{4}$ " nptf	$\frac{3}{4}$ " swt	$7\frac{3}{4}$ "	$4\frac{3}{16}$ "	$5\frac{1}{2}$ "	$2\frac{9}{16}$ "	2.9

Lay length (hot inlet to mix outlet) for press:  $5\frac{9}{16}$ "; for sweat:  $5\frac{9}{16}$ ".

## Commissioning

The Caleffi TankMixer 520 series thermostatic mixing valve must be commissioned in accordance with current standards by qualified personnel using temperature measuring equipment. Caleffi 520510AX, 520516AX and 5210519AX with integral outlet port temperature gauge provide a time-saving temperature setting process to get close to the desired temperature. Use of a digital thermometer is recommended for confirming the final setting of the mixed water temperature. Note: For models purchased without the outlet temperature gauge, the temperature gauge adapter with temperature gauge can be separately purchased and field installed, code NA10056 for 3/4" models.

After installation, the valve must be tested and commissioned in accordance with instructions given below, taking into account current applicable standards.

- 1) Ensure that the system is clean and free from dirt or debris before commissioning the thermostatic mixer.
- 2) It is recommended that the temperature is set using a suitable calibrated digital thermometer. The valve must be commissioned by measuring the temperature of the mixed water emerging at the point of use.
- 3) The maximum outlet temperature from the valve must be set accounting for fluctuations due to simultaneous use. It is essential for these conditions to be stabilized before commissioning.
- 4) Adjust the temperature using the adjusting knob on the valve. For safety reasons, it is advisable to limit the maximum mixed water temperature to 120°F in domestic hot water systems.
- 5) The temperature may be adjusted using the control knob.
  - a) Adjust the temperature of the mixed water to the desired value.
  - b) Measure and record the temperature at the cold and hot water inlets.
  - c) Measure and record the temperature of the water delivered from the tap at the lowest and highest flow rates.
  - d) Run a test of the thermal shut-off function. Close the cold water inlet shut-off valve and check the mixed water delivery. The delivery flow rate should quickly drop to zero.
  - e) Measure and record the maximum mixed water temperature. The temperature may not exceed the values permitted in any applicable legislation or code of practice.
  - f) Restore the cold water inlet supply and measure the water delivery temperature after it has stabilized. The final temperature measured in this test may not exceed the permitted values by  $\pm 3^{\circ}\text{F}$  ( $\pm 2^{\circ}\text{C}$ ).

In case of change to temperature setting, repeat tests in accordance with points d, e, f. All the above information should be recorded in the commissioning report and updated in the maintenance report whenever the valve is worked on.

## Temperature setting and locking

The control knob permits temperature setting between minimum and maximum in one turn (360°). It also has a tamper-proof system to lock the temperature at the set value. The temperature is set to the required value by means of the knob with the graduated scale, on the top of the valve.

Pos.	Min.	1	2	3	4	5	6	7	Max.
T (°F)	95	105	115	120	125	132	140	145	150
T (°C)	35	40	45	48	52	56	60	63	65

with:  $T_{HOT} = 158^{\circ}\text{F}$  ( $70^{\circ}\text{C}$ ), with:  $T_{cold} = 59^{\circ}\text{F}$  ( $15^{\circ}\text{C}$ ),  $P = 43$  psi (3 bar)



# Application diagrams

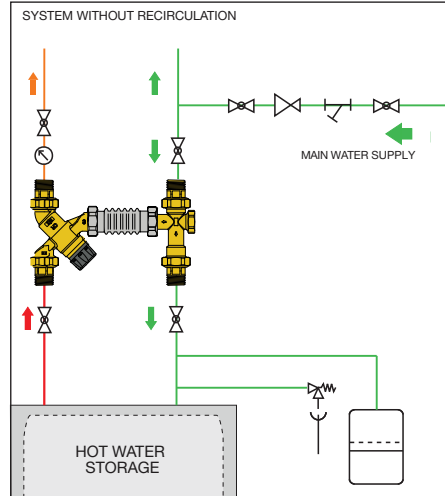
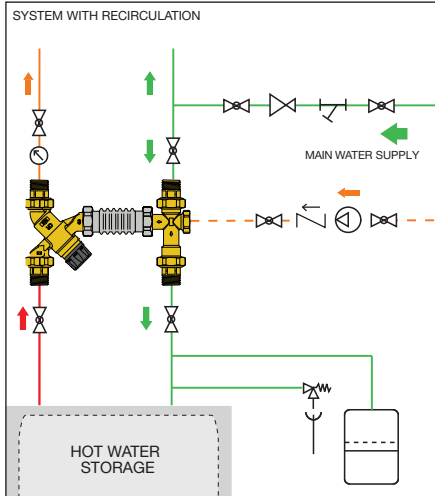

- Ball valve
- Ball valve with check valve
- Temperature gauge
- Pump
- Expansion vessel
- Thermostat
- Temperature/pressure safety relief valve
- Safety relief valve
- Pressure reducing valve
- Y-strainer

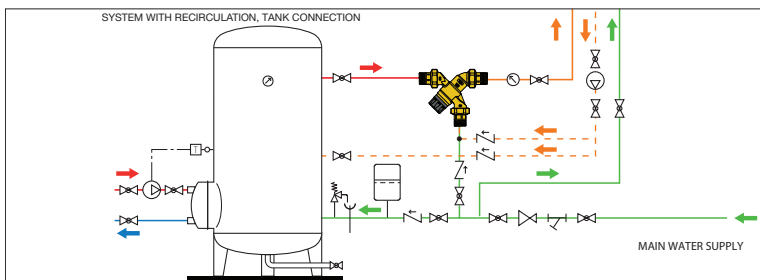
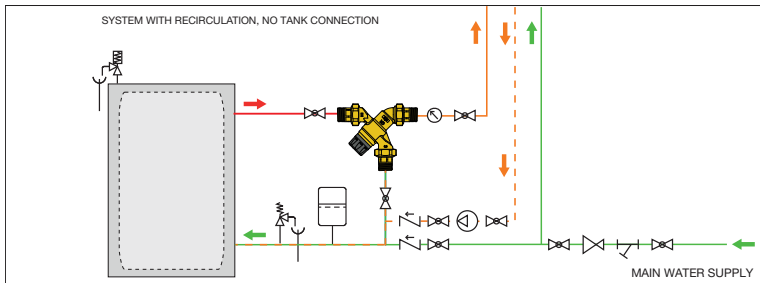
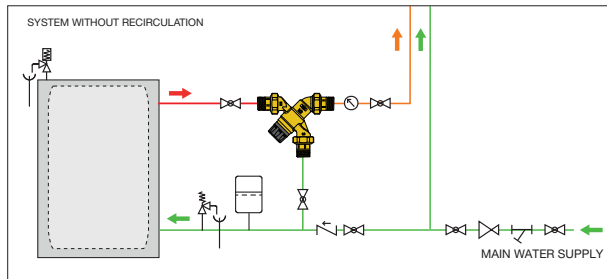

## Troubleshooting

Under normal operating conditions the Caleffi TankMixer 520 series thermostatic mixing valve will provide a very high level of performance. However, in some circumstances, where the following maintenance schedule is not followed problems may arise.

### Recommended maintenance schedule:

Tests should be conducted regularly to monitor the thermostatic mixing valve performance, as deterioration of performance could indicate that the valve and/or the system require maintenance. If, during these tests, the temperature of the mixed water has changed significantly in comparison with the previous test, the details given in the installation and commissioning sections should be checked and maintenance conducted.

The following should be checked regularly to ensure that the optimum performance levels of the valve are maintained. Check every 12 months at least, or more often if necessary.

- 1) Check and clean the system filters.
- 2) Check that any check valves positioned upstream of the Caleffi thermostatic mixing valve are operating correctly, without problems caused by impurities.
- 3) Limescale can be removed from internal components of the thermostatic mixing valve by immersion in a suitable de-scaling fluid.
- 4) When the components which can be maintained have been checked, commission the valve.

Symptoms	Cause	Corrective action
Hot water at the cold taps	a) Operation of check valve is hindered; Check valve is not sealing correctly. b) Check valves not fitted.	- Replace faulty check valve
Fluctuating mixed water temperature	a) Erratic supply temperatures at the inlet of the valve. b) Starvation of the water supplies at the inlets of the valve. c) Incorrect commissioning of the valve.	- Restore inlet conditions within the limits of the valve.
Erratic flow of water from the valve	a) Insufficient water supplies b) Fluctuations in the supply pressures/temperatures. c) Adverse effect created by other draw off points on the system	- Stabilize inlet supply conditions.
No flow of water from the valve	a) In-line filters blocked. b) Insufficient supply pressures. c) Debris obstructing valve operation.	- Clean filters - Restore inlet supplies - Clean debris or scale from the valve.
Valve shut-off function not performed when tested	a) Installation not compliant with instructions. b) Minimum temperature difference not reached. c) Valve mechanism blocked by dirt.	- Follow installation instructions. - Increase hot water temperature. - Remove dirt/limescale from the valve.

# NOTES



**Caleffi North America, Inc.**  
**3883 West Milwaukee Road**  
**Milwaukee, WI 53208**  
**T: 414.238.2360 F: 414.238.2366**

12-15-20