

**SLZ-KF15NA & SUZ-KA15NA2**  
**15,000 BTU/H 2' X 2' 4-WAY CEILING CASSETTE**  
**15,000 BTU/H HEAT PUMP UNIVERSAL OUTDOOR UNIT**



Job Name:

System Reference:

Date:



Indoor Unit.....SLZ-KF15NA

Outdoor Unit.....SUZ-KA15NA2



**INDOOR UNIT FEATURES**

- Ceiling-recessed cassette (24"x24") ductless heat pump
- Install Konnect Series in a drywalled ceiling (with an access panel for servicing) or in a 2'x2' drop ceiling
- Wide airflow pattern for excellent air distribution
- Optional 3D i-see Sensor®
- Fresh air intake provided in the main body
- Built-in drain condensate lift mechanism (lifts to 33")
- Multiple control options available:
  - kumo cloud® smart device app for remote access
  - Third-party interface options
  - Wired or wireless controllers
- Long-life air filter included
- Individual vane control

**OUTDOOR UNIT FEATURES**

- Variable speed INVERTER-driven compressor
- Innovative Joint Lap DC Motor leads to high efficiency and reliability
- Pulse Amplitude Modulation technology
- High-performance grooved piping for increased heat exchange efficiency

# SPECIFICATIONS: SLZ-KF15NA & SUZ-KA15NA2

Cooling at 95°F <sup>1</sup>	Maximum Capacity	BTU/H	14,100
	Rated Capacity	BTU/H	14,100
	Minimum Capacity	BTU/H	5,100
	Maximum Power Input	W	1,150
	Rated Power Input	W	1,150
	Moisture Removal	Pints/h	3.2
	Sensible Heat Factor		0.75
Heating at 47°F <sup>2</sup>	Power Factor	%	98.0/98.0
	Maximum Capacity	BTU/H	19,100
	Rated Capacity	BTU/H	18,000
	Minimum Capacity	BTU/H	5,100
	Maximum Power Input	W	1,980
	Rated Power Input	W	5,100
Heating at 17°F <sup>3</sup>	Power Factor	%	98.0/98.0
	Maximum Capacity	BTU/H	11,900
	Rated Capacity	BTU/H	11,900
	Maximum Power Input	W	1,290
Heating at 5°F <sup>4</sup>	Rated Power Input	W	1,290
	Maximum Capacity	BTU/H	8,900
Heating at -4°F <sup>5</sup>	Maximum Power Input	W	1,140
	Maximum Capacity	BTU/H	5,800
Efficiency	SEER		19.8
	EER <sup>1</sup>		12.2
	HSPF [IV]		11.2
	COP at 47°F <sup>2</sup>		3.0
	COP at 17°F at Maximum Capacity <sup>3</sup>		2.7
	COP at 5°F at Maximum Capacity <sup>4</sup>		2.29
Electrical	ENERGY STAR <sup>®</sup> Certified		No
	Voltage, Phase, Frequency		208/230, 1, 60
	Guaranteed Voltage Range	V AC	187 - 253
	Voltage: Indoor - Outdoor, S1-S2	V AC	208/230
	Voltage: Indoor - Outdoor, S2-S3	V DC	24
	Short-circuit Current Rating [SCCR]	kA	5
	Recommended Fuse/Breaker Size (Outdoor)	A	15
	Recommended Wire Size [Indoor - Outdoor]	AWG	14
Power Supply		Indoor unit is powered by the outdoor unit	
Indoor Unit	MCA	A	0.4
	Fan Motor Full Load Amperage	A	0.32
	Fan Motor Output	W	50
	Fan Motor Type		DC Motor
	Airflow Rate at Cooling, Dry	CFM	245-315-405
	Airflow Rate at Cooling, Wet	CFM	221-284-365
	Airflow Rate at Heating, Dry	CFM	245-315-405
	Sound Pressure Level [Cooling]	dB[A]	27-34-39
	Sound Pressure Level [Heating]	dB[A]	27-34-39
	Drain Pipe Size	In. [mm]	1-1/4 [32]
	Condensate Lift Mechanism, Maximum Distance	In. [mm]	33 [850]
	Coating on Heat Exchanger		—
	External Finish Color		Munsell 1.0Y 9.2/0.1
	Unit Dimensions	W x D x H: In. [mm]	22-7/16 x 22-7/16 x 9-21/32 [570 x 570 x 245]
Package Dimensions	W x D x H: In. [mm]	24-13/32 x 27-15/16 x 9-7/16 [620 x 710 x 240]	
Unit Weight	Lbs. [kg]	31 [13.9]	
Package Weight	Lbs. [kg]	37 [17]	
Indoor Unit Operating Temperature Range	Cooling Intake Air Temp [Maximum / Minimum]*	°F	90 DB, 72 WB / 68 DB, 61 WB
	Heating Intake Air Temp [Maximum / Minimum]	°F	77 DB / 59 DB

**NOTES:**

AHRI Rated Conditions (Rated data is determined at a fixed compressor speed)

<sup>1</sup> Cooling (Indoor // Outdoor)	°F	80 DB, 67 WB // 95 DB, 75 WB
<sup>2</sup> Heating at 47°F (Indoor // Outdoor)	°F	70 DB, 60 WB // 47 DB, 43 WB
<sup>3</sup> Heating at 17°F (Indoor // Outdoor)	°F	70 DB, 60 WB // 17 DB, 15 WB

Conditions

<sup>4</sup> Heating at 5°F (Indoor // Outdoor)	°F	70 DB, 60 WB // 5 DB, 4 WB
<sup>5</sup> Heating at -4°F (Indoor // Outdoor)	°F	70 DB, 60 WB // -4 DB, -5 WB
<sup>6</sup> Heating at -5°F (Indoor // Outdoor)	°F	70 DB, 60 WB // -5 DB, -6 WB
<sup>7</sup> Heating at -13°F (Indoor // Outdoor)	°F	70 DB, 60 WB // -13 DB, -14 WB

\*Outdoor Unit Operating Temperature Range (Cooling Air Temp (Maximum / Minimum)):

- Applications should be restricted to comfort cooling only; equipment cooling applications are not recommended for low ambient temperature conditions.

\*\*Outdoor Unit Operating Temperature Range (Cooling Thermal Lock-out / Re-start Temperatures; Heating Thermal Lock-out / Re-start Temperatures):

- System cuts out in heating mode to avoid thermistor error and automatically restarts at these temperatures.

## SPECIFICATIONS: SLZ-KF15NA & SUZ-KA15NA2

Outdoor Unit	MCA	A	10.0
	MOCP	A	18
	Fan Motor Full Load Amperage	A	0.5
	Fan Motor Output	W	55
	Airflow Rate	CFM	1243/1229
	Refrigerant Control		LEV
	Defrost Method		Reverse Cycle
	Coating on Heat Exchanger		Blue Fin Coating
	Sound Pressure Level, Cooling <sup>1</sup>	dB(A)	49
	Sound Pressure Level, Heating <sup>2</sup>	dB(A)	51
	Compressor Type		DC INVERTER-driven Twin Rotary
	Compressor Model		SNB130FQBMT
	Compressor Rated Load Amps	A	7.4
	Compressor Locked Rotor Amps	A	9.3
	Compressor Oil Type // Charge	oz.	FV50S // 11.8
	External Finish Color		Ivory Munsell 3Y 7.8/1.1
	Base Pan Heater		Optional
	Unit Dimensions	W x D x H: In. [mm]	31-1/2 x 11-1/4 x 21-5/8 [800 x 285 x 550]
	Package Dimensions	W x D x H: In. [mm]	37 x 14-15/16 x 24-13/16 [940 x 380 x 630]
	Unit Weight	Lbs. [kg]	81 [37]
Package Weight	Lbs. [kg]	88 [40]	
Outdoor Unit Operating Temperature Range	Cooling Air Temp [Maximum / Minimum]*	°F	115 DB / 14 DB
	Cooling Thermal Lock-out / Re-start Temperatures**	°F	-1 / 3
	Heating Thermal Lock-out / Re-start Temperatures**	°F	-9 / -4
Refrigerant	Type		R410A
	Charge	Lbs, oz	2, 9.0
	Chargeless Piping Length	Ft. [m]	23.0 [7.0]
	Additional Refrigerant Charge Per Additional Piping Length	oz./Ft. [g/m]	0 [0]
Piping	Gas Pipe Size O.D. [Flared]	In.[mm]	1/2 [12.7]
	Liquid Pipe Size O.D. [Flared]	In.[mm]	1/4 [6.35]
	Maximum Piping Length	Ft. [m]	65 [20]
	Maximum Height Difference	Ft. [m]	40 [12]
	Maximum Number of Bends		10

**NOTES:**

AHRI Rated Conditions  
 (Rated data is determined at a fixed compressor speed)

<sup>1</sup> Cooling (Indoor // Outdoor)	°F	80 DB, 67 WB // 95 DB, 75 WB
<sup>2</sup> Heating at 47°F (Indoor // Outdoor)	°F	70 DB, 60 WB // 47 DB, 43 WB
<sup>3</sup> Heating at 17°F (Indoor // Outdoor)	°F	70 DB, 60 WB // 17 DB, 15 WB

Conditions

<sup>4</sup> Heating at 5°F (Indoor // Outdoor)	°F	70 DB, 60 WB // 5 DB, 4 WB
<sup>5</sup> Heating at -4°F (Indoor // Outdoor)	°F	70 DB, 60 WB // -4 DB, -5 WB
<sup>6</sup> Heating at -5°F (Indoor // Outdoor)	°F	70 DB, 60 WB // -5 DB, -6 WB
<sup>7</sup> Heating at -13°F (Indoor // Outdoor)	°F	70 DB, 60 WB // -13 DB, -14 WB

\*Outdoor Unit Operating Temperature Range (Cooling Air Temp (Maximum / Minimum)):

- Applications should be restricted to comfort cooling only; equipment cooling applications are not recommended for low ambient temperature conditions.

\*\*Outdoor Unit Operating Temperature Range (Cooling Thermal Lock-out / Re-start Temperatures; Heating Thermal Lock-out / Re-start Temperatures):

- System cuts out in heating mode to avoid thermistor error and automatically restarts at these temperatures.

## INDOOR UNIT ACCESSORIES: SLZ-KF15NA

Control Interface	3-Pin Connector	PAC-715AD
	BACnet® and Modbus Interface	PAC-UKPRC001-CN-1
	CN24 Relay Kit	CN24RELAY-KIT-CM3
	Connector and wire for Operation status/error using CN51	PAC-725AD
	Connector cable for remote display	PAC-SA88HA-EP
	IT Extender	PAC-WHS01IE-E
	kumo station® for kumo cloud®	PAC-WHS01HC-E
	Remote Operation Adapter†	PAC-SF40RM-E
	Thermostat Interface	PAC-US444CN-1
	USNAP Adapter	PAC-WHS01UP-E
	Wireless Interface for kumo cloud®	PAC-USWHS002-WF-2
Remote Sensor	Flush Mount Temperature Sensor	PAC-USSEN001-FM-1
	Remote Temperature Sensor	PAC-SE41TS-E
	Wireless temperature and humidity sensor for kumo cloud®	PAC-USWHS003-TH-1
Wired Remote Controller	Deluxe Wired MA Remote Controller†	PAR-40MAAU
	Simple MA Remote Controller†	PAC-YT53CRAU-J
	Touch MA Controller†	PAR-CT01MAU-SB
Wireless Remote Controller	kumo touch™ RedLINK™ Wireless Controller	MHK2
	Wireless MA Receiver	PAR-FA32MA-W
	Wireless Receiver	PAR-SF9FA-E
	Wireless Remote Controller	PAR-SL100A-E
Condensate	Blue Diamond (Advanced) Mini Condensate Pump w/ Reservoir & Sensor (208/230V) [recommended]	X87-721
	Blue Diamond (MicroBlue) Mini Condensate Pump (110/208/230V) up to 18,000 BTU/H	X85-003
	Blue Diamond Alarm Extension Cable—6.5 Ft.	C13-192
	Blue Diamond MultiTank — collection tank for use with multiple pumps	C21-014
	Blue Diamond Sensor Extension Cable — 15 Ft.	C13-103
	Sauermann Condensate Pump	SI30-230
Disconnect Switch	(30A/600V/UL) [fits 2" X 4" utility box] - Black	TAZ-MS303
	(30A/600V/UL) [fits 2" X 4" utility box] - White	TAZ-MS303W
Grille	Grille	SLP-18FAU
i-see Sensor® Panel	3D i-see Sensor® Corner Panel	PAC-SF1ME-E
	Grille with 3D i-see Sensor®	SLP-18FAEU
Lineset	100' x 1/4" x 100' / 1/2" Lineset (Twin-Tube Insulation)	MLS141212T-100
	15' x 1/4" x 15' / 1/2" Lineset (Twin-Tube Insulation)	MLS141212T-15
	30' x 1/4" x 30' / 1/2" Lineset (Twin-Tube Insulation)	MLS141212T-30
	50' x 1/4" x 50' / 1/2" Lineset (Twin-Tube Insulation)	MLS141212T-50
	65' x 1/4" x 65' / 1/2" Lineset (Twin-Tube Insulation)	MLS141212T-65

**NOTES:**

†PAC-SF40RM-E (Unable to use with wireless remote controller)

## OUTDOOR UNIT ACCESSORIES: SUZ-KA15NA2

Control/Service Tool	M- & P-Series Maintenance Tool Cable Set	M21EC0397
	USB/UART Conversion Cable (Required for all laptop connection)	M21EC1397
Hail Guards	Hail Guard	HG-B4
Mini-Split Wire	14 Gauge, 4 wire MiniSplit Cable—250 ft. roll	S144-250
	14 Gauge, 4 wire MiniSplit Cable—250 ft. roll	SW144-250
	14 Gauge, 4 wire MiniSplit Cable—50 ft. roll	S144-50
	14 Gauge, 4 wire MiniSplit Cable—50 ft. roll	SW144-50
	16 Gauge, 4 wire MiniSplit Cable—250 ft. roll	S164-250
	16 Gauge, 4 wire MiniSplit Cable—250 ft. roll	SW164-250
	16 Gauge, 4 wire MiniSplit Cable—50 ft. roll	S164-50
	16 Gauge, 4 wire MiniSplit Cable—50 ft. roll	SW164-50
Mounting Pad	Condensing Unit Mounting Pad: 16" x 36" x 3"	ULTRILITE1
	Outdoor Unit 3-1/4 inch Mounting Base (Pair) - Plastic	DSD-400P
Stand	18" Single Fan Stand	QSMS1801M
	24" Single Fan Stand	QSMS2401M
	Condenser Wall Bracket	QSWB2000M-1
	Outdoor Unit Stand — 12" High	QSMS1201M

# INDOOR UNIT DIMENSIONS: SLZ-KF15NA

Unit: inch (mm)

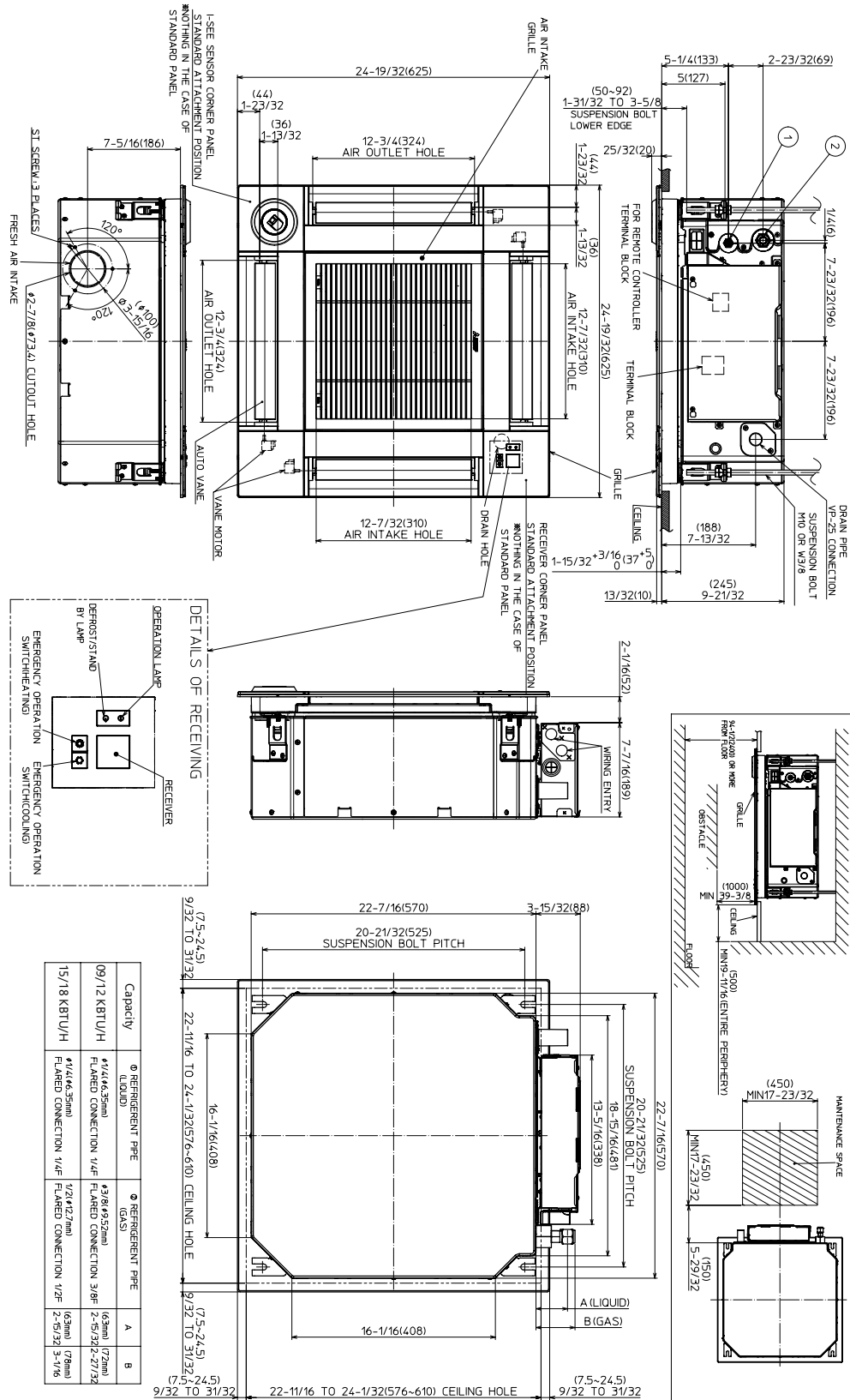

# OUTDOOR UNIT DIMENSIONS: SUZ-KA15NA2

Unit: inch(mm)

## REQUIRED SPACE

\*1 4 in. (100 mm) or more when front and sides of the unit are clear

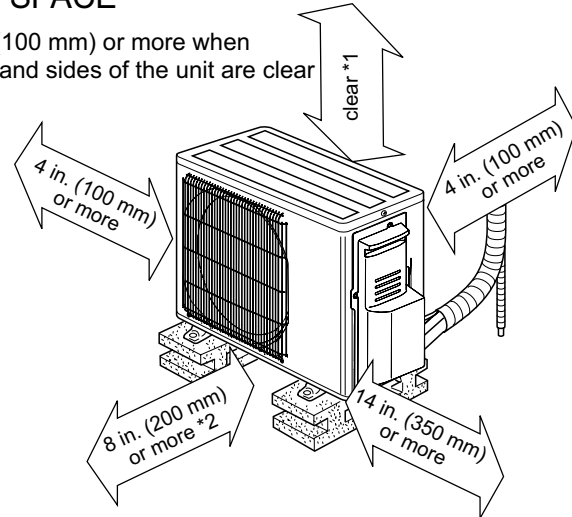

\*2 When any 2 sides of left, right and rear of the unit are clear

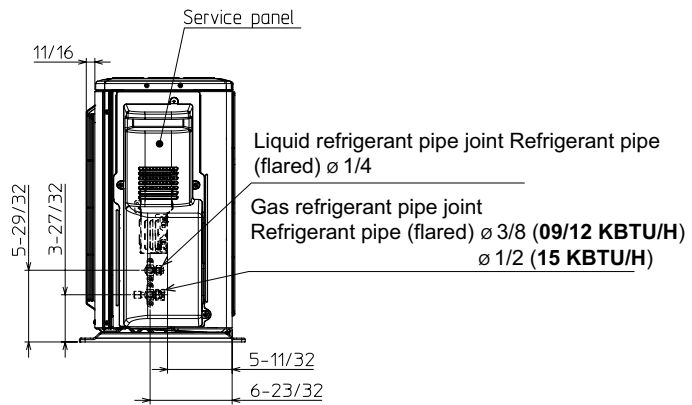
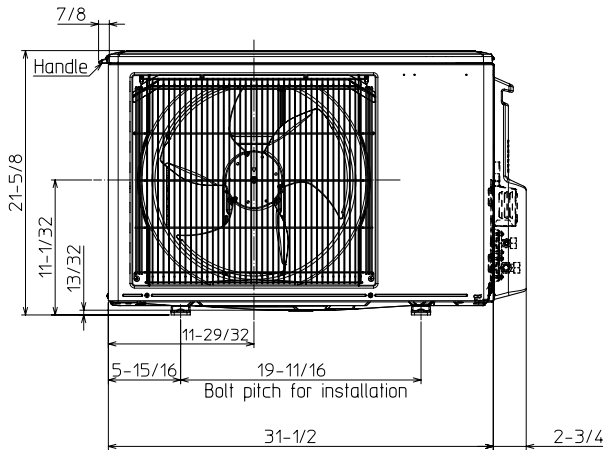
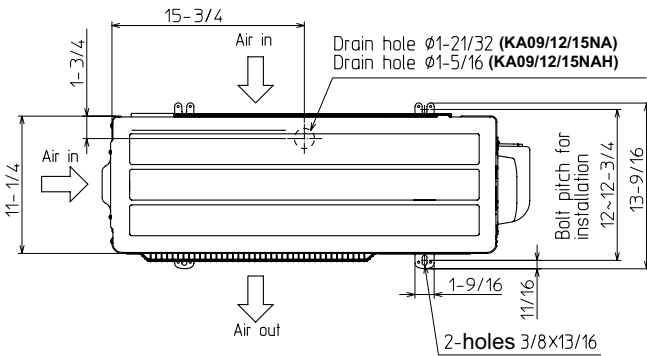

1340 Satellite Boulevard Suwanee, GA 30024  
Toll Free: 800-433-4822 www.mehvac.com

FORM# SLZ-KF15NA.TH & SUZ-KA15NA2.MX - 202106

