

DV-5A Automatic Water Control Valve Deluge Dry Pilot Actuation Fire Protection System 1 1/2 to 8 Inch (DN40 to DN200)

IMPORTANT

Refer to Technical Data Sheet TFP2300 for warnings pertaining to regulatory and health information.

Scan the QR code or enter the URL in a web browser to access the most up-to-date electronic version of this document. Data rates may apply.



docs.jci.com/tycofire/dv-5a-auto-deluge-dry-fire-pro-1-1_2-8-in



General Description

The TYCO DV-5A Automatic Water Control Valve Deluge Dry Pilot Actuation is a diaphragm type valve that can be used in deluge fire protection systems. When properly trimmed, the double seat design of the DV-5A Valve also provides actuation of fire alarms upon system operation.

The diaphragm style design of the DV-5A Valve allows external resetting, providing for easy resetting of a deluge system without having to open a valve handhole cover to manually reposition a clapper and/or latch mechanism. Simply re-pressurizing the diaphragm chamber resets the valve.

The DV-5A features internal and external coating of the valve to provide corrosion resistance. The external corrosion resistance of the epoxy coating permits the use of the DV-5A in corrosive atmospheres associated with many types of industrial processing plants and outdoor installations.

Available End Connections and Weights — lb/(kg)								
End Connection		Nominal Valve Size ANSI Inches (DN)						
Inlet	Outlet	1 1/2 (40)	2 (50)	3 (80)	4 (100)	6 (150)	165,1 mm	8 (200)
Thread	Thread	26 (11,8)	25 (11,3)	N/A	N/A	N/A	N/A	N/A
Groove	Groove	25 (11,3)	25 (11,3)	60 (27,2)	95 (43,1)	177 (80,3)	177 (80,3)	327 (148,3)
Flange	Groove	N/A	N/A	66 (30,0)	106 (48,1)	190 (86,2)	N/A	346 (157,0)
Flange	Flange	N/A	N/A	72 (32,7)	116 (52,6)	204 (92,5)	N/A	365 (165,6)

The DV-5A Deluge Dry Pilot Actuation Valve is offered with the DV-5A Valve and separately ordered semi-assembled trim as shown in Figure 5 for ease of installation.

The DV-5A Deluge Dry Pilot Actuation Valve is offered with or without a System Main Control Valve.

NOTICE

The DV-5A Deluge Dry Pilot Actuation Valve described herein must be installed and maintained in compliance with this document, as well as with the

applicable standards of the NATIONAL FIRE PROTECTION ASSOCIATION (NFPA), in addition to the standards of any other authorities having jurisdiction. Failure to do so may impair the performance of these devices.

The owner is responsible for maintaining their fire protection system and devices in proper operating condition. Contact the installing contractor or product manufacturer with any questions.

Item	Description	Qty.	Nominal Valve Size ANSI Inch (DN)					
			1 1/2 (DN40)	2 (DN50)	3 (DN80)	4 (DN100)	6 (DN150) ^e	8 (DN200)
			P/N	P/N	P/N	P/N	P/N	P/N
1	Valve Body	1	N/R	N/R	N/R	N/R	N/R	N/R
2	Diaphragm	1	545000020	545000020	545000030	545000040	545000060	545000080
3	Diaphragm Cover	1	N/R	N/R	N/R	N/R	N/R	N/R
4	Hex Bolt, Short	2 ^a	545100001	545100001	545100002	545100003	545100004	545100003
5	Hex Bolt, Long	2	545100011	545100011	545100012	545100013	545100014	545100015
6	Lift Washer	2 ^b	N/A	N/A	545100021	545100022	545100023	545100022
7	Hex Nut	2	545100031	545100031	545100032	545100033	545100034	545100033
8	Hoist Ring	2	545100041	545100041	545100041	545100041	545100041	545100041
9	Flat Washer	2	N/A	N/A	545100024	545100025	545100026	545100025

NOTES

- a. Hex Bolt, Short, Qty. 6 in 6 and 8 inch (DN150 and DN200) assemblies.
- b. Lift Washer not used in 1-1/2 and 2 inch (DN40 and DN50) assemblies.
- c. N/R = Not Replaceable

- d. Order replacements parts only via Part Numbers given, do not replace Hex Bolt, Hex Nut, Lift Washer or Hoist Ring with common hardware parts.
- e. Also applicable to metric 165,1 mm size.

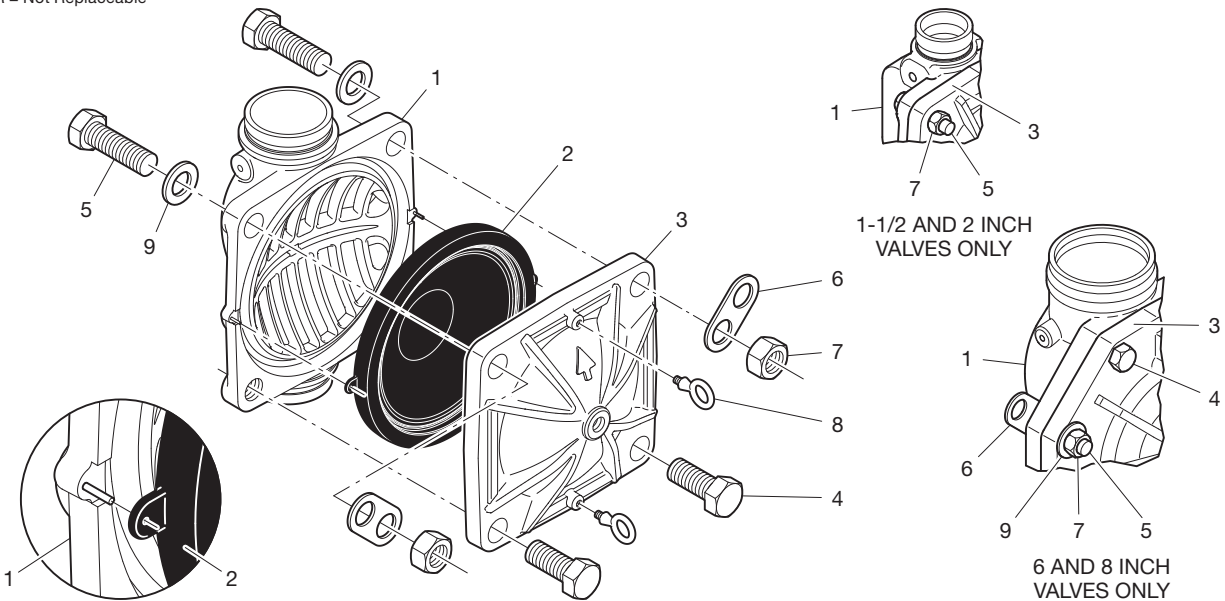
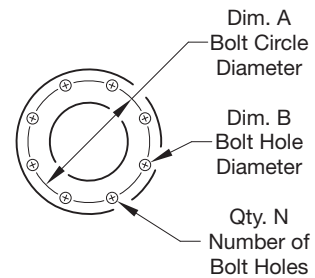

FIGURE 1
DV-5a VALVE ASSEMBLY AND REPLACEMENT PARTS

Nominal Valve Size ANSI Inches (DN)	Flange Drilling Specification											
	Nominal Dimensions in Inches and (mm)											
	ANSI B16.1 ^a (Class 125)			ISO 7005-2 (PN16) ^b			JIS B 2210 (10K)			AS 2129 (Table E)		
	A	B	N	A	B	N	A	B	N	A	B	N
3 (80)	6.00 (152,4)	0.75 (19,0)	4	6.30 (160,0)	0.75 (19,0)	8	5.90 (150,0)	0.59 (15,0)	8	5.75 (146,0)	0.71 (18,0)	4
4 (100)	7.50 (190,5)	0.75 (19,0)	8	7.09 (180,0)	0.75 (19,0)	8	6.89 (175,0)	0.60 (15,0)	8	7.00 (178,0)	0.71 (18,0)	8
6 (150)	9.50 (241,3)	0.88 (22,2)	8	9.45 (240,0)	0.91 (23,0)	8	9.45 (240,0)	0.75 (19,0)	8	9.25 (235,0)	0.87 (22,0)	8
8 (200)	11.75 (298,5)	0.88 (22,2)	8	11.61 (295,0)	0.91 (23,0)	12	11.42 (290,0)	0.75 (19,0)	12	11.50 (292,0)	0.87 (22,0)	8



NOTES

- a. Same drilling as for ANSI B16.5 (Class 150) and ANSI B16.42 (Class 150)
- b. Same drilling as for BS 4504 Section 3.2 (PN16) and DIN 2532 (PN16)

TABLE A
FLANGE DRILLING SPECIFICATIONS

Port	Port Description	Port Sizes, NPT Inch per ANSI B1.20.1					
		1 1/2 (DN40)	2 (DN50)	3 (DN80)	4 (DN100)	6 (DN150) ^a	8 (DN200)
P1	Diaphragm Chamber Supply	1/2	1/2	1/2	1/2	1/2	1/2
P2	Water Supply Pressure & Alarm Test	1/2	1/2	1/2	1/2	1/2	1/2
P3	Alarm Actuation	3/4	3/4	3/4	3/4	3/4	3/4
P4	Automatic Drain Valve	1/2	1/2	1/2	1/2	1/2	1/2
P5	System Drain	3/4	3/4	3/4	3/4	3/4	3/4
P6	Main Drain	3/4	3/4	1-1/4	2	2	2
P7	System Air Supply Not Used for Deluge	1/2	1/2	1/2	1/2	1/2	1/2

NOTES

a. Also applicable to metric 165,1 mm size.

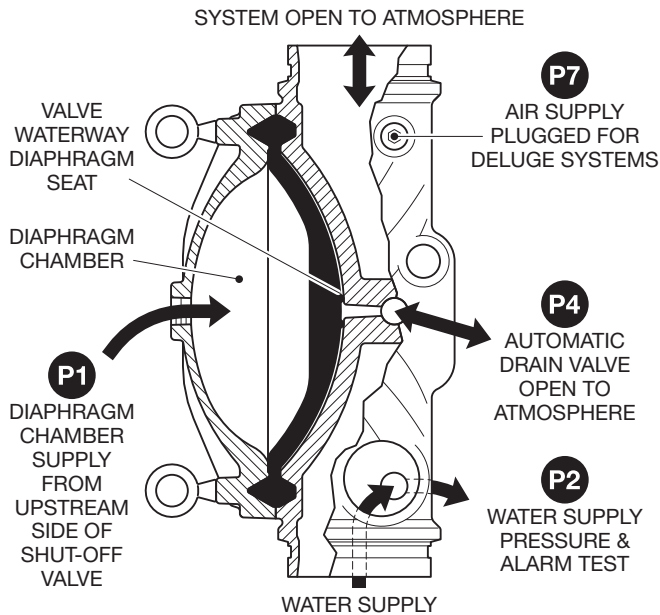

FIGURE 2A
SET CONDITION

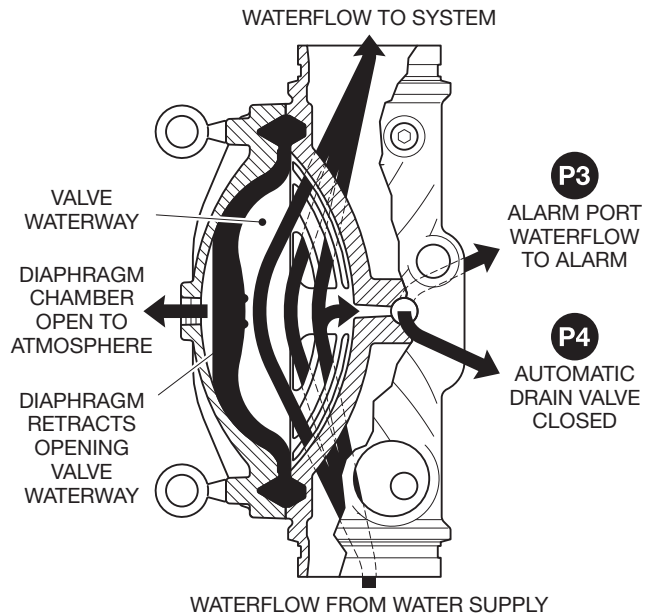

FIGURE 2B
OPERATED CONDITION

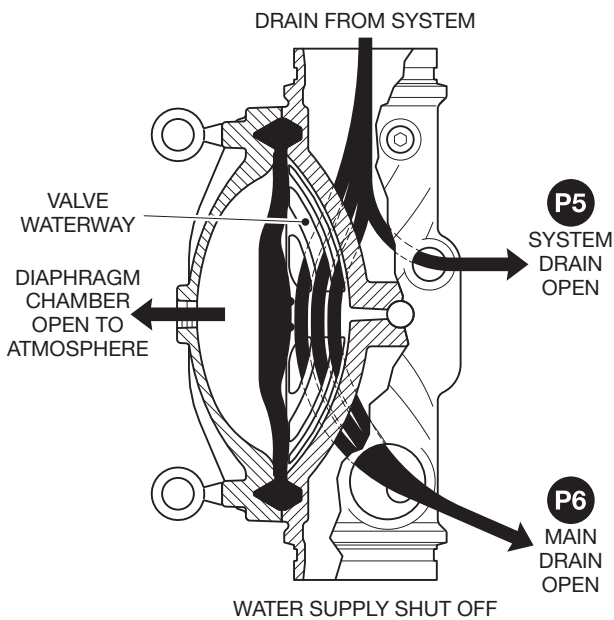

FIGURE 2C
SYSTEM DRAIN CONDITION

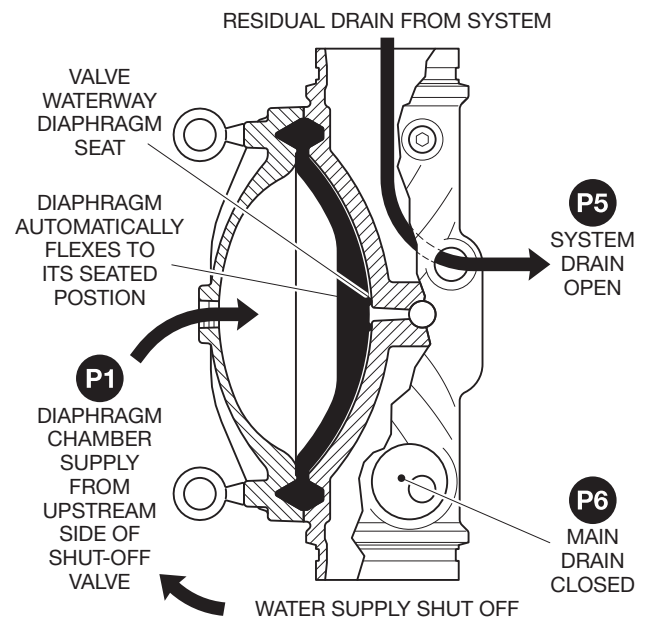
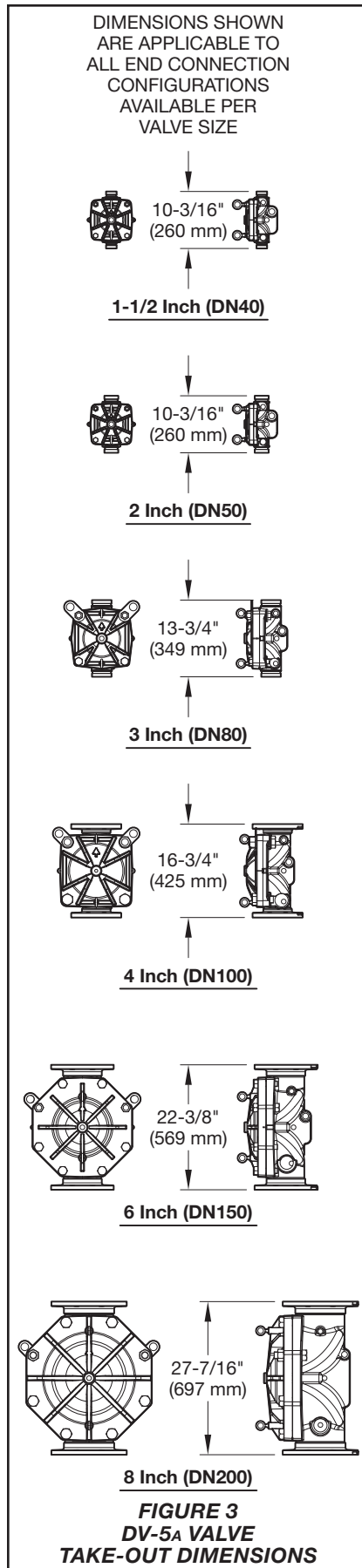

FIGURE 2D
RESIDUAL DRAIN CONDITION

FIGURE 2
DV-5A VALVE OPERATION, DELUGE SYSTEMS



Technical Data

Approvals

UL and C-UL Listed
 FM Approved
 VdS Approved*
 LPCB Approved*
 EAC Approved

Listings and Approvals are based on DV-5A Deluge Dry Pilot Actuation Valve being trimmed as described in Figure 5.

For local EMEA regional approvals, consult with your local distributor.

* VdS and LPCB approval is additionally based on installing the VdS and LPCB required water column prevention drain components provided with assemblies in the Ordering Procedure section.

DV-5A Valve

Components for the 1 1/2 in. to 8 in. (DN40 to DN200) DV-5A Valves are shown in Figure 1. The DV-5A Valves are for vertical installations. They are rated for use at a service pressures of 20 psi to 300 psi (1,4 bar to 20,7 bar).

The take-out dimensions are shown in Figure 3, and the flanged connections are available drilled per ANSI, ISO, AS, and JIS specifications (See Table A). Threaded inlet and port connections are available in NPT or ISO 7-1. Threaded port connections are NPT threaded.

Note: PN16 flanges are pressure rated to 16 bar.

Valve Trim

The maximum pressure rating for the DV-5A Deluge Dry Pilot Actuation Valve is 250 psi (17,2 bar).

When the system pressure is greater than 175 psi (12,1 bar), provision is to be made to replace the standard order 300 psi (20,7 bar) Water Pressure Gauges with separately ordered 600 psi (41,4 bar) Water Pressure Gauges.

If the addition of an Alarm Control Valve is desired or required by the local AHJ, the Alarm Control Valve noted as Item H in Figure 8 is to be a separately ordered electronically supervised normally open valve.

External trim connections are NPT threaded. EMEA trim is provided with NPT x ISO 7-1 thread adapters.

Pressure Loss

See Graph A

Detection System

See Dry Pilot Actuation subsection.

Materials of Construction

Valve Body

Epoxy coated ductile iron per ASTM A536-77, Grade 65-45-12

Diaphragm Cover

Epoxy coated ductile iron per ASTM A536-77, Grade 65-45-12

Diaphragm

Polyester fabric reinforced, TEFLON coated, EPDM rubber per ASTM D2000

Diaphragm Cover Fasteners

Aluminum zinc coated steel

Common Hardware Trim

- Common hardware pipe fittings are galvanized or black as required and are malleable per ASME B16.3.
- Common hardware pipe nipples are galvanized or black as required and are Schedule 40 per ASTM A53 or A135.
- Common hardware compression fittings are brass per ASTM B16.
- Common hardware tubing is Type L copper per ASTM B88.

Operation

The TYCO DV-5A Valve is a diaphragm style valve that depends upon water pressure in the Diaphragm Chamber (See Figure 2A) to hold the Diaphragm closed against the water supply pressure.

When the DV-5A Valve is set for service, the Diaphragm Chamber is pressurized through the trim connections from the inlet side of the system's main control valve.

Opening the Dry Pilot Actuation trips the Model MRA-1 Manual Reset Actuator. Tripping the MRA-1 releases water from the DV-5A Diaphragm Chamber faster than it can be replenished through a 1/8 in. (3,2 mm) restriction located in the diaphragm chamber supply connection. Release of water through the MRA-1 results in a rapid pressure loss in the DV-5A Diaphragm Chamber. The force differential applied through the Diaphragm to hold the Diaphragm in the set position is then reduced below the valve trip point. The water supply pressure then forces the Diaphragm open permitting water to flow into the system piping, as well as through the Alarm Port to actuate the system alarms (See Figure 2B).

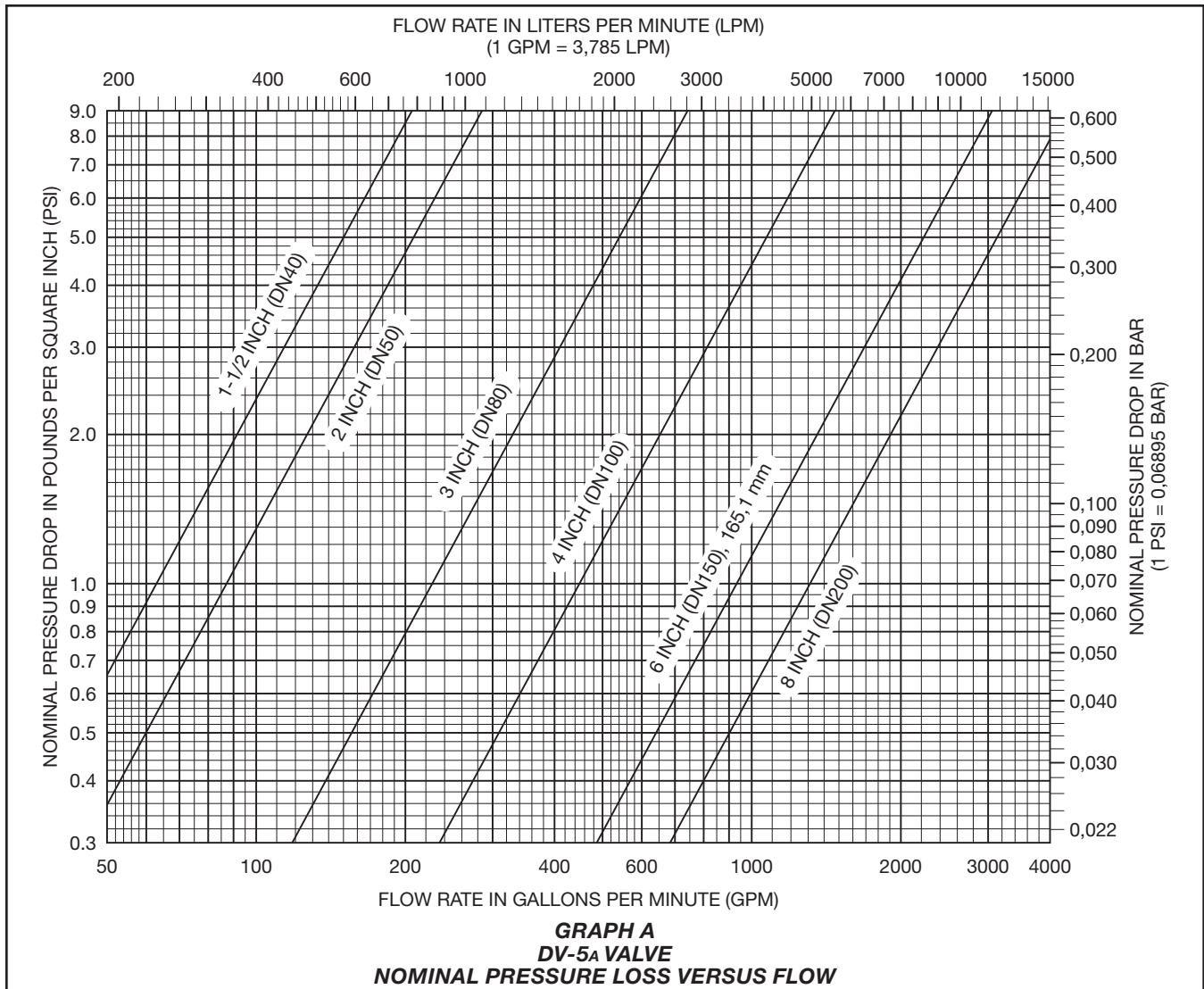

Upon opening of the DV-5A Valve, the Model MRA-1 Manual Reset Actuator, which is described in Technical Data Sheet TFP1387, opens to constantly vent the DV-5A Diaphragm Chamber to hydraulically latch the DV-5A in the tripped position until manually reset.

See the Dry Pilot Actuation section for additional information.

Dry Pilot Actuation

The Dry Pilot Actuation Trim forms a part of the laboratory approval of the DV-5A Valves and is necessary for their proper operation.

With reference to Figure 4, the Dry Pilot Actuation Trim provides for installation of a detection system consisting of pilot sprinklers (heat detectors) and manual control stations interconnected with a minimum length of 56 ft (17,1 m) of 1/2 in. (DN15) steel pipe equivalent to

207 in.³ (3400 cm³). The dry pilot line, which is to be pressurized with air or nitrogen, is connected to the Dry Pilot Line Connection.

Dimensions are provided in Figure 7.

Pilot sprinklers are to be minimum 5.6 K-factor (80 K-factor) orifice approved automatic sprinklers. Manual Control Stations are to be the Model MC-1 described in Technical Data Sheet TFP1382.

Provision must be made for installing a 5.6 K-factor (80 K-factor) Inspector's Test Connection at the most remote location on the dry pilot line.

The Dry Pilot Actuation Trim is provided with a Model DP-1 Dry Pilot Actuator, which is described in Technical Data Sheet TFP1380. The Actuator is rated for use at a maximum pilot service pressure of 50 psi (3,4 bar) and a maximum water supply service pressure of 250 psi (17,2 bar).

Graph B shows the minimum pilot line service pressure as a function of the water supply pressure. The pressure in the dry pilot actuation system must be automatically maintained using one of the following maintenance devices, as appropriate:

- Model AMD-1 Air Maintenance Device (pressure reducing type), refer to Technical Data Sheet TFP1221
- Model AMD-2 Air Maintenance Device (compressor control type), refer to Technical Data Sheet TFP1231
- Model AMD-3 Nitrogen Maintenance Device (high pressure reducing type), refer to Technical Data Sheet TFP1241

Supervision of the pressure in the dry pilot actuation system and an alarm that separately indicates operation of the detection system is provided by a low pressure alarm switch set as follows:

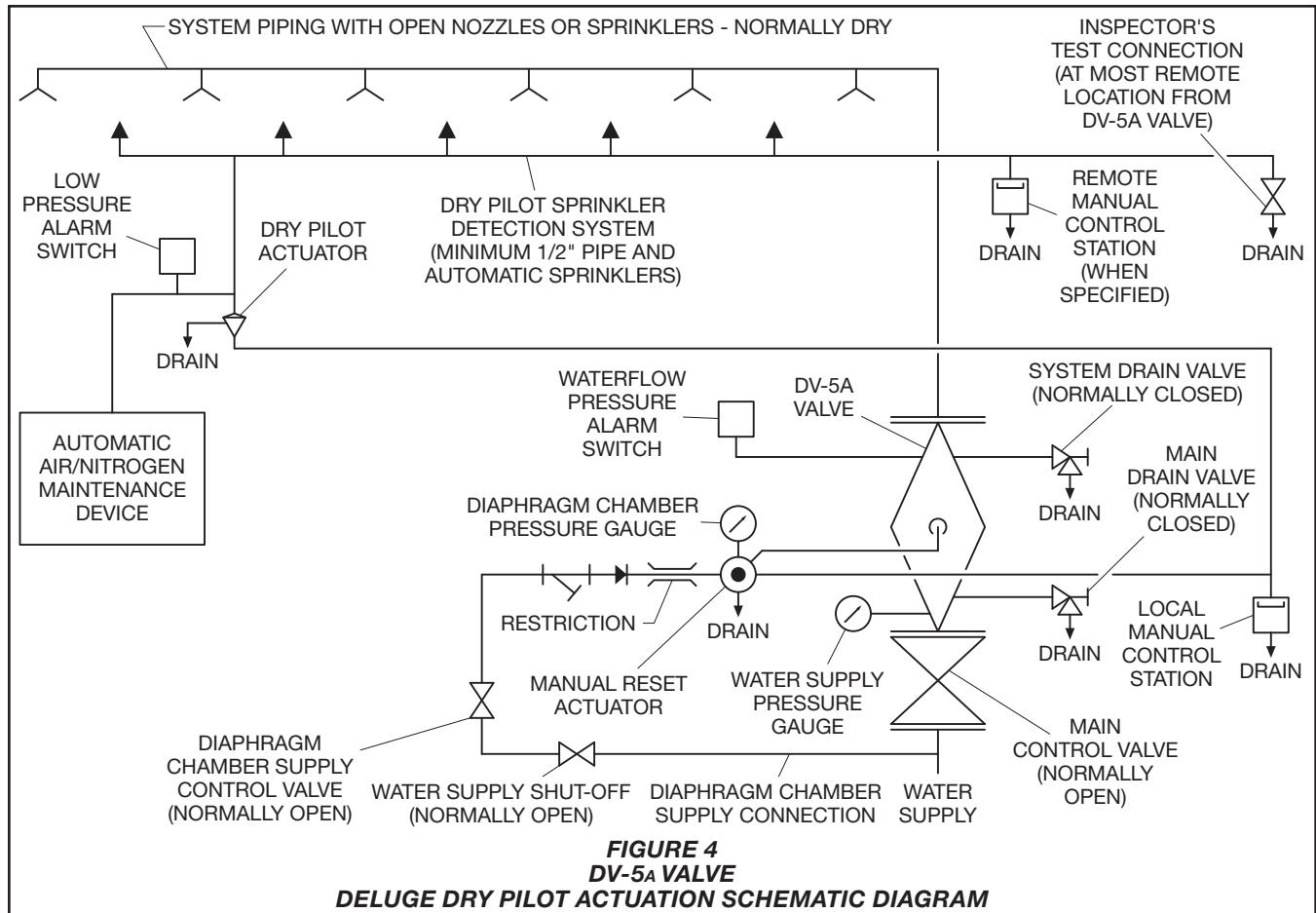

- Low pressure alarm setting at approximately 6 psi (0,4 bar) below the minimum pilot line service pressure requirement shown in Graph B
- Fire alarm setting at approximately 15 psi (1,0 bar) below the minimum pilot line service pressure requirement shown in Graph B

The Pressure Relief Valve provided in the trim is factory set to relieve at a pressure of approximately 45 psi (3,1 bar); however, it may be field adjusted to a lower pressure, if required.

The dry pilot line is to be provided with low point drains to enable draining of condensate.

Note: At a minimum, it is recommended that internally galvanized pipe and cast iron fittings be used for dry pilot lines.

Installation

The TYCO DV-5A Automatic Water Control Valve Dry Pilot Actuation is to be installed in accordance with this section.

NOTICE

DV-5A Automatic Water Control Valves are designed to be used in freshwater systems. When the supply is from an alternative source such as brackish water, saltwater, or contains additives such as foam, the limited warranty is reduced to one year from the time of installation. An increase in frequency of inspections is required when the valve is exposed to such supplies and other corrosive conditions or chemicals that could impact valve materials or the operation of the assembly. The system and all components must be designed accordingly for the increased demand. It is required to thoroughly flush the valve and trim assembly with freshwater and reset to the set condition after each operation.

Proper operation of the DV-5A Valves depends upon their trim being installed in accordance with the instructions given in this technical data sheet. Failure to follow the appropriate trim diagram may prevent the DV-5A Valve from functioning properly, as well as void approvals and the manufacturer's warranties.

The DV-5A Automatic Water Control Valve Dry Pilot must be installed in a readily visible and accessible location.

Heat tracing of the DV-5A Valve or its associated trim is not permitted. Heat tracing can result in the formation of hardened mineral deposits that are capable of preventing proper operation.

Always open the system control valves slowly to avoid a sudden rush of water entering the system.

The DV-5A Valve is to be installed in accordance with the following criteria:

Step 1. All nipples, fittings, and devices must be clean and free of scale and burrs before installation. Use pipe thread sealant sparingly on male pipe threads only.

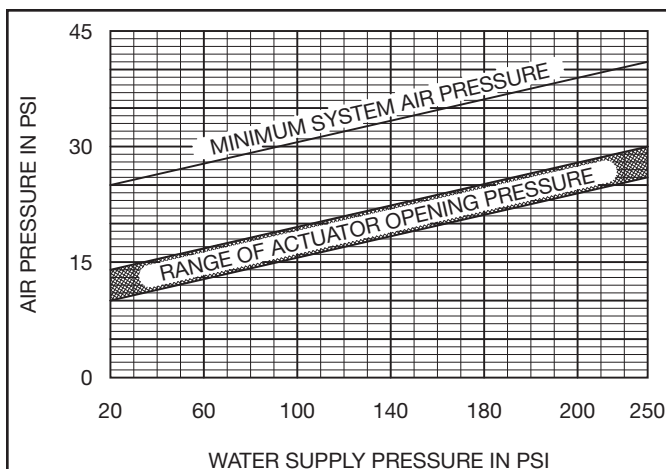

NOTES:

The dew point of the pilot line air pressure must be maintained below the lowest ambient temperature to which the dry pilot actuation system will be exposed. Accumulation of water in the pilot line connection to the Actuator will lower the air pressure at which the actuator will open and possibly prevent proper operation. Also, introduction of moisture into the pilot lines exposed to freezing temperatures can create an ice buildup that could prevent proper operation of the Actuator.

An air dryer must be installed where the moisture content of the air supply is not properly controlled at less than the required value.

It is recommended that an AMD-3 Nitrogen Maintenance Device be utilized in dry pilot actuation system applications where the dew point must be maintained below -20°F (-29°C). Refer to Technical Data Sheet TFP1241.

**GRAPH B
DV-5A VALVE
DRY PILOT LINE AIR PRESSURE REQUIREMENTS**

Step 2. The DV-5A Valve must be trimmed in accordance with the Dry Pilot Actuation trim illustration as shown in Figure 5.

Note: If the addition of an Alarm Control Valve is desired or required by the local AHJ, the Alarm Control Valve noted as Item H in Figure 8 is to be a separately ordered electronically supervised normally open valve.

Step 3. Care must be taken to ensure that check valves, strainers, globe valves, etc. are installed with the flow arrows in the proper direction.

Step 4. Drain tubing to the Drip Funnel must be installed with smooth bends that will not restrict flow.

Step 5. The Main Drain and Drip Funnel Drain may be interconnected provided a check valve is located at least 12 in. (300 mm) below the Drip Funnel.

Step 6. Suitable provision must be made for disposal of drain water. Drainage water must be directed such that it will not cause accidental damage to property or danger to persons.

Step 7. Connect the Diaphragm Supply Valve to the inlet side of the System Main Control Valve in order to facilitate setting of the DV-5A Valve. See Figure 8.

Step 8. An Inspector's Test Connection, as described in the Dry Pilot Actuation section, must be provided for Dry Pilot Actuation systems.

Step 9. An Air Maintenance Device, as described in the Dry Pilot Actuation section, must be provided for Dry Pilot Actuation.

Step 10. A desiccant dryer, when specified for Dry Pilot Actuation, is to be installed between a drip leg and the Air Maintenance Device.

Step 11. The Low Pressure Alarm Switch for Dry Pilot Actuation is to be adjusted as follows:

- Low pressure alarm setting at approximately 6 psi (0,4 bar) below the minimum pilot line service pressure requirement shown in Graph B
- Fire alarm setting at approximately 15 psi (1,0 bar) below the minimum pilot line service pressure requirement shown in Graph B

Step 12. Unused Pressure Alarm Switch connections must be plugged.

Step 13. The Pressure Relief Valve provided with the Dry Pilot Actuation Trim is factory set to relieve at a pressure of approximately 45 psi (3,1 bar), which can typically be used for a maximum dry pilot actuation system pressure of 40 psi (2,8 bar). The Pressure Relief Valve may be reset; however, it must be reset to relieve at a pressure which is in accordance with the requirements of the authority having jurisdiction.

To reset the Pressure Relief Valve, first loosen the jam nut and then adjust the

cap accordingly, clockwise for a higher pressure setting or counter clockwise for a lower pressure setting. After verifying the desired pressure setting, tighten the jam nut.

Step 14. Conduit and electrical connections are to be made in accordance with the applicable standards of the approval agency.

Step 15. Before a system hydrostatic test is performed, the DV-5A Diaphragm Chamber is to be depressurized, the Automatic Drain Valve is to be temporarily replaced with a plug, and the Diaphragm Cover Bolts must be uniformly and securely tightened using a cross-draw sequence. After tightening, double-check to make certain that all of the Diaphragm Cover Bolts are securely tightened. See Table B in the Care and Maintenance section for torque specifications.

Valve Setting Procedure

Perform Steps 1 through 13 when initially setting the TYCO DV-5A Valve, after an operational test of the fire protection system, or after system operation due to a fire. See Figure 8.

Step 1. Close the System Main Control Valve (B).

Step 2. Close the Diaphragm Supply Valve (P). For Dry Pilot Actuation, close the Dry Pilot Air Supply Valve (U).

Step 3. Open the Main Drain Valve (D), System Drain Valve (E), and all auxiliary drains in the system. Close the auxiliary drain valves and the System Drain Valve (E) after water ceases to discharge. Leave the Main Drain Valve (D) open.

At this time make certain that the Pressure Gauge Valves and the Alarm Control Valve (H), as applicable, are open.

Step 4. Depress the plunger of the Automatic Drain Valve (F) to verify that it is open.

Step 5. Clean the Diaphragm Supply Strainer (Q) by removing the clean-out plug and strainer basket. The Diaphragm Supply Strainer (Q) may be flushed out by momentarily opening the Diaphragm Supply Valve (P).

Step 6. Reset the automatic Dry Pilot Actuation by replacing operated pilot sprinklers and/or reset the remote manual control stations. Re-establish dry pilot pneumatic pressure.

NOTICE

In order to prevent the possibility of a subsequent operation of an overheated solder type pilot sprinkler, any solder type pilot sprinklers that were possibly exposed to a temperature greater than their maximum rated ambient must be replaced.

Step 7. Operate (open) the Manual Control Station (M) and then open the Diaphragm Supply Valve (P). After unaerated water ceases to discharge from the Manual Control Station (M) drain tube, slowly close the operating lever by pushing it up. Do not close the hinged cover at this time.

Step 8. After allowing water to flow out of the Manual Reset Actuator (N) drain tube until aerated water ceases to discharge, reset the Manual Reset Actuator (N) by pressing the Reset Knob and hold until water stops flowing from its drain tube and the pressure builds and reaches approximately 15 psi (1,0 bar) on the Diaphragm Gauge (K). Pressure will then build up in the DV-5A Diaphragm Chamber.

Note: *After relieving trapped air, check the Manual Reset Actuator (N) to make sure there is no water draining from its drain tube. If water is draining, reset the Manual Reset Actuator (N) as previously instructed.*

Step 9. Verify the ability for the DV-5A Diaphragm to hold pressure as follows:

- With the diaphragm chamber pressurized per Step 8, temporarily close the Diaphragm Supply Valve (P), and then observe the Diaphragm Gauge (K) for a drop in pressure.
- If a drop in pressure is noted, the DV-5A Diaphragm is to be replaced and/or any leaks must be corrected before proceeding to the next step.
- If the Diaphragm Gauge (K) indicates no drop in pressure, re-open the Diaphragm Supply Valve (P) and proceed to the next step.

Step 10. Partially open the System Main Control Valve (B). Slowly close the Main Drain Valve (D) as soon as water discharges from the Main Drain Valve (D). Observe the Automatic Drain Valve (F) for leaks. If there are leaks, determine/correct the cause of the leakage problem before proceeding.

NOTICE

When the System Main Control Valve (B) is partially opened, the pressure on the DV-5A Diaphragm Chamber may increase. This increase in pressure is normal, and if the pressure is greater than the valve trim maximum pressure rating provided in the Technical Data section, the pressure is to be relieved to at least the valve trim pressure rating by partially and temporarily opening the Manual Control Station (M); however, do not allow the pressure as indicated on the Diaphragm Gauge (K) to drop below the supply pressure shown on the Water Supply Gauge (J), since this action may result in tripping of the DV-5A Valve.

Step 11. Close the hinged cover of the Manual Control Station (M), and insert a new break rod in the small hole through the top of the enclosing box.

Step 12. Fully open the System Main Control Valve (B).

Step 13. After setting a fire protection system, notify the proper authorities and advise those responsible for monitoring proprietary and/or central station alarms.

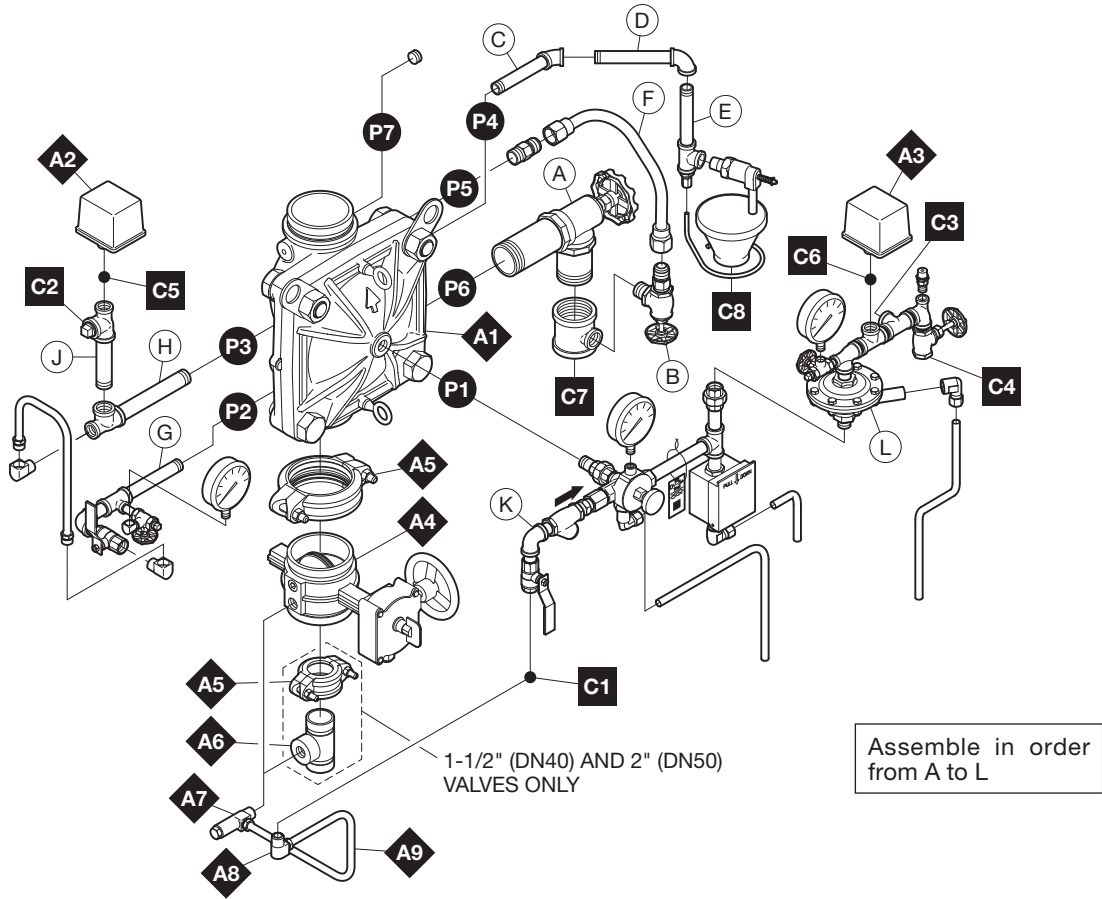

Assemble in order
from A to L

NOTES

1. Port Connections P1 through P7 are described in Figure 2.
2. External Trim Connections C1 through C8 are described in Figure 8.
3. When ordering pre-assembled "DV-5A Valve with Galvanized Trim" or pre-assembled "DV-5A Valve with Galvanized Trim and Butterfly Valve", Items A1 through A9 are provided, as applicably related to valve size.
4. When ordering DV-5A Trim separately from the DV-5A Valve, Items A1 through A9 are separately ordered, as applicably related to valve size. Water Pressure Gauges for EMEA valve trim are also separately ordered.

FIGURE 5
DV-5A VALVE
DELUGE DRY PILOT ACTUATION TRIM
SEMI-ASSEMBLED

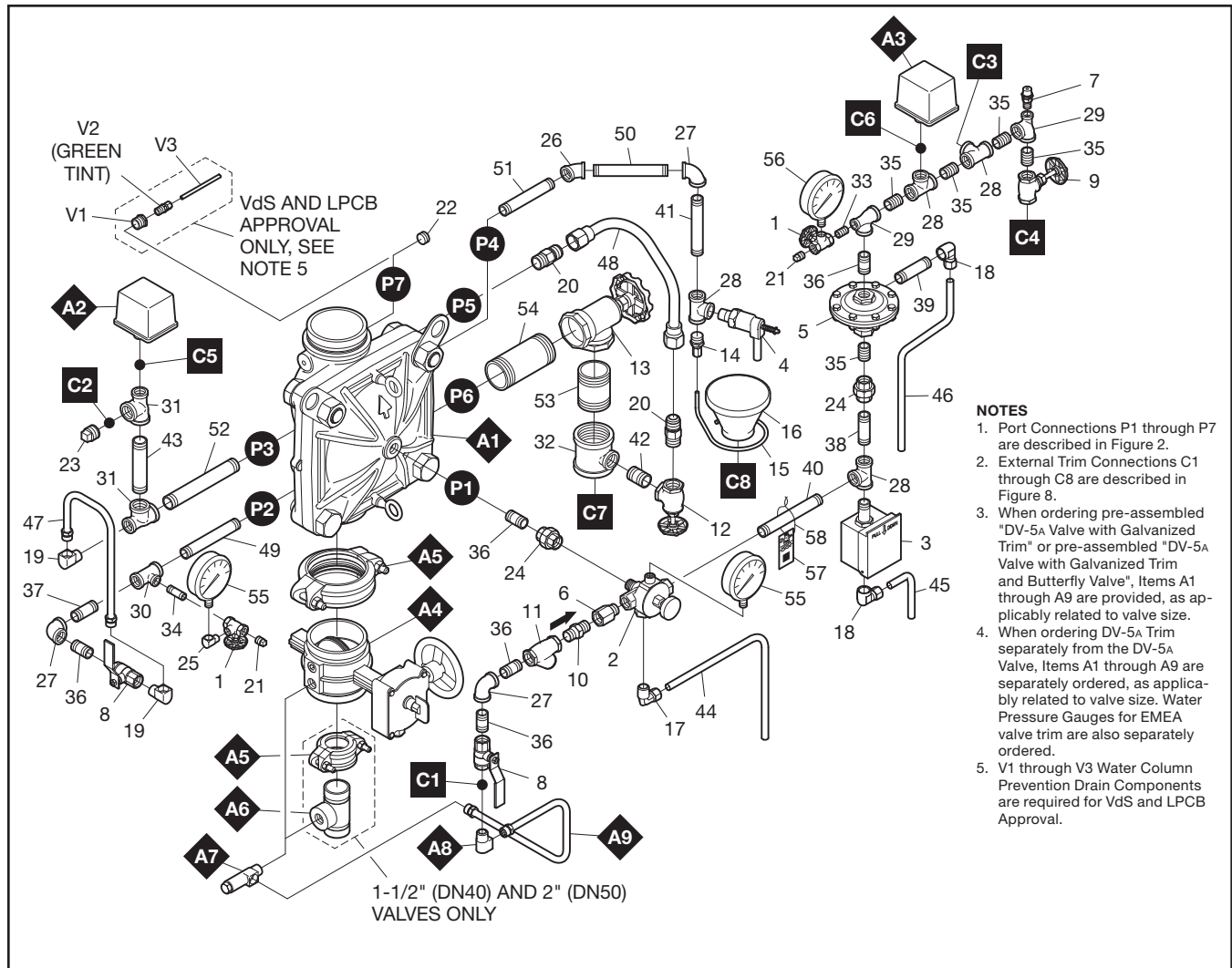

- NOTES**
1. Port Connections P1 through P7 are described in Figure 2.
 2. External Trim Connections C1 through C8 are described in Figure 8.
 3. When ordering pre-assembled "DV-5A Valve with Galvanized Trim" or pre-assembled "DV-5A Valve with Galvanized Trim and Butterfly Valve", Items A1 through A9 are provided, as applicably related to valve size.
 4. When ordering DV-5A Trim separately from the DV-5A Valve, Items A1 through A9 are separately ordered, as applicably related to valve size. Water Pressure Gauges for EMEA valve trim are also separately ordered.
 5. V1 through V3 Water Column Prevention Drain Components are required for VdS and LPCB Approval.

ITEM	QTY.	DESCRIPTION	CH	1 1/2 IN. (DN40)	2 IN. (DN50)	3 IN. (DN80)	4 IN. (DN100)	6 IN. (DN150) ⁸	8 IN. (DN200)
1	2	1/4" GAUGE TEST VALVE		460051003	460051003	460051003	460051003	460051003	460051003
2	1	MRA-1 MANUAL RESET ACTUATOR		545001000	545001000	545001000	545001000	545001000	545001000
3	1	MC-2 MANUAL CONTROL STATION		545002000	545002000	545002000	545002000	545002000	545002000
4	1	AD-3 AUTOMATIC DRAIN VALVE		547932004	547932004	547932004	547932004	547932004	547932004
5	1	DP-1 DRY PILOT ACTUATOR		522801001	522801001	522801001	522801001	522801001	522801001
6	1	PRIMING SUPPLY RESTRICTION		545100051	545100051	545100051	545100051	545100051	545100051
7	1	1/4" PRESSURE RELIEF VALVE		923431020	923431020	923431020	923431020	923431020	923431020
8	2	1/2" BALL VALVE		460501004	460501004	460501004	460501004	460501004	460501004
9	1	1/2" GLOBE VALVE		460471005	460471005	460471005	460471005	460471005	460471005
10	1	1/2" SPRING LOADED CHECK VALVE		923221003	923221003	923221003	923221003	923221003	923221003
11	1	1/2" Y-STRAINER		523531006	523531006	523531006	523531006	523531006	523531006
12	1	3/4" ANGLE VALVE		460481010	460481010	460481010	460481010	460481010	460481010
13	1	ANGLE VALVE		460481010	460481010	460481011	460481012	460481012	460481012
14	1	DRIP FUNNEL BRACKET CONNECTOR		922111005	922111005	922111005	922111005	922111005	922111005
15	1	DRIP FUNNEL BRACKET		922111003	922111003	922111003	922111003	922111003	922111003
16	1	DRIP FUNNEL		923431007	923431007	923431007	923431007	923431007	923431007
17	1	COMP. FITTING 90° 1/2" MNPT x 1/2" OD TUBE	✓	—	—	—	—	—	—
18	2	COMP. FITTING 90° 1/2" FNPT x 1/2" OD TUBE	✓	—	—	—	—	—	—
19	2	FLARE FITTING 90° 1/2" NPT x 1/2" TUBE		545100062	545100062	545100062	545100062	545100062	545100062
20	2	FLARE FITTING 3/4" NPT x 3/4" TUBE		545100063	545100063	545100063	545100063	545100063	545100063
21	2	PIPE PLUG	✓	1/4"	1/4"	1/4"	1/4"	1/4"	1/4"
22	1	PIPE PLUG, SOCKET HEAD	✓	1/2"	1/2"	1/2"	1/2"	1/2"	1/2"
23	1	PIPE PLUG	✓	3/4"	3/4"	3/4"	3/4"	3/4"	3/4"
24	2	UNION	✓	1/2"	1/2"	1/2"	1/2"	1/2"	1/2"
25	1	STREET ELBOW	✓	1/4" x 90°	1/4" x 90°	1/4" x 90°	1/4" x 90°	1/4" x 90°	1/4" x 90°

FIGURE 6 (1 OF 2)
DV-5A VALVES – DELUGE DRY PILOT ACTUATION TRIM – EXPLODED VIEW

ITEM	QTY.	DESCRIPTION	CH	1 1/2 IN. (DN40)	2 IN. (DN50)	3 IN. (DN80)	4 IN. (DN100)	6 IN. (DN150) ^b	8 IN. (DN200)
26	1	ELBOW	✓	1/2" x 45°	1/2" x 45°	1/2" x 45°	1/2" x 45°	1/2" x 45°	1/2" x 45°
27	3	ELBOW	✓	1/2" x 90°	1/2" x 90°	1/2" x 90°	1/2" x 90°	1/2" x 90°	1/2" x 90°
28	4	TEE	✓	1/2"	1/2"	1/2"	1/2"	1/2"	1/2"
29	2	REDUCING TEE	✓	1/2" x 1/4" x 1/2"	1/2" x 1/4" x 1/2"	1/2" x 1/4" x 1/2"	1/2" x 1/4" x 1/2"	1/2" x 1/4" x 1/2"	1/2" x 1/4" x 1/2"
30	1	REDUCING TEE	✓	1/2" x 1/2" x 1/4"	1/2" x 1/2" x 1/4"	1/2" x 1/2" x 1/4"	1/2" x 1/2" x 1/4"	1/2" x 1/2" x 1/4"	1/2" x 1/2" x 1/4"
31	2	REDUCING TEE	✓	3/4" x 1/2" x 3/4"	3/4" x 1/2" x 3/4"	3/4" x 1/2" x 3/4"	3/4" x 1/2" x 3/4"	3/4" x 1/2" x 3/4"	3/4" x 1/2" x 3/4"
32	1	REDUCING TEE	✓	3/4" x 3/4" x 3/4"	3/4" x 3/4" x 3/4"	1-1/4" x 1-1/4" x 3/4"	2" x 2" x 3/4"	2" x 2" x 3/4"	2" x 2" x 3/4"
33	1	PIPE NIPPLE	✓	1/4" x CLOSE	1/4" x CLOSE	1/4" x CLOSE	1/4" x CLOSE	1/4" x CLOSE	1/4" x CLOSE
34	1	PIPE NIPPLE	✓	1/4" x 1 1/2"	1/4" x 1 1/2"	1/4" x 1 1/2"	1/4" x 1 1/2"	1/4" x 1 1/2"	1/4" x 1 1/2"
35	5	PIPE NIPPLE	✓	1/2" x CLOSE	1/2" x CLOSE	1/2" x CLOSE	1/2" x CLOSE	1/2" x CLOSE	1/2" x CLOSE
36	5	PIPE NIPPLE	✓	1/2" x 1 1/2"	1/2" x 1 1/2"	1/2" x 1 1/2"	1/2" x 1 1/2"	1/2" x 1 1/2"	1/2" x 1 1/2"
37	1	PIPE NIPPLE	✓	1/2" x 2"	1/2" x 2"	1/2" x 2"	1/2" x 2"	1/2" x 2"	1/2" x 2"
38	1	PIPE NIPPLE	✓	1/2" x 2 1/2"	1/2" x 2 1/2"	1/2" x 2 1/2"	1/2" x 2 1/2"	1/2" x 2 1/2"	1/2" x 2 1/2"
39	1	PIPE NIPPLE	✓	1/2" x 3"	1/2" x 3"	1/2" x 3"	1/2" x 3"	1/2" x 3"	1/2" x 3"
40	1	PIPE NIPPLE	✓	1/2" x 4 1/2"	1/2" x 4 1/2"	1/2" x 4 1/2"	1/2" x 4 1/2"	1/2" x 4 1/2"	1/2" x 4 1/2"
41	1	PIPE NIPPLE	✓	1/2" x 5"	1/2" x 5"	1/2" x 5"	1/2" x 5"	1/2" x 5"	1/2" x 5"
42	1	PIPE NIPPLE	✓	3/4" x 1 1/2"	3/4" x 1 1/2"	3/4" x 1 1/2"	3/4" x 1 1/2"	3/4" x 1 1/2"	3/4" x 1 1/2"
43	1	PIPE NIPPLE	✓	3/4" x 4 1/2"	3/4" x 4 1/2"	3/4" x 4 1/2"	3/4" x 4 1/2"	3/4" x 4 1/2"	3/4" x 4 1/2"
44	1	TUBING, MRA-1 DRAIN		545100065	545100065	545100066	535002140	535002160	535002180
45	1	TUBING, MC-2 DRAIN		535000220	535000220	535000230	535000240	535000260	535000280
46	1	TUBING, DP-1 DRAIN		535000520	535000520	535000530	535000540	535000560	535000580
47	1	TUBING ASSY, ALARM TEST INTERCONNECT		535000320	535000320	535000330	535000340	535000360	535000380
48	1	TUBING ASSY, SYSTEM DRAIN		535000420	535000420	535000430	535000440	535000460	535000480
49	1	PIPE NIPPLE	✓	1/2" x 3 1/2"	1/2" x 3 1/2"	1/2" x 4 1/2"	1/2" x 5 1/2"	1/2" x 5 1/2"	1/2" x 6 3/4"
50	1	PIPE NIPPLE	✓	1/2" x 5"	1/2" x 5"	1/2" x 5 1/2"	1/2" x 5 1/2"	1/2" x 5 1/2"	1/2" x 6 1/2"
51	1	PIPE NIPPLE	✓	1/2" x 5"	1/2" x 5"	1/2" x 4 1/2"	1/2" x 5"	1/2" x 7 1/2"	1/2" x 9 1/2"
52	1	PIPE NIPPLE	✓	3/4" x 5"	3/4" x 5"	3/4" x 6"	3/4" x 7"	3/4" x 9"	3/4" x 11-1/2"
53	1	PIPE NIPPLE	✓	3/4" x 4 1/2"	3/4" x 4 1/2"	1 1/4" x 3 1/4"	2" x 3"	2" x 3"	2" x 3"
54	1	PIPE NIPPLE	✓	3/4" x 6 1/2"	3/4" x 6 1/2"	1 1/4" x 5 1/2"	2" x 5"	2" x 6"	2" x 8"
55	2	WATER PRESSURE GAUGE, 300 PSI / 2000 kPa (AMER/APAC)		923431005	923431005	923431005	923431005	923431005	923431005
	2	WATER PRESSURE GAUGE, 20 bar / 2000 kPa (EMEA)		025500013	025500013	025500013	025500013	025500013	025500013
56	1	AIR PRESSURE GAUGE, 80 PSI / 550 kPa RETARDED TO 250PSI / 1750 kPa		923431012	923431012	923431012	923431012	923431012	923431012
57	1	LABEL		545003001	545003001	545003001	545003001	545003001	545003001
58	1	LABEL WIRE		—	—	—	—	—	—
A1	1	DV-5A Valve		SEE ORDERING PROCEDURE, SEPARATE DV-5A VALVES WITHOUT TRIM, FOR PART NUMBERS.					
A2	1	WATERFLOW PRESSURE ALARM SWITCH, PS10-2 (AMER/APAC)		25710	25710	25710	25710	25710	25710
	1	WATERFLOW PRESSURE ALARM SWITCH, PS10-1 (EMEA)		0260	0260	0260	0260	0260	0260
A3	1	LOW AIR PRESSURE ALARM SWITCH, PS40-2 (AMER/APAC)		25730	25730	25730	25730	25730	25730
	1	LOW AIR PRESSURE ALARM SWITCH, PS40-1 (EMEA)		0262	0262	0262	0262	0262	0262
A4	1	BUTTERFLY VALVE, G x G		51024A	51021A	—	—	—	—
	1	BFV-300 BUTTERFLY VALVE, G x G		—	—	59300G030WS	59300G040WS	59300G060WS	59300G080WS
A5	2	FIGURE 577 RIGID GROOVED COUPLING		57715ACP	57720ACP	—	—	—	—
	1	FIGURE 577 RIGID GROOVED COUPLING		—	—	57730ACP	57740ACP	57760ACP	57780ACP
A6	1	GROOVE x THREADED OUTLET WELDED TEE		545004000	545004001	—	—	—	—
A7	1	INVERTED FLARE SHUT-OFF VALVE ^a		545100100	545100100	545100099	545100100	545100100	545100100
A8	1	FLARE FITTING 90° 1/2" NPT x 1/2" TUBE		545100062	545100062	545100062	545100062	545100062	545100062
A9	1	TUBING ASSY, DIAPHRAGM CHAMBER SUPPLY		540000015	540000020	540000030	540000040	540000060	540000080
V1	1	REDUCING BUSHING	✓	1/2" x 1/4"	1/2" x 1/4"	1/2" x 1/4"	1/2" x 1/4"	1/2" x 1/4"	1/2" x 1/4"
V2	1	3/32" VENT FITTING		920321002	920321002	920321002	920321002	920321002	920321002
V3	1	TUBING, VENT TRIM DRAIN		923041035	923041035	923041035	923041035	923041035	923041035

NOTES

- a. Not VdS Approved
- b. Also applicable to metric 165,1 mm size.
- CH - Common Hardware - Refer to Materials of Construction section for specifications.

FIGURE 6 (2 OF 2)
DV-5A VALVES – DELUGE DRY PILOT ACTUATION TRIM – EXPLODED VIEW

Nominal Valve Size ANSI Inches (DN)	Inches (mm)								
	A	B	C	D	E	F	G	H	J
1 1/2 (40)	2.8 (71)	9.7 (246)	10.4 (264)	16.5 (419)	19.3 (490)	7.3 (185)	10.2 (259)	8.02 (204)	1.2 (31)
2 (50)	2.8 (71)	9.7 (246)	10.4 (264)	16.5 (419)	19.3 (490)	7.3 (185)	10.2 (259)	8.09 (205)	2.9 (74)
3 (80)	3.0 (76)	11.4 (290)	12.0 (305)	16.5 (419)	21.2 (539)	5.8 (147)	13.8 (351)	3.79 (96)	3.6 (91)
4 (100)	3.0 (76)	12.7 (323)	13.1 (333)	16.5 (419)	22.7 (577)	5.1 (130)	16.8 (427)	4.54 (115)	4.3 (109)
6 ³ (150)	4.5 (114)	14.0 (356)	15.0 (381)	16.5 (419)	25.4 (645)	3.4 (86)	22.4 (569)	5.83 (148)	5.7 (145)
8 (200)	5.3 (135)	16.8 (427)	17.2 (437)	19.5 (495)	28.0 (711)	2.9 (74)	27.5 (699)	5.24 (133)	6.7 (170)

- NOTES**
1. Dimensions based on drain valves being open.
 2. Dimensions do not provide installation clearance.
 3. Also applicable to metric 165,1 mm size.

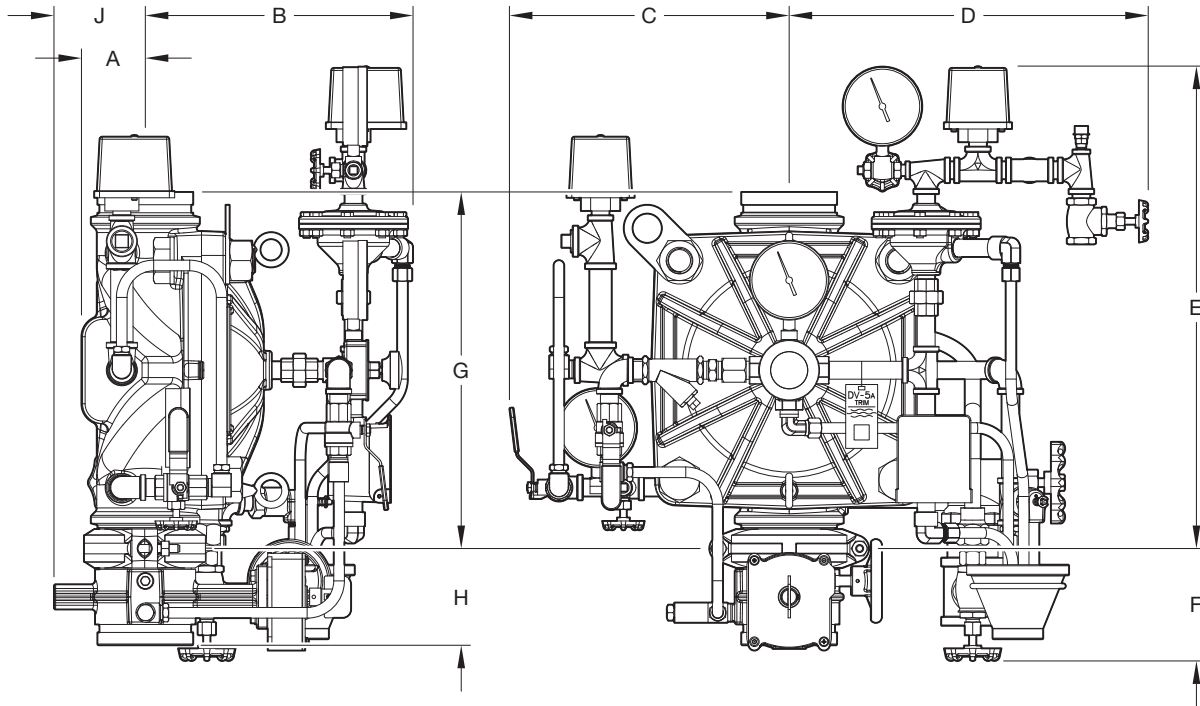

FIGURE 7
DV-5A VALVE
DELUGE DRY PILOT ACTUATION TRIM ASSEMBLY
NOMINAL DIMENSIONS

Care and Maintenance

The following procedures and inspections must be performed as indicated, in addition to any specific requirements of the NFPA and any applicable standards recognized by the Approval agency. Any impairment must be immediately corrected. See Figure 8.

NOTICE

If the water supply needs to be shut off to the DV-5A valve and trim and cannot be shut off upstream of the system, close the System Main Control Valve (B), the Diaphragm Supply Valve (P), and the Inverted Flare Shut-Off Valve (R). This will allow any trim above the System Main Control Valve (B) to be taken apart for service if necessary.

The frequency at which the following procedures and inspections are to be performed are to be in accordance with the NFPA and any applicable specific requirements of the standards recognized by the Approval agency.

Before closing a fire protection system main control valve for maintenance work on the fire protection system that it controls, permission to shut down the affected fire protection systems must first be obtained from the proper authorities and all personnel who may be affected by this action must be notified.

The owner is responsible for the inspection, testing, and maintenance of their fire protection system and devices in compliance with this document, as well as with the NFPA and any applicable standards recognized by the Approval agency. Contact the installing contractor or product manufacturer with any questions.

Some procedures in this section result in the operation of the associated alarms. Notify the owner and the fire department, central station, or other signal station to which the alarms are connected before performing the tests.

It is recommended that automatic sprinkler systems be inspected, tested, and maintained by a qualified Inspection Service in accordance with the NFPA and any applicable standards recognized by the Approval agency.

Drop in Water Supply Pressure Below Normal Range

NOTICE

If the water supply pressure is significantly reduced below the normally expected static pressure range (as could occur in the case of a water main break or repair), and there is a subsequent drop in the diaphragm chamber water pressure below its normal range (for example, due to a leak in a piping connection to or from the diaphragm chamber or, a leak in the diaphragm chamber check valve caused by dirt or debris in the check valve seal area), a deluge valve such as the DV-5A could inadvertently trip, if its water supply pressure is quickly restored.

A drop in the water supply pressure to below its normal range (as in the case of an interrupted water supply condition) constitutes an emergency impairment.

Should this condition occur, immediately close the System Main Control Valve (B) and use the following procedure to reset the system:

Step 1. Prior to the water supply pressure being restored to the closed System Main Control Valve (B), note the pressure indicated by the Diaphragm Gauge (K) and determine if the pressure is within the normally expected range.

Step 2. If the diaphragm chamber pressure is below the normal range, check for and correct any source of leakage from the diaphragm chamber prior to resetting the system.

Step 3. After the water supply pressure is restored to the System Main Control Valve (B), reset the DV-5A Valve in accordance with the Valve Setting Procedure section.

NOTICE

For fire protection systems subject to an emergency impairment caused by an interrupted water supply condition, it is recommended that consideration be given to installing a low water supply pressure switch with the appropriate alarm/indications to monitor the water supply pressure.

Waterflow Alarm Test Procedure

To test the waterflow alarm, open the Alarm Test Valve (G), which will allow a flow of water to the Waterflow Pressure Switch (C) and/or Water Motor Alarm. Upon satisfactory completion of the test, close the Alarm Test Valve (G).

To ensure drainage of the alarm line, depress the plunger on the Automatic Drain Valve (F).

Dry Pilot Actuation

Operation Test Procedure

Proper operation of the DV-5A Valve, such as opening of the DV-5A Valve as during a fire condition, must be verified as follows:

Step 1. If water must be prevented from flowing beyond the riser, perform the following steps:

- Close System Main Control Valve (B). Open Main Drain Valve (D).
- Open System Main Control Valve (B) one turn beyond position at which water just begins to flow from Main Drain Valve (D).
- Slowly close the Main Drain Valve (D).

Step 2. Open the Inspector's Test Connection.

Note: Be prepared to quickly perform Steps 3, 4, and 5 if water must be prevented from flowing beyond the riser.

Step 3. Verify that the DV-5A Valve has tripped, as indicated by the flow of water into the system.

Step 4. Close the System Main Control Valve (B).

Step 5. Close the Diaphragm Supply Valve (P).

Step 6. Reset the DV-5A Valve in accordance with the Valve Setting Procedure.

Low Pressure Alarm and Condensate Drain for Dry Pilot Actuation Test Procedures

For Dry Pilot Actuation, testing of the Dry Pilot Low Pressure Switch (T) and drainage of the pilot line condensate must be performed as follows:

Step 1. Close the System Main Control Valve (B).

Step 2. Close the Diaphragm Supply Valve (P).

Step 3. Open the Main Drain Valve (D).

Step 4. Open the Inspector's Test Connection, and slowly relieve pneumatic pressure. Verify that the Dry Pilot Low Pressure Switch (T) is operational and that the low pressure set points are as follows:

- Low pressure alarm setting at approximately 6 psi (0,4 bar) below the minimum pilot line service pressure requirement shown in Graph B
- Fire alarm setting at approximately 14.5 psi (1,0 bar) below the minimum pilot line service pressure requirement shown in Graph B.

Item	Description
A	DV-5A Valve
B	System Main Control Valve
C	Waterflow Pressure Switch
D	Main Drain Valve
E	System Drain Valve
F	Automatic Drain Valve
G	Alarm Test Valve
H	Alarm Control Valve (Optional)
J	Water Supply Gauge
K	Diaphragm Gauge
L	System Gauge (Optional)

Item	Description
M	Manual Control Station
N	Manual Reset Actuator
P	Diaphragm Supply Valve
Q	Diaphragm Supply Strainer
R	Inverted Flare Shut-Off Valve
S	Dry Pilot Actuator
T	Low Air Pressure Alarm Switch
U	Dry Pilot Air Supply Valve
V	Dry Pilot Line Gauge
W	Pressure Relief Valve

External Trim Connections	
C1	Diaphragm Supply Connection
C2	Water Motor Alarm Connection
C3	Dry Pilot Line Connection
C4	Dry Pilot Air Supply Connection
C5	Waterflow Pressure Alarm Switch Connection
C6	Low Air Pressure Switch Connection
C7	Main Drain Connection
C8	Drip Funnel Drain Connection

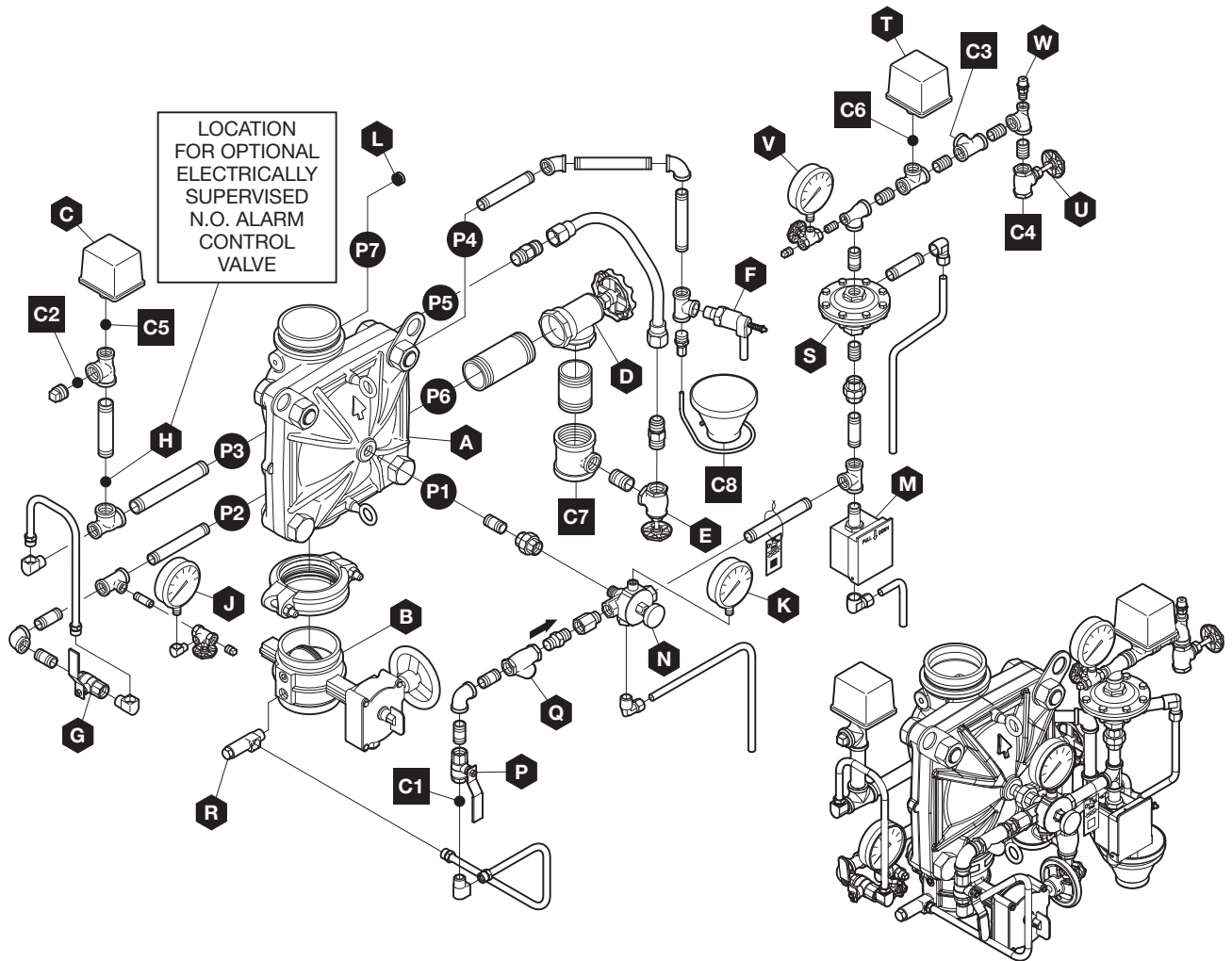

NOTES
 Port Connections P1 through P7 are described in Figure 2.

FIGURE 8
DV-5A VALVE
DELUGE DRY PILOT ACTUATION TRIM
 (Refer To Figure 11 For Specific Bills Of Materials)

Nominal Valve Sizes ANSI Inches (DN)	Torque lb-ft (N·m)	
	Nuts	Short Hex Bolts
1 1/2 (40)	44 (59,7)	35 (47,5)
2 (50)	44 (59,7)	35 (47,5)
3 (80)	125 (169,5)	125 (169,5)
4 (100)	150 (203,4)	150 (203,4)
6 ¹ (150)	150 (203,4)	150 (203,4)
8 (200)	188 (254,9)	188 (254,9)

NOTES

1. Also applicable to metric 165,1 mm size.

**TABLE B
DIAPHRAGM COVER BOLTS
MINIMUM TORQUE**

Step 5. Close the Inspector's Test Connection and allow the Dry Pilot Line to automatically repressurize.

Step 6. Individually open each low point drain and then close after discharge of any trapped condensate.

The gauge test valve to which the Dry Pilot Line Gauge (V) is connected must be used as a low point drain. Close the gauge test valve, remove the plug, and partially open the gauge test valve (as necessary, collect water in a cup). After condensate water ceases to drain, close the gauge test valve, replace the plug, and then completely open the gauge test valve.

Step 7. Allow the Dry Pilot Line to automatically repressurize.

Step 8. Open the Diaphragm Supply Valve (P).

Step 9. Partially open the System Main Control Valve (B). slowly close the Main Drain Valve (D) as soon as water discharges from the Main Drain Valve (D). Observe the Automatic Drain Valve (F) for leaks. If there are leaks, determine/correct the cause of the leakage problem. If there are no leaks, the DV-5A Valve is ready to be placed in service and the System Main Control Valve (B) must then be fully opened.

Internal Valve Inspection

Once every five years during the annual operational test procedure, and prior to the DV-5A Valve being reset and the DV-5A Valve de-pressurized, the interior of the DV-5A Valve must be cleaned and inspected for wear and damage. Damaged or worn parts must be replaced. Replacement of the Diaphragm every ten years is recommended, or more frequently if inspections and/or wear and tear of the Diaphragm warrants more frequent replacement.

NOTICE

The Diaphragm Cover may be removed between Steps 4 and 5 of the Valve Setting Procedure instructions, since at that point the DV-5A Valve should be de-pressurized as evident by a zero gauge reading on the Diaphragm Gauge (K) and Water Supply Gauge (J), as well as no water discharging from the Automatic Drain Valve (F).

To perform internal valve inspection between Steps 4 and 5 of the Valve Setting Procedure, remove the Diaphragm cover as follows:

Step 1. Close the Inverted Flare Shut-Off Valve (R).

Step 2. Remove the Copper Tube Fitting between the Diaphragm Supply Valve (P) and the Inverted Flare Shut-Off Valve (R).

Step 3. Loosen the union securing the Dry Pilot Actuation Trim and remove the Actuation Trim.

Step 4. Loosen and remove the union between the Diaphragm Cover and the MRA-1 Manual Reset Actuator (N) and remove the MRA-1 Manual Reset Actuator (N) subassembly.

Step 5. Remove the Diaphragm Valve Cover hardware, then slowly remove the Diaphragm Cover and perform internal valve inspection. Clean the valve interior and replace parts as necessary.

After cleaning and inspecting valve interior, and replacing parts as necessary, reinstall the Diaphragm Cover by completing the following steps to assure the Diaphragm Cover Fasteners are uniformly and securely tightened.

Step 1. With reference to Figure 1, ensure that the Diaphragm is properly oriented and that the proper hardware arrangement is utilized when assembling the Diaphragm Covers. The hardware arrangements differ depending on the size of the DV-5A Valve.

Step 2. By first using the Long Hex Bolts, support of the Diaphragm Cover will be provided before installing the Short Hex Bolts. Align Diaphragm in proper orientation with Valve Body, and then align Diaphragm Cover in proper orientation with Valve Body. Hand-tighten all fasteners.

Step 3. Using crossdraw sequence to assure uniformity, wrench-tighten Long Hex Bolts and Short Hex Bolts to appropriate torque values. Repeat crossdraw sequence two to three times at incremental torque valves until reaching the torque valves found in Table C.

Step 4. Inspect to assure all Hex Bolts are securely tightened.

Step 5. Using the union, secure the MRA-1 Manual Reset Actuator to the Diaphragm Cover.

Step 6. Using the union, secure the Dry Pilot Actuation Trim.

Step 7. Replace the Copper Tube Fitting between the Diaphragm Supply Valve (P) and the Inverted Flare Shut-Off Valve (R).

Step 8. Ensure that the unions and flare fittings are securely tightened.

Step 9. With the Diaphragm Supply Valve (P) closed, fully open the Inverted Flare Shut-Off Valve (R) stainless steel screw (approximately 1/2 in.) until resistance is met so as not to break the internal roll-pin. The internal roll-pin stops the removal of the Inverted Flare Shut-Off Valve (R) stainless steel screw.

Step 10. Proceed with Step 5 of the Valve Setting Procedures section in this data sheet.

NOTICE

If the water supply contains chemicals which tend to attack a polyester fabric-reinforced, EPDM rubber or the five year inspection indicates a build-up of debris within the DV-5A Valve that could affect its proper operation, then the frequency of the internal valve inspection procedure must be appropriately increased.

With reference to Figure 1, make certain that the Diaphragm is correctly oriented; otherwise, the DV-5A Deluge Valve cannot be properly set.

Under-tightening the Diaphragm Cover Bolts can result in internal and external leakage.

Use only TYCO replacement fasteners as specified in Figure 1.

Do not apply adhesives, lubricants, or other substances to the Diaphragm or Valve Body.

Limited Warranty

For warranty terms and conditions, visit
www.tyco-fire.com.

Ordering Procedure

The TYCO DV-5A Automatic Water Control Valve Dry Pilot Actuation may be ordered as follows:

Pre-Assembled Valves with Trim

DV-5A Valves with Galvanized Trim and Butterfly Valve

Specify: Size (specify), DV-5A Automatic Water Control Valve, G x G connections with assembled galvanized Americas Dry Pilot Actuation Trim, complete with assembled Model BFV-300 Butterfly Valve, P/N (specify):

1 1/2 in. (DN40)	551010215
2 in. (DN50)	551010220
3 in. (DN80)	551010230
4 in. (DN100)	551010240
6 in. (DN150)	551010260
8 in. (DN200)	551010280

Note: Americas pressure switches and psi/kPa water pressure gauges are provided.

This arrangement is available for EMEA and APAC upon request. Contact your local distributor.

AMERICAS

DV-5A Valves with Galvanized Trim
Specify: Size (specify), DV-5A Automatic Water Control Valve, (specify) end connection with assembled galvanized Americas, Dry Pilot Actuation Trim, P/N (specify):

Groove x Groove	
1 1/2 in. (DN40)	550010215
2 in. (DN50)	550010220
3 in. (DN80)	550010230
4 in. (DN100)	550010240
6 in. (DN150)	550010260
8 in. (DN200)	550010280

Flange x Flange ANSI	
3 in. (DN80)	550020230
4 in. (DN100)	550020240
6 in. (DN150)	550020260
8 in. (DN200)	550020280

Flange x Groove ANSI	
3 in. (DN80)	550030230
4 in. (DN100)	550030240
6 in. (DN150)	550030260
8 in. (DN200)	550030280

Thread x Thread NPT	
1 1/2 in. (DN40)	550060215
2 in. (DN50)	550060220

Note: Pressure switches and psi/kPa water pressure gauges are provided.

Separate DV-5A Valves without Trim
See Table A for flange drilling specifications.

Specify: Size (specify), DV-5A Automatic Water Control Valve, (specify) end connection, P/N (specify):

Groove x Groove	
1 1/2 in. (DN40)	530010015
2 in. (DN50)	530010020
3 in. (DN80)	530010030
4 in. (DN100)	530010040
6 in. (DN150)	530010060
8 in. (DN200)	530010080

Flange x Flange ANSI	
3 in. (DN80)	530020030
4 in. (DN100)	530020040
6 in. (DN150)	530020060
8 in. (DN200)	530020080

Flange x Groove ANSI	
3 in. (DN80)	530030030
4 in. (DN100)	530030040
6 in. (DN150)	530030060
8 in. (DN200)	530030080

Thread x Thread NPT	
1 1/2 in. (DN40)	530060015
2 in. (DN50)	530060020

Note: Valves are typically provided with flange drilling per ANSI B16.1 (Class 125) or ISO (7005-2 PN16).

Upon request, valves can be provided with flange drilling per JIS B 2210 or AS 2129. In which case part numbers are not assigned.

DV-5A Valve Trim Semi-Assembled
Specify: Size (specify), finish (specify), Dry Pilot Actuation Trim for DV-5A Automatic Water Control Valves used in Deluge Fire Protection System, P/N (specify):

Galvanized	
1 1/2 in. (DN40)	540000220
2 in. (DN50)	540000220
3 in. (DN80)	540000230
4 in. (DN100)	540000240
6 in. (DN150)	540000260
8 in. (DN200)	540000280

Black	
1 1/2 in. (DN40)	542000220
2 in. (DN50)	542000220
3 in. (DN80)	542000230
4 in. (DN100)	542000240
6 in. (DN150)	542000260
8 in. (DN200)	542000280

EMEA

DV-5A Valves with Galvanized Trim
Specify: Size (specify), DV-5A Automatic Water Control Valve, (specify) end connection with assembled galvanized EMEA, Dry Pilot Actuation Trim, P/N (specify):

Groove x Groove	
1 1/2 in. (DN40)	550110215
2 in. (DN50)	550110220
3 in. (DN80)	550110230
4 in. (DN100)	550110240
6 in. (DN150)	550110260
165,1 mm	550110266
8 in. (DN200)	550110280

Flange x Flange ANSI	
3 in. (DN80)	550120230
4 in. (DN100)	550120240
6 in. (DN150)	550120260
8 in. (DN200)	550120280

Flange x Groove ANSI	
3 in. (DN80)	550130230
4 in. (DN100)	550130240
6 in. (DN150)	550130260
8 in. (DN200)	550130280

Flange x Flange ISO	
3 in. (DN80)	550140230
4 in. (DN100)	550140240
6 in. (DN150)	550140260
8 in. (DN200)	550140280

Flange x Groove ISO	
3 in. (DN80)	550150230
4 in. (DN100)	550150240
6 in. (DN150)	550150260
8 in. (DN200)	550150280

Thread x Thread ISO	
1 1/2 in. (DN40)	550170215
2 in. (DN50)	550170220

Note: Pressure switches, bar/psi water pressure gauges, and NPT to ISO threaded trim adaptors for external connections are provided.

VdS and LPCB Approved DV-5A Valves with Galvanized Trim
Specify: VdS and LPCB Approved, Size (specify), DV-5A Automatic Water Control Valve, (specify) end connection with assembled galvanized Dry Pilot Actuation Trim, P/N (specify):

Groove x Groove	
1 1/2 in. (DN40)	550110215VDS
2 in. (DN50)	550110220VDS
3 in. (DN80)	550110230VDS
4 in. (DN100)	550110240VDS
6 in. (DN150)	550110260VDS
8 in. (DN200)	550110280VDS

Flange x Flange ANSI	
3 in. (DN80)	550120230VDS
4 in. (DN100)	550120240VDS
6 in. (DN150)	550120260VDS
8 in. (DN200)	550120280VDS

Flange x Groove ANSI	
3 in. (DN80)	550130230VDS
4 in. (DN100)	550130240VDS
6 in. (DN150)	550130260VDS
8 in. (DN200)	550130280VDS

Flange x Flange ISO	
3 in. (DN80)	550140230VDS
4 in. (DN100)	550140240VDS
6 in. (DN150)	550140260VDS
8 in. (DN200)	550140280VDS

Flange x Groove ISO	
3 in. (DN80)	550150230VDS
4 in. (DN100)	550150240VDS
6 in. (DN150)	550150260VDS
8 in. (DN200)	550150280VDS

Thread x Thread ISO	
1 1/2 in. (DN40)	550170215VDS
2 in. (DN50)	550170220VDS

Note: EMEA pressure switches, bar/psi water pressure gauges, NPT to ISO threaded trim adaptors for external connections, and VdS and LPCB required water column prevention drain components are provided.

Separate DV-5A Valves without Trim
 See Table A for flange drilling specifications.

Specify: Size (specify), DV-5A Automatic Water Control Valve, (specify) end connection, P/N (specify):

Groove x Groove

1 1/2 in. (DN40)	530010015
2 in. (DN50)	530010020
3 in. (DN80)	530010030
4 in. (DN100)	530010040
6 in. (DN150)	530010060
165,1 mm	530010066
8 in. (DN200)	530010080

Flange x Flange ANSI

3 in. (DN80)	530020030
4 in. (DN100)	530020040
6 in. (DN150)	530020060
8 in. (DN200)	530020080

Flange x Groove ANSI

3 in. (DN80)	530030030
4 in. (DN100)	530030040
6 in. (DN150)	530030060
8 in. (DN200)	530030080

Thread x Thread NPT

1 1/2 in. (DN40)	530060015
2 in. (DN50)	530060020

Flange x Flange ISO

3 in. (DN80)	530040030
4 in. (DN100)	530040040
6 in. (DN150)	530040060
8 in. (DN200)	530040080

Flange x Groove ISO

3 in. (DN80)	530050030
4 in. (DN100)	530050040
6 in. (DN150)	530050060
8 in. (DN200)	530050080

Thread x Thread ISO

1 1/2 in. (DN40)	530070015
2 in. (DN50)	530070020

Note: Valves are typically provided with flange drilling per ANSI B16.1 (Class 125) or ISO (7005-2 PN16).

Upon request, valves can be provided with flange drilling per JIS B 2210 or AS 2129. In which case part numbers are not assigned.

DV-5A Valve Trim
 Specify: Size (specify), finish (specify), Dry Pilot Actuation Trim for DV-5A Automatic Water Control Valves used in Deluge Fire Protection System, P/N (specify):

Galvanized

1 1/2 in. (DN40)	540100220
2 in. (DN50)	540100220
3 in. (DN80)	540100230
4 in. (DN100)	540100240
6 in. (DN150)	540100260
8 in. (DN200)	540100280

Black

1 1/2 in. (DN40)	542100220
2 in. (DN50)	542100220
3 in. (DN80)	542100230
4 in. (DN100)	542100240
6 in. (DN150)	542100240
8 in. (DN200)	542100280

Note: Pressure switches, water pressure gauges, and BFV-300 Butterfly Valve are separately ordered. NPT to ISO threaded adaptors are provided for External Trim Connections (drains, pressure switches, water motor alarms, etc.).

APAC

DV-5A Valves with Galvanized Trim
 Specify: Size (specify), DV-5A Automatic Water Control Valve, (specify) end connection with assembled galvanized APAC, Dry Pilot Actuation Trim, P/N (specify):

Groove x Groove

1 1/2 in. (DN40)	550010215
2 in. (DN50)	550010220
3 in. (DN80)	550010230
4 in. (DN100)	550010240
6 in. (DN150)	550010260
165,1 mm	550010266
8 in. (DN200)	550010280

Flange x Flange ANSI

3 in. (DN80)	550020230
4 in. (DN100)	550020240
6 in. (DN150)	550020260
8 in. (DN200)	550020280

Flange x Groove ANSI

3 in. (DN80)	550020230
4 in. (DN100)	550020240
6 in. (DN150)	550020260
8 in. (DN200)	550020280

Thread x Thread NPT

1 1/2 in. (DN40)	550060215
2 in. (DN50)	550060220

Flange x Flange ISO

3 in. (DN80)	550040230
4 in. (DN100)	550040240
6 in. (DN150)	550040260
8 in. (DN200)	550040280

Flange x Groove ISO

3 in. (DN80)	550050230
4 in. (DN100)	550050240
6 in. (DN150)	550050260
8 in. (DN200)	550050280

Note: Pressure switches and psi/kPa water pressure gauges are provided

Separate DV-5A Valves without Trim
 See Table A for flange drilling specifications.

Specify: Size (specify), DV-5A Automatic Water Control Valve, (specify) end connection, P/N (specify):

Groove x Groove

1 1/2 in. (DN40)	530010015
2 in. (DN50)	530010020
3 in. (DN80)	530010030
4 in. (DN100)	530010040
6 in. (DN150)	530010060
165,1 mm	530010066
8 in. (DN200)	530010080

Flange x Flange ANSI

3 in. (DN80)	530020030
4 in. (DN100)	530020040
6 in. (DN150)	530020060
8 in. (DN200)	530020080

Flange x Groove ANSI

3 in. (DN80)	530030030
4 in. (DN100)	530030040
6 in. (DN150)	530030060
8 in. (DN200)	530020080

Thread x Thread NPT

1 1/2 in. (DN40)	530060015
2 in. (DN50)	530060020

Flange x Flange ISO

3 in. (DN80)	530040030
4 in. (DN100)	530040040
6 in. (DN150)	530040060
8 in. (DN200)	530040080

Flange x Groove ISO

3 in. (DN80)	530050030
4 in. (DN100)	530050040
6 in. (DN150)	530050060
8 in. (DN200)	530050080

Thread x Thread ISO

1 1/2 in. (DN40)	530070015
2 in. (DN50)	530070020

Note: Valves are typically provided with flange drilling per ANSI B16.1 (Class 125) or ISO (7005-2 PN16).

Upon request, valves can be provided with flange drilling per JIS B 2210 or AS 2129. In which case part numbers are not assigned.

DV-5A Valve Trim
 Specify: Size (specify), finish (specify), Dry Pilot Actuation Trim for DV-5A Automatic Water Control Valves used in Deluge Fire Protection System, P/N (specify):

Galvanized

1 1/2 in. (DN40)	540000220
2 in. (DN50)	540000220
3 in. (DN80)	540000230
4 in. (DN100)	540000240
6 in. (DN150)	540000260
8 in. (DN200)	540000280

Black

1 1/2 in. (DN40)	542000220
2 in. (DN50)	542000220
3 in. (DN80)	542000230
4 in. (DN100)	542000240
6 in. (DN150)	542000260
8 in. (DN200)	542000280

Note: Pressure switches are separately ordered.

Valve Trim Accessories

DV-5A Valve Trim Accessories (for separately ordered valve trim)
 Specify: (specify accessory description), P/N (specify):

Waterflow Pressure Alarm Switch, Potter PS10-2 (America/APAC)	25720
Waterflow Pressure Alarm Switch PS10-1 (EMEA)	0260
Air Pressure Alarm Switch, Potter PS40-2 (America/APAC)	25710
Air Pressure Alarm Switch PS40-1 (EMEA)	0262
Model WMA-1 Water Motor Alarm (America/APAC)	526301001P
Model WMA-1 Water Motor Alarm (EMEA)	526301021R
Model AMD-1 Air Maintenance Device	523242002
Model AMD-2 Air Maintenance Device	523262001
Model AMD-3 Nitrogen Maintenance Device	523282001
Model MC-1 Manual Control Stations	522892001
Water Gauges with bar/psi	025500013
600 psi Water Gauge psi/kPa (service pressure over 300 psi)	923431004

DV-5A Valve Replacement Parts
 Specify: (Description) for use with (specify size) DV-5A Automatic Water Control Valve, P/N (See Figure 1)

DV-5A Valve Trim Replacement Parts
 Specify: (Description) for use with DV-5A Valve Trim, P/N (See Figure 6)

