

CHP SERIES

FULLY INTEGRATED HEAT PUMP WATER HEATER

The CHP-120 heat pump water heater is an integrated system designed specifically for the commercial market.

FEATURES

ENERGY SAVING AND ENVIRONMENTALLY FRIENDLY

- Heat pump transfers heat from surrounding area into the tank
- Industry leading 4.2 COP
- Multiple operating modes maximizes efficiency while meeting specific hot water needs
- Large capacity tank enables heat pump to operate more frequently than electric elements, saving money for the end user
- Meets the standby loss requirements of U.S. Department of Energy and the current edition of ASHRAE 118.1
- Environmentally friendly R-134a refrigerant
- ENERGY STAR® Qualified

COMMERCIAL PERFORMANCE

- First hour delivery of 179 GPH
- Rated heat pump power of 3.15 HP (240Vac) or 3.05 (208Vac)
- Electric heating element capacity of 12 kW (240Vac) or 9 kW (208Vac)
- Max water temperature of 150°F in efficiency/Hybrid modes and 180°F in electric mode
- Operating ambient range of 40-110° F
- Low operating sound measured at 59 dB (A)
- Dual evaporator fans maximize performance and provide room cooling
- 3/4" NPT water inlet and outlet

EASE OF OPERATION

- Integrated design and pre-charged refrigeration system makes for quick and easy install
- Large touch screen LCD display allows for mode selection, provides run information and includes troubleshooting alerts and detail
- Choose from three operating modes: Efficiency, Hybrid or Electric

DEPENDABLE AND LONG LASTING DESIGN

- A. O. Smith-developed glass coated tank
- Tank rated at 160 PSI working pressure
- Commercial grade anode protects the tank and extends the service life
- Proven heat pump technology
- Electric elements have incoloy sheathing and provide excellent protection from oxidation and scaling

THREE YEAR LIMITED TANK WARRANTY

- Backed by 3-year tank and 1-year parts/compressor limited warranties
- For complete warranty information, consult written warranty or go to hotwater.com



MODEL CAHP 120



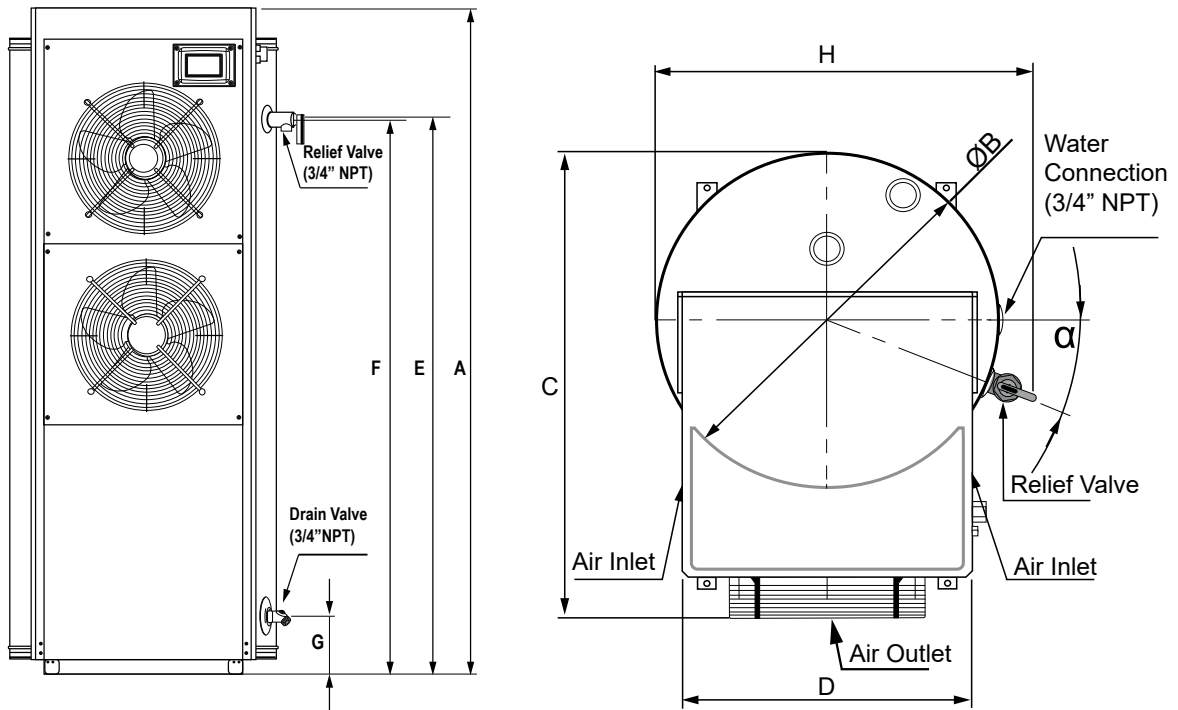

ROUGH-IN DIMENSIONS

Physical Dimensions								
Total Height (A)	Tank Diameter (B)	Maximum Depth (C)	Service Panel Width (D)	Relief Valve Height (E)	Water Outlet Height (F)	Water Inlet Height (G)	Relief Valve Angle α (°)	Maximum Width (H)
69 11/16	28 1/32	39 11/64	23 5/8	58 7/64	57 51/64	6 1/32	22	30 29/32

MODEL SPECIFICATIONS

Model Number	Nominal Capacity	COP	Number of Elements	Total Element Wattage (both elements at 240V)	First Hour Delivery in Hybrid Mode (Gallons)	Recovery in GPH at 100° Temperature Rise in Hybrid Mode	Depends on mode of operation per chart below:	Approx. Shipping Weight (lbs)
CAHP 120	119	4.2	2	12,000	179	90	Efficiency = 41 Hybrid = 90 Electric = 50	620



COMMERCIAL HEAT PUMP WATER HEATERS

RECOVERY CAPACITIES

Recovery Rate In Gallons Per Hour															
Mode of Operation	Input		Temperature Rise °F												
	BTU/ Hour	kW	°F	30°F	40°F	50°F	60°F	70°F	80°F	90°F	100°F	110°F	120°F	130°F	140°F
			°C	17°C	22°C	28°C	33°C	39°C	45°C	50°C	56°C	61°C	67°C	72°C	78°C
Efficiency	33,678	10	GPH	136	102	82	68	58	51	45	41	37	34	31	29
			LPH	515	386	309	258	221	193	172	155	140	129	119	110
Hybrid	74,624	22	GPH	302	226	181	151	129	113	101	90	82	75	70	65
			LPH	1141	856	685	571	489	428	380	342	311	285	263	245
Electric	40,946	12	GPH	165	124	99	83	71	62	55	50	45	41	38	35
			LPH	626	470	376	313	268	235	209	188	171	157	145	134

Technical Characteristics	
Model Type	Integrated Heat Pump Water Heater
COP	4.2
HP Rated Input Power	3.15 HP (2.35 kW)
HP Rated Heating Output Capacity	11.13 kW
Power Specification	208/240Vac ~ 60Hz 1Ph
Maximum Operation Current	67 A
Refrigerant	R134a
Refrigerant Charge Quantity	3.3 Lbs (1.5 Kg)
Electrical Heating Capacity	12.0 kW @ 240Vac and 9.0 kW @ 208Vac
Measured Tank Capacity	111.76 Gal (423 L)
Operation Modes	Efficiency, Hybrid, Electric
Max. Water Temperature	Efficiency/Hybrid
	Electric
	150°F (66°C)
	180°F (82°C)
Operating Ambient Temperature	40 - 110°F (4.4 - 43.3°C)
Unit Operation Noise	59 dB (A)
Approx. Heater Weight	498 Lbs (226 Kg)
Approx. Shipping Weight	620 Lbs (281 Kg)



COMMERCIAL HEAT PUMP WATER HEATERS

Installation Key Considerations	
Service clearances	A service clearance of 24 inches should be maintained from serviceable parts such as the T&P valve, control system components, drain valve, and anode.
Ambient air temperature	In Efficiency Mode the ambient air temperature must be above 40°F and below 110°F
Room size requirement	Recommended to have a minimum installation space of approximately 3,200 cubic feet. Installation spaces less than the recommended could result in reduced water heater efficiency and performance. If the water heater is installed in a confined space with less than 3,200 cubic feet, provisions should be made to ensure sufficient airflow, such as installing louvered grills or fully louvered doors to ensure the most efficient operation of the water heater. Failure to do so could result in reduced heater efficiency and performance.
Amperage/Overcurrent protection	This water heater requires a 208 or 240 VAC single phase power supply. 208V requires 80 amp power supply at 60 Hz; 240V requires 90 amp power supply at 60 Hz.
Condensate draining	This water heater produces condensate and must be properly drained.
Ducting	There is not an optional ducting kit. Discharge air from the front of the water heater must be into a suitable room.
Indoor/Outdoor	This water heater is approved for indoor use only.
This is a partial list. Please reference the Installation Manual for detailed installation considerations.	

SUGGESTED SPECIFICATION

The heater(s) shall be Commercial Heat Pump Model Number CAHP 120 as manufactured by A. O. Smith Water Products Company or equivalent. Heater(s) shall be rated at 12 kW @ 240V or 9 kW @ 208V, single phase, 60 cycle AC as listed by Underwriters' Laboratories. All models meet National Sanitation Foundation NSF-5 requirements. Water heater shall have LCD display with built-in diagnostic and troubleshooting information. Tank(s) shall be 119 gallon capacity with 160 psi working pressure and equipped with a commercial grade anode. All internal surfaces of the heater(s) exposed to water shall be glass-lined with an alkaline borosilicate composition that has been fused to steel by firing at a temperature range of 1400°F to 1600°F. Internal power circuit fusing shall be provided. The heat pump water heater shall be capable of operating in Efficiency, Hybrid or Electric only modes. 3/4" NPT inlet and outlet water connections shall be provided. The water heater tank shall have a three year limited warranty; the compressor, refrigeration components and all other parts shall have a one year limited warranty. Fully illustrated instruction manual to be included. Meets or exceeds the efficiency and standby loss requirements of the U.S. Department of Energy and current edition of ASHRAE 118.1.

For technical information, call 800-527-1953. A. O. Smith Corporation reserves the right to make product changes or improvements without prior notice.