

WaterGroup®



PRODUCT CATALOG

Water Conditioning Products
For the Plumbing Professional



WaterGroup®

Our Mission is to provide customers with **EXCEPTIONAL VALUE** for their hard earned dollar.

We have been in the Water Conditioning Manufacturing & Distribution Business in North America for over 50 Years.

We believe our longevity is a testament to our singular focus on value creation by Efficiently delivering Innovative, High Quality Products - all backed with Expert Support.



Canature WaterGroup has over **50 years of Innovation, Quality, Efficiency ... and Growth!** Our focus has not changed much since I started the business back in 1968! Our mission has always been to create the most value possible for our customers. As a result, we have built many long-term partnerships over the years. I call them partnerships because that is really what they are. Our success depends on our customers' success.

I want to thank our customers, old and new, for being great partners and allowing myself and my team to have continued success in an industry we are very passionate about.

Don Fettes, President & CEO



Corporate Capability Brochure Circa 1989



Trade & Commerce Magazine 1977





Continuous Innovation

- Consumer Driven Features That Set You Apart
- Leading High-Efficiency Technology
- Dedicated Product Development Team
- Fast, Efficient Innovation - From Design to Finished Product to Your Door

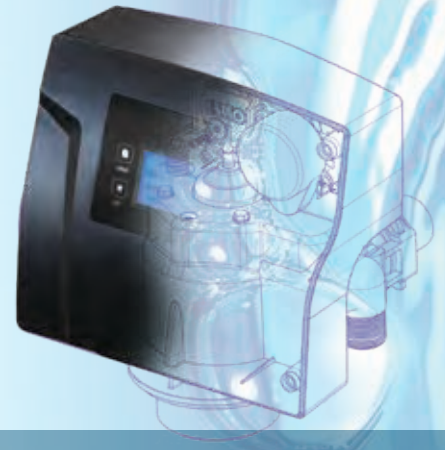

Superior Quality

- ISO9001:2008 Certified, 1,200,000 sq ft Manufacturing Facility
- World Class Testing Laboratory
- Dedicated Quality Control Team
- 3rd Party Certified Systems & Components



Industry Expertise

- Over 150 Factory Trained Employees
- Largest Field Sales Force in North America
- Customer Service Team Averaging 20+ Years
- Over 15 P. Eng. & PhD's on Staff
- Dedicated Commercial Engineering Division



Higher Efficiency

- Manufacturer-Direct Business Model Eliminates Non-Value Added Activity
- State-of-the Art Manufacturing Ensures High Quality Products at the Lowest Possible Cost



U.S. Head Office Carmel, IN

9760 Mayflower Park Dr.
Suite 110, 46032

Distribution Centers: Phoenix, AZ

4655 W McDowell Road Suite 108,
85035

Pottstown, PA

56 Lightcap Road, 19464

WaterGroup®

1-877-288-9888

www.watergroup.com

Technical Support

supportusa@canaturewg.com
supportcanada@canaturewg.com

Order Desk

ordersusa@canaturewg.com
orderscanada@canaturewg.com

Canadian Head Office Regina, SK

855 Park St., Regina, SK S4N 6M1

Distribution Center:

Cambridge, ON

490 Pinebush Road,
Unit 1, N1T 0A5

A Division of



TABLE OF CONTENTS

5 - 11

About WaterGroup

WaterGroup®



12 - 19

Water Conditioning Basics



20 - 47

Water Softeners, Filters & Specialty Systems



47 - 62

Aqua Flo and Aqua Flo Platinum Drinking Water Systems

Reverse Osmosis, Ultra Filtration, Under Sink Filtration, Designer Faucets & Accessories



63 - 83

Aqua Flo Ultraviolet Disinfection Systems



84 - 99

Aqua Flo Point-of-Use Filtration Products



100 - 119

Accessories

Chemical Feed Pumps, Pro Chemicals, Test Kits, Mazzei Injectors, John Guest Fittings

120 - 122

Marketing Materials



123

Commercial Systems



124 - 128

Water Conditioning Glossary

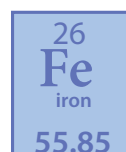

Water Group Key Dealer Program



Turn Opportunity into Profit With a Program That Offers REAL Value!

The **WaterGroup Key Dealer Program** is specifically developed for the dedicated plumbing professional who wants to make the most out of the water conditioning segment of their business.

LEVEL ONE BASIC TRAINING

➤ Online Video Training

Complete our simple on-line **video-based basic training program** today & we'll give you all the tools you need to get started making the most out of the growing water conditioning market!

- Test Kits
- Sizing Guide
- Sales Materials



UPON COMPLETION WE'LL SEND YOU A **FREE WATER CONDITIONING STARTER KIT (RETAIL VALUE \$50) ...**

LEVEL TWO CERTIFIED INSTALLER

➤ Comprehensive Hands-on Training

Work with one of WaterGroup's **Regional Sales Managers** to complete the **Level Two Comprehensive Training Program** and get your **Certified Installer Marketing Tool Kit** for **FREE!**

- Certified Uniform Patch
- Vehicle Decals
- Showroom Poster
- Certified Installer Wall Certificate
- And **MORE!** ...



Custom display stand



Vehicle decal



Water sample kit



FREE framed certificates and uniform patches upon completion.

REGISTER TODAY! @ www.watergroup.com

Water Testing Services

Recommending a proper solution starts with a water analysis. Labs in Regina, Cambridge, Carmel, IN & Golden Valley can test your water samples for:

- 1) Hardness
- 2) Iron
- 3) Manganese
- 4) pH
- 5) Tannins
- 6) TDS



WaterGroup
Water Analysis Report

FOR LABORATORY USE ONLY:
Date Received: _____
Analyst: _____
Lab Computer: _____

WRITE These names (or Customer Numbers) in pencil on each customer recommendation:

CUSTOMER	DEALER	DISTRIBUTOR
Name: _____	Name: _____	Name: _____
Address: _____	Address: _____	Address: _____
City: _____	City: _____	City: _____
State: _____	State: _____	State: _____
Zip: _____	Zip: _____	Zip: _____

Customer Number: _____
 Dealer Number: _____
 Distributor Number: _____

Water System:
 Type: _____
 Use: _____
 Description: _____

Water Problems:
 When the sample was taken: _____
 Cause: _____
 This water sample is: _____
 Name of Reservoir: _____

PROBLEMS:
 1. Hardness (or high iron usage, both high iron usage and high iron usage)
 2. Iron
 3. Manganese
 4. Tannins
 5. pH
 6. Total Dissolved Solids (TDS)

Standard Laboratory Tests

Total Hardness _____ mg/l
 Iron _____ mg/l
 Manganese _____ mg/l
 pH _____
 Total Dissolved Solids _____ mg/l

Other Tests
 Hydrogen Sulfide _____ mg/l
 (test must be performed on site)
 Turbidity _____ NTU

Special Laboratory Tests
 Chloride _____ mg/l
 Sulfate _____ mg/l
 Alkalinity _____ mg/l

If TDS is over 1000 ppm and hardness is less than 30% of the TDS, a total water analysis is required.

Explanation of Water Analysis

A. Total Hardness
 This indicates the efficiency or suitability of the water for everyday household use. Values in excess of 3 gpt are generally considered hard and should be softened.

B. Iron
 Over 0.3 ppm of iron will cause discoloration of white laundry, yellowing of water, and staining of fixtures. High iron concentrations will cause a metallic taste. Some systems water solutions may require filtration.

C. Manganese
 Manganese is frequently associated with iron-bearing water but is a more dangerous. Manganese is similar to iron in that it stains and clogs pipes and valves. Concentrations as low as 0.05 mg/l of manganese can cause problems.

Recommendations
 Recommendations are based strictly on the individual supplied and the water sample analysis results in the field or samples.

Recommended by: _____ (Please print name here)
 Date: _____

WaterGroup

Water Testing Kits & Sample Bottles



WaterGroup sells a complete line of easy to use test kits so you can accurately test water in the field. Not sure of the proper product application? Give us a call with the results and we'll provide you with a product recommendation. Water Sample Collection Kits are available at Stocking Wholesalers & include a sample bottle, mailing tube and sample collection instructions.



If you have concerns about the safety (potability) of the water supply we recommend a complete water analysis be conducted. These are usually conducted for a small fee at a State or Provincial Lab.

Operations & Product Development



Toby Hughes has managed some of the industries largest water conditioning manufacturing operations as well as toured the facilities of most industry manufacturers across the globe.

Toby brings over 20 years of extensive industry experience to WaterGroup. Toby has managed product development as well as implemented Lean manufacturing, Continuous Improvement and Quality Assurance programs, MRP (Material Requirement Planning) systems to create an efficient, low cost and quality driven manufacturing environment.

Toby Hughes P. Eng.
Chief Operations Officer

"The WaterGroup Product Development Center and manufacturing operations are beyond comparison in our industry. The investment in technology and commitment to leading manufacturing practices & innovation has resulted in higher quality and lower cost products with meaningful 'Installer / Service Driven' features. This all adds up to better value for our customers.

My staff of 17 Professional Engineers, including 3 PhD's and 2 Masters, are some of the brightest minds in the industry. I am excited to lead WaterGroup's Global Engineering and Operations and raise the bar beyond industry standards and our customers expectations."

A handwritten signature in black ink that reads "Toby Hughes".

Toby Hughes, P.Eng., Chief Operations Officer

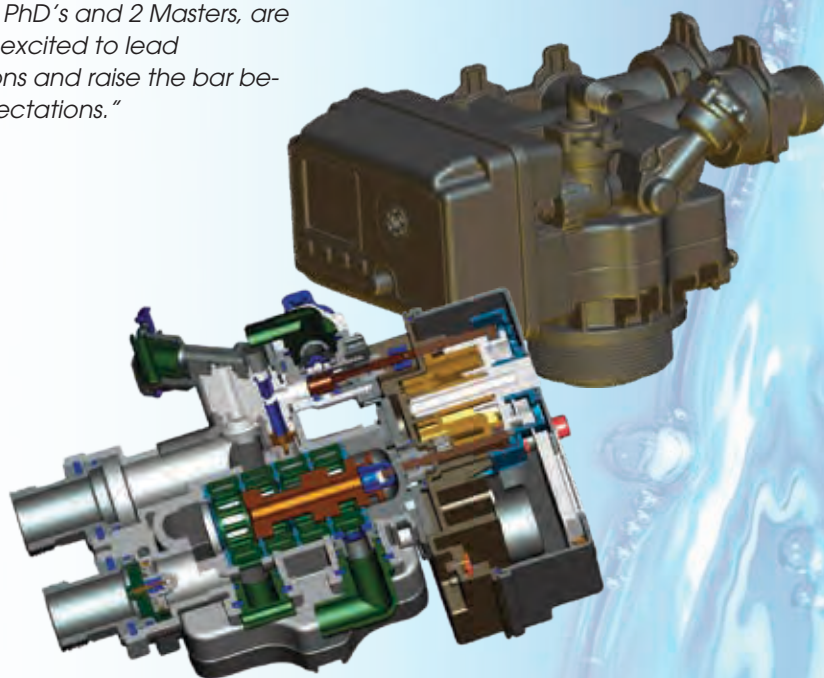

Control Valves

WaterGroup NSF/ANSI 44 Certified control valves meet or exceed the most vigorous industry performance and reliability standards. Familiar piston, seal and spacer design has been enhanced to improve performance and product life.

The addition of a piston stabilizer reduces the side load force between the piston rod and end plug seal as it firmly guides the piston while it travels up and down. An added rib on the seal improves the sealing pressure so that the valve can withstand over 700psi! These are just a few of the design features that make WaterGroup valves more reliable and better performing. Learn more about the 'Dealer-driven' control valve design features on page 15.

WaterGroup NSF/ANSI 44 Certified control valves meet or exceed competitive equivalents in all four key measures:
 1) Service Flow Rate, 2) Back Wash Flow Rate, 3) Burst Pressure and 4) Cycle Testing.

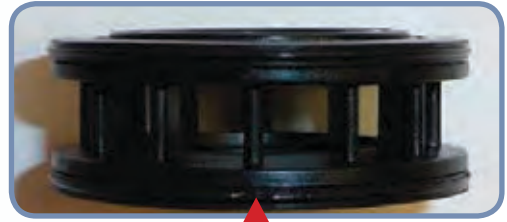

Added Rib Improves Seal



Piston Stabilizer

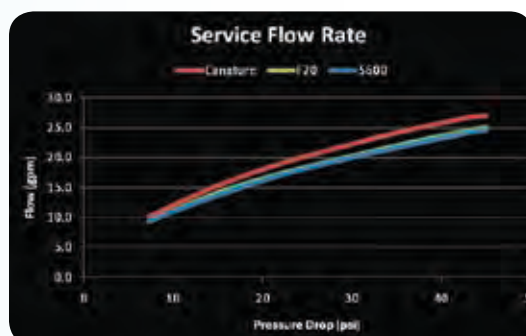
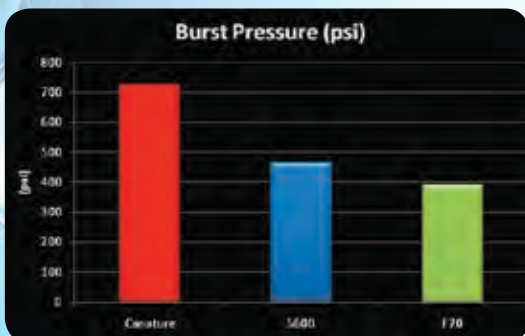
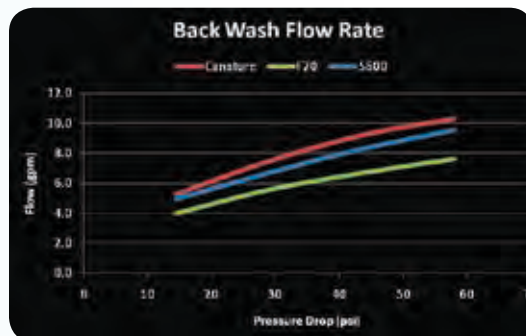

Fiberglass Tanks

WaterGroup NSF/ANSI 44 Certified filament wound tanks are not only strong and reliable but the finish is unparalleled in the industry. No need for a tank jacket (although we offer those too) with the neatly wound, high gloss finish. Strict tank height control measures mean no surprises when installing a duplex system.

The tanks are made in the World's first and only fully automated, robotic manufacturing process.

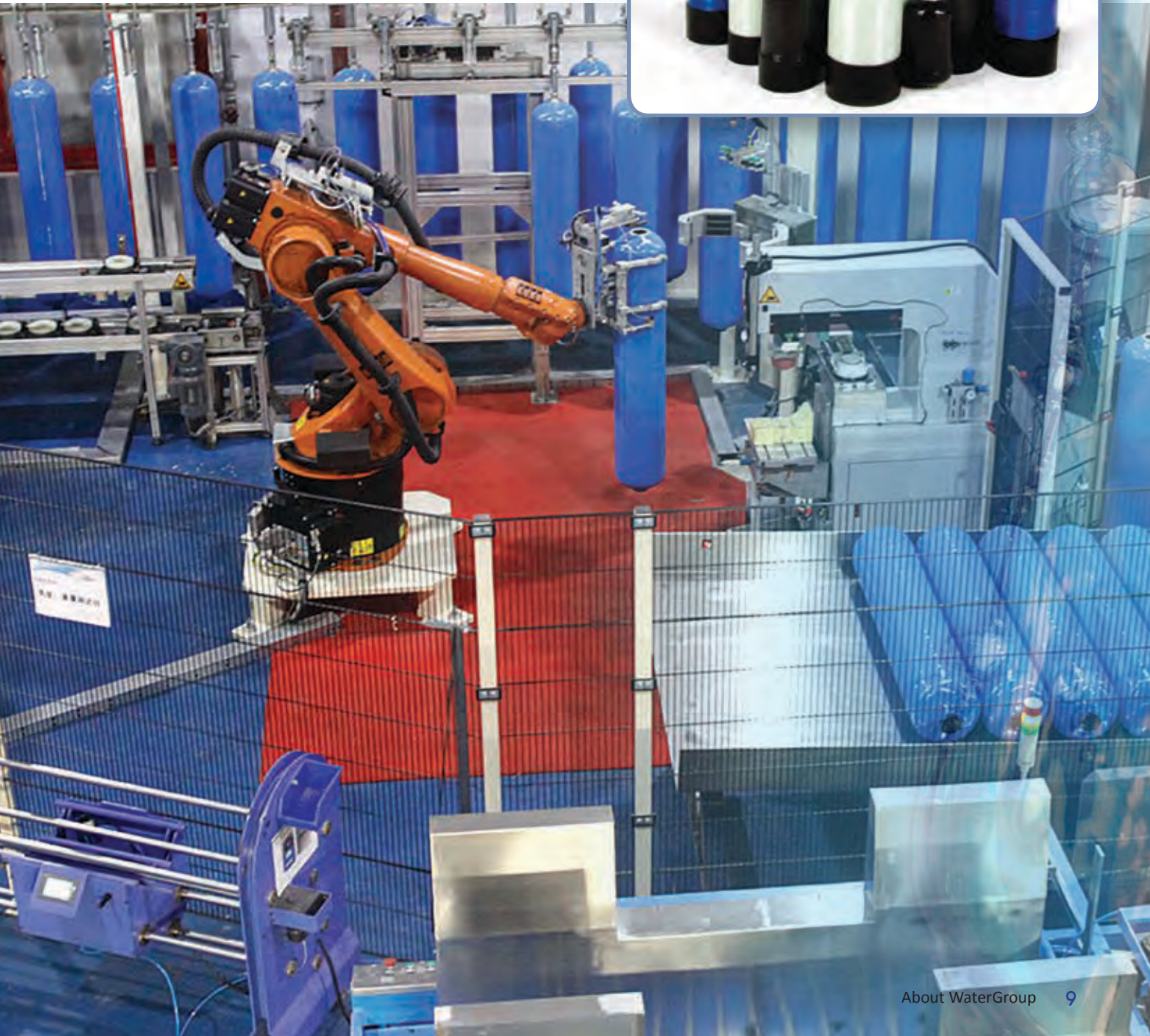

Assembly, Testing & Distribution

All water softeners and whole-house filters are engineered, assembled, tested and distributed from our North American Regional facilities. All control valves are 100% wet tested and air tested before leaving the factory. Control valves are then set up to engineering specifications for the particular unit, air tested a second time and then assembled into the finished product. All assembled products are packaged in durable, double walled high impact cardboard to ensure products arrive undamaged.



Mike Cummings assembling a softener in Regina, SK facility



Quality Assurance Department

WaterGroup employs a strict and formalized quality control program. The 925,000 sq. ft. Shanghai Manufacturing facility is ISO9001:2008 Quality Assurance and ISO 14001:2004 Environmental Management Systems standards certified.

Quality Control systems:

- ➔ Document Management
- ➔ Receiving Inspection
- ➔ In-process Quality Control
- ➔ Final Inspection
- ➔ Engineering Change Orders
- ➔ First Piece & Production Part Approval
- ➔ Test Equipment Calibration
- ➔ Statistical Process Control
- ➔ Vendor Quality Management
- ➔ Customer Feedback System



World Class Testing Laboratory

- ➔ **Burst Testing:** High pressure testing of tanks and valves to determine the maximum burst strength.
- ➔ **Cycle Pressure Testing:** High pressure cycling testing to simulate the fatigue strength of the tanks and valves over their life.
- ➔ **Flow Bench:** Precisely measure flow rates and pressure drops.
- ➔ **Reliability Testing:** Continuously cycling the valve through regeneration while taking flow measurements and counting the number of cycles.
- ➔ **Computer Aided Optical Comparator:** Used for precise measurement of very small details such as fillets or radius's.
- ➔ **Coordinate Measuring Machine (Cmm):** Used for precise geometrical x, y, and z measurement coordinates.
- ➔ **3d Prototype Printer:** Makes 3D models for rapid prototyping.
- ➔ **Chemical Analysis Laboratory:** Complete chemical analysis of raw materials including metals, plastics and media to ensure quality and integrity.



Water Conditioning Basics

The Hydrologic Cycle
Guidelines for Solving
Water Problems, Terminology,
Water Analysis,
Sizing Parameters



The Hydrologic Cycle

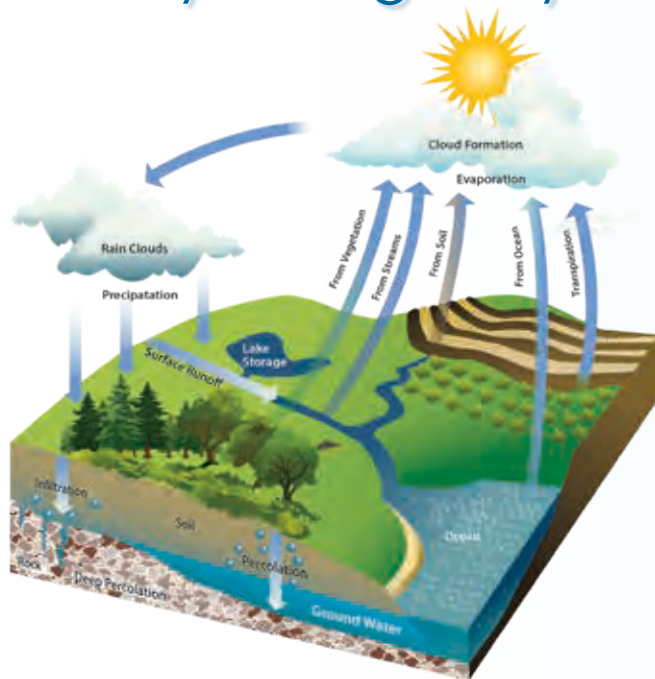

The total area of the earth is composed of 2/3 water, making it one of the most plentiful and most important materials available. Without potable water, mankind cannot survive.

Pure water consists of two parts hydrogen and one part oxygen, chemically combined to form pure water.

The only pure source of water is the earth's atmosphere (sometimes called the hydrological cycle). Impure water from the earth's oceans, lakes, rivers and surface evaporates into the atmosphere, then condenses to form rain droplets which are totally pure. The above process operates basically the same as a man-made still, which evaporates all the impurities from the water, then returns the condensates into pure water. If this process did not exist, there would likely not be enough potable water to support the earth's population.

“The only pure source of water is the earth's atmosphere.”

The pure water vapor, which forms in the earth's atmosphere (clouds), begins to pick up impurities. As it begins to fall to earth in the form of rain, snow, etc., impurities are immediately absorbed. These impurities may be dust, micro-organisms, gases, etc. - at least a little of everything found in the atmosphere on the way to the surface.

The rain or snowfall finds its way to various sources of water supplies on the earth's lakes, rivers, oceans or it may soak into the ground and become a part of an underground stream or lake.

Characteristics of Various Water Sources

Rain Water

After the water picks up impurities in the atmosphere and percolates through the ground, it comes into contact with carbon dioxide and then forms carbonic acid. This dissolves some of the mineral content of the soil or rock it contacts, thus adding these minerals to the water.

Surface Water

Water from streams may be turbid due to the presence of silt, clay, etc. However, in larger surface water, a greater amount of self-purification takes place through aerobic digestion, plant life, fish, etc. and the quality of the water could change to a great degree.

Ground Water

Normally picks up the minerals it flows through. As a general rule, water from deep wells contains a higher mineral content and is less likely to contain organics or turbidity. Water from shallow wells is usually lower in mineral content and may be subjected to pollution or other bacteria which is available from various sources nearby (e.g. spring run-off through forests and hills, plants, industrial wastes, etc. which will all pass various bacteria into the water).

Impurities

Impurities in water are divided into two classifications:

1. Dissolved Solids

Those which naturally dissolve into water. NOTE: Gases may also dissolve into water unless they combine chemically with other impurities. They will be released into the atmosphere upon boiling and are not truly classified as dissolved solids. Upon evaporation, only the dissolved solids would remain in the actual mineral form and then can be analyzed by actual weight of the various elements.

2. Suspended Solids

Consist of clay, mud, silt, etc. and will not dissolve into water naturally but remain as such in their present state.

Water treatment and pollution control is one of the largest and most important industries in the modern day world. As can be seen from the preceding information, water treatment is a very broad and varied field and chemical analysis of certain water supplies is virtually impossible to completely break down. In time, modern man may discover additional information regarding the field of water treatment and the entire cycle of the earth's largest and most important single resource.

The following sections will attempt to clarify some of the more common problems and solutions presently available.

Guidelines for Solving Water Problems

PROBLEM	SYMPTOM	CAUSE	CORRECTIVE EQUIPMENT
Hard Water	Spotting on dishes and glassware; scale on inside of water heater, pipes and water-using appliances; soap curd and bathtub ring; clothes look gray and dingy.	Calcium and magnesium in water, measuring 1.0 gpg or more.	Water Softener (Max. Hardness 100 gpg) (Max. Clear Water Iron 1.5 ppm)
Clear Water Iron (Ferrous)	Yellow, brown or rusty stains on plumbing fixtures, water-using appliances and fabrics; metallic taste in foods and beverages; water is clear when drawn from the faucet but oxidizes when exposed to air, then changes color ranging from yellow to brown.	Iron in the water measuring 0.3 ppm or more.	0.3-1.5 ppm Water Softener. 1.5-7.5 ppm SIM Specialty System Softener. 1.5-30 ppm Chemical Free Iron Filter (Note 1).
Red Water Iron (Ferric)	Same symptoms as Clear Water Iron but iron has already oxidized and has a yellow to rust color when drawn from the faucet.	Iron in the water measuring 0.3 ppm or more.	0.3-30 ppm Chemical Free Iron Filter (Note 1). 0.3-10 ppm Iron & Sulfur Filter.
Bacterial Iron	Same symptoms as Clear & Red Water Iron but can have clumps or balls that may foul plumbing lines and other water-using appliances; particularly noticeable as a yellow to reddish slime in toilet flush tanks.	Iron bacteria are a group of bacteria which thrive in ironbearing water, utilizing iron as an energy source. This bacteria is not a health hazard.	Chemical Free Iron Filter (Note 1). Chemical feed pump feeding chlorine followed by a Multimedia Filter (Note 3).
Manganese	Blackish stain on fixtures and laundry; manganese content above 0.05 ppm causes stains.	Interaction of carbon dioxide or organic matter with manganesebearing soils. Usually found in combination with iron.	0.05-1.0 ppm Chemical Free M Iron Filter (Note 1). 1.0-2.0 ppm Neutralizing Filter followed by Iron & Sulfur Filter (Note 2).
Acid Water	Blue/green or rusty stains and corrosion of plumbing fixtures and other water-using appliances; pitting of porcelain and enamel fixtures and dishes. Pin holes in copper plumbing lines.	Generally associated with water with a pH value of less than the neutral 7.0.	pH 6.0-6.9 Neutralizing Filter. pH 4.0-6.9 Chemical Feed Pump feeding soda ash. Consult our Customer Service Dept.
Aggressive/Corrosive Water	Same symptoms as Acid Water but pH is 7.0 or higher.	Alkalinity and carbon dioxide or high dissolved oxygen in water. Electrolysis - two dissimilar metals in plumbing lines.	Consult our Customer Service Dept.
Hydrogen Sulfide	Rotten egg taste and/or odor. Turns copper plumbing lines black. Very corrosive.	Hydrogen sulfide is a dissolved gas found in some water supplies.	0.1-3.0 ppm Chemical Free Iron Filter or Iron & Sulfur Filter. 3.0-15 ppm Chemical Feed Pump feeding chlorine followed by a Multimedia Filter (Note 3).
Marshy, metallic or chlorine taste and/or odors	Objectionable tastes and/or odors other than hydrogen sulfide.	Dissolved minerals or gases; organic contamination or chlorination.	Activated Carbon Filter for whole house water supply or Taste & Odor Cartridge Filter for individual faucets.
Turbidity (Sand/Sediment)	Foreign particles, dirty or cloudy water.	Tiny suspended particles that are the result of water main scale or silt. Private wells often contain sand or clay.	Multimedia Filter for whole house water supply or a Sediment Cartridge Filter for individual faucets.
Tannins	Yellow or brown tint or cast in water supply; tannins measuring 0.5 ppm or higher may cause staining and/or interference with various water treatment processes.	Result of decaying vegetative matter.	Organic Color Removal Filter. Consult our Customer Service Dept.

- Note 1** - Water must have a minimum pressure of 20 psi, pumping rate of 5 gpm and a pH of 6.5 or higher for proper operation. Most water supplies contain calcium and magnesium which are not removed by an iron filter. We recommend following an iron filter with a water softener.
- Note 2** - Oxidation of manganese is more pH dependent than iron. Therefore a pH of 8.2 or higher must be maintained. If the manganese level is >2.0 ppm or bacterial iron is present, consult our Customer Service Department.
- Note 3** - This system also requires a retention tank to allow adequate contact time (minimum 20 minutes). An optional activated carbon filter for the whole house water supply or a taste & odor cartridge filter for individual faucets may be installed to remove any objectionable taste or odor.

Terminology

Grains per Gallon - gpg

1/7000 of a pound - normally used in relation to hardness.

Parts per Million - ppm

One part dissolved material in one million parts of water. Used as a measurement for iron, manganese, TDS, hydrogen sulfide, chlorides, sulfates and tannins.

Milligrams per Liter - mg/l

For our purpose, same as ppm. Normally used for a more accurate measurement or where small quantities of certain elements cause big problems in relation to iron, manganese, sulfur, nitrates and silica.

Converting gpg to ppm or mg/l

1 gpg = 17.1 ppm (mg/l)

Total Dissolved Solids - TDS

The weight of solids, per unit volume of water, which are in true solution. Can be determined by the evaporation of a measured volume of filtered water and determination of the residue weight. A common alternative method to determine TDS is to measure the conductivity of water.

Hardness

A characteristic of natural water due to the presence of dissolved calcium and magnesium. Water hardness is responsible for most scale formation in pipes and water heaters and forms insoluble "curd" when it reacts with soaps. Hardness is usually expressed in grains per gallon (gpg), parts per million (ppm) or milligrams per liter (mg/l), all as calcium carbonate equivalent.

Ferric Iron

Iron that is oxidized in water and is visible. Also called red water iron.

Ferrous Iron

Iron that is dissolved in water. Also called clear water iron.

pH

pH is a measure of the intensity of the acidity or alkalinity of water on a scale from 0 to 14, with 7 being neutral. When acidity is increased, the hydrogen ion concentration increases, resulting in a lower pH value. Similarly, when alkalinity is increased, the hydrogen ion concentration decreases, resulting in higher pH.

The pH value is an exponential function so that pH 10 is 10 times more alkaline than pH 9 and 100 times more alkaline than pH 8. Similarly, a pH 4 is 100 times more acid than pH 7.

pH Scale

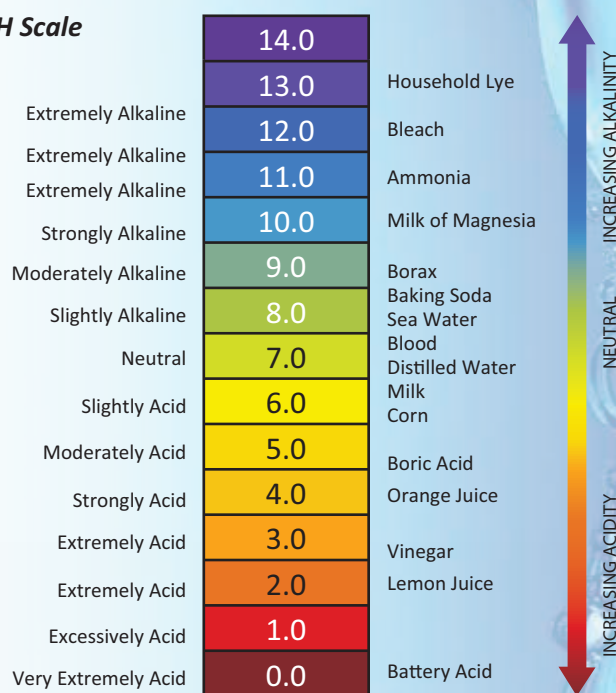

Note: A complete glossary can be found in the Water Conditioning Glossary section.

Water Analysis

For correct sizing and application of water conditioning equipment, a water analysis is required. A basic water analysis includes tests for the following:

- **Hardness**
- **Iron**
- **Manganese**
- **pH**
- **TDS (Total Dissolved Solids)**

Water samples should be taken as near the source as possible and represent the average water condition. Clean containers must be used. When performing the analysis, the test equipment must be clean and rinsed with the test water and the test water should be between 68°F and 77°F (20°C and 25°C). Use rubber stops as supplied. Do not use your fingers as contaminants and acids could affect test results.

Additional tests can be performed for tannins and hydrogen sulfide (H₂S). The test for H₂S must be performed on-site for accurate results. Special tests can be performed for chlorides, sulfates and alkalinity by specified laboratories. If it is suspected the water supply is contaminated with coliform bacteria or nitrates, a sample must be collected in an approved sterilized container and submitted to a government approved laboratory. Iron bacteria will not be detected with the standard iron test and can be tested for by a government approved laboratory.

If the TDS is over 1000 ppm and hardness is less than 30% of the TDS, a complete water analysis should be performed to discover what other contaminants exist in the water.

If a contaminant exceeds the limits detectable by any test method, the raw water sample can be diluted with distilled water until a reading can be taken. A calculation must then be performed to determine the actual degree of contamination. All test chemicals are subject to age and extreme temperatures. Proper storage techniques and expiry dates should be observed.

The Water Analysis Report shown on the next two pages must be completed accurately to determine the correct equipment to recommend for the water problem(s) being experienced.

Hard Water

Water with a total hardness of 1.0 gpg or more as calcium carbonate equivalent.

Less than 1.0 gpg	Soft
1.0 - 3.5 gpg	Slightly hard
3.5 - 7.0 gpg	Moderately hard
7.0 - 10.5 gpg	Hard
More than 10.5 gpg	Very hard

Hardness

A characteristic of natural water due to the presence of dissolved calcium and magnesium. Water hardness is responsible for most scale formation in pipes and water heaters and forms insoluble "curd" when it reacts with soaps. Hardness is usually expressed in grains per gallon (gpg), parts per million (ppm) or milligrams per liter (mg/l) all as calcium carbonate equivalent.

Soft Water

Any water which contains less than 1.0 gpg (17.1 mg/l) of hardness minerals, expressed as calcium carbonate equivalent.

Softened Water

Any water that is treated to reduce hardness minerals, expressed as calcium carbonate equivalent.

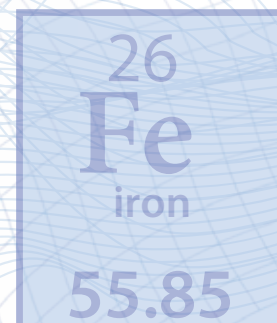
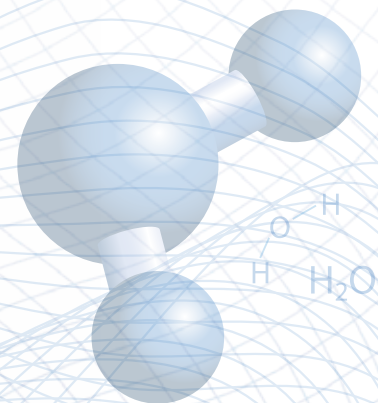
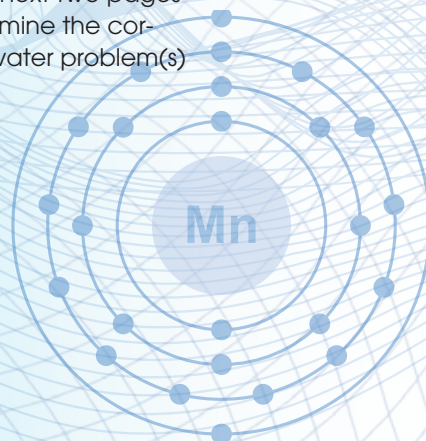

Date Received _____

Report No. _____

Date Completed _____

Water Analysis Report

NOTE: Please answer ALL appropriate questions to ensure accurate equipment recommendations

CUSTOMER

DEALER

DISTRIBUTOR

Name _____

Name _____

Name _____

Street _____

Street _____

Street _____

Town _____ State/Province _____

Town _____ State/Province _____

Town _____ State/Province _____

Zip Code/P.C. _____ Email _____

Zip Code/P.C. _____ Email _____

Zip Code/P.C. _____ Email _____

Phone _____

Phone _____

Phone _____

Analysis for Bacteria, Arsenic, Lead and other heavy metals must be performed by your local health department or an independent laboratory.

HOW TO DRAW WATER SAMPLE

Use outlet nearest pump (not from bottom of pressure tank). Run water for five minutes or two pump cycles, then fill clean bottle to neck and cap immediately. Never use hot water. Return bottle with this completed form.

HOW TO MEASURE PUMPING RATE OF PUMP

1. Make certain no water is being drawn. Open spigot nearest pressure tank. When pump starts, close tap and measure time (in seconds) to refill pressure tank. This is **cycle time**.
2. Using a container of known volume, draw water and measure volume in gallons until pump starts again. This is **drawdown**.
3. Divide drawdown by cycle time and multiply the result by 60 to arrive at the **pumping rate** in gallons per minute. Insert this figure in #3 Water System.

1. Water Source

- City or area-wide authority
- Community water system (small water system usually supplying 12 homes or fewer) Water comes from:
- Well Lake Reservoir River Unknown
- New private well - Approx age: _____ months
- Depth of Well:** _____
- Old private well - Approx age: _____ months
- Private lake Private spring Private dugout Other - describe: _____

2. Household Information

- Do you now have water conditioning equipment?
- No Yes Type: _____ Size: _____
- Single family Multi-family No. of units: _____
- No. persons: _____ No. baths: _____
- Do baths have high flow demand? No Yes
- Lawn irrigation on water system? Indoor pool
- Outdoor pool - Capacity: _____ gallons
- Water line size from source: _____ inches

3. Water System

Type of Pump

- Constant Pressure Jet Submersible Unknown
- Pumping rate of pump: _____ gpm

Pressure Tank

- Air to water Bladder Capacity: _____ gallons
- Operating pressure: (low/high) _____ / _____ psi.

4. Water Problems

When this sample was drawn, it was:

- Clear Colored Cloudy

This water sample is Untreated Treated

How is it treated? (List Brand and Model #'s): _____

PROBLEMS

- Hardness (e.g. high soap usage, bathtub ring, lime deposits, etc.)
- Iron Deposits - if so, is iron build-up in flush tank?
- Greasy Gritty Stringy (iron bacteria?)
- Color of Water - Red Orange Black
- Greenish or blue stains on sinks, tubs, etc.
- Pitting of fixtures and/or pipes
- Sand (visible particles) Sediment or silt (cloudy)
- Bad Taste - Iron Bitter Salty
- Other - describe: _____

Bad Odor: Rotten Egg Musty Iron

Odor is in: Cold Water Hot Water Both

Other Problems - describe: _____

5. Standard Laboratory Tests

Total Hardness: _____ gpg
Iron: _____ mg/l
Manganese: _____ mg/l
pH: _____
Total Dissolved Solids: _____ mg/l

6. Other Tests

Hydrogen Sulfide: _____ mg/l
(test must be performed on-site)
Tannins: _____ mg/l

If TDS is over 1000 ppm and hardness is less than 30% of the TDS, a total water analysis is required.

7. Explanation of Water Analysis

A. Total Hardness

This indicates the efficiency or workability of the water for everyday household use. Water in excess of 3 gpg is generally considered hard and should be softened.

B. Iron

Over 0.3 ppm of iron will cause discoloration of water and staining. Fully automatic water conditioners will correct this problem. Some extreme water situations may require filtration.

C. Manganese

Manganese is frequently encountered in iron-bearing water but to a lesser degree. Manganese is similar to iron in that it stains and clogs pipes and valves. Concentrations as low as 0.05 mg/l of manganese can cause problems.

D. pH

A scale used to measure the acidity or alkalinity of water. A pH reading below 6.5 normally indicates highly corrosive water and neutralizing equipment should be used. A pH reading in excess of 8.5 could indicate contaminated water and generally requires bacteriological and chemical analysis.

E. Hydrogen Sulfide (H₂S)

Testing for hydrogen sulfide should occur on-site. Hydrogen sulfide imparts a rotten egg odor and taste that makes water all but undrinkable and also promotes corrosion. In addition, it can foul the resin bed of a water conditioner. The use of a water conditioner is not recommended unless the water is first treated for the removal of hydrogen sulfide.

F. Total Dissolved Solids (TDS)

A measure of the soluble solids present in the water.

G. Tannins

Tannic acid is formed by decaying organic matter. Tannins alone are not harmful, although they can affect the proper operation of a chemical free iron filter.

RECOMMENDATIONS

Recommendations are based entirely on the information supplied and the water sample chemistry results at the time of analysis.

Recommended by: _____

Date: _____

Return completed form to:

Sizing Parameters

Water Softener Sizing is Based On

- ➔ 60 gallons per person per day - total household use
- ➔ Three day minimum between regenerations
- ➔ Capacity between regenerations at factory salt settings
- ➔ Number of people x 60 gallons per person x gpg of hardness x 3 days = capacity required between regenerations
- ➔ Consult your factory representative for water that is 75 gpg or harder

Water Softener/Iron Removal Combination Units

- ➔ This unit should be recommended only when dictated by special circumstances or the needs of the customer.
- ➔ The customer should be made aware that a separate iron filter and softener is preferred because it is a more efficient way to deal with the water.
- ➔ When recommending a combination unit, follow the guidelines provided in the specifications.

Water Consumption for Regeneration

The volume of water used during the regeneration process of a water softener will vary depending on:

- ➔ Amount and type of resin
- ➔ Cycle time settings
- ➔ Flow controllers
- ➔ Salt settings
- ➔ Tank diameter

Generally, water usage for regeneration is based on the cubic feet of resin per water softener from a low of 30 gallons of water per cubic foot, up to a normal of 75 gallons of water per cubic foot, to a maximum of 100 gallons of water per cubic foot. Manufacturing specs and settings for each model size should be checked to verify exact amounts.

Three Day Sizing Method

The three day sizing method is used for the following reasons:

1. To determine the size of the water conditioner to be used
2. To allow for reserve capacity between regenerations so the customer does not run out of soft water
3. To provide the most economical operation cost

Conversion Factors & Compensated Iron & Manganese

Total Hardness converted from ppm or mg/l to Grains/US Gallon (gpg)

$$\text{ppm (mg/l)} \div 17.1 = \text{gpg}$$

If there is a small amount of Iron or Manganese in the water, add the following compensated values:

Iron - ppm x 4

Manganese - ppm x 8

To arrive at the additional compensated load on the softener

The Total Equivalent Iron for the softener to remove should not be greater than 1.5 ppm. Total Equivalent Iron is calculated as follows:

$$\text{Iron ppm} + 2 \times \text{Manganese ppm} < 1.5 \text{ ppm}$$

If the Total Equivalent Iron is less than 0.5 ppm, a Res-Up Feeder and Pro ResCare can be added as an optional safeguard against fouling or the bed can be cleaned occasionally by adding a small amount to the brine tank manually.

If the Total Equivalent Iron is 0.5 - 1.5 ppm, the softener can be sized accordingly but a Res-Up Feeder and Pro ResCare is required in addition to the softener to prevent iron fouling of the resin.

If the Total Equivalent Iron is greater than 1.5 ppm, an Iron Filter is required as pretreatment prior to the softener.





**Softeners, Filters
& Specialty Systems**

Unique Features Designed with the Plumber in Mind

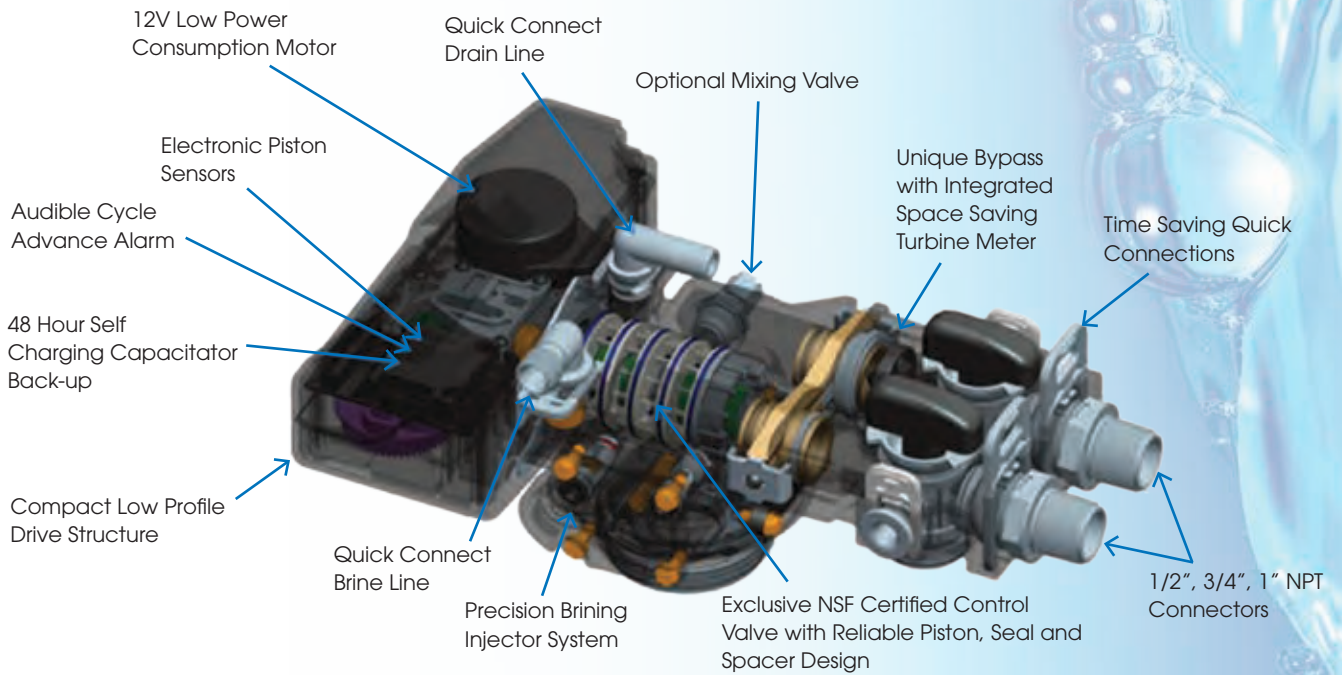

Quick Connect Features for Ultimate Convenience

The quick connect bypass comes with both 3/4" 90 degree elbows and 1" straight NPT adaptors. Optional quick connect adaptors include 3/4" straight SharkBite and 3/4" NPT adaptors.



All units include pre-installed bypass



Standard QC Fittings



Optional Fittings



New Quick Connect Stainless Steel Flexi-Connector Kits

Two 18" flexible water connectors with 3/4" John Guest® Quick Connect fittings and proprietary bypass valve connection for all Canature WaterGroup manufactured water softeners and whole-house filters. Excludes 89 1" Control Valve Series.

Space Saving Improved Design

Eliminate 4" and unnecessary connections for neat, quick installations. Bypass with integrated meter avoids 'meter jamming' which is caused from weight of pipes creating torque on turbines causing them to bind and stop metering.

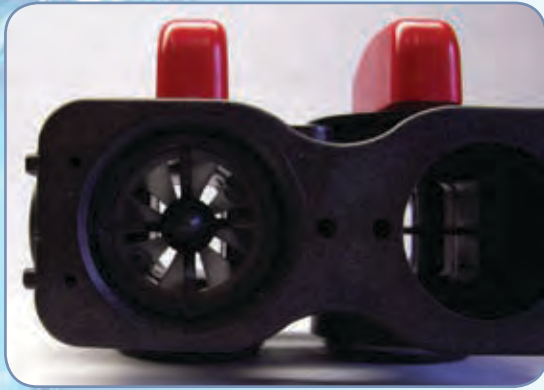

integrated meter in bypass

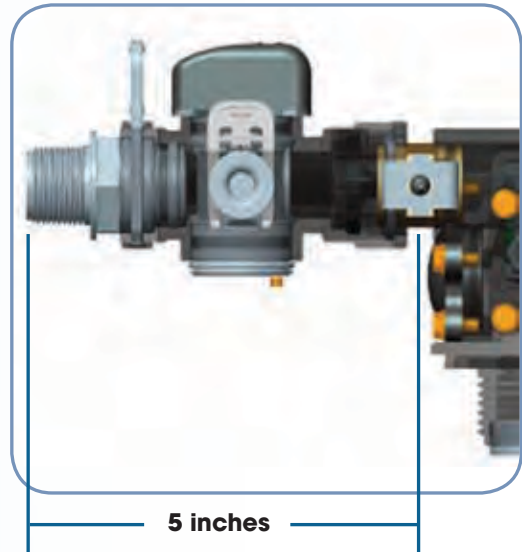

1 Connection Comes pre-installed



QC Power Cable

- Simplifies installation or removal of the valve from the tank
- No tangled or wrapped up power cords!

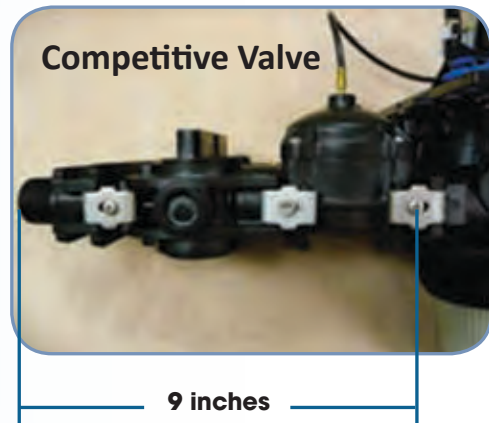

3 Connections

High Quality Brine Components

- Closed bottom brine well reduced intrusion of unwanted impurities
- Injection molded brine grids reduce bridging
- Solvent free distributor tube with spun weld collector avoids glue and solvents
- Injection molded reliable brine valve

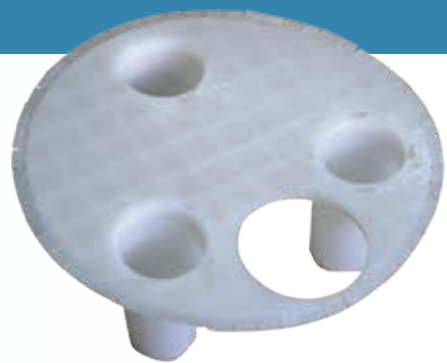

Heavy Duty Packaging

WaterGroup uses only durable double-walled high impact cardboard with carrying straps to ensure you do not have to deal with the headache of receiving damaged products.



"Our focus is to build the highest quality water conditioning products in the industry... so when it comes to protecting them from damage during shipping & handling we don't 'cheap out'"

Toby Hughes, P.Eng
Chief operations officer

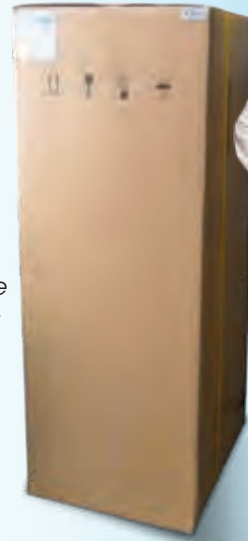

Water Softener Sizing Guide

Choosing the Right Size Softener

# of People	Total Hardness (Grains per Gallon)									
	10	15	20	25	30	40	50	60	70	75
1	WG185 24 EFT20	WG185 24 EFT20	WG185 24 EFT20	WG185 24 EFT20	WG185 24 EFT20	WG185 32 EFT30	WG185 32 EFT30	WG185 40 EFT40	WG185 40 EFT40	WG185 40 EFT40
2	WG185 24 EFT20	WG185 24 EFT20	WG185 24 EFT20	WG185 24 EFT20	WG185 24 EFT20	WG185 32 EFT30	WG185 32 EFT30	WG185 40 EFT40	WG185 40 EFT40	WG185 40 EFT60
3	WG185 24 EFT20	WG185 24 EFT20	WG185 24 EFT20	WG185 24 EFT20	WG185 24 EFT20	WG185 32 EFT30	WG185 40 EFT60	WG185 60 EFT60	WG185 60 EFT60	WG185 60 EFT60
4	WG185 24 EFT20	WG185 24 EFT20	WG185 24 EFT20	WG185 24 EFT30	WG185 32 EFT30	WG185 40 EFT60	WG185 60 EFT60	WG185 60 EFT90	WG185 90 EFT90	WG185 90 EFT90
5	WG185 24 EFT20	WG185 24 EFT20	WG185 32 EFT30	WG185 32 EFT40	WG185 40 EFT60	WG185 60 EFT60	WG185 60 EFT90	WG185 90 EFT90	WG185 90 EFT90	WG185 90
6	WG185 24 EFT20	WG185 24 EFT30	WG185 32 EFT40	WG185 40 EFT60	WG185 60 EFT60	WG185 60 EFT90	WG185 90 EFT90	WG185 90 EFT90	WG185 HEDP 90	Call for Sizing
7	WG185 24 EFT20	WG185 24 EFT30	WG185 40 EFT40	WG185 60 EFT60	WG185 60 EFT60	WG185 60 EFT90	WG185 90 EFT90	WG185 HEDP 90	Call for Sizing	Call for Sizing
8	WG185 24 EFT20	WG185 32 EFT30	WG185 40 EFT60	WG185 60 EFT60	WG185 60 EFT60	WG185 90 EFT90	WG185 90	Call for Sizing	Call for Sizing	Call for Sizing
9	WG185 24 EFT30	WG185 40 EFT40	WG185 60 EFT60	WG185 60 EFT60	WG185 90 EFT90	WG185 90 EFT90	WG185 HEDP 90	Call for Sizing	Call for Sizing	Call for Sizing
10	WG185 32 EFT30	WG185 40 EFT60	WG185 60 EFT60	WG185 60 EFT90	WG185 90 EFT90	WG185 HEDP 90	Call for Sizing	Call for Sizing	Call for Sizing	Call for Sizing

Notes:

We recommend contacting Novo Water Customer Service for any hardness levels above 75 gpg for proper recommendations
Cabinet models are available for all 75 and 100 models

WG185UF Series Water Softener

High-Efficiency Performance



Removable brine tank with sliding salt lid



7 Year Warranty Control Valve



Lifetime Warranty Pressure tank





IAPMO R & T Certified against CSA B483.1

Features:

- Exclusive WG 185UF NSF Certified electronic control valve with reliable piston, seal and spacer technology
- Cabinet or Twin Tank models
- User-friendly backlit LCD display
- "No Touch" information display rotates key info like last regeneration date and volume remaining
- 48 hour memory back-up
- Meter Immediate, Meter Delayed, Meter Override, and Calendar Clock mode
- Adjustable cycle times
- Brine safety valve provides extra overflow protection
- Unique bypass with an integrated space saving turbine meter and sample ports on the inlet. One-piece design avoids meter jamming.
- Time saving quick connect fittings on bypass, drain and brine line. Power cord even has quick connect for easy valve spin on.
- Drain line o-ring eliminates need for Teflon
- Condensation tank jacket (twin tank models)
- Hose clamp and 10' of drain tubing included
- IAPMO Tested and Certified against CSA B483.1

All Systems Include:

- ▶ **NSF Certified** pressure tank 
- ▶ **NSF Certified** control valve 
- ▶ **IAPMO Certified** cation resin
- ▶ **Pre-installed** bypass
- ▶ **Injection molded** brine grids (twin tanks only)

*Compared to conventional calendar clock models

Injection molded brine grid reduces bridging



High Performance Features:



Reverse Flow Regeneration with Precision Brining

Traditional 'downflow' softeners deplete the unused portion of the resin bed with every regeneration. It is like draining the gas tank in your car every time before filling it up!

'Reverse Flow Regen' - drives the hardness minerals up through the already depleted resin and out to drain - saving both salt and the unused portion of the resin for future use.

Precision Brining - saves additional salt by pre-making only 70% of the brine. Just before regeneration, the computer calculates the precise amount of brine top-up needed to regenerate only the depleted resin saving up to 30% more salt!



- ▶ **Municipal Backwash Cycle Preset** reduces back wash frequency for clean water supplies →
- ▶ **Sanitary System Flush** flushes stagnant water after 7 days of non-use preventing bacteria growth
- ▶ **Soft Water Quick Charge Mode** ensures soft water during unusually heavy water usage
- ▶ **Soft Water Brine Tank Refill** keeps tank & injectors clean

Estimated Annual Back Wash Water Usage

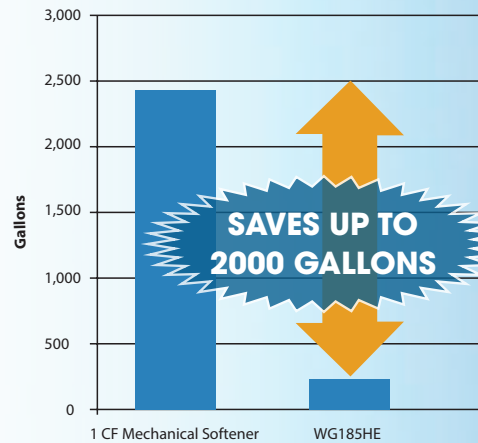

ULTIMATE SALT & WATER SAVINGS!

Use 75% Less Salt & 64% Less Water! It's good for you & good for the environment!

Salt Used Per Year

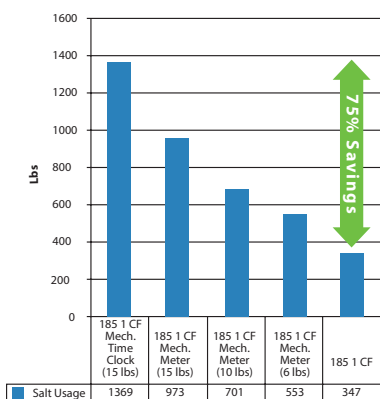

Estimated Regeneration Water Used Per Year

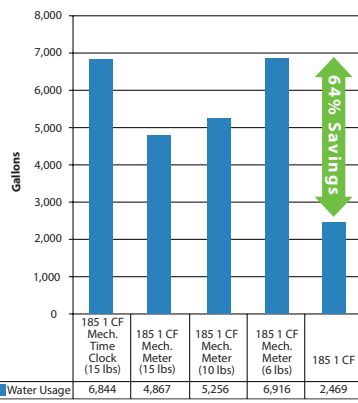

Estimated Annual Operating Cost (Salt + Water)

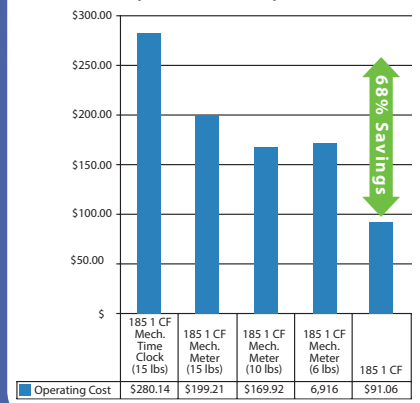

185 Water Softener Specifications

Specifications	WG185UF24C	WG185UF32C	WG185UF24	WG185UF32	WG185UF40	WG185UF60	WG185UF90
	2130	2131	2132	2133	2134	2135	2136
Optional Settings - High Efficiency							
Salt Used - Per Regeneration	2.3 lbs	3.0 lbs	2.3 lbs	3.0 lbs	3.75 lbs	6.0 lbs	9.0 lbs
Water Used - Regeneration	22.7 gal	28.3 gal	22.6 gal	31.6 gal	39.5 gal	60.9 gal	102.2 gal
Hardness Removal - Grains	11,250	15,000	11,250	15,000	18,750	30,000	45,000
Factory Settings - Standard Capacity							
Salt Used - Per Regeneration	4.5 lbs	6.0 lbs	4.5 lbs	6.0 lbs	7.5 lbs	12.0 lbs	18.0 lbs
Water Used - Regeneration	40.5 gal	48.6 gal	34.0 gal	43.4 gal	54.3 gal	87.1 gal	139.2 gal
Hardness Removal - Grains	18,750	25,000	18,750	25,000	31,250	50,000	75,000
Optional - High Capacity							
Salt Used - Per Regeneration	7.5 lbs	10.0 lbs	7.5 lbs	10.0 lbs	12.5 lbs	20.0 lbs	30.0 lbs
Water Used - Regeneration	56.1 gal	69.5 gal	49.6 gal	64.3 gal	80.37 gal	124.6 gal	196.2 gal
Hardness Removal - Grains	22,500	30,000	22,500	30,000	40,000	60,000	90,000
Resin Quantity - Cubic Feet	0.75 ft	1.0 ft	0.75 ft	1.0 ft	1.25 ft	2.0 ft	3.0 ft
Tank Size	9x35	10x35	9x35	10x35	10x47	12x52	14x65
Tank Jacket / Media Loaded	Yes	Yes	Yes	Yes	Yes	No	No
Brine Tank / Cabinet Size (Inches)	19.6 x 13.7 x 43.7	19.6 x 13.7 x 43.7	18.1 x 34.5	18.1 x 34.5	18.1 x 34.5	20.3 x 37.4	23.0 x 40.5
Salt Storage Capacity	175 lbs	175 lbs	240 lbs	240 lbs	240 lbs	350 lbs	420 lbs
Flow Rate @ 15 psi Pressure Drop	11.6 gpm	12.0 gpm	10.4 gpm	11.0 gpm	12 gpm	12.2 gpm	12.6 gpm
Flow Rate @ 25 psi Pressure Drop	15.6 gpm	16.0 gpm	14.3 gpm	15.0 gpm	15.5 gpm	16.2 gpm	16.6 gpm
Back Wash Flow Rate	2.0 gpm	2.4 gpm	1.5 gpm	2.0 gpm	2.4 gpm	3.5 gpm	5.0 gpm
Shipping Weight	93 lbs	110 lbs	105 lbs	122 lbs	154 lbs	172 lbs	244 lbs
Regeneration Type	Counter Current / Up Flow						
Maximum Efficiency	5,060 grains /lb salt						
Plumbing Connections	Includes 3/4" 90° Elbows & 1" Straight NPT						
Resin Type	Canature 8% High Capacity Ion Exchange Resin						
Electrical Requirements	Input 120V 60 Hz - Output 12V 650mA						
Water Temperature	Min 39 - Max. 100 degrees Fahrenheit						
Water Pressure	Min. 20 - Max. 125 psi						

WG185DF Series Water Softener



Mid Efficiency with Added Features

Offers a balance of technology and features at a great price point. User-friendly backlit LCD display with "No Touch" information display



* Compared to conventional calendar clock models

All Systems Include:

- ▶ **NSF Certified** pressure tank 
- ▶ **NSF Certified** control valve 
- ▶ **IAPMO Certified** cation resin



Features:

- Exclusive WG 185DF NSF Certified electronic control valve with reliable piston, seal and spacer technology
- Cabinet or Twin Tank models
- User-friendly backlit LCD display
- "No Touch" information display rotates key info like last regeneration date and volume remaining
- 48 hour memory back-up
- Meter Immediate, Meter Delayed, Meter Override, and Calendar Clock mode
- Adjustable cycle times
- Brine safety valve provides extra overflow protection
- Unique pre-installed bypass with an integrated space saving turbine meter and sample ports on the inlet. One-piece design avoids meter jamming.
- Time saving quick connect fittings on bypass, drain and brine line. Power cord even has quick connect for easy valve spin on.
- Drain line o-ring eliminates need for Teflon
- Condensation tank jacket (twin tank models)
- Injection molded brine grids (twin tanks only)
- Hose clamp and 10' of drain tubing included
- IAPMO Tested and Certified against CSA B483.1



7 Year Warranty Control Valve





Lifetime Warranty Pressure tank

Specifications	WG185DF24C	WG185DF32C	WG185DF24	WG185DF32	WG185DF40	WG185DF60	WG185DF90
	2110	2111	2113	2113	2114	2115	2116
Optional Settings - High Efficiency							
Salt Used - Per Regeneration	2.3 lbs	3.0 lbs	2.3 lbs	3.0 lbs	3.75 lbs	6.0 lbs	9.0 lbs
Water Used - Regeneration	22.7 gal	28.3 gal	22.6 gal	31.6 gal	39.5 gal	60.9 gal	102.2 gal
Hardness Removal - Grains	11,250	15,000	11,250	15,000	18,750	30,000	45,000
Factory Settings - Standard Capacity							
Salt Used - Per Regeneration	4.5 lbs	6.0 lbs	4.5 lbs	6.0 lbs	7.5 lbs	12.0 lbs	18.0 lbs
Water Used - Regeneration	40.5 gal	48.6 gal	34.0 gal	43.4 gal	54.3 gal	87.1 gal	139.2 gal
Hardness Removal - Grains	18,750	25,000	18,750	25,000	31,250	50,000	75,000
Optional - High Capacity							
Salt Used - Per Regeneration	7.5 lbs	10.0 lbs	7.5 lbs	10.0 lbs	12.5 lbs	20.0 lbs	30.0 lbs
Water Used - Regeneration	56.1 gal	69.5 gal	49.6 gal	64.3 gal	80.37 gal	124.6 gal	196.2 gal
Hardness Removal - Grains	22,500	30,000	22,500	30,000	40,000	60,000	90,000
Resin Quantity - Cubic Feet	0.75 ft	1.0 ft	0.75 ft	1.0 ft	1.25 ft	2.0 ft	3.0 ft
Tank Size	9x35	10x35	9x35	10x35	10x47	12x52	14x65
Tank Jacket / Media Loaded	Yes	Yes	Yes	Yes	Yes	No	No
Brine Tank / Cabinet Size (Inches)	13.7 x 23.6 x 43.3	13.7 x 23.6 x 43.3	18.1 x 34.5	18.1 x 34.5	18.1 x 34.5	20.3 x 37.4	23.0 x 40.5
Salt Storage Capacity	175 lbs	175 lbs	240 lbs	240 lbs	240 lbs	350 lbs	420 lbs
Flow Rate @ 15 psi Pressure Drop	11.6 gpm	12.0 gpm	10.4 gpm	11.0 gpm	12 gpm	12.2 gpm	12.6 gpm
Flow Rate @ 25 psi Pressure Drop	15.6 gpm	16.0 gpm	14.3 gpm	15.0 gpm	15.5 gpm	16.2 gpm	16.6 gpm
Back Wash Flow Rate	2.0 gpm	2.4 gpm	1.5 gpm	2.0 gpm	2.4 gpm	3.5 gpm	5.0 gpm
Shipping Weight	93 lbs	110 lbs	105 lbs	122 lbs	154 lbs	172 lbs	244 lbs
Regeneration Type	Co Current / Down Flow						
Plumbing Connections	Includes 3/4" 90° Elbows & 1" Straight NPT						
Resin Type	Aquafine 8% High Capacity Ion Exchange Resin						
Electrical Requirements	Input 120V 60 Hz - Output 12V 650mA						
Water Temperature	Min 39 - Max. 100 degrees Fahrenheit						
Water Pressure	Min. 20 - Max. 125 psi						

EconoFlo Series Water Softener

The economical and reliable EconoFlo Series Water Softener offers simple electronics for the same price as mechanical metered units. Offer your customers more for less. Manually index cycle position for easier, faster installation and service.

Features:

- ▶ **Exclusive WaterGroup NSF Certified** electronic control valve with reliable piston, seal and spacer technology 
- ▶ **Manual index dial** for quick manual regeneration or cycle position selection
- ▶ **Simple electronics:** just set time of day, hardness and number of people
- ▶ **Control valve** also offers 48 hour memory back up, adjustable cycle times and optional regeneration modes (Meter Immediate, Meter Delayed, Meter Override, Calendar Clock)
- ▶ **IAPMO Tested** and Certified against CSA B483.1
- ▶ **NSF Certified** Pressure Tank 
- ▶ **IAPMO** approved cation exchange resin
- ▶ **Available in** traditional twin tank or compact cabinet design
- ▶ **Factory installed** one piece meter-in-bypass saves installation time and space
- ▶ **Quick connect fittings** on bypass, drain line, brine line and power cord for faster easier installations. Drain line o-ring eliminates need for Teflon.



*Compared to conventional calendar clock models



5 Year Warranty Control Valve



10 Year Warranty Pressure tank

Simpler than setting your alarm clock!

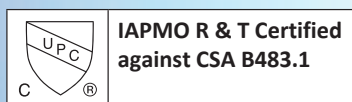

Model Number	Item Number	Capacity - Grains			Flow Rate		Mineral Tank Size (Inches)	Total Resin (cu. ft.)	Cabinet or Brine Tank Size Inches (WXDXH)	Salt Capacity (lbs)	Shipping Weight (lbs)
		@ 10 lbs/cu ft	@ 6 lbs/cu ft Factory Setting	@ 3 lbs/cu ft	Service USGPM	Backwash USGPM					
EFC20	2117	19,875	16,500	10,500	8	2	9 X 35	0.75	13.8 X 23.6 X 34.5	225	93
EFC30	2118	26,500	22,000	14,000	10	2.4	10 X 35	1	13.8 X 23.6 X 34.5	225	110
EFT20	2119	19,875	16,500	10,500	8	2	9 X 35	0.75	18.1 X 34.5	230	93
EFT30	2120	26,500	22,000	14,000	10	2.4	10 X 35	1	18.1 X 34.5	230	110
EFT40	2121	33,125	27,500	17,500	12	2.4	10 X 47	1.25	18.1 X 34.5	230	141
EFT60	2122	53,000	44,000	28,000	13	3.5	12 X 52	2	20.3 X 37.4	270	158
EFT90	2123	79,500	66,000	42,000	15	5	14 X 65	3	23.0 X 40.5	700	244
Regeneration Type		Co current / Down Flow									
Plumbing Connections		Includes 3/4" 90°Elbows & 1" Straight NPT									
Resin Type		Aquafine 8% High Capacity Ion Exchange Resin									
Electrical Requirements		Input 120V 60 Hz - Output 12V 650mA									
Water Temperature		Min 39 - Max. 100 degrees Fahrenheit									
Water Pressure		Min. 20 - Max. 125 psi									

85 TA 1" Series Water Softener

Our **85 TA 1" (Twin Alternating) Series** softeners provide up to 16.6 gpm of continuous soft water 24 hours a day. They are engineered and thoroughly tested to provide years of reliable, trouble free performance with minimal maintenance.

Operating Parameters

- ➔ Operating pressure: 20 - 100 psi
- ➔ Operating temperature: 39 - 100° F
- ➔ Electrical: Input 120V 60 Hz - Output 12VAC 650mA

Materials of Construction

- ➔ Control Valve: Plastic PPO (Noryl)
- ➔ Resin Tanks: Corrosion resistant fibreglass reinforced polyethylene NSF 44 Certified
- ➔ Brine Tank: High density polyethylene (includes plastic salt plate, brine well & cap, air check, and safety float)
- ➔ Ion Exchange Resin: High Capacity WQA certified 8% Canature resin
- ➔ Internal Distributors

Standard Features

- ➔ Up-flow: Provides high efficiency and ultra low hardness leakage
- ➔ Master Controller: Fully programmable electronic controller with adjustable cycles
- ➔ Alternating Flow: One tank is always off-line for regeneration or ready in stand by.
- ➔ Advanced Diagnostic Information: Easily trouble shoot and access system information displayed in real time
- ➔ Back Wash Override: Reduces regeneration water usage by skipping pre set number of back wash cycles
- ➔ Softwater Refill: Adds treated water to the brine tank to keep brine clean and reduces maintenance
- ➔ Optional: Stainless steel piping manifold
- ➔ Optional: Aux output closed during full regeneration cycle



85 TA 1" Series Water Softener

**Continuous
Soft Water
24-7**



Model	Capacity	Resin per Tank	Salt Usage		Flow Rates per Tank				Dimensions	
					Critical	85TA		Max Flow	Mineral Tank	Brine Tank
					Flow	@ 15 PSI	@ 25 PSI	To Drain		
					USGPM	USGPM	USGPM	USGPM	in	in
	@ 15 lbs/Ft3	Ft ³	@ 15 lbs/Ft3	@ 10 lbs/Ft3	l/s	l/s	l/s	l/s	mm	mm
	@ 10 lbs/Ft3	M ³	Lbs (Kg)	Lbs (Kg)	USGPM	USGPM	USGPM	USGPM		
85TA-23	23,000	0.77	11.5 (5.2)	6.75 (3.1)	3.75	10.4	14.3	1.5	8 x 44	18 x 35
	20,000	0.02			0.24	0.66	0.9	0.09	203 x 1118	460 x 876
85TA-30	30,000	1	15 (6.8)	10 (4.5)	5.0	11	15	2	9 x 48	18 x 35
	27,000	0.03			0.32	0.69	0.95	0.13	229 x 1219	460 x 876
85TA-45	45,000	1.5	23 (10.2)	15 (6.8)	7.5	11.2	15.1	2.4	10 x 54	18 x 35
	40,500	0.04			0.47	0.71	0.95	0.15	254 x 1372	460 x 876
85TA-60	60,000	2	30 (13.6)	20 (9.1)	10	12.2	16.2	3.5	12 x 52	20 x 37
	54,000	0.06			0.63	0.77	1.02	0.22	305 x 1321	516 x 950
85TA-90	90,000	3	45 (20.5)	30 (13.6)	15	12.6	16.6	5	14 x 65	23 x 41
	81,000	0.08			0.95	0.79	1.05	0.32	356 x 1651	584 x 1029

Water Softeners

EcoSmart Series Water Softener



ECS-20

#15010410



ECS-24

#15010411



ECS-34/39

#15010412 (ECS-34)
#15010414 (ECS-39)

Features:

- Engineered for ultimate efficiency on clean municipal water applications
- Compact design for small spaces
- Uses over 75% less salt & water than conventional water softeners
- EcoSmart™ Intelligent electronic control:
 - Simple intuitive electronics. No confusing codes or symbols!
 - Rotating performance information display!
 - Adjustable cycles for peak efficiency!
- High-efficiency fine mesh cation resin
- Quality injection & blow molded cabinet
- Push release hinged salt lid for easy salt refill
- Brine safety valve provides additional overflow protection
- ECS-34 model not only softens but also filters out bad tastes & odors caused by chlorine & organics
- Removes up to 10 ppm ferrous iron

Eco-Friendly Efficiency



Quality & Warranty

EcoSmart™ Water Softeners are built to last! All softeners are third party certified to meet the industry's most exacting standards and backed by one of the industries strongest warranties:

- Seven Year System Warranty
- Lifetime Pressure Tank & Cabinet Warranty



7 Year Warranty Control Valve



Lifetime Warranty Pressure tank

Compact Design

Super compact design is perfect for main floor laundry or where space is at a premium!



Easy Installation

Complete installation kit including bypass, plumbing fittings & drain tubing. Quick connect fittings for simple installation. Includes easy to follow installation guide.

Installation Kit (Included)

- 3/4" Male Quick Connects
- 10 ft Drain Line
- Drain Line Clamp

Installation Kit (Optional)

- New Quick Connect Stainless Steel Flexi-Connector Kits
- Two 18" flexible water connectors with 3/4" John Guest® Quick Connect fittings

Specifications	ECS-20	ECS-24	ECS-34	ECS-39
	15010410	15010411	15010412	15010414
Maximum Hardness Removal	19,500 grains	24,180 grains	34,320 grains	39,000 grains
Factory Settings - High Efficiency				
Salt Used	1.5 lbs	2.1 lbs	2.4 lbs	3.0 lbs
Water Used	9.6 gal	11.7 gal	15.8 gal	17.9 gal
System Capacity	7,300 grains	10,200 grains	11,700 grains	15,400 grains
High Capacity Settings				
Salt Used	3.0 lbs	3.7 lbs	5.3 lbs	6.0 lbs
Regeneration Water Used	16.9 gal	21.4 gal	32.5 gal	34.6 gal
System Capacity	12,000 grains	16,800 grains	19,200 grains	25,000 grains
Coconut Activated Carbon	No	No	Yes	No
Integrated Meter in Bypass	Yes	Yes	Yes	Yes
Plumbing Connections	3/4" or 1"	3/4" or 1"	3/4" or 1"	3/4" or 1"
Flow Rate @ 15 psi Pressure Drop	10.9 gpm	10.2 gpm	10.0 gpm	10.0 gpm
Salt Storage Capacity	80 lbs	120 lbs	170 lbs	170 lbs
Shipping Weight	58.5 lb	68.3 lb	84.3 lb	87.5 lb
Regeneration Type	Co-current / Downflow			
Maximum Efficiency	5,600 grains /lb salt			
Electrical Requirements	120V 50/60 Hz			
Maximum Water Temperature	120 degrees Fahrenheit			
Water Pressure	min. 20 - max. 120 psi			
Foot Print	13" w x 18" d (ECS-20 26" h / ECS-24 35" h / ECS-34&39 43" h)			
Plumbing Connections	Includes 3/4" 90° Elbows & 1" Straight NPT			



EcoSmart™ control valve & pressure tanks are NSF Certified

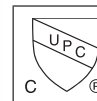

IAPMO R & T Certified against CSA B483.1



IAPMO R & T Certified against NSF/ANSI 44

Shower Softener

Just want soft water for your shower? This compact water-proof shower unit requires no electricity. The one-step manual regeneration is easy to operate. Small portable design makes it perfect for non-winterized cottages.



Features:

- Easy installation
- No electricity required
- Waterproof slide cover
- One step regeneration process



Item #	Model	Mineral Tank Size (IN)	Resin Cu Ft	Brine Tank / Cabinet Size Inches (WxDxH)	Ship Weight (Lbs)
15180001	SHOWER SOFTENER	7 x 13	0.22	8.7 x 14.2 x 19.2	20

New Quick Connect Stainless Steel Flexi-Connector Kits

We are pleased to introduce our new Quick Connect Stainless Steel Flexi-Connector Kits designed specifically for Canature WaterGroup control valves.

The connectors are not only affordable, they provide for faster, easier installations while eliminating two connection points.

Each kit consists of:

- Two 18" long flexible water connectors with John Guest® Quick Connect fittings on one end and proprietary Canature WaterGroup control 3/4" valve bypass connection on the other
- Polybag with merchandising header

Simply push to connect to any 3/4" or 1" copper, CPVC or PEX piping with no tools!



60010618 3/4" J6 x 3/4 Canature WaterGroup Bypass
60010619 1" J6 x 3/4 Canature WaterGroup Bypass

Whole-House Automatic Water Filters

Protect Your Plumbing From Bad Taste and Odor Caused by Chlorine and Other Chemicals.

Remove Disinfectants From Your Water

Once water arrives safely at your home there is no further need for disinfectants. In fact they are undesirable!

- Taste and bad odor
- Dry skin
- Damage plumbing
- Can produce potentially harmful by-products

Leaky Faucet or Toilet?

Chlorine is a strong oxidant that quickly destroys plastic & rubber seals & gaskets in appliances & plumbing causing leaks.

Pin Hole Leaks in Pipes!

Chloramines are corrosive by nature and will eventually cause costly damage to plumbing – causing pitting & pin hole leaks.



WaterGroup 185 Series Water Filters

Problem water is no problem with our full line of WaterGroup 185 Water Filters. Eliminate iron, sediment, bad tastes, stains and odors, as well as, color caused by organics. The high-efficiency control valve monitors water usage and flushes the system automatically, readying it for operation again.

- ➔ **Taste & Odor Filters (ACF):** Chlorine and organic matter can make your water smell and taste terrible. The WaterGroup 185 Taste & Odor filter uses high-quality granular activated carbon to absorb the problem-causing substances.
- ➔ **Chloramine Removal Filters (CLAF):** Chloramines are now commonly used to disinfect municipal water supplies causing taste & odor problems. To remove chloramines a special catalytically enhanced carbon is required.
- ➔ **Multi Media Filters (MM):** Cloudy water means you likely have suspended silt: or sediment. Restore your water to crystal clear as the WaterGroup 185 Multi-Media filter traps particulate matter as small as 20 microns.
- ➔ **Nexsand Turbidity Filters (Ultra MF):** Remove suspended solids, Ferric Hydroxide (Red Water Iron) or Sediment from your well or water system down to 5 Microns. Nexsand has proven extremely effective and will double the service flow of Multi Media or Sand Filters.
- ➔ **Neutralizing Filters (NNF):** The WaterGroup 185 Neutralizing filters raise the pH of acidic water to neutralize corrosiveness protecting fixtures, pipes and appliances.
- ➔ **Iron & Sulfur Filters (ISF):** Water comes in contact with manganese greensand causing oxidization into solids which can be trapped in the filter bed



Chloramine (CLAF) Units use Two Tank System for effective reduction of chloramines



Tank Mate™
Included with all systems

Features:

- ➔ Exclusive NSF Certified control valve with reliable electronic sensors, adjustable cycle time and proven piston, seal & spacer design
- ➔ NSF Certified fibreglass pressure tank
- ➔ Tank jackets reduce condensation.
- ➔ User-friendly backlit LCD display
- ➔ Simple set up and programming with no confusing codes or symbols to remember
- ➔ Automatic Vacation Mode prevents media cementing
- ➔ “No Touch” LCD information display rotates key info like last regeneration date, current flow rate & peak flow rate
- ➔ Unique, compact one piece bypass with integrated turbine meter
- ➔ Time saving quick connect fittings on bypass, drain & brine line. Even the power cord has quick connects
- ➔ Drain line o-ring. No need for Teflon
- ➔ Audible Cycle Advance Alarm
- ➔ 48 hour self charging battery back-up
- ➔ Meter Immediate, Meter Delayed, and Meter with Day Override
- ➔ Includes hose clamp and 10' of drain tubing

185 Filters

Specifications	WG185ACF75	WG185ACF10	WG185ACF15	WG185ACF20	WG185ACF30
	2150	2151	2152	2153	2220
Normal Service Flow Rate	4.0 gpm	5.0 gpm	7.0 gpm	10 gpm	12.0 gpm
Peak Service Flow Rate	5.0 gpm	7.0 gpm	10.0 gpm	12.0 gpm	15.0 gpm
Backwash Flow Rate	3.5 gpm	4.0 gpm	5.0 gpm	7.0 gpm	10.0 gpm
Filter Media Volume - Cubic Feet	0.75 ft ³	1.0 ft	1.5 ft	2.0 ft	3.0 ft
Filter Tank Size	8x44	9x48	10x54	12x52	14x65
Tank Jacket / Media Loaded	Yes	Yes	Yes	No	No
Shipping Weight	50 lbs	60 lbs	78 lbs	95 lbs	138 lbs

Specifications	WG185CLAF75	WG185CLAF10	WG185CLAF15	WG185CLAF20
	2221-1	2222-1	2223-1	2224-1
Recommended Flow Rates	4.0 gpm	5.0 gpm	7.5 gpm	10.0 gpm
Backwash Flow Rate	3.5 gpm	4.0 gpm	5.0 gpm	7.0 gpm
Filter Media Volume - Cubic Feet	1.5 ft ³	2.0 ft	3.0 ft	4.0 ft
Filter Tank Size (qty 2)	8x44	9x48	10x54	12x52
Tank Jacket	Yes	Yes	Yes	No
Shipping Weight	100 lbs	120 lbs	155 lbs	190 lbs
Carbon Type	Canature Catalytic Carbon			

Specifications	WG185MMF75	WG185MMF10	WG185MMF15	WG185MMF20	WG185MMF30
	2166	2167	2168	2169	2225
Normal Service Flow Rate	4.0 gpm	5.0 gpm	7.0 gpm	10.0 gpm	12.0 gpm
Peak Service Flow Rate	5.0 gpm	7.0 gpm	10.0 gpm	12.0 gpm	15.0 gpm
Micron Rating	15-20 micron	15-20 micron	15-20 micron	15-20 micron	15-20 micron
Backwash Flow Rate	4.0 gpm	5.0 gpm	7.0 gpm	10.0 gpm	14.0 gpm
Filter Media Volume - Cubic Feet	0.75 ft ³	1.0 ft	1.5 ft	2.0 ft	3.0 ft
Filter Tank Size	8x44	9x48	10x54	12x52	14x65
Tank Jacket / Media Loaded	Yes	Yes	Yes	No	No
Shipping Weight	79 lbs	118 lbs	144 lbs	198 lbs	342 lbs

Specifications	WG185ULTRAMF75	WG185ULTRAMF10	WG185ULTRAMF15	WG185ULTRAMF20
	2170	2171	2172	2173
Normal Service Flow Rate	4.0 gpm	5.0 gpm	8.0 gpm	10.0 gpm
Peak Service Flow Rate	7.0 gpm	8.0 gpm	10.0 gpm	12 gpm
Micron Rating	3-5 micron	3-5 micron	3-5 micron	3-5 micron
Backwash Flow Rate	5.0 gpm	7.0 gpm	10.0 gpm	14.0 gpm
Filter Media Volume - Cubic Feet	0.75 ft ³	1.0 ft	1.5 ft	2.0 ft
Filter Tank Size	8x44	9x48	10x54	12x52
Tank Jacket	Yes	Yes	Yes	No
Shipping Weight	90 lbs	135 lbs	205 lbs	255 lbs

Specifications	WG185NNF75	WG185NNF10	WG185NNF15	WG185NNF20	WG185NNF30	WG185NNF10CALC	WG185NNF15CALC
	2174	2175	2176	2177	2226	2227	2228
Normal Service Flow Rate	2.0 gpm	3.0 gpm	5.0 gpm	6.0 gpm	7.0 gpm	3.0 gpm	5.0 gpm
Peak Service Flow Rate	3.5 gpm	5.0 gpm	8.0 gpm	10.0 gpm	12.0 gpm	5.0 gpm	8.0 gpm
Backwash Flow Rate	3.5 gpm	4.0 gpm	5.0 gpm	7.0 gpm	10.0 gpm	4.0 gpm	5.0 gpm
Filter Media Volume - Cubic Feet	0.75 ft ³	1.0 ft	1.5 ft	2.0 ft	3.0 ft	1.0 ft	1.5 ft
Filter Tank Size	8x44	9x48	10x54	12x52	14x65	9x48	10x54
Tank Jacket / Media Loaded	Yes	Yes	Yes	No	No	Yes	Yes
Shipping Weight	93 lbs	120 lbs	164 lbs	207 lbs	330 lbs	120 lbs	164 lbs

For low pH applications

Specifications	WG185ISF75	WG185ISF10	WG185ISF15	WG185ISF20	WG185ISF30
	2162	2163	2164	2165	2197
Normal Service Flow Rate	3.0 gpm	3.0 gpm	4.0 gpm	5.0 gpm	6.0 gpm
Peak Service Flow Rate	4.0 gpm	5.0 gpm	8.0 gpm	10.0 gpm	12.0 gpm
Backwash Flow Rate	3.5 gpm	4.0 gpm	5.0 gpm	7.0 gpm	10.0 gpm
Compensated Iron Removal Capacity	4,500 ppm	6,000 ppm	9,500 ppm	12,000 ppm	18,000 ppm
KMnO ₄ per Regen	4 oz	4 oz	4 oz	8 oz	8 oz
Filter Media Volume - Cubic Feet	0.75 ft ³	1.0 ft	1.5 ft	2.0 ft	3.0 ft
Filter Tank Size	8x44	9x48	10x54	12x52	14x65
Tank Jacket / Media Loaded	Yes	Yes	Yes	No	No
Shipping Weight	113 lbs	129 lbs	179 lbs	233 lbs	352 lbs
Maximum Combination of Iron X 1, Manganese X 2, H ₂ S X3	10.0 ppm		Maximum Hydrogen Sulfide		3.0 ppm
Maximum Iron (Ferrous)	7.0 ppm		Maximum Man-ganese	5.0 ppm	
Bacterial Iron	0.0 ppm		Minimum pH		7.0

All Filters	
Plumbing Connections	Includes 3/4" 90° Elbows & 1" Straight NPT
Electrical Requirements	Input 120V 60 Hz - Output 12V 650mA
Water Temperature	Min 39 - Max. 100 degrees Fahrenheit
Water Pressure	Min. 20 - Max. 125 psi

WaterGroup 465 BIF Chemical Free Iron Filter



Features:

- ➔ Natural oxidation removes iron, manganese and hydrogen sulfide without chemicals, air pumps or a venturi
- ➔ Low maintenance two tank system
- ➔ Regenerates less frequently than traditional iron filters using up to 50% less water than manganese greensand filters
- ➔ NSF Certified electronic control valve
- ➔ NSF Certified fibreglass pressure tanks
- ➔ Meter Immediate, Meter Delayed, Meter with Day Override, Vacation and Calendar Clock mode
- ➔ Adjustable cycle times
- ➔ Unique bypass with an integrated space saving turbine meter and sample port on the inlet. One-piece design avoids meter jamming
- ➔ Time saving quick connect fittings on bypass
- ➔ Quick connect drain line o-ring eliminates need for Teflon
- ➔ Power cord even has quick connect for easy valve spin on
- ➔ Hose clamp and 10' of drain tubing included



7 Year Warranty Control Valve



Lifetime Warranty Pressure tank

Item #	Model	Media Cu Ft	Flow Rate USGPM			Mineral Tank Size	Air Contact Tank	Pipe Size Inches	Ship Weight Lbs
			Service	Peak	Backwash				
2198-1	WG465BIF-75	0.75	2.0	5.0	3.5	8 x 44	8 x 44	3/4"	132
2199-1	WG465BIF-100	1.0	3.0	6.0	5.0	10 x 44	8 x 44	3/4"	150
2200-1	WG465BIF-150	1.5	4.0	10.0	5.0	10 x 54	10 x 54	3/4"	188
2205-1	WG465BIFMN-75	0.75	2.0	5.0	3.5	8 x 44	8 x 44	3/4"	132
2206-1	WG465BIFMN-100	1.0	3.0	6.0	5.0	10 x 44	8 x 44	3/4"	150
2207-1	WG465BIFMN-150	1.5	4.0	10.0	5.0	10 x 54	10 x 54	3/4"	188
940662-1	WG465BIF-100 with Multi Media	1.0	3.0	6.0	5.0	10 x 44	8 x 44	3/4"	150
940663-1	WG465BIF-150 with Multi-Media	1.5	4.0	10.0	7.0	10 x 54	10 x 54	3/4"	188
940366-1	WG465BIF-100 with Catalytic Carbon	1.0	3.0	6.0	5.0	10 x 44	8 x 44	3/4"	150
940365-1	WG465BIF-150 with Catalytic Carbon	1.5	4.0	10.0	5.0	10 x 54	10 x 54	3/4"	188

- BIF MN Models for low pH and/or high manganese applications
 - BIF Iron and Hydrogen Sulfide Filter With Multi Media For Use on Tannin Bearing Water
 - BIF Iron & Hydrogen Sulfide Removal With Catalytic Carbon For Higher Than Normal H2S Removal (up to 10ppm)
 Contact Customer Service or Your Sales Representative for Application Guidelines

Maximum Iron	30.0 ppm
Hydrogen Sulfide	5.0 ppm
Manganese	BIF Model 0.0 ppm / BIFMN Models up to 1.0 ppm
Iron Bacteria Removal	No
pH	BIF Models pH 7.0 - 8.5 / BIFMN Models pH 6.5 -6.9

AIO Chem Free Iron Filter

The AIO Chemical Free Iron filter is intended to be an effective and economical way to remove iron from water without the use of messy and dangerous chemicals or expensive pumps or an external venturi. The AIO valve uses a patented construction to create an air bubble at the upper portion of the tank to oxidize any ferrous iron prior to being filtered by the media. It can also be used to remove low concentrations of dissolved hydrogen sulfide and manganese from water.

How does the AIO (Air Induction Oxidization) filter work?

This filter works by adding oxygen to the incoming water by passing it through a bubble of compressed air. The water is then passed through a special filter bed.

The special media not only increases the pH of the water to enhance iron removal but also acts as a physical barrier to trap iron precipitate.

As more water passes through this iron filter, the oxygen in the unit is used up, and the media gets loaded with iron. The regeneration process then begins in order to replenish the supply of oxygen, and to backwash the precipitated iron trapped in the media bed. The iron removal efficiency will be more effective with high pH water.

The filter is fitted with an inlet check valve to prevent any air from flowing backwards out of the filter tank.



Item #	Model	Media Cu Ft	Flow Rate USGPM			Mineral Tank Size	Pipe Size Inches	Ship Weight Lbs
			Service	Peak	Backwash			

AIO (Air Induction Oxidizer) Chemical Free Iron Filter (Single Tank)

2231	FILTER, WG665FAIO75	0.75	2	4	3.5	8 x 44	3/4"	110
2232	FILTER, WG665FAIO10	1.0	3	6	4	9 x 48	3/4"	145
2233	FILTER, WG665FAIO15	1.5	4	10	5	10 x 54	3/4"	250
2235	FILTER, WG665FAIO75M	0.75	2	4	3.5	8 x 44	3/4"	110
2236	FILTER, WG665FAIO10M	1.0	3	6	4	9 x 48	3/4"	145
2237	FILTER, WG665FAIO15M	1.5	4	10	5	10 x 54	3/4"	250

Bed Type	Application Parameters			
	Iron (ppm)	Manganese (ppm)	Hydrogen Sulfide (ppm)	pH Range
AIO Chem Free	0.0 - 30.0	0.0	0.0 - 1.0	7.0 - 8.5
AIOM Chem Free	0.0 - 30.0	0.0 - 1.0	0.0 - 1.0	6.5 - 8.5

Hydrogen Sulfide Reduction AIO Filter

Does Your Water Stink?

Hydrogen sulfide (H₂S) is a nuisance. It adds an objectionable sulfur-like taste and “rotten egg” odor to drinking water. Left untreated, it can also lead to corrosion in drainage pipes and concrete sewers.

Features:

- ➔ Combines aeration with catalytic carbon technology to effectively reduce sulfur from water.
- ➔ No more bad taste or odor.
- ➔ No Chemicals to buy, mix or add
- ➔ No weekly water tests to perform
- ➔ Simple, Fully Automatic regeneration with Air



Item #	Model	Cat Carbon Cu Ft	Flow Rate USGPM			Mineral Tank Size	Pipe Size Inches	Ship Weight Lbs
			Service	Peak	Backwash			
AIO (Air Induction Oxidizer) Filter For Hydrogen Sulfide Reduction (Single Tank)								
2238	FILTER, WG665FAIOC75	0.75	2	4	3.5	8 x 44	3/4"	110
2239	FILTER, WG665FAIOC10	1.0	3	6	4	9 x 48	3/4"	145
2240	FILTER, WG665FAIOC15	1.5	4	10	5	10 x 54	3/4"	250

Bed Type	Application Parameters			
	Iron (ppm)	Manganese (ppm)	Hydrogen Sulfide (ppm)	pH Range
AIOC Catalytic Carbon	0.0 - 10.0	0.0	0.0 - 3.0	7.0 - 8.5

WG NRV (Non-Regenerating Valve) Whole House Carbon Filter

Economical Reduction of Chlorine, Chloramines and other bad taste & Odors.

Features:

- ➔ Economical whole-house carbon filtration solution for reducing chlorine (TO models) , chloramines (TOK models) and other bad tastes and odors
- ➔ Factory installed one-piece bypass with incorporated meter
- ➔ Time saving quick connect fittings (90° 3/4" NPT Elbows and 1" Straight NPT) included for faster, easier installation. Optional quick connect SharkBite® fittings also available.
- ➔ Five year warranty on Distribution Head
- ➔ Ten Year Warranty on NSF Certified tank



Economical non-back-washing distribution head with convenient quick connect fittings



Specifications	NRV TO-100	NRV TO-150	NRV TOK-100	NRV TOK-150
	15054073	15054074	15054075	15054076
Service Flow Rates				
Normal	5.0 gpm	7.0 gpm	5.0 gpm	7.0 gpm
Peak	7.0 gpm	10.0 gpm	7.0 gpm	10.0 gpm
Filter Media Volume - Cubic Feet	1.0 ft	1.5 ft	1.0 ft	1.5 ft
Filter Tank Size	9x48	10x54	9x48	10x54
Media Type	Coconut Carbon	Coconut Carbon	Coconut Carbon	Coconut Carbon
Media Loaded	Yes	Yes	Yes	Yes
KDF Protector	No	No	Yes	Yes
Tank Jacket	No	No	No	No
Shipping Weight	60 lbs	78 lbs	60 lbs	78 lbs
Plumbing Connections	Includes 3/4" 90° Elbows & 1" Straight NPT. Bypass Included.			
Electrical Requirements	None			
Water Temperature	Min 39 - Max. 100 degrees Fahrenheit			
Water Pressure	Max. 125 psi			

Specialty Systems: SIMTAN PLUS Series



SIMTAN PLUS Series



7 Year Warranty
Control Valve



Lifetime Warranty
Pressure tank

Soften & Filter Problems From Your Water

Many ground water supplies often have multiple problems that are not only an issue from an aesthetic standpoint but in terms of cost when pipes become clogged, fixtures stained and laundry discolored.

Combination units provide one solution for multiple problems saving you space and money

WaterGroup 185 Series Specialty Combination Systems

WaterGroup offers a variety of specialty systems to fix a variety of water problems commonly found in combination in one water supply.

SIMTAN PLUS Series

Hardness, Iron, Manganese, Natural Organic Matter (including Tannins) and Ammonium Removal

Rid your water of hardness minerals (calcium and magnesium) and enjoy soft skin, silky hair, spot free dishes and brighter laundry while protecting your plumbing and water using appliances from scale build-up.

Removing iron and manganese will keep fixtures from getting stained as well as removing the taste and smell.

Ammonium, often found as a by-product in water disinfected with chloramines, is undesirable and can cause bad taste and odor.

Do **NOT** use *Pro Res Care* or other media cleaners with these units as it will damage the media

Specifications	SIMTANPLUS-150 2181-P	SIMTANPLUS-200 2182-P	SIMTANPLUS-250 2262-P	SIMTANPLUS-300 2183-P
Salt Used - Per Regeneration	9.0 lbs	12.0 lbs	15.0 lbs	18.0 lbs
Water Used - Regeneration	74.6 gal	98.9 gal	126.6 gal	153.0 gal
Hardness Removal - Grains	17,100	22,800	28,500	34,200
Advanced Exchange Media (ft3)	1.32ft	1.76 ft	2.20 ft3	2.64 ft
Tank Size	10x54	12x52	13x54	14x65
Top Cone	Yes	Yes	Yes	Yes
Tank Jacket / Media Loaded	Yes	No	No	No
Brine Tank (Inches)	20.3 x 37.4	20.3 x 37.4	20.3 x 37.4	23.0 x 40.5
Salt Storage Capacity	350 lbs	350 lbs	350 lbs	420 lbs
Critical Service Flow Rate	4-6 gpm	6-8 gpm	8-10 gpm	10-12 gpm
Back Wash Flow Rate	2.4 gpm	4.0 gpm	5.0 gpm	7.0 gpm
Shipping Weight	141 lbs	158 lbs	198 lbs	244 lbs
pH	5-9			
Other	Free Chlorine < 1 ppm, TDS < 4000 ppm			
Regeneration Type	Down Flow			
Plumbing Connections	Includes 3/4" 90°Elbows & 1" Straight NPT			
Electrical Requirements	Input 120V 60 Hz - Output 12V 650mA			
Water Temperature	Min 39 - Max. 100° F			
Water Pressure	Min. 20 - Max. 125 psi			

The HIMTLC PLUS needs to be used on well water where the well is greater than 140 feet deep.
CALL CUSTOMER SERVICE TO DETERMINE CORRECT MODEL. WATER TEST RESULTS REQUIRED.

Raw Water Quality Requirements and Efficiency of Purification

Parameters	Influent limitations	Max. Efficiency, %
Hardness	45 gpg	97
Iron*	4 ppm	98
Manganese	2 ppm	98
TOC** (including tannins)	3 ppm	98
Ammonium	4 ppm	90

*All installations require 5 micron pre-filter to be installed prior to this unit. We recommend our 10" or 20" Big Value filter housings with a 5 micron cartridge. If ferric iron levels exceed 3ppm, or high volumes of sediment/turbidity is also present, a regenerating nexsand or multi-media filter should be installed prior to this unit.

**TOC (total organic carbon) is used as a measure of natural organic matter content

185 IronGuard SIM Series

Enjoy Iron-Free Soft Water



Combining proven water softener capabilities with the ability to remove clear water iron, the Iron Guard SIM system provides an effective and economical solution to hard and iron contaminated water. In addition, Iron Guard Plus, is specially designed for application in low pH (acidic) water. Hard water contains dissolved calcium and magnesium which build up inside your water heater, plumbing fixtures and appliances. The minerals also react with soap to form a scum which appears as bathtub ring, greys your laundry and leaves your hair dull and your skin itchy. Iron water leaves yellow, orange or brown stains on your laundry, sinks, tubs and toilets.

Iron Guard contains a bed of fine mesh ion exchange resin beads. As water passes through the bed, calcium and magnesium, the hardness minerals, and any clear water iron are removed and held by the resin. The Iron Guard Plus bed contains calcium carbonate in addition to the fine mesh ion exchange resin. This media combines to raise low pH water to prevent corrosion.

Eventually, the resin beads become saturated and must be regenerated. A brine solution is drawn into the bed to drive out the accumulated minerals. This process is called ion exchange. After the minerals and brine are rinsed out with fresh water, the regenerated resin is ready to soften your water again. The demand regeneration control valve includes a metering system which monitors your soft water use, regenerating only when necessary based on your water usage. Consequently, you save salt, water and money.

Specifications	WG185SIM30	WG185SIM45	WG185SIM60	WG185SIM90	WG185SIM30+
	2137	2138	2139	2178	2140
Factory Settings - Iron & Manganese					
Salt Used - Per Regeneration	12.0 lbs	18.0 lbs	24.0 lbs	36.0 lbs	12.0 lbs
Water Used - Regeneration	52.2 gal	74.4 gal	101.4 gal	166 gal	52.2 gal
Hardness Removal - Grains	30,000	45,000	60,000	90,000	30,000
Resin Quantity - Cubic Feet	1.0 ft	1.5 ft	2.0 ft	3.0 ft	1.0 ft
Calcite	No	No	No	No	Yes
Tank Size	9x48	10x54	12x52	14x65	10x54
Tank Jacket / Media Loaded	Yes	Yes	No	No	Yes
Brine Tank / Cabinet Size (Inches)	18.1 x 34.5	20.3 x 37.4	20.3 x 37.4	23.0 x 40.5	18.1 x 34.5
Salt Storage Capacity	240 lbs	350 lbs	350 lbs	420 lbs	240 lbs
Flow Rate @ 15 psi Pressure Drop	11.0 gpm	11.2 gpm	12.2 gpm	12.6 gpm	11.2 gpm
Flow Rate @ 25 psi Pressure Drop	15.0 gpm	15.1 gpm	16.2 gpm	16.6 gpm	15.1 gpm
Back Wash Flow Rate	2.1 gpm	2.4 gpm	3.5 gpm	5.0 gpm	2.4 gpm
Shipping Weight	125 lbs	158 lbs	175 lbs	247 lbs	139 lbs
Regeneration Type	Co-Current / Down Flow				
Maximum Hardness	75 Grains Per Gallon				
Maximum Iron (Ferrous)	10 ppm				
Maximum Manganese	5 ppm				
Resin Type	Purolite® SST-60				



SIM Series includes Pro Easy Feeder Starter Kit.

185 TAN

This system uses Anion exchange resin to remove color caused by organic decay - greatly improving aesthetics and preventing costly staining.



Specifications	WG185TAN10	WG185TAN15	WG185TAN20	WG185TAN30
Purolite 850 Models*	2229	2143	2144	2145
Purolite 860 Models*	2230	2146	2147	2148
Factory Settings - High Capacity				
Salt Used - Per Regeneration	12.0 lbs	18.0 lbs	24.0 lbs	36.0 lbs
Water Used - Regeneration	64.3 gal	90.3 gal	124.6 gal	196.2 gal
Tannins Removal	2000 ppm	3000 ppm	4000 ppm	6000 ppm
Resin Quantity - Cubic Feet	1.0 ft	1.5 ft	2.0 ft	3.0 ft
Tank Size	9x48	10x54	12x52	14x65
Tank Jacket / Media Loaded	Yes	Yes	No	No
Brine Tank / Cabinet Size (Inches)	18.1 x 34.5	20.3 x 37.4	20.3 x 37.4	23.0 x 40.5
Salt Storage Capacity	240 lbs	350 lbs	350 lbs	420 lbs
Recommended Service Flow Rate	3.0 gpm	4.5 gpm	6.0 gpm	9.0 gpm
Flow Rate @ 15 psi Pressure Drop	11.0 gpm	11.2 gpm	12.2 gpm	12.6 gpm
Flow Rate @ 25 psi Pressure Drop	15.0 gpm	15.1 gpm	16.2 gpm	16.6 gpm
Back Wash Flow Rate	2.0 gpm	2.4 gpm	3.5 gpm	5.0 gpm
Shipping Weight	122 lbs	155 lbs	158 lbs	244 lbs
Regeneration Type	Co-Current / Down Flow			
Maximum Tannins	3.0 ppm (Contact Customer Service for higher levels)			
Plumbing Connections	Includes 3/4" 90°Elbows & 1" Straight NPT			
Resin Type	Canature Anion Resin			
Electrical Requirements	Input 120V 60 Hz - Output 12V 550mA			
Water Pressure	Min. 20 - Max. 125 psi			

185 HTO



Rid your water of hardness & bad tastes and odor caused by chlorine, chloramines or organic matter.

The unique two tank system keeps the two media beds separate and allows for more carbon contact improving chlorine, chloramines and organic removal.

Because the carbon may need to be replaced before the softening resin, the two tank system allows for replacement without having to change the resin bed unlike many traditional mixed bed systems. Same benefit as separate systems but with cost of only one control valve.

Features:

- ➔ Dedicated softening & carbon filtration tanks provide truly refined water
- ➔ NSF Certified control valve with electronic sensors, adjustable cycles & proven piston, seal & spacer design
- ➔ Reverse Flow regeneration preserves unused portion of softening bed from unnecessary exchange saving salt
- ➔ Precision brining calculates the exact amount of brine required to regenerate saving up to 30% more salt
- ➔ Backwash Frequency Preset for clean municipal water saves water by matching backwash to water quality need
- ➔ Soft Water brine tank refill keeps tank & injectors clean
- ➔ Automatic system refresh flushes stagnant water
- ➔ NSF Certified fiberglass pressure tank
- ➔ WQA Gold Seal Certified cation resin
- ➔ User-friendly backlit LCD display
- ➔ "No Touch" rotating information display

Specifications	WG185HTO25	WG185HTO38	WG185HTO50	WG185HTO75
	2188-1	2189-1	2190-1	2191-1
Factory Settings				
Salt Used - Per Regeneration	6.0 lbs	9.0 lbs	12.0 lbs	18.0 lbs
Water Used - Regeneration	86.4 gal	148 gal	162.4 gal	224.8 gal
Hardness Removal - Grains	25,000	37,500	50,000	75,000
Tank #1 Carbon Quantity - Cubic Feet	1.0 ft	1.50 ft	2.0 ft	3.0 ft
Tank #2 Resin Quantity - Cubic Feet	1.0 ft	1.50 ft	2.0 ft	3.0 ft
Tank Size	9x48	10x54	12x52	14x65
Tank Jacket / Media Loaded	Yes	Yes	No	No
Brine Tank / Cabinet Size (Inches)	18.1 x 34.5	18.1 x 34.5	20.3 x 37.4	23.0 x 40.5
Salt Storage Capacity	240 lbs	240 lbs	350 lbs	420 lbs
Flow Rate @ 15 psi Pressure Drop	7.2 gpm	7.4 gpm	9.0 gpm	9.2 gpm
Flow Rate @ 25 psi Pressure Drop	10.0 gpm	10.1 gpm	11.9 gpm	12.1 gpm
Back Wash Flow Rate	2.4 gpm	3.5 gpm	4.0 gpm	5.0 gpm
Shipping Weight	154 lbs	171 lbs	214 lbs	232 lbs
Regeneration Type	Counter Current / Up Flow			
Plumbing Connections	Includes 3/4" 90°Elbows & 1" Straight NPT			
Resin Type	Canature 8% High Capacity Ion Exchange Resin			
Carbon Type	Catalytic Carbon			
Electrical Requirements	Input 120V 60 Hz - Output 12V 650mA			
Water Temperature	Min 39 - Max. 100 degrees Fahrenheit			
Water Pressure	Min. 20 - Max. 125 psi			

185 HEDP



On very hard water supplies (> 75 gpg), a common problem with single tank water softeners is the occurrence of hardness leakage or 'slippage' as the extreme hardness will find a channel through the resin bed.

The WaterGroup High-Efficiency Dual Pass (HEDP) Water Softener uses a two tank system to prevent this problem. The first tank acts as the workhorse by significantly reducing the water hardness. The second tank acts as a 'polisher' and prevents slippage as the overpowering high hardness condition has been significantly reduced. This also increases the contact time with the softening resin meaning more consistent, softer water.

Salt efficiency is even more important on high hardness situations. The WaterGroup HEDP offers salt-efficient reverse flow regeneration with precision brining for ultimate salt savings.

- ➔ Two tank system provides softer, more consistent water quality and prevents hardness slippage which can occur in single tank systems
- ➔ Perfect for high hardness (typically > 75 gpg) residential and light commercial applications such as boiler feed systems
- ➔ More cost effective than larger single tank systems
- ➔ Reverse Flow Regeneration preserves unused portion of softening bed from unnecessary exchange saving salt



Specifications	WG185HEDP-100	WG185HEDP-150	WG185HEDP-200	WG185HEDP-250
	2192-1	2193-1	2194-1	2195-1
Factory Settings				
Salt Used - Per Regeneration	12.0 lbs	18.0 lbs	24.0 lbs	30.0 lbs
Water Used - Regeneration	86.4 gal	148 gal	162.4 gal	224.8 gal
Hardness Removal - Grains	30,000	45,000	60,000	75,000
Tank #1 Resin Quantity - Cubic Feet	1.0 ft	1.50 ft	2.0 ft	2.5 ft
Tank #2 Resin Quantity - Cubic Feet	1.0 ft	1.50 ft	2.0 ft	2.5 ft
Tank Size	9x48	10x54	12x52	13x54
Tank Jacket / Media Loaded	Yes	Yes	No	No
Brine Tank / Cabinet Size (Inches)	23.0 x 40.5	23.0 x 40.5	23.0 x 40.5	29.1 x 50.2
Salt Storage Capacity	350 lbs	420 lbs	420 lbs	420 lbs
Flow Rate @ 15 psi Pressure Drop	7.2 gpm	7.4 gpm	9.0 gpm	9.2 gpm
Flow Rate @ 25 psi Pressure Drop	10.0 gpm	10.1 gpm	11.9 gpm	12.1 gpm
Back Wash Flow Rate	2.0 gpm	2.4 gpm	3.5 gpm	4.0 gpm
Shipping Weight	184 lbs	201 lbs	244 lbs	262 lbs
Regeneration Type	Counter Current / Up Flow			
Plumbing Connections	Includes 3/4" 90° Elbows & 1" Straight NPT			
Resin Type	Canature 8% High Capacity Ion Exchange Resin			
Electrical Requirements	Input 120V 60 Hz - Output 12V 650mA			
Water Temperature	Min 39 - Max. 100 degrees Fahrenheit			
Water Pressure	Min. 20 - Max. 125 psi			

185 NeutraSoft Two Tank Water Conditioning System

Neutralize Corrosiveness & Remove Hardness to Protect Fixtures, Pipes & Appliances

Acidic waters on contact slowly dissolve the Calcite media contained in the first tank to raise the pH which reduces the potential leaching of copper, lead and other metals typically found in plumbing systems.

As the Calcite neutralizes the water, it will increase the hardness of the water. The second tank contains cation exchange resin to remove the hardness leaving you with pH balanced, luxuriously soft water.

Features:

- Economical two tank system is operated using one control valve. Simplifies installation and lowers cost.
- Dome hole neutralizing tank allows for easy replenishment of consumable calcite media
- Exclusive WG 185UF Series control valve with reliable electronic sensors, piston, seals and spacer technology
- High-efficiency upflow regeneration for ultimate salt savings and softer water
- Time saving quick connect fittings for faster, easier installation
- Factory installed one-piece bypass with incorporated meter
- Fully adjustable cycle times
- Meter Immediate, Meter Delayed, Meter with Day Override
- Integrated turbine meter
- 48 hour self charging battery back-up keeps time-of-day stored while program settings are kept in permanent memory
- Large user friendly color display shows time of day, total remaining capacity, and flow indication
- Simple electronics and programming.
- Lifetime Warranty on NSF Certified tank
- Seven year warranty on NSF Certified control valve



Specifications	WG185HNU45
	2196-1
Service Flow Rates	
Normal	5.0 gpm
Peak	8.0 gpm
Backwash Flow Rate	5.0 gpm
Filter Media Volume - Cubic Feet	1.5 ft
Resin Quantity - Cubic Feet	1.5 ft
Tank Size	10x54
Tank Jacket / Media Loaded	No
Brine Tank / Cabinet Size (Inches)	18.1 x 34.5
Salt Storage Capacity	240 lbs
Shipping Weight	311 lbs
Regeneration Type	Counter Current / Up Flow
Plumbing Connections	Includes 3/4" 90°Elbows & 1" Straight NPT
Resin Type	Canature 8% High Capacity Ion Exchange Resin
pH Adjustment Media	Canature Calcite
Electrical Requirements	Input 120V 60 Hz - Output 12V 650mA
Water Temperature	Min 39 - Max. 100 degrees Fahrenheit
Water Pressure	Min. 20 - Max. 125 psi



Dome hole port on tank allows for easy replenishment of Calcite neutralizing media

AQUA FLO[®]
PLATINUM

AQUA FLO[®]

Reverse Osmosis
Ultra Filtration
Under Sink Filtration
Designer Faucets
& Accessories



Aqua Flo Platinum QCRO & QCUF Drinking Water Systems

AQUA FLO[®]
PLATINUM

Customized Drinking Water

Water conditions can vary even in the same community. The Aqua Flo Platinum QCRO System can be configured to meet your specific requirements. There are ten interchangeable filters with a variety of treatment options that can be tailored to local water conditions, so your water is the best it can be.

If you're concerned about RO reject water or RO drain line makes installation difficult, we offer UltraFiltration (UF).* The UF does not have a drain line to run, your cost is lesser than RO and there is no waste.

The innovative QC twist and lock design makes service simple. Twist off the old cartridge and twist on the new. No messy sump removal. Aqua Flo Platinum HP systems make drinking water better and life easier.

* Check with water treatment specialist to recommend you an RO or UF system depending on your untreated water quality.



QCRO



QCUF

“The innovative QC twist and lock design makes service simple.”



Aqua Flo Platinum QCRO & QCUF Drinking Water Systems

Product Specifications

Sediment Filters. Screens out sediments and particles. Various micron size filters are available.

Carbon Filters. Reduces elements that cause water to taste and smell unpleasant, including chlorine taste and odor.

Reverse Osmosis Filters. Reduces dissolved substances. Various capacity membranes are available.

Specialty Filters. Optimize drinking water taste and adjust to local water supply with a wide array of custom filter options.



Manifold Assembly. The single manifold ensures reliability. Houses four separate filter technologies in a unique space saving design.

Automatic Shutoff Valve. Shuts off the system when reservoir tank is full.

Reservoir Tank. Durable, high quality, powder coated, steel tank ensures you'll have a plentiful supply of refreshing water. Various size tanks are available.

Designer Faucet. Multiple styles and colors are available. (Standard faucet shown)

Filter Cartridge and Single Stage Standalone System Specifications

	Sediment Filter	Carbon Block Filter	Carbon Block Filter	GAC Carbon Filter	pH Booster Filter Cartridge	UF (Hollow Fiber) Membrane	Carbon Block - 1 Mic Filter
Purpose	Sediment Removal	Chlorine Taste and Odor	Chlorine Taste and Odor	Polishing - Taste and Odor	Raise pH of water and removal of chlorine, taste and odor	Ultra Fine Filtration	Chlorine Taste and Odor, Particulate Reduction
Type	Polypropylene	Carbon Block	Carbon Block	Granular Activated Carbon Filter	pH Booster and Remineralizer	Hollow Fiber Mechanical Filtration	Carbon Block
Micron	5	5	50	-	-	0.1	1
Capacity*	2000 gallons	2000 gallons	2000 gallons	2000 gallons	To be changed every 6 months	To be changed every 12 months	750 Gallons
Minimum Flow Rate @ 60psi	0.5 gal/min	0.5 gal/min	0.5 gal/min	0.5 gal/min	0.5 gal/min	0.5 gal/min	0.5 gal/min
Single Stage System Model #**	SEDQC1/4	CBQC1/4	CB50QC1/4	GACQC1/4	PHQC1/4	UFQC1/4	CB1QC1/4

* May vary depending on water quality

** Single Stage Standalone System Port Connection Size - 1/4" Quick Connect

Standard System Specifications*

Model	QCRO4V-50	QCRO4V-75	QCUF
Number of Stages	4	4	4
Stage 1 (Pre-Filter)	Sediment Filter	Sediment Filter	Sediment Filter
Stage 2 (Pre-Filter)	Activated Carbon Filter	Activated Carbon Filter	Sediment Filter
Stage 3 (Membrane)	Thin Film Composite Membrane	Thin Film Composite Membrane	Thin Film Composite Membrane
Stage 4 (Post-Filter)	Activated Carbon Filter	Activated Carbon Filter	Activated Carbon Filter
Output (GPD)†	50	75	720



Feed Water Guidelines	
Maximum TDS	2000 ppm
Hardness	<7gpg
Iron (Fe)	<0.2ppm
Manganese (Mn)	<0.05ppm
Hydrogen Sulfide	0.0ppm
Turbidity	<1.0NTU
Feed Water Pressure	40-100psi
Booster Pump Models	15 - 60 psi
Temperature	40-100°F
pH Range	3.0-11.0
Note: Pretreatment suggested if conditions exceed parameters. Must be installed on potable water.	

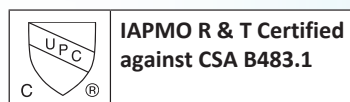
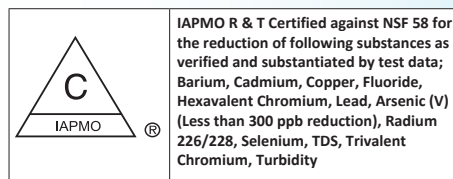

Aqua Flo Platinum QCRO & QCUF Drinking Water Systems

PART #	DESCRIPTION	WEIGHT (LBS)
AQUA FLO PLATINUM QCRO (Quick Change) Reverse Osmosis c/w 4.0 Gal Metal Storage Tank		
1340302-60	AQF PLAT QCRO4V-50, 50GPD, STD CHROME AG FAUCET	20
1340302-60-A	AQF PLAT QCRO4V-50, 50GPD, 50 MICRON CARBON, STD CHROME AG FAUCET	20
1340302-60-D	AQF PLAT QCRO4V-50, 50GPD, DELUXE CHROME AG VS888 FAUCET	20
1340303-60	AQF PLAT QCRO4V-75, 75GPD, STD CHROME AG FAUCET	20
1340303-60-A	AQF PLAT QCRO4V-75, 75GPD, 50 MICRON CARBON, STD CHROME AG FAUCET	20
1340303-60-D	AQF PLAT QCRO4V-75, 75GPD, DELUXE CHROME AG VS888 FAUCET	20
QCUF (QUICK CHANGE) ULTRAFILTRATION		
1340201-60	QCUF 4 STAGE, ULTRAFILTRATION, STD FAUCET	14
1340201-60-D	QCUF 4 STAGE, ULTRAFILTRATION, DELUXE CHROME AG VS888 FAUCET	14
1340201-60-A	QCUF 4 STAGE, ULTRAFILTRATION, STD FAUCET, 50 MICRON CARBON	14
1340201-60-A-D	QCUF 4 STAGE, ULTRAFILT,DELUXE CHROME AG VS888 FAUCET, 50μ CARBON	14
1340201-60-A-D-S	QCUF 4 STAGE, ULTRAFILT,DELUXE BRIGHT NICKEL AG VS888 FAUCET, 50μ CARBON	14
QC SINGLE FILTRATION SYSTEMS (C/W MOUNTING BRACKET)		
41407001-14	SEDQC1/4 SEDIMENT FILTER	1.5
41407002-14	CBQC1/4 CARBON BLOCK FILTER	1.5
41407006-14	CB50QC1/4 CARBON BLOCK FILTER - 50 MICRON	1.5
41407004-14	GACQC1/4 GAC CARBON FILTER	1.5
41407007-14	PHQC1/4 pH BOOSTER FILTER	1.5
41407005-14	UFQC1/4 ULTRA FILTRATION (HOLLOW FIBRE) MEMBRANE	1.5
41407009-14	CB1QC1/4 CARBON BLOCK FILTER - 1 MICRON	1.5
QUICK CHANGE REPLACEMENT FILTERS		
41407011	REPLACEMENT FILTER KIT FOR QCRO (1 SEDIMENT 41407001 / 2 CARBON BLOCK 41407002)	3
41407001	SEDIMENT FILTER	1
41407002	CARBON BLOCK FILTER	1
41407006	CARBON BLOCK FILTER -50 MICRON	1
41407004	GAC CARBON FILTER	1
41407007	pH BOOSTER FILTER	1
41407005	UF (HOLLOW FIBER) MEMBRANE	1
41407009	CARBON BLOCK - 1 MICRON	1
41407003	RO MEMBRANE 50 GPD	1
41407008	RO MEMBRANE 75 GPD	1

Aqua Flo Platinum 1240 Series

Aqua Flo Platinum 1240's advanced reverse osmosis drinking water systems are a natural and economical solution for providing your family with high quality drinking water. With a space-saving ultra slim profile, the system tucks neatly under your kitchen sink providing bottled water quality right from your very own tap.

All systems are backed by a two year limited warranty. The Smartap® water quality monitor found on the Push Button designated models is backed by a five year limited warranty.

All models feature:

- ➔ At a touch of the button, the Push Button Monitor option alerts you when it is time to change your filters.
- ➔ High quality reverse osmosis membrane
- ➔ Choice of 25, 50 and 75 gallons per day membranes
- ➔ Sediment pre-filtration
- ➔ Pre & Post Carbon block filtration
- ➔ 3/8" tubing from RO to tank and faucet for higher flow
- ➔ Chrome faucet
- ➔ Simple snap fit cover for ease of service
- ➔ New slim profile with integrated mounting bracket for easy, space saving installation
- ➔ Quick connect fittings
- ➔ Color coded tubing for ease of installation
- ➔ Metal 3.0 gal Storage Tank

“A natural and economical solution for providing your family with high quality drinking water..”



Patented Smartap® model provides a push button monitor alerting you when it is time to replace your RO membrane

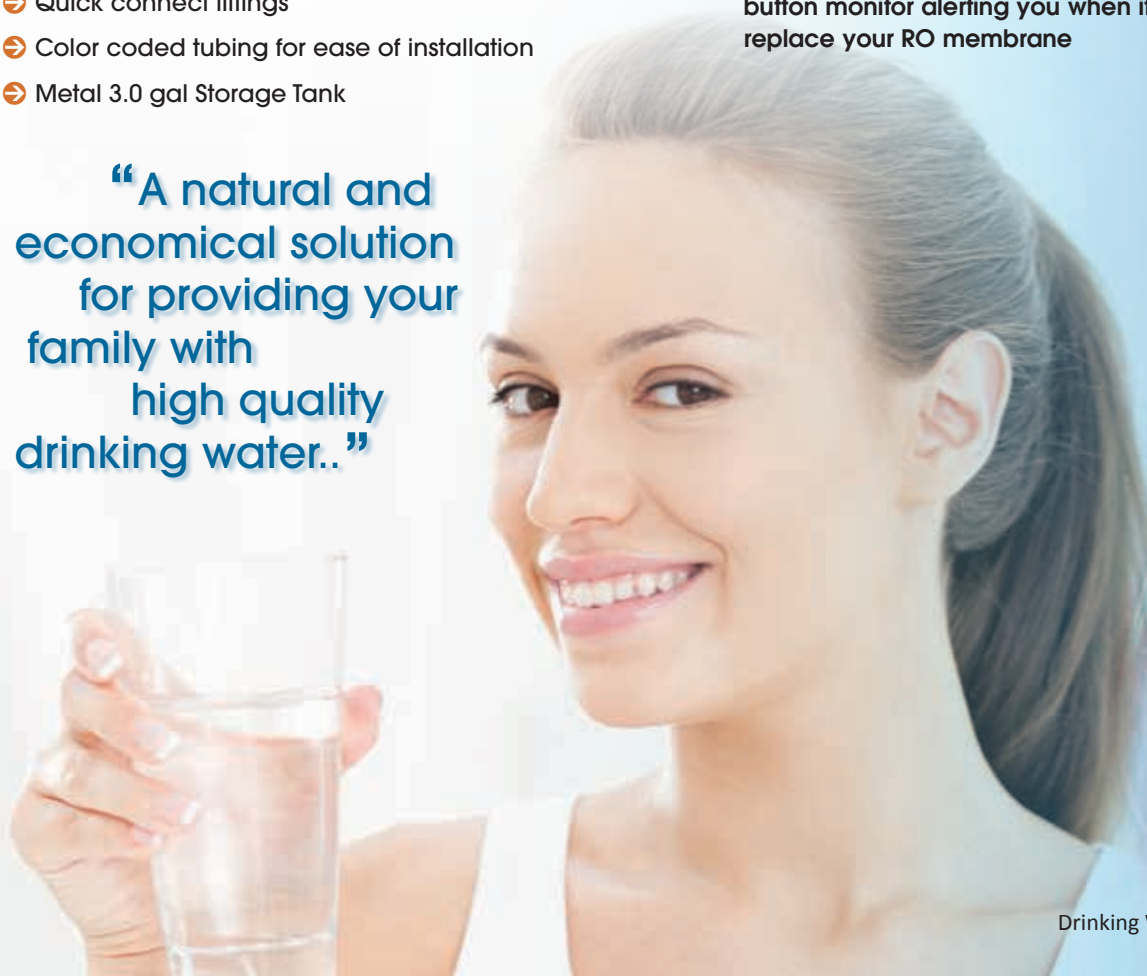

Aqua Flo Platinum 1240 Series



4VTFC-PB Push Button



4VTFC



3VTFC



NOTE: All units ship with Metal storage tank.



Booster Pump (R/O feed water line booster pump)

Raises the water pressure and maintains it at the ideal level for the system to operate at maximum efficiency. Recommended for use on supplies with low pressure or high concentrations of total dissolved solids (TDS). The pump is self-priming and whisper-quiet. It runs on a 24VAC transformer (included) from a standard 120VAC electrical outlet.

System includes: Flexible mounting plate, quick connect fittings and a pressure shut-off switch.

Item #: **92325**

Model: **RO Booster with Pressure Switch and Transformer for 25 to 75 Gallon per day Systems**

Model Description	Vessels	Sediment Filter	Pre-Filter	Membrane	Post-Filter	Rating GPD	Monitor	Dimensions H x W x D (in)
3VTFC50G	3	None	Dual-Purpose	TFC	Activated Carbon	50	None	11 x 15 x 3.75
4VTFC50G	4	String Wound Polypropylene	Activated Carbon	TFC	Activated Carbon	50	None	14 x 15 x 3.75
4VTFC75G	4	String Wound Polypropylene	Activated Carbon	TFC	Activated Carbon	75	None	14 x 15 x 3.75
4VTFC25G-PB	4	String Wound Polypropylene	Activated Carbon	TFC	Activated Carbon	25	Push Button	14 x 15 x 3.75
4VTFC75G-PB	4	String Wound Polypropylene	Activated Carbon	TFC	Activated Carbon	75	Push Button	14 x 15 x 3.75

Feed Water Guidelines	
Maximum TDS	2000 ppm
Hardness	<7ppg
Iron (Fe)	<0.2ppm
Manganese (Mn)	<0.05ppm
Hydrogen Sulfide	0.0ppm
Turbidity	<1.0NTU
Feed Water Pressure	40-100psi
Booster Pump Models	15 – 60 psi
Temperature	40-100°F
pH Range	3.0-11.0
Note: Pretreatment suggested if conditions exceed parameters. Must be installed on potable water.	

PART #	DESCRIPTION
AQUA FLO PLATINUM 1240 SERIES REVERSE OSMOSIS c/w 4.0 Gal Metal Storage Tank	
1240101-00	AQF PLAT 1240 3VTFC25G c/w Non-Air Gap Faucet, Metal Tank
1240102-00	AQF PLAT 1240 3VTFC50G c/w Non-Air Gap Faucet, Metal Tank
1240201-00	AQF PLAT 1240 4VTFC25G c/w Air-Gap Faucet, Metal Tank
1240202-00	AQF PLAT 1240 4VTFC50G c/w Air-Gap Faucet, Metal Tank
1240203-00	AQF PLAT 1240 4VTFC75G c/w Air-Gap Faucet, Metal Tank
1240301-00	AQF PLAT 1240 4VTFC25G c/w Air-Gap Faucet, Metal Tank & Push Button Monitor
1240302-00	AQF PLAT 1240 4VTFC50G c/w Air-Gap Faucet, Metal Tank & Push Button Monitor
1240303-00	AQF PLAT 1240 4VTFC75G c/w Air-Gap Faucet, Metal Tank & Push Button Monitor
1240 SERIES REPLACEMENT CARTRIDGES	
41407013	REPLACEMENT FILTER KIT FOR 1240 RO (1 SEDIMENT 41400008 / 2 CARBON BLOCK 41400009 / Wrench 21401240)
41400076	SEDIMENT/CARBON 'DUAL PURPOSE' FILTER FOR 3 VESSEL MODELS ONLY, BLUE CAP
41400008	STRING WOUND SEDIMENT FILTER FOR 4 VESSEL MODELS ONLY, BLACK CAP
41400009	PRE-CARBON FOR 4 VESSEL & POST CARBON FOR 3 & 4 VESSEL MODELS, BLUE CAP
555718-08	CARBON, AES, 50 MICRON, GREEN CAPS
41400010	LEAD REMOVAL 1 MICRON CARBON BLOCK (BLACK CAPS)
41400011	5S COCONUT CARBON BLOCK (WHITE CAPS)
1240 SERIES REPLACEMENT MEMBRANES	
33001068	25 GPD TFC MEMBRANE, YELLOW CASE, BLACK TAPE, FOR 1230/1240 SERIES
33001033	50 GPD TFC MEMBRANE, YELLOW CASE, WHITE TAPE, FOR 1230/1240 SERIES
33001056	75 GPD TFC MEMBRANE, YELLOW CASE, BLUE TAPE, FOR 1230/1240 SERIES
41400001	9 GPD CTA MEMBRANE (BLUE/YELLOW BAND)
41400002	15 GPD CTA MEMBRANE (BLUE/YELLOW BAND)
33001071	9 GPD TFC MEMBRANE (YELLOW/RED BAND), FOR RO MODELS - 1230, 1240
41400004	15 GPD TFC MEMBRANE (YELLOW/YELLOW BAND), FOR RO MODELS - 1230, 1240

Aqua Flo Reverse Osmosis Systems



Fast, Simple & Sanitary Maintenance!

Quick connect disposable cartridges and membrane make for easy 'Do-It-Yourself' maintenance. With built in auto water shut-offs there is no need to turn off the water supply prior to maintenance.

Because traditional systems require the disinfection of the permanent housing canisters and involve more direct human contact, maintenance can take as much as an hour and if not done properly can result in a contaminated system.

Disposable cartridges change in seconds and reduce contamination risk!

Features:

- ➔ Four stage filtration: 5 micron sediment pre-filter, 10 micron coconut carbon pre & post filters, quick connect 75 GPD NSF Certified TFC membrane
- ➔ Bayonet-style 1/4 turn quick connect disposable cartridges with auto water shut-off
- ➔ Includes non air-gap faucet and 3.0 gallon NSF Certified storage tank. (Air Gap & Designer Faucets Available)
- ➔ 3/8" tubing for high product flow rate from tank to faucet
- ➔ Quick connect fittings, inlet saddle and drain saddle, labelled tubing for easy installation
- ➔ Booster pump model with inlet solenoid raises water pressure to ideal level for maximum efficiency. Recommended on rural supplies with low pressure or high TDS
- ➔ Optional 10 micron carbon block and granular activated carbon filters available.
- ➔ Two year warranty (excluding consumable filter cartridges and RO membrane)
- ➔ Dimensions:
13"w x 14 1/2"h x 4 1/2" d No Pump
14 1/4"w x 16 1/2"h x 6 1/4"d Pump Model

Model Description	Stages	Sediment Filter	Pre-Filter	Membrane	Post-Filter	Rating GPD	Dimensions H x W x D (in)
Aqua Flo 475 PRO	4	5 Micron	10 Micron Coconut Carbon	TFC	10 Micron Coconut Carbon	75	14.5 x 13 x 4.5
Aqua Flo 475 PRO BP	4	5 Micron	10 Micron Coconut Carbon	TFC	10 Micron Coconut Carbon	75	16.5 x 14.5 x 6.25

Feed Water Guidelines	
Maximum TDS	2000 ppm
Hardness	<7gpg
Iron (Fe)	<0.2ppm
Manganese (Mn)	<0.05ppm
Hydrogen Sulfide	0.0ppm
Turbidity	<1.0NTU
Feed Water Pressure	40-100psi
Booster Pump Models	15 - 60 psi
Temperature	40-100°F
pH Range	3.0-11.0

Note: Pretreatment suggested if conditions exceed parameters. Must be installed on potable water.

IN CANADA

PART #	DESCRIPTION
AQUA FLO 475 PRO SERIES REVERSE OSMOSIS	
20010023	AQF 475 PRO SERIES RO c/w NON-AIR GAP FAUCET
20010024	AQF 475 PRO SERIES RO w/ BOOSTER PUMP c/w NON-AIR GAP FAUCET
20010025	AQF 475 PRO SERIES RO c/w AIR GAP FAUCET
20010026	AQF 475 PRO SERIES RO w/ BOOSTER PUMP c/w AIR GAP FAUCET

IN U.S.A.

PART #	DESCRIPTION
AQUA FLO 475 PRO SERIES REVERSE OSMOSIS	
20010024	AQF PREMIUM 475 PRO RO, 75 GPD, NSF 3.2 Storage Tank
20010025	AQF PREMIUM 475 PRO RO w/Booster Pump,75GPD, NSF 3.2 Storage Tank
20010021	AQF 475 PRO RO, 75 GPD, NSF 3.2 Storage Tank
20010022	AQF 475 PRO RO w/Booster Pump,75GPD, NSF 3.2 Storage Tank

NOTE: PREMIUM includes VS905 Satin Nickel Designer Faucet & Shut-off Kit, JG Undersink angle stop, lead free 3/8". NON-PREMIUM includes a standard chrome faucet and saddle valve



Aqua Flo Under Sink Filtration Systems

475QC Filters

The 475 Quick Change Filter Series offers 3, 2 & Single Stage options to provide solutions for a variety of water problems including sediment, rust, bad taste & odor.

Features & Benefits:

- Low cost alternative to RO
- No reject water (100% water used)
- Leaves nutrients in water
- Ultra Filtration on system removes lead, VOC (pesticides, herbicides, chemicals), THM, chlorine, taste and odor and sediment down to 0.2 microns.
- Installation is quick and easy
- Quick change bayonet-style disposable cartridges are more sterile and can be changed in seconds
- Includes standard chrome faucet, inlet saddle valve, and 5ft ¼" tubing
- No storage tank required
- Dimensions:
 - 3 stage - 11.8" w x 14.3" h x 4.5" d
 - 2 stage - 6.3" w x 13.4" h x 3.9" d
 - 1 stage - 2.8" w x 12.4" h x 3.2" d



**Change filters in seconds
without turning off water!
No tools required!**

475 QC Series Filter Systems

PART #	DESCRIPTION	Filter 1	Filter 2	Filter 3
20010201	475QC-3 TRIPLE STAGE ULTRA FILTER	SED	UF	COC
20010202	475QC-2 DOUBLE STAGE DUAL FILTER	SED	COC	
20010203	475QC-1C SINGLE STAGE COCONUT CARBON FILTER	COC		
20010204	475QC-1S SINGLE STAGE SEDIMENT FILTER	SED		
20010205	475QC-1G SINGLE STAGE GAC FILTER	GAC		

475 QC Series Replacement Filters

PART #	DESCRIPTION	MICRON	FLOW RATE	CAPACITY (GALLONS)
65010086	SEDIMENT FILTER SED-10 BLUE (475 Q SERIES)	5	1 GPM	900
65010088	CARBON FILTER COC-10 PURPLE (475 Q SERIES)	10	1 GPM	1,500
65010089	CARBON FILTER GAC-10 YELLOW (475 Q SERIES)	-	0.7 GPM	1,500
65010093	ULTRA FILTER UF-10 BLACK (475 Q SERIES)	0.2	0.7 GPM	1,500

Aqua Flo Economy Reverse Osmosis System

With the quality of our drinking water increasingly coming under question, people are now looking for alternative sources of quality water. Reverse Osmosis Drinking Water Systems provide the most convenient and economical solution. Neatly stored under the counter, the Reverse Osmosis Drinking Water System provides you with clean and delicious water right from its own dedicated tap.

Features:

- ➔ The sediment filter screens out particulate material, such as dirt, sand, or rust, which may clog the other filters in the system.
- ➔ The activated carbon prefilter reduces chlorine which may damage the RO membrane filter.
- ➔ NSF Certified TFC 75 GPD reverse osmosis membrane provides up to 99% Total Dissolved Solids (TDS) rejection
- ➔ The polishing filter adsorbs any residual tastes and odors just before the water is delivered through the faucet.
- ➔ 3.2 Gallon NSF Certified plastic storage tank
- ➔ 3/8" outlet tubing for higher flows
- ➔ Automatic shut-off valve
- ➔ Exclusive serviceable check valve eliminates spring 'chatter' noise common in other RO's
- ➔ Quick connect fittings for ease of installation
- ➔ Plastic bracket
- ➔ Two separate wrenches for use on membrane cap and sump

Booster Pump Model also includes:

- ➔ Pump mounted on RO to maintain constant water pressure to membrane
- ➔ Raises water pressure to ideal level for maximum efficiency
- ➔ Use on rural supplies with low pressure or high TDS
- ➔ Exclusive Auto Flush feature extends membrane life
- ➔ Self-priming and whisper quiet
- ➔ 24VAC transformer (included) from a standard 120VAC electrical outlet
- ➔ Flexible mounting plate, quick connect fittings and pressure shut-off switch



Booster Pump Model: RO75BP



NSF/ANSI Standard 58 Certified Reverse Osmosis Drinking Water Treatment Systems

PART #	DESCRIPTION	Stage 1	Stage 2 and 3	Stage 4	Stage 5	Storage Tank	Faucet
20010073	RO75	Sediment Filter	Activated Carbon Block Filter	Reverse Osmosis Membrane	Activated Carbon Polishing Filter	Plastic Tank - 3.2 Gallons Plastic Tank - 3.2 Gallons	Standard Non-AirGap
20010074							20010076 & 20010077 Models c/w Air Gap Faucets
20010076 & 20010077							

PART #	DESCRIPTION
ECONOMY SERIES REPLACEMENT CARTRIDGES	
60010689	ECONOMY 5 STAGE RO REPLACEMENT KIT (Includes: 26196 (2), 26222, 92020, 60010691)
26196	CB-10-10 CARBON BLOCK, 2.5" X 10", Micron: 10
26222	SPB-5-10 SEDIMENT PRE FILTER, PP, SPUN POLY BONDED, 2.5" X 10", Micron: 5
92020	CARTRIDGE, IN-LINE GAC CARBON, 2" x 10", 1/4" QC, Micron: 5
60010691	WRENCH, RO 75, 5 STAGE
92022	AQFP-1812-75-NPI, 75 GPD TFC MEMBRANE NSF CERTIFIED

Feed Water Guidelines	
Pressure	40 - 100 psi
Temperature	40 - 77 °F
Total Dissolved Solids (TDS) ¹	0 - 2500 ppm (0 - 2500 mg/L)
pH	5 - 10
Chlorine ²	0 - 3 ppm (0 - 3 mg/L)
Chloramine	0 - 3 ppm (0 - 3 mg/L)
Turbidity	0 - 10 NTU
Hardness ³	0 - 10 gpg
Iron	0 - 1 ppm (0 - 1 mg/L)
Bacterial Quality	Potable

AQUA FLO 75GPD HERO HIGH EFFICIENCY RO SYSTEM

With the quality of our drinking water increasingly coming under question, people are now looking for alternative sources of quality water. Reverse Osmosis Drinking Water Systems provide the most convenient and economical solution.

The HIGH EFFICIENCY REVERSE OSMOSIS (HERO) SYSTEM Virtually wastes no water with over 99.9% recovery.

Comparable systems typically waste 4-12 gallons for every gallon of RO water produced.



FEEL GREAT... HYDRATE!

75% WATER

- 75% of your body is water
- Mild dehydration can cause headaches, dizziness, fatigue, dry skin and joint pain
- 33% of caloric intake comes from sugary drinks
- Water has 0 calories and helps suppress hunger

Benefits:

- BLOOD NORMALIZER
- PRODUCTIVITY BOOST
- CLEARER SKIN
- BRAIN BOOST
- CALORIE CONTROL
- FATIGUE BUSTER
- FLUID BALANCE
- MUSCLE FUEL

Feed Water Guidelines	
Pressure	30 - 70 psi
Temperature	40 - 77 °F
Total Dissolved Solids (TDS) ¹	0 - 2500 ppm (0 - 2500 mg/L)
pH	5 - 10
Chlorine ²	0 - 3 ppm (0 - 3 mg/L)
Chloramine	0 - 3 ppm (0 - 3 mg/L)
Turbidity	0 - 10 NTU
Hardness ³	0 - 10 gpg
Iron	<0.2 ppm (<0.2 mg/l)
Bacterial Quality	Potable



This Membrane is Tested and Certified by NSF International against NSF/ANSI Standard 58 for material requirements only.

COMPONENT



Features:

- ➔ Heavy duty glass filled polypropylene construction provides double the strength, toughness & durability compared to most other RO's which are typically constructed with ABS.
- ➔ TFC 75 GPD reverse osmosis membrane provides up to 99% Total Dissolved Solids (TDS) rejection
- ➔ Pre-filters 10" five (5) micron Spun Polypropylene Sediment Cartridge and 10" Activated Carbon Cartridge
- ➔ Post filter: 10" Activated Carbon Cartridge
- ➔ Choose from air gap or non-air gap chrome plated faucets
- ➔ 3.0 Gallon NSF Certified plastic storage tank
- ➔ 3/8" outlet tubing for higher flows
- ➔ Automatic shut-off valve
- ➔ Exclusive serviceable check valve eliminates spring 'chatter' noise common in other RO's
- ➔ Quick connect fittings for ease of installation
- ➔ Powder coated bracket
- ➔ Dual purpose wrench for use on membrane cap and filter housing
- ➔ Dimensions: 15.0"w x 17.7"h x 6.9"d Pump Model

Model #	Part #	Stage 1	Stage 2	Stage 3	Stage 4	Storage Tank	Faucet
HERO	20010075	Sediment Filter	Activated Carbon Block Filter	Reverse Osmosis Membrane	Activated Carbon Polishing Filter	Plastic Tank - 3.8 Gallons	Chrome - Standard

Aqua Flo RO Filter Cartridge Replacement Kits

The **NEW Aqua Flo Filter Cartridge Replacement Kits** provide you with one convenient package for regularly required Aqua Flo Reverse Osmosis System filter changes. The Economy 4 and 5 Stage use 10" filters compatible with most competitive systems.



AQUA FLO®
PLATINUM

41407011
QCRO Reverse Osmosis
Filter Cartridge Replacement Kit

Kit contents:

- ➔ Two (2) Aqua Flo Platinum QCRO Carbon Block Replacement Filters (Item #41407002, QC Disposable)
- ➔ One (1) Aqua Flo Platinum QCRO Sediment Replacement Filter (Item #41407001, QC Disposable)



AQUA FLO®
PLATINUM

41407013
1240 Reverse Osmosis
Filter Cartridge Replacement Kit

Kit contents:

- ➔ Two (2) Aqua Flo Platinum 1240 Carbon Block Replacement Filters (Item #41400009, Blue Cap)
- ➔ One (1) Aqua Flo Platinum 1240 String Wound Sediment Replacement Filter (Item #41400008, Black Cap)
- ➔ One (1) Aqua Flo 1240 Sump Wrench (Item #21401240)



AQUA FLO®

41407012
475 Reverse Osmosis
Filter Cartridge Replacement Kit

Kit contents:

- ➔ Two (2) Aqua Flo 475 Carbon (Q Series COC-Purple) Replacement Filters (Item #65010088, QC Disposable)
- ➔ One (1) Aqua Flo 475 Sediment (Q Series Blue) Replacement Filter (Item #65010086, QC Disposable)



AQUA FLO®

60010688
4 Stage Reverse Osmosis
Filter Cartridge Replacement Kit

Kit contents:

- ➔ Two (2) Aqua Flo Carbon Block Replacement Filters (Item #26196, 2.5"x10", 10 Micron)
- ➔ One (1) Aqua Flo Spun Poly Bonded Sediment Replacement Filter (Item #26222, 2.5"x10", 5 Micron)
- ➔ One (1) Aqua Flo Sump Wrench (Item #60010691)



AQUA FLO®

60010717
H.E.R.O. Reverse Osmosis
Filter Cartridge Replacement Kit

Kit contents:

- ➔ Two (2) Aqua Flo Carbon Block Replacement Filters (Item #26196, 2.5"x10", 10 Micron)
- ➔ One (1) Aqua Flo Spun Poly Bonded Sediment Replacement Filter (Item #26222, 2.5"x10", 5 Micron)
- ➔ One (1) Aqua Flo Sump Wrench (Item #65030042)



AQUA FLO®

60010689
5 Stage Reverse Osmosis
Filter Cartridge Replacement Kit

Kit contents:

- ➔ Two (2) Aqua Flo Carbon Block Replacement Filters (Item #26196, 2.5"x10", 10 Micron)
- ➔ One (1) Aqua Flo Spun Poly Bonded Sediment Replacement Filter (Item #26222, 2.5"x10", 5 Micron)
- ➔ One (1) Aqua Flo In-Line GAC Replacement Filter (Item #92020, 2"x10", 1/4" QC)
- ➔ One (1) Aqua Flo Sump Wrench (Item#60010691)

Aqua Flo Residential Reverse Osmosis Membranes



AquaFlo residential reverse osmosis membranes provide reliable, consistent high quality performance at the lowest possible cost!



The component is Tested and Certified by NSF International against NSF/ANSI Standard 58 for material requirements only.

Features:

- ➔ **AquaFlo Platinum (NPI models)** made with high quality Polyamide Thin-Film Composite GE fabric (Made in the USA)
- ➔ **AquaFlo Value (NPD Models)** made with high quality Polyamide Thin-Film Composite house fabric
- ➔ Superior quality and cost savings
- ➔ 50, 75 & 100 GPD membranes
- ➔ Dry shipped for convenient handling and longer shelf life
- ➔ Individually inspected, qualified & vacuum tested
- ➔ Vacuum packaged, 25 membranes per case
- ➔ All membranes conform to NSF/ANSI Standard 58 for material requirements only
- ➔ Private label option (MOQ 300)

Advanced Technology:

- ➔ Fully automated, state-of-the-art production facility with 1,000,000 annual production capability
- ➔ Tightly controlled, sanitary environment. Strict temperature and moisture levels are maintained to ensure optimal quality



Aqua Flo Residential Reverse Osmosis Membranes



The component is Tested and Certified by NSF International against NSF/ANSI Standard 58 for material requirements only.

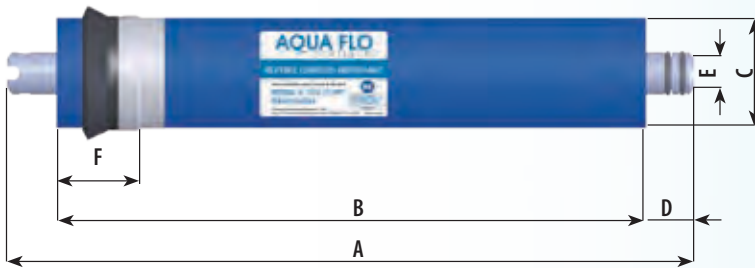

Model Terminology

Example of product type model specification : 1812-50-NPI

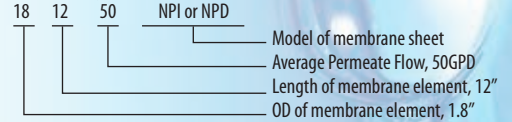

DIMENSIONS	A		B		C		D		E		F	
Type model	(in.)	(mm.)	(in.)	(mm.)	(in.)	(mm.)	(in.)	(mm.)	(in.)	(mm.)	(in.)	(mm.)
1812-50-NPI	11.74	298	10.08	256	1.65	42	0.83	21	0.67	17	1.38	35
1812-75-NPI	11.74	298	10.08	256	1.77	45	0.83	21	0.67	17	1.38	35
1812-50-NPD	11.74	298	10.08	256	1.65	42	0.83	21	0.67	17	1.38	35
1812-75-NPD	11.74	298	10.08	256	1.77	45	0.83	21	0.67	17	1.38	35

Product Specifications

Model	Applied Pressure		Permeate Flow Rate		Typical Stabilized Salt Rejection (%)
	(psig)	(bar)	GPD	(l/h)	
1812-50-NPI	60	4.14	50	7.9	96
1812-75-NPI	60	4.14	75	11.8	96
1812-50-NPD	60	4.14	50	7.9	96
1812-75-NPD	60	4.14	75	11.8	96

Operating & Cleaning Limits

Maximum Operating Temperature ¹	113°F (45°C)
Maximum Operating Pressure	150 psig (10 bar)
Maximum Feed Flow Rate	2.0 gpm (7.6 lpm)
pH Range, Continuous Operation ¹	2 - 11
Maximum Feed Silt Density Index (SDI)	SDI 5
Free Chlorine Tolerance ²	< 0.1 ppm

1. Maximum temperature for continuous operation above pH 10 is 95°F (35°C).
2. Under certain conditions, the presence of free chlorine and other oxidizing agents will cause premature membrane failure. Since oxidation damage is not covered under warranty, Canature WaterGroup Inc. recommends removing residual free chlorine by pre-treatment prior to membrane exposure.

Additional Important Information:

- ⊕ Inspect packaging is in good condition before usage. Store in cool, dry place out of direct sunlight. Avoid freezing.
- ⊕ It is recommended that systems using these elements rinse the elements for 24 hours, prior to first use, to meet NSF/ANSI 58 Standard.
- ⊕ The first full tank of permeate must be discarded. Do not use this initial permeate for drinking water or food preparation.
- ⊕ To ease installation, it is recommended to use a lubricant safe for indirect water contact on all seals. Potential options include water and glycerin based lubricants.
- ⊕ Rotate the element about a quarter turn to ease installation and removal of the element. Ensure good interface between the o-rings and brine seal with their connection surfaces.
- ⊕ Keep elements moist at all times after initial wetting.
- ⊕ To prevent biological growth during prolonged system shutdowns, it is recommended that membrane elements be immersed in a preservative solution. Rinse out the preservative before use.
- ⊕ The membrane shows some resistance to short-term attack by chlorine (hypochlorite). Continuous exposure, however, may damage the membrane and should be avoided.
- ⊕ If operating limits and guidelines given in this Product Information Bulletin are not strictly followed, the Limited 1 Year Warranty will be null and void. Use of any such chemicals or lubricants will void the Limited Warranty.

1. Permeate flow and salt rejection based on the following conditions: 250 ppm softened tap water, 77° F (25° C), 15% recovery and the specified applied pressure.
2. Minimum salt rejection is 96%
3. Permeate flows for individual elements may vary +/- 20%.

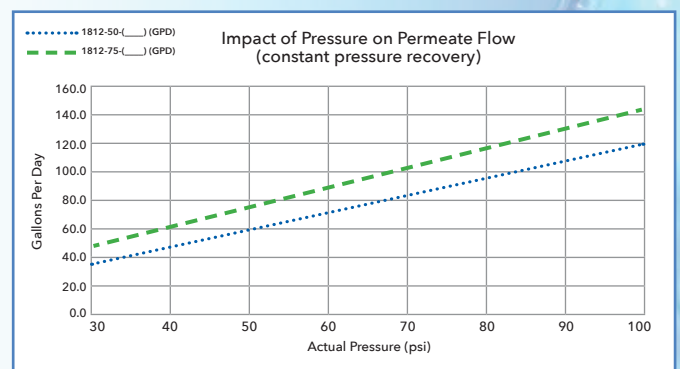
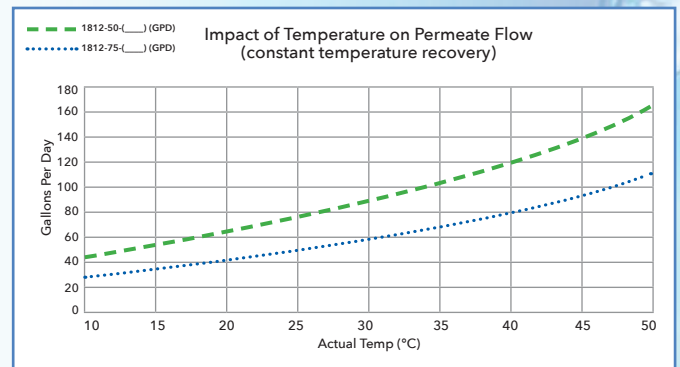

PART #	DESCRIPTION
RESIDENTIAL RO MEMBRANES (NSF CERTIFIED)	
AQUAFLO PLATINUM (GE Membrane sheet Made in USA)	
92035	AQFP-1812-50-NPI, 50 GPD TFC MEMBRANE NSF CERTIFIED
92022	AQFP-1812-75-NPI, 75 GPD TFC MEMBRANE NSF CERTIFIED
92092	AQFP-1812-100-NPI, 100 GPD TFC MEMBRANE NSF CERTIFIED
AQUAFLO VALUE	
92094	AQF-1812-50-NPD, 50 GPD TFC MEMBRANE NSF CERTIFIED
92095	AQF-1812-75-NPD, 75 GPD TFC MEMBRANE NSF CERTIFIED
92093	AQF-1812-100-NPD, 100 GPD TFC MEMBRANE NSF CERTIFIED

Designer RO Faucets

Designer RO faucets are a stylish addition to any kitchen. The NSF Certified lead-free ceramic disk faucets are available in many attractive finishes to coordinate with any decor. The faucets feature lead-free plastic water passages and lead-free brass gooseneck spouts that swivel 360 degrees for ease of use.

Specifications	VS888	VS905
Height	11.5" (292mm)	11.075" (281.32mm)
Spout Reach	5.7" (146mm)	4.75" (120mm)
Mounting Hole Diameter	1/2" (12.5mm)	1/2" (12.5mm)
Base Diameter	1.73" (44mm)	1.76" (44.8mm)
Connection	1/4" compression nut fitting	1/4" compression nut fitting
Operating Pressure	125 PSI/8.3BAR	125 PSI/8.3BAR
Flow Rate	1.0 gpm/3.785lpm @35 PSI/2.32BAR	1.0 gpm/3.785lpm @35 PSI/2.32BAR
Temp Rating	4°C/40°F to 70°C/158°F	4°C/40°F to 70°C/158°F
Warranty	2 Years	2 Years

* All mounting hardware included. A 3/8" quick connect faucet adapter fitting (#PP3212U7W) can be purchased separately.



VS905

VS888

**Color Sample Display
#87591**

PART #	DESCRIPTION
87588	Faucet, VS888, Antique Brass
87589	Faucet, VS888, Antique Wine
87581	Faucet, VS888, Brushed Nickel
87580	Faucet, VS888, Polished Chrome
87585	Faucet, VS888, Satin Nickel
87584	FAUCET, VS888, BLACK
70040045	Faucet, VS905, Antique Brass
70040054	Faucet, VS905, Antique Wine
87583	Faucet, VS905, Brushed Nickel
87587	Faucet, VS905, Oil Rubbed Bronze
87582	Faucet, VS905, Polished Chrome
87591	Faucet Colour Sample Display
92710	Stand, Display



RO Booster Pumps

PAB8800 Series High Flow Booster Pump

Key Operational Benefits:

- ➔ Boosts pressure 40 to 120 psi (adjustable)
- ➔ Used with membranes 50 to 120 GPD
- ➔ 15,000+ operating hours (estimated)
- ➔ Quiet – less than 52 DBA
- ➔ Can run dry without damage



Features:

- ➔ Toughest, most durable pump on the market
- ➔ Adjustable max. outlet psi (regardless of feed pressure)
- ➔ Expels trapped air (no more air locks)
- ➔ Can be mounted with pump head up or horizontal
- ➔ More flow at extremely low inlet pressures
- ➔ New motor venting system to remove moisture
- ➔ EMI/RFI electronic noise suppression
- ➔ 100% final performance tested
- ➔ Available in 12VDC and 24VDC

Aquatec 5800 Demand Pump

OPERATION: The 5800 pump can draw water from a holding tank and pressurize it, or boost the pressure from a low pressure source. They are designed to operate intermittently, but most versions can run continuously for several hour intervals. The pumps can be operated in demand mode controlled by an integral pressure switch, or in delivery mode controlled by an external power switching device. An integral bypass may be used to limit pressure.

POWER: 115V PSI: 60 GPM: 0.9

MOUNTING: A steel mounting base with four hollow rubber grommets is standard and included at no extra cost. The pump may be mounted in any position.

FITTINGS: The 5800 pump is offered with integral John Guest style quick connect fitting for 3/8" OD semi rigid tubing.



KemFlo MD1050 Booster Pump

DESCRIPTION: 110/230 VAC, 75 GPD Booster pump 1.0 L.min, suitable for applications with 24VDC transformer

SPECIFICATIONS: Kemflo MD Series booster pump with 3/8" FNPT, made from NSF grade material high power flow rate and quality. Meet ROHS standard.



Reverse Osmosis Storage Tanks

Flexwave is a line of RO accumulators and storage tanks for residential and light commercial applications.

Flexwave tanks are made in the USA and built to comply with NSF/ANSI Std 61. All Flexwave tanks have a 5 year warranty.



70031000 Quick Connect Ball Valve Assembly

reduces 1" tank connection to John Guest Quick Connect RO ball valve 3/8" tubing.

Larger sizes available. Please contact Customer Service for details.

Tank precharge 20 PSI

Maximum Pressure 125 PSI

Maximum working temperature, internal & external 120F

Materials of Construction

Tank top and bottom domes injection molded copolymer polypropylene. Shell extruded Polypropylene. Outer shell composite construction with fiberglass coated with epoxy resin. Base is injection molded high-impact ABS. 100% butyl diaphragm connected to a copolymer polypropylene bottom water chamber which allows for complete evacuation of the water chamber.

Dimensions & Capacities

Model	Item #	Total Tank Volume		Height		Diameter		Connection	Total Weight	
		Gallons	Litres	In	Cm	In	Cm		In	Lbs
FWRO15	33335	15 Gal	56.8	25.6	65	16.5	42	1" NPT	19	8.6
FWRO22	33336	22 Gal	83.3	34.1	87	16.5	42	1" NPT	25	11.3

Quick Sizing Chart

Model	Item #	Total Tank Volume		Total Drawdown			
				10/50		10/60	
		Gallons	Litres	Gallons	Litres	Gallons	Litres
FWRO15	33335	15 Gal	56.8	9.3	35.2	10	37.9
FWRO22	33336	22 Gal	83.3	13.6	51.5	14.7	55.6



AQUA FLO®

Aqua Flo
Ultraviolet
Disinfection
Systems



Aqua Flo Gen 4 Residential Systems: Genesis H2O: Ultraviolet Disinfection System

A Security System For Your Water

UV technology provides additional security for your water supply. It is proven to control microbiological (bacteria & virus) issues in water including *E.coli*, *Cryptosporidium*, and *Giardia Lamblia* without the use of chemicals.

Gen 4 Residential Systems

Features:

- Now available with integral lamp life monitor, with both audible and visual indication of lamp life
- Axial flow, 304 stainless steel, polished reactors
- Visual sight port for “lamp-on” verification
- Designed & manufactured to ASME pressure vessel standards
- Flow rates stated at 95% UVT at a dose of 30mJ/cm²
- User friendly bayonet style lamp connector (quick ¼ turn removal with no extra tools needed)
- True gland seal retaining nut with positive stop
- Reliable, industry proven low pressure (LP) coated UV lamps with ceramic bases for durability and a 9,000 hour life (1 year)
- Constant current electronic controller (one controller for all systems) in a splash-proof case with audible and visual lamp failure indicators
- New tactile selector button
- Warranty (refer to Owner’s Manual for complete details including conditions & exclusions):
 - Reactor Chamber - Ten (10) Year Limited
 - Electronics - Three (3) Year Limited
 - UV Lamps - One (1) Year Limited
 - Quartz Sleeves - One (1) Year Limited

Guidelines for Use

Parameter	Level
Hardness	< 7 gpg (120 mg/L)
Iron (Fe)	< 0.3ppm (mg/L)
Manganese (Mn)	< 0.05ppm (mg/L)
Tannins	< 0.1ppm (mg/L)
Turbidity	< 1 NTU
Transmittance (UVT)	> 75%

AQUA FLO®

Multi-Use / Residential systems (standard output lamps)

MODEL	GEN4-2 40030055	GEN4-3 40030056	GEN4-6 40030057	GEN4-10 40030058	GEN4-15 40030059	GEN4-20 40030060
Flow Rate 16mJ/cm ² @ 95% UVT	3.8 gpm 15 lpm 0.87 m ³ /hr	6.1 gpm 23 lpm 1.4 m ³ /hr	11 gpm 41 lpm 2.5 m ³ /hr	20 gpm 77 lpm 4.6 m ³ /hr	30 gpm 110 lpm 6.8 m ³ /hr	39 gpm 150 lpm 8.9 m ³ /hr
Flow Rate 30mJ/cm ² @ 95% UVT	2.0 gpm 7.7 lpm 0.46 m ³ /hr	3.1 gpm 11 lpm 0.70 m ³ /hr	5.8 gpm 23 lpm 1.3 m ³ /hr	11 gpm 41 lpm 2.5 m ³ /hr	15 gpm 57 lpm 3.4 m ³ /hr	21 gpm 79 lpm 4.8 m ³ /hr
Flow Rate 40mJ/cm ² @ 95% UVT	1.6 gpm 6.1 lpm 0.36 m ³ /hr	2.4 gpm 9.1 lpm 0.50 m ³ /hr	4.4 gpm 17 lpm 1.0 m ³ /hr	8.3 gpm 31 lpm 1.9 m ³ /hr	12 gpm 45 lpm 2.7 m ³ /hr	16 gpm 59 lpm 3.6 m ³ /hr
Port Size	½" FNPT	½" MNPT	¾" MNPT	¾" MNPT	1" MNPT	1" MNPT
Electrical	90-265V/50-60Hz. 1A Max.					
Lamp Power (Watts)	8	15	22	39	50	42
Power (Watts)	14	20	30	49	62	51
Replacement Lamp	40040113	40040013	40040014	40040015	40040017	40040016
Replacement Sleeve	40040039	40040040	40040043	40040045	40040047	40040046
Reactor Dimensions	6.4 x 26.2 cm (2.5 x 10.3")	6.4 x 36.4 cm (2.5 x 14.3")	6.4 x 54.2 cm (2.5 x 21.3")	6.4 x 89.5 cm (2.5 x 35.2")	6.4 x 101.6 cm (2.5 x 40.0")	8.9 x 91.7 cm (3.5 x 36.1")
Chamber Material	304 Stainless Steel, A249 Pressure Rated Tubing					
Controller Dimensions	17.2 x 9.2 x 10.2 cm (6.8 x 3.6 x 4")					
Operating Pressure	17.2 x 9.2 x 10.2 cm (6.8 x 3.6 x 4")					
Operating Water Temperature	2-40° C (36-104° F)					
Temperature Mgmt. Valve	NA	PN# 130131	PN# 130132		PN# 130133	
Cooling Fan	NO					OPTIONAL (40040009)
Lamp Change Reminder	YES					
Lamp Out Indicator	YES					
Shipping Weight	2.9 kg (6.3 lbs)	3.6 kg (7.9 lbs)	4.4 kg (9.6 lbs)	6.0 kg (13.2 lbs)	6.5 kg (14.4 lbs)	8.2 kg (18.0 lbs)

Sample Screens



NSF Certified Models Available. Contact Customer Service For Details.

Options



UV Sensor Module

Allows the 254nm UV wavelength to be measured and displayed via the GEN-4 controller.

REPLACEMENT PARTS

System	Lamps	Sleeves	Controller
Aqua Flo Gen 4-2	RL-290 #40040013	RQ-290 #40040039	RC-B4.01 #40040112
Aqua Flo Gen 4-3	RL-290 #40040013	RQ-290 #40040040	RC-B4.01 #40040112
Aqua Flo Gen 4-6	RL-470 #40040014	RQ-470 #40040043	RC-B4.01 #40040112
Aqua Flo Gen 4-11	RL-820 #40040015	RQ-820 #40040045	RC-B4.01 #40040112
Aqua Flo Gen 4-15	RL-999 #40040017	RQ-999 #40040048	RC-B4.01 #40040112
Aqua Flo Gen 4-21	RL-850 #40040016	RQ-850 #40040046	RC-B4.01 #40040112

Aqua Flo Gen H4 Residential Systems: Genesis H2O: Ultraviolet Disinfection System

A Security System For Your Water

UV technology provides additional security for your water supply. It is proven to control microbiological (bacteria & virus) issues in water including ***E.coli***, ***Cryptosporidium***, and ***Giardia Lamblia*** without the use of chemicals.

Gen H4 Residential Systems

Features:

- Now available with integral lamp life monitor, with both audible and visual indication of lamp life
- Axial flow, 304 stainless steel, polished reactors
- Visual sight port for “lamp-on” verification
- Designed & manufactured to ASME pressure vessel standards
- Flow rates stated at 95% UVT at a dose of 30mJ/cm2
- User friendly bayonet style lamp connector (quick ¼ turn removal with no extra tools needed)
- True gland seal retaining nut with positive stop
- Reliable, industry proven low pressure (LP) coated UV lamps with ceramic bases for durability and a 9,000 hour life (1 year)
- Constant current electronic controller (one controller for all systems) in a splash-proof case with audible and visual lamp failure indicators
- New tactile selector button
- Warranty (refer to Owner’s Manual for complete details including conditions & exclusions):
 - Reactor Chamber - Ten (10) Year Limited
 - Electronics - Three (3) Year Limited
 - UV Lamps - One (1) Year Limited
 - Quartz Sleeves - One (1) Year Limited



Guidelines for Use

Parameter	Level
Hardness	< 7 gpg (120 mg/L)
Iron (Fe)	< 0.3ppm (mg/L)
Manganese (Mn)	< 0.05ppm (mg/L)
Tannins	< 0.1ppm (mg/L)
Turbidity	< 1 NTU
Transmittance (UVT)	> 75%

AQUA FLO®

Residential Crossover systems (high output lamps)

MODEL	GENH4-5 40040076	GENH4-10 40040077	GENH4-15 40040078	GENH4-25 40040080	GENH4-40 40040081
Flow Rate 30mJ/cm ² @ 95% UVT	4.0 gpm	10 gpm	14 gpm	25 gpm	40 gpm
	15 lpm	38 lpm	53 lpm	95 lpm	150 lpm
	1.1 m ³ /hr	2.3 m ³ /hr	3.2 m ³ /hr	5.7m ³ /hr	9.1m ³ /hr
Flow Rate 40mJ/cm ² @ 95% UVT	3.0 gpm	7.0 gpm	11 gpm	19 gpm	31 gpm
	11 lpm	26 lpm	42 lpm	72 lpm	120 lpm
	0.68 m ³ /hr	1.6 m ³ /hr	2.5 m ³ /hr	4.3 m ³ /hr	7.0 m ³ /hr
Flow Rate Hot Water (-HW suffix) model 30mJ/cm ² @ 75% UVT	2.8 gpm	7.0 gpm	9.8 gpm	16 gpm	28 gpm
	11 lpm	26 lpm	37 lpm	61 lpm	110 lpm
	0.6 m ³ /hr	1.6 m ³ /hr	2.2 m ³ /hr	3.6 m ³ /hr	6.4 m ³ /hr
Flow Rate Low UVT (-50 suffix) model 30mJ/ cm ² @ 50% UVT	1.7 gpm	4.2 gpm	6.1 gpm	10 gpm	17 gpm
	6.4 lpm	16 lpm	23 lpm	38 lpm	64 lpm
	0.4 m ³ /hr	1.0 m ³ /hr	1.4 m ³ /hr	2.3 m ³ /hr	3.9 m ³ /hr
Flow Rate TOC (-TOC suffix) model 150mJ/ cm ² @ 98% UVT	0.8 gpm	2.0 gpm	2.8 gpm	5.1 gpm	8.0 gpm
	3.0 lpm	7.6 lpm	11 lpm	19 lpm	30 lpm
	0.2 m ³ /hr	0.5 m ³ /hr	0.6 m ³ /hr	1.1 m ³ /hr	1.8 m ³ /hr
Port Size	¾"MNPT	¾"MNPT	1"MNPT	1"MNPT	1 ½"MNPT
Electrical	90-265V/50-60Hz. 1.5A Max.				
Lamp Power (Watts)	18	34	45	67	101
Power (Watts)	20	36	48	72	108
Replacement Lamp	40040018	40040019	40040020	40040021	40040022
Replacement Sleeve	40040039	40040041	40040042	40040044	40040047
Reactor Dimensions	8.9 x 29.8 cm (3.5 x 11.7")	8.9 x 41.8 cm (3.5 x 16.5")	8.9 x 50.8 cm (3.5 x 20.0")	8.9 x 68.3 cm (3.5 x 26.9")	8.9 x 103.4 cm (3.5 x 40.7")
Chamber Material	316L Stainless Steel, A249 Pressure Rated Tubing				
Controller Dimensions	21.7 x 10.8 x 10.2 cm (8.6 x 4.2 x 4")				
Operating Pressure	0.7-10.3 bar (10-150 psi)				
Operating Water Temperature	2-40° C (36-104° F)				
Temperature Mgmt. Valve	PN# 40040099		PN# 40040100		PN# 40040101
Lamp Change Reminder	YES				
Lamp Out Indicator	YES				
Shipping Weight	4.4 kg (9.7 lbs)	5.2 kg (11.5 lbs)	5.6 kg (12.9 lbs)	7.0 kg (15.5 lbs)	9.6 kg (21.1 lbs)

Options



UV Sensor Module

Allows the 254nm UV wavelength to be measured and displayed via the GEN-H4 controller.

REPLACEMENT PARTS

System	Lamps	Sleeves	Controller
Aqua Flo Gen H4-5	RL-290	RQ-290	RC-B4.01
	#40040018	#40040039	#40040112
Aqua Flo Gen H4-10	RL-290	RQ-290	RC-B4.01
	#40040019	#40040041	#40040112
Aqua Flo Gen H4-15	RL-470	RQ-470	RC-B4.01
	#40040020	#40040042	#40040112
Aqua Flo Gen H4-25	RL-820	RQ-820	RC-B4.01
	#40040021	#40040044	#40040112
Aqua Flo Gen H4-40	RL-999	RQ-999	RC-B4.01
	#40040022	#40040047	#40040112

Aqua Flo Gen 5 Residential Systems: Genesis H2O: Ultraviolet Disinfection System

A Security System For Your Water

UV technology provides additional security for your water supply. It is proven to control microbiological (bacteria & virus) issues in water including *E.coli*, *Cryptosporidium*, and *Giardia Lamblia* without the use of chemicals.

Gen 5 Residential Systems

Features:

- Five models available (Gen5-3, 6, 10, 15 & 20)
- Colour user interface with full diagnostics and warnings including QR codes
- "Future-proof" expandability port for future upgrades and options
- Designed & manufactured to ASME pressure vessel standards
- Axial flow, 316L stainless steel reactor, polished reactors with integral sensor port to allow for sensor upgradeability in the future (comes standard with visual glow plug)
- Flow rates stated at 95% UVT at a dose of 30mJ/cm²
- User friendly bayonet style lamp connector (Quick ¼ turn removal. No extra tools required.)
- Reliable, industry proven low pressure (LP) coated UV lamps with ceramic bases for durability and a 9000 hour life (1 year)
- Constant current electronic controller (one controller for all systems) in a splash-proof case
- Warranty (refer to Owner's Manual for complete details including conditions & exclusions):
 - Reactor Chamber - Ten (10) Year Limited
 - Electronics - Three (3) Year Limited
 - UV Lamps - One (1) Year Limited
 - Quartz Sleeves - One (1) Year Limited



AQUA FLO®

Guidelines for Use

Parameter	Level
Hardness	< 7 gpg (120 mg/L)
Iron (Fe)	< 0.3ppm (mg/L)
Manganese (Mn)	< 0.05ppm (mg/L)
Tannins	< 0.1ppm (mg/L)
Turbidity	< 1 NTU
Transmittance (UVT)	> 75%



AQUA FLO GEN EQUIPMENT SPECIFICATIONS

AQUA FLO GEN-5, Residential UV systems

MODEL	GEN5-3 40030001	GEN5-6 40030002	GEN5-10 40030003	GEN5-15 40030004	GEN5-20 40030005
Flow Rate (@ 16 mJ/cm ² @ 95% UVT)	6 GPM 23 lpm 1.4 m ³ /hr.	11 GPM 41 lpm 2.5 m ³ /hr.	20 GPM ¹ 77 lpm ¹ 4.6 m ³ /hr. ¹	30 GPM ² 113.6 lpm ² 6.8 m ³ /hr. ²	39.2 GPM ² 150 lpm ² 8.9 m ³ /hr. ²
Flow Rate (@ 30 mJ/cm ² @ 95% UVT)	3 GPM 11.4 lpm 0.7 m ³ /hr.	6 GPM 22.7 lpm 1.4 m ³ /hr.	11 GPM 41 lpm 2.5 m ³ /hr.	15 GPM 56.8 lpm 3.4 m ³ /hr.	21 GPM 79 lpm 4.8 m ³ /hr.
Flow Rate (@ 40 mJ/cm ² @ 95% UVT)	2.4 GPM 9.1 lpm 0.5 m ³ /hr.	4.4 GPM 17 lpm 1.0 m ³ /hr.	8.3 GPM 31 lpm 1.9 m ³ /hr.	12 GPM 45.4 lpm 2.7 m ³ /hr.	16 GPM 59 lpm 3.6 m ³ /hr.
Port Size	½" MNPT	¾" MNPT	¾" MNPT	1" MNPT	1" MNPT
Electrical	90-265V/50-60Hz.				
Plug Type	North American, NEMA 5-15, 3-wire for all 110V				
Lamp Watts	15	22	39	50	42
Power (watts)	20	30	49	62	51
Replacement Lamp	RL-290	RL-470	RL-820	RL-999	RL-850
Replacement Sleeve	RQ-290	RQ-470	RQ-820	RQ-999	RQ-850
Reactor Dimensions	2.5 x 14.3" (6.4 x 36.4 cm)	2.5 x 21.3" (6.4 x 54.2 cm)	2.5 x 35.2" (6.4 x 89.5 cm)	2.5 x 40.0" (6.4 x 101.6 cm)	3.5 x 36.1" (8.9 x 91.7 cm)
Chamber Material	Polished 304 Stainless Steel, A249 Pressure Rated Tubing				
Controller Dimensions	6.8 x 3.6 x 3" (171.5 x 92.1 x 76.2 mm)				
Operating Pressure	0.7-10.3 bar (10-150 psi)				
Operating Water Temperature	2-40° C (36-104° F)				
UV Monitor Port (upgradeability)	No	Yes			
Solenoid Output	Yes, but requires optional solenoid module				
4-20 mA Output	Yes, but requires optional 4-20 mA module				
Lamp Change Reminder (audible & visual)	Yes				
Lamp-Out Indicator (audible & visual)	Yes				
Shipping Weight	3.3 kg. (7.3 lbs.) 3 kg. (7 lbs.) cubed	4.2 kg. (9.3 lbs.) 5 kg. (9 lbs.) cubed	6.8 kg. (15.0 lbs.) 7 kg. (15 lbs.) cubed	8.0 kg. (17.6 lbs.) 8 kg. (17 lbs.) cubed	7.5 kg. (16.5 lbs.) 10 kg. (22 lbs.) cubed
Note: 1. based on flow velocity of 8.2 ft/sec (2.5 m/sec.), flow rate limited to 13.6 gpm (50 lpm) (3.1 m ³ /hr.) for ¾" port 2. based on flow velocity of 8.2 ft/sec (2.5 m/sec.), flow rate limited to 22.1 gpm (84 lpm) (5.0 m ³ /hr.) for 1" port					

Sample Screens



NSF Certified Models Available. Contact Customer Service For Details.

Options



UV Sensor Module

Allows the 254nm UV wavelength to be measured and displayed via the GEN-5 controller. The sensor plugs directly into the controller and is mounted in the sensor port located on all GEN-5 units.



Solenoid Module

Used to power a remote normally closed solenoid valve (not included). Solenoid valve will close on lamp failure or when low UV conditions are detected by the sensor. Available in 110V MODSOL1 (Item # 40040006)

REPLACEMENT PARTS

System	Lamps	Sleeves	Controller
Aqua Flo Gen 5-3	RL-290 #40040013	RQ-290 #40040040	RC-B56.01 #40040066
Aqua Flo Gen 5-6	RL-470 #40040014	RQ-470 #40040043	RC-B56.01 #40040066
Aqua Flo Gen 5-10	RL-820 #40040015	RQ-820 #40040045	RC-B56.01 #40040066
Aqua Flo Gen 5-15	RL-999 #40040017	RQ-999 #40040048	RC-B56.01 #40040066
Aqua Flo Gen 5-20	RL-850 #40040016	RQ-850 #40040046	RC-B56.01 #40040066

Aqua Flo Gen H5 Residential Crossover High Flow Systems

A Security System For Your Water

UV technology provides additional security for your water supply. It is proven to control microbiological (bacteria & virus) issues in water including *E.coli*, *Cryptosporidium*, and *Giardia Lamblia* without the use of chemicals.

Gen H5 Residential Crossover High Flow Systems

Features:

- Five models available (Gen H5-5, 10, 15, 25 & 40)
- Colour user interface with full diagnostics and warnings including QR codes
- “Future-proof” expandability port for future upgrades and options
- Axial flow, 316L stainless steel reactor, polished reactors with integral sensor port to allow for sensor upgradeability in the future (comes standard with visual glow plug)
- Designed & manufactured to ASME pressure vessel standards
- Flow rates stated at 95% UVT at a dose of 30mJ/cm²
- User friendly bayonet style lamp connector (Quick ¼ turn removal. No extra tools required.)
- True gland seal retaining nut with positive stop
- Reliable, industry proven low pressure, high-output (LP-HO) coated UV lamps with ceramic bases for durability and a 10,000 hour life
- Universal input, constant current electronic controller (one controller for all systems) in a splash-proof case
- Warranty (refer to Owner’s Manual for complete details including conditions & exclusions):
 - Reactor Chamber - Ten (10) Year Limited
 - Electronics - Three (3) Year Limited
 - UV Lamps - One (1) Year Limited
 - Quartz Sleeves - One (1) Year Limited



AQUA FLO®

Guidelines for Use

Parameter	Level
Hardness	< 7 gpg (120 mg/L)
Iron (Fe)	< 0.3ppm (mg/L)
Manganese (Mn)	< 0.05ppm (mg/L)
Tannins	< 0.1ppm (mg/L)
Turbidity	< 1 NTU
Transmittance (UVT)	> 75%

MODEL	GENH5-5 40030010	GENH5-10 40030011	GENH5-15 40030012	GENH5-25 40030013	GENH5-40 40030014
Flow Rate (Industry Standard)	4 GPM 15.1 lpm 0.9 m ³ /hr.	10 GPM 37.9 lpm 2.3 m ³ /hr.	14 GPM 53 lpm 3.2 m ³ /hr.	25 GPM ² 95 lpm 5.7 m ³ /hr.	40 GPM 151 lpm 9.1 m ³ /hr.
Alternate flow @ 16 mJ/cm ² (US Public Health)	8 GPM 30.3 lpm 1.8 m ³ /hr.	19 GPM ¹ 71.9 lpm 4.3 m ³ /hr.	27 GPM ² 102.2 lpm 6.1 m ³ /hr.	47 GPM ² 178 lpm 10.7 m ³ /hr.	78 GPM ³ 295 lpm 17.7 m ³ /hr.
Alternate flow @ 40 mJ/cm ² (NSF/EPA)	3 GPM 11.4 lpm 0.7 m ³ /hr.	7 GPM 26.5 lpm 1.6 m ³ /hr.	11 GPM 41 lpm 2.5 m ³ /hr.	19 GPM 72 lpm 4.3 m ³ /hr.	31 GPM 117 lpm 7 m ³ /hr.
Port Size	½" MNPT	¾" MNPT	1" MNPT	1" MNPT	1½" MNPT
Electrical	90-265V/50-60Hz. (IEC power cords required)				
Power Plug	North American, NEMA 5-15, 3-wire for all 110V				
Lamp Watts	18	34	45	67	101
Power (watts)	20 (19 @ 230V.)	38 (36 @ 230V.)	57 (48 @ 230V.)	73 (72 @ 230V.)	115 (108 @ 230V.)
Replacement Lamp	RL-210HO	RL-330HO	RL-420HO	RL-600HO	RL-950HO
Replacement Sleeve	RQ-210	RQ-330	RQ-420	RQ-600	RQ-950
Reactor Dimensions	3.5 x 11.7" (8.9 x 29.8 cm)	3.5 x 16.5" (8.9 x 41.8 cm)	3.5 x 20.0" (8.9 x 50.8 cm)	3.5 x 26.9" (8.9 x 68.3 cm)	3.5 x 40.7" (8.9 x 103.4 cm)
Chamber Material	316L Stainless Steel, A249 Pressure Rated Tubing, Polished & Passivated				
Controller Dimension	8.6 x 4.2 x 3.5" (217.4 x 107.5 x 88.7 mm)				
Operating Pressure	0.7-10.3 bar (10-150 psi)				
Optimum Water Temperature	2-40° C (36-104° F)				
UV Monitor Port (upgradeability)	Yes, includes visual glow plug				
Solenoid Output	Yes, but requires optional solenoid module				
4-20 mA Output	Yes, but requires optional 4-20 mA module				
Lamp Change Reminder (audible & visual)	Yes				
Lamp-Out Indicator (audible & visual)	Yes				
Shipping Weight	4.5 kg. (9.9 lbs.) 4 kg. (8 lbs.) cubed	5.4 kg. (11.9 lbs.) 5 kg. (11 lbs.) cubed	6.0 kg. (13.2 lbs.) 6 kg. (13 lbs.) cubed	7.2 kg. (15.9 lbs.) 8 kg. (16 lbs.) cubed	9.7 kg. (21.4 lbs.) 11 kg. (24 lbs.) cubed
<p>Note: 1. based on flow velocity of 8.2 ft/sec (2.5 m/sec.), flow rate limited to 13.6 gpm (50 lpm) (3.1 m³/hr.) for 3/4" port</p> <p>2. based on flow velocity of 8.2 ft/sec (2.5 m/sec.), flow rate limited to 22.1 gpm (84 lpm) (5.0 m³/hr.) for 1" port</p> <p>3. based on flow velocity of 8.2 ft/sec (2.5 m/sec.), flow rate limited to 52 gpm (197 lpm) (11.8 m³/hr.) for 1 ½" port</p>					

Sample Screens

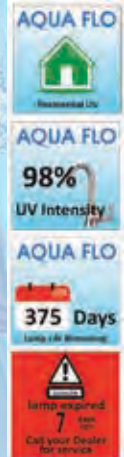

NSF Certified Models Available. Contact Customer Service For Details.

Options



UV Sensor Module

Allows the 254nm UV wavelength to be measured and displayed via the GEN-H5 controller. The sensor plugs directly into the controller and is mounted in the sensor port located on all PURA Gen H5 units.



Solenoid Module

Used to power a remote normally closed solenoid valve (not included). Solenoid valve will close on lamp failure or when low UV conditions are detected by the sensor. Available in 110V MODSOL1 (Item # 40040006)

REPLACEMENT PARTS

System	Lamps	Sleeves	Controller
Pura Gen H5-5	RL-210HO #40040018	RQ-210 #40040039	RCHO-B56.12 #40040074
	RL-330HO #40040019	RQ-330 #40040041	RCHO-B56.12 #40040074
Pura Gen H5-10	RL-420HO #40040020	RQ-420 #40040042	RCHO-B56.12 #40040074
	RL-600HO #40040021	RQ-600 #40040044	RCHO-B56.12 #40040074
Pura Gen H5-25	RL-950HO #40040022	RQ-950 #40040047	RCHO-B56.12 #40040074

Aqua Flo Gen 6 Residential Systems

A Security System For Your Water

UV technology provides additional security for your water supply. It is proven to control microbiological (bacteria & virus) issues in water including *E.coli*, *Cryptosporidium*, and *Giardia Lamblia* without the use of chemicals.

Gen 6 Residential Systems

Features:

- Four models available (Gen 6-6 , 10, 15 & 20)
- True 254nm Teflon® based UV sensor continuously measures UV output and visually displays output via controller
- Colour user interface with full diagnostics and warnings including QR codes
- “Future-proof” expandability port for future upgrades and options
- Axial flow, 304 stainless reactors
- Designed & manufactured to ASME pressure vessel standards
- Flow rates stated at 95% UVT at a dose of 30mJ/cm2
- User friendly bayonet style lamp connector (Quick ¼ turn removal. No extra tools required.)
- True gland seal retaining nut with positive stop
- Reliable, industry proven low pressure (LP) coated UV lamps with ceramic bases for durability and a 9000 hour life (1 year)
- Constant current electronic controller (one controller for all systems) in a splash-proof case
- Warranty (refer to Owner’s Manual for complete details including conditions & exclusions):
 - Reactor Chamber - Ten (10) Year Limited
 - Electronics - Three (3) Year Limited
 - UV Lamps - One (1) Year Limited
 - Quartz Sleeves - One (1) Year Limited
 - UV Sensors - One (1) Year Limited



Guidelines for Use

Parameter	Level
Hardness	< 7 gpg (120 mg/L)
Iron (Fe)	< 0.3ppm (mg/L)
Manganese (Mn)	< 0.05ppm (mg/L)
Tannins	< 0.1ppm (mg/L)
Turbidity	< 1 NTU
Transmittance (UVT)	> 75%

AQUA FLO®

MODEL	GEN6-6 40030006	GEN6-10 40030007	GEN6-15 40030008	GEN6-20 40030009
UV Flow Rate (@ 16 mJ/cm ² @ 95% UVT)	11 GPM 41 lpm 2.5 m ³ /hr.	20 GPM ¹ 77 lpm ¹ 4.6 m ³ /hr. ¹	30 GPM ² 113.6 lpm ² 6.8 m ³ /hr. ²	39.2 GPM ² 150 lpm ² 8.9 m ³ /hr. ²
UV Flow Rate (@ 30 mJ/cm ² @ 95% UVT)	6 GPM 22.7 lpm 1.4 m ³ /hr.	11 GPM 41 lpm 2.5 m ³ /hr.	15 GPM 56.8 lpm 3.4 m ³ /hr.	21 GPM 79 lpm 4.8 m ³ /hr.
UV Flow Rate (@ 40 mJ/cm ² @ 95% UVT)	4.4 GPM 17 lpm 1.0 m ³ /hr.	8.3 GPM 31 lpm 1.9 m ³ /hr.	12 GPM 45.4 lpm 2.7 m ³ /hr.	16 GPM 59 lpm 3.6 m ³ /hr.
Port Size	¾" MNPT	¾" MNPT	1" MNPT	1" MNPT
Electrical	90-265V/50-60Hz.			
Plug Type	North American, NEMA 5-15, 3-wire for all 110V			
Lamp Watts	22	39	50	42
Power (watts)	30	49	62	51
Replacement Lamp	RL-470	RL-820	RL-999	RL-850
Replacement Sleeve	RQ-470	RQ-820	RQ-999	RQ-850
Reactor Dimensions	2.5 x 21.3" (6.4 x 54.2 cm)	2.5 x 35.2" (6.4 x 89.5 cm)	2.5 x 40.0" (6.4 x 101.6 cm)	3.5 x 36.1" (8.9 x 91.7 cm)
Chamber Material	Polished 304 Stainless Steel, A249 Pressure Rated Tubing			
Controller Dimensions	6.8 x 3.6 x 3" (171.5 x 92.1 x 76.2 mm)			
Operating Pressure	0.7-10.3 bar (10-150 psi)			
Operating Water Temperature	2-40° C (36-104° F)			
UV Intensity Monitor	Yes			
Solenoid Output	Yes, but requires optional solenoid module			
4-20 mA Output	Yes, but requires optional 4-20 mA module			
Lamp Change Reminder (audible & visual)	Yes			
Lamp-Out Indicator (audible & visual)	Yes			
Shipping Weight	4.2 kg. (9.3 lbs.) 5 kg. (9 lbs.) cubed	6.8 kg. (15.0 lbs.) 7 kg. (15 lbs.) cubed	8.0 kg. (17.6 lbs.) 8 kg. (17 lbs.) cubed	7.5 kg. (16.5 lbs.) 10 kg. (22 lbs.) cubed
Note: 1. based on flow velocity of 8.2 ft/sec (2.5 m/sec.), flow rate limited to 13.6 gpm (50 lpm) (3.1 m ³ /hr.) for ¾" port 2. based on flow velocity of 8.2 ft/sec (2.5 m/sec.), flow rate limited to 22.1 gpm (84 lpm) (5.0 m ³ /hr.) for 1" port				

Sample Screens



NSF Certified Models Available. Contact Customer Service For Details.

Options



UV Sensor Module

Allows the 254nm UV wavelength to be measured and displayed via the GEN-H6 controller. The sensor plugs directly into the controller and is mounted in the sensor port located on all PURA Gen 6 units.



Solenoid Module

Used to power a remote normally closed solenoid valve (not included). Solenoid valve will close on lamp failure or when low UV conditions are detected by the sensor. Available in 110V MODSOL1 (Item # 40040006)

REPLACEMENT PARTS

System	Lamps	Sleeves	Controller
Aqua Flo Gen 6-6	RL-470 #40040014	RQ-470 #40040043	RC-B56.01 #40040066
	RL-820 #40040015	RQ-820 #40040045	RC-B56.01 #40040066
Aqua Flo Gen 6-15	RL-999 #40040017	RQ-999 #40040048	RC-B56.01 #40040066
	RL-850 #40040016	RQ-850 #40040046	RC-B56.01 #40040066

Aqua Flo Gen H6 Residential Crossover High Flow Systems

A Security System For Your Water

UV technology provides additional security for your water supply. It is proven to control microbiological (bacteria & virus) issues in water including *E.coli*, *Cryptosporidium*, and *Giardia Lamblia* without the use of chemicals.

Gen H6 Residential Crossover High Flow Systems

Features:

- Five models available (Gen H6-5, 10, 15, 25 & 40)
- True 254nm Teflon® based UV sensor continuously measures UV output via the controller
- Colour user interface with full diagnostics and warnings including QR codes
- “Future-proof” expandability port for future upgrades and options
- Axial flow, 316L stainless steel reactor
- Designed & manufactured to ASME pressure vessel standards
- Flow rates stated at 95% UVT at a dose of 30mJ/cm²
- User friendly bayonet style lamp connector (Quick ¼ turn removal. No extra tools required.)
- True gland seal retaining nut with positive stop
- Reliable, industry proven low pressure, high-output (LP-HO) coated UV lamps with ceramic bases for durability and a 10,000 hour life
- Universal input, constant current electronic controller (one controller for all systems) in a splash-proof case
- Warranty (refer to Owner’s Manual for complete details including conditions & exclusions):
 - Reactor Chamber - Ten (10) Year Limited
 - Electronics - Three (3) Year Limited
 - UV Lamps - One (1) Year Limited
 - Quartz Sleeves - One (1) Year Limited
 - UV Sensors - One (1) Year Limited



Guidelines for Use

Parameter	Level
Hardness	< 7 gpg (120 mg/L)
Iron (Fe)	< 0.3ppm (mg/L)
Manganese (Mn)	< 0.05ppm (mg/L)
Tannins	< 0.1ppm (mg/L)
Turbidity	< 1 NTU
Transmittance (UVT)	> 75%

AQUA FLO®

MODEL	GENH6-5 40030015	GENH6-10 40030016	GENH6-15 40030017	GENH6-25 40030018	GENH6-40 40030019
Flow Rate (Industry Standard)	4 GPM 15.1 lpm 0.9 m ³ /hr.	10 GPM 37.9 lpm 2.3 m ³ /hr.	14 GPM 53 lpm 3.2 m ³ /hr.	25 GPM ² 95 lpm 5.7 m ³ /hr.	40 GPM 151 lpm 9.1 m ³ /hr.
Alternate flow @ 16 mJ/cm ² (US Public Health)	8 GPM 30.3 lpm 1.8 m ³ /hr.	19 GPM ¹ 71.9 lpm 4.3 m ³ /hr.	27 GPM ² 102.2 lpm 6.1 m ³ /hr.	47 GPM ² 178 lpm 10.7 m ³ /hr.	78 GPM ³ 295 lpm 17.7 m ³ /hr.
Alternate flow @ 40 mJ/cm ² (NSF/EPA)	3 GPM 11.4 lpm 0.7 m ³ /hr.	7 GPM 26.5 lpm 1.6 m ³ /hr.	11 GPM 41 lpm 2.5 m ³ /hr.	19 GPM 72 lpm 4.3 m ³ /hr.	31 GPM 117 lpm 7 m ³ /hr.
Port Size	½" MNPT	¾" MNPT	1" MNPT	1" MNPT	1½" MNPT
Electrical	90-265V/50-60Hz. (IEC power cords required)				
Power Plug	North American, NEMA 5-15, 3-wire for all 110V				
Lamp Watts	18	34	45	67	101
Power (watts)	20 (19 @ 230V.)	38 (36 @ 230V.)	57 (48 @ 230V.)	73 (72 @ 230V.)	115 (108 @ 230V.)
Replacement Lamp	RL-210HO	RL-330HO	RL-420HO	RL-600HO	RL-950HO
Replacement Sleeve	RQ-210	RQ-330	RQ-420	RQ-600	RQ-950
Reactor Dimensions	3.5 x 11.7" (8.9 x 29.8 cm)	3.5 x 16.5" (8.9 x 41.8 cm)	3.5 x 20.0" (8.9 x 50.8 cm)	3.5 x 26.9" (8.9 x 68.3 cm)	3.5 x 40.7" (8.9 x 103.4 cm)
Chamber Material	316L Stainless Steel, A249 Pressure Rated Tubing, Polished & Passivated				
Controller Dimension	8.6 x 4.2 x 3.5" (217.4 x 107.5 x 88.7 mm)				
Operating Pressure	0.7-10.3 bar (10-150 psi)				
Optimum Water Temperature	2-40° C (36-104° F)				
UV Intensity Monitor	Yes				
Solenoid Output	Yes, but requires optional solenoid module				
4-20 mA Output	Yes, but requires optional 4-20 mA module				
Lamp Change Reminder (audible & visual)	Yes				
Lamp-Out Indicator (audible & visual)	Yes				
Shipping Weight	4.5 kg. (9.9 lbs.) 4 kg. (8 lbs.) cubed	5.4 kg. (11.9 lbs.) 5 kg. (11 lbs.) cubed	6.0 kg. (13.2 lbs.) 6 kg. (13 lbs.) cubed	7.2 kg. (15.9 lbs.) 8 kg. (16 lbs.) cubed	9.7 kg. (21.4 lbs.) 11 kg. (24 lbs.) cubed
Note: 1. based on flow velocity of 8.2 ft/sec (2.5 m/sec.), flow rate limited to 13.6 gpm (50 lpm) (3.1 m ³ /hr.) for 3/4" port 2. based on flow velocity of 8.2 ft/sec (2.5 m/sec.), flow rate limited to 22.1 gpm (84 lpm) (5.0 m ³ /hr.) for 1" port 3. based on flow velocity of 8.2 ft/sec (2.5 m/sec.), flow rate limited to 52 gpm (197 lpm) (11.8 m ³ /hr.) for 1 ½" port					

Sample Screens

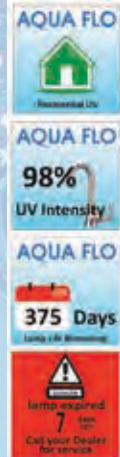

NSF Certified Models Available. Contact Customer Service For Details.

Options



UV Sensor Module

Allows the 254nm UV wavelength to be measured and displayed via the GENH-6 controller. The sensor plugs directly into the controller and is mounted in the sensor port located on all GenH6 units.



Solenoid Module

Used to power a remote normally closed solenoid valve (not included). Solenoid valve will close on lamp failure or when low UV conditions are detected by the sensor. Available in 110V MODSOLI (Item # 40040006)

REPLACEMENT PARTS

System	Lamps	Sleeves	Controller
Aqua Flo Gen H6-5	RL-210HO #40040018	RQ-210 #40040039	RCHO-B56.12 #40040074
Aqua Flo Gen H6-10	RL-330HO #40040019	RQ-330 #40040041	RCHO-B56.12 #40040074
Aqua Flo Gen H6-15	RL-420HO #40040020	RQ-420 #40040042	RCHO-B56.12 #40040074
Aqua Flo Gen H6-25	RL-600HO #40040021	RQ-600 #40040044	RCHO-B56.12 #40040074
Aqua Flo Gen H6-40	RL-950HO #40040022	RQ-950 #40040047	RCHO-B56.12 #40040074

Aqua Flo Gen 4 UV/Filter Rack System

A Combination Water System For Your Entire Home or Cottage

Combining ultraviolet disinfection (UV) with whole-house filtration provides your home or cottage with clean, great-tasting water that you can rely on. UV is proven to control microbiological (bacteria & virus) issues in water including ***E.coli***, ***Cryptosporidium***, and ***Giardia Lamblia*** without the use of chemicals. Combining UV disinfection with whole-house sediment and/or carbon pre-treatment filters improves UV performance and the taste, smell and clarity of your water.

Features:

- Four models provide a range of flow rate and filter combination options suitable for your specific needs
- **NEW** filter design, includes new one-piece, 2-sump design for leak free operation, (pressure relief, wrench, and new integral hanging clip included with all systems)
- **NEW** LED lamp countdown (4.1 variants)
- **NEW** controller with Lightlock™ technology for protected lamp sales (5.1 variants)
- Universal mounting configuration (left or right access)
- NSF component listed filtration cartridges (included with systems)
- “Future-proof” expandability port for future upgrades and options
- Axial flow, 316L stainless steel polished reactors, fully polished, designed & manufactured to ASME pressure vessel standards
- Reliable, industry proven, coated UV lamps, (9,000 hour life on LB4/5 series and 10,000 hour life on LBH4/5 series)
- Full customization available as an option (language, home screen, phone, QR codes, etc.)



AQUA FLO®

Guidelines for Use

Parameter	Level
Hardness	< 7 gpg (120 mg/L)
Iron (Fe)	< 0.3ppm (mg/L)
Manganese (Mn)	< 0.05ppm (mg/L)
Tannins	< 0.1ppm (mg/L)
Turbidity	< 1 NTU
Transmittance (UVT)	> 75%

AQUA FLO GEN-4, UV/Filter Rack System

MODEL	GEN4-8R1 40030061N	GEN4-8R12 40030062N	GEN4-13R2 40030063N	GEN4-13R22 40030064N
Flow Rate (@ 30 mJ/cm ² @ 95% UVT)	8.0 GPM	8.0 GPM	13.0 GPM ²	13 GPM ²
	30 lpm	30 lpm	49.2 lpm ²	49.2 lpm ²
	1.8 m ³ /hr.	1.8 m ³ /hr.	2.95 m ³ /hr. ²	2.95 m ³ /hr. ²
1st Filter Housing	10" 5 Micron Sediment 26235	10" 5 Micron Sediment 26235	20" 5 Micron Sediment 26239	20" 5 Micron Sediment 26239
2nd Filter Housing	N/A	20" High Capacity Carbon 26256	N/A	20" High Capacity Carbon 26256
Port Size	1" MNPT			
Electrical	90-265V/50-60Hz.			
Plug Type	American, Nema 5/15, 3 wire for all 110V systems, "1" suffix (i.e. LB5-Z1) European, CEE 7/7, 3 wire for all 230V systems, "2" suffix (i.e. LB5-Z1-2) British Standard, BS 1363, 3 wire for all 230V systems, "3" suffix (i.e. LB5-Z1-3) Australian/New Zealand, AS/NZ 3112, 3 wire for all 230V systems, "4" suffix (i.e. LB5-Z1-4)			
Lamp Watts	20 (Standard-Output Lamp)		45 (High-Output Lamp)	
Power (watts)	23 (21 @ 230V.)		57 (48 @ 230V.)	
Max Current (amps)	1			
Chamber Dimensions	6.8 x 3.6 x 3" (17.2x9.2x7.6 cm)		8.6 x 4.2 x 3.5" (21.7x10.8x8.9 cm)	
Chamber Material	Polished 316L stainless steel, A249 pressure rated tubing			
Controller Dimensions	6.8 x 3.6 x 3" (171.5 x 92.1 x 76.2 mm)		8.6 x 4.2 x 3.5" (21.7 x 10.8 x 8.9 cm)	
Operating Pressure	0.7-10.3 bar (10-150 psi)			
Operating Water Temperature	2-40° C (36-104° F)			
Lamp Change Reminder (Audible & Visual)	Yes			
Lamp-Out Indicator (Audible & Visual)	Yes			
Shipping Weight	8.0 kg. (17.6 lbs.)	16.6 kg. (36.6 lbs.)	15.2 kg. (33.5 lbs.)	15.2 kg. (33.5 lbs.)

Note: 1. based on flow velocity of 8.2 ft/sec (2.5 m/sec.), flow rate limited to **13.6 gpm** (50 lpm) (3.1 m³/hr.) for 3/4" port
2. based on flow velocity of 8.2 ft/sec (2.5 m/sec.), flow rate limited to **22.1 gpm** (84 lpm) (5.0 m³/hr.) for 1" port

Sample Screens



NSF Certified Models Available. Contact Customer Service For Details.

Options



UV Sensor Module

Allows the 254nm UV wavelength to be measured and displayed via the GEN-4 UV controller.

REPLACEMENT PARTS

System	Lamps	Sleeves	Controller
Aqua Flo Gen 4-8R1	RL-420 #40040096	RQ-420 #40040042	RC-B4.01 #40040112
Aqua Flo Gen 4-8R2	RL-330HO #40040019	RQ-420 #40040042	RC-B4.01 #40040112
Aqua Flo Gen 4-13R2	RL-420HO #40040020	RQ-420 #40040042	RC-B4.01 #40040112
Aqua Flo Gen 4-13R22	RL-420HO #40040020	RQ-420 #40040042	RC-B4.01 #40040112

Aqua Flo Gen 5 UV/Filter Rack System

A Combination Water System For Your Entire Home or Cottage

Combining ultraviolet disinfection (UV) with whole-house filtration provides your home or cottage with clean, great-tasting water that you can rely on. UV is proven to control microbiological (bacteria & virus) issues in water including ***E.coli***, ***Cryptosporidium***, and ***Giardia Lamblia*** without the use of chemicals. Combining UV disinfection with whole-house sediment and/or carbon pre-treatment filters improves UV performance and the taste, smell and clarity of your water.

Features:

- Four models provide a range of flow rate and filter combination options suitable for your specific needs
- Models for 8 & 13 gpm flow rates
- All systems include 5 micron sediment removal pretreatment required for proper UV performance
- Optional 'high-flow' carbon filters to treat bad tastes and odors
- Pressure relief, high-flow polypropylene filter housings
- Colour user interface with full diagnostics and warnings including QR codes
- "Future-proof" expandability port for future upgrades and options
- Designed & manufactured to ASME pressure vessel standards
- Axial flow, 316L stainless steel polished reactors designed & manufactured to ASME pressure vessel standards
- Flow rates stated at 95% UVT at a dose of 30mJ/cm²
- User friendly bayonet style lamp connector (Quick ¼ turn removal. No extra tools required.)
- Reliable, industry proven low pressure (LP) coated UV lamps with ceramic bases for durability and a 9000 hour life (1 year)
- Constant current electronic controller in a splash-proof case



GEN5-8R1



GEN5-8R12



GENH5-13R2



GENH5-13R22

AQUA FLO®

Guidelines for Use

Parameter	Level
Hardness	< 7 gpg (120 mg/L)
Iron (Fe)	< 0.3ppm (mg/L)
Manganese (Mn)	< 0.05ppm (mg/L)
Tannins	< 0.1ppm (mg/L)
Turbidity	< 1 NTU
Transmittance (UVT)	> 75%

AQUA FLO GEN-5, UV/Filter Rack System

MODEL	GEN5-8R1 40030050N	GEN5-8R12 40030051N	GENH5-13R2 40030052N	GENH5-13R22 40030053N
Flow Rate (@ 30 ml/cm ² @ 95% UVT)	8.0 GPM	8.0 GPM	13.0 GPM ²	13 GPM ²
	30 lpm	30 lpm	49.2 lpm ²	49.2 lpm ²
	1.8 m ³ /hr.	1.8 m ³ /hr.	2.95 m ³ /hr. ²	2.95 m ³ /hr. ²
1st Filter Housing	10" 5 Micron Sediment 26235	10" 5 Micron Sediment 26235	20" 5 Micron Sediment 26239	20" 5 Micron Sediment 26239
2nd Filter Housing	N/A	20" High Capacity Carbon 26256	N/A	20" High Capacity Carbon 26256
Port Size	1" MNPT			
Electrical	90-265V/50-60Hz.			
Plug Type	North American, NEMA 5-15, 3-wire for all 110V			
Lamp Watts	20 (Standard-Output Lamp)		45 (High-Output Lamp)	
Power (watts)	23	23	57	57
Max Current (amps)	1			
Chamber Dimensions	3.5 x 20.0" (8.9 x 50.8 cm)			
Chamber Material	Polished 316 Stainless Steel, A249 Pressure Rated Tubing			
Controller Dimensions	6.8 x 3.6 x 3" (171.5 x 92.1 x 76.2 mm)		8.6 x 4.2 x 3.5" (21.7 x 10.8 x 8.9 cm)	
Operating Pressure	0.7-10.3 bar (10-150 psi)			
Operating Water Temperature	2-40° C (36-104° F)			
UV Monitor	Optional (Requires additional UV Sensor Module)			
Solenoid Output	Yes, but requires optional solenoid module			
Dry Contacts	Yes, but requires optional remote alarm module			
Lamp Change Reminder (Audible & Visual)	Yes			
Lamp-Out Indicator (Audible & Visual)	Yes			
Shipping Weight	18.5 Lbs (8.4 Kg)	31.5 Lbs (14.3 Kg)	31.5 Lbs (14.3 Kg)	34.2 Lbs (15.5 Kg)
Note: 1. based on flow velocity of 8.2 ft/sec (2.5 m/sec.), flow rate limited to 13.6 gpm (50 lpm) (3.1 m ³ /hr.) for 3/4" port 2. based on flow velocity of 8.2 ft/sec (2.5 m/sec.), flow rate limited to 22.1 gpm (84 lpm) (5.0 m ³ /hr.) for 1" port				

Sample Screens



NSF Certified Models Available. Contact Customer Service For Details.

Options



UV Sensor Module

Allows the 254nm UV wavelength to be measured and displayed via the GEN-5 UV controller. The sensor plugs directly into the controller and is mounted in the sensor port located on all GEN-5 units.



Solenoid Module

Used to power a remote normally closed solenoid valve (not included). Solenoid valve will close on lamp failure or when low UV conditions are detected by the sensor. Available in 110V MODSOL1 (Item # 40040006)



4-20mA Module Used for signal transfer to a remote device such as a data logger or computer.



Remote Alarm (Dry Contact) Module Used for signal transfer to a remote alarm or dry contacts.

REPLACEMENT PARTS

System	Lamps	Sleeves	Controller
Aqua Flo Gen 5-8R1	RL-420	RQ-420	RC-B56.01
	#40040096	#40040042	#40040066
Aqua Flo Gen 5-8R2	RL-330HO	RQ-420	RC-B56.01
	#40040019	#40040042	#40040066
Aqua Flo Gen 5-13R2	RL-420HO	RQ-420	RC-B56.01
	#40040020	#40040042	#40040066
Aqua Flo Gen 5-13R22	RL-420HO	RQ-420	RC-B56.01
	#40040020	#40040042	#40040066

Aqua Flo Ultraviolet Disinfection Systems

UVB Series™

AQUA FLO®

Aqua Flo Product's patented UVB Series is designed to provide disinfected water at a flow rate of 2 gallons per minute. In addition to disinfection, water is filtered through our 0.5 micron Extended Pass Carbon Block (EPCB) filter. Our double and triple models provide you with additional filtration with sediment and activated carbon filters.

This compact All-in-One system installs with ease and can be used anywhere that clean, clear, good tasting disinfected water is needed. It is ideal for point-of-use applications like under the kitchen sink, office water coolers, water vending machines, boats, recreational vehicles, etc.

Features:

- ➔ Electronic lamp indicator (LED)
- ➔ Standard voltage 115V

Options:

- ➔ 220V/50Hz (2-Prong Euro plug)
- ➔ 12V DC
- ➔ Lamp Out Circuit (LOC) - (normally open) Safety monitor for alarm
- ➔ Lamp Out Circuit (LOC) - (normally closed) Safety monitor for solenoid shut off
- ➔ Three year warranty except on electrical components which are covered for a period of one year.

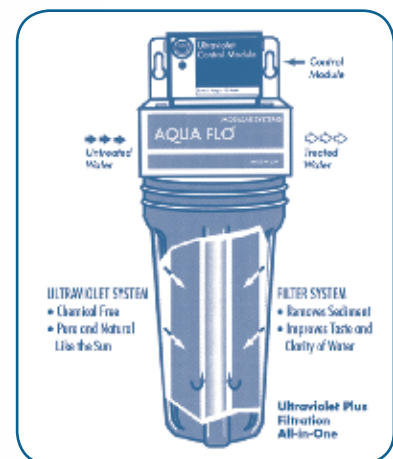

Specifications & Performance UVB Series

Part #	Model Description	# of Sumps	Sump Type	Sump 1	Sump 2	Sump 3	Lamp #	Power Used	Flow Rates ¹ GPM (L/min)	Dimensions HxWxD In. (cm)	Shipping Weight LBS. (kg)	Inlet/ Outlet Size
15610111	UVB1-EPCB	1	#10	EPCB Carbon/UV	None	None	# 11	14 Watts	2 (7.6)	15 x 5.5 x 5.5 (38.1 x 14 x 14)	10.0 (4.5)	3/8" NPT
15610411	UVB1-EPCB Normally Closed	1	#10	EPCB Carbon/UV	None	None	# 11	14 Watts	2 (7.6)	15 x 5.5 x 5.5 (38.1 x 14 x 14)	10.0 (4.5)	3/8" NPT
15610511	UVB1-EPCB Normally Open	1	#10	EPCB Carbon/UV	None	None	# 11	14 Watts	2 (7.6)	15 x 5.5 x 5.5 (38.1 x 14 x 14)	10.0 (4.5)	3/8" NPT
15620121	UVB2-EPCB/SD	2	#10	5 Micron Sed Filter	EPCB Carbon/ UV	None	# 11	14 Watts	2 (7.6)	15 x 11 x 5.5 (38.1 x 27.9 x 14)	15.0 (6.8)	3/8" NPT
15630131	UVB3- EPCB/GC/SD	3	#10	5 Micron Sed Filter	Granular Carbon Filter	EPCB Carbon/ UV	# 11	14 Watts	2 (7.6)	15 x 11 x 5.5 (38.1 x 27.9 x 14)	24.0 (10.9)	3/8" NPT

Note: (1) All flow rates shown will provide a UV dose of no less than 16,000 mW-s/cm² or greater.

Aqua Flo Ultraviolet Disinfection Systems

UV20 Series™

The Aqua Flo Product's UV20 Series is designed to provide disinfected water at a flow rate of 8 - 10 gallons per minute. This system is ideal for whole house water treatment. In addition to disinfection, the double and triple models provide filtration for the removal of sediment and chemical contaminants.

This ultraviolet water treatment system makes a perfect companion to water softeners, distillers, reverse osmosis and ozone systems. The UV20 Series has proven to be Aqua Flo Product's most popular product line and has created an industry standard in whole house disinfection.

Features:

- ➔ Electronic lamp indicator (LED)
- ➔ Standard voltage 115V

Options:

- ➔ 220V/50Hz (2-Prong Euro plug)
- ➔ 12V DC
- ➔ Lamp Out Circuit (LOC) - (normally open) Safety monitor for alarm
- ➔ Lamp Out Circuit (LOC) - (normally closed) Safety monitor for solenoid shut off
- ➔ Three year warranty except on electrical components which are covered for a period of one year.



AQUA FLO®

Specifications & Performance UV20 Series

Part #	Model Description	# of Sumps	Sump Type	Sump 1	Sump 2	Sump 3	Lamp #	Power Used	Flow Rates ¹ GPM (L/min)	Dimensions HxWxD In. (cm)	Shipping Weight LBS. (kg)	Inlet/Outlet Size
15710100	UV20-1	1	#20	UV	None	None	# 20	22 Watts	10 (38)	25 x 5.5 x 5.5 (63.5 x 14 x 14)	16.0 (7.3)	3/4" NPT
15710400	UV20-1 Normally Closed	1	#20	UV	None	None	# 20	22 Watts	10 (38)	25 x 5.5 x 5.5 (63.5 x 14 x 14)	16.0 (7.3)	3/4" NPT
15710500	UV20-1 Normally Open	1	#20	UV	None	None	# 20	22 Watts	10 (38)	25 x 5.5 x 5.5 (63.5 x 14 x 14)	16.0 (7.3)	3/4" NPT
15720121	UV20-2 SD	2	#20	5 Micron Sed Filter	UV	None	# 20	22 Watts	10 (38)	25 x 11 x 5.5 (63.5 x 27.9 x 14)	23.0 (10.4)	3/4" NPT
15720421	UV20-2 SD Normally Closed	2	#20	5 Micron Sed Filter	UV	None	# 20	22 Watts	10 (38)	25 x 11 x 5.5 (63.5 x 27.9 x 14)	23.0 (10.4)	3/4" NPT
15720521	UV20-2 SD Normally Open	2	#20	5 Micron Sed Filter	UV	None	# 20	22 Watts	10 (38)	25 x 11 x 5.5 (63.5 x 27.9 x 14)	23.0 (10.4)	3/4" NPT
15730131	UV20-3 SD/CB	3	#20	5 Micron Sed Filter	10 Micron Carbon Block	UV	# 20	22 Watts	8 (30)	25 x 16 x 5.5 (63.5 x 40 x 14)	33.0 (15.0)	3/4" NPT
15730431	UV20-3 SD/CB Normally Closed	3	#20	5 Micron Sed Filter	10 Micron Carbon Block	UV	# 20	22 Watts	8 (30)	25 x 16 x 5.5 (63.5 x 40 x 14)	33.0 (15.0)	3/4" NPT
15730531	UV20-3 SD/CB Normally Open	3	#20	5 Micron Sed Filter	10 Micron Carbon Block	UV	# 20	22 Watts	8 (30)	25 x 16 x 5.5 (63.5 x 40 x 14)	33.0 (15.0)	3/4" NPT

Note: (1) All flow rates shown will provide a UV dose of no less than 16,000 mW-s/cm² or greater.

Aqua Flo Ultraviolet Disinfection Systems

UV BigBoy™ Series

The UV BigBoy Series is the most versatile commercial ultraviolet disinfection system on the market today. This 15 to 60 GPM series is manufactured with versatility in mind, and is virtually unlimited in the possible filter configurations and manifold sequences. The series is designed with the same traditional style that PURA has made an industry standard - worldwide.

One advantage of the UV BigBoy Series is the convenient manifold mounting rack. The rack can be used to configure up to four UV chambers in parallel or in series. This allows the user to achieve either a higher UV dosage or higher flow rate (up to 60 GPM).

This mounting rack configuration provides easy access for cleaning and maintenance to the individual units without the need to shut down the entire water distribution line. The standard LED lamp monitor provides a visual verification the lamp is in operation.

The UV BigBoy Series, with its capacity, versatility and cost, to be the world's most flexible, complete water disinfection system in its class.



Features:

- ➔ Electronic lamp indicator (LED)
- ➔ Standard voltage 115V

Options:

- ➔ 220V/50Hz (2-Prong Euro plug)
- ➔ 12V DC
- ➔ Lamp Out Circuit (LOC) - (normally open) Safety monitor for alarm
- ➔ Lamp Out Circuit (LOC) - (normally closed) Safety monitor for solenoid shut off
- ➔ Three year warranty except on electrical components which are covered for a period of one year.

AQUA FLO®

Specifications & Performance UV BigBoy Series

Part #	Model Description	# of Sumps	Sump Type	Sump 1	Sump 2	Sump 3	Lamp #	Power Used	Flow Rates ¹ GPM (L/min)	Dimensions HxWxD In. (cm)	Shipping Weight LBS. (kg)	Inlet/Outlet Size
15810100	UVBB-1	1	#20BB	UV	None	None	#20	22 Watts	15 (57)	28 x 7.5 x 9.0 (71.1 x 19 x 22.9)	18.0 (8.2)	1-1/2" NPT
15810400	UVBB-1 Normally Closed	1	#20BB	UV	None	None	#20	22 Watts	15 (57)	28 x 7.5 x 9.0 (71.1 x 19 x 22.9)	18.0 (8.2)	1-1/2" NPT
15810500	UVBB-1 Normally Open	1	#20BB	UV	None	None	#20	22 Watts	15 (57)	28 x 7.5 x 9.0 (71.1 x 19 x 22.9)	18.0 (8.2)	1-1/2" NPT
15820121	UVBB-2	2	#20BB	5 Micron Sed Filter	UV	None	#20	22 Watts	15 (57)	28 x 15 x 9.0 (71.1 x 38.1 x 22.9)	35.0 (15.9)	1-1/2" NPT
15820421	UVBB-2 Normally Closed	2	#20BB	5 Micron Sed Filter	UV	None	#20	22 Watts	15 (57)	28 x 15 x 9.0 (71.1 x 38.1 x 22.9)	35.0 (15.9)	1-1/2" NPT
15820521	UVBB-2 Normally Open	2	#20BB	5 Micron Sed Filter	UV	None	#20	22 Watts	15 (57)	28 x 15 x 9.0 (71.1 x 38.1 x 22.9)	35.0 (15.9)	1-1/2" NPT
15830131	UVBB-3	3	#20BB	5 Micron Sed Filter	10 Micron Carbon Block	UV	#20	22 Watts	15 (57)	28 x 23 x 9.0 (71.1 x 58.4 x 22.9)	54.0 (24.5)	1-1/2" NPT
15830431	UVBB-3 Normally Closed	3	#20BB	5 Micron Sed Filter	10 Micron Carbon Block	UV	#20	22 Watts	15 (57)	28 x 23 x 9.0 (71.1 x 58.4 x 22.9)	54.0 (24.5)	1-1/2" NPT
15830531	UVBB-3 Normally Open	3	#20BB	5 Micron Sed Filter	10 Micron Carbon Block	UV	#20	22 Watts	15 (57)	28 x 23 x 9.0 (71.1 x 58.4 x 22.9)	54.0 (24.5)	1-1/2" NPT

Model Description	# of Sumps	Sump Type	Sump 1	Sump 2	Sump 3	Sump 4	Lamp #	Power Used	Flow Rates ¹ GPM (L/min)	Dimensions HxWxD In. (cm)	Shipping Weight LBS. (kg)	Inlet/Outlet Size
UVBB-R1	4	#20BB	empty ⁽²⁾	empty ⁽²⁾	empty ⁽²⁾	UV	#20	22 Watts	15 (57)	45 x 34 x 18 (114 x 86 x 45)	65.0 (29.5)	1-1/2"
UVBB-R2	4	#20BB	empty ⁽²⁾	empty ⁽²⁾	UV	UV	#20	44 Watts	30 (114)	45 x 34 x 18 (114 x 86 x 45)	75.0 (34.0)	1-1/2"
UVBB-R4	4	#20BB	UV	UV	UV	UV	#20	88 Watts	60 (227)	45 x 34 x 18 (114 x 86 x 45)	91.0 (41.3)	1-1/2"

Aqua Flo Ultraviolet Disinfection Systems

UV1-EPCB Series™

Aqua Flo Product's UV1-EPCB Series is a bright example of Aqua Flo Product's patented All-In-One concept. This product combines both ultraviolet disinfection with carbon filtration all in a very attractive and compact system.

The UV-1 Series is rated for 1 gallon per minute and uses either a 0.5 micron (EPCB) carbon block filter or a 10 micron (EPCB 10) carbon block filter. This easy to install system can be used as a stand alone or in conjunction with other water treatment products.

Features:

- ➔ Compact Size
- ➔ Standard voltage 115V

Options:

- ➔ 220V/50Hz (2-Prong Euro plug)
- ➔ 12V DC



Specifications & Performance UV1-EPCB Series

Part #	Model Description	# of Sumps	Sump Type	Sump Content	Lamp #	Power Used	Flow Rates ¹ GPM (L/min)	Dimensions HxWxD In. (cm)	Shipping Weight LBS. (kg)	Inlet/Outlet Size
15910111	UV1-EPCB	1	#10SL	EPCB Carbon/UV	#10	10 Watts	1 (3.8)	13.5 x 5.0 x 5.0 (34.3 x 12.7 x 12.7)	7.0 (3.2)	1/2" NPT

Notes: EPCB refers to Extended Pass Carbon Block filter
 (1) All flow rates shown will provide a UV dose of no less than 16,000 mW-s/cm² or greater.

UV ADDON Series™

Aqua Flo Product's UV ADDON Series is designed to be an easy addition to water treatment systems that require ultraviolet disinfection (RO systems, holding tanks, water dispensers, recirculating systems and more). The ADDON systems are available with a 1 GPM or 3 GPM flow rate. They are constructed using a 304 grade stainless steel body with a molded head that includes 3/8" quick connect fittings on the inlet/outlet. This versatile system also includes a heavy duty mounting bracket, but will also fit standard 2" RO mounting clips. The UV ADDON Series can be used almost anywhere and is equipped with a unique power supply that makes installation simple, space requirements minimal and lamp changes easy.

Features:

- ➔ 3/8" quick connect fittings
- ➔ Standard voltage 115V

Options:

- ➔ 220V/50Hz (2-Prong Euro plug)
- ➔ 12V DC



Specifications & Performance UV ADDON Series

Part #	Model Description	# of Sumps	Sump Type	Sump Content	Lamp #	Power Used	Flow Rates ¹ GPM (L/min)	Dimensions HxWxD In. (cm)	Shipping Weight LBS. (kg)	Inlet/Outlet Size
15520100	UV ADDON-1	1	304 SS	UV	#10	10 Watts	1 (3.8)	12 x 4 x 3.5 (30.5 x 10.2 x 8.9)	5.0 (2.3)	3/8" QC
15540100	UV ADDON-3	1	304 SS	UV	#20	22 Watts	3 (11.4)	22.5 x 4 x 3.5 (57.2 x 10.2 x 8.9)	7.0 (3.2)	3/8" QC

Notes: (1) All flow rates shown will provide a UV dose of no less than 16,000 mW-s/cm² or greater.

AQUA FLO®



AQUA FLO®

Aqua Flo
Point-of-Use
Filtration Products



Aqua Flo Filtration Products

Your Water Quality is a Growing Concern

Aging infrastructure and increasing groundwater contamination is a growing reality and concern. The ingestion and inhalation of water disinfection products, such as chlorine, is also undesirable and unnecessary from both an aesthetic and physical standpoint.

Finding The Right Solution

Improving your water quality is easy and economical. While bottled water remains a popular option for drinking water, it is an expensive, less convenient alternative that creates waste and is hard on the environment.

Aqua Flo™ Water Filtration Products provide you with a wide range of solutions for fresh, clean water. Not only do you get great-tasting water for drinking and cooking, you also get clear, odor free water for washing and utility use. No more carrying or storing heavy bottles either!

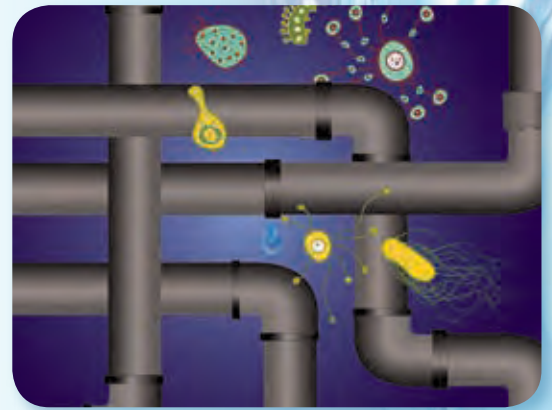

Water travels through miles of pipes before reaching your home. Chlorine is commonly used to kill bacteria along the way. Once at your tap, it is desirable to reduce chlorine.

Aqua Flo Filter Cartridges are available to solve a wide variety of water problems:

- ➔ Remove dirt, silt, clay and other sediments
- ➔ Remove iron to prevent staining
- ➔ Minimize unpleasant odors, including chlorine

Understanding Your Aqua Flo Filtration System

Aqua Flo Filtration Systems consist of a Filter Housing that connects to your plumbing system and disposable Filter Cartridge that performs the work. Depending on your needs, systems can consist of a single or series of Housings installed either under a specific sink (Point-of-Use) or where the water main enters the home (Point-of-Entry). Filter Cartridges are easily replaced periodically, typically on an annual or semi-annual basis, depending on your incoming water quality.

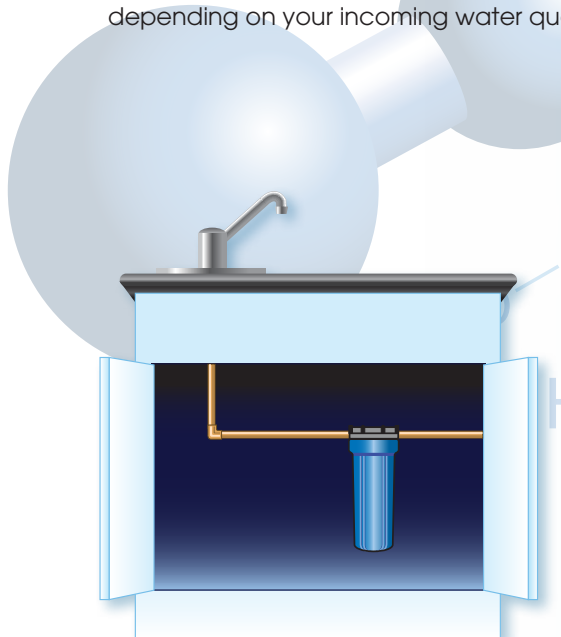

Point of Use

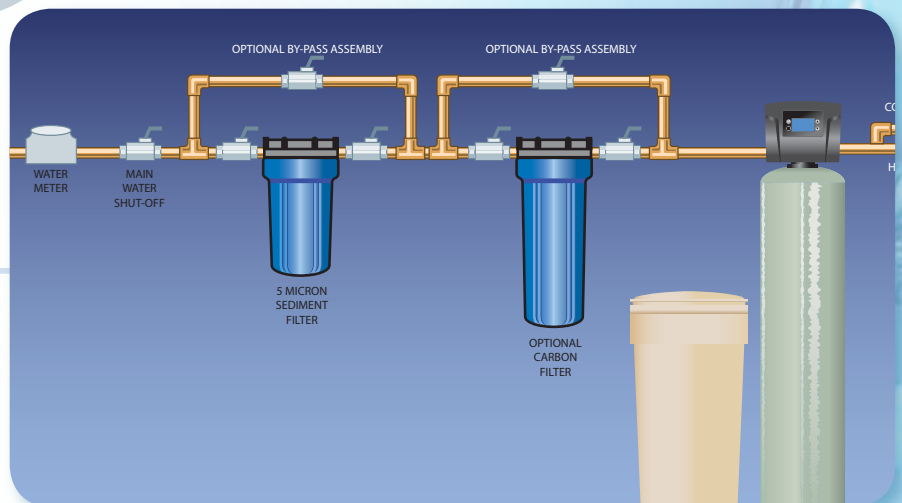

Point of Entry

Aqua Flo Filtration Products

All Aqua Flo Filtration products provide durable, high-quality reliable performance.

The **Aqua Flo Platinum line** features top-of-the-line performance plus **3rd party certification** which is sometimes required by local plumbing codes.

AQUA FLO[®]

PLATINUM



Visit www.nsf.org for specific details on certification



Visit www.iapmo.org for specific details on certification



The **Aqua Flo Value line** also offers great performance and durability at a more economical price point.

AQUA FLO[®]



Aqua Flo Filtration Products

Filter Housings

Filter Housings come in different sizes, colors, materials of construction and offer different features.

Here is a quick breakdown:

- ➔ Size – Required flow rates and installation space will determine the size of the housing. Housings typically come in four sizes: 2.5" x 10", 2.5" x 20", 4.5" x 10", 4.5" x 20"
- ➔ Color – Transparent or Opaque (Blue). Transparent housings allow for visual inspection of the cartridges but are less durable and not suitable for outdoor applications.
- ➔ Material of Construction - Plastic is standard for most applications. Stainless steel is used for higher temperature applications.

Features – Some housings provide additional unique features:

- ➔ Valve-in-Head – allows you to bypass or shut off the water during cartridge replacement.
- ➔ Pressure Relief Button – relieves pressure from the housing prior to changing cartridge
- ➔ Stainless Steel Threads – reduces possibility of cross threading and allows for tighter pipe fit
- ➔ Double O-Ring – ensures added seal insurance protecting from leaks



Double O-Ring Seal
(Aqua Flo Platinum Only)



Pressure Relief Button



Valve-in-Head

Filter Housing Kits

All Aqua Flo® Point-of-Use Water Filter Housings are easy to install and come with a mounting bracket and hardware plus sump wrench for easy sump removal. Filter cartridges are sold separately.



Sump Wrench



Mounting Bracket and Hardware

WARNING:

Do not use on drinking water supplies, which are microbiologically unsafe or of unknown quality without first adequately disinfecting the water. Protect against freezing to prevent cracking of the filter and water leakage.

NOTE:

All dimensions and micron ratings are nominal. The manufacturer reserves the right to make product improvements which may deviate from the specifications and descriptions stated herein, without obligation to change previously manufactured products or to note the change.

We recommended replacing the clear sump every 5 years. Do not subject to freezing temperatures.

Aqua Flo Filtration Products

Filter Housings



P-H-PR-20BV



P-H-PR-20



P-H-PR-10



P-H-PR-10BV



P-SL-10-1/2-NPR

Aqua Flo Platinum™ Housings

Item #	Model Description	Features	Filter Size (In)	Inlet/Outlet Size NPT (In)	Color	Flow Rate (USGPM)	Dimensions A X B (In)	Weight (Lbs)	Certification
36051	HOUSING, P-H-PR-10-34	Pressure Relief, Double O-Ring	2.5" x 10"	3/4"	Blue	4	5 X 12	4	NSF 42
36053	HOUSING, P-H-PR-10BV-1	Pressure Relief, Double O-Ring	4.5" x 10"	1"	Blue	15	7 X 14	6	NSF 42
36112	HOUSING, P-H-PR-20BV-1	Pressure Relief, Double O-Ring	4.5" X 20"	1"	Blue	20	7 X 24	8	NSF 42
36237	HOUSING, P-SL-10-1/2-NPR	NA	2.5" x 10"	1/2"	Blue	4	4 X 12	4	NSF 42
36273	HOUSING, P-H-PR-20-34	Pressure Relief, Double O-Ring	2.5" x 10"	3/4"	Blue	4	5 X 23	7	NSF 42

*NSF-42 for Material Safety and Structural Integrity Only

Aqua Flo™ Housings

Item #	Model Description	Features	Filter Size (In)	Inlet/Outlet Size NPT (In)	Color	Flow Rate (USGPM)	Dimensions A X B (In)	Weight (Lbs)	Certification
26065	HOUSING, WVIH34SS	Valve-in-Head, SS Thread	2.5" x 10"	3/4"	Clear	4	5" x 13.5"	4	No
26066	HOUSING, WCT34SS	Pressure Relief, SS Threads	2.5" x 10"	3/4"	Clear	4	5.25" x 12.25"	4	No
26258	HOUSING, H-PR-10BV-1	Pressure Relief	4.5" x 10"	1"	Blue	15	7.25" x 14"	6	No
26259	HOUSING, H-PR-20BV-1	Pressure Relief	4.5" x 20"	1"	Blue	20	7.25" x 24"	8	No
26261	HOUSING, H-PR-20BV-34	Pressure Relief	4.5" x 20"	3/4"	Blue	20	7.25" x 24"	8	No
26262	HOUSING, H-PR-10BV-34	Pressure Relief	4.5" x 10"	3/4"	Blue	15	7.25" x 14"	6	No
26263	HOUSING, H-PR-20BV-15	Pressure Relief	4.5" x 20"	1.5"	Blue	20	7.25" x 24"	7	No
26264	HOUSING, H-PR-10-34	Pressure Relief	2.5" x 10"	3/4"	Blue	4	5.25" x 12.25"	4	No
26265	HOUSING, H-PR-20-34	Pressure Relief	2.5" x 20"	3/4"	Blue	4	5.25" x 22.5"	7	No
65020006	HOUSING, APC34	Pressure Relief	2.5" x 10"	3/4"	Clear	4	5.25" x 12.25"	3	No
65020007	HOUSING, VIH34	Valve-in-Head	2.5" x 10"	3/4"	Clear	4	5" x 13.5"	4	No

Specifications:

- ➔ Max. Water Temperature: 30°C (100°F)
- ➔ Min. Water Temperature: 2°C (35°F)
- ➔ Max. Water Pressure; 100 psi (689 kPa)
- ➔ Materials of Construction: Reinforced Polypropylene (cap and blue sump) & Styrene-Acrylonitrile (clear sump)
- ➔ Housing O-Ring: EPDM
- ➔ Pressure Relief Button: Nylon
- ➔ Limited One Year Warranty



Aqua Flo Filtration Products

Cartridge Selection Guide

Model #	Scale and Rust Particles	Coarse Sand	Sand/ Dirt/ Silt	Fine Dirt/ Silt/ Sand	Extra Fine Dirt/Silt/ Sand	Bad Taste & Odor	Aesthetic Chlorine: Taste & Odor
Pleated Polyester Cartridge (PPC) Filter							
PPC-1-10, PPC-5-20BV, P-PPC-5-BV	✓	✓	✓	✓	✓		
PPC-20-10BV	✓	✓	✓				
PPC-20-20BV	✓	✓	✓				
Dual Gradient (DG) Density Cartridge Filter**							
DG-25-1-10BV, DG-50-5-20BV, P-DG-50-5-20BV	✓	✓	✓	✓	✓		
DG-75-25-10BV, DG-75-25-20BV	✓	✓	✓				
Carbon Block (CB) Cartridge Filter (†)							
P-CCB-1-10, P-CB-10-20BV, CCB-1-10, CB-10-20BV						✓	✓
Pleated Polyester Reusable (PR) Cartridge Filter							
PR-30-10BV, P-PR-30-10BV, P-PR-30-20BV, PR-30-20BV	✓	✓					
Radial Flow (RF) Granular Activated Carbon Cartridge Filter							
RF-20, RF-20BV, P-RF-20BV						✓	✓
Impregnated Carbon Cellulose (ICC) Dual Purpose Filter (†) (‡)							
ICC-5-10, P-CC-5-10	✓	✓	✓	✓	✓	✓	✓
ICC-20-20BV	✓	✓	✓			✓	✓
Impregnated Carbon Polyester (ICP) Dual Purpose Filter (‡)							
ICP-10-10	✓	✓	✓	✓	✓	✓	✓
ICP-10-20BV	✓	✓	✓			✓	✓
Pleated Cellulose (PC) Cartridge Filter*							
PC-20-10, P-PC-20-20BV, PC-20-20BV	✓	✓	✓				
Granular Activated Carbon (GAC) Cartridge Filter (††)							
CGACC-10, CGAC-20BV						✓	✓
Spun Poly Bonded (SPB) Cartridge Filter							
SPB-1-10, SPB-5-20, P-SPB-5-20	✓	✓	✓	✓	✓		
Polypropylene Melt Blown (PPMB) Filter Cartridge							
PPMB-5-10, PPMB-5-20BV	✓	✓	✓	✓	✓		
PPMB-10-10, PPMB-10-20BV	✓	✓	✓	✓			
PPMB-25-10	✓	✓	✓				
PPMB-50-10	✓	✓					
PPMB-25-20	✓	✓	✓				
PPMB-50-20	✓	✓					
PPMB-20-40	✓	✓	✓				
PPMB-20-10BV	✓	✓	✓				
PPMB-20-20BV	✓	✓	✓				
String Wound (SW) Cartridge Filter							
SW-5-10, P-SW-5-10, SW-5-20	✓	✓	✓	✓	✓		
SW-30-10, P-SW-30-10, SW-30-10	✓	✓					

Filter Cartridges

There is an overwhelming selection of cartridges to choose from. We offer a range of popular cartridges to cover most water quality needs. Your Professional Water Specialist can help determine the correct filtration products for your needs.

What is a Micron Rating?

A micron rating is also common for most cartridges. One micron is equivalent to 0.000039 inches (the diameter of a human hair is 50 to 70 microns). Choosing the right micron rating is a balance between performance and cartridge life. If you chose a smaller micron rating and the cartridge is loading up too fast then a higher micron rated cartridge may provide a better balance.

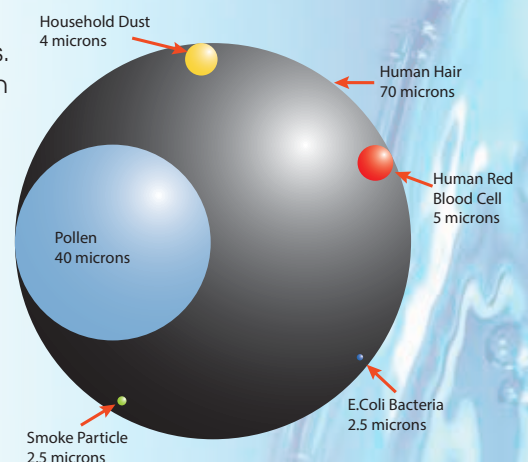

Aqua Flo Platinum Filters



Carbon Block (CB) Cartridge Filter



The CB cartridge filter is suitable for high capacity chlorine and bad taste and odor reduction from drinking water. These filters are also used for sediment filtration, making them a great choice for pre-filtering water for reverse osmosis applications. They make an ideal choice for a wide range of residential, food service, commercial and industrial applications.

Item #	Model #	Maximum Size	Micron	Capacity (Gallons)	Flow Rate (gpm)
36002	P-CB-0.5-10	2.5" X 10"	.5	10000 @ 1.0	1.0 gpm
36008	P-CB-0.5-20BV	4.5" X 20"	.5	40000 @ 6.0	6.0 gpm
36012	P-CB-10-10	2.5" X 10"	10	8000 @ 1.0	1.0 gpm
36015	P-CB-10-10BV	4.5" X 10"	10	16000 @ 3.0	3.0 gpm
36017	P-CB-10-20	2.5" X 20"	10	16000 @ 2.0	2.0 gpm
36020	P-CB-10-20BV	4.5" X 20"	10	32000 @ 6.0	6.0 gpm
36023	P-CB-5-10	2.5" X 10"	5	8000 @ 1.0	1.0 gpm
36025	P-CB-5-10BV	4.5" X 10"	5	16000 @ 3.0	3.0 gpm
36027	P-CB-5-20	2.5" X 20"	5	16000 @ 2.0	2.0 gpm
36029	P-CB-5-20BV	4.5" X 20"	5	32000 @ 6.0	6.0 gpm
36032	P-CCB-1-10	2.5" X 10"	1	8000 @ 1.0	1.0 gpm
36034	P-CCB-5-10	2.5" X 10"	5	8000 @ 1.0	1.0 gpm
36073	P-LR-0.5-10	2.5" X 10"	.5	6000 @ 1	1.0 gpm

Features:

- High Dirt-Holding Tolerance
Maximizes Utilization of the Carbon Block
- High porosity maximizes utilization of the carbon block



IAPMO R & T Certified against NSF 42 for Material Safety Only

Dual Gradient (DG) Density Cartridge Filters



DG cartridge filters are made from 100% polypropylene. The progressively loose structure from inside to outside enhance cartridge performance in reduction of dirt, dust and other particles. The two separate gradient layers of the filter enhances the performance such that it achieves a much higher dirt-loading capacity compared to similar size sediment cartridge filters including spun and string-wound. They make an ideal sediment reduction choice for a wide range of residential, food service, commercial and industrial applications.

Item #	Model #	Maximum Size	Micron	Flow Rate (gpm)
36041	P-DG-25-1-20BBV	4.5" x 20"	25.0/1	20.0
36043	P-DG-50-5-10BV	4.5" X 10"	50/5	10.0
36045	P-DG-50-5-20BV	4.5" X 20"	50/5	20.0
36047	P-DG-75-25-10BV	4.5" X 10"	75/25	10.0
36049	P-DG-75-25-20BV	4.5" X 20"	75/75	20.0

Features:

- No Fiber release and media migration
- Designed for purity, bacteria and chemical resistance
- Two Separate Gradient density layers enhance cartridge performance
- Three times the dirt-holding capacity than other traditional sediment filters



IAPMO R & T Certified against NSF 42 for Material Safety Only

*Impregnated Carbon Cellulose (ICC) Dual Purpose Filter

The ICC cartridge filter has a dual benefit for sediment filtration and reduction of chlorine and bad taste and odor from drinking water. These carbon wrap sediment cartridges consist of polypropylene melt blown core with carbon impregnated outer layer wrap. It is an economical solution for general water filtration requirements. This filter has high dirt-loading capacity and is recommended for chlorinated water supplies. These dual-purpose cartridges are well suited for residential applications, and are great polishing filters for closed loop water stream systems. The netting and reinforced support provide strength to the filter.



Part #	Model #	Maximum Size	Micron	Capacity (Gallons)	Flow Rate (gpm)
36151	P-ICC-5-5	2.5" X 5"	5	250 @ 0.5	0.5
36062	P-ICC-5-10	2.5" X 10"	5	100 @ 1.0	2.0
36064	P-ICC-5-20	2.5"X20"	5	100 @ 1.0	2.0

Item 36151 & 36064 are NSF / ANSI 42 for Material Safety Only.
Item 36062 is IAPMO R & T Certified to NSF / ANSI 42 Standards.

Features:

- Provides sediment filtration as well as taste/odor /chlorine reduction
- High dirt loading capacity
- External netting for additional strength

Aqua Flo Platinum Filters

Impregnated Carbon Polyester (ICP) Dual Purpose Filter

The ICP cartridge filter has a dual benefit for sediment filtration and reduction of chlorine and bad taste and odor from drinking water. These carbon wrap sediment cartridges consist of polypropylene melt blown cores with carbon impregnated outer layer wraps. It is an economical solution for general water filtration requirements. This filter is recommended for chlorinated water supplies. These dual-purpose cartridges are well suited for residential applications and are great polishing filters for closed-loop water stream systems.

Item #	Model #	Maximum Size	Micron	Capacity (Gallons)	Flow Rate (gpm)
36066	P-ICP-10-10BV	4.5" X 10"	10	100 @ 1	2 gpm
36182	P-ICP-10-20	2.5" X 20"	10	1000 @ 2	2 gpm

Features:

- Provides sediment filtration as well as taste/odor /chlorine reduction
- High dirt loading capacity
- External netting for additional strength

Material Information

End Cap Material - Polypropylene
Core - Polypropylene
Gasket - Silicon/PVC
Filter Media - Carbon Impregnated Polyester
Netting - Polypropylene

Pleated Polyester Reusable (PR) Cartridge Filter



PR cartridge filters are made from reusable polyester fibers which are pleated to maximize dirt holding capacity. These cartridge filters are multipurpose.

Item #	Model #	Maximum Size	Micron	Capacity (Gallons)	Flow Rate (gpm)
36076	P-PR-30-10	2.5" X 10"	30.0	9600	10.0
36078	P-PR-30-10BV	4.5" X 10"	30.0	24000	10.0
36083	P-PR-30-20BV	4.5" X 20"	30.0	48000	10.0
36085	P-PR-50-10	2.5" X 10"	50.0	9600	10.0
36087	P-PR-50-10BV	4.5" X 10"	50.0	24000	10.0



NSF/ANSI 42 for Material Safety Only. Visit www.nsf.org for specific details on certification

Features:

- Pleated design maximizes dirt-holding capacity
- Durable, versatile and reusable
- Polyester media is bacteria and chemical resistant
- Nominal 30-micron rating and nominal 50-micron rating



Radial Flow (RF) Granular Activated Carbon Cartridge Filters

The RF cartridge filters are the solution for effective reduction of chlorine and bad taste and odor. These filters provide low pressure drop and carbon fines released from the filter are much less compared to the same size GAC style cartridge filter.

Features:

- Ideal for POE (whole house) and other high flow rate applications
- Unique design reduces carbon fines in filtered water
- Very low pressure drop

Item #	Model #	Maximum Size	Micron	Capacity (Gallons)	Flow Rate (gpm)
36089	P-RF-10BV	4.5" X 10"	N/A	15,000 @ 3.0	10.0
36091	P-RF-20BV	4.5" X 20"	N/A	30,000 @ 6.0	10.0

AQUA FLO[®]
PLATINUM



IAPMO R & T Certified against NSF 42 for Material Safety Only

Aqua Flo Platinum Filters



Spun Poly Bonded (SPB) Cartridge Filters

The SPB filters are manufactured from 100% polypropylene which is resistant to chemical and less prone to bacterial attack. Also they do not impart any taste and odor to the water.

Features:

- Use on chlorinated or non-chlorinated supplies.
- Designed for purity, bacteria and chemical resistance
- Spun fibers form a true gradient
- Density from outer to inner surfaces

Item #	Model #	Maximum Size	Micron	Flow Rate (gpm)
36095	P-SPB-25-10	2.5" X 10"	25.0	5 gpm
36097	P-SPB-5-10	2.5" X 10"	5.0	5 gpm
36099	P-SPB-5-20	2.5" X 20"	5.0	10 gpm



IAPMO R & T Certified against NSF 42 for Material Safety Only



Polypropylene Melt Blown (PPMB) Filter Cartridges

The PPMB cartridge filters are made by thermally bonding polypropylene microfibers for higher filtration efficiency performance. The polypropylene material is chemical resistant and not prone to bacterial attack. They will also not add any taste, color and odor to the water. They are available in wide variety of sizes and micron ratings.

Features:

- Constructed from high quality polypropylene filter media for higher filtration efficiency
- Thermally bonded micro-fiber construction for high strength
- Available in micron ratings from 1 to 50 and lengths from 10"- 40"

Item #	Model #	Maximum Size	Micron	Flow Rate (gpm)
36198	P-PMB-10-5	2.5" X 10"	5	2 gpm
36199	P-PMB-10-10	2.5" X 10"	10	2 gpm
36200	P-PMB-10-25	2.5" X 10"	25	2 gpm
36202	P-PMB-20-1	2.5" X 20"	1	5 gpm
36203	P-PMB-20-5	2.5" X 20"	5	5 gpm
36204	P-PMB-20-10	2.5" X 20"	10	5 gpm
36205	P-PMB-20-25	2.5" X 20"	25	5 gpm
36249	P-PMB-10-1	2.5" X 10"	1	2 gpm
36250	P-PMB-10-50	2.5" X 10"	50	2 gpm
36251	P-PMB-20-50	2.5" X 20"	50	5 gpm
36252	P-PMB-30-1	2.5" X 30"	1	6 gpm
36254	P-PMB-30-25	2.5" X 30"	25	6 gpm



IAPMO R & T Certified against NSF 42 for Material Safety Only



*String Wound (SW) Polypropylene Cartridge Filters

SW cartridge filters are manufactured from polypropylene cord which is wound around the polypropylene core. These cartridge filters are economical solution for reduction of sediment, sand, rust and scale particles from the drinking water.

Features:

- String wound filters reduces sediment from a variety of liquids
- Low pressure drop
- Withstand high temperatures
- Wide chemical compatibility

Item #	Model #	Maximum Size	Micron	Flow Rate (gpm)
36101	P-SW-10-10	2.5" X 10"	10	10 gpm
36102	P-SW-1-20	2.5" X 20"	1	10 gpm
36104	P-SW-30-10	2.5" X 10"	30	10 gpm
36109	P-SW-5-10	2.5" X 10"	5	10 gpm
36138	P-SW-5-10BV	4.5" X 10"	5	15 gpm
36140	P-SW-25-10B	4.5" X 10"	25	15 gpm
36141	P-SW-1-20BV	4.5" X 20"	1	20 gpm
36142	P-SW-5-20BV	4.5" X 20"	5	20 gpm
36143	P-SW-25-20BV	4.5" X 20"	25	20 gpm
**36241	P-SW-100-20BV	4.5" X 20"	100	20 gpm

**Not certified

Aqua Flo Platinum Filters



Pleated Cellulose (PC) Filter Cartridges

The PC cartridge filters are made from pleated cellulose media and are recommended for general water filtration requirements.

Features:

- Pleated design maximizes dirt-holding capacity
- Designed for general water filtration purposes
- Nominal 20-micron rating
- Cellulose based material

Item #	Model #	Maximum Size	Micron	Flow Rate (gpm)
36154	P-PC-20-10	2.5" X 10"	20.0	10 gpm
36156	P-PC-20-10BV	4.5" X 10"	20.0	10 gpm
36157	P-PC-20-20BV	4.5" X 20"	20.0	20 gpm



NSF/ANSI 42 for Material Safety Only. Visit www.nsf.org for specific details on certification



Pleated Polyester Cartridge (PPC) Filter

The PPC cartridge filters are made from resin impregnated cellulose and polyester fibers. They are constructed with thermally bonded media with end caps and inner core heat sealed together.



Item #	Model #	Maximum Size	Micron	Flow Rate (gpm)
36122	P-PPC-5-10	2.5" X 10"	5.0	10 gpm
36130	P-PPC-5-10BV	4.5" X 10"	5.0	10 gpm
36134	P-PPC-5-20BV	4.5" X 20"	5.0	20 gpm

Features:

- Special formulation of resin impregnated cellulose and polyester fibers
- Provides higher wet strength than regular cellulose cartridges
- High flow rate and high dirt-holding capacity
- Wide Variety of sizes and micron ranges available



NSF/ANSI 42 for Material Safety Only. Visit www.nsf.org for specific details on certification



IAPMO R & T Certified against NSF 42 for Material Safety Only



Aqua Flo Economy Filters



Carbon Block (CB) Cartridge Filter



The CB cartridge filter is suitable for high capacity chlorine and bad taste and odor reduction from drinking water. These filters are also used for sediment filtration, making them a great choice for pre-filtering water for reverse osmosis

applications. They make an ideal choice for a wide range of residential, food service, commercial and industrial applications.

Features:

- High Dirt-Holding Tolerance
Maximizes Utilization of the Carbon Block
- High porosity maximizes utilization of the carbon block

Item #	Model #	Maximum Size	Micron	Capacity (Gallons)	Flow Rate (gpm)
26192	CCB-1-10	2.5" X 10"	1	10,000 gallons @ 1 gpm	1 gpm
26193	CCB-5-10	2.5" X 10"	5	6,000 gallons @ 1 gpm	1 gpm
26194	CB-0.5-10	2.5" X 10"	0.5	20,000 gallons @ 1 gpm	1 gpm
26195	CB-5-10	2.5" X 10"	5	6,000 gallons @ 1 gpm	1 gpm
26196	CB-10-10	2.5" X 10"	10	3,000 gallons @ 1 gpm	1 gpm
26197	CB-0.5-20	2.5" X 20"	0.5	45,000 gallons @ 2 gpm	2 gpm
26198	CB-5-20	2.5" X 20"	5	12,000 gallons @ 2 gpm	2 gpm
26199	CB-10-20	2.5" X 20"	10	6,000 gallons @ 2gpm	2 gpm
26201	CB-0.5-10BV	4.5" X 10"	0.5	50,000 gallons @ 2 gpm	2 gpm
26202	CB-5-10BV	4.5" X 10"	5	22,000 gallons @ 2 gpm	2 gpm
26203	CB-10-10BV	4.5" X 10"	10	15,000 gallons @ 2gpm	2 gpm
26204	CB-0.5-20BV	4.5" X 20"	0.5	150,000 gallons @ 4gpm	4 gpm
26205	CB-5-20BV	4.5" X 20"	5	40,000 gallons @ 4 gpm	4 gpm
26206	CB-10-20BV	4.5" X 20"	10	30,000 gallons @ 4 gpm	4 gpm

Dual Gradient (DG) Density Cartridge Filters

DG cartridge filters are made from 100% polypropylene. The progressively loose structure from inside to outside enhance cartridge performance in reduction of dirt, dust and other particles. The two separate gradient layers of the filter enhances the performance such that it achieves a much higher dirt-loading capacity compared to similar size sediment cartridge filters including spun and string-wound. They make an ideal sediment reduction choice for a wide range of residential, food service, commercial and industrial applications.



Features:

- No Fiber release and media migration
- Designed for purity, bacteria and chemical resistance
- Two Separate Gradient density layers enhance cartridge performance
- Three times the dirt-holding capacity than other traditional sediment filters

Item #	Model #	Maximum Size	Micron	Flow Rate (gpm)
26207	DG-25-1-10BV	4.5" X 10"	25/1	10 gpm
26208	DG-50-5-10BV	4.5" X 10"	50/5	10 gpm
26209	DG-75-25-10BV	4.5" X 10"	75/25	10 gpm
26210	DG-25-1-20BVV	4.5" x 20"	25/1	20 gpm
26211	DG-50-5-20BV	4.5" X 20"	50/5	20 gpm
26212	DG-75-25-20BV	4.5" X 20"	75/25	20 gpm

Impregnated Carbon Cellulose (ICC) Dual Purpose Filter

The ICC cartridge filter has a dual benefit for sediment filtration and reduction of chlorine and bad taste and odor from drinking water. These carbon wrap sediment cartridges consist of polypropylene melt blown core with carbon impregnated outer layer wrap. It is an economical solution for general water filtration requirements. This filter has high dirt-loading capacity and is recommended for chlorinated water supplies. These dual-purpose cartridges are well suited for residential applications, and are great polishing filters for closed loop water stream systems. The netting and reinforced support provide strength to the filter.



Item #	Model #	Maximum Size	Micron	Capacity (Gallons)	Flow Rate (gpm)
26278	ICC-5-10	2.5" X 10"	5	2,500 gallons @ 1 gpm	5 gpm
26189	ICC-20-20BV	4.5" X 20"	20	7,500 gallons @ 4 gpm	10 gpm

Features:

- Provides sediment filtration as well as taste/odor /chlorine reduction
- High dirt loading capacity
- External netting for additional strength

Impregnated Carbon Polyester (ICP) Dual Purpose Filter

The ICP cartridge filter has a dual benefit for sediment filtration and reduction of chlorine and bad taste and odor from drinking water. These carbon wrap sediment cartridges consist of polypropylene melt blown cores with carbon impregnated outer layer wraps. It is an economical solution for general water filtration requirements. This filter is recommended for chlorinated water supplies. These dual-purpose cartridges are well suited for residential applications and are great polishing filters for closed-loop water stream systems.

Item #	Model #	Maximum Size	Micron	Capacity (Gallons)	Flow Rate (gpm)
26190	ICP-10-10	2.5" X 10"	5	2,500 gallons @ 1 gpm	5 gpm

Features:

- Provides sediment filtration as well as taste/odor /chlorine reduction
- High dirt loading capacity
- External netting for additional strength

Material Information

End Cap Material - Polypropylene
 Core - Polypropylene
 Gasket - Silicon/PVC
 Filter Media - Carbon Impregnated Polyester
 Netting - Polypropylene



Pleated Polyester Reusable (PR) Cartridge Filter

PR cartridge filters are made from reusable polyester fibers which are pleated to maximize dirt holding capacity. These cartridge filters are multipurpose.

Item #	Model #	Maximum Size	Micron	Capacity (Gallons)	Flow Rate (gpm)
26242	PR-30-10BV	4.5" X 10"	30	24,000 @ 10.0 gpm	10 gpm
26243	PR-50-10BV	4.5" X 10"	50	24,000 @ 10.0 gpm	10 gpm
26244	PR-30-20BV	4.5" X 20"	30	48,000 @ 10.0 gpm	20 gpm

Features:

- Pleated design maximizes dirt-holding capacity
- Durable, versatile and reusable
- Polyester media is bacteria and chemical resistant
- Nominal 30-micron rating and nominal 50-micron rating



Radial Flow (RF) Granular Activated Carbon Cartridge Filters

The RF cartridge filters are the solution for effective reduction of chlorine and bad taste and odor. These filters provide low pressure drop and carbon fines released from the filter are much less compared to the same size GAC style cartridge filter.

Features:

- Ideal for POE (whole house) and other high flow rate applications
- Unique design reduces carbon fines in filtered water
- Very low pressure drop

Item #	Model #	Maximum Size	Micron	Capacity (Gallons)	Flow Rate (gpm)
26253	RF-20	2.5' X 20"	N/A	6,000 gallons @ 2 gpm	4 gpm
26254	RF-10	2.5" X 10"	N/A	3,000 gallons @ 1 gpm	1 gpm
26255	RF-10BV	4.5" X 10"	N/A	35,000 gallons @ 2 gpm	4 gpm
26256	RF-20BV	4.5" X 20"	N/A	70,000 gallons @ 4 gpm	8 gpm



Spun Poly Bonded (SPB) Cartridge Filters

The SPB filters are manufactured from 100% polypropylene which is resistant to chemical and less prone to bacterial attack. Also they do not impart any taste and odor to the water.

Features:

- Use on chlorinated or non-chlorinated supplies.
- Designed for purity, bacteria and chemical resistance
- Spun fibers form a true gradient
- Density from outer to inner surfaces

Item #	Model #	Maximum Size	Micron	Flow Rate (gpm)
26213	SPB-1-10	2.5" X 10"	1	4 gpm
26222	SPB-5-10	2.5" X 10"	5	5 gpm
26221	SPB-5-20	2.5" X 20"	5	10 gpm

Granular Activated (CGAC) Carbon Cartridge Filter

The CGAC cartridge filters are effective in reduction of chlorine and other bad taste and odor from drinking water.

CGAC cartridge filter contain coconut shell based activated carbon which is an environment friendly but also effective in reducing certain compounds better than the coal based granular activated carbon filter cartridges.



Features:

- Effective taste/odor/chlorine reduction
- Designed for maximum adsorption
- Post filter to reduce carbon fines

Item #	Model #	Maximum Size	Micron	Flow Rate (gpm)
26277	CGAC-10	2.5" X 10"	5,000 gallons @ 1.0 gpm	1 gpm @ 7 psi drop
26186	CGAC-20	2.5" X 20"	10,000 gallons @ 2.0 gpm	2 gpm @ 15 psi drop
26187	CGAC-BV	4.5" X 10"	12,500 gallons @ 2.0 gpm	2 gpm @ 5 psi drop
26188	CGAC-20BV	4.5" X 20"	25,000 gallons @ 4.0 gpm	4 gpm @ 5 psi drop

Polypropylene Melt Blown (PPMB) Filter Cartridges

The PPMB cartridge filters are made by thermally bonding polypropylene micro-fibers for higher filtration efficiency performance. The polypropylene material is chemical resistant and not prone to bacterial attack. They will also not add any taste, color and odor to the water. They are available in wide variety of sizes and micron ratings.



Features:

- Constructed from high quality polypropylene filter media for higher filtration efficiency
- Thermally bonded micro-fiber construction for high strength
- Available in micron ratings from 1 to 50 and lengths from 10"- 40"

Item #	Model #	Maximum Size	Micron	Flow Rate (gpm)
26269	PPMB-5-10	2.5" X 10"	5	3 gpm
26223	PPMB-10-10	2.5" X 10"	10	4 gpm
26224	PPMB-25-10	2.5" X 10"	25	5 gpm
26225	PPMB-50-10	2.5" X 10"	50	8 gpm
26226	PPMB-1-20	2.5" X 20"	1	4 gpm
26227	PPMB-5-20	2.5" X 20"	5	7 gpm
26228	PPMB-10-20	2.5" X 20"	10	9 gpm
26229	PPMB-25-20	2.5" X 20"	25	11 gpm
26230	PPMB-50-20	2.5" X 20"	50	15 gpm
26231	PPMB-1-40	2.5" X 40"	1	8 gpm
26232	PPMB-5-40	2.5" X 40"	5	14 gpm
26233	PPMB-20-40	2.5" X 40"	20	20 gpm
26234	PPMB-1-10BV	4.5" X 10"	1	6 gpm
26235	PPMB-5-10BV	4.5" X 10"	5	10 gpm
26236	PPMB-10-10BV	4.5" X 10"	10	11 gpm
26237	PPMB-20-10BV	4.5" X 10"	20	14 gpm
26238	PPMB-1-20BV	4.5" X 20"	1	12 gpm
26239	PPMB-5-20BV	4.5" X 20"	5	20 gpm
26240	PPMB-10-20BV	4.5" X 20"	10	20 gpm
26241	PPMB-20-20BV	4.5" X 20"	20	20 gpm

String Wound (SW) Polypropylene Cartridge Filters

SW cartridge filters are manufactured from polypropylene cord which is wound around the polypropylene core. These cartridge filters are economical solution for reduction of sediment, sand, rust and scale particles from the drinking water.

Item #	Model #	Maximum Size	Micron	Flow Rate (gpm)
26273	SW-5-10	2.5" X 10"	5	5 gpm
26246	SW-10-10	2.5" X 10"	10	7 gpm
26247	SW-30-10	2.5" X 10"	30	10 gpm
26249	SW-50-10	2.5" X 10"	50	10 gpm
26250	SW-1-20	2.5" X 20"	1	15 gpm
26251	SW-5-20	2.5" X 20"	5	15 gpm
26252	SW-30-10BV	4.5" X 10"	30	20 gpm

Features:

- String wound filters reduces sediment from a variety of liquids
- Low pressure drop
- Withstand high temperatures
- Wide chemical compatibility



Aqua Flo Economy Filters

AQUA FLO®

Pleated Polyester Cartridge (PPC) Filter



The PPC cartridge filters are made from resin impregnated cellulose and polyester fibers. They are constructed with thermally bonded media with end caps and inner core heat sealed together.

Features:

- ➔ Special formulation of resin impregnated cellulose and polyester fibers
- ➔ Provides higher wet strength than regular cellulose cartridges
- ➔ High flow rate and high dirt-holding capacity
- ➔ Wide Variety of sizes and micron ranges available

Item #	Model #	Maximum Size	Micron	Flow Rate (gpm)
26174	PPC-1-10	2.5" X 10"	1	5 gpm
26175	PPC-5-10	2.5" X 10"	5	7 gpm
26176	PPC-1-20	2.5" X 20"	1	10 gpm
26177	PPC-5-20	2.5" X 20"	5	13 gpm
26178	PPC-5-10BV	4.5" X 10"	5	18 gpm
26179	PPC-20-10BV	4.5" X 10"	20	20 gpm
26180	PPC-5-20BV	4.5" X 20"	5	20 gpm
26181	PPC-20-20BV	4.5" X 20"	20	35 gpm

AQUA FLO®

Pleated Cellulose (PC) Filter Cartridges



The PC cartridge filters are made from pleated cellulose media and are recommended for general water filtration requirements.

Features:

- ➔ Pleated design maximizes dirt-holding capacity
- ➔ Designed for general water filtration purposes
- ➔ Nominal 20-micron rating
- ➔ Cellulose based material

Item #	Model #	Maximum Size	Micron	Flow Rate (gpm)
26276	PC-20-10	2.5" X 10"	20	10 gpm
26182	PC-20-20	2.5" X 20"	20	15 gpm
26183	PC-20-10BV	4.5" X 10"	20	20 gpm
26184	PC-20-20BV	4.5" X 20"	20	35 gpm

Specialty Filters

Water Softening

These cation exchange softening cartridges utilize a bed of sodium form cation resin beads to reduce hardness and scale deposits. The convenient and space-saving design of our WS Series cartridges means that softened water can be provided easily and cost effectively at the exact point of need.

Item #	Model #	Maximum Size	Capacity (grains)
36242	P-WS-10	2.5" X 10"	1,414
36243	P-WS-20	2.5" X 20"	2,520
36244	P-WS-20BV	4.5" X 20"	6,295

Deionization

These high-capacity, semi-conductor grade resin cartridges are ideal for use in pharmaceuticals, medical laboratories, cosmetics, and circuit board printing applications.

Item #	Model #	Maximum Size
36179	P-DI-10	2.5" X 10"
36180	P-DI-20	2.5" X 20"
36178	P-DI-20BB	4.5" X 20"

Iron Reduction

This cartridge helps to eliminate the orange and brown stains often found in sinks, toilets, tubs and other plumbing fixtures.

Item #	Model #	Maximum Size	Capacity (ppm)
36236	P-IR-20BV	4.5" X 20"	1,492 @ 3gpm

In-line Cartridge

Sealed in-line filters feature coconut shell, granular activated carbon, and are designed to reduce unwanted taste, odor and chlorine taste and odor.

Item #	Model #	Maximum Size	Micron
36070	P-IL-GAC-1/4	2" x 10	5
36248	P-IL-CGAC-3/8	2" x 10	5
36230	P-IL-PH-1/4	2" x 10	20

Ice Maker

High grade coconut shell activated carbon and a filter element for sediment removal make this the ideal choice for ice makers and water dispensers. Enjoy clean, clear, great tasting water and ice cubes.

Item #	Model #	Maximum Size
26003	WIM14	2.25" X 8"

Stainless Steel Housings



Features:

- Heavy-duty units for smaller filtration systems and point-of-use applications
- Brushed 304 stainless steel sump with a cast brass / nickel plated head
- Ideal for high-pressure / hot water applications
- Utilizes double open-end cartridges



Tin Core-String Wound Cartridges

- Tin core and string wound natural cotton media is suitable for general purpose high temperature filter applications with water, oils, solvents, paints and other non-FDA (non-potable) applications.
- Maximum Cartridge Temperature - 180°F (82°C)
- 2.5" O.D. Core x 10" Length (suitable for #10 and ST-1 Housings)
- Available in 5, 10, 25, 50 micron ratings

304SS Core String Wound Cartridges

- Maximum Cartridge Temperature - 180°F (82°C)

Materials of Construction	
Housing	Brushed 304 Stainless Steel
Head	Brass / Nickel Plated
Max Temperature	180°F (82°C)
Pipe Size	3/4" NPT
Sealing Gaskets	Buna-N, Cellulose Fiber

Cartridges

Item #	DESCRIPTION	WEIGHT (LBS)
26134	Sediment, 10" 10 Micron, Hot Water, Tin Core, Non-potable	0.5
26135	Sediment, 10" 25 Micron, Hot Water, Tin Core, Non-potable	0.5
26136	Sediment, 10" 50 Micron, Hot Water, Tin Core, Non-potable	0.5
26137	Sediment, 10" 5 Micron, Hot Water, Non-potable SS	0.5
26138	Sediment, 10" 10 Micron, Hot Water, Non-potable SS	0.5
26139	Sediment, 10" 25 Micron, Hot Water, Non-potable SS	0.5
26140	Sediment, 10" 50 Micron, Hot Water, Non-potable SS	0.5
26141	Sediment, 10" 5 Micron, Hot Water, Tin Core, Non-potable	0.5

- 2.5 O.D. Core x 10" Length (suitable for #10 and ST-1 Housings)
- Available in 5, 10, 25, 50 micron ratings

Housings

Item #	Model	Maximum Dimensions	Flow Rate (gpm)	Maximum Pressure
36146	SS-1	14 1/8" x 4 1/8" (360mm x 105mm)	10 gpm (38 lpm)	250 psi (17.2 bar)
36147	SS-2	24" x 4 1/8" (610mm x 105mm)	15 gpm (57 lpm)	250 psi (17.2 bar)
36148	SS-3	33 5/8" x 4 1/8" (853mm x 105mm)	20 gpm (76 lpm)	250 psi (17.2 bar)

* Maximum cartridge diameter 3" (76mm)

#36145 Side Stream Filter Assembly

Pre-Assembled SS-1 Housing with stainless steel flow indicator and brass shutoffs.

Side stream filters are primarily used for filtering a portion of the water in a closed loop boiler system to protect the boiler, controls and circulating pumps

Dimensions: 14 1/8" (h) x 20 3/4" (w) x 4 1/8" (d)



Bag Filters

BF Series (Polypropylene Felt)

- Filtration ratings from 1 to 200 microns to comply with any filtration requirement
- Manufactured from felt due to its high solids loading capabilities versus similar mesh fabrics
- The material is created by needle-punching two layers of synthetic fibers together in a supporting scrim
- A glazed finish, created by melting the outermost surface fibers, is used to produce a bond that reduces the possibility of migration.

Item #	Model #	Maximum Size	Micron
36184	P-BF-410-1	4" X 10"	1
36185	P-BF-410-10	4" X 10"	10
36186	P-BF-410-100	4" X 10"	100
36187	P-BF-410-25	4" X 10"	25
36188	P-BF-410-5	4" X 10"	5
36189	P-BF-410-50	4" X 10"	50
36190	P-BF-420-1	4" X 20"	1
36191	P-BF-420-10	4" X 20"	10
36192	P-BF-420-100	4" X 20"	100
36193	P-BF-420-200	4" X 20"	200
36194	P-BF-420-25	4" X 20"	25
36195	P-BF-420-5	4" X 20"	5
36196	P-BF-420-50	4" X 20"	50

High Flow Stainless Steel Housings

Features

- Side Inlet / Outlet connections
- Designed for industrial and commercial application.
- Stainless steel 304/316L heavy duty construction
- V Clamp Band for quick cartridge replacement
- Standard housings accept OD2.5" DOE cartridge

Item #	Model	Recommended Max. Flowrates GPM (L/S)*	Max No. of Cartridges	Height x Outside Diameter Inches (mm)
36222	Housing,P-SS-BC-4	28 (1.77)	4 x 1	23.8" x 12.4"(603 x 315)
36223	Housing,P-SS-BC-8	56 (3.53)	4 x 2	33.8" x 12.4"(857 x 315)
36219	Housing,P-SS-BC-12	84 (5.30)	4 x 3	43.8" x 12.4"(1111 x 315)
36220	Housing,P-SS-BC-16	110 (6.94)	4 x 4	53.8" x 12.4"(1365 x 315)
36221	Housing,P-SS-BC-20	125 (7.89)	5 x 4	53.8" x 12.4"(1365 x 315)

* Flowrate is for housing. Flow rate of the cartridges may also be a factor depending upon cartridge used.

Inlet/Outlets: 2" MNPT Vent: 1/4" FNPT Drains: 1/2" FNPT

Max cartridge length: 9 3/4 or 10" (248mm or 254 mm)

Max cartridge diameter: 2.5"

Design Pressure: 150PSI (10.3 Bar)

Design Temperature: 195°F (90.5°C)



Housing, P-SS-BC-8

Accessories



Sump Wrenches

#26007 - Wrench with six notches fits all 10" clear housings.

#92508 - Wrench, H-PR-10 and H-PR-20 Models

#92509 - Wrench, Big Valve Housings, H-PR-BV Models



Aqua Flo Sump O-Rings

#92512 - O-Ring, Sump, Big Value Housings, H-PR-BV

#92513 - O-Ring, Sump, H-PR-10 and H-PR-20

#92060 - O-Ring, Sump, WCT34SS and WVIH34SS

#26022 - O-Ring, Sump, APC and VIH



Accessories:

Chemical Feed Pumps
Pro Chemicals
Test Kits
Mazzei Injectors
John Guest Fittings



Chemical Feed Pumps

45 Pump Series Single Head Adjustable Rate

How it Works

Stenner's adjustable metering pump is built with three detachable components: the motor, feed rate control and pump head. Outputs are dependent upon three factors: the rpm of the motor gears, the percentage setting on the feed rate control and the size of the peristaltic pump tube. All Stenner metering pumps have a 3-point roller design in the pump head, which acts as a check valve to prevent back flow, siphoning, overdosing and loss of prime.

The motor shaft rotates at a fixed rpm which drives the adjustable feed rate control to intermittently engage the roller assembly within the pump head. The chemical solution in the pump tube is captured between the rollers as they rotate and compress the tube. As the rollers advance, the squeezed tube section regains its original form and generates a vacuum, creating the self-priming feature that delivers a constant flow unaffected by the outlet pressure.



STENNER PUMPS

Advantages:

- ⇒ Self-priming up to 25 feet does not lose prime
- ⇒ Can pump off-gassing solutions
- ⇒ Solutions contained in tube, not exposed to pump components or air
- ⇒ Sub-assemblies fit together without tools, easy service or conversion to another model
- ⇒ Pump head universal to all Stenner pumps
- ⇒ Can run dry without damage
- ⇒ Will not clog from dirt or debris
- ⇒ Reproducible outputs within 2%
- ⇒ Adjustable feed rate control from 5% - 100% in 2.5% increments
- ⇒ Pump tubes accept a variety of chemical
- ⇒ 1 Year Guarantee from date of manufacture

the patented mechanical feed rate control allows the pump's output to be scaled from 5% to 100% with the simple turn of the dial.

Chemical Feed Pumps

45MHP2

100 psi (6.9 bar)
max 3 gpd (11 lpd)

Outputs @ 60Hz

Gallons per day: 0.2 to 3.0
Gallons per hour: 0.01 to 0.13
Liters per day: 0.8 to 11.4
Liters per hour: 0.03 to 0.48
Ounces per minute: 0.02 to 0.27
Milliliter per minute: 0.56 to 7.92

Outputs @ 50Hz

Liters per day: 0.6 to 9.1
Liters per hour: 0.03 to 0.38
Milliliters per minute: 0.31 to 6.32

Maximum Operating Temperature

12° F (52° C)

Amp Draw

1.7 120V; 0.9 220V, 230V, 250V

Dimensions (l x w x h)

10.6 x 5.3 x 6.0 in
(26.9 x 13.4 x 15.2 cm)

Shipping Weight

9 lbs (4 kg)

45MHP10

100 psi (6.9 bar)
10 gpd (38 lpd)

Outputs @ 60Hz

Gallons per day: 0.5 to 10.0
Gallons per hour: 0.02 to 0.42
Liters per day: 1.9 to 37.9
Liters per hour: 0.08 to 1.58
Ounces per minute: 0.04 to 0.89
Milliliter per minute: 1.32 to 26.32

Outputs @ 50Hz

Liters per day: 1.5 to 30.3
Liters per hour: 0.06 to 1.26
Milliliters per minute: 1.04 to 21.04

Discharge Pressure

26-100 psi (1.7-6.9 bar)

Voltage

120V 60Hz; 220V 60Hz
230V 50Hz; 250V 50Hz International

Motor

shaded pole; 26 rpm; 1/30 HP

Suction Lift

25' (7.6 m))

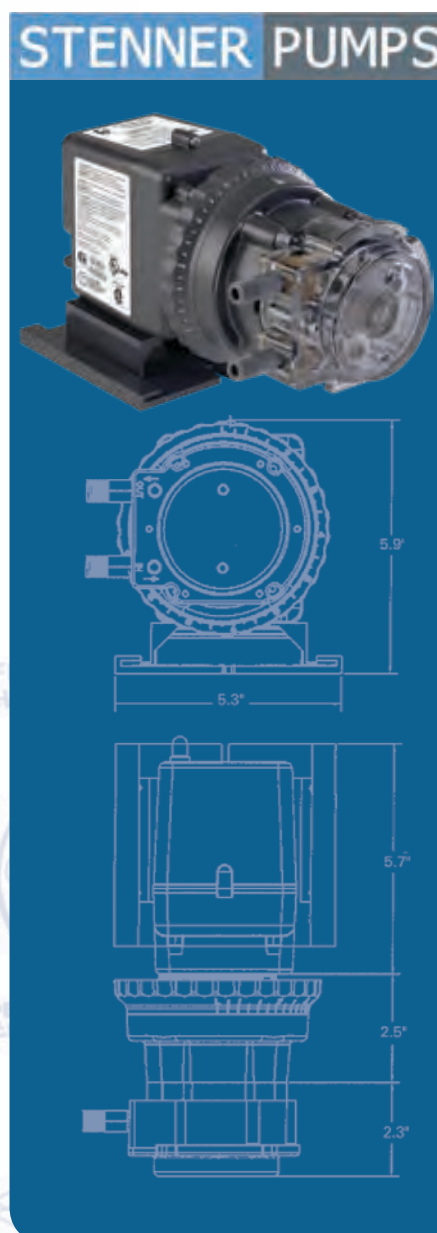

Item #		Model	Tube	Feed Rate Setting: Outputs per day in US Gallons @ 60Hz										
CDN #	US #			L	1	2	3	4	5	6	7	8	9	10
11873	11873	45MHP2	#1	0.2	0.3	0.6	0.9	1.2	1.5	1.8	2.1	2.4	2.7	3
11874	11810													
11876	11809	45MHP10	#2	0.5	1	2	3	4	5	6	7	8	9	10
11879	11808													

Item #	Description
11873	45MHP2-110v, ¼" tubing
11874	45MHP2-220v, ¼" tubing
11876	45MHP10-110v, ¼" tubing
11879	45MHP10-220v, ¼" tubing

Chemical Feed Pumps

85 Pump Series Single Head Adjustable Rate

How it Works

Stenner's fixed output metering pump is built with two detachable components: the motor and pump head. Outputs are dependent upon the rpm of the motor gears and the size of the peristaltic pump tube.

The fixed rate pump has no output adjustment. All Stenner metering pumps have a 3-point roller design in the pump head, which acts as a check valve to prevent back flow, siphoning, overdosing and loss of prime.

The motor's output shaft rotates at a fixed rpm which drives the roller assembly within the pump head. The chemical solution in the pump tube is captured between the rollers as they rotate and compress the tube. As the rollers advance, the squeezed tube section regains its original form and generates a vacuum, creating the self-priming feature that delivers a constant flow unaffected by the outlet pressure.



STENNER PUMPS

Advantages:

- ➔ Self-priming up to 25 feet and does not lose prime
- ➔ Can pump off-gassing solutions
- ➔ Solutions contained in tube, not exposed to pump components or air
- ➔ Subassemblies fit together without tools; easy service or conversion to another model
- ➔ Pump head universal to all Stenner pumps
- ➔ Can run dry without damage
- ➔ Will not clog from dirt or debris
- ➔ Reproducible outputs within 2%
- ➔ Adjustable feed rate control from 5%-100% in 2.5% increments
- ➔ Pump tubes accept a variety of chemicals

Outputs @ 60Hz

Gallons per day: 0.8 to 17.0
 Gallons per hour: 0.03 to 0.71
 Liters per day: 3.0 to 64.4
 Liters per hour: 0.13 to 2.68
 Ounces per minute: 0.07 to 1.51
 Milliliter per minute: 2.08 to 44.65

Outputs @ 50Hz

Liters per day: 2.4 to 51.5
 Liters per hour: 0.10 to 2.15
 Milliliters per minute: 1.67 to 35.76

Discharge Pressure

26-100 psi (1.7-6.9 bar)

Voltage

Voltage 120V 60Hz; 220V 60Hz/230V 50Hz; 250V 50Hz International

Motor

shaded pole; 44 rpm; 1/30 HP

Suction Lift

25' (7.6 m)

Maximum Operating Temperature

125° F (52° C)

Amp Draw

1.7 120V; 0.9 220V, 230V, 250V

Dimensions (l x w x h)

10.6 x 5.3 x 6.0 in
 (26.9 x 13.4 x 15.2 cm)

Shipping Weight

9 lbs (4 kg)

Item #		Model	Tube	Feed Rate Setting: Outputs per day in US Gallons @ 60Hz										
CDN #	US #			L	1	2	3	4	5	6	7	8	9	10
11880	11852	85MHP5	#1	0.3	0.5	1.0	1.5	2.0	2.5	3.0	3.5	4.0	4.5	5.0
11872	11853													

Item #	Description
11880	STENNER-PUMP-85MHP5-110
11872	STENNER-PUMP-85MHP5-220

Chemical Feed Pumps

Materials of Construction

All Housings: Lexan® polycarbonate plastic
Pump tube & check valve duckbill: Santoprene® FDA approved

Pump tube: Tygothane® FDA approved

Checkvalve duckbill (w/Tygothane tube): Pellathane®

Suction/discharge tubing & ferrules (1/4" & 6 mm):

LDPE polyethylene,

NSF/FDA approved

Tube fittings, connecting nuts, check valve fitting,

weighted strainer: Type 1 Rigid PVC-NSF listed

All fasteners: Stainless Steel

Lexan® is a registered trademark of General Electric.

Santoprene® is a registered trademark of Advanced Elastomer system

Tygothane® is a registered trademark of Saint-Gobain

Performance Plastics

Pellathane® is a registered trademark of The Dow Company

Company

Agency listings

Santoprene®: UL, CSA, CE, NSF-50, NSF-61

Tygothane®: UL, CSA, CE

Accessories shipped with each pump

3 connecting nuts 1/4" or 3/8"

3 ferrules 1/4" & 6 mm or 2 ferrules 3/8"

1 injection check valve

1 weighted strainer

1 20' roll of suction/discharge tubing 1/4" or 3/8" white or UV

black or 6 mm (Europe) white

1 spare pump tube

1 mounting bracket

1 installation manual

STENNER PUMPS



Stenner Pump Control Module

How It Works:

The Pump Control Module (PCM) is a component of the proportional feed system, which delivers repeatable doses regardless of the system's flow rate. The system is used in applications requiring proportional chemical injection.

The proportional feed system, Stenner refers to as the PCM system consists of three components:

- ➔ PCM – pump control module
- ➔ Single head fixed output pump (45 or 85 model)
- ➔ Dry contact water meter

The water meter sends a pulse signal to the PCM which activates the pump to deliver the desired dose based on water volume. The PCM turns on the pump for the set duration determined to inject the solution into the water line.

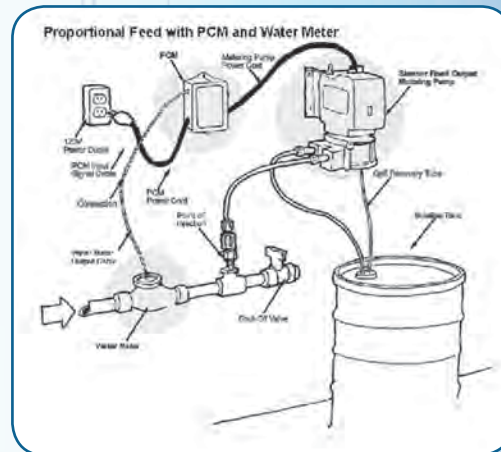

Water Meters

Features:

- ➔ Reed switch
- ➔ Dry contact
- ➔ Power not required

Material:

- ➔ Body: Cast bronze
- ➔ Internal: Engineered thermoplastic
- ➔ Magnet: Alnico

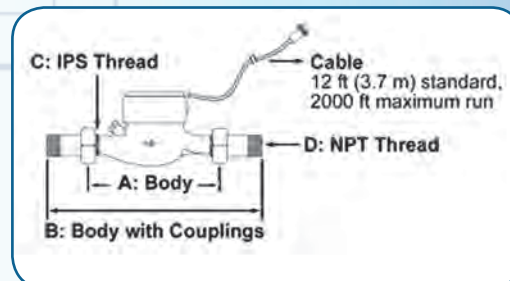

Size	A Body	B Body w Couplings	C IPS Thread	D NPT Thread
3/4"	7 1/2" (19.1 cm)	12 5/8" (32.1 cm)	1" (2.5 cm)	3/4" (1.9 cm)
1"	10 1/4" (26.0 cm)	15 5/8" (36.7 cm)	1 1/4" (3.2 cm)	1" (2.5 cm)
1 1/2"	11 3/4" (29.9 cm)	17 5/8" (44.8 cm)	2" (5.1 cm)	1 1/2" (3.8 cm)
2"	11 3/4" (29.9 cm)	17 5/8" (44.8 cm)	2 1/2" (6.4 cm)	2" (5.1 cm)

Water Meters		Min Flow	Max Flow	Max Operating Temp	Max Operating Pressure
Part #	Description	(Gallons Per Minute)			
80060050	Meter, Contacting Stenner WM0751G 3/4" 1Gallon/Pulse	0.22	22	105 F (40 C)	150 psi
80060051	Meter, Contacting Stenner WM1001G 1" 1Gallon/Pulse	0.44	52	105 F (40 C)	150 psi
80060052	Meter, Contacting, 1.5" 1.0 GPC, 404(Gal/Contact)	0.88	88	105 F (40 C)	150 psi
80060053	Meter, Contacting, 2.0" 1.0 GPC, 504(Gal/Contact)	1.98	132	105 F (40 C)	150 psi
27339	Timer, Stenner, Pump Control Module 5, 0.5 to 5.0 seconds				

Flow Switch (Low Flow Rate – SPDT)

Description:

For use on liquid lines using water, ethylene glycol solutions, or other liquids not corrosive to the brass or phosphor bronze parts. The SPDT contact switch is activated by a low flow rate; however, it has a large flow capacity with a minimum pressure drop.

Applications:

- ➔ Water purification and treatment systems
- ➔ Booster pumps
- ➔ Fast shutdown on high input boilers to guard against circulation failure
- ➔ Cooling systems for electronic tubes, bearings, and compressors



F61KD-4

Item #	Description	Inlet and Outlet Size Female NPT	Enclosure NEMA Type	Adjustment Range - GPM (L/Min)		Maximum Liquid Temp	Minimum Liquid Temp	Maximum Liquid Pressure
				R to Y Closes Flow Increase	R to Y Opens Flow Decrease			
85251	F61KD-4C Flow Switch (Low Flow Rate - SPDT)	3/4" x 3/4" (19mm x 19mm)	1	Min 0.6 (2.27) Max 1.1 (4.17)	Min 0.3 (1.14) Max 0.9 (3.4)	250°F (121°C)	32°F (0°C)	150 psig (1034 kPa)

Item #	Description
32881	K3VTC1 - KOP KIT
32880	K4VTC1 - KOP KIT

Dimensions
5 1/32" h x 4" w x 2 13/16" d
127mm x 102mm x 71mm)

Electrical	120 VAC
Horsepower	1
AC Full Load A	16
AC Locked Rotor A	96
Non-Inductive or Resistance Load A	16
Pilot Duty	125 VA, 24/277 VAC

Pulsafeeder Kopkit



Kopkit®

Available for every model, the KOPkit provides an economically priced package of parts required for routine maintenance. The kit typically contains new valve cartridges with o-rings, head, diaphragm, secondary o-ring seal, head screws and washers.

Retention Tanks

Made from a unique 3 piece internal construction that allows for consistent engineered dome profiles and integrally bonded connections that lead to longer tank life. Its heavy duty base is molded out of ABS for maximum strength and durability. And, It has a removable schedule 80 PVC bottom connection that can be "accessorized" for increased installation flexibility.

- ➔ Durable PVC water connection.
- ➔ Flexwave tanks are made in the USA and built to comply with NSF/ANSI Std 61
- ➔ 5 year warranty



FWC Contact Retention Tanks - Dimensions & Capacities

Part #	Description	Total Tank Volume		Height		Diameter		Socket Glue Connection	FPT	Total Weight	
		Gallons	Litres	In	Cm	In	Cm			Lbs	Kilos
33201-1	AFLU30-EZ	30	114	42.5	108	16.5	41.8	1 1/4"schd-80	1 1/4"	23.0	10.4
33202-1	AFLU40-EZ	40	151	53.4	135.6	16.5	41.8	1 1/4"schd-80	1 1/4"	31.0	14.1
33203-1	AFLU40SQ-EZ	40	151	36.9	93.8	21.4	54.2	1 1/4"schd-80	1 1/4"	33.1	15.0
33204-1	AFLU80-EZ	80	303	64.1	162.8	21.4	54.2	1 1/4"schd-80	1 1/4"	60.0	27.0
33205-1	AFLU120-EZ	120	454	71.5	181.6	24.2	61.4	1 1/4"schd-80	1 1/4"	83.5	38.0

Maximum working temperature, internal & external 120F. Materials of Construction: Tank top and bottom domes injection molded copolymer polypropylene. Shell extruded polypropylene. Outer shell composite construction with fiberglass coated with epoxy resin. Base is injection molded ABS. Top and side ports are stainless steel reinforced.

BAF Mixing Tank - Dimensions & Capacities

Part #	Description	Total Tank Volume		Height		Diameter		Thread Connection	Outlet Connection at top of tank	Total Weight	
		Gallons	Litres	In	Cm	In	Cm			Lbs	Kilos
33217	BAF 80	80	303	64.1	163	21.4	54.4	1 1/4"NPT	1 1/4" FPT	23.0	10.4
33211	BAF 120	119	450	71.5	182	21.4	54.4	1 1/4"NPT	1 1/4" FPT	31.0	14.1

Maximum working pressure 100 PSI. Maximum working temperature, internal & external 120F. Materials of Construction: Copolymer polypropylene wrapped with fiberglass coated with epoxy resin. Base is rigid ABS. Inner baffle is a copolymer polypropylene with a PVC sch 40 standpipe and diffuser cap. Top port is stainless steel reinforced and bottom connections are a 1 1/4" NPT schedule 80- connection

Mixing Tanks



The Mixmaster(BAF) Series tanks are a retention tank with an internal baffle and diffuser which improves mixing and increases the retention time improving the effectiveness of chemical treatment of water for disinfection or mineral removal. Great for killing bacteria or for agricultural applications.

- ➔ Polypropylene tank reinforced with fiberglass sealed with epoxy resin.
- ➔ Cross- link polyethylene upper and lower water chamber. Standpipe and diffuser 1-1/4"pvc sch 40

Metal Storage Tanks for Reverse Osmosis Applications

Water goes through a reverse osmosis membrane very slowly and people don't have the patience to wait a long time to get a glass of water. For this reason the residential RO units need a water storage tank to store the purified water. The RO tanks can deliver stable and constant water flow when the faucet is opened.

To avoid bad odors from the diaphragm, all of the tank diaphragms are post-cured before assembly, to eliminate the possibility of odors from the tank.

Tanks are NSF approved under standard 58, and CE approved under the PED (pressure equipment directive).



- ➔ Maximum Working Pressure: 100PSI
- ➔ All Tanks are Pre-charged at 7 PSI
- ➔ Fittings sold separately
- ➔ NSF 58 certified



Item #	Description	Port	Capacity gal (liters)	Diameter inch (mm)	Height inch (mm)	Color	Shipping Weight lbs (kg)
92371	PRO-3.2	1/4" NPT	3.2 (12)	8.98 (228)	13.8 (345)	White	9.9 (4.5)
92372	PRO-11	3/4" NPT	11 (41.6)	14.97 (380)	21.2(530)	Blue	28 (12.7)
92373	PRO-20	3/4" NPT	20 (71.7)	14.97 (380)	28.8 (720)	Blue	39 (17.17)

Shut-off Valve for 1/4" NPT Tank Item #	Description
PPSV500822W	Shut Off Valve, 1/4" QC X 1/4" NPTF
PPSV501222W	Shut Off Valve, 3/8" QC X 1/4" NPTF
80704	Shut Off Valve, 3/8" Comp Nut X 1/4" NPTF
Shut-off Valve for 3/4" NPT Tank Item #	Description
92295	Kit, 3/8" Comp Nut Shut-off valve X 3/4" NPTF

Chemicals



Sani-System Liquid Sanitizer Concentrate

Sani-System is the only EPA & NSF approved sanitizer for use in water softeners and reverse osmosis units. It's proven to kill 99.99% of harmful bacteria without the use of chlorine, oxidizers or acids that can harm system equipment parts and resin. The exact pre-measured doses of concentrated

Simple to Use:

For water softeners it is as simple as pouring into the brine well or brine tank and manually regenerating the unit. For reverse osmosis units, simply remove the cartridges and place the packet contents in the first housing and flush. Sani-System is the only sanitizer on the market proven by the WQA to safely sanitize an RO unit membrane.

User Benefits:

- Faster, easier and safer than other alternative sanitizers
- Easy & reliable single dose packages
- 99.99% effective kill rate against harmful bacteria
- Only sanitizer on market proven by WQA to sanitize membrane

Technical Information:

- Sani-System is a clear liquid and will react to oxidizers
- Routine storage. Rubber gloves are suggested when handling. Read all relevant MSDS before handling.
- Do not mix with other chemicals
- Certified to NSF/ANSI 60 Standards

Part #	Description
50035	Sani-System RO Sanitizer 0.25 fl.oz (24 Packets)
50032	Sani-System Water Softener Sanitizer 0.5 fl.oz (24 Packets)

Chemicals

Pro Chemicals

Pro Chemicals provides a diverse portfolio of water softener cleaners designed to clean, restore and maintain the life of water softeners. These products are formulated to treat water softeners with iron or for daily preventative maintenance.

Rust Out® Water Softener Cleaner/iron remover

Rust Out® chemically removes iron and rust build-up that coats the resin bead and fouls the water softener. Rust Out changes rust and iron into a clear solution that easily rinses away and does not contain harsh or abrasive chemicals that damage fiberglass, porcelain or acrylic finishes. The advanced formula contains more than five chemicals that are formulated to clean, restore and maintain the life of water softeners. Rust Out can also be used to clean tough rust stains from toilets, sinks, tubs, white clothes and exterior surfaces.



Item #	Description
45126	Rust Out - 1.5 lb. Bottle
45127	Rust Out - 5 lb. Bottle
45128	Rust Out - 50 lb Pail



Res Care® Liquid Resin Cleaning Solution

Res Care® is a specially formulated liquid cleaner designed to remove limited iron, manganese, silt, metal particles and organic compounds that cause softener inefficiencies. Regular use of Res Care will restore the softener back to peak efficiency and maintain the life of the unit. For best results use a Res Care Automatic Feeder or manually add during regeneration to prevent mineral build-up.

Item #	Description
45147	Res Care - 1 gal. (128 oz) Bottle
80030022	Res Care - 64 oz Bottle (Easy Feeder Refill)
45148	Res Care - 1 qt. (32 oz) Bottle

Chemicals

Easy Feeder

The Pro Easy Feeder automatically dispenses the right amount of Pro Res Care Cleaning Solution to maintain water softener efficiency. The Pro Easy Feeder is non-electric and easy to install and use. For use with 64 oz bottles of Res Care.



Item #	Description
55030005	Easy Feeder - 0.5 oz/day Feeder
55030006	Easy Feeder - 1.0 oz/day Feeder



Pot® Perm Greensand Iron Filter Regenerant

Pro Pot Perm is an iron filter regenerant and a strong oxidizing agent that converts dissolved iron and/or manganese to insoluble oxides which can easily be removed through filtration. As an iron filter regenerant, Pot Perm regenerates and oxidizes greensand iron filter media, restoring the exchange capacity of the unit.

Item #	Description
45143-1	Pot Perm - 4.75 Lb. Bottle
45145-1	Pot Perm - 10 Lb. Bottle
50010	Pot Perm - 55 Lb. Bottle

Chemicals

Part #	Description
45138	Ban T - 1.5 lb. Bottle

Ban T® Alkaline Water Neutralizer

Ban T® (formerly called Pro-Citric Acid) is specifically formulated to effectively lower pH and remove iron and other contaminants from fouled water softeners. Ban T should be used as preventative maintenance on all water softeners in areas with moderate iron content to clean, restore and maintain the life of the softener. Ban T is an environmentally-friendly cleaning agent that removes hard water deposits and moderate iron staining from household fixtures.



Neutra Sul® - Eliminate Rotten Egg Smell Professional Grade Oxidizer

Protects against irregular coloring and rotten egg smells in treated water. Pro Neutra Sul® is formulated to neutralize the rotten egg smell and pollutants from any water supply through oxidation. Neutra Sul should be used in place of Hydrogen Peroxide 7% solution to prevent the formation of colors, tastes, corrosion and scaling by pollution degradation. Pro Neutra Sul is NSF Certified to meet NSF/ANSI Standard 60 for drinking water additives.

Part #	Description
50023	Neutra Sul -1 gallon Bottle



Neutra 7® Acid Water Neutralizer®

Neutra 7® (formerly called Pro Soda Ash) is a proprietary alkaline blend which neutralizes acid water and keeps the injection point clean. This helps to eliminate corrosion of piping, pressure tanks, water heaters and fixtures without the hassle of constant cleaning of calcium build-up.

Part #	Description
45157	Neutra 7 - 7 Lb. Bottle
45158	Neutra 7 - 40 Lb. Pail



Hach Test Kits



#202300



#49018



#66751



#4918370



**NEW Dealer Combination Kit –
Hardness, iron,
sulphur, pH, Manganese, TDS**

PART #	DESCRIPTION
Test Kits	
49145300	5B HARDNESS KIT - 0-30 GPG
49146700	MNS MANGANESE (0-3 MG/L) KIT
49193701	TA3 TANNIN - LIGNIN KIT
49225401	CN65 TOTAL CHLORINE KIT / 0.2 - 20
49223101	KIT,TEST,CN-66,CHLORINE,TOTAL/FREE,0.1-3.5
49018	HS-C HYDROGEN SULPHIDE KIT (0 - 5 MG/L)
49016	TEST KIT COMBINATION DEALER 2496101
202300	TEST KIT, HA-77 HARDNESS & IRON
33004	SOAP TEST KIT
491407699	CHLORINE, PP DPD TOTAL, 5 ML, 100/PK TEST STRIPS
491407799	CHLORINE, DPD FREE, 5 ML, 100/PK TEST STRIPS
49183701	HA62A HARDNESS, IRON, pH KIT
49-1464-01	KIT,TEST,IR188,IRON,0-10
Testers & Meters	
80050007	PH/TEMP WATERPROOF HYDRO TESTER, PH-80
66761	PH/TEMP METER, pH-200, 0-14 pH
66751	METER TDS MYRON L 0-5000 PPM 512M5
66760	TESTER,TDS,TDS-3,0-9990 PPM,TEMP,C/W CASE,HMDIGI
Solutions & Reagents	
4942511	SOLUTION, HARDNESS 2, 500 ML
4942616	SOLUTION, HARDNESS 3, 500 ML
49022	TABLETS, ALKASELTZER 36
4985199	PILLOW, HARDNESS INDICATOR POWDER PK/100 Manver 2
4998499	PILLOW, SODIUM PERIODATE POWDER PK/100
4998366	PILLOW, BUFFER CITRATE POWDER PK/100
301233	PILLOW, FERROUS IRON REAGENT POWDER PK/100
4985466	PILLOW, FERROVER POWDER,25ML ,PK\100
49021	PILLOW, BROMTHYMOL BLUE,POWDER PK\100
49023	PAPER, HYDROGEN SULFIDE 100
301518	UNIVER 3 POWDER PILLOWS,PK/100
301226	HARDNESS 3 TEST SOLUTION,100 ML MDB
301228	HARDNESS 2 TEST SOLUTION,100 ML MDB 42532
301227	BUFFER SOLUTION HARDNESS 3 ,100 ML MDB 42432
492107669	BUFFER CITRATE TYPE PK/100,10 ML
4921320	UNIVER 3 POWDER 28.3 GRAMS 213-20H
49008	WIDE RANGE,4 PH IND,100ML,C/W DROPPER
4921111	PHENOL RED,IND SOLN,500ML
492107769	SODIUM PERODATE 10ML PK/100
492105769	FERROVER IRON RGT PK/100, 10 ML
12098071	DPD,TOTAL CHLORINE,10 ML REAGENT,100PACK,#2105669
12098070	DPD,FREE CHLORINE, 10 ML REAGENT,100PACK,#2105569
Miscellaneous	
49014	DROPPER,CHILD RES,ASSY,PK\6
49173006	TUBE,VIEWING,/5ML MARK,
4943906	BOTTLE,SQUARE GLASS,



#49145300 hach 5b hardness test Kit 1 – 30 gpg
Trust the original Hach test kit! Simple drop count
Titration measures hardness as CaCo3(1 gpg = 17.1
mg / l). 100 tests.

Spectrum Test Kits (U.S. Only)

SPECTRUM High Quality Test
 DEMO & TEST KIT For Testing the Quality of Water

	Basic	Standard	Deluxe
Components	2403	2401	2404
Sturdy Plastic Case	X	X	X
Hardness Test	X	X	X
Iron Test		X	X
pH Test		X	X
Chlorine Test			X
TDS Test			X



Basic Kit Hardness



**Standard Kit Hardness,
Iron, pH & Chlorine**



**Deluxe Kit Hardness,
Iron, pH, Chlorine & TDS**

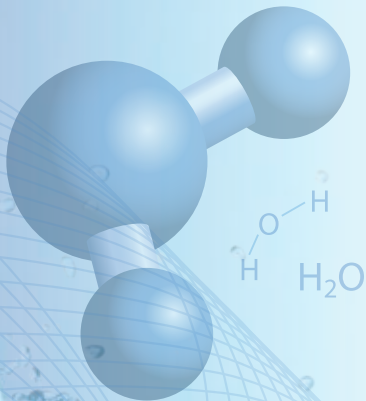

Mazzei Injectors

Mazzei® Injectors are high-efficiency, venturi-type, differential pressure injectors with internal mixing vanes. When a sufficient pressure difference exists between the inlet and outlet ports of the injector, a vacuum is created inside the injector body, which initiates suction of a liquid or gas through the suction port.

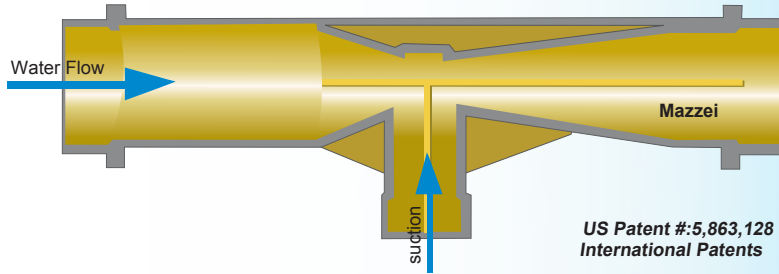

Item #	Description
80040001	Injector, Mazzei, 384-PP, ½" Inlet / Outlet
13584-484A	Injector, Mazzei, 484A-PP, ¾" Inlet / Outlet
13584-384	Injector, Mazzei, Bypass Kit 384-PP, ½" Inlet / Outlet
80040004	Injector, Mazzei, Bypass Kit 484A-PP, ¾" Inlet / Outlet

How a Mazzei® Injector Works

When pressurized water enters the injector inlet, it is constricted toward the injection chamber and changes into a high-velocity jet stream. The increase in velocity through the injection chamber results in a decrease in pressure, thereby enabling an additive material to be drawn through the suction port and entrained into the water stream. As the jet stream is diffused toward the injector outlet, its velocity is reduced and it is re-converted into pressure energy (but at a pressure lower than injector inlet pressure).

Mazzei® Injectors are extremely efficient. They operate over a wide range of pressures and require only a minimal pressure differential between the inlet and outlet sides to initiate a vacuum at the suction port.

Mattson / Witt K7225 Educator

Used for iron removal - the K7225 Educator is used in combination with an aeration tank and a backwashable filter containing special media, adds a controlled amount of air to the water supply just before it enters the aeration tank. As the water sprays into the aeration tank it picks up more air. The oxygen in the air starts the natural iron removal process by oxidizing the iron and causing it to come out of solution. The iron can then be more easily filtered.



Item #	Description
33354	Eductor PVC 1" FXF 0-15 GPM Single Port

Tubing & Fittings (John Guest Quick Connect)

Polypropylene Fittings

The PP Range of inch-size push-in fittings is offered for tube sizes 1/4" O.D. to 1/2" O.D. The fittings are manufactured in white polypropylene with food grade EPDM O-rings. They have been developed to satisfy the compatibility needs for a wide range of applications.

Working Pressures and Temperatures

Water Max. 150 psi at 70°F (Max. 10 Bar at 20°C)

Max. 60 psi at 140°F (Max. 4 Bar at 60°C)

Min. 33°F/1°C



Polypropylene Shut-Off Valve

The PPSV Range of Shut-Off Valve is offered for tube sizes 1/4" O.D. and 3/8" O.D., produced in polypropylene and fitted with EPDM O-rings. Polypropylene has the advantage of being more chemically resistant than acetal. The valves are for use with potable water. For use with other potable liquids please contact our Technical Support Department for guidance. The valves are not to be used with compressed air, explosive gases, petroleum spirits and other fuels or for heating systems.

Working Pressures and Temperatures

Water Max. 150 psi at 70°F (Max. 10 bar at 20°C)

Max. 60 psi at 140°F (Max. 4 bar at 60°C)

Min. 33°F/1°C



Polypropylene Fittings

The John Guest PE Range of plastic tubing is produced in Linear Low Density Polyethylene for cold and intermittent hot water applications. Our tubing is made from FDA compliant materials and is NSF International Standard 51 & 61 certified. John Guest LLDPE Tubing provides excellent resistance to environmental stress cracking as measured by ASTM D-1693 (10% IGEPAL). John Guest Polyethylene tubing is designed for use with John Guest Super Speedfit push-in fittings, John Guest Shut-Off Valves and virtually all standard tubing connectors.

Tubing & Fittings (John Guest Quick Connect)

Part #	Model Description
--------	-------------------

Male Connector - NPTF Thread



CI010821W	1/4" X 1/8"-WHITE, (10 Pack)
CI010822W	1/4" X 1/4"-WHITE, (10 Pack)
CI010823W	1/4" X 3/8"-WHITE, (10 Pack)
CI011222W	3/8" X 1/4"-WHITE, (10 Pack)
PI010821S	1/4" X 1/8", (10 Pack)
PI010822S	1/4" X 1/4", (10 Pack)
PI010823S	1/4" X 3/8", (10 Pack)
PI011221S	3/8" X 1/8", (10 Pack)
PI011222S	3/8" X 1/4", (10 Pack)
PI011223S	3/8" X 3/8", (10 Pack)
PI011224S	3/8" X 1/2", (10 Pack)
PI011623S	1/2" X 3/8", (10 Pack)
PI011624S	1/2" X 1/2", (10 Pack)
PI012026S	1/4" X 3/4", (10 Pack)
PP010822W	1/4" X 1/4"-WHITE, (10 Pack)
PP010823W	1/4" X 3/8"-WHITE, (10 Pack)
PP011222W	3/8" X 1/4"-WHITE, (10 Pack)
PP011223W	3/8" X 3/8", (10 Pack)
PP011224W	3/8" X 1/2", (10 Pack)
PP011623W	1/2" X 3/8", (10 Pack)
PP011624W	1/2" X 1/2", (10 Pack)

Male Connector - Flare Male Connector (tube X thread)



PI0108F4S	1/4" X 1/4", (10 Pack)
PI0112F4S	3/8" X 1/4", (10 Pack)
PI0112F6S	3/8" X 3/8", (10 Pack)
PI0112F8S	3/8" X 1/2", (10 Pack)
PI0116F8S	1/2" X 1/2", (10 Pack)

Union Tee (for use when branching of - RO faucets & tanks)



CI0208W	1/4" - WHITE, (10 Pack)
CI0212W	3/8" - WHITE, (10 Pack)
PI0208S	1/4", (10 Pack)
PI0212S	3/8", (10 Pack)
PI0216S	1/2", (10 Pack)
PP0208W	1/4", (10 Pack)
PP0212W	3/8", (10 Pack)

Reducing Tee (tube x tube x branch)



PI301208S	3/8" X 3/8" X 1/4", (10 Pack)
PI301612S	1/2" X 1/2" X 3/8", (10 Pack)
PP30121208W	3/8" X 3/8" X 1/4", (10 Pack)
PP301612W	1/2" X 1/2" X 3/8", (10 Pack)

Part #	Model Description
--------	-------------------

Union Elbow (tube)



CI0308W	1/4" - WHITE, (10 Pack)
CI0312W	3/8" - WHITE, (10 Pack)
PI0308S	1/4", (10 Pack)
PI0312S	3/8", (10 Pack)
PI0316S	1/2", (10 Pack)
PP0308W	1/4", (10 Pack)
PP0312W	3/8", (10 Pack)
PP0316W	1/2", (10 Pack)

Fixed Elbow (NPTF Thread - tube X thread)



CI480821W	1/4" X 1/8" - WHITE, (10 Pack)
CI480822W	1/4" X 1/4" - WHITE, (10 Pack)
CI480823W	1/4" X 3/8" - WHITE, (10 Pack)
CI481222W	3/8" X 1/4" - WHITE, (10 Pack)
PI480821S	1/4" X 1/8", (10 Pack)
PI480822S	1/4" X 1/4", (10 Pack)

PI480823S	1/4" X 3/8", (10 Pack)
PI481222S	3/8" X 1/4", (10 Pack)
PI481223S	3/8" X 3/8", (10 Pack)
PI482024S	5/8" X 1/2", (10 Pack)
PP480821W	1/4" X 1/8", (10 Pack)
PP480822W	1/4" X 1/4", (10 Pack)
PP480823W	1/4" X 3/8", (10 Pack)
PP481222W	3/8" X 1/4", (10 Pack)
PP481223W	3/8" X 3/8", (10 Pack)

Reducing Elbow (tube X tube)



PI211208S	3/8" X 1/4", (10 Pack)
PI211612S	1/2" X 3/8", (10 Pack)
PP211208W	3/8" X 1/4", (10 Pack)
PP211612W	1/2" X 3/8", (10 Pack)

Plug In/Stem Elbow (stem X tube)



CI220808W	1/4" X 1/4" - WHITE, (10 Pack)
CI221208W	3/8" X 1/4" - WHITE, (10 Pack)
CI221212W	3/8" X 3/8" - WHITE, (10 Pack)
PI220808S	1/4" X 1/4", (10 Pack)
PI221208S	3/8" X 1/4", (10 Pack)
PI221212S	3/8" X 3/8", (10 Pack)
PI221616S	1/2" X 1/2", (10 Pack)
PP220808W	1/4" X 1/4", (10 Pack)
PP221208W	3/8" X 1/4", (10 Pack)
PP221212W	3/8" X 3/8", (10 Pack)
PP221616W	1/2" X 1/2", (10 Pack)

Tubing & Fittings (John Guest Quick Connect)

Part #	Model Description
--------	-------------------

Union Connector (tube X tube)



CI0408W	1/4" - WHITE, (10 Pack)
CI0412W	3/8" - WHITE, (10 Pack)
PI0408S	1/4", (10 Pack)
PI0412S	3/8", (10 Pack)
PI0416S	1/2", (10 Pack)
PP0408W	1/4", (10 Pack)
PP0412W	3/8", (10 Pack)
PP0416W	1/2", (10 Pack)

Reducing Union (union X tube X tube)



PI201208S	3/8" X 1/4", (10 Pack)
PI201612S	1/2" X 3/8", (10 Pack)
PP201208W	3/8" X 1/4", (10 Pack)
PP201612W	1/2" X 3/8", (10 Pack)

Stem Adaptor (NPTF Thread - stem X thread)



CI050821W	1/4" X 1/8" - WHITE, (10 Pack)
CI050822W	1/4" X 1/4" - WHITE, (10 Pack)
CI051222W	3/8" X 1/4" - WHITE, (10 Pack)
CI051223W	3/8" X 3/8" - WHITE, (10 Pack)
PI050821S	1/4" X 1/8", (10 Pack)
PI050822S	1/4" X 1/4", (10 Pack)
PI051222S	3/8" X 1/4", (10 Pack)
PI051223S	3/8" X 3/8", (10 Pack)
PI051623S	1/2" X 3/8", (10 Pack)
PI051624S	1/2" X 1/2", (10 Pack)
PP050821W	1/4" X 1/8", (10 Pack)
PP050822W	1/4" X 1/4", (10 Pack)
PP051222W	3/8" X 1/4", (10 Pack)
PP051223W	3/8" X 3/8", (10 Pack)
PP051623W	1/2" X 3/8", (10 Pack)
PP051624W	1/2" X 1/2", (10 Pack)

Stem Reducer (stem X thread)



CI061208W	3/8" X 1/4" - WHITE, (10 Pack)
PI061208S	3/8" X 1/4", (10 Pack)
PI061612S	1/2" X 3/8", (10 Pack)
PP061208W	3/8" X 1/4", (10 Pack)
PP061612W	1/2" X 3/8", (10 Pack)

Part #	Model Description
--------	-------------------

Bulkhead Union (tube X mounting hole diameter)



CI1208W	1/4" - 0.67 - WHITE, (10 Pack)
PI1208S	1/4" - 0.67, (10 Pack)
PI1212S	3/8" - 0.83, (10 Pack)
PI1216S	1/2" - 1.06, (10 Pack)
PP1208W	1/4" - 0.67, (10 Pack)
PP1212W	3/8" - 0.83, (10 Pack)
PP1216W	1/2" - 1.06, (10 Pack)

Reducing Bulkhead Union (tube X tube X mounting hole diameter)

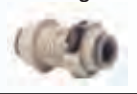

PI121208S	3/8" X 1/4" - 0.83, (10 Pack)
PP121208W	3/8" X 1/4" - 0.83, (10 Pack)

Faucet Connector UNS Thread (tube X thread)



CI3208U7S	1/4" X 7/16", (10 Pack)
CI3212U7S	3/8" X 7/16", (10 Pack)
PP3208U7W	1/4" X 7/16", (10 Pack)
PP3212U7W	3/8" X 7/16", (10 Pack)

Stem to Hose Barb (stem X hose barb)



PI250808S	1/4" X 1/4", (10 Pack)
PI251208S	3/8" X 1/4", (10 Pack)
PI251212S	3/8" X 3/8", (10 Pack)
PI251216S	3/8" X 1/2", (10 Pack)
PP251212W	3/8" X 3/8", (10 Pack)
PP251216W	3/8" X 1/2", (10 Pack)
PP251612W	1/2" X 3/8", (10 Pack)
PP251616W	1/2" X 1/2", (10 Pack)

Stem to Hose Barb Long Version (stem X hose barb)



PI251212SL	3/8" X 3/8", (10 Pack)
PI290808S	1/4" X 1/4", (10 Pack)
PI291208S	3/8" X 1/4", (10 Pack)

Female Connector NPTF Thread (tube X thread)



PI450822S	1/4" X 1/4", (10 Pack)
PI451222S	3/8" X 1/4", (10 Pack)
PP450822W	1/4" X 1/4", (10 Pack)
PP451222W	3/8" X 1/4", (10 Pack)

Tubing & Fittings (John Guest Quick Connect)

PEI202820	3/4" x 1/2" Reducing Coupler,
-----------	-------------------------------

PEX Plug-in Elbow



PEI222020	PEX Plug-In Elbow, 1/2" Stem - 1/2" Pipe,
PEI222828	PEX Plug-In Elbow, 3/4" Stem - 3/4" Pipe,

PEX Reducing Tee



PEI3028A	PEX Reducing Tee 3/4" x 3/4" x 1/2" CTS,
PEI3028B	PEX Reducing Tee 3/4" x 1/2" x 1/2" CTS,
PEI3028C	PEX Reducing Tee 1/2" x 1/2" x 3/4" CTS,
PEI3028D	PEX Reducing Tee 3/4" x 1/2" x 3/4" CTS,

PEX Stackable Tee



PEI532020	PEX Stackable Tee 1/2" CTS x 1/2" Stem x 1/2" CTS
PEI532820	PEX Stackable Tee 3/4" CTS x 3/4" Stem x 1/2" CTS
PEI532828	PEX Stackable Tee 3/4" CTS x 3/4" Stem x 3/4" CTS

PEX Miscellaneous



PEIBTC2034	PEX Female Swivel Elbow, 1/2" CTS x 1/2" NPS
PEIBTC20C75	PEX Female Ballcock Elbow, 1/2" CTS x 7/8"-15/16 UNS
PEISTC2034	PEX Female Swivel Connector, 1/2" CTS x 1/2" NPS
PEISTC20C75	PEX Female Ballcock Connector, 1/2" CTS x 7/8"-15/16 UNS







Marketing Materials

Literature Order Form

Catalog and Consumer Literature

	Item #	Description	Quantity		Item #	Description	Quantity
	80156001	Catalog			80156003	Softener Trifold (25/pack)	
	80156002	Price List (Canada)			80156004	Drinking Water Trifold (25/pack)	
	80156014	Price List (USA)			80156006	Problem Water Trifold (25/pack)	
	80156040	WaterGroup Key Dealer Info Brochure			80151027	Eco Smart Softeners (25/pack)	

Spec Sheets - Aqua Flo

	Item #	Description	Quantity		Item #	Description	Quantity
	80157000	475 Series RO (25/pack)			80157003	Platinum QCRO Series (25/pack)	
	80157001	Economy Series RO (25/pack)			80157002	Platinum 1240 Series RO (25/pack)	
	80157019	75GPD HERO RO (25/pack)			80157021	GEN 4 UV (25/pack)	
	80157015	Platinum POU Brochure (25/pack)			80157022	GEN H4 UV (25/pack)	

Marketing Materials

Literature Order Form

Spec Sheets - Aqua Flo - cont'd





	Item #	Description	Quantity		Item #	Description	Quantity
	80157005	GEN 5 UV (25/pack)			80157009	GEN 5 Rack System UV (25/pack)	
	80157006	GEN 5H UV (25/pack)			80157011	UVB Series (25/pack)	
	80157007	GEN 6 UV (25/pack)			80157012	UV20 Series (25/pack)	
	80157008	GEN H6 UV (25/pack)			80157013	UV Big Boy Series (25/pack)	
	80157020	GEN 4 Rack System UV (25/pack)			80157014	EPCB/ UV Add On Series (25/pack)	

POSTERS/BANNERS/MISC.

	Item #	Description	Quantity		Item #	Description	Quantity
	80156010	Carbon Pipe Hanger (25/pack)			80156009	WG Vinyl Banner with Grommets (2'x4') (\$20.00)	
	80156011	Water Hardness Pipe Hanger (25/pack)			80155025	WG Acrylic Brochure Stand	
	80156007	WG Sizing Guide			80160000	Showroom Display (\$195.00)	
	80156008	WaterGroup Wholesale Showroom Poster (22" x28")			95330	Water Sample Kit (Mailing Tube, Bottle & Instruction)	

Marketing Materials

Literature Order Form

KEY DEALER PROGRAM							
	Item #	Description	Quantity		Item #	Description	Quantity
	80156040	WaterGroup Key Dealer Info Brochure			80156044	WG Key Dealer Vehicle Decal	
	80151039	Help Line Sticker WG			80156045	WG Key Dealer Homeshow Banner	
	80156042	Key Dealer Shirt Decal			80156046	WG Key Dealer Showroom Poster	
	80156043	WG Key Dealer Window Static Cling Decal					

WaterGroup LITERATURE ORDER FORM

Fill Out Order Form & Email To:

Canadian Orders: orderscanada@canaturewg.com

US Orders: ordersusa@canaturewg.com

Company Name: _____ **Customer Number:** _____

Contact Name: _____ **City, Province/ State:** _____

Mailing Address: _____ **Postal Code/ Zip:** _____

Telephone #: _____ **Fax #:** _____

Email Address: _____ **Sales Representative:** _____

A Division of



Commercial Systems

Industry Leading Support From Start To Finish

Canature WaterGroup™ Application Engineering Staff are ready to assist you in preparing a design package for the water treatment equipment you need.

Canature WaterGroup™ has dedicated Professional Engineers with decades of commercial water treatment experience to compliment our knowledgeable field sales team. Together they provide complete support starting from the water analysis, sizing, and selection right through to the installation.

Our **High-Efficiency Water Treatment Designs** provide Lower Capital and Operating Costs offering your clients **Exceptional ROI!**

Industry Leading Support From Start to Finish

- Water Analysis
- System Selection & Sizing
- Professional Drawings and Specifications
- Installation Support

Complete line of Commercial Water Treatment Products

- High-Efficiency Water Softeners & Filters
- Dealkalizers
- Membrane Technologies
- Ultraviolet Sterilizers
- Engineered Systems

The commercial market is full of opportunities for you to add valuable revenues

- Laundromats
- Carwashes
- Restaurants
- Hospitals
- Schools
- Hotels
- Office Buildings
- Manufacturing Facilities



 **Canature™**
WaterGroup
Commercial/Industrial Engineering Division

Visit our website @
www.canaturewg-cied.com



Water Conditioning Glossary

Absorption - The process in which one substance is taken into the body of another substance, termed the absorbent. An example is the absorption of water into soil.

Acid - A substance which releases hydrogen ions when dissolved in water. Most acids will dissolve the common metals and will react with a base to form a neutral salt and water.

Activated Carbon - A granular material usually produced by the roasting of cellulose base substances, such as wood or coconut shells, in the absence of air. It has a very porous structure and is used in water conditioning as an adsorbent of organic matter and certain dissolved gases. Sometimes called "activated charcoal."

Adsorption - The process in which matter adheres to the surface of the adsorbent.

Aeration - The process in which air is brought into intimate contact with water, often by spraying water through air or by bubbling air through water. Aeration may be used to add oxygen to the water for oxidation of matter such as iron or to cause the release of dissolved gases such as carbon dioxide or hydrogen sulfide from the water.

Alkalinity - The quantitative capacity of a water or water solution to neutralize an acid. It is usually measured by titration with a standard acid solution of sulfuric acid and expressed in terms of its calcium carbonate equivalent.

Anion - A negatively charged ion in solution such as bicarbonate, chloride or sulfate.

Anion Exchange - An ion exchange process in which anions in solution are exchanged for other anions from an ion exchanger. In demineralization, for example, bicarbonate, chloride and sulfate anions are removed from solution in exchange for a chemically equivalent number of hydroxide anions from the anion exchange resin.

Aquifer - A layer or zone below the surface of the earth which is capable of yielding a significant volume of water.

Atom - The smallest particle of an element that can exist either alone or in combination with smaller particles of the same element or of a different element.

Attrition - The process in which solids are worn down or ground down by friction, often between particles of the same material. Filter media and ion exchange materials are subject to attrition during backwashing, regeneration and service.

Backwash - The process in which beds of filter or ion exchange media are subjected to flow opposite to service flow direction to loosen the bed and to flush suspended matter collected during the service run to waste.

Bacteria - Unicellular micro-organisms which typically reproduce by cell division. Although usually classed as plants, bacteria contain no chlorophyll.

Bacteriostatic - A feature of a carbon filter that is supposed to inhibit the growth of bacteria within the filter - usually by the addition of silver.

Base - A substance which releases hydroxyl ions when dissolved in water. Bases react with acids to form a neutral salt and water.

Bed - The ion exchange or filter media in a column or other tank or operational vessel.

Bed Depth - The height of the ion exchange or filter

media in the vessel after preparation for service.

Boiling Point - The temperature at which a substance will change from a liquid state to a gaseous or vapor state.

Brackish Water - Water containing between 1000 and 1500 mg/l of dissolved solids is generally considered to be brackish.

Brine (R.O.) - Same as reject water. One of two streams of fluids generated by a reverse osmosis unit. It contains the impurities removed from the feed water.

Brine (Softening) - A strong solution of salt(s), such as sodium chloride, and water used in the regeneration of ion exchange water softeners but also applied to the mixed sodium, calcium and magnesium chloride waste solution from regeneration.

Calcium (Ca) - One of the principal elements making up the earth's crust, the compounds of which, when dissolved, make the water hard. The presence of calcium in water is a factor contributing to the formation of scale and insoluble soap curds which are a means of clearly identifying hard water.

Calcium Hypochlorite (CaCl₂O₂) - A chemical compound used as a bleach and a source of chlorine water treatment; specifically useful because it is stable as a dry powder and can be formed into tablets.

Capacity - An expression of the quantity of an undesirable material which can be removed by a water conditioner between servicing of the media (i.e. cleaning, regeneration or replacement) as determined under standard test conditions. For ion exchange water softeners, the capacity is expressed in grains of hardness removal between successive regenerations and is related to the pounds of salt used in regeneration. For filters, the capacity may be expressed in the length of time or total gallons delivered between servicing.

Caustic Soda - The common name for sodium hydroxide.

Cation - An ion with a positive electrical charge, such as calcium, magnesium and sodium.

Cation Exchange - Ion exchange process in which cations in solution are exchanged for other cations from an ion exchanger.

Cellulose Acetate (CA) and Cellulose Triacetate (CTA) - A family of synthetic materials based on cellulose used to make reverse osmosis membranes. While CTA is superior to CA, under adverse water conditions both are effective in removing a wide spectrum of impurities from water. The disadvantage of cellulose-type membranes is that they are subject to bacterial attack, particularly in unchlorinated water supplies. CTA has superior bacterial resistance.

Channeling - The flow of water or other solution in a limited number of passages in a filter or ion exchange bed instead of distributed flow through all passages in the bed.

Chloramines - Chemical complexes formed from the reaction between ammonia and chlorine. They are presently being used to disinfect municipal water supplies because, unlike chlorine, they do not combine with organics in the water to form potentially dangerous carcinogens such as trihalomethanes (THMs). Chloramines can exist in three forms, the proportions of which depend on the physical and chemical properties of the water. Water containing chloramines may not be used for fish or kidney dialysis equipment.

Chlorides (Cl) - an ion which forms acids when combined with hydrogen and salts when combined with metal ions.

Chlorides can be corrosive and impart a salty taste to water.

Chlorine (Cl₂) - A gas widely used in the disinfection of water and an oxidizing agent for organic matter, iron, etc.

Coagulant - A material, such as alum, which will form a gelatinous precipitate in water and cause the agglomeration of finely divided particles into larger particles which can then be removed by settling and/or filtration.

Colloid - Very finely divided solid particles which will not settle out of a solution; intermediate between a true dissolved particle and a suspended solid which will settle out of solution. The removal of colloidal particles usually requires coagulation to form larger particles which may be removed by sedimentation and/or filtration.

Compensated Hardness - A calculated value based on the total hardness - the magnesium to calcium ratio and the sodium concentration of a water. It is used to correct for the reductions in hardness removal capacity caused by these factors in cation exchange water softeners. No single method of calculation has been widely accepted.

Conductivity - The quality or power to carry electrical current. In water, the conductivity is related to the concentration of ions capable of carrying electrical current.

Contact Time - The length of time water is in direct contact with activated carbon (R.O.) or chlorine (chlorination system.) This is a major factor in determining how effectively impurities will be removed.

Corrosion - The destructive disintegration of a metal by electrochemical means.

Cycle Time - The amount of time in seconds elapsed between pump start and pump shut-down.

Dechlorination - The removal of excess chlorine residual, often after super-chlorination.

Deionization (DI) - The removal of all ionized minerals and salts (both organic and inorganic) from a solution by a two-phase ion exchange procedure. First, positively charged ions are exchanged for a chemically equivalent amount of hydrogen ions. Second, negatively charged ions are removed by an ion exchange resin for a chemically equivalent amount of hydrogen ions. The hydrogen and hydroxide ions introduced in this process unite to form water molecules. The term is often used interchangeably with demineralization.

Disinfection - A process in which pathogenic, disease producing bacteria are killed. May involve disinfecting agents such as chlorine or physical processes such as heating.

Dissolved Solids - The weight of matter in true solution in a stated volume of water. Includes both inorganic and organic matter and is usually determined by weighing the residue after evaporation of the water at 105°F or 180°C.

Distillation - The process in which a liquid, such as water, is converted into its vapor state by heating and the vapor cooled and condensed to the liquid state and collected. Used to remove solids and other impurities from water. Multiple distillations are required for extreme purity.

DNA - Deoxyribonucleic acid constituting the genetic material of the chromosome in a cell, responsible for reproductive characteristics.

Drawdown - The amount of water delivered by the storage tank between pump shut-down and pump start.

E Coli (Escherichia Coli) - One of the members of the coliform group of bacteria indicating fecal contamination.

Effluent - The stream emerging from a unit, system or process such as the softened water from an ion exchange softener.

Exhaustion - The state of an ion exchange material in which it is no longer capable of effective function due to the depletion of the initial supply of exchangeable ions. The exhaustion point may be defined in terms of a limiting concentration of matter in the effluent or, in the case of demineralization, in terms of electrical conductivity.

Fecal - Matter containing or derived from animal or human waste.

Feed Pressure - The pressure at which water is supplied to the R.O. module.

Feed Water - A term which refers to the water supply that is put into a water treatment system for processing (removal of impurities.)

Flocculation - The agglomeration of finely divided suspended solids into larger, usually gelatinous, particles. The development of a 'floc' after treatment with a coagulant by gentle stirring or mixing.

Flow Control - A device designed to limit the flow of water or regenerant to a predetermined value over a broad range of inlet water pressures.

Flow Rate - The quantity of water or regenerant which passes a given point in a specified unit of time, often expressed in gallons per minute.

Flux - The flow rate of water through reverse osmosis membranes, per square foot of surface.

Fouling - The process in which undesirable foreign matter accumulates in a bed of filter media or ion exchanger, clogging pores and coating surfaces and thus inhibiting or retarding the proper operation of the bed.

Freeboard - The vertical distance between a bed of filter media or ion exchange material and the overflow or collector for backwash water. The height above the bed of granular media available for bed expansion during backwashing. May be expressed either as a linear distance or a percentage of bed depth.

Grain (gr) - A unit of weight equal to 1/7000 of a pound or 0.0648 gram.

Grain per Gallon (gpg) - A common basis for reporting water analysis in the United States and Canada. One grain per U.S. gallon equals 17.12 milligrams per liter (mg/l) or parts per million (ppm). One grain per British (Imperial) gallon equals 14.3 mg/l or ppm.

Greensand - A natural mineral, primarily composed of complex silicates, which can be coated with manganese oxide to form a catalytic absorptive surface. This surface is used to attract ferrous iron and manganese as well as to absorb dissolved oxygen which is used to oxidize iron, manganese or hydrogen sulfide.

Hardness - A characteristic of natural water due to the presence of dissolved calcium and magnesium. Water hardness is responsible for most scale formation in pipes and water heaters and forms insoluble "curd" when it reacts with soaps. Hardness is usually expressed in grains per gallon (gpg), parts per million (ppm) or milligrams per liter (mg/l), all as calcium carbonate equivalent.

Water Conditioning Glossary

Hard Water - Water with a total hardness of 1 gpg or more as calcium carbonate equivalent.

Hydrologic Cycle - The natural water cycle, including precipitation of water from the atmosphere as rain or snow, flow of water over or through the earth and evaporation or transpiration to water vapor in the atmosphere.

Hydrogen Sulfide (H₂S) - A gas characterized by an offensive odor, commonly referred to as "rotten egg" odor. Flammable and poisonous in high concentrations, corrosive to most metals and can even tarnish silver. Detectable by most people in concentrations as low as 0.5 ppm.

Hydrocharger - Trade name of a particular type of air induction or injector valve.

Hydrolysis - The chemical degradation of an R.O. membrane in water due to certain conditions such as high pH. Cellulose based membranes are quite susceptible to hydrolysis while the TFC type are virtually immune.

Influent - The stream entering a unit, stream or process, such as the hard water entering an ion exchange water softener.

Ion - An atom, or group of atoms, which function as a unit and have a positive or negative electrical charge due to the gain or loss of one or more electrons.

Ion Exchange - A reversible process in which ions are released from an insoluble permanent material in exchange for other ions in a surrounding solution; the direction of the exchange depends upon the affinities of the ion exchanger for the ions present and the concentrations of the ions in the solution.

Iron (Fe) - An element often found dissolved in ground water (in the form of ferrous iron) in concentrations usually ranging from 0-10 ppm (mg/l). It is objectionable in water supplies because of the staining caused after oxidation and precipitation (as ferric hydroxide); because of the tastes; and because of unsightly colors produced when iron reacts with tannins in beverages such as coffee and tea.

Iron Bacteria - Organisms which are capable of utilizing ferrous iron, either from the water or from steel pipe in their metabolism and precipitating ferric hydroxide in their sheaths and gelatinous deposits. These organisms tend to collect in pipelines and tanks during periods of low flow and to break loose in slugs of turbid water to create staining, taste and odor problems.

Magnesium (Mg) - One of the elements making up the earth's crust, the compounds of which, when dissolved in water, make the water hard. The presence of magnesium in water is a factor contributing to the formation of scale and insoluble soap curds.

Manganese (Mn) - An element sometimes found dissolved in ground water, usually with dissolved iron but in lower concentrations. Causes black stains and other problems similar to iron.

Manganese Greensand - Greensand which has been processed to incorporate in its pores and on its surface the higher oxides of manganese. The product has a mild oxidizing power and is often used in the oxidation and precipitation of iron, manganese and/or hydrogen sulfide and their removal from water.

Mechanical Filtration - The process of removing suspended particles from water by a straining action. The finest mechanical filters can remove bacteria as small as 0.2 microns.

Media - The selected materials in a filter that form the barrier to the passage of certain suspended solids or dissolved minerals. (Singular of media is medium).

Milligrams per Liter (mg/l) - A unit concentration of matter used in reporting the results of water and wastewater analysis. In dilute water solutions, it is practically equal to parts per million but varies from the ppm in concentrated solutions such as brine. As most analysis are performed on measured volumes of water, the mg/l is a more accurate expression of the concentration and is the preferred unit of measure.

Micron - A linear measure equal to one millionth of a meter or .00003937 inch. The symbol for the micron is the Greek letter "μ".

Micron Rating - The term applied to a filter or filter medium to indicate the particle size above which all suspended solids will be removed throughout the rated capacity. As used in industry standards, this is an "absolute" not "nominal" rating. (Refer to S-200, Recommended Industry Standards for Household & Commercial Water Filters.)

Mineral - A term applied to inorganic substances such as rocks and similar matter found in the earth strata as opposed to organic substances such as plant and animal matter. Minerals normally have definite chemical composition and crystal structure. The term is also applied to matter derived from minerals such as the inorganic ions found in water. The term has been incorrectly applied to ion exchangers, even though most of the modern materials are organic ion exchange resins.

Mineral Salts - The form in which minerals from dissolved rock exist in water. Same as Total Dissolved Solids. This is the so-called inorganic form of minerals. In excess, they cause water to have a disagreeable taste. Some are harmful to human health.

Molecular Weight - The sum of the atomic weights of the individual atoms (from a periodic chart) that make up a molecule of a particular substance (e.g. H₂O) H=1 atomic weight, O=16 atomic weight, therefore, molecular weight = 2 + 16 = 18.) Cellulose based membranes can remove substances as light as MW of 300, while TFC type membranes remove substances as light as MW of 200.

Nanometer - A measure of a wavelength in the electromagnetic spectrum. One nanometer equals 109 meter.

Neutralization - In general, the addition of either an acid or a base to a solution as required to produce a neutral solution. The use of alkaline or basic materials to neutralize the acidity of some waters is common practice in water conditioning.

Organic Iron - A ferrous iron molecule which is enveloped in an organically complex molecule that resists oxidation. May be present in water that contains a great deal of colored colloidal turbidity.

Organics - Any of the compounds whose chemical structure is based on carbon (e.g. carbon dioxide, wood, sugar, protein, plastics, methane, THM, TCE, etc.)

Osmosis - A process of diffusion of a solvent, such as water through a semipermeable membrane, which will transmit the solvent but impede most dissolved substances. The normal flow of solvent is from the dilute solution to the concentrated solution. (See Reverse Osmosis).

Osmotic Pressure - The pressure created by the tendency of water to flow in osmosis. Every 100 ppm of TDS generates about 1 pound per square inch (psi) of osmotic pressure. This osmotic pressure must first be overcome by the water pressure for the reverse osmosis membrane to be effective.

Water Conditioning Glossary

Oxidation - A chemical process in which electrons are removed from an atom, ion or compound. The addition of oxygen is a specific form of oxidation. Combustion is an extremely rapid form of oxidation while the rusting of iron is a slow form.

Oxidizing Agents - Any substance that oxidizes another substance and is itself reduced in the process. Common examples include: oxygen, chlorine, potassium permanganate, hydrogen peroxide, iodine and ozone.

Ozone (O₃) - An unstable form of oxygen occurring naturally in the upper atmosphere or artificially produced because of its strong oxidizing or disinfection characteristics.

Particle Size - As used in industry standards, the size of a particle suspended in water as determined by its smallest dimension, usually expressed in microns.

Parts per Million (ppm) - A common basis for reporting the results of water and waste water analysis, indicating the number of parts by weight of water or other solvent. In dilute water solutions, one part per million is practically equal to one milligram per liter, which is the preferred unit. 17.12 ppm equals one grain per U.S. gallon.

Pathogen - An organism which may cause disease.

PCB - Polychlorinated Biphenyls - A highly toxic organic contaminant found in water supplies which is suspected of causing cancer in humans.

pH - or the potential of hydrogen ion activity or concentration. pH is a measure of the intensity of the acidity or alkalinity of water on a scale from 0 to 14, with 7 being neutral. When acidity is increased, the hydrogen ion concentration increases, resulting in a lower pH value. Similarly, when alkalinity is increased, the hydrogen ion concentration decreases, resulting in higher pH. The pH value is an exponential function so that pH is 10 times as alkaline as pH 9 and 100 times as alkaline as pH 8. Similarly, a pH 4 is 100 times as acid as pH 6 and 1000 times as acid as pH 7.

Potassium Chloride (KCl) - a compound consisting of potassium and chloride, becoming increasingly popular as a substitute for sodium chloride in regenerating water softeners.

Potassium Permanganate (KMnO₄) - A powerful oxidizing agent consisting of dark purple crystals with blue metallic sheen. Explosive in contact with sulfuric acid or hydrogen peroxide. Increases flammability of combustible materials. Used to renew the black manganese oxide coating on greensand media.

Precipitate - To cause a dissolved substance to form a solid particle which can be removed by settling or filtering such as in the removal of dissolved iron by oxidation, precipitation and filtration. The term is also used to refer to the solid formed and the condensation of water in the atmosphere to form rain or snow.

Pre-treatment - Whatever alterations of the raw feed water are required to prevent damage to the reverse osmosis membrane.

Product Water - The pure water that has been separated from the feed water stream by the reverse osmosis membrane.

Pumping Rate - The amount of actual water that can be drawn from a pressure system expressed in gallons per minute (gpm) obtained by dividing the drawdown (gallons) by the cycle time (seconds) and multiplying the result by 60 (seconds.)

Quartz - A high grade of glass made using quartz sand.

Raw Water - Untreated water or any water before it reaches a specific water treatment device or process.

Recovery - The amount of product water as compared with the total amount of feed water. This will give a measure of the efficiency of operation. For example, starting with 10 gallons of feed water, if 6 gallons is product water and 4 gallons reject water, the recovery is 60%.

Regenerant - A solution of a chemical used to restore the capacity of an ion exchange or oxidation system.

Regeneration - In general, includes the backwash, brine and fresh water rinse steps necessary to prepare a water softener exchange bed for service after exhaustion. Specifically, the term may be applied to the "brine" step in which the sodium chloride solution is passed through the exchanger bed. The term may also be used for similar operations relating to demineralizers and certain filters.

Rejection - The percentage of TDS removed from the feed water. Typically greater than 90% rejection is achieved with reverse osmosis.

Reject Water (same as Brine) - That portion of the feed water that does not pass through the R.O. membrane and which carries the remaining impurities to the drain.

Residual Chlorine - Chlorine remaining in a treated water after a specified period of contact time to provide protection throughout a distribution system. The difference between the total chlorine added and that consumed by oxidizable matter.

Resin - Synthetic organic ion exchange material such as the high capacity cation exchange resin widely used in water softeners.

Reverse Osmosis (R.O.) - A process that reverses, by the application of pressure, the flow of water in the natural process of osmosis so that the water passes from the more concentrated to the more dilute solution through a semi-permeable membrane.

Sediment - The sum of particles of dirt, clay, silt and vegetation which float or are suspended in water and can be removed by mechanical filtration. See Turbidity.

Semi-permeable - A term which applies to special materials, both natural and synthetic, which allow certain substances such as water to pass through (to permeate) while blocking or rejecting the passage of other substances such as dissolved solids and organics.

Service (Peak) Flow Rate - The greatest amount of water (expressed in gallons per minute) that a particular filter can effectively process based on short pump runs of less than 10 to 15 minutes maximum.

Sequester - A chemical reaction in which certain ions are bound into a stable, water soluble compound, thus preventing undesirable action by the ions.

Soap - One of a class of chemical compounds which possesses cleaning properties, formed by the reaction of a fatty acid with a base of alkali. Sodium and potassium soaps are soluble and useful but can be converted to insoluble calcium and magnesium soaps (curd) by the presence of these hardness ions in water.

Soda Ash - The common name for sodium carbonate, a chemical compound used as an alkaline builder in some soap and detergent formulations to neutralize acid water and in the lime soda ash water conditioning process.

Total Hardness - The sum of all hardness constituents in a water, expressed as their equivalent concentration of calcium carbonate. Primarily due to calcium and magnesium in solution but may include small amounts of metals, such as iron, which can act like calcium and magnesium in certain reactions (see Hardness.)

Toxic - Having an adverse physiological effect on man.

Water Conditioning Glossary

Toxic Metals - Elemental metals that find their way into water supplies from natural and industrial sources and which are detrimental to human health (e.g. lead, cadmium, mercury, arsenic.)

Toxic Organics - Carbon-based chemicals which are frequently found in our water supplies and are harmful to human health. They are usually from agricultural and industrial effluents and hazardous waste dumps (e.g. TCE, PCB, DCBP, pesticides, etc.)

Turbidity - Suspended biological, inorganic and organic particles in water which may be in sufficient amount to make the water seem cloudy (see Sediment.)

Virus - The smallest form of life known to be capable of producing disease of infection, usually considered to be of large molecular size. They multiply by assembly of component fragments in living cells, rather than by cell division as do most bacteria.

Volatile Organic Chemical (VOC) - Chemicals or compounds with boiling points below 212°F, facilitating their evaporation before water.

Water Softening - The removal of calcium and magnesium, the ions which are the principal cause of hardness, from water.

Notes

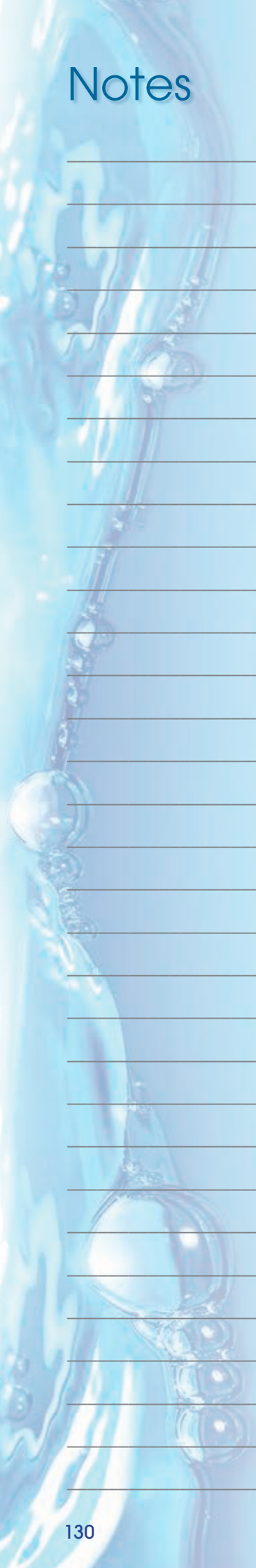

WaterGroup®

U.S.A.
9760 Mayflower Park Dr.
Suite 110, Carmel, IN 46032



U.S.A.
56 Lightcap Rd.
Pottstown, PA 19464



U.S.A.
4645 W. McDowell Rd.
Suite 106 Phoenix, AZ 85035



Canada West
855 Park St., Unit 1
Regina, SK S4N 6M1



Canada East
490 Pinebush Rd. Unit 1
Cambridge ON N1T 0A5



CALL US TOLL-FREE
1-877-288-9888

www.watergroup.com

Regina, SK • Cambridge, ON • Carmel, IN • Pottstown, PA • Phoenix, AZ

A Division of

