

## For Residential Applications

Job Name \_\_\_\_\_

Contractor \_\_\_\_\_

Job Location \_\_\_\_\_

Approval \_\_\_\_\_

Engineer \_\_\_\_\_

Contractor's P.O. No. \_\_\_\_\_

Approval \_\_\_\_\_

Representative \_\_\_\_\_

# LEAD FREE\*

## WATTS® pure water

### Model PWDWHCL1 Single-Stage Lead Filtration System

#### High Capacity, Kwik-Change™ Filter

It's well known that aging municipal supply lines and household plumbing are potential sources of lead.

Exposure to lead is especially harmful to young children and can adversely affect both their development and behavior. Watts has made it easy to provide safer drinking water.

This Watts Pure Water PWDWHCL1 Single-Stage Lead filtration system provides protection from Lead & other contaminants and connects directly to the cold side of most standard kitchen and bathroom faucets. It provides superior filtration for all the cold water to your faucet.

The one-year or 7,900 gallon filtration capacity is up to four times the capacity of other competitive filter systems. It features a high flow 0.5 micron carbon fiber filter, simple quarter turn filter change out and simple under sink installation. This Lead Filtration system is designed and certified to reduce 99.2% of lead in drinking water at any point of use in your household. It also is certified to reduce Parasitic Cyst, Chlorine taste odors and sediment for great-tasting, safer potable water.

#### Features

- High-flow system (2 gallons per minute)
- High capacity 0.5 micron carbon fiber filter (7900 gallons) for less frequent filter changes
- System comes complete with fittings & tubing required for a quick and easy standard installation
- Connects directly to most standard kitchen and bathroom cold water faucets
- High capacity filter disconnects and connects from the unit by a simple quarter-turn

#### Benefits

- Certified to reduce Lead, Cysts, Chlorine Taste Odors and Sediment
- Provides superior filtration for all the cold water to your kitchen and bathroom faucets
- No additional hole to drill for faucet in sink or counter-top
- System goes well beyond basic water filtration and typical "pitcher or "end-of-tap" filter

\*The wetted surface of this product contacted by consumable water contains less than 0.25% of lead by weight.



PWDWHCL1



PWDWHCL1 tested and certified by IAPMO R&T Lab and IAPMO R&T to meet NSF/ANSI 42 standards for the reduction of Chlorine, Taste and Odor, and Class I Particulates; NSF/ANSI 53 for the reduction of Lead and Cyst; and NSF/ANSI 372 for low lead compliance as verified and substantiated by test data.

#### ⚠ WARNING

Do not use with water that is microbiologically unsafe or of unknown quality without adequate disinfection before or after the system.

#### NOTICE

The information contained herein is not intended to replace the full product installation and safety information available or the experience of a trained product installer. You are required to thoroughly read all installation instructions and product safety information before beginning the installation of this product.

Watts product specifications in U.S. customary units and metric are approximate and are provided for reference only. For precise measurements, please contact Watts Technical Service. Watts reserves the right to change or modify product design, construction, specifications, or materials without prior notice and without incurring any obligation to make such changes and modifications on Watts products previously or subsequently sold.

# WATTS®

## Certified Performance

Tested	Average % Reduction
Lead pH 6.5	>99.7%
Lead pH 8.6	>99.2%
Cyst	99.99%
Chlorine	>94.8%
Class I Particulates	99.2%

See manual for full performance data sheet

## Specifications

PWDWHCL1 Lead Reduction System can only be installed on a cold water line. All parts required for a typical kitchen or bathroom faucet connection are included. This 2 GPM high flow system is certified to reduce lead, cysts, chlorine, odor, sand, silt, dirt and rust. The included 7,900 gallon capacity lead-reduction filter features a Kwik-Change™ quarter-turn connection for easy cartridge replacement.

## Replacement Filter Cartridge

MODEL	ORDERING CODE	FREQUENCY	DESCRIPTION
PWCFHCL1	7100576	7,900 gallons or 12 months	Carbon Fiber Filter

### NOTICE

Your water conditions may require more frequent replacement. Please contact Watts Technical Support for further assistance.

## Feed Water Requirements

Please review operating pressures, temperatures and water chemistry limitations to ensure compatibility.

	Maximum	Minimum
Operating Temperature:	100°F (37.8°C)	35° F (1.7°C)
Operating Pressure:	125psi (862 kPa)	10psi (69 kPa)
pH Parameters:	10	5
Flow Rate:	2.0 gpm	

## Dimensions

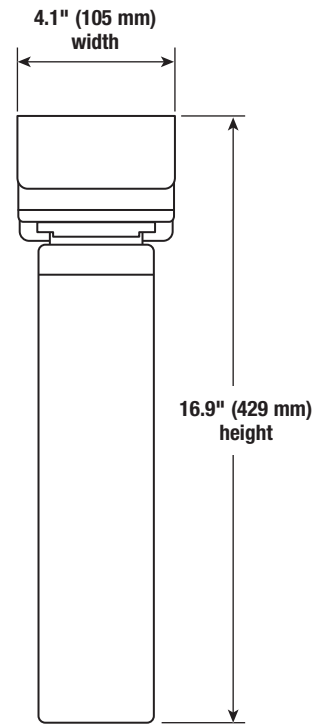

USA: T: (800) 224-1299 • F: (978) 794-1848 • [Watts.com/PureWater](http://Watts.com/PureWater)  
 Canada: T: (905) 332-4090 • F: (905) 332-7068 • [Watts.ca/PureWater](http://Watts.ca/PureWater)  
 Latin America: T: (52) 81-1001-8600 • [Watts.com/PureWater](http://Watts.com/PureWater)