



INSTALLATION INSTRUCTIONS

16 SEER

Split System Air Conditioner & Heat Pump

1.5-5 Tons

R410A

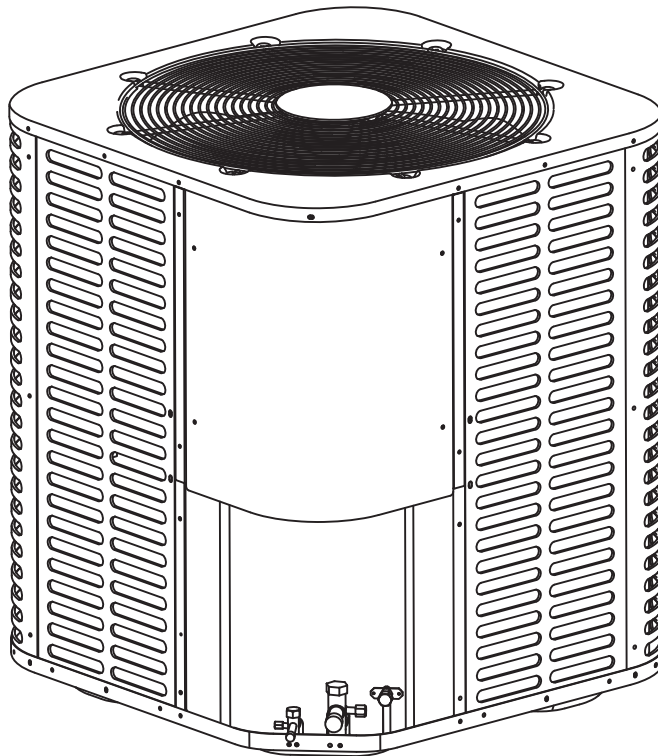

NOTE : Appearance of unit may vary.



RECOGNIZE THIS SYMBOL AS AN INDICATION OF IMPORTANT SAFETY INFORMATION

WARNING

These instructions are intended as an aid to qualified licensed service personnel for proper installation, adjustment and operation of this unit. Read these instructions thoroughly before attempting installation or operation. Failure to follow these instructions may result in improper installation, adjustment, service or maintenance possibly resulting in fire, electrical shock, property damage, personal injury or death.



DO NOT DESTROY THIS MANUAL

Please read carefully and keep in a safe place for future reference by a serviceman.

TABLE OF CONTENTS

1. KEY TO SYMBOLS AND SAFETY INSTRUCTIONS.....	1
2. UNIT LOCATION CONSIDERATIONS.....	2
3. UNIT PREPARATION.....	3
4. SETTING UP THE UNIT.....	3
5. REFRIGERANT LINE CONSIDERATIONS.....	4
6. REFRIGERANT LINE ROUTING.....	5
7. REFRIGERANT LINE BRAZING.....	7
8. REFRIGERANT LINE LEAK CHECK.....	8
9. EVACUATION.....	8
10. SERVICE VALVE.....	8
11. ELECTRICAL - LOW VOLTAGE.....	9
12. ELECTRICAL - HIGH VOLTAGE.....	10
13. START UP.....	10
14. SYSTEM CHARGE ADJUSTMENT.....	11
15. SYSTEM OPERATION AND TROUBLESHOOTING.....	16
16. WARRANTY.....	19
17. WIRING DIAGRAMS.....	20
18. MATCHING TABLE AND CHECKOUT PROCEDURES.....	23

All phases of this installation must comply with NATIONAL, STATE, AND LOCAL CODES.

1. Key to symbols and safety instructions

1.1 Key to symbols



Warnings in this document are identified by a warning triangle. Keywords at the start of a warning indicate the type and seriousness of the ensuing risk if measures to prevent the risk are not taken.



This symbol indicates important information where there is no risk to people or property.

The following keywords are defined and can be used in this document:

DANGER indicates a hazardous situation which, if not avoided, will result in death or serious injury.

WARNING indicates a hazardous situation which, if not avoided, could result in death or serious injury.

CAUTION indicates a hazardous situation which, if not avoided, could result in minor to moderate injury.

NOTICE is used to address practices not related to personal injury.

1.2 Safety

	CAUTION:
<ul style="list-style-type: none">● This document is customer property and is to remain with this unit. Please return to service information pack upon completion of work.● These instructions do not cover all variations in systems or provide for every possible contingency to be met in connection with the installation.● Should further information be desired or should particular problems arise which are not covered sufficiently for the purchaser's purposes, the matter should be referred to your installing dealer or local distributor.	

This document contains a wiring diagram and service information.

	CAUTION:
This information is intended for use by individuals possessing adequate backgrounds of electrical and mechanical experience. Any attempt to repair a central air conditioning product may result in personal injury and/or property damage.	

	WARNING: HAZARDOUS VOLTAGE
<ul style="list-style-type: none">● Failure to follow this warning could result in property damage, severe personal injury or death.● Disconnect all electric power, including remote disconnects before servicing. Follow proper lockout/tagout procedures to ensure the power cannot be inadvertently energized.	

	WARNING: REFRIGERANT OIL
These units use R-410A refrigerant which operates at 50% to 70% higher pressures than R-22. Use only R-410A approved service equipments. Refrigerant cylinders are painted a "Rose" color to indicate the type of refrigerant and may contain a "dip" tube to allow for charging of liquid refrigerant into the system. All R-410A systems use a POE oil that readily absorbs moisture from the atmosphere. To limit this "hygroscopic" action, the system should remain sealed whenever possible. If a system has been opening to the atmosphere for more than 4 hours, the compressor oil must be replaced. Never break a vacuum with air and always change the driers when opening the system for component replacement.	

	CAUTION: HOT SURFACE
May cause minor to severe burning. Failure to follow this Caution could result in property damage or personal injury. Do not touch the top of compressor.	

	CAUTION: CONTAINS REFRIGERANT
Failure to follow proper procedures can result in personal illness or injury or severe equipment damage. System contains oil and refrigerant under high pressure. Recover refrigerant to relieve pressure before opening system.	

	CAUTION: GROUNDING REQUIRED
Failure to inspect or use proper service tools may result in equipment damage or personal injury. Reconnect all grounding devices. All parts of this product that are capable of conducting electrical current are grounded. If grounding wires, screws, straps, clips, nuts or washers used to complete a path to ground are removed for service, they must be returned to their original position and properly fastened.	

	WARNING: SERVICE VALVES
Failure to follow this warning will result in abrupt release of system charge and may result in personal injury and/or property damage. Extreme caution should be exercised when opening the Liquid Line Service Valve. Turn valve stem counterclockwise only until the stem contacts the rolled edge. No torque is required.	

	WARNING: BRAZING REQUIRED
Failure to inspect lines or use proper service tools may result in equipment damage or personal injury. All outdoor unit and evaporator coil connections are copper-to-copper and should be brazed with a phosphorous-copper alloy material such as Silfos-5 or equivalent. Do not use soft solder.	

! WARNING: HIGH CURRENT LEAKAGE

Failure to follow this warning could result in property damage, severe personal injury or death. Grounding is essential before connecting electrical supply.

2. Unit location considerations

2.1 Unit dimensions

Unit Dimensions				
Model		H(Inchs)	W(Inchs)	L(Inchs)
AC	HP			
18	18/24	24-15/16	23-5/8	23-5/8
24	30	24-15/16	28	28
30	36	24-15/16	29-1/8	29-1/8
/	42	33-3/16	28	28
36/42/48/60	48/60	33-3/16	29-1/8	29-1/8

Table 1

The unit's weight value is on the cardboard box.

When mounting the outdoor unit on a roof, be sure the roof will support the unit's weight. Properly selected isolation is recommended to prevent sound or vibration transmission to the building structure.

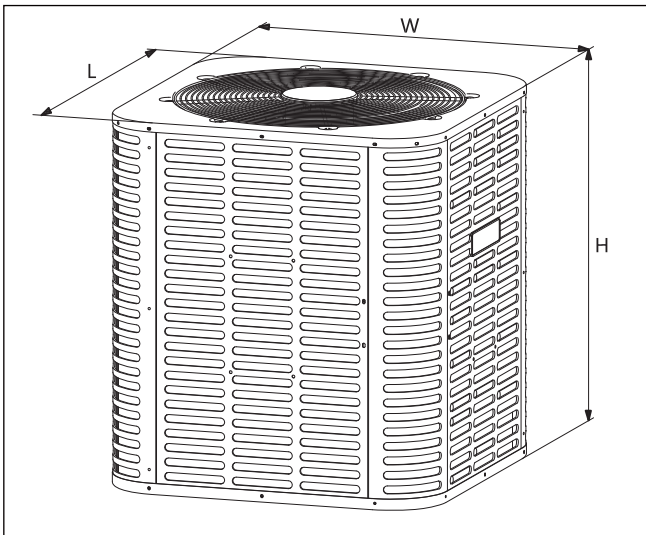

Figure 1

2.2 Location restrictions

Ensure the top discharge area is unrestricted for at least 60 inches above the unit.

Do not locate outdoor unit near bedrooms since normal operational sounds may be objectionable.

Position unit to allow adequate space for unobstructed airflow, wiring, refrigerant lines, and serviceability.

Maintain a distance of 24 inches between units.

24 inches clearance must be provided in front of the control box (access panels) and any other side requiring service.

Position unit where water, snow or ice from roof or overhang cannot fall directly on unit.

Position the outdoor unit a minimum of 12" from any wall or surrounding shrubbery to ensure adequate airflow.

See Figure 2 and Figure 3.

Cold climate considerations (heat pump only)



Precautions must be taken for units being installed in areas where snow accumulation and prolonged below-freezing temperatures occur.

- Units should be elevated 3-12 inches above the pad or rooftop, depending on local weather. This additional height will allow drainage of snow and ice melted during defrost cycle prior to its refreezing. Ensure that drain holes in unit base pan are not obstructed, preventing drainage of defrost water (Figure 4).
- If possible, avoid locations that are likely to accumulate snow drifts. If not possible, a snow drift barrier should be installed around the unit to prevent a build-up of snow on the sides of the unit.

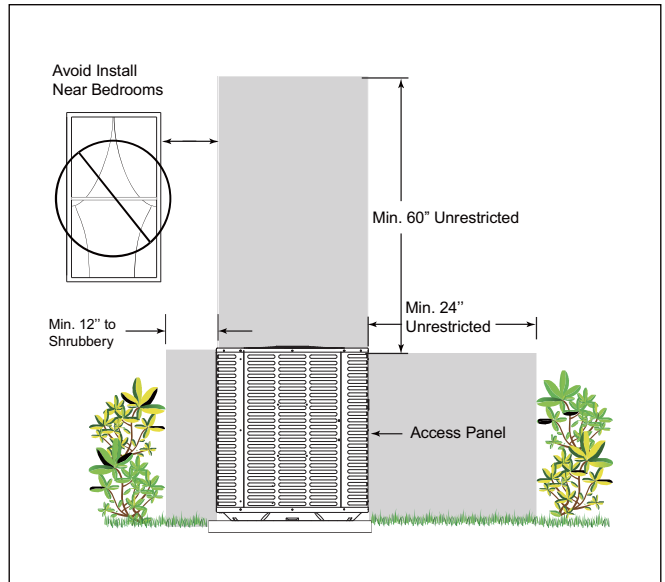

Figure 2

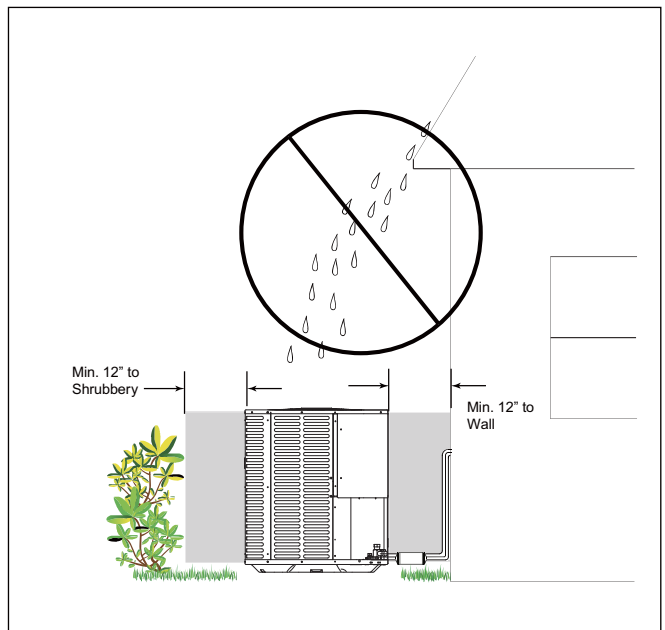

Figure 3

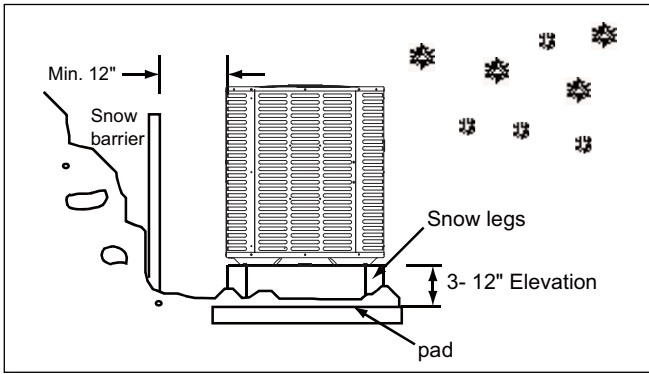

Figure 4

3. Unit preparation

3.1 Pre-installation

STEP 1 - Check for damage and report promptly to the carrier any damage found to the unit (Figure 5).

STEP 2 - Instruments must be designed to install/serve R410A equipments.

- Gauge sets, hoses, refrigerant containers and recovery system must be designed to handle the POE type oils.
- Manifold sets should be 800 PSIG high side and 250 PSIG low side.
- All hoses must have a 700 PSIG service pressure rating.
- Leak detectors should be designed to detect R410A.
- Recovery equipments (including refrigerant recovery containers) must be specifically designed to handle R410A.
- Do not use an R22 TXV.

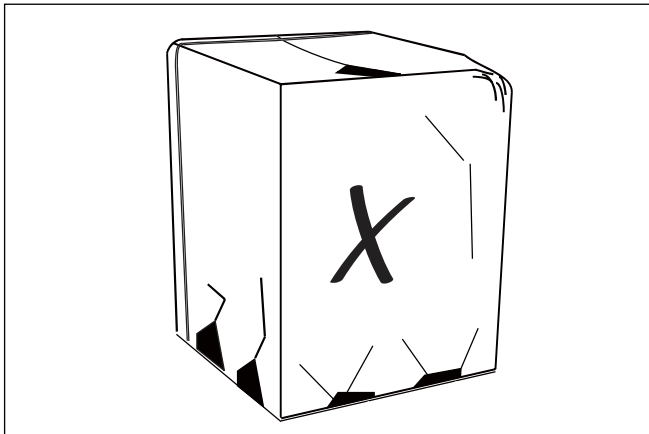

Figure 5

4. Setting up the unit

4.1 Pad installation

When installing the unit on a support pad, such as a concrete slab, consider the following:

- The pad must be at least 1-2" larger than the unit on all sides.
- The pad must be separate from any structure.
- The pad must be level.

- The pad must be high enough above grade to allow for drainage.
- The pad location must comply with National, State and Local codes.



These instructions are intended to provide a method to tie-down system to concrete slab as a securing procedure for high wind areas. Check Local Codes for tie-down methods and protocols.

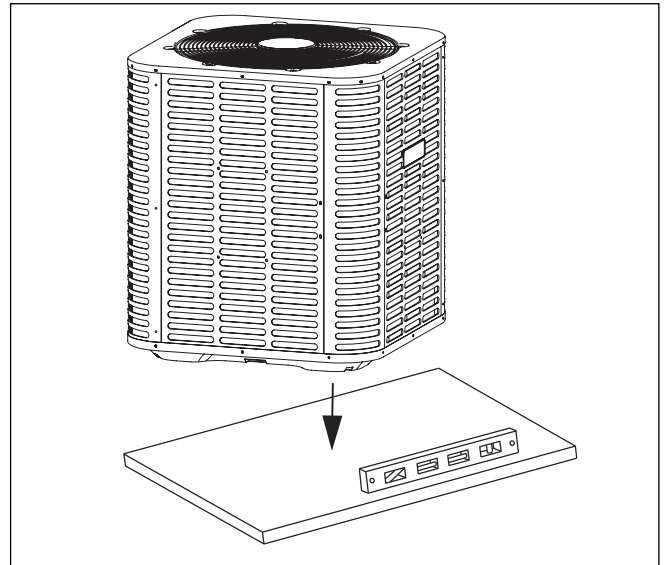

Figure 6

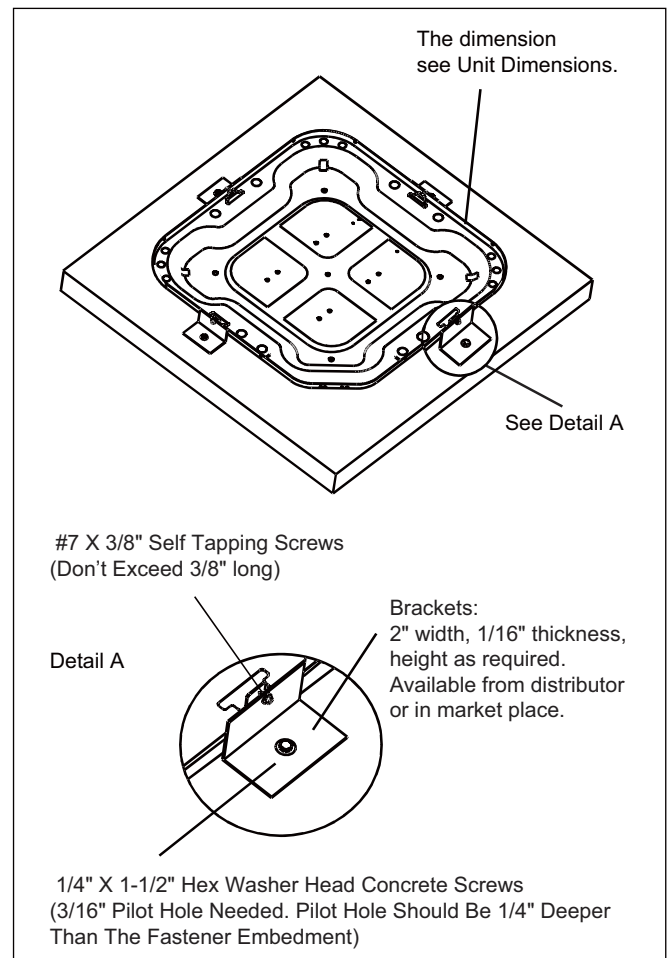

Figure 7

5. Refrigerant line considerations

5.1 Service valve connection sizes

Model		Suction line connection	Liquid line connection
AC	HP		
18	18	3/4	3/8
24	24	3/4	3/8
30	30	3/4	3/8
36	36	3/4	3/8
/	42	3/4	3/8
42	/	7/8	3/8
48	48	7/8	3/8
60	60	7/8	3/8

Table 2

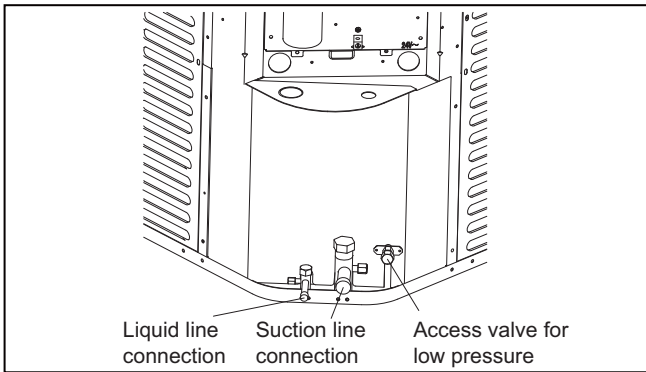

Figure 8

5.2 Refrigerant line sizes

Model	Suction line		Liquid line	
	optional	standard	optional	standard
18	5/8	3/4	5/16	3/8
24	5/8	3/4	5/16	3/8
30	5/8	3/4	5/16	3/8
36	5/8	3/4	5/16	3/8
42	3/4	7/8	5/16	3/8
48	7/8	1-1/8	1/2	3/8
60	7/8	1-1/8	1/2	3/8

Table 3

5.3 Refrigerant piping limits and required refrigerant line length

Model	Liquid line (Inches)	Total equivalent length(Feet)					
		25	50	75	100	125	150
		Maximum vertical length(Feet)					
18	5/16	25	50	60	58	40	30
	3/8	25	50	60	60	40	30
24	5/16	25	36	29	23	16	9
	3/8	25	50	60	60	40	30
30	5/16	25	49	38	27	17	6
	3/8	25	50	60	60	40	30
36	5/16	25	50	37	22	7	N/A
	3/8	25	50	60	60	40	30
42	5/16	25	23	4	N/A	N/A	N/A
	3/8	25	50	43	36	30	24
48	1/2	25	50	56	55	40	30
	3/8	25	46	38	30	22	15
60	1/2	25	50	60	60	40	30
	3/8	25	50	56	44	32	20

Table 4

Model	Suction line (Inches)	Total suction line length(Feet)			
		25	50	100	150
		Coefficient			
18	5/8	1.00	0.97	0.94	0.90
	3/4	1.00	0.98	0.95	0.92
24	5/8	1.00	0.97	0.94	0.90
	3/4	1.00	0.98	0.95	0.92
30	5/8	1.00	0.97	0.94	0.90
	3/4	1.00	0.98	0.96	0.93
36	5/8	1.00	0.97	0.94	0.90
	3/4	1.00	0.99	0.97	0.96
42	3/4	1.00	0.98	0.97	0.95
	7/8	1.00	0.99	0.98	0.97
48	7/8	1.00	0.98	0.97	0.96
	1-1/8	1.00	0.99	0.98	0.97
60	7/8	0.99	0.98	0.94	0.90
	1-1/8	1.00	0.99	0.98	0.97

Table 5 Suction line length/size VS capacity multiplier



Using suction line larger than shown in chart will result in poor oil return and is not recommended.

For example: the system capacity published in AHRI is 17800 Btu/h. This data is based on the AHRI test condition and 25 feet line set with standard suction tube size (3/4" tube). If you need to add the line set more than 25 feet or use the optional suction tube size, you need to recalculate the capacity with the coefficient in the table. For 50 feet line and 5/8" suction tube, the capacity will be $17800 \times 0.97 = 17266$ Btu/h.

Determine required line length and lift. You will need this later in Section 14.

Total Line Length = _____ Feet.

Total Vertical Change(Lift) = _____ Feet.

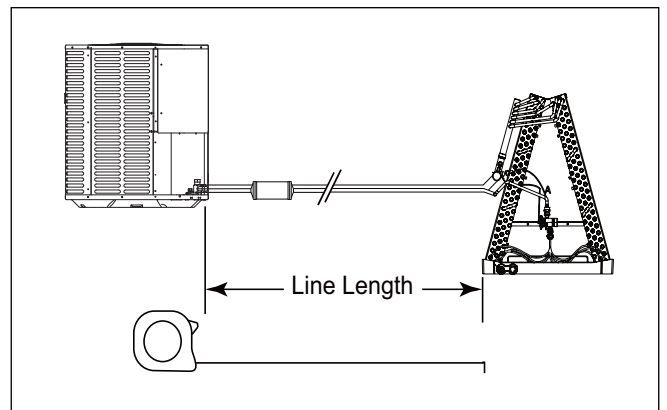

Figure 9

5.4 Refrigerant line insulation



The suction line must always be insulated. DO NOT allow the Liquid Line and Suction Line to come in direct (metal to metal) contact.

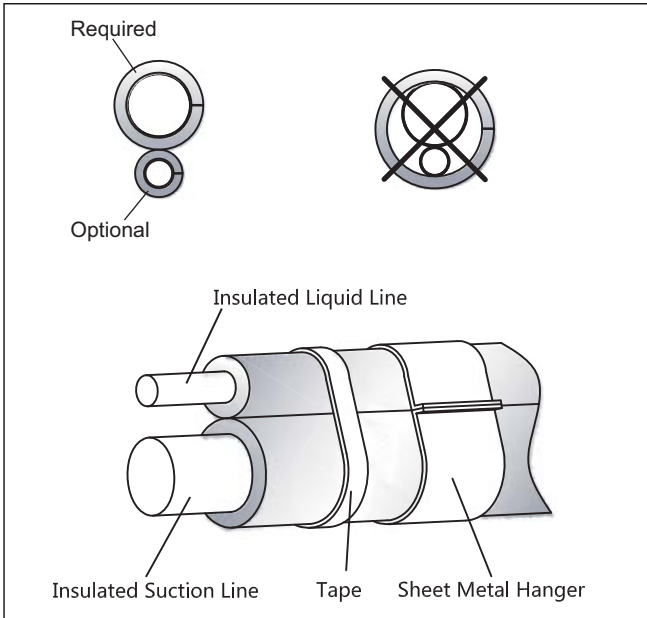

Figure 10

5.5 Reuse existing refrigerant lines

CAUTION:

If using existing refrigerant lines make certain that all joints are brazed, not soldered.

For retrofit applications, where the existing refrigerant lines will be used, the following precautions should be taken:

- Ensure that the refrigerant lines are the correct size. Refer to Section 5.1 listed and Table 3.
- Ensure that the refrigerant lines are free of leaks, acid, and oil.

The manufacturer recommends installing only approved matched indoor and outdoor systems. All of the manufacturer's split systems are AHRI certified. Some of the benefits of installing approved matched indoor and outdoor split systems are maximum efficiency, optimum performance and the best overall system reliability.

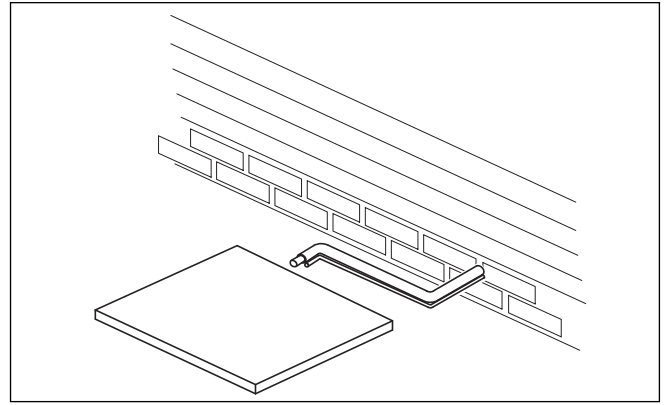

Figure 11

6. Refrigerant line routing

6.1 Precautions



Take precautions to prevent noise within the building structure due to vibration transmission from the refrigerant lines. For example:

- When the refrigerant lines have to be fastened to floor joists or other framing in a structure, use isolation type hangers.
- Isolation hangers should also be used when refrigerant lines are run in stud spaces or enclosed ceilings.
- Where the refrigerant lines run through a wall or sill, they should be insulated and isolated.
- Isolate the lines from all ductwork.
- Minimize the number of 90° turns.
- Use PVC piping as a conduit for all underground installations as shown in Figure 15. Buried lines should be kept as short as possible.
- The lines should not obstruct service access to the coil, air handling system or filter.
- Care must also be taken to isolate the refrigerant lines to minimize noise transmission from the equipment to the structure.



Comply with National, State, and Local Codes when isolating line sets from joists, rafters, walls or other structural elements.

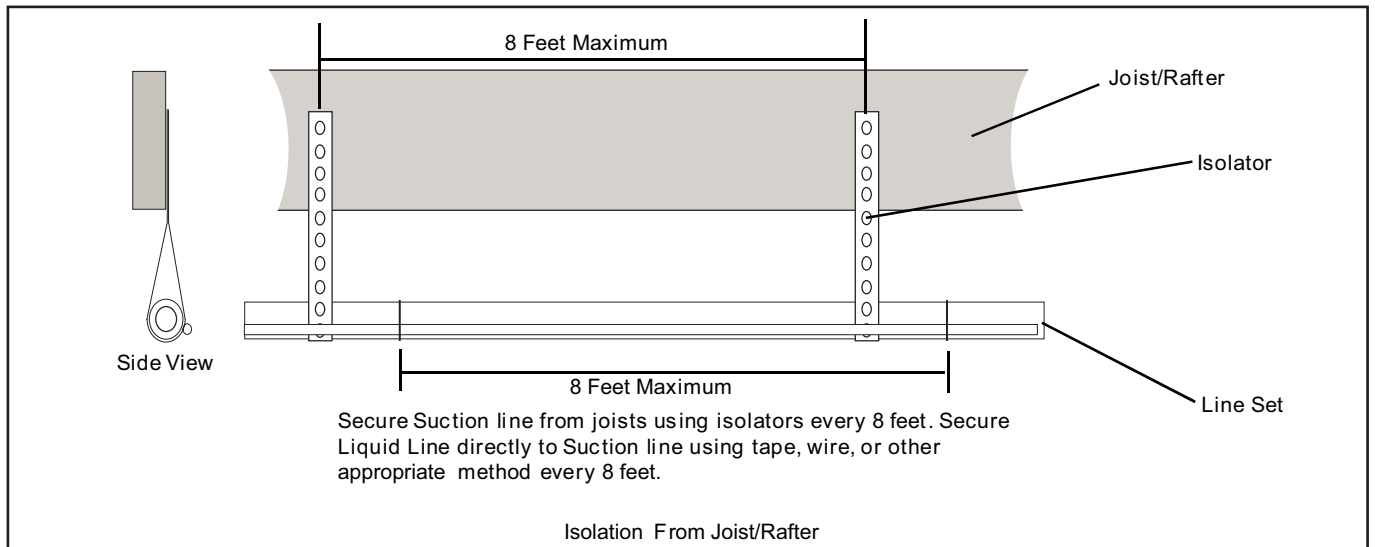

Figure 12

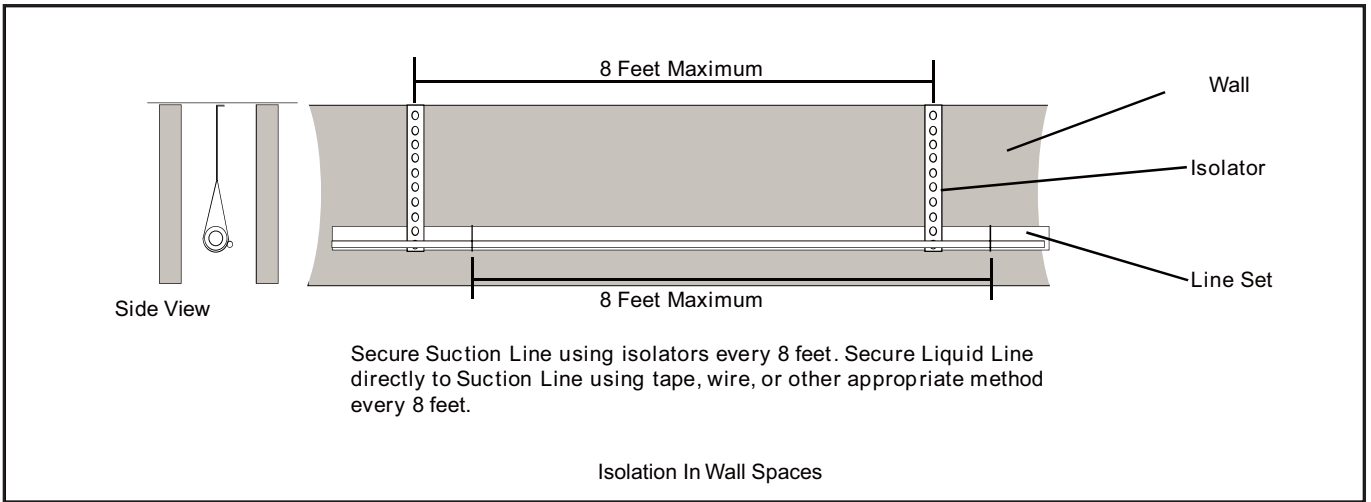

Figure 13

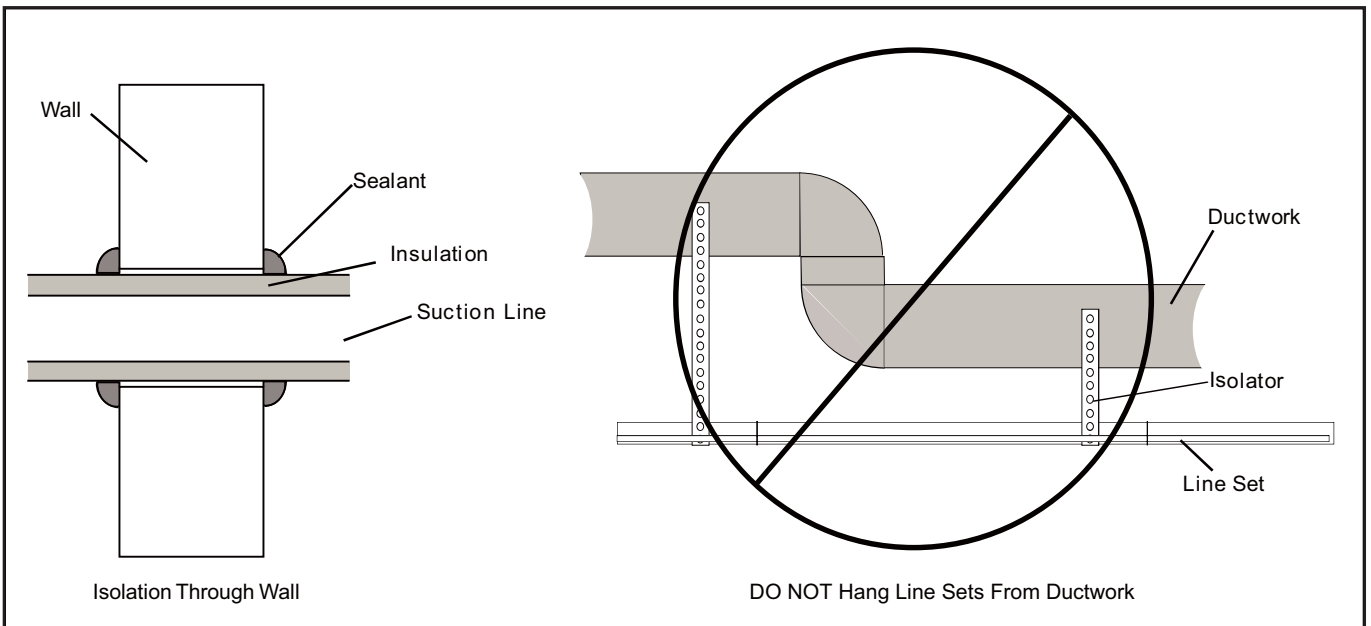

Figure 14

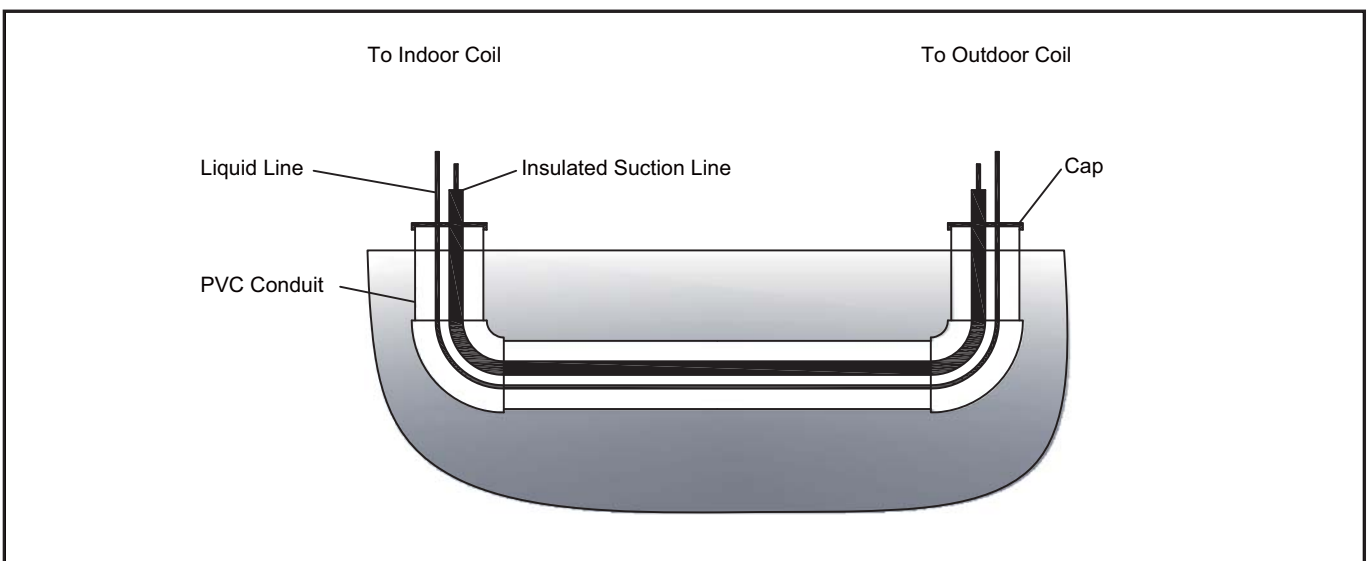

Figure 15

7. Refrigerant line brazing

7.1 Braze the refrigerant lines

1. Remove caps or plugs. Use a deburring tool to deburr the pipe ends. Clean both internal and external surfaces of the tubing using an emery cloth.

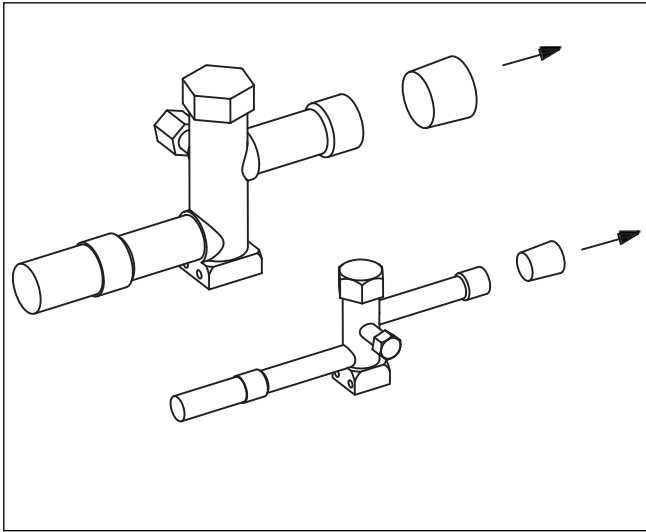

Figure 16

2. Remove the pressure tap cap from both service valves.

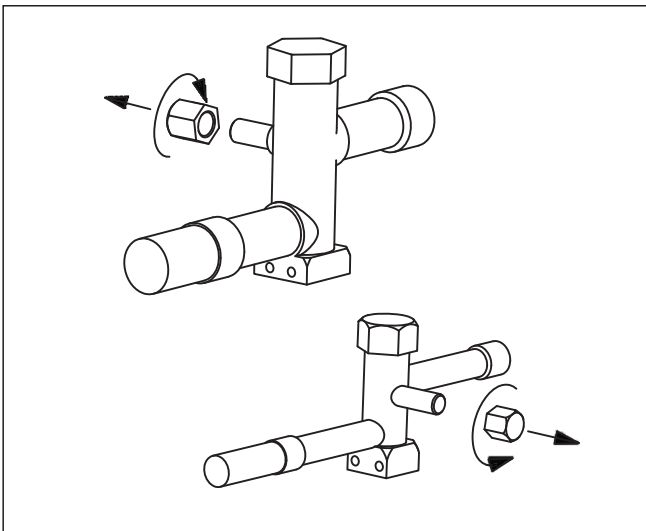

Figure 17

3. Purge the refrigerant lines and indoor coil with dry nitrogen.

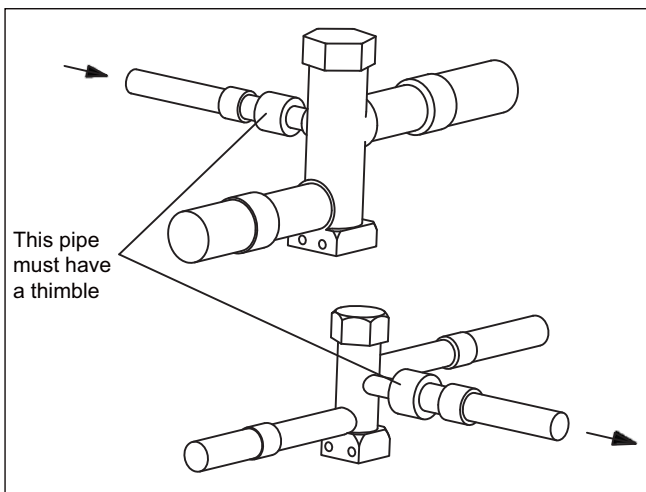

Figure 18

4. Wrap a wet rag around the valve body to avoid heat damage and continue the dry nitrogen purge (Figure 19).

Braze the refrigerant lines to the service valves.

Check liquid line filter drier's directional flow arrow to confirm correct direction of refrigeration flow (away from outdoor unit and toward evaporator coil) as illustrated. Brazing the filter drier to the Liquid Line.

Continue the dry nitrogen purge. Do not remove the wet rag until all brazing is completed.



Remove the wet rag before stopping the dry nitrogen purge.

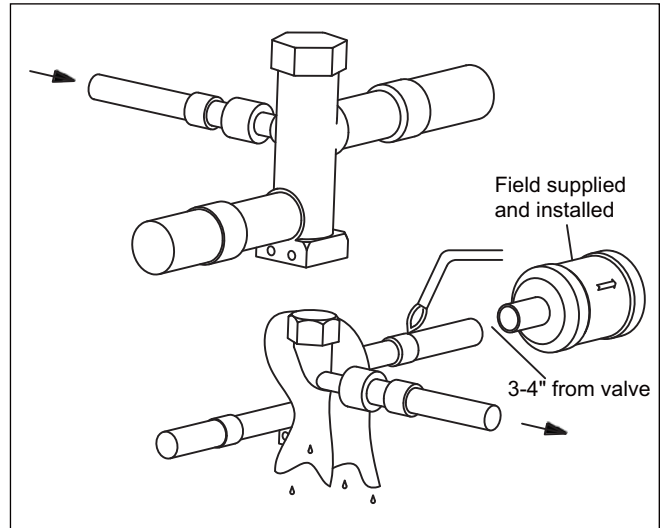

Figure 19

5. Replace the pressure tap caps after the service valves have cooled.

Note: Do not over tighten (between 40 and 60 inch-lbs. maximum).

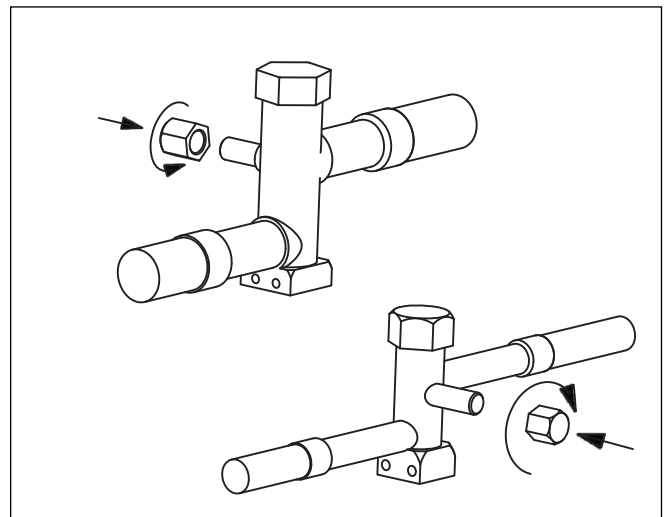

Figure 20

8. Refrigerant line leak check

8.1 Check for leaks

1. Pressurize the refrigerant lines and evaporator coil to 150 PSIG using dry nitrogen.

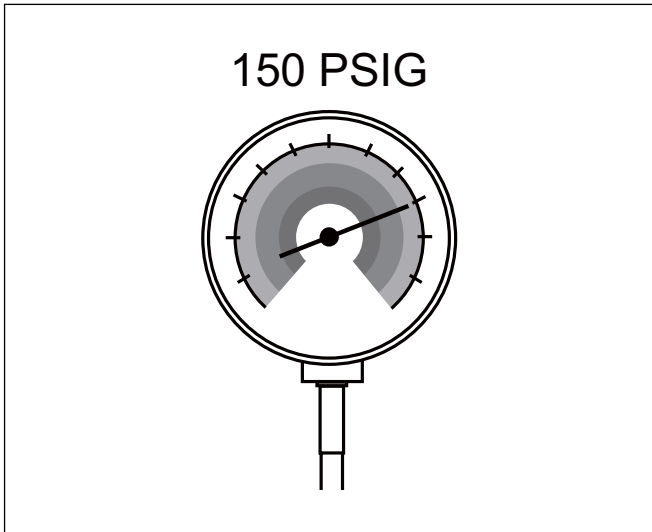

Figure 21

2. Check for leaks by using a soapy solution or bubbles at each brazed location.

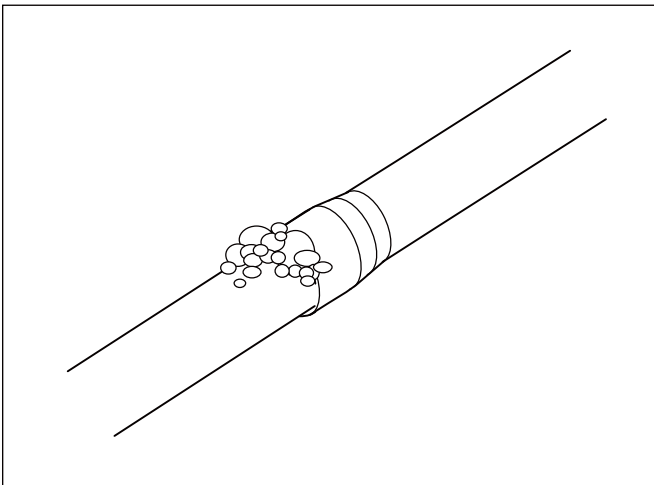

Figure 22

Remove nitrogen pressure and repair any leaks before continuing.

9. Evacuation

9.1 Evacuate the refrigerant lines and indoor coil



Do not open the service valves until the refrigerant lines and indoor coil leak check and evacuation are complete.

1. Evacuate until the micron gauge reads no higher than 350 microns, then close off the valve to the vacuum pump.

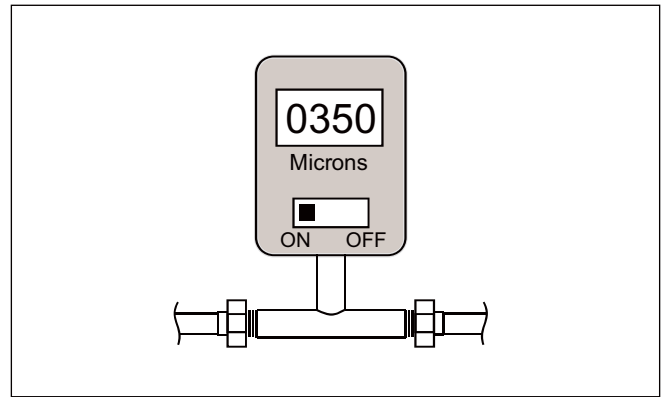

Figure 23

2. Observe the micron gauge. Evacuation is complete if the micron gauge does not rise above 500 microns in one (1) minute.

Once evacuation is complete blank off the vacuum pump and micron gauge, and close the valves on the manifold gauge set.



Figure 24

10. Service valves

10.1 Open the service valves



WARNING:

Extreme caution should be exercised when opening the Liquid Line Service Valve. Turn counterclockwise until the valve stem just touches the rolled edge. No torque is required. Failure to follow this warning will result in abrupt release of system charge and may result in personal injury and /or property damage.



Leak check and evacuation must be completed before opening the service valves.

1. Remove service valve cap (Figure 25).
2. Fully insert hex wrench into the stem and back out counterclockwise until valve stem just touches the rolled edge.
3. Replace the valve stem cap to prevent leaks. Tighten finger tight plus an additional 1/6 turn.

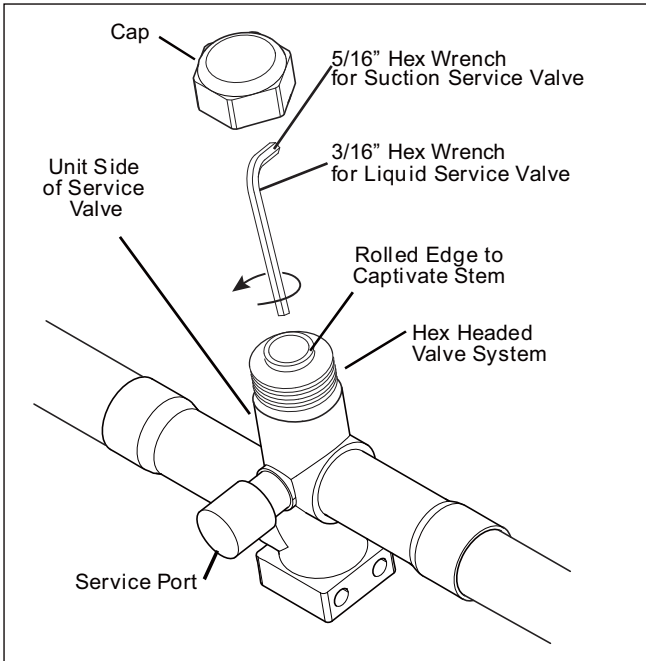

Figure 25

11. Electrical - low voltage

11.1 Low Voltage Maximum Wire Length

Table 6 defines the maximum total length of low voltage wiring from the outdoor unit to the indoor unit and to the thermostat.

24 Volts - Wire size	Max. wire length
18 AWG	150 Ft.
16 AWG	225 Ft.
14 AWG	300 Ft.

Table 6

11.2 Low voltage hook-up diagrams

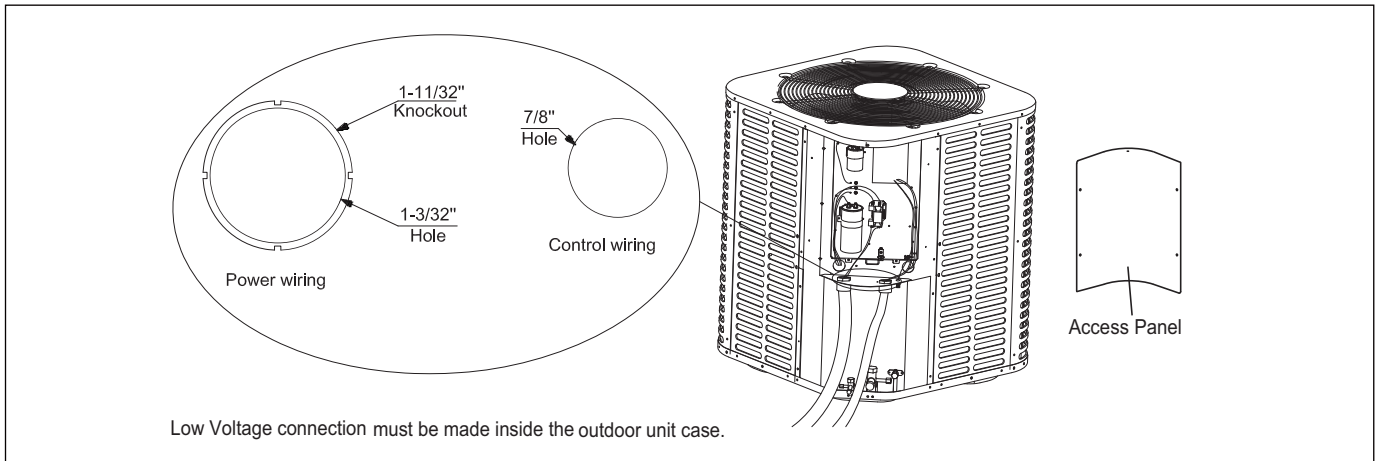
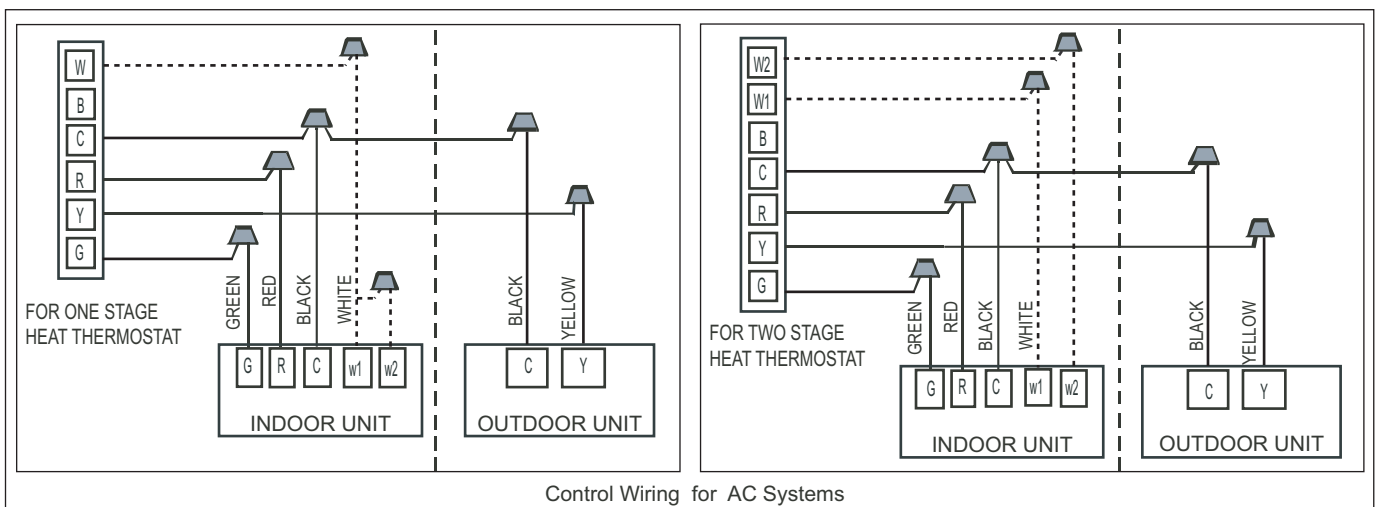

Figure 26



Control Wiring for AC Systems

Figure 27

Notes: "...." The electric auxiliary heat connection(optional).

W : Electric auxiliary heat signal.

W1 : The first Electric auxiliary heat signal.

W2 : The second Electric auxiliary heat signal.

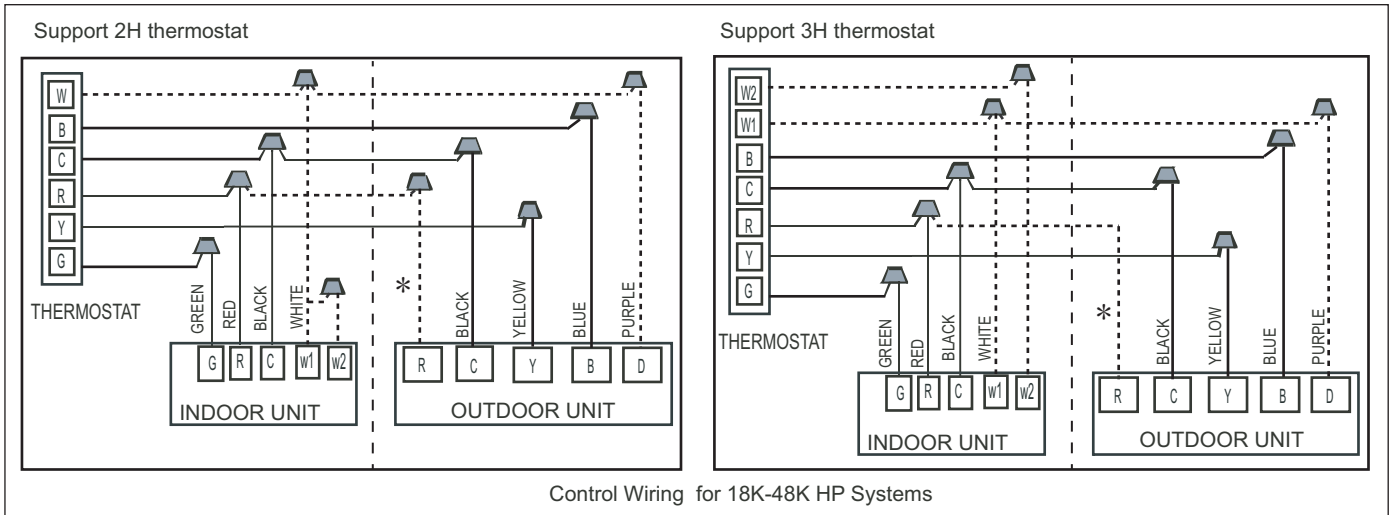

Figure 28

- Notes: "----" The electric auxiliary heat connection(option).
 W : Electric auxiliary heat signal.
 W1 : The first Electric auxiliary heat signal.
 W2 : The second Electric auxiliary heat signal.
 D signal is connect to the Electric auxiliary heat or the first Electric auxiliary heat.
 "*": Outdoor unit signal. Only for single-stage compressor systems.

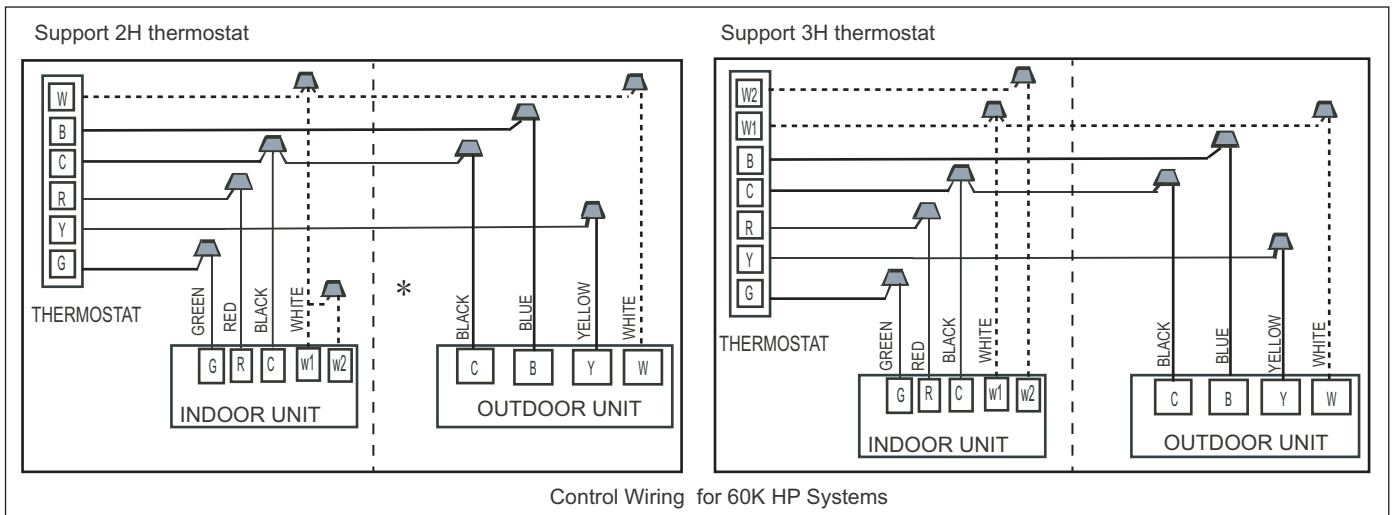

Figure 29

- Notes: "----" The electric auxiliary heat connection(option).
 W : Electric auxiliary heat signal,connect to the Electric auxiliary heat or the first Electric auxiliary heat.
 W1 : The first Electric auxiliary heat signal.
 W2 : The second Electric auxiliary heat signal.

12. Electrical - high voltage

12.1 High voltage power supply

WARNING: LIVE ELECTRICAL COMPONENTS!

During installation, testing, servicing, and trouble shooting of this product, it may be necessary to work with live electrical components. Failure to follow all electrical safety precautions when exposed to live electrical components could result in death or serious injury.

The high voltage power supply must agree with the equipment nameplate.

Power wiring must comply with National, State and Local Codes.

Follow instructions on unit wiring diagram located on the inside of the access panel.

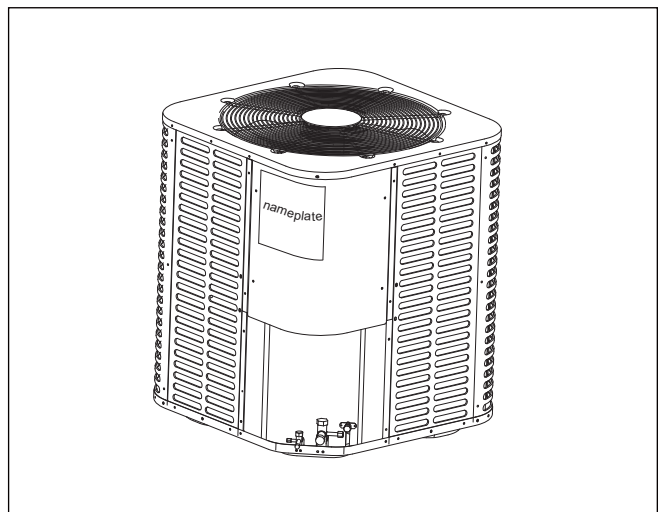

Figure 30

12.2 High voltage disconnect switch

Install a separate disconnect switch at the outdoor unit.

Field provided flexible electrical conduit must be used for high voltage wiring.

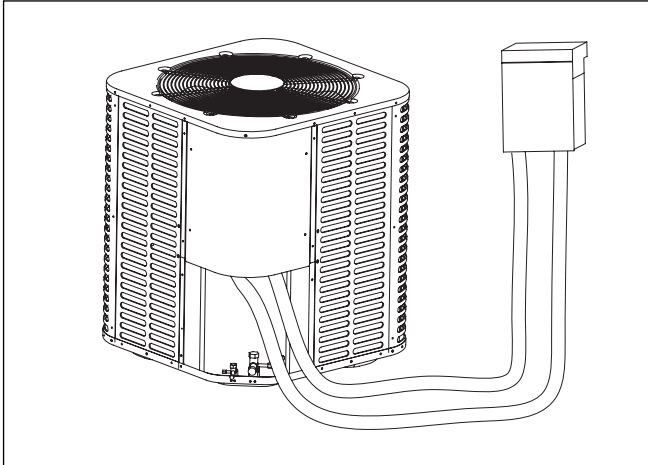

Figure 31

12.3 High voltage ground

Ground the outdoor unit per National, State and Local Code requirements.

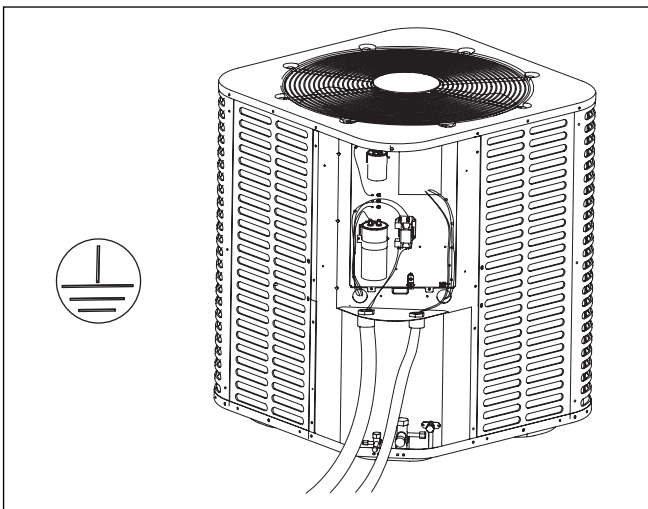

Figure 32

13. Start up

13.1 System start up

1. Ensure Sections 7, 8, 9, 10, 11 and 12 have been completed.
2. Set System Thermostat to OFF.

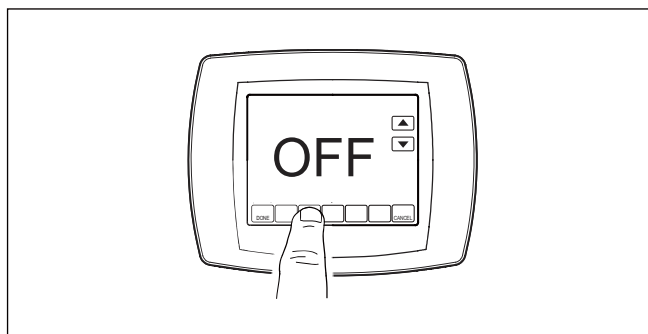

Figure 33

3. Turn on disconnect to apply power to the indoor and outdoor units.

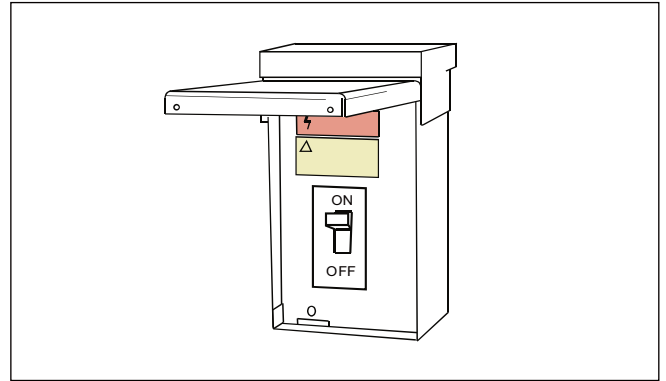

Figure 34

4. Wait one (1) hour before starting the unit if compressor crankcase heater is used and the outdoor ambient temperature is below 70 °F.



Figure 35

5. Set system thermostat to ON.

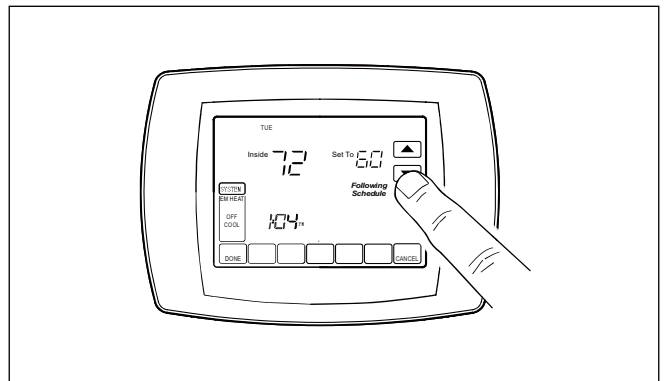

Figure 36

14. System charge adjustment

14.1 Charging: Weigh-In Method

Weigh-In Method can be used for the initial installation, or anytime a system charge is being replaced. Weigh-In Method can also be used when power is not available to the equipment site or operating conditions (indoor/outdoor temperatures) are not in range to verify with the liquid line pressure charging method.

Model	Factory Charge	Charge multiplier for liquid line length		
		5/16"	3/8"	1/2"
All models	The data on nameplate	0.4 oz/ft	0.6 oz/ft	1.2 oz/ft

Table 7



The factory charge in the outdoor unit is sufficient for 15 feet of standard size interconnecting liquid line.

New Installations — Calculating additional charge for lineset greater than 15 feet.

1. Total Line Length (ft) = _____ (a)
2. Standard Line set (ft) = 15 (b)
3. (a) minus (b) = _____ (c)
4. Refrigerant Multiplier = _____ (d)
5. Refrigerant Adder (c*d) = _____ (e*)

*If lineset is less than 15 feet, (e) = 0

Sealed-System Repairs — Calculating total system charge.

1. Total Line Length (ft) = _____ (a)
2. Standard Line set (ft) = 15 (b)
3. (a) minus (b) = _____ (c)
4. Refrigerant Multiplier = _____ (d)
5. Refrigerant Adder (c*d) = _____ (e*)
6. Factory Charge (nameplate) = _____ (f)
7. Total System Charge (e+f) = _____

*If line set is less than 15 feet, (e) = 0



The only mode approved for validating system charge is while in Cooling Mode. Outdoor Temperature must be between 55°F and 115°F with Indoor Temperature kept between 70°F and 80°F.

14.2 Liquid line pressure charging and refrigerant adjustment in cooling (above 55°F outdoor temp.)

- For 5TON AC unit, the Outdoor Temperature must be between **65°F** and **105°F**

1. Check the outdoor ambient temperatures.

Liquid line pressure (in cooling mode) is the only recommended method of charging above 55°F outdoor ambient temperatures.

For outdoor ambient temperatures below 55°F, use weigh-in charge method.

Note: It is important to return in the spring or summer to accurately charge the system in the cooling mode when outdoor ambient temperature is above 55°F.

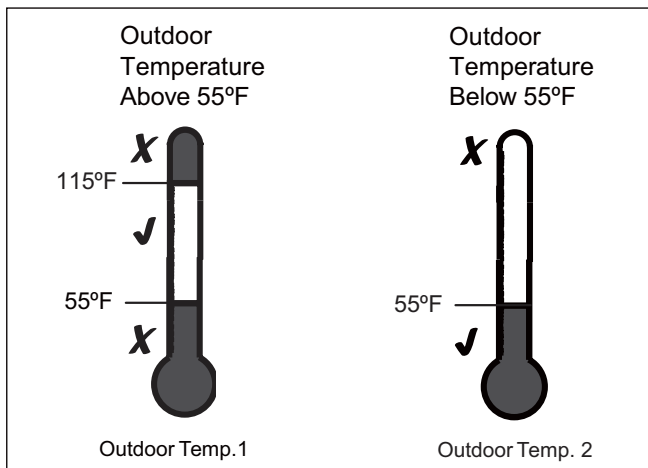

Figure 37

For best results the indoor temperature should be kept between 70°F and 80°F.

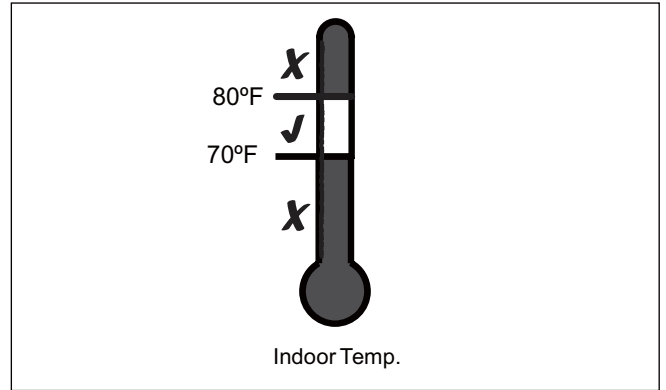

Figure 38

Note: The temperature tolerance for actual approach is ± 3°F.

2. Ensure Sections 7, 8, 9, 10, 11, 12 and 13 have been completed.
3. Stabilize the system by operating for a minimum of 20 minutes.



At startup, or whenever charge is removed or added, the system must be operated for a minimum of 20 minutes to stabilize before accurate measurements can be made.

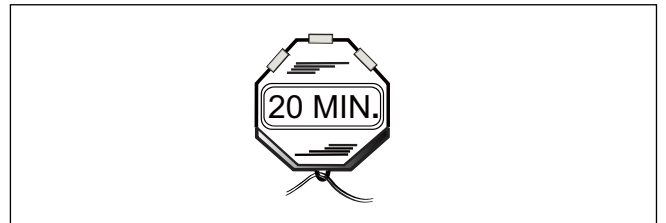

Figure 39

Note: The pressure tolerance for actual approach is ± 5psig

4. Calculate liquid line pressure (According to Refrigerant Charging Chart)
 - ▶ Measured Suction Line Pressure = _____ PSIG
 - ▶ Outdoor Ambient Temperature = _____ °F
 - ▶ Calculate Liquid Line Pressure = _____ PSIG

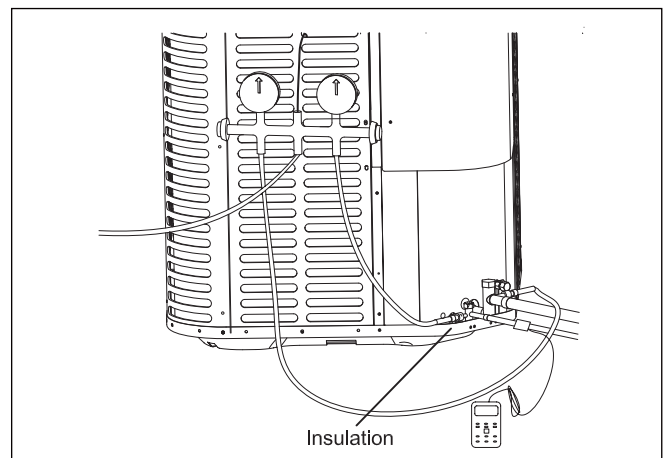

Figure 40

REFRIGERANT CHARGING CHART FOR AC SYSTEM

Cooling Mode		16 SEER R410A AC Charge Chart 1.5 TON												
		Outdoor Ambient Temperature(°F)												
		55	60	65	70	75	80	85	90	95	100	105	110	115
Suction Pressure at Large Service Valve(psig)	165			252	269	286	306	326	350	373	395	419	442	467
	161			250	267	284	304	324	348	371	393	417	440	464
	157			248	265	282	302	322	345	368	390	414	437	461
	153		228	244	262	280	300	320	342	365	387	411	435	459
	149		226	242	260	277	298	318	339	362	385	409	432	457
	145		224	240	258	275	296	316	337	360	382	406	430	455
	141	205	222	238	255	272	293	314	334	357	380	404	428	453
	137	203	220	236	253	269	291	312	332	355	377	402	426	451
	133	201	218	234	250	266	288	310	330	353	375	400	424	449
	129	199	216	232	248	264	286	308	328	351	374	398	422	447
	125	198	214	230	246	262	284	306	326	349	372	396	420	445
	121	196	212	228	244	260	282	304	324	347	370	394	418	443
	117	194	210	226	242	258	280	302	322	345	367	392	416	441
	113	192	208	224	240	256	278	300	320	343	365	390	414	439
	109	190	206	222	238	254	276	298	318	340	362	387	412	437
	105	188	204	220	236	252	273	295	316	338	360	385	410	435

Cooling Mode		16 SEER R410A AC Charge Chart 2 TON												
		Outdoor Ambient Temperature(°F)												
		55	60	65	70	75	80	85	90	95	100	105	110	115
Suction Pressure at Large Service Valve(psig)	165			258	277	295	316	337	358	382	405	430	454	479
	161			256	275	293	314	335	356	380	403	428	452	477
	157			254	273	291	312	333	354	378	401	426	450	475
	153		236	252	271	289	310	331	352	376	399	424	448	473
	149		234	250	269	287	308	329	350	374	397	422	446	471
	145		232	248	267	285	306	327	348	372	395	419	443	469
	141	214	230	246	265	283	304	325	346	370	393	417	441	467
	137	212	228	244	262	280	301	322	343	367	391	415	439	465
	133	210	226	242	260	278	299	320	341	365	389	413	437	463
	129	208	224	240	258	276	297	318	339	363	387	411	435	461
	125	206	222	238	256	274	295	316	337	361	385	409	433	459
	121	204	220	236	254	272	293	314	335	359	383	407	431	457
	117	202	218	234	252	270	291	312	333	357	381	405	429	455
	113	199	216	232	250	268	289	310	331	355	379	403	427	453
	109	197	214	230	248	266	287	308	329	353	377	401	425	451
	105	195	212	228	246	264	285	306	327	351	375	399	423	449

Cooling Mode		16 SEER R410A AC Charge Chart 2.5 TON												
		Outdoor Ambient Temperature(°F)												
		55	60	65	70	75	80	85	90	95	100	105	110	115
Suction Pressure at Large Service Valve(psig)	165			261	280	299	319	340	360	382	404	431	457	483
	161			259	278	297	317	338	358	380	401	428	455	481
	157			257	276	295	315	336	356	377	398	426	453	479
	153		240	255	274	293	313	333	353	375	396	424	451	477
	149		238	253	272	291	311	331	351	373	394	422	449	475
	145		236	251	270	289	309	329	349	371	392	420	447	473
	141	218	234	249	268	287	307	327	347	369	390	418	445	471
	137	216	232	247	266	285	305	325	345	367	388	416	443	469
	133	214	230	245	264	283	303	323	343	364	385	413	441	467
	129	212	228	243	262	281	301	321	341	362	383	411	439	465
	125	210	226	241	260	279	299	319	339	360	381	409	437	463
	121	207	223	239	258	277	297	317	337	358	379	407	435	461
	117	204	221	237	256	275	295	315	335	356	377	405	433	459
	113	202	219	235	254	273	293	313	333	354	375	403	431	457
	109	200	217	233	252	271	291	311	331	352	373	401	429	455
	105	198	215	231	250	269	289	309	329	350	371	399	427	453

Cooling Mode		16 SEER R410A AC Charge Chart 3 TON												
		Outdoor Ambient Temperature(°F)												
		55	60	65	70	75	80	85	90	95	100	105	110	115
Suction Pressure at Large Service Valve(psig)	165			259	277	295	316	337	358	384	410	435	460	486
	161			257	275	293	314	335	356	382	408	433	458	484
	157			255	273	291	312	333	354	380	406	431	456	482
	153		235	253	271	289	310	331	352	378	404	429	454	480
	149		233	251	269	287	308	329	350	376	402	427	452	478
	145		231	249	267	285	306	327	348	374	400	425	450	476
	141	214	229	247	265	283	304	325	346	372	398	423	448	474
	137	212	227	245	263	281	302	323	344	369	396	423	446	472
	133	210	225	243	261	279	300	321	342	368	394	419	444	470
	129	208	223	241	259	277	298	319	340	366	392	417	442	468
	125	206	221	239	257	275	296	317	338	364	390	415	440	466
	121	204	219	237	255	273	294	315	336	362	388	413	438	464
	117	202	217	235	253	271	292	313	334	360	386	411	436	462
	113	200	215	233	251	269	290	311	332	358	384	409	434	460
	109	198	213	231	249	267	288	309	330	356	382	407	432	458
	105	196	211	229	247	265	286	307	328	354	380	405	430	456

Cooling Mode		16 SEER R410A AC Charge Chart 3.5 TON													
		Outdoor Ambient Temperature(°F)													
		55	60	65	70	75	80	85	90	95	100	105	110	115	
Suction Pressure at Large Service Valve(psig)		Liquid Pressrue at Small Service Value(psig)													
		165			258	277	296	314	332	350	376	401	427	452	478
		161			256	275	294	312	330	348	374	399	425	450	476
		157			254	273	292	310	328	346	372	397	423	448	474
		153		237	252	271	290	308	326	344	370	395	421	446	472
		149		235	250	269	288	306	324	342	368	393	419	444	470
		145		233	248	267	286	304	322	340	366	391	417	442	468
		141	215	231	246	265	284	302	320	338	364	389	415	440	466
		137	213	229	244	263	281	299	318	336	362	387	413	438	464
		133	211	227	242	260	278	297	315	334	360	385	411	436	462
		129	209	225	240	258	275	294	313	332	358	383	409	434	460
		125	207	223	238	256	273	292	311	330	356	381	407	432	458
		121	205	221	236	254	271	290	309	328	354	379	405	430	456
		117	202	218	234	252	269	288	307	326	352	377	403	428	454
		113	199	216	232	250	267	286	305	324	350	375	401	426	452
109	197	214	230	248	265	284	303	322	348	373	399	424	450		
105	195	212	228	246	263	282	301	320	346	371	397	422	448		

Cooling Mode		16 SEER R410A AC Charge Chart 4 TON													
		Outdoor Ambient Temperature(°F)													
		55	60	65	70	75	80	85	90	95	100	105	110	115	
Suction Pressure at Large Service Valve(psig)		Liquid Pressrue at Small Service Value(psig)													
		165			264	282	300	322	343	364	388	412	437	464	491
		161			262	280	298	320	341	362	386	410	435	462	489
		157			260	278	296	318	339	360	384	408	433	460	487
		153		239	258	276	294	316	337	358	382	406	431	458	485
		149		237	256	274	292	314	335	356	380	404	429	456	483
		145		235	254	272	290	312	333	354	378	402	427	454	481
		141	215	233	252	270	288	310	331	352	376	400	425	452	479
		137	213	231	250	268	286	308	329	350	374	398	423	450	477
		133	211	229	248	266	284	306	327	348	372	396	421	448	475
		129	209	227	246	264	282	304	325	346	370	394	419	446	473
		125	207	225	244	262	280	302	323	344	368	392	417	444	471
		121	205	223	242	260	278	300	321	342	366	390	415	442	469
		117	203	221	240	258	276	298	319	340	364	388	413	440	467
		113	201	219	238	256	274	296	317	338	362	386	411	438	465
109	199	217	236	254	272	294	315	336	360	384	409	436	463		
105	197	215	234	252	270	292	313	334	358	382	407	434	461		

Cooling Mode		16 SEER R410A AC Charge Chart 5 TON									
		Outdoor Ambient Temperature(°F)									
		65	70	75	80	85	90	95	100	105	
Suction Pressure at Large Service Valve(psig)		Liquid Pressrue at Small Service Value(psig)									
		165	273	294	317	339	361	383	404	431	458
		161	271	292	314	336	358	381	403	430	457
		157	269	289	311	334	356	379	401	428	455
		153	267	287	308	331	353	377	400	426	453
		149	266	285	306	328	350	374	398	424	451
		145	264	283	304	326	348	373	397	423	450
		141	262	281	302	324	346	371	395	421	448
		137	260	279	300	322	344	369	393	419	446
		133	259	278	298	320	342	367	392	418	443
		129	257	276	296	318	340	365	390	415	440
		125	255	274	294	316	338	363	388	413	438
		121	253	272	292	314	336	361	386	411	435
		117	252	271	291	313	335	360	384	409	433
		113	250	269	290	312	334	358	382	407	431
109	248	268	289	311	333	357	380	404	428		
105	246	266	288	310	331	355	378	402	426		

REFRIGERANT CHARGING CHART FOR HP SYSTEM

Cooling Mode		16SEER R410A HP Charge Chart 1.5TON(Cooling mode)													
		Outdoor Ambient Temperature(°F)													
		55	60	65	70	75	80	85	90	95	100	105	110	115	
Suction Pressure at Large Service Valve(psig)		Liquid Pressure at Small Service Valve(psig)													
		165			246	265	284	303	323	343	364	390	416	441	467
		161			244	263	282	301	321	341	362	388	414	439	465
		157			242	261	280	299	319	339	360	386	412	437	463
		153		221	240	259	278	297	317	337	358	384	410	435	461
		149		219	238	257	276	295	315	335	356	382	408	433	459
		145		217	236	255	274	293	313	333	354	380	406	431	457
		141	196	215	234	253	272	291	311	331	352	378	404	429	455
		137	195	213	232	251	269	288	309	328	350	376	402	427	453
		133	193	211	230	249	267	286	306	326	347	373	399	425	451
		129	191	209	228	247	265	284	304	323	344	370	397	423	449
		125	190	209	227	245	264	282	302	320	341	368	394	421	447
		121	190	208	226	244	262	280	300	320	341	367	393	419	445
		117	188	206	224	242	260	278	298	318	339	365	391	417	443
		113	186	204	222	240	258	276	296	316	337	363	389	415	441
109	184	202	220	238	256	274	294	314	335	361	387	413	439		
105	182	200	218	236	254	272	292	312	333	359	385	411	437		

Cooling Mode		16SEER R410A HP Charge Chart 2TON(Cooling mode)													
		Outdoor Ambient Temperature(°F)													
		55	60	65	70	75	80	85	90	95	100	105	110	115	
Suction Pressure at Large Service Valve(psig)		Liquid Pressure at Small Service Valve(psig)													
		165			255	274	294	313	335	358	381	407	434	461	486
		161			253	272	292	311	333	356	379	405	432	459	484
		157			251	270	290	309	331	354	377	403	430	457	482
		153		230	249	268	288	307	329	352	375	401	428	455	480
		149		228	247	266	286	305	327	350	373	399	426	453	478
		145		226	245	264	284	303	325	348	371	397	424	451	476
		141	204	224	243	262	282	301	323	346	369	395	422	449	474
		137	203	222	241	260	279	298	320	344	367	393	420	447	472
		133	201	220	239	258	277	296	318	342	365	391	418	445	470
		129	199	218	237	256	275	294	316	340	363	389	416	443	468
		125	197	216	235	254	273	292	314	338	361	387	414	441	466
		121	195	214	233	252	271	290	312	336	359	385	412	439	464
		117	193	212	231	250	269	288	310	334	357	383	410	437	462
		113	191	210	229	248	267	286	308	332	355	381	408	435	460
		109	189	208	227	246	265	284	306	330	353	379	406	433	458
105	187	206	225	244	263	282	304	328	351	377	404	431	456		

Cooling Mode		16SEER R410A HP Charge Chart 2.5TON(Cooling mode)													
		Outdoor Ambient Temperature(°F)													
		55	60	65	70	75	80	85	90	95	100	105	110	115	
Suction Pressure at Large Service Valve(psig)		Liquid Pressure at Small Service Valve(psig)													
		165			253	269	288	305	327	348	370	390	414	435	461
		161			251	267	286	303	325	346	368	388	412	433	459
		157			249	265	284	301	323	344	366	386	410	431	457
		153		231	247	263	282	299	321	342	364	384	408	429	455
		149		229	245	261	280	297	319	340	362	382	406	427	453
		145		227	243	259	278	295	317	338	360	380	404	425	451
		141	208	225	241	257	276	293	315	336	358	378	402	423	449
		137	206	223	239	255	274	291	313	334	356	376	400	421	447
		133	204	221	237	253	272	289	311	332	354	374	398	419	445
		129	202	219	235	251	270	287	309	330	352	372	396	417	443
		125	199	215	232	249	267	285	307	328	350	370	394	415	441
		121	195	213	230	247	267	285	306	327	348	368	392	413	439
		117	193	211	228	245	265	283	304	325	346	366	390	411	437
		113	191	209	226	243	263	281	302	323	344	364	388	409	435
		109	189	207	224	241	261	279	300	321	342	362	386	407	433
105	187	205	222	239	259	277	298	319	340	360	384	405	431		

Cooling Mode		16SEER R410A HP Charge Chart 3TON(Cooling mode)													
		Outdoor Ambient Temperature(°F)													
		55	60	65	70	75	80	85	90	95	100	105	110	115	
Suction Pressure at Large Service Valve(psig)		Liquid Pressure at Small Service Valve(psig)													
		165			260	278	296	314	336	359	381	402	427	454	482
		161			258	276	294	312	334	357	379	400	425	452	480
		157			256	274	292	310	332	355	377	398	423	450	478
		153		236	254	272	290	308	330	352	374	395	420	448	476
		149		234	252	270	288	306	328	350	372	393	418	446	474
		145		232	250	268	286	304	326	347	369	390	416	444	472
		141	212	230	248	266	284	302	323	345	366	388	413	442	470
		137	210	228	246	264	282	300	321	342	363	385	411	439	468
		133	208	226	244	262	280	298	319	339	360	382	408	437	466
		129	206	224	242	260	278	296	316	337	357	379	406	435	464
		125	204	222	240	258	276	294	314	335	355	377	404	433	462
		121	202	220	238	256	274	292	312	333	353	375	402	431	460
		117	200	218	236	254	272	290	310	331	351	373	400	429	458
		113	198	216	234	252	270	288	308	329	349	371	398	427	456
		109	196	214	232	250	268	286	306	327	347	369	396	425	454
105	194	212	230	248	266	284	304	325	345	367	394	423	452		

Cooling Mode		16SEER R410A HP Charge Chart 3.5TON(Cooling mode)													
		Outdoor Ambient Temperature(°F)													
		55	60	65	70	75	80	85	90	95	100	105	110	115	
Suction Pressure at Large Service Valve(psig)		Liquid Pressure at Small Service Valve(psig)													
		165			254	271	288	305	327	348	370	394	417	441	464
		161			252	269	286	303	325	346	368	392	415	439	462
		157			250	267	284	301	323	344	366	390	413	437	460
		153		231	248	265	282	299	321	342	364	388	411	435	458
		149		229	246	263	280	297	319	340	362	386	409	433	456
		145		227	244	261	278	295	317	338	360	384	407	431	454
		141	208	225	242	259	276	293	315	336	358	382	405	429	452
		137	206	223	240	257	274	291	313	334	356	380	403	427	450
		133	204	221	238	255	272	289	311	332	354	378	401	425	448
		129	202	219	236	253	270	287	309	330	352	376	399	423	446
		125	200	217	234	251	268	285	307	328	350	374	397	421	444
		121	198	215	232	249	266	283	305	326	348	372	395	419	442
		117	196	213	230	247	264	281	303	324	346	370	393	417	440
		113	194	211	228	245	262	279	301	322	344	368	391	415	438
		109	192	209	226	243	260	277	299	320	342	366	389	413	436
105	190	207	224	241	258	275	297	318	340	364	387	411	434		

Cooling Mode		16 SEER R410A HP Charge Chart 4 TON(Cooling mode)												
		Outdoor Ambient Temperature(°F)												
		55	60	65	70	75	80	85	90	95	100	105	110	115
Suction Pressure at Large Service Valve(psig)	165			249	265	281	302	324	345	365	385	412	438	465
	161			247	263	279	300	322	343	363	383	410	437	463
	157			245	261	277	298	320	341	361	381	408	435	461
	153		228	243	259	275	296	318	339	359	379	406	433	459
	149		226	241	257	273	294	316	337	357	377	404	431	457
	145		234	239	255	271	292	314	335	355	375	402	429	455
	141	209	223	237	253	269	290	312	333	353	373	400	427	453
	137	207	221	235	251	267	288	310	331	351	371	398	425	451
	133	205	219	233	249	265	286	308	329	349	369	396	423	449
	129	203	217	231	247	263	284	306	327	347	367	394	421	447
	125	201	215	229	245	261	282	304	325	345	365	392	419	445
	121	197	212	227	243	259	280	302	323	343	363	390	417	443
	117	194	210	225	241	257	278	300	321	341	361	388	415	441
	113	190	207	223	239	255	277	298	320	340	360	387	414	439
	109	188	205	221	237	253	275	296	318	338	358	385	412	437
105	186	203	219	235	251	273	294	316	336	356	383	410	435	

Cooling Mode		16 SEER R410A HP Charge Chart 5 TON(Cooling mode)												
		Outdoor Ambient Temperature(°F)												
		55	60	65	70	75	80	85	90	95	100	105	110	115
Suction Pressure at Large Service Valve(psig)	165			254	274	291	309	329	350	370	398	421	447	472
	161			252	271	289	306	327	348	368	396	419	445	470
	157			250	268	287	304	325	346	366	394	417	443	468
	153		229	248	266	285	302	323	344	364	392	415	441	466
	149		227	246	264	283	300	321	342	362	390	413	439	464
	145		225	244	262	281	298	319	340	360	388	411	437	462
	141	205	224	242	260	279	296	317	338	358	386	409	435	460
	137	202	222	240	258	277	294	315	336	356	384	407	433	458
	133	199	220	238	256	275	292	313	334	354	382	405	431	456
	129	197	218	236	254	273	290	311	332	352	380	403	429	454
	125	195	216	234	252	271	288	310	330	350	378	401	427	452
	121	193	214	232	250	269	286	308	328	348	376	399	425	450
	117	191	212	230	248	267	284	306	326	346	374	397	423	448
	113	189	210	228	246	265	282	304	324	344	372	395	421	446
	109	187	208	226	244	263	280	302	322	342	370	393	419	444
105	185	206	224	242	261	278	300	320	340	368	391	417	442	

5. Adjust refrigerant level to attain proper gage pressure.



Add refrigerant if the design liquid line pressure is lower than the chart value.

- Connect gages to refrigerant bottle and unit as illustrated (Figure 40).
- Purge all hoses.
- Open bottle.
- Stop adding refrigerant when liquid line pressure matches the Refrigerant Charging Chart.



Recover refrigerant if the design liquid line pressure is lower than the chart value.

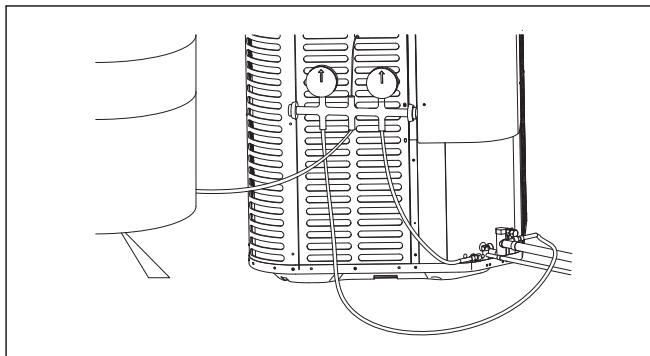



Figure 41

6. Stabilize the system.

- Wait 20 minutes for the system condition to stabilize between adjustments.



When the liquid line pressure match the chart, the system is properly charged.

- Remove gages.
- Replace service port caps to prevent leaks. Tighten finger tight plus an additional 1/6 turn.



Figure 42

7. Record system Information for reference (Table 8).

Record system pressures and temperatures after charging is complete.

Description	Value
Outdoor model number	
Measured Outdoor Ambient	°F
Measured Indoor Ambient	°F
Liquid Gage Pressure	PSIG
Suction Gage Pressure	PSIG

Table 8

15. System operation and troubleshooting

15.1 Compressor crankcase heater (CCH) (Heat pump only)

The crankcase heating start must meet two conditions:

- A. Outdoor temperature < 41°F
- B. At power up or if the compressor has been off for more than 3 hours

The crankcase heating stop must meet the following condition:

Outdoor temperature > 44.6°F or compressor starts.

15.2 Reversing valve (Heat pump only)

Reversing valve energizes at the heating conditions, and cuts off at the cooling condition.

15.3 Protection function (Heat pump only)

- T3 = Outdoor Coil Temperature
T3 > 143.6°F, compressor stops working
T3 < 125.6°F, compressor restarts working
- T4 = Out Ambient Temperature
T4 < 5°F, compressor stops working
T4 > 10.4°F, compressor restarts working
If 55°F ≤ T4 ≤ 115°F, unit can operate in cooling
If 5°F ≤ T4 ≤ 75°F, unit can operate in heating



When T4 < 5°F, the outdoor unit would provide a signal to drive up the heater installed in the indoor unit.

- Discharge temperature protection
Discharge temperature > 275°F, compressor stops working.
Discharge temperature < 194°F, compressor restarts working.
- High pressure protection
High pressure > 638 PSIG, compressor and outdoor fan motor stop working.
High pressure < 464 PSIG, compressor and outdoor fan motor restart working (3 minutes delay necessary).
- Low pressure protection
Low pressure < 21 PSIG, compressor and outdoor fan motor stop working.
Low pressure > 44 PSIG, compressor and outdoor fan motor restart working (3 minutes delay necessary).



In stand-by status, the compressor will not start in low pressure protection. Within 30 minutes, if 4 protection cycles occur. The system will be locked. It will restore after power cycle.

15.4 Protection function (Air conditioner only)

- High pressure protection
High pressure > 638 PSIG, compressor and outdoor fan motor stop working.
High pressure < 464 PSIG, compressor and outdoor fan motor restart working (3 minutes delay necessary).

15.5 Defrost mode (Heat pump only)

Manual defrost mode

When the switch SW3-1 is set to "ON", the system turns to the defrost mode. The defrost mode exits by the logic of shut-down conditions of defrost mode.



Once the manual defrost mode is finished, please turn the switch SW3-1 back to "off".

Start-up conditions of defrost mode

When SW3-3 switch is set to "ON" (Figure 43), the mode will start up in any of the following conditions:

- Compressor operates and T3 < 32°F for a period of 30 minutes.
- T3 < 28.4°F and compressor operates for the first time after connected to the power source.
- When T3 < 28.4°F and the system is on standby for two hours continuously.

When SW3-3 switch is set to "OFF" (Figure 43), the mode will start up in any of the following conditions:

- Compressor operates and T3 < 32°F for a period of 60 minutes.
- T3 < 28.4°F and compressor operates for the first time after connected to the power source.
- When T3 < 28.4°F and the system is on standby for two hours.

Shut-down conditions of defrost mode:

The mode will shut down in any of the following conditions:

- The defrosted time lasts 10 minutes
- T3 ≥ 64.4°F and T4 ≥ 28.4°F
- Compressor stops operating
- T3 ≥ 64.4°F lasts 60 seconds when T4 < 28.4°F

SW3 Switch



SW3 Switch



The location of SW3 Switch in the PCB Board

Figure 43

15.6 Temperature sensor resistance table

Temperature °F	Resistance kΩ	Temperature °F	Resistance kΩ	Temperature °F	Resistance kΩ	Temperature °F	Resistance kΩ
-4	106.73	37	29.87	78	10.00	119	3.69
-3	103.25	38	29.22	79	9.50	120	3.61
-2	99.89	39	28.19	80	9.26	121	3.53
-1	96.65	40	27.39	81	9.03	122	3.45
0	93.53	41	26.61	82	8.81	123	3.38
1	90.53	42	25.85	83	8.59	124	3.30
2	87.62	43	25.12	84	8.38	125	3.23
3	84.83	44	24.42	85	8.17	126	3.16
4	82.13	45	23.73	86	7.97	127	3.10
5	79.52	46	23.07	87	7.78	128	3.03
6	77.01	47	22.42	88	7.59	129	2.96
7	74.58	48	21.80	89	7.40	130	2.90
8	72.24	49	21.20	90	7.22	131	2.84
9	69.98	50	20.61	91	7.05	132	2.78
10	67.80	51	20.04	92	6.88	133	2.72
11	65.69	52	19.49	93	6.72	134	2.67
12	63.65	53	18.96	94	6.56	135	2.61
13	61.68	54	18.44	95	6.40	136	2.56
14	59.78	55	17.94	96	6.25	137	2.50
15	57.95	56	17.45	97	6.10	138	2.45
16	56.17	57	16.98	98	5.96	139	2.40
17	54.46	58	16.52	99	5.82	140	2.35
18	52.80	59	16.08	100	5.68	141	2.30
19	51.20	60	15.65	101	5.55	142	2.25
20	49.65	61	15.23	102	5.42	143	2.21
21	48.16	62	14.83	103	5.30	144	2.16
22	46.71	63	14.43	104	5.18	145	2.12
23	45.31	64	14.05	105	5.06	146	2.08
24	43.95	65	13.68	106	4.94	147	2.03
25	42.64	66	13.32	107	4.83	148	1.99
26	41.38	67	12.97	108	4.72	149	1.95
27	40.15	68	12.64	109	4.61	150	1.91
28	38.97	69	12.31	110	4.51	151	1.88
29	37.82	70	11.99	111	4.41	152	1.84
30	36.71	71	11.68	112	4.31	153	1.80
31	35.64	72	11.38	113	4.21	154	1.77
32	34.60	73	11.09	114	4.12	155	1.73
33	33.59	74	10.80	115	4.03	156	1.70
34	32.61	75	10.53	116	3.94	157	1.66
35	31.67	76	10.00	117	3.85	158	1.63
36	30.76	77	10.00	118	3.77	159	1.60

Table 9

15.7 Electrical data table

Model	AC							HP						
	18	24	30	36	42	48	60	18	24	30	36	42	48	60
Minimum circuit ampacity(A)	10.4	13.7	16.5	19.4	22.5	23.8	29.9	10.4	13.4	16.5	19.4	21.6	22.9	28.8
Maximum circuit protector(A)	15	20	25	30	35	40	50	15	20	25	30	35	35	45

Table 10

STEP 4 - Remove fan motor by removing 5/16" nuts from cover.

STEP 5 - Remove fan blade from motor by removing 1/2" nut and place fan on the ground.

STEP 6 - Reverse removal process to reinstall the fan and motor.

Note: When connecting motor wires be sure to check motor direction.

Damage will occur to condenser unit if you remove 5/16" nuts prior to cover removal.

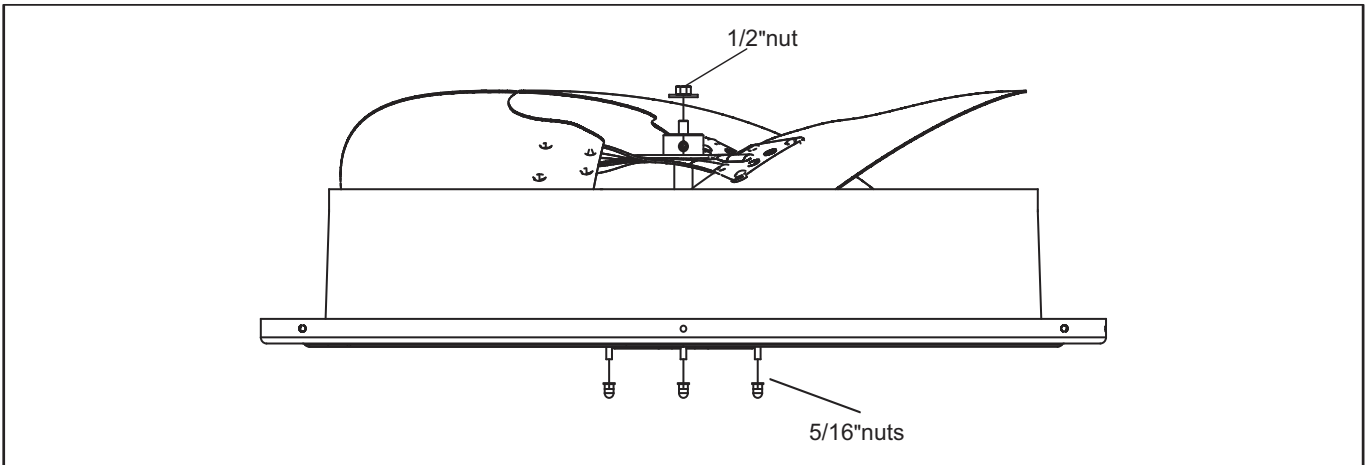

Figure 44

17. Wiring diagrams

17.1 For 18K-48K HP System

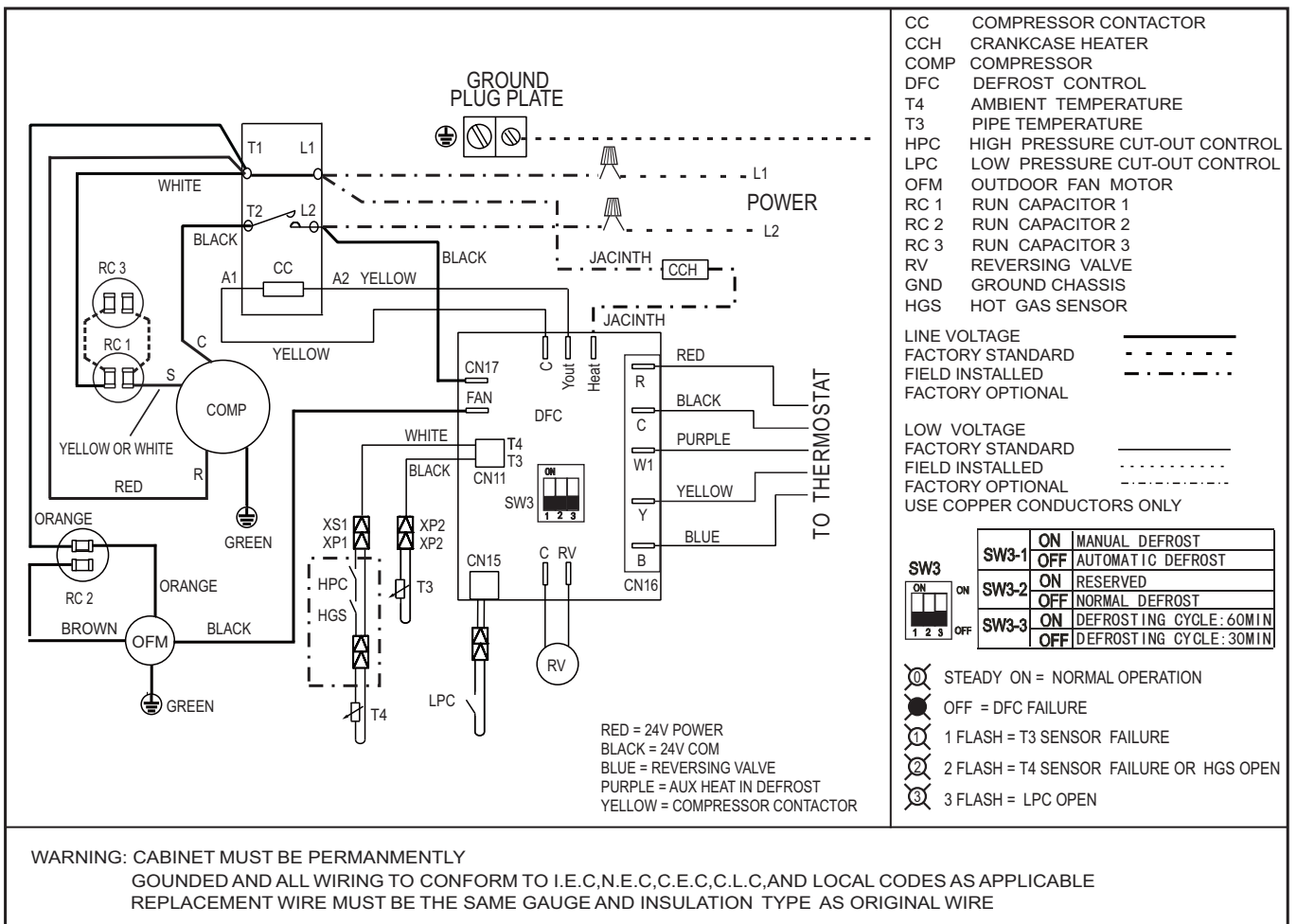

Figure 45

17.2 For 60K HP System

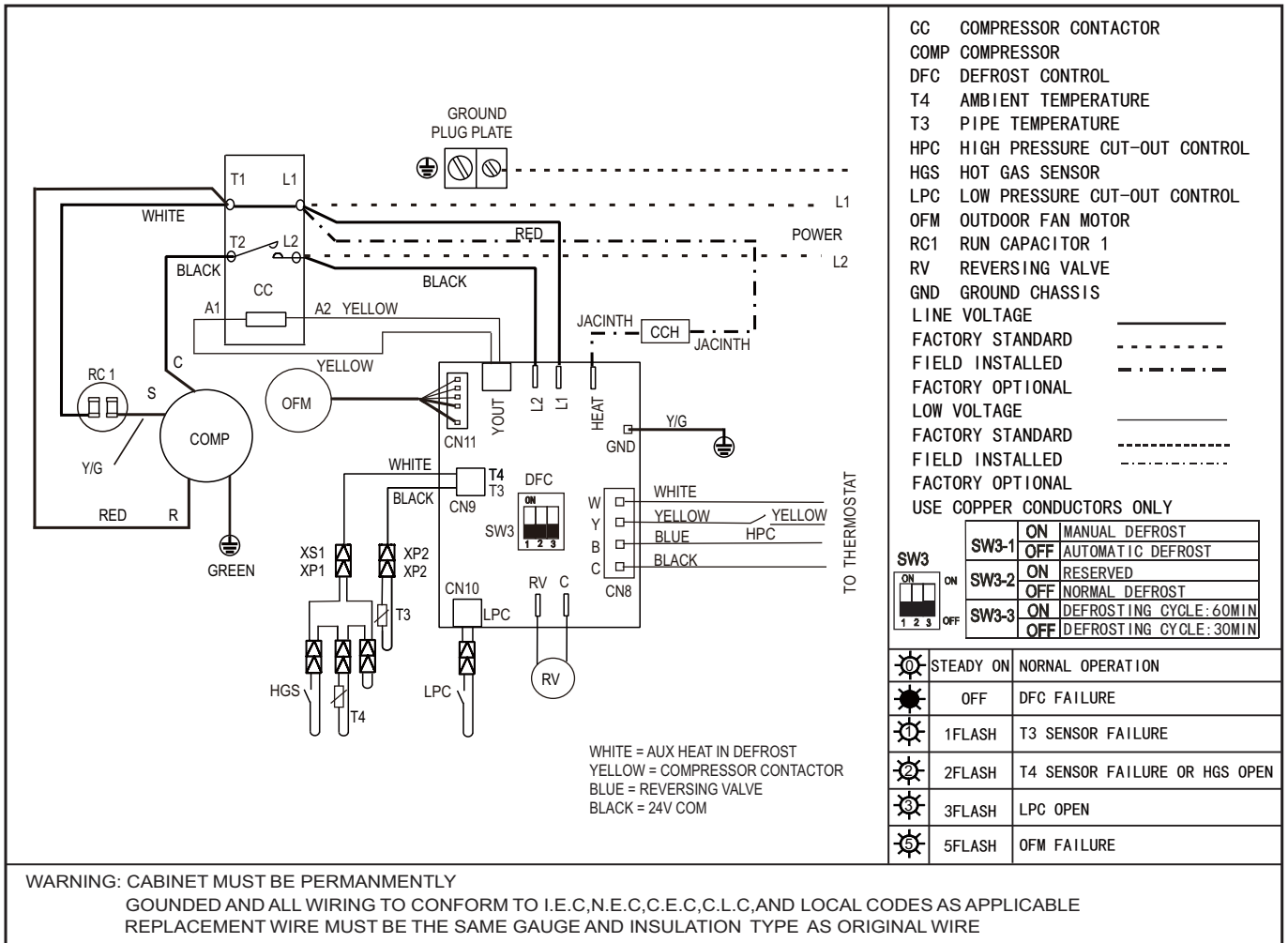

Figure 46

17.3 For 18K-36K AC System

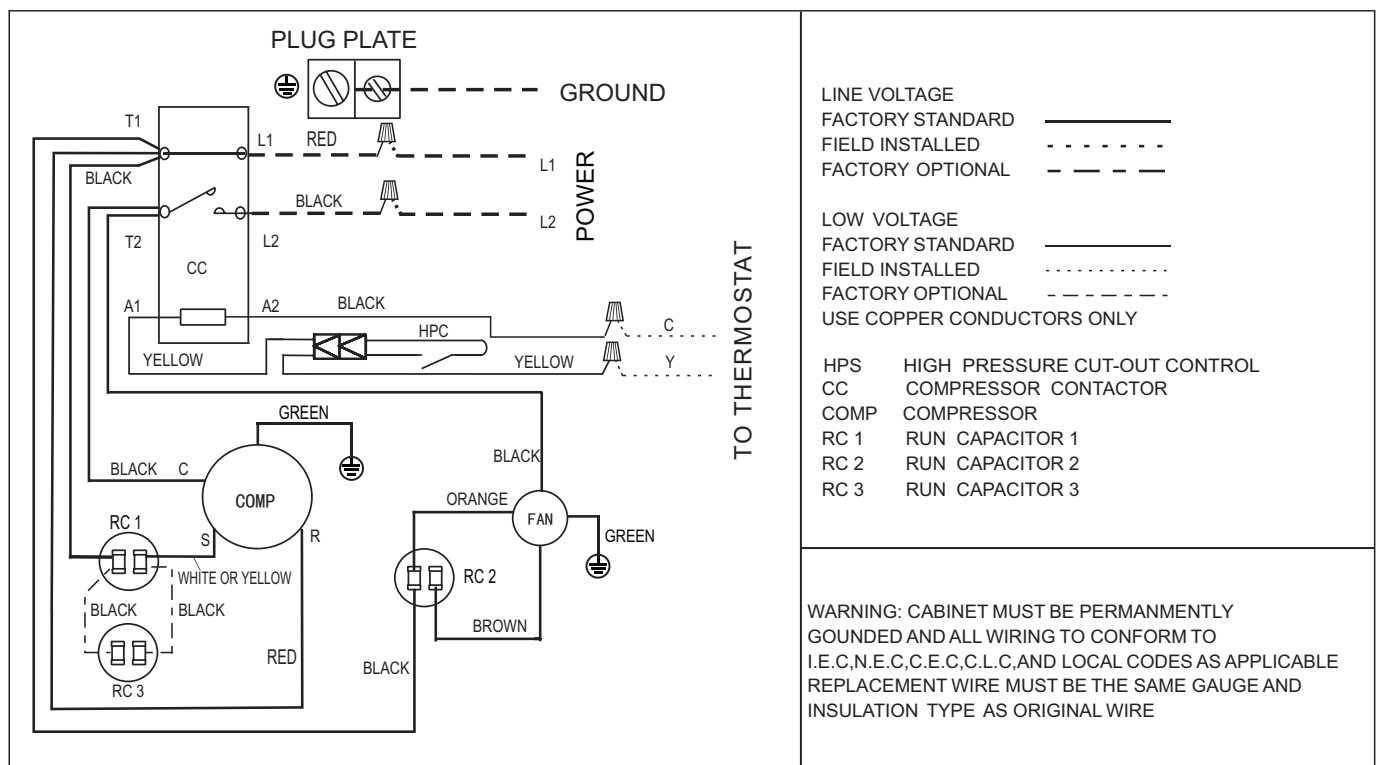

Figure 47

17.4 For 42K-60K AC System

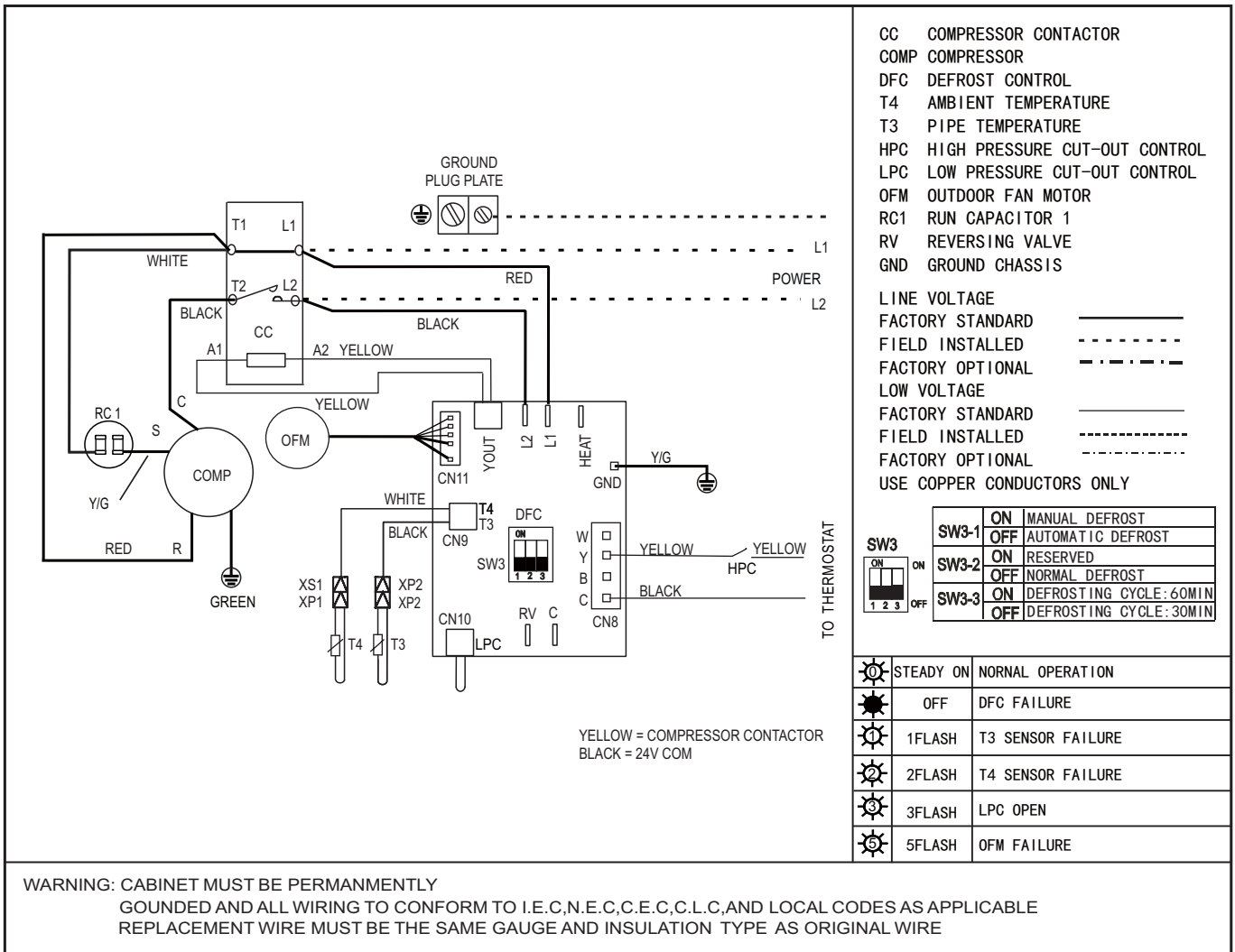

Figure 48

18. Matching table and Checkout Procedures

18.1 Matching table

Condensing Unit	Air Handle/A-Coil	Piston Size/TXV Valve Model	SEER	If Preinstalled Piston Replace Required
J4AC6018A1000AA	J4AH4E36A1B00AA	052	16	YES
J4AC6024A1000AA	J4AH4E36A1B00AA	058	16	YES
J4AC6030A1000AA	J4AH4E36A1B00AA	065	16	YES
J4AC6036A1000AA	J4AH4E60A1C00AA	073	16	YES
J4AC6042A1000AA	J4AH4E60A1C00AA	075	16	YES
J4AC6048A1000AA	J4AH4E60A1C00AA	080	16	YES
J4AC6060A1000AA	J4AH4E60A1C00AA	4AYTXVH3G6000A	15	YES
J4HP6018A1000AA	J4AH4E36A1B00AA	052	16	YES
J4HP6024A1000AA	J4AH4E36A1B00AA	058	16	YES
J4HP6030A1000AA	J4AH4E36A1B00AA	4AYTXVH3G2436A	16	YES
J4HP6036A1000AA	J4AH4E60A1C00AA	070	16	YES
J4HP6042A1000AA	J4AH4E60A1C00AA	4AYTXVH3G4248A	16	YES
J4HP6048A1000AA	J4AH4E60A1C00AA	4AYTXVH3G6000A	16	YES
J4HP6060A1000AA	J4AH6E60A1C00AA	4AYTXVH3G6000A	15	YES

Note: Since the manufacturer has a policy of continuous product and product data improvement, if the system combination you are looking for is not listed, check for the latest version of this document at www.oxboxhvac.com.

18.2 Operational and Checkout Procedures

Final phases of this installation are the unit Operational and Checkout Procedures. To obtain proper performance, all units must be operated and charge adjustments made in accordance with procedures found in the Service Facts of the Outdoor Unit.

After installation has been completed, it is recommended that the entire system be checked against the following list:

- | | |
|--|---|
| 1. Be sure unit suspension(if used) is secure and that there are no tools or loose debris in or around or on top of the unit.....[] | 5. Check all duct outlets; they must be open and unrestricted. [] |
| 2. Properly insulate suction lines and fittings.....[] | 6. Check drain lines and be sure all joints are tight..... [] |
| 3. Properly secure and isolate all refrigerant lines... [] | 7. Be sure that a return air filter is installed..... [] |
| 4. Verify that all electrical connections are tight.[] | 8. Operate complete system in each mode to verify proper performance. Verify operation of supplementary electric heater. [] |