

SUBMITTAL DATA: MSY-GL12NA-(U1)(U2) & MUY-GL12NA-U2

12,000 BTU/H WALL-MOUNTED AIR-CONDITIONING SYSTEM

Job Name:	Location:	Date:
Purchaser:	Engineer:	
Submitted to:	For <input type="checkbox"/> Reference <input type="checkbox"/> Approval <input type="checkbox"/> Construction	
System Designation:	Schedule No.:	



Wireless Remote Controller

ACCESSORIES:
Indoor Unit

Anti-Allergy Enzyme Filter (MAC-408FT-E)

Outdoor Unit

Windscreens (ME-FR-12-17)

Note: Mitsubishi Electric (MESCA) supports the use of only MESCA supplied and approved Snow Guard / Wind Deflectors / Windscreens and accessories for proper functioning of the unit(s). Use of non-MESCA supported Snow Guard / Wind Deflectors / Windscreens and accessories will affect warranty coverage.

Controls

Wireless Controller (MHK1)

Wired Remote Controller PAR-40MAA (Requires MAC-334IF-E)

Thermostat Interface (PAC-US444CN-1)

SPECIFICATIONS:

Rated Conditions (Capacity / Input)		
Cooling ¹	Btu/h / W	12,000 / 920

Capacity Range	Minimum	Maximum
Cooling ¹	Btu/h / W	1,500 / 100 13,600 / 1,300

NOTE: Test conditions are based on AHRI 210/240.

1: Rating conditions (Cooling) — Indoor: 80°FDB, 67°FWB, Outdoor: 95°FDB, (75°FWB)

Operating Conditions (Outdoor Intake Air Temp.) (Max./ Min.)	
Cooling ²	115 F (46° C) DB / 14° F (-10° C) DB

² Applications should be restricted to comfort cooling only; equipment cooling applications are not recommended for low ambient temperature conditions.

AHRI Efficiency Ratings	
SEER / EER	23.1 / 13.0

Energy Star [®]
Yes

ENERGY STAR products are third-party certified by an EPA-recognized Certification Body.

Electrical Power Requirements	208 / 230V, 1-Phase, 60 Hz
-------------------------------	----------------------------

Minimum Circuit Ampacity (MCA) *		
Indoor / Outdoor (RBS)	A	1 / 7 (15A - Recommended Breaker Size)

***All electrical work shall comply with National (CEC) and local codes and regulations.**

Indoor Unit		
Blower Motor (ECM)	F.L.A.	0.76
Blower Motor Output	W	30
SHF / Moisture Removal		0.740 / 2.5 pt./h
Field Drainpipe Size O.D.	In.(mm)	5/8 (15)

Outdoor Unit		
Compressor		DC INVERTER-driven Twin Rotary
Fan Motor (ECM)	F.L.A.	0.50

Airflow Rate (Quiet - Lo - Med - Hi - Super Hi)			
Indoor	DRY	CFM (L/sec)	145-170-237-321-399 (68-80-112-152-188)
	WET		109-134-201-286-364 (51-63-95-135-172)
Outdoor			639 / 1102 (301 / 520)

Sound Pressure Level (Quiet - Lo - Med - Hi - Super Hi)			
Indoor	Cooling	dB(A)	19-22-30-37-45
Outdoor	Cooling		49

External Dimensions		
Indoor (H x W x D)	In.(mm)	11-5/8 x 31-7/16 x 9-1/8 (295 x 798 x 232)
Outdoor (H x W x D)		21-5/8 x 31-1/2 x 11-1/4 (550 x 800 x 285)

Net Weight		
Indoor	Lbs.(kg)	22 (10)
Outdoor		81 (37)

External Finish	
Indoor	Munsell 1.0Y 9.2 / 0.2
Outdoor	Munsell No. 3Y 7.8 / 1.1

Refrigerant	R410A; 2 lb. 9 oz.
-------------	--------------------

Refrigerant Piping (Flared)		
Liquid (High Pressure)	In.(mm)	1/4 (6.35)
Gas (Low Pressure)		3/8 (9.52)
Max. Total Refrigerant Pipe Length (Height Diff.)	Ft. (m)	40 (12)
Max. Total Refrigerant Pipe Length (Length.)		65 (20)

Specifications are subject to change without notice

DIMENSIONS: MSY-GL12NA-(U1)(U2) & MUY-GL12NA-U2

Unit: in. (mm)

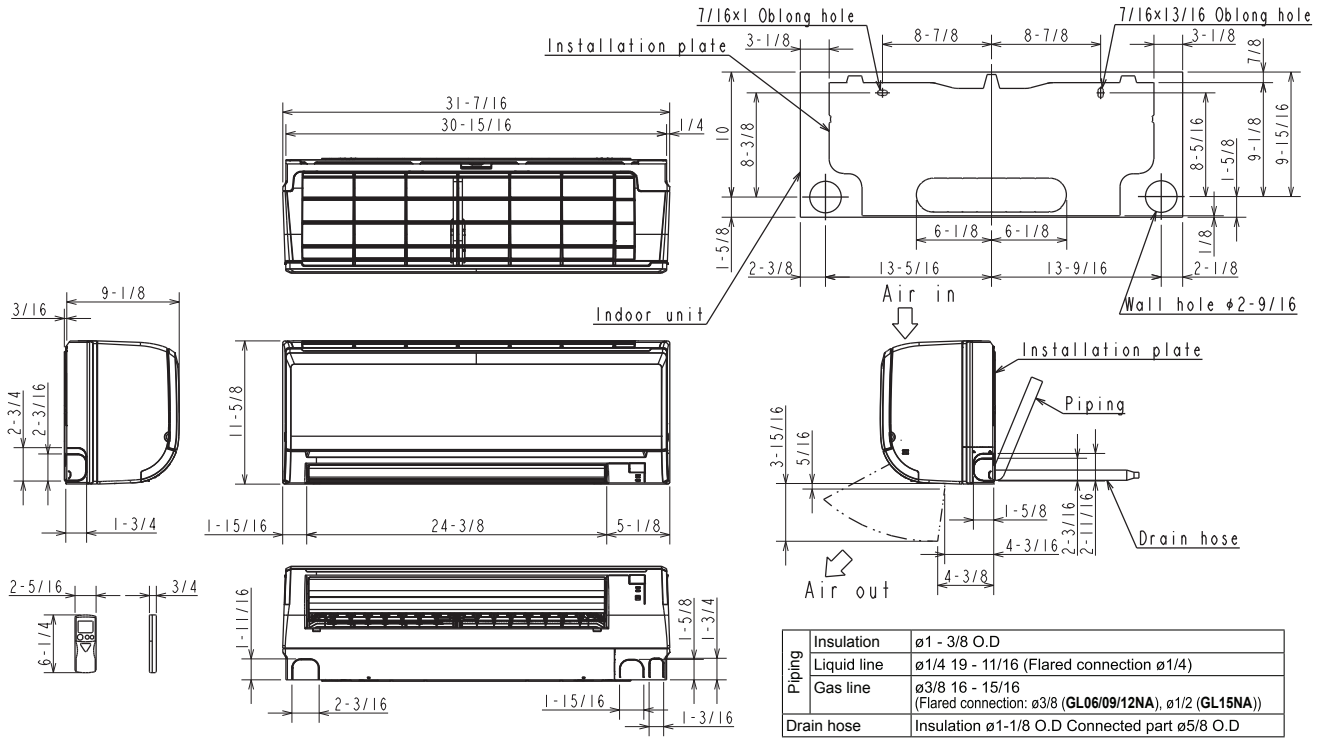

REQUIRED SPACE

Unit: in. (mm)

*1 4 in. (100 mm) or more when front and sides of the unit are clear

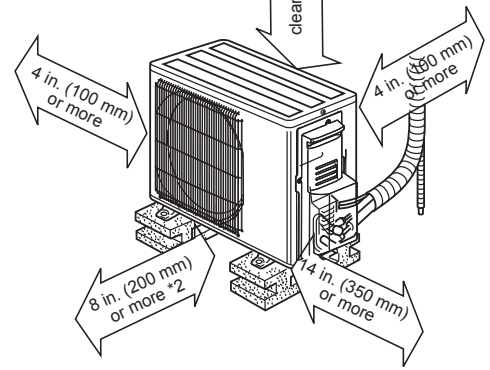

*2 When any 2 sides of left, right and rear of the unit are clear

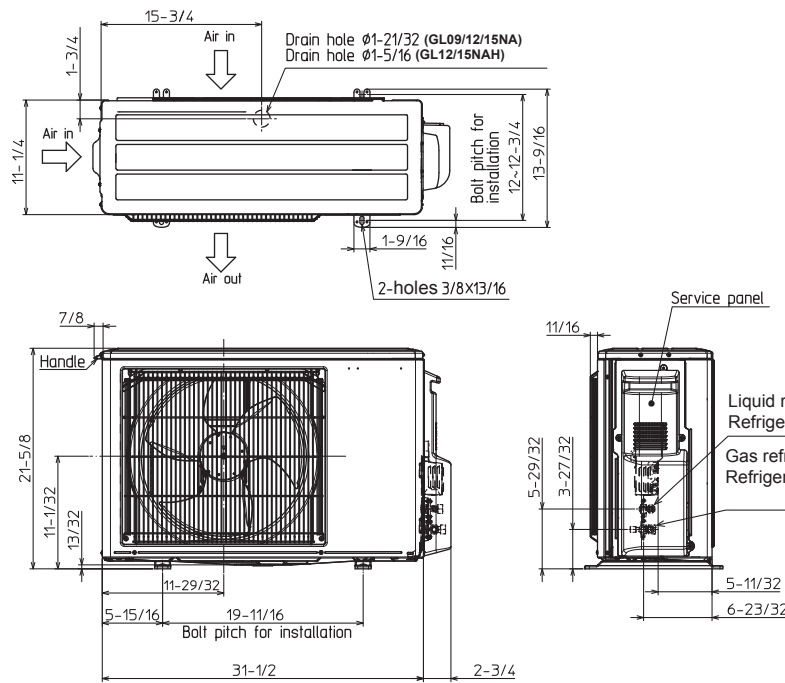

Should this document be altered or changed without MESCA's permission, it becomes null and void. MESCA assumes no responsibility for any consequences in such cases.