

MODEL	PUMP MOTOR				
	HP	PH	HZ	Volts	Amps
H2H425-E01	¾	1	60	240	5.2

ITEM #	DESCRIPTION
1	1-1/2" BULKHEAD FOR FILL W/FLOAT VALVE
2	1/2" BULKHEAD FOR TEST LINE
3	3/4" BULKHEAD FOR OVERFLOW
4	TEST LINE
5	PRESSURE SWITCH
6	SUCTION SHUT-OFF VALVE
7	PRESSURE GAUGE
8	DISCHARGE SHUT-OFF VALVE
9	TANK DRAIN
10	DISCHARGE CHECK VALVE
11	CONTROL PANEL (OPTIONAL)
12	RISER MANIFOLD
13	SYSTEM DRAIN

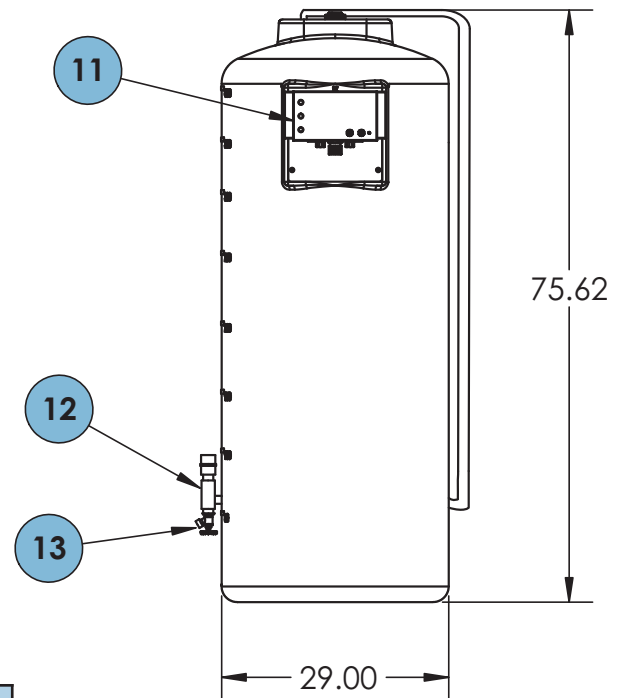
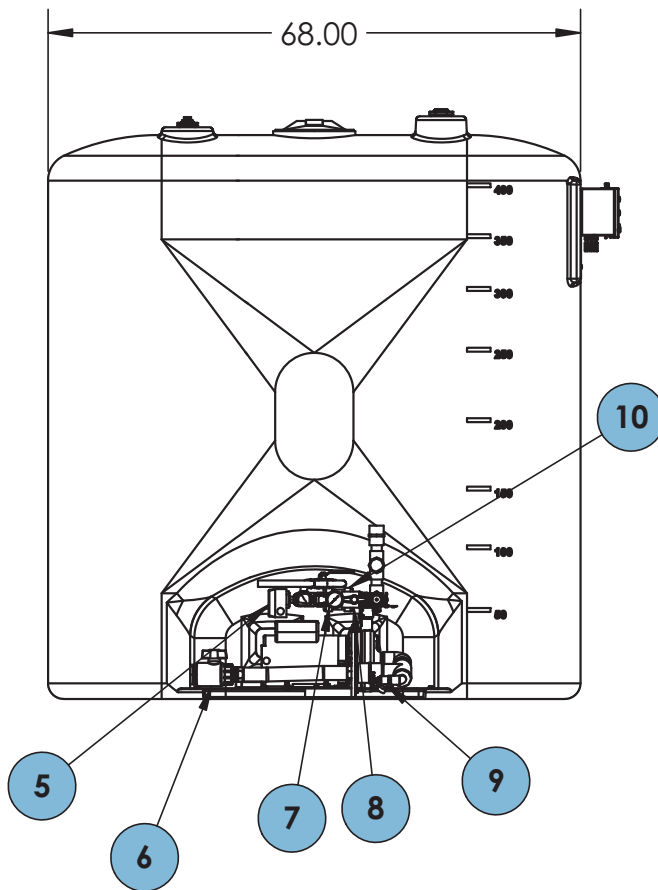
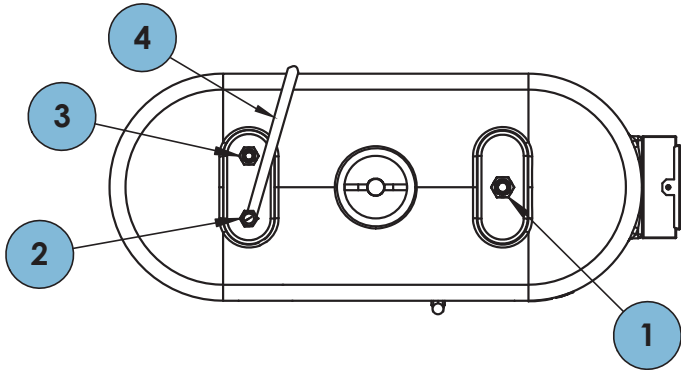

PERFORMANCE				
GPM	20	25	30	35
PSI	26	24	20	18