



SERIES: B200T (1/4" - 4")

2-PC. SCREWED END BALL VALVE

Brass

DESIGN FEATURES:

- Full port, 1/4"~4" (DN8-DN100)
- **W.P. :**
 - » 1/4" - 2": **600 WOG**
 - » 2-1/2" - 4": **400 WOG**
- U.L. Listed
- Solid Ball
- NSF/ANSI 61-8
- CSA-ANSI Z21.15
- CGA9.1, ASME B16.44, CGA CR91-002
- Thread type:
 - » ASME B1.20.1 (NPT)
 - » DIN2999 & BS21
 - » ISO7/1 & EN10226
- Blow-out proof stem
- Locking device (1/4 - 2" only)

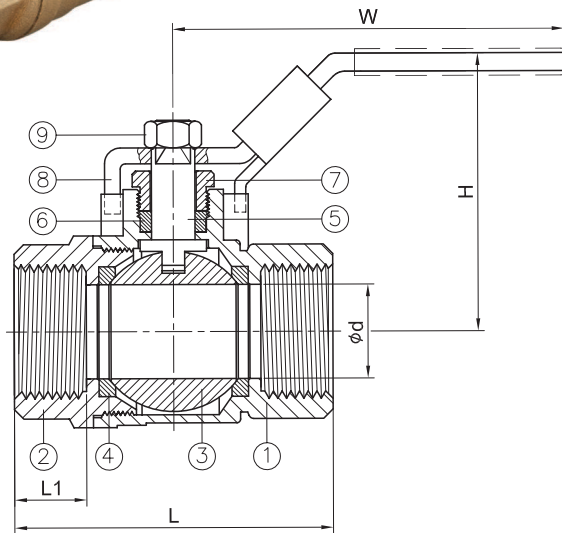

ITEM	PARTS	MATERIAL
		B200T
1	BODY	BRASS
2	CAP	
3	BALL	
4	SEAT	PTFE
5	STEM	BRASS
6	PACKING	PTFE
7	GLAND	BRASS
8	HANDLE	NICKEL PLATING STEEL
9	STEM NUT	BRASS PLATING STEEL

DN	d	L	L1	H	W	NPT THREAD	Weight (kg)
8	10.0	44.6	11.6	47.8	90.0	1/4"	0.4
10	10.0	44.6	11.6	47.8	90.0	3/8"	0.4
15	14.8	52.0	13.2	53.1	90.0	1/2"	0.4
20	19.0	60.0	14.3	56.8	96.0	3/4"	0.7
25	24.0	70.0	16.0	67.8	115.0	1"	1.1
32	32.0	84.0	18.0	77.50	115.0	1-1/4"	1.6
40	40.0	93.0	18.2	88.5	140.0	1-1/2"	2.4
50	50.0	106.2	19.0	97.5	140.0	2"	3.4
65	64.0	136.6	26.0	121.0	220.0	2-1/2"	9.0
80	74.0	153.4	28.0	129.0	220.0	3"	12.0
100	99.0	187.6	31.0	149.0	244.0	4"	18.0

unit: mm

NPS	d	L	L1	H	W	NPT THREAD	Weight (lb)
1/4"	0.39	1.76	0.46	1.88	3.54	1/4"	0.7
3/8"	0.39	1.76	0.46	1.88	3.54	3/8"	0.7
1/2"	0.58	2.05	0.52	2.09	3.54	1/2"	1.0
3/4"	0.75	2.36	0.56	2.24	3.78	3/4"	1.5
1"	0.95	2.76	0.63	2.67	4.53	1"	2.4
1-1/4"	1.26	3.31	0.71	3.05	4.53	1-1/4"	3.5
1-1/2"	1.58	3.66	0.72	3.48	5.51	1-1/2"	5.3
2"	1.97	4.18	0.75	3.84	5.51	2"	7.4
2-1/2"	2.52	5.38	1.02	4.76	8.66	2-1/2"	19.8
3"	2.91	6.04	1.10	5.08	8.66	3"	26.0
4"	3.90	7.39	1.22	5.87	9.61	4"	40.0

unit: in