

TOP VIEW

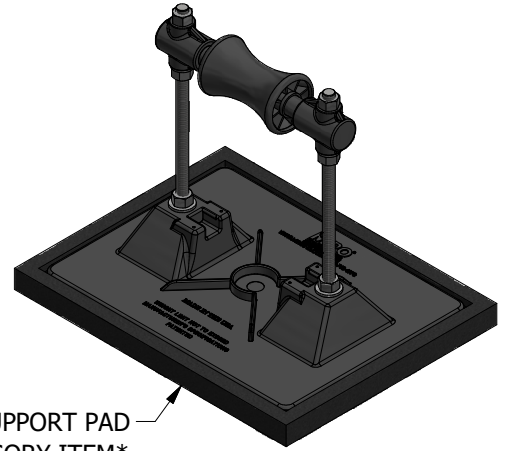

ISOMETRIC VIEW

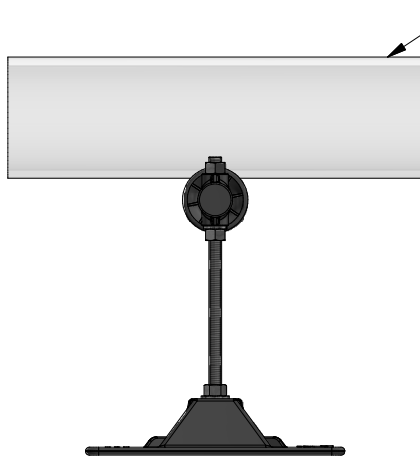

SIDE VIEW

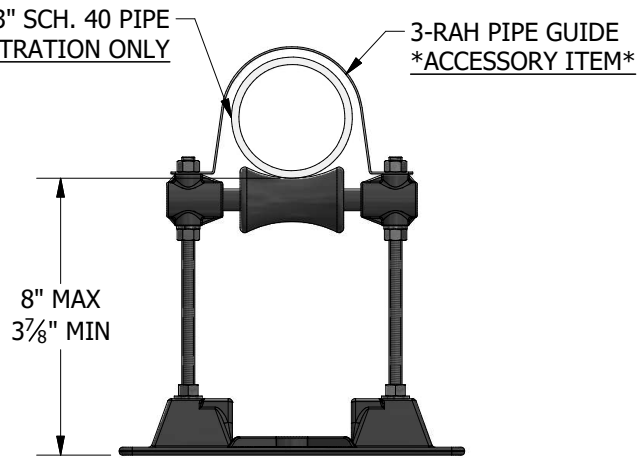

END VIEW

ACCESSORIES

- Refer to 3-RAH Pipe Guide specification for available sizes.
- 7 1/2 " x 10" Support pad
- Eternabond® 2-sided tape

PRODUCT DESCRIPTION

A "roller-bearing" pipe support used to support roof-mounted gas pipes, electrical conduit, solar piping and other mechanical piping. Unique design absorbs thermal expansion and contraction of pipes thus preventing damage to the roof membrane. Pipes rest on a self-lubricating polycarbonate resin axle and roller.

KEY INFORMATION

- Optimally designed for a 3" pipe.
- Maximum pipe OD (with insulation) is 5-1/2".
- Adjustable from the factory set maximum height of 8" down to a minimum height of 3-7/8".
- Maximum load is 172 lbs. (3.0 psi) Make certain each pipe support is properly elevated to evenly distribute weight at all pipe support locations.
- Unit weight: 1.72 lbs.
- 12 per case, 21 lbs., (DW=29 lbs.)
- Recommended spacing is not to exceed 10' centers depending upon the load.
- Base Material: Polycarbonate
- Roller, Axle and Collar Material: Polycarbonate
- 3/8" all-thread is stainless steel
- All other metal parts are hot-dip galvanized

The information contained in this drawing is the sole property of MIRO Industries, Inc. Any reproduction in part or as a whole without written permission of MIRO Industries, Inc. is prohibited.

DATE:
JAN 2019

3-RAH-8