

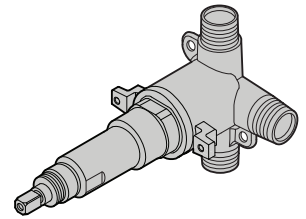





2DIVBODYSRT
Dual Outlet Diverter

Operation & Maintenance Manual



<p>Model Numbers</p> <p><input type="checkbox"/> 2DIVBODYSRT <i>Dual Outlet Diverter</i></p>	<p>Specification</p> <p>Dual outlet diverter valve features shared functionality. Inlet and outlet connections are both 1/2" male IPS & 1/2" female sweat. Components made from lead free metal construction.</p> <div style="text-align: right;">   </div>
<p>Warranty</p> <p>Limited Lifetime - to the original end purchaser in consumer/residential installations. 5 Years - for industrial/commercial installations. Refer to www.symmons.com/warranty for complete warranty information.</p>	<p>Compliance</p> <p>-ASME A112.18.1/CSA B125.1</p> <div style="text-align: right;">  </div>

Dimensions

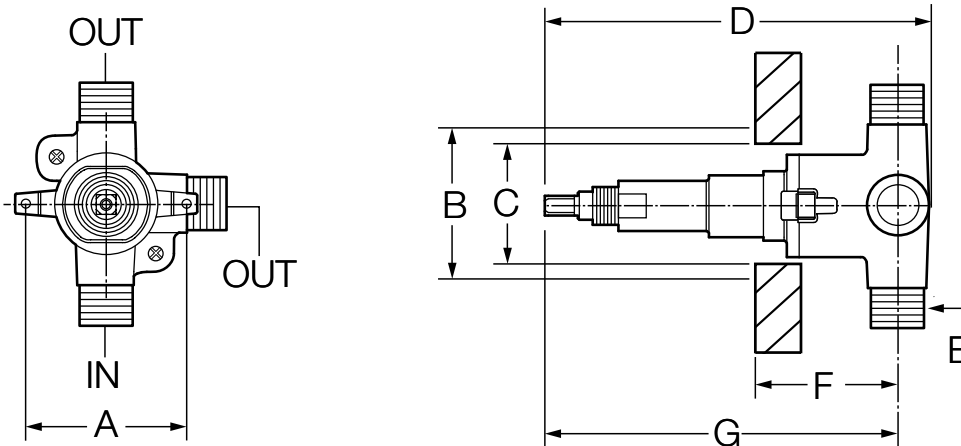

Measurements	
A	2-5/8", 67 mm
B	Screwless Escutcheons Hole Size Min. Ø 3", 76 mm Max. Ø 3-1/4", 83 mm
C	Screw Escutcheons Hole Size Min. Ø 1-3/4", 44 mm Max. Ø 2", 51 mm
D	5-1/4", 133 mm
E	(3x) 1/2" male IPS & (3x) 1/2" sweat
F	See note 1
G	4-7/8", 124 mm

Notes:

- 1) Figure is determined by style of trim attached to shower valve. See rough-in dimension drawing for shower valve application with diverter valve.
- 2) Dimensions subject to change without notice.



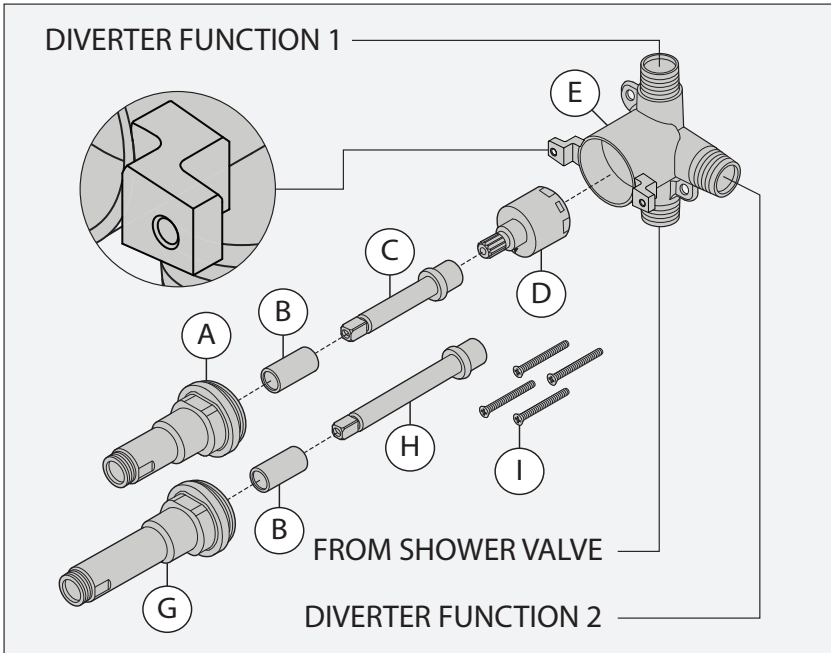

Parts Breakdown

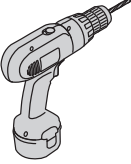

Replacement Parts

Item	Description	Part Number
A	Cap Assembly	RTS-DIVCAP-SRT
C	Cartridge Extender	RTS-DIVEXT-SRT
D	Cartridge Retaining Sleeve	RTS-2DIV
B	Spacer	RTS-DIV-1EXT
G	1" Cap Extender	
H	1" Cartridge Extender	
I	4" Mounting Screws	

Tools Required

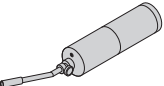
Adjustable Wrench	
Drill (optional)	
Plumber Tape	
Safety Glasses	
Solder	
Torch	

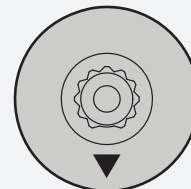

Important:
Cartridge (D)
must be installed
with arrow
facing down.

Installation



Important: Do not plug outlet ports. Do not use diverter as shut-off valve.



Important: Do not expose diverter valve to heat for longer than 2 minutes when sweating in copper tubing. Doing so may damage the internal components of the valve and will void the product warranty.

Note: Diverter valve can be installed in wall with shower valve or in an adjoining wall to shower valve.

1) Reference rough-in dimension for shower application with diverter for proper installation of diverter valve.

2) Shut-off water supplies.

3) Position diverter valve (E) so port marked **IN** is facing down.

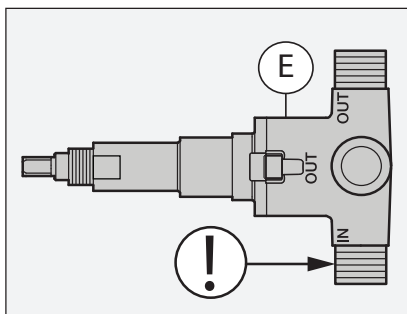

4) Secure stringer mounts on diverter valve (E) to wood blocking for support.

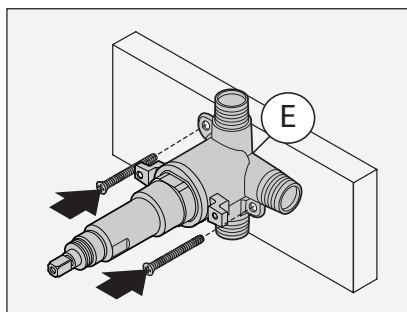

Note: Securing stringer mounts is necessary for applications where PEX, or other non rigid tubing, is used to install diverter valve.

5) Sweat 1/2" copper tubing from inlet port on diverter valve to water source. Sweat 1/2" copper tubing from outlet ports to desired accessories.

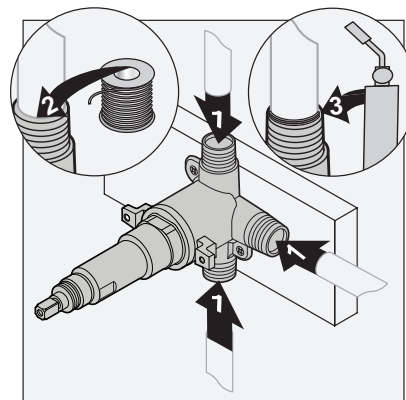

Optional: Apply plumber tape to male IPS threads on the inlet and outlet ports of diverter valve. Install 1/2"-14 NPT copper fittings to the inlet and outlet ports. Connect outlets to desired accessories.

6) Turn on water supplies to flush plumbing lines free of debris. Check for leaks.

Operation

1) Cartridge is factory set to divert to function 1.

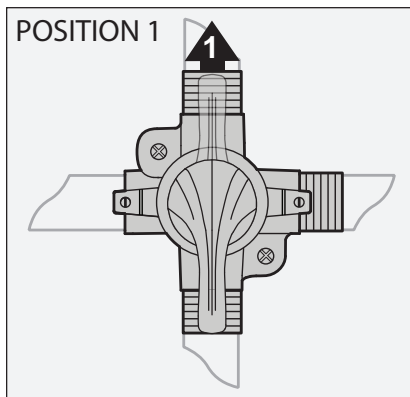

2) Turn handle to position 2 to divert to function 2.

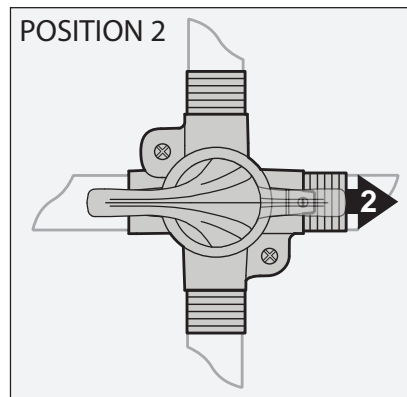

3) Turn handle to position 3 to share functions 1 and 2.

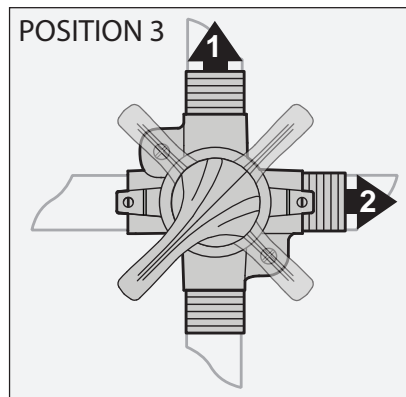

Note: Additional handle positions for same output are illustrated.

Maintenance (Cartridge Replacement)

- 1) Remove cap assembly (A) from diverter valve by turning counterclockwise. Remove cartridge extender (C) and cartridge (D). For diverter valves purchased before November 2016, remove retaining sleeve (F) from diverter valve.

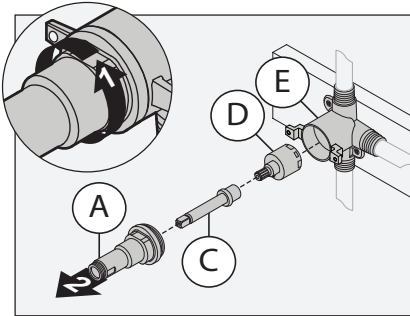

Note: Spacer (B) will be seated inside cap assembly (A).

- 2) Inspect cartridge for debris. Replace cartridge if necessary.

- 3) Orient new cartridge (D) with arrow facing down. Align pegs on cartridge (D) with indents inside diverter valve (E).

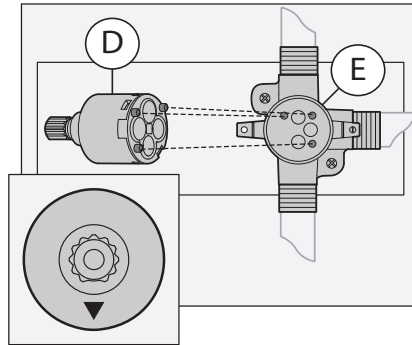

Note: For diverter valves purchased before November 2016, retaining sleeve (F) must be inserted flush into diverter valve (E) before installing cartridge (D).

- 4) Align spindle extender (C) with broach on cartridge (D). Install spindle extender (C) and cap assembly (A) to cartridge (D). Secure cap assembly (A) by turning clockwise.

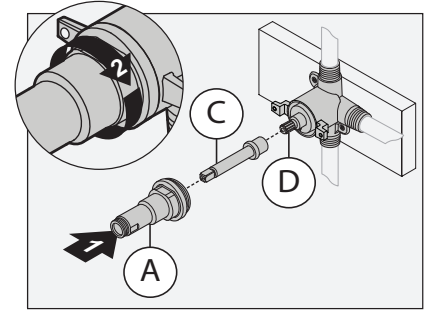

Notes:

- 1) Use caution not to dislodge cartridge from valve body when installing cap assembly (A).
- 2) Tighten cap assembly (A) to 75 ± 5 lbf-in of torque.

Troubleshooting Chart

Problem	Cause	Solution
Diverter valve will not divert water.	Foreign matter in water supply may cause blockages in plumbing lines and the diverter valve cartridge.	Remove cartridge from diverter valve. Flush lines free of foreign matter. Inspect cartridge for debris. Replace cartridge if necessary.
Water is leaking from the face of the diverter valve.	Cap assembly is not fully sealed to diverter valve.	Remove cap assembly. Inspect threads for debris. Reinstall cap assembly to diverter valve at 75 ± 5 lbf-in of torque.
Diverter trim will not install to diverter valve.	Diverter valve body rough-in is too deep.	Use RTS-DIV-1EXT to extend diverter stem 1 inch.

⚠ WARNING: This product can expose you to chemicals including lead, which is known to the state of California to cause cancer, birth defects, or other reproductive harm. For more information, go to www.P65Warnings.ca.gov.