

SPECIFICATIONS

FIGURE 78957

STRUT ACCESSORIES



U-SHAPED SADDLE WASHER

FEATURES

- Available in 1/4", 3/8", 1/2" & 5/8"
- Curved to fit 1-5/8" wide strut channel
- Made in the USA



PRODUCT SPECIFICATIONS

Material Specifications and Finishes

Carbon Steel – ASTM A1011-00 SS GR 33 or ASTM A1011-00CS Type B

Z: Electro-Galvanized. Electroplating deposits zinc on the surface of the steel by electrolysis from a bath of zinc salts. Recommended for relatively dry indoor use. This is the standard coating for most FNW strut products. Thickness of applied zinc is between 0.2 mils to 0.5 mils [5.1 μm to 12.7 μm]. Coatings on FNW electro-galvanized products meet ASTM B633 SC1 Type III.

G: Green Powder Coat. A polyester powder coating is electrostatically applied after fabrication. The powder is then baked on creating a 1.38 to 1.77 mil [35 – 45 μm] thick coating. The hardness of this coating meets ASTM D-3363-74, the impact rating meets ASTM D-2794-93 and the gloss meets ASTM D-523-85. This creates a coating that is resistant to chipping, peeling and corrosion. Available in many colors by special order.

HD: Hot Dip Galvanized After Fabrication. Fabricated product is dipped in molten zinc and is completely covered on all surfaces. Recommended for outdoor use. Coatings on FNW HD products meet ASTM A123/153. The zinc coating is typically 2.6 mils [66.0 μm] or 1.5 oz. per square foot [0.46 kg per square meter] per side.

S4: 304 Stainless Steel – ASTM A240 (Type 304)

S6: 316 Stainless Steel – ASTM A240 (Type 316), 316 Stainless Steel Nuts – ASTM A276-03

Y: Yellow Zinc Dichromate. A 0.5 mil [12.7 μm] electro-galvanized zinc plating meeting ASTM B633 SC1 Type III is applied to the surface of the metal. Yellow dichromate is applied over the zinc. This results in a yellowish gold appearance and acts as a nonporous barrier sealant that is corrosion resistant and can be painted.

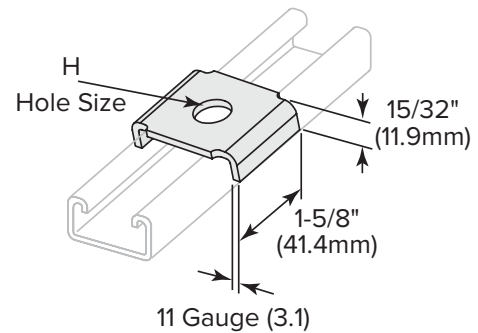
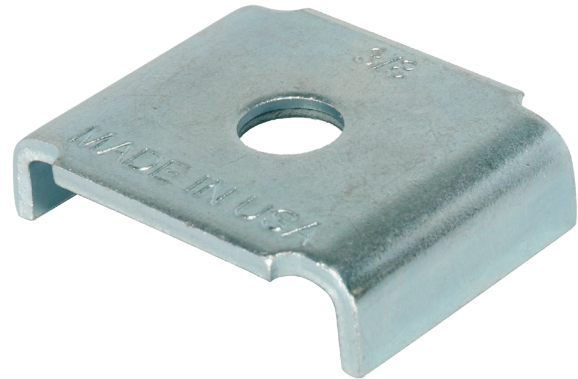

Catalog Number	Bolt Size		H (Hole Size)		Weight	
	in.	mm	in.	mm	lbs	kg
FNW789570Z0025	1/4	6	5/16	7.9	0.14	0.064
FNW789570Z0037	3/8	10	7/16	11.1	0.14	0.064
FNW789570Z0050	1/2	13	9/16	14.3	0.13	0.059
FNW789570Z0062	5/8	16	11/16	17.4	0.13	0.059