

TYPICAL INSTALLATION

Z536-C



15-3/8 [391] DIAMETER HEAVY-DUTY PARKING DECK DRAIN W/ SUPPORT FLANGE & UNDERDECK CLAMP

Dimensional Data (inches and [mm]) are Subject to Manufacturing Tolerances and Change Without Notice

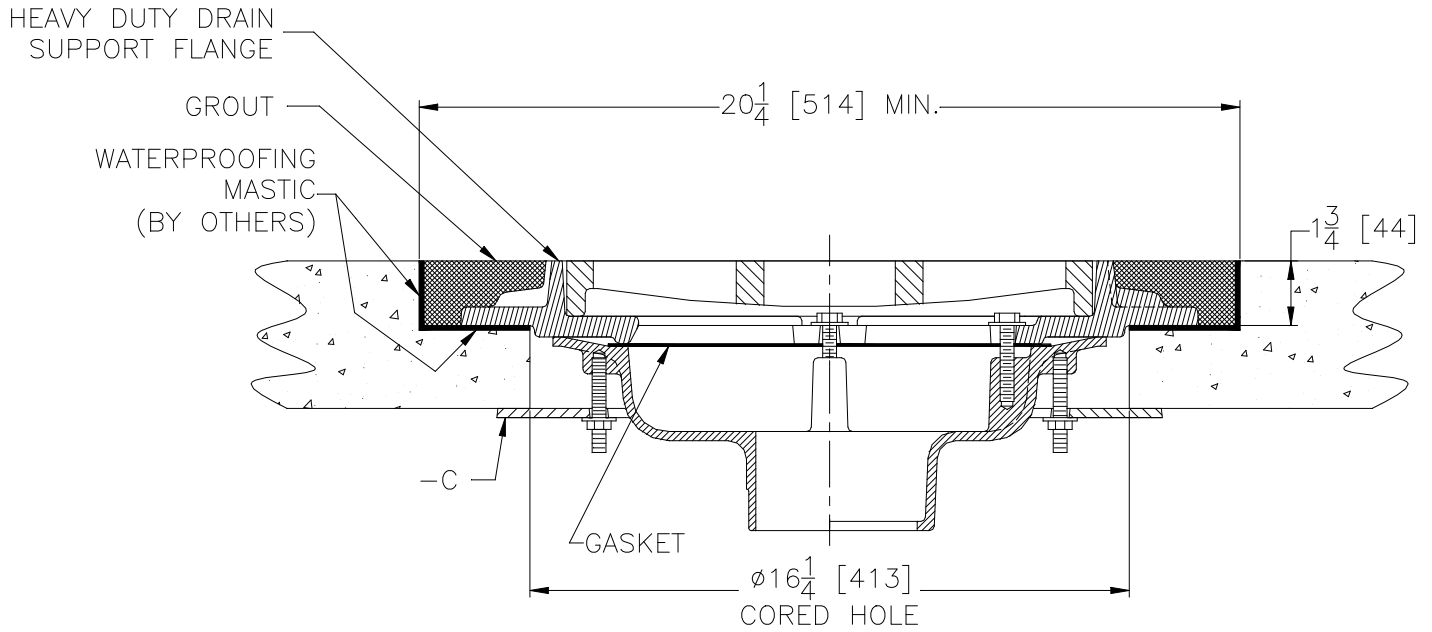

Z536-C PARKING DECK DRAIN

Parking Deck Drains are designed for economical installation in precast construction. Wide heavy-duty flange allows shallow core drilling or boxing out and maximum strength at load bearing surface. Heavy-duty non-tilt grate is standard and underdeck clamp (-C) is available to securely fasten drain body to deck from underside. For other available parking deck drains see Z533, Z534, Z535, and Z537.

⚠ WARNING: Cancer and Reproductive Harm - www.P65Warnings.ca.gov

⚠ ADVERTENCIA: Cáncer y daño reproductivo - www.P65Warnings.ca.gov

⚠ AVERTISSEMENT: Cancer et effets néfastes sur la reproduction - www.P65Warnings.ca.gov

Zurn Industries, LLC | Specification Drainage Operation

1801 Pittsburgh Avenue, Erie, PA U.S.A. 16502 · Ph. 855-663-9876, Fax 814-454-7929

In Canada | Zurn Industries Limited

3544 Nashua Drive, Mississauga, Ontario L4V 1L2 · Ph. 905-405-8272, Fax 905-405-1292

www.zurn.com

Rev. C
Date: 04/09/2018
C.N. No. 139857
Form No. FD39