

Sunpak Infrared Heater

-Two Stage Hardwired

Supplementary Instructions for

Model S34-TSH

These instructions are designed to be used in conjunction with Sunpak Installation, Operation & Maintenance Manual (P/N 65132). Should you have any questions regarding these instructions or need a copy of the Sunpak Manual, please contact the factory.

Infrared Dynamics, Inc
3830 Prospect Avenue
Yorba Linda, CA 92886
Tel: (888) 317-5255
[www. Infradyne.com](http://www.Infradyne.com)

Installer – Please take the time to read and understand these instructions as well as the Sunpak Installation manual P/N 65132. Copies of these instructions are available on our website or from the manufacturer. Installer must give a copy of this manual to the owner.

Owner – Keep this manual in a safe place in order to provide your service provider with necessary information.

Sunpak S34-TSH

The Sunpak S34-TSH outdoor heater provides radiant heat with both a high and low heat setting. This non-remote control heater is hardwired making it easily adaptable for single and multi-heater installations where a central system control panel is used.

The Sunpak S34-TSH two stage heaters are easily controlled using a duplex switch such as the Leviton switch No. 5634. The switch must be wired according to our diagram to work properly. A 24 VAC Class 2 transformer is required to supply electrical to heater.

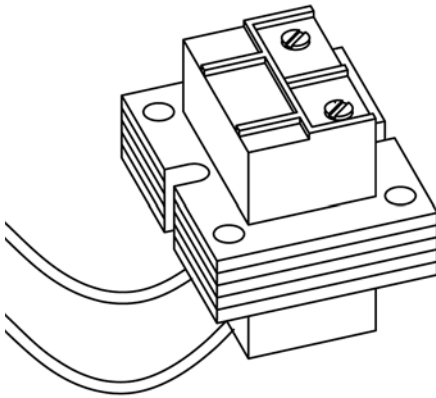

Figure 1. A 24 VAC 20 VA Class 2 Transformer with a UL/CSA listing is required for each heater. Available from your local distributor. **Transformer is to be supplied by installer.**

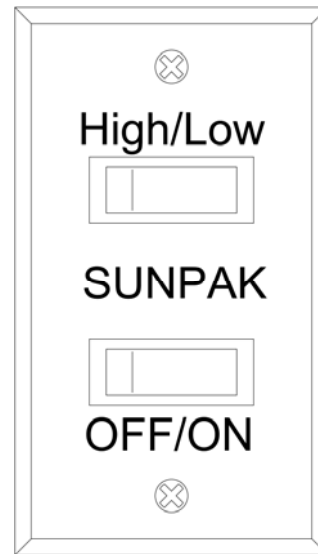

Figure 2 Dual switch panel controls OFF/ON and HI/LO functions on Sunpak Module S34-TSH.

Initial Power-up of Sunpak S34-TSH

Once the heater has been mounted properly, the clearance from combustibile material verified and the gas and electric power hooked up you are ready to POWER-UP. See Sunpak Instruction #65132 for details.

POWER-UP

Always start the Sunpak heater on the high setting. Once the heater is at full heat, the low setting can be used.

Note: There is a 5 second delay before the heater powers up.

Press the ON switch to start the ignition sequence. The spark will initiate within 5 seconds followed by the ignition of the pilot. If the pilot fails to ignite after 10 seconds the gas and spark will shut off. The pilot will try to light 3 times before lockout.

NOTE: If the burner fails to ignite you must wait 5 minutes before attempting to relight the heater.

To reset the heater, turn the heater switch OFF. Turning the heater switch back ON will restart the ignition sequence.

TROUBLE SHOOTING TIPS

If the heater fails to start on a new installation make sure that 1) you have the proper power to the heater and 2) all air has been cleared from the gas line.

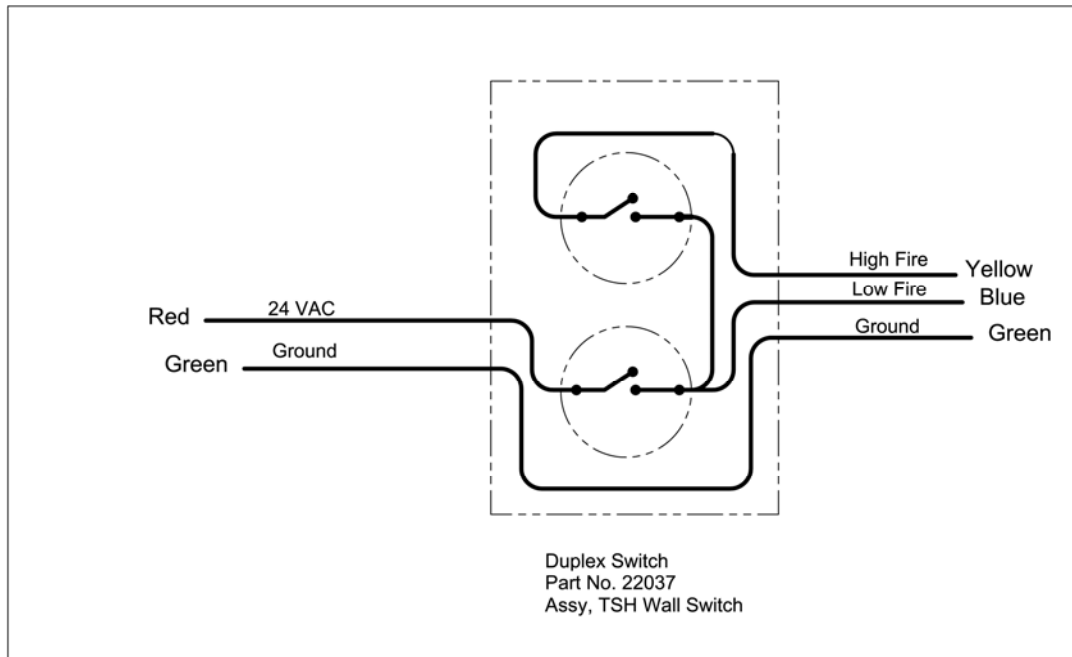

S34-TSH Wiring

It is important that the S34-TSH heater be wired properly to get full function of the heater and to avoid damage to the unit.

HI / LO Control Wiring

There are three wires that control the heater. The green wire is the ground wire. If one transformer is used for multiple heaters it is important that the ground wire for each heater is connected to the same side of the transformer. Cross wiring multiple heaters will short out the transformer and causing the transformer to fail.

The Blue Wire activates the ignition control and first stage (Low fire). The Yellow wire activates the second stage (Hi Fire). All electrical input into the heater must be 24 VAC. NOTE: For the heater to operate on the HI Fire mode 24 VAC must be applied to both blue and yellow wires.

NOTE ABOUT TRANSFORMERS

One 24 VAC transformer can be used for multiple heaters provided the transformer is properly sized for the number of heaters. Each heater requires approximately .7 amps or requires 20 VA from the transformer. For example, if two heaters are to be operated on one transformer, the transformer will need a minimum rating of 40 VA.

When installed outdoors, transformers may be required to be in a vented weather proof box. The transformer should never be installed in the control compartment of the heater as this will cause the transformer to overheat and the transformer to fail.

ADDITIONAL CONTROLS

Additional controls such as a timer or motion detector maybe incorporated with your

heaters controls. Thermostats are not recommended as radiant heaters warm up objects and people directly without first heating the air.

QUESTIONS

If you have questions regarding the proper installation or operation of the Sunpak Heater, contact your local distributor or call us at 1-888-317-5255.

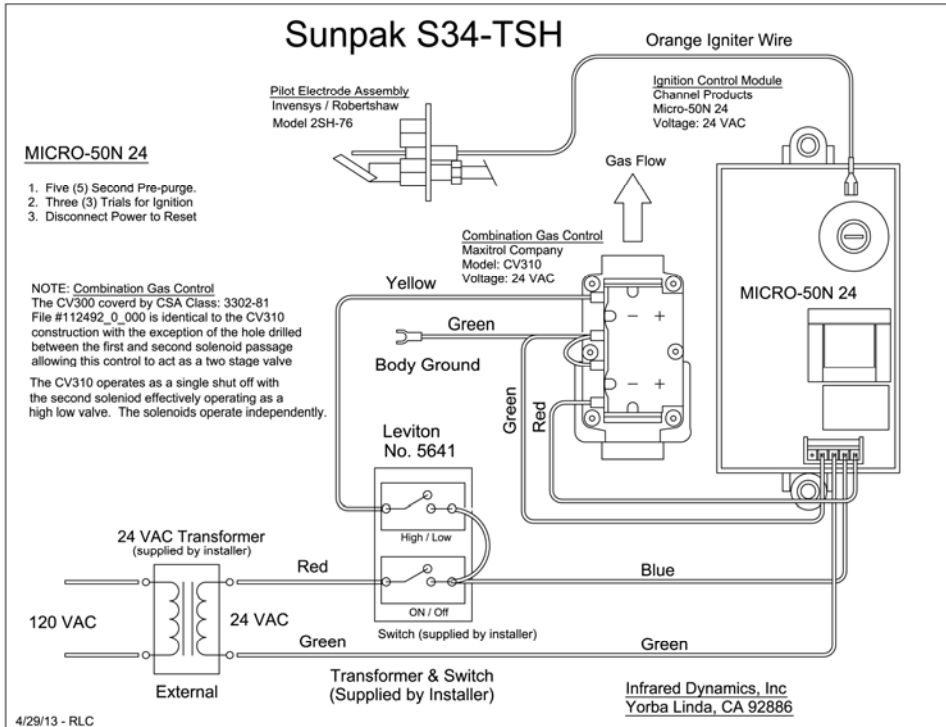

**Sunpak S34-TSH
Control Components**

No.	Part No.	Description
1	90073	Ctrl, CV310 -TSH
2	12015	Kit, Micro Module -TSH
3	90080-2	Harness, Micro - TSH
4	80063	Elbow, Orifice Adapter
5	35001-39	Orifice, #39 dms NG
	35001-50	Orifice, #50 dms LPcp
6	80032	Locknut, 3/8
7	90010	Kit, Pilot Tubing
8	92011	Connector, 3/8 Gas
9	22024	Assy, Pilot-Elect. 2SH76
10	90021	Natural Pilot Orifice
	90022	Propane Pilot Orifice
11	22037	Assy, TSH Wall Switch