

Features and Benefits

1. The complete tapping sleeve is constructed of 304 or 316 Stainless Steel (unless optional carbon steel flange fitting is ordered) and shall be passivated so as to return the welded stainless steel to its original corrosion resistant state.
2. Built in range allows reduction of inventory.
3. Drop in track head bolts with stainless steel nuts allow assembly in either direction. Available in NEVERGALL
4. 360° complete full circle mat o-ring gasket provides protection against leaks beyond o-ring seal.
5. The branch shall be a minimum of 3/8" larger diameter than nominal to allow the use of a full size cutter.
6. Stainless Steel and Carbon Steel outlets available.
7. Can be custom built for any pipe OD within limits.

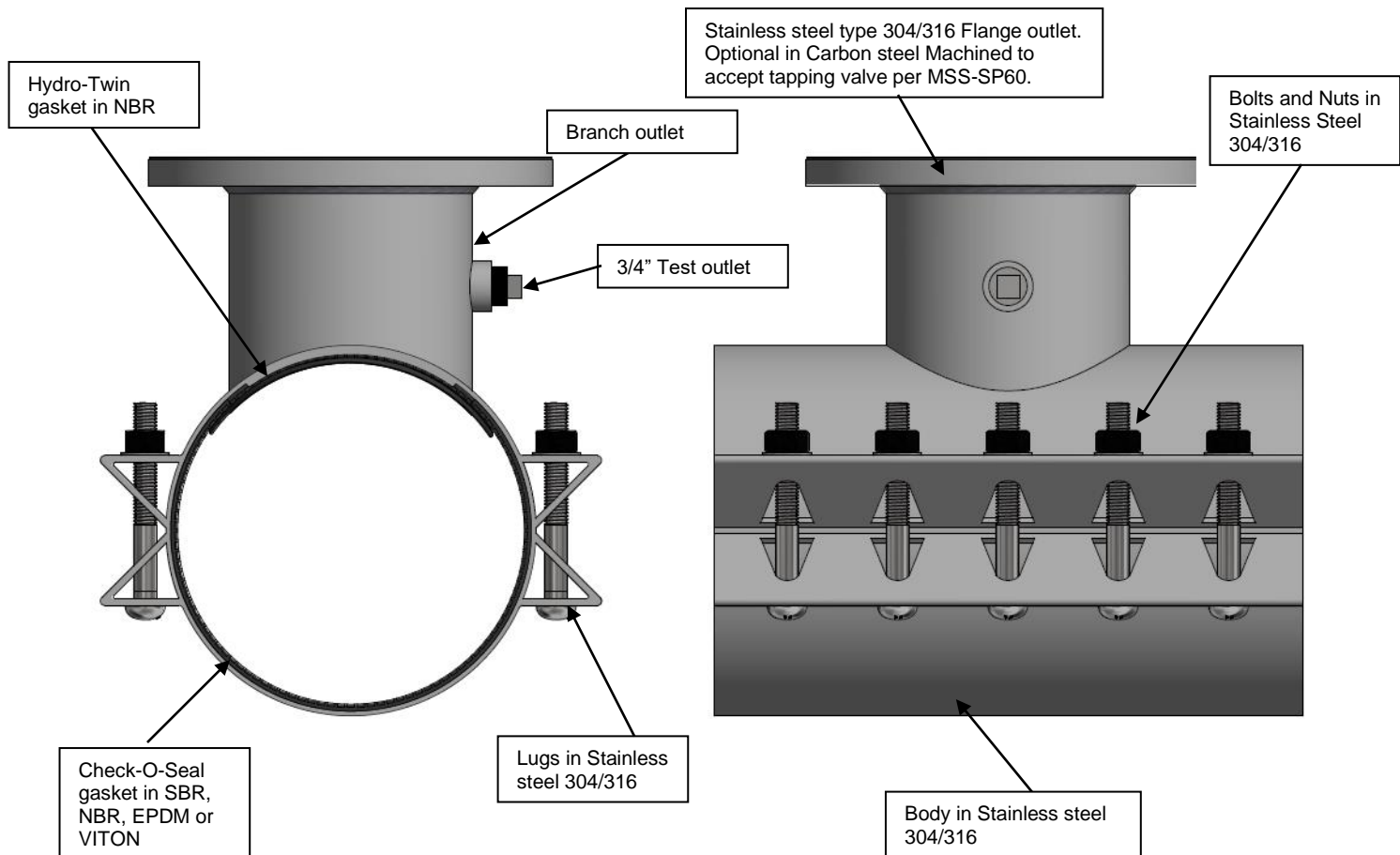

Scope

The intent of this specification is to receive a Stainless Steel Tapping Sleeve with a complete circle gasket and an incorporate a drop in bolt design ranging in pipe sizes from 4” and larger and with outlet sizes from 2” to 24”. The tapping sleeve furnished shall be equivalent to Model 3490AS Tapping Sleeve as manufactured by PowerSeal Pipeline Products Corporation

Design and Material Specification

The Tapping Sleeve shall be rated for a maximum working pressure of 250 psi and 312 psi testing pressure for outlet sizes 4” to 8”. For outlet sizes 10” and 12” a maximum working pressure 200 psi and 300 psi testing pressure. For pipe sizes 30” and larger a maximum working pressure up to 100 psi and 150 psi testing pressure.

1. Sleeve Body shall be fabricated completely from stainless steel grade 304 or 316 per ASTM A240. All welding shall be passivated so as to return the welded stainless steel to its original corrosion resistant state.
2. The Tapping Sleeve shall have a branch sealing gasket with the Hydro TwinSeal® dual o-ring design incorporating both hydrostatic and mechanical forces to affect a dynamic seal. A gridded complete circle gasket attached to the sleeve at the factory manufactured from SBR rated at (-40°F - +200°F). An industry standard mechanical joint outlet gasket complying with ANSI/AWWA C111/A21.11 must be supplied.
3. Branch to flange and branch to shell connections are double welded. Outer structural weld GMAW (FCAW) and inner fusion weld GTAW (TIG).
4. Lugs shall be fabricated of 304/316 stainless steel per ASTM A240, and are to be attached by means of a continuous weld (GMAW) to the body of the sleeve on at least one side, and shall be so designed to prevent the rotation of the head of the drop in bolts, and facilitate the installation of the sleeve.
5. The Tapping Sleeve shall incorporate drop-in, oval neck, track-head bolts type 304/316 (18-8) stainless steel per ASTM A193. Stainless steel 304 heavy hex nuts per ASTM A194.
6. Each tapping sleeve shall be factory hydrostatically tested at on pipe to verify proper fit and weld integrity with zero leakage allowed and will be designed to withstand the require working pressure.

3490AS / 3490AS-CS
 Tapping Sleeve with Flange outlet
 304/316 Stainless or Carbon Steel
 Certified to NSF/ANSI-61



7. There shall be no paper or plastic adhesive labels attached to the tapping sleeve, any information appearing on the sleeve shall be etched.
8. Consult factory about concerns at proper fit and ranges.
9. The minimum quantity of drop-in bolts per outlet diameter shall be:

Outlet Diameter	Drop-In Bolt Quantity	Flange Outlet bolt Quantity	Tapping Sleeve Width
2"	8pcs	2pcs	12"
3"	8pcs	4pcs	12"
4"	10pcs	8pcs	16"
6"	10pcs	8pcs	16"
8"	12pcs	8pcs	20"
10"	16pcs	12pcs	24"
12"	20pcs	12pcs	30"
16"	24pcs	16pcs	36"

Material Specifications		
Part Name	Material	Mat. specs
Flange Outlet	Stainless Steel 304/316 or Carbon Steel	AWWA C115
Flange Gasket	SBR	AWWA C115AP
Branch	Stainless Steel type 304/316	ASTM A240
Test Plug	Stainless Steel type 304/316	ANSI B2.1
Shell	Stainless Steel type 304/316	ASTM A240
Lugs	Stainless Steel type 304/316	ASTM A240
Hydro-twin	NBR	ASTM D2000
Gasket	SBR	ASTM D2000
Bolt	Stainless Steel type 304/316	ASTM A193
Nuts	Stainless Steel type 304/316	ASTM A194

