

FIGURE 7011Z HANGERS



HEAVY-DUTY ADJUSTABLE SWIVEL RING HANGER

FEATURES

- Size range: 2" through 8"
- Material: Carbon steel
- Finish: Zinc plated

PRODUCT SPECIFICATIONS

Services

- Recommend for suspension of non-insulated stationary pipe line
- Manufactured to use the min. rod size permitted by NFPA for fire sprinkler pipe line

Approvals

- Federal specifications: A-A-1192A (Type 10), WW-H-171-E (Type 10) and MSS-SP-69 (Type 10)
- FM approved and UL/ULC listed

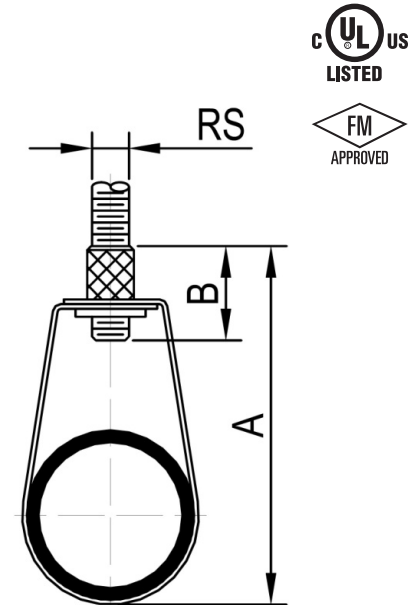

REFERENCE CHART

Catalog Number	Pipe Size		Rs		A		B		Wt.		Max. Rec. Load	
	in.	mm	in.	mm	in.	mm	in.	mm	lb	kg	lbs	N
FNW7011Z0200	2"	DN50	1/2	M12	4.53	115	1.26	32	0.19	0.09	1250	5560
FNW7011Z0250	2-1/2"	DN65	1/2	M12	5.51	140	1.26	32	0.33	0.15	1250	5560
FNW7011Z0300	3"	DN80	1/2	M12	6.42	163	1.26	32	0.4	0.18	1250	5560
FNW7011Z0350	3-1/2"	DN90	1/2	M12	6.85	174	1.26	32	0.42	0.19	1250	5560
FNW7011Z0400	4"	DN100	5/8	M16	7.60	193	1.42	36	0.49	0.22	1250	5560
FNW7011Z0600	6"	DN150	3/4	M20	10.43	265	1.77	45	0.88	0.4	1250	5560