



THIS IN-WALL DEHUMIDIFIER FEATURES A SLIM PROFILE TO MOUNT BETWEEN INTERIOR STUDS. THE **ULTRA AIRE MD33** IS DESIGNED TO CONTROL MOISTURE INCLUDING IN MULTI-FAMILY APPLICATIONS.

## MODEL 4035900

### PERFORMANCE

Water Removal	33 Pints / 4.125 Gallons
Efficiency	4.25 Pints/kWh
Energy Factor	2.0 L/kWh
Blower	155 CFM @ 0.0" WG
Operating Temperature	49°F Min., 95°F Max.
Sizing	Up to 1,200 Sq. Ft. / 12,000 Cu. Ft.

### ELECTRICAL

Power	324 watts @ 80°F and 60% RH
Supply Voltage	120 VAC – 1 phase – 60 Hz
Current Draw	2.8 amps
Power Cord	10', 115 VAC, Ground or Hard-Wired
Circuit Requirement	15 Amps



Plug Type B  
(USA, MEX, CAN, JPN)

### SPECIFICATIONS

Sound Rating	46 dBA
Drain Connection	3/4" O.D.
Drain Hose	10' Condensate Hose (3/4" ID)
Refrigerant	R134A, 10 oz.
Unit Dimensions	14.1875"W x 30"H x 5.75"D
Unit Weight	39 lbs.

### SHIPPING

Shipping Dimensions	20"W x 37"H x 11"D
Shipping Weight	57 lbs.
Pallet Quantity	8 per pallet
UPC Number	859029004717
Shipping Options	UPS or LTL

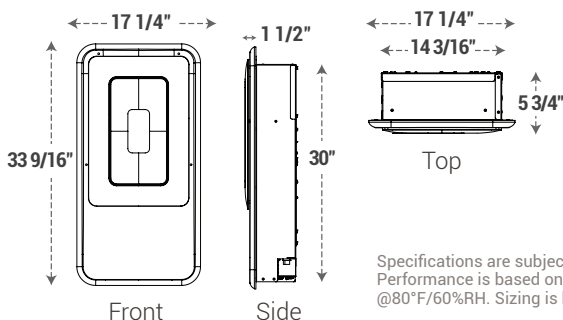

Specifications are subject to change without notice.  
Performance is based on pints / gallons per day  
@80°F/60%RH. Sizing is based on 10 foot ceiling height.

### FEATURES

- + Designed for quiet operation
- + Washable air filter
- + Ability to be hardwired into existing electrical or directly plugged into a 110v outlet
- + Designed to drain into a hub-drain or plumbing line
- + Internally mounted digital dehumidistat



**ULTRA-AIRE™**  
BY **SANTA-FE**



**FILTRATION**

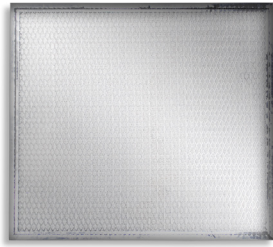

**WASHABLE FILTER**

- + For large particle filtration
- + Easy to clean every 1-2 months
- + Simple to remove and replace

**INSTALLATION**



**SURFACE MOUNT KIT**

- + Slim profile
- + Easy installation
- + Ideal for masonry or CMU block wall applications or when through-the-wall installation is not available
- + Powder-coated metal provides polished look to blend into any environment



**2X4 WALL MOUNT BEZEL KIT**

- + Slim profile
- + Easy installation
- + Ideal for applications with a 2x4 cavity without having to cut a hole in both sides of the drywall
- + Powder-coated metal provides polished look to blend into any environment



**REAR PANEL KIT**

- + Easy installation
- + Ideal for 2x4 cavity applications that require covering the back of the dehumidifier or to conceal gaps in drywall
- + Powder-coated metal attaches to rear of dehumidifier providing a polished look to blend into any environment

**PART NO. ITEM**

4037714	Washable Filter
4039155	Washable Filter, 6-Pack

**PART NO. ITEM**

4037766	Surface Mount Kit
---------	-------------------

**PART NO. ITEM**

4037767	2x4 Wall Mount Bezel Kit
---------	--------------------------

**PART NO. ITEM**

4037768	Rear Panel Kit
---------	----------------

**PARTS**

4036923	Power Board	4038144	Diffuser with Filter and Sound Dampening Insulation
4038072	Control Board	4038001	3/4" Crush Resistant Hose (10')
4037714	Filter	4037916	Tamper Resistant Screws
4037585	Blower	4035235-08	Compressor Capacitor
4036848	Temperature / RH Sensor	4035235-01	Blower Capacitor
4037996	Hose Clamp	4038145	Defrost Probe Kit

The Ultra Aire team is available Monday - Friday, 8 am - 5 pm CT.

**We want to hear from you, so don't hesitate to reach out.**

Need help with a warranty claim? Contact us at 800-533-7533.

Contact Customer Service at [orders@thermastor.com](mailto:orders@thermastor.com).

**SANTA-FE-PRODUCTS.COM**