



SERVICE PARTS LIST

BULLETIN NO.
54-06-2315

SPECIFY CATALOG NO. AND SERIAL NO. WHEN ORDERING PARTS			REVISED BULLETIN	DATE
USB RECHARGEABLE BEACON™ HARD HAT LIGHT				June 2019
CATALOG NO.	2116-21	STARTING SERIAL NO.	H90A	
WIRING INSTRUCTION				

EXAMPLE:
Component Parts (Small #)
Are Included When Ordering
The Assembly (Large #).

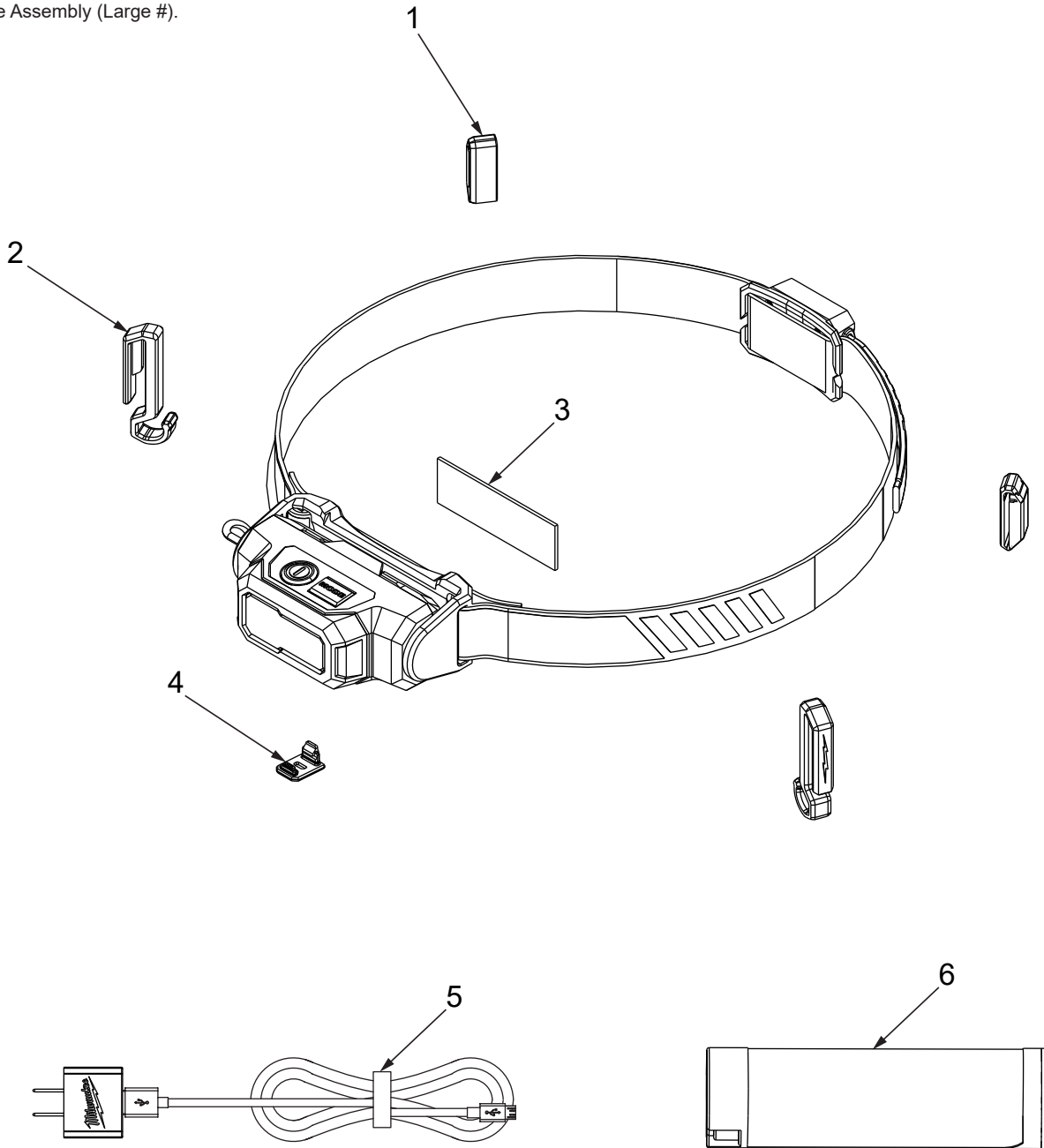

FIG.	PART NO.	DESCRIPTION OF PART	NO. REQ.
1	42-70-2116	Light Band Clip Kit (Set of 2)	(1)
2	42-70-2117	Hard Hat Clips (Set of 2)	(1)
3	44-52-0015	Pad	(1)
4	31-15-0605	Rubber USB Cover	(1)
5	48-59-1202	Wall Plug and Micro-USB Cable (Optional)	(1)
6	48-11-2130	REDLITHIUM® USB Battery (Optional)	(1)
7	12-20-2116	Service Nameplate (Not Shown)	(1)

FIG. NOTES

7 A clean, dry surface is essential for proper performance for any adhesive system. The area intended for application of any adhesive label or nameplate must be prepared by cleaning with isopropyl alcohol. The solvent is to be applied with a clean, lint free applicator and the surface allowed to dry before applying the label or nameplate.