



Product Data

INDUSTRY LEADING FEATURES / BENEFITS

A PERFECT BALANCE BETWEEN BUDGET LIMITS, ENERGY SAVINGS AND COMFORT.

The ductless systems are a matched combination of an outdoor condensing unit and an indoor fan coil unit connected only by refrigerant tubing and wires.

The ductless system permits creative solutions to design problems such as:

- Add- ons to current space (an office or family room addition)
- Special space requirements
- When changes in the load cannot be handled by the existing system
- When adding air conditioning to spaces that are heated by hydronic or electric heat and have no ductwork
- Historical renovations or any application where preserving the look of the original structure is essential.

The ideal compliment to your ducted system when it is impractical or prohibitively expensive to use ductwork.

The compact indoor fan coil units take up very little space in the room and do not obstruct windows. The fan coils are attractively styled to blend with most room decors. Advanced system components incorporate innovative technology to provide reliable cooling performance at low sound levels.



Fig. 1 —Sizes 09K-36K

NOTE: Images are for illustration purposes only. Actual models may differ slightly.

TABLE OF CONTENTS

INDUSTRY LEADING FEATURES / BENEFITS..... 1

MODEL NUMBER NOMENCLATURE 3

STANDARD FEATURES AND ACCESSORIES 4

DIMENSIONS 5

CLEARANCES..... 9

SPECIFICATIONS - OUTDOOR HEAT PUMP..... 10

PERFORMANCE 11

COOLING PERFORMANCE DATA - HIGH WALL 13

HEATING PERFORMANCE DATA - HIGH WALL 15

COOLING PERFORMANCE DATA - CASSETTE 17

HEATING PERFORMANCE DATA - CASSETTE 18

COOLING PERFORMANCE DATA - DUCTED..... 19

HEATING PERFORMANCE DATA - DUCTED..... 20

COOLING PERFORMANCE DATA - CONSOLE 21

HEATING PERFORMANCE DATA - CONSOLE..... 22

COOLING PERFORMANCE DATA - AIR HANDLER..... 23

HEATING PERFORMANCE DATA - AIR HANDLER..... 23

APPLICATION DATA 24

WIRING 25

AIR FLOW DATA 26

ELECTRICAL DATA 26

WIRING DIAGRAMS..... 27

GUIDE SPECIFICATIONS..... 30

Inverter Technology

The inverter driven compressor is designed to run at various input power frequencies (Hz) which controls the compressor's motor speed.

Even Temperature – The control package, including the inverter, monitors the outdoor and indoor temperatures as they relate to the selected indoor set point and adjusts the compressor speed to match the load and keep the system operating continuously rather than cycling and creating temperature swings. This translates to higher comfort levels for the occupants.

Rapid Pull Down/Warm-Up – Comfort is increased by the inverter system's ability to ramp up the compressor speed enabling the system to reach the user selected room temperature set point quicker.

Humidity Control – Running the system for longer periods and continuously varying the compressor speed enhances the humidity control.

Individual Room Comfort

Maximum comfort is provided because each space can be controlled individually based on the usage pattern.

Low Sound Levels

When noise is a concern, ductless systems are the answer. The indoor units are whisper quiet. There are no compressors indoors, either in the conditioned space or directly over it, and there is none of the noise usually generated by air being forced through the ductwork.

When sound ordinances and proximity to neighbors demand quiet operation, the ductless unit is the right choice. With the inverter technology, these units run at lower speeds most of the time resulting in reduced sound levels.

Inverter Technology – Enhanced Economical Operation

Ductless systems are inherently economical to operate. Individual rooms are heated or cooled only when required, and since the air is delivered directly to the space, there is no need to use additional energy to move the air in the ductwork. This economical operation is enhanced further when the inverter system output matches the load resulting in a more efficient system.

Easy-To- Use Controls

The systems have microprocessor-based controls to provide the ultimate in comfort and efficiency. The user friendly wired and wireless remote controls provide the interface between the user and the unit.

Secure Operation

If security is an issue, outdoor and indoor units are connected only by refrigerant piping and wiring to prevent intruders from crawling through ductwork or wall openings. In addition, since the ductless outdoor can be installed close to an outside wall, coils are protected from vandals and severe weather.

Fast Installation

This compact ductless system is simple to install. Only wires and piping need to run between the indoor and outdoor units. These units are fast and easy to install ensuring minimal disruption to customers in homes or the workplace. This makes the ductless systems the equipment of choice for retrofit applications.

Simple Servicing and Maintenance

Removing the top panel of the outdoor unit provides immediate access to the control compartment, providing the service technician access to the diagnostic LEDs to facilitate the troubleshooting process. In addition, the draw- thru design of the outdoor unit means that dirt accumulates on the outside surface of the coil. Coils can be cleaned quickly from the inside using a pressure hose and detergent.

On the indoor units, service and maintenance expense is reduced due to the permanent easy to clean filters. Also, error codes are displayed on the front panel to alert the user to certain system malfunctions

Built- in Reliability

Ductless system indoor and outdoor units are designed to provide years of trouble- free operation. Both the indoor and outdoor units are well protected. Whenever the microprocessor detects abnormal conditions, the unit stops and an error code appears. Inverter systems provide additional reliability due to the soft start.

This refers to the ability of the inverter to start the compressor motor using reduced voltage and reduced current. This feature is beneficial from an electrical standpoint (eliminates current spikes) as well as an overall reliability standpoint due to reduced stress on all associated system components.

Agency Listings

All systems are listed with AHRI (Air conditioning, Heating, and Refrigeration Institute) and are ETL certified per UL 1995 standard.

MODEL NUMBER NOMENCLATURE

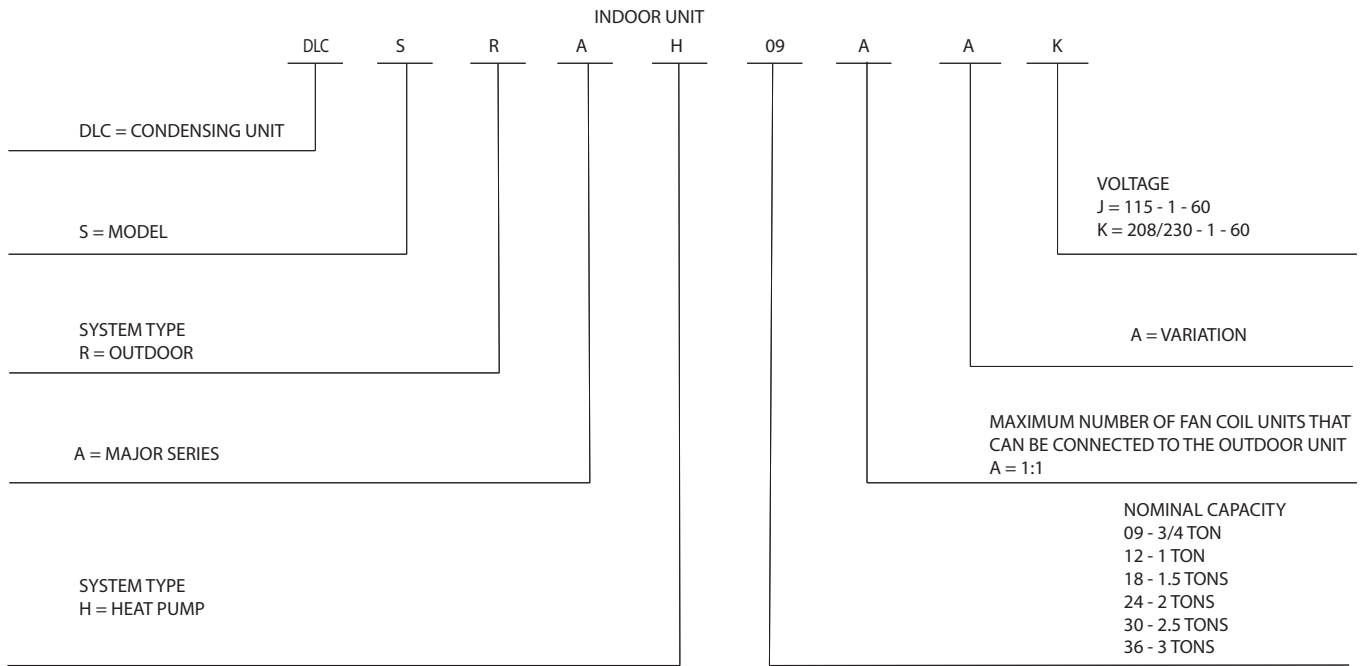

Use of the AHRI Certified TM Mark indicates a manufacturer's participation in the program. For verification of certification for individual products, go to www.ahridirectory.org.



STANDARD FEATURES AND ACCESSORIES

Ease Of Installation	
Low Voltage Controls	S
Comfort Features	
Microprocessor Controls	S
Auto Restart Function	S
Low Ambient Cooling	S
Low Ambient Heating	S
Auto Changeover	S
Energy Saving Features	
Inverter Driven Compressor	S
46° F Heating Mode (Heating Setback)	S
Safety And Reliability	
3 Minute Time Delay For Compressor	S
High Compressor Discharge Temperature	S
Low Voltage Protection	S
Compressor Overload Protection	S
Compressor Over Current Protection	S
IPM Module Protection	S
Condenser High Temperature Protection in Cooling Mode	S
Aluminum Hydrophilic pre-coated fins	S
Ease Of Service And Maintenance	
Diagnostics	S
Liquid Line Pressure Taps	S
Application Flexibility	
Crankcase Heater	S
Base Pan Heater	S

Outdoor Units

Crankcase Heater

The crankcase heater is standard on all unit sizes. Heater clamps must be placed around the compressor oil stump.

Base pan Heater

The base pan heater is standard on all unit sizes.

Legend

S - Standard

A - Accessory

Accessories

Outdoor Unit Model Number	Base Pan Base Rubber Plugs RCD Part Number	Quantity per Unit
DLCSRAH12AAJ DLCSRAH09AAK DLCSRAH12AAK	12600801A00077	13
DLCSRAH18AAK	12600801A00077	25
DLCSRAH24AAK DLCSRAH30AAK DLCSRAH36AAK	12600801A00117	5

NOTE: Basepan built in with multiple holes for proper draining during defrost. For applications where is required to seal these holes, and re- direct the condensate drain, rubber plugs are available through RCD.

DIMENSIONS

UNIT SIZE		12K	9K	12K	18K	24K	30K	36K
VOLTAGE		115V	208/230V	208/230V	208/230V	208/230V	208/230V	208/230V
Height (H)	in (mm)	21.81(554)	21.81(554)	21.81(554)	27.63(702)	31.89(810)	31.89(810)	31.89(810)
Width (W)	in (mm)	32.09(815)	32.09(815)	32.09(815)	33.66 (855)	37.24(946)	37.24(946)	37.24(946)
Depth (D)	in (mm)	13.11(333)	13.11(333)	13.11(333)	14.17(360)	16.14(410)	16.14(410)	16.14(410)
L1	in (mm)	20.24(514)	20.24 (514)	20.24(514)	21.26(540)	26.50(673)	26.50(673)	26.50(673)
L2	in (mm)	13.39(340)	13.39 (340)	13.39(340)	13.78(350)	15.87(403)	15.87(403)	15.87(403)
Operating Weight	Lbs (kg)	82.9(37.6)	91.5(41.5)	91.5(41.5)	118.2(53.6)	145.5(66)	139.8(63.4)	147.3(66.8)

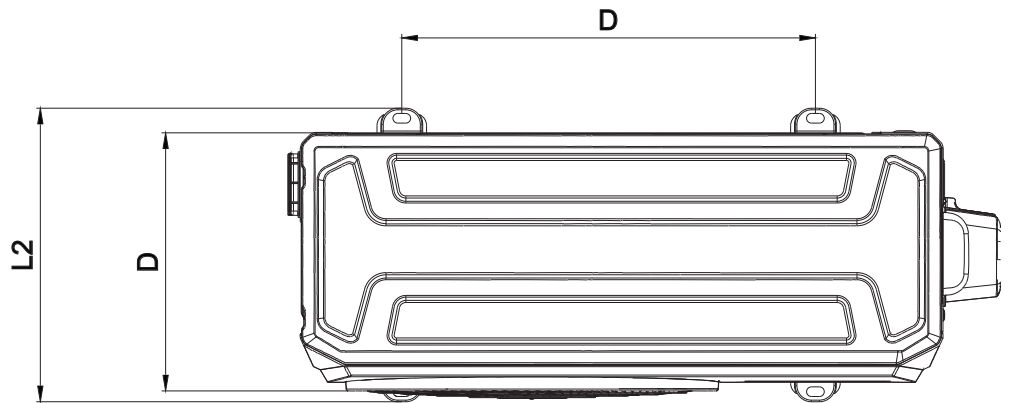
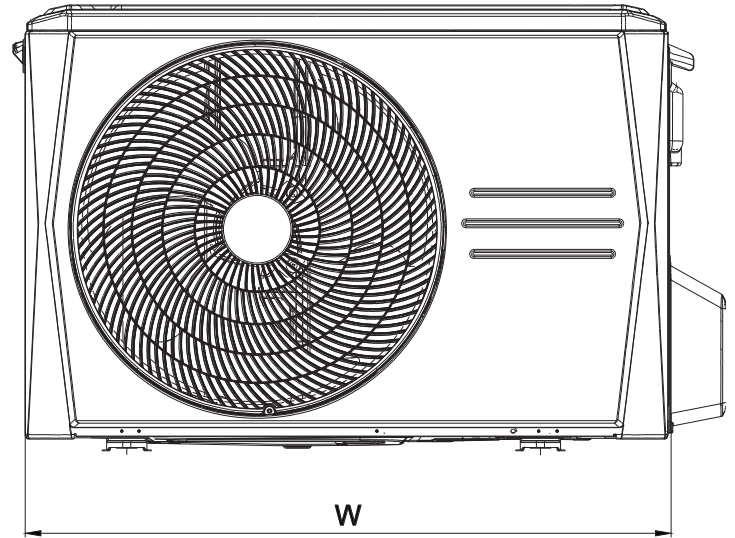
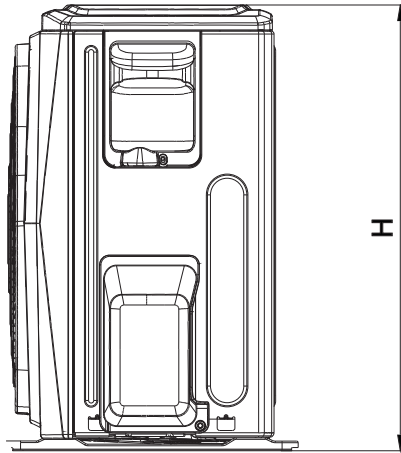

Fig. 2 — Outdoor Unit

DIMENSIONS (CONT)

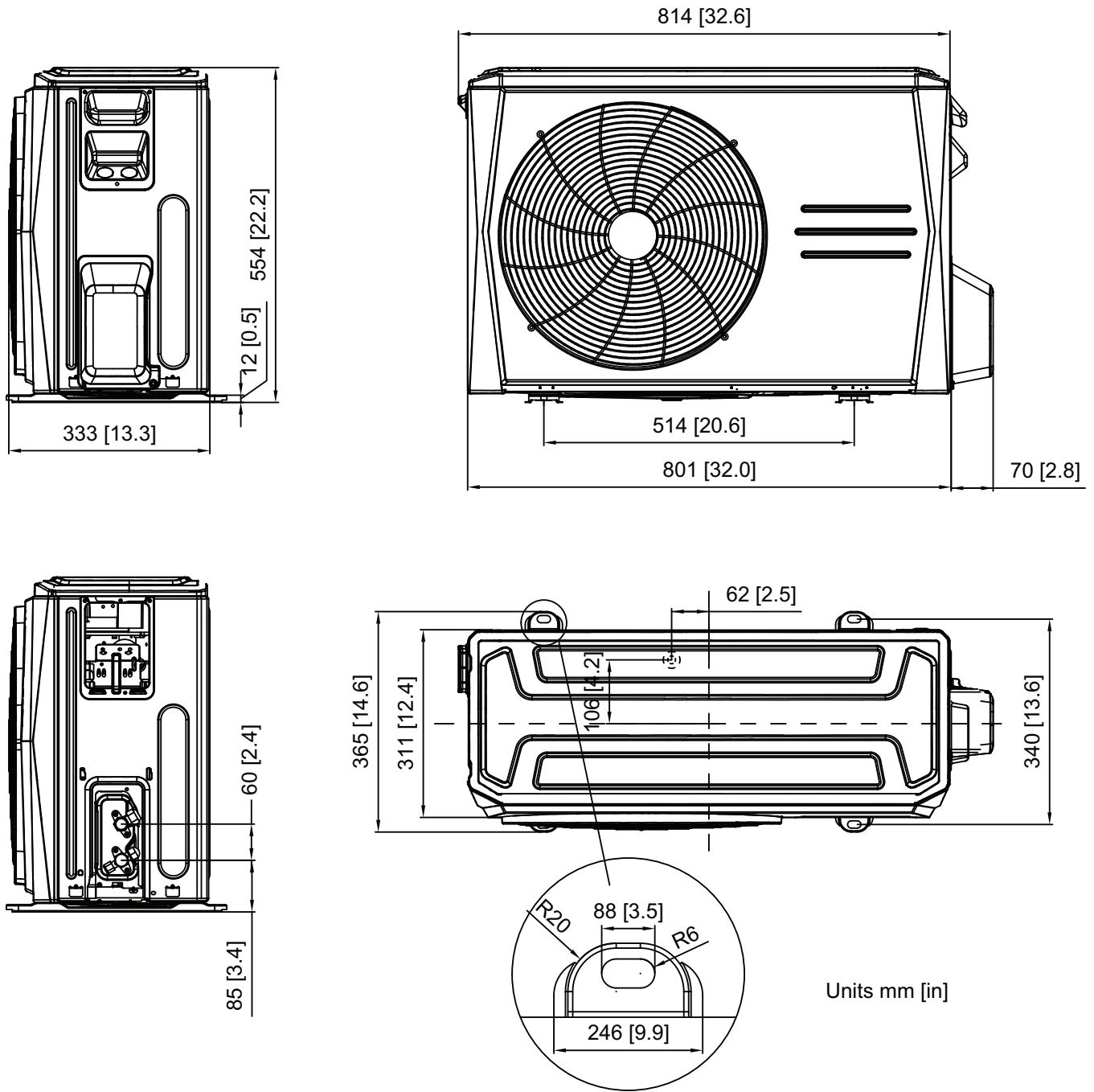

Fig. 3 — Sizes 12K (115V), 09K and 12K (208/230V)

DIMENSIONS (CONT)

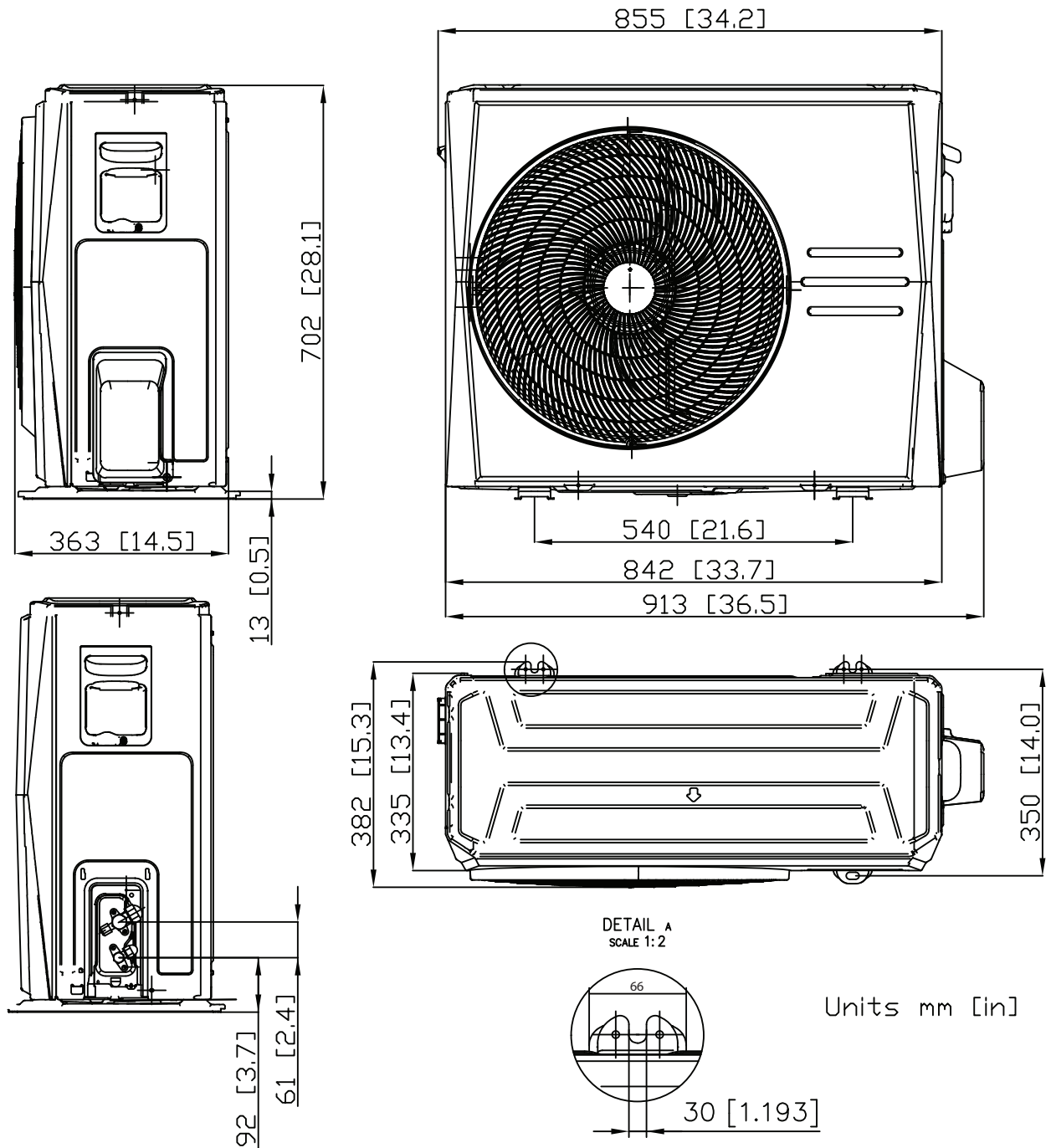

Fig. 4 — Size 18K

DIMENSIONS (CONT)

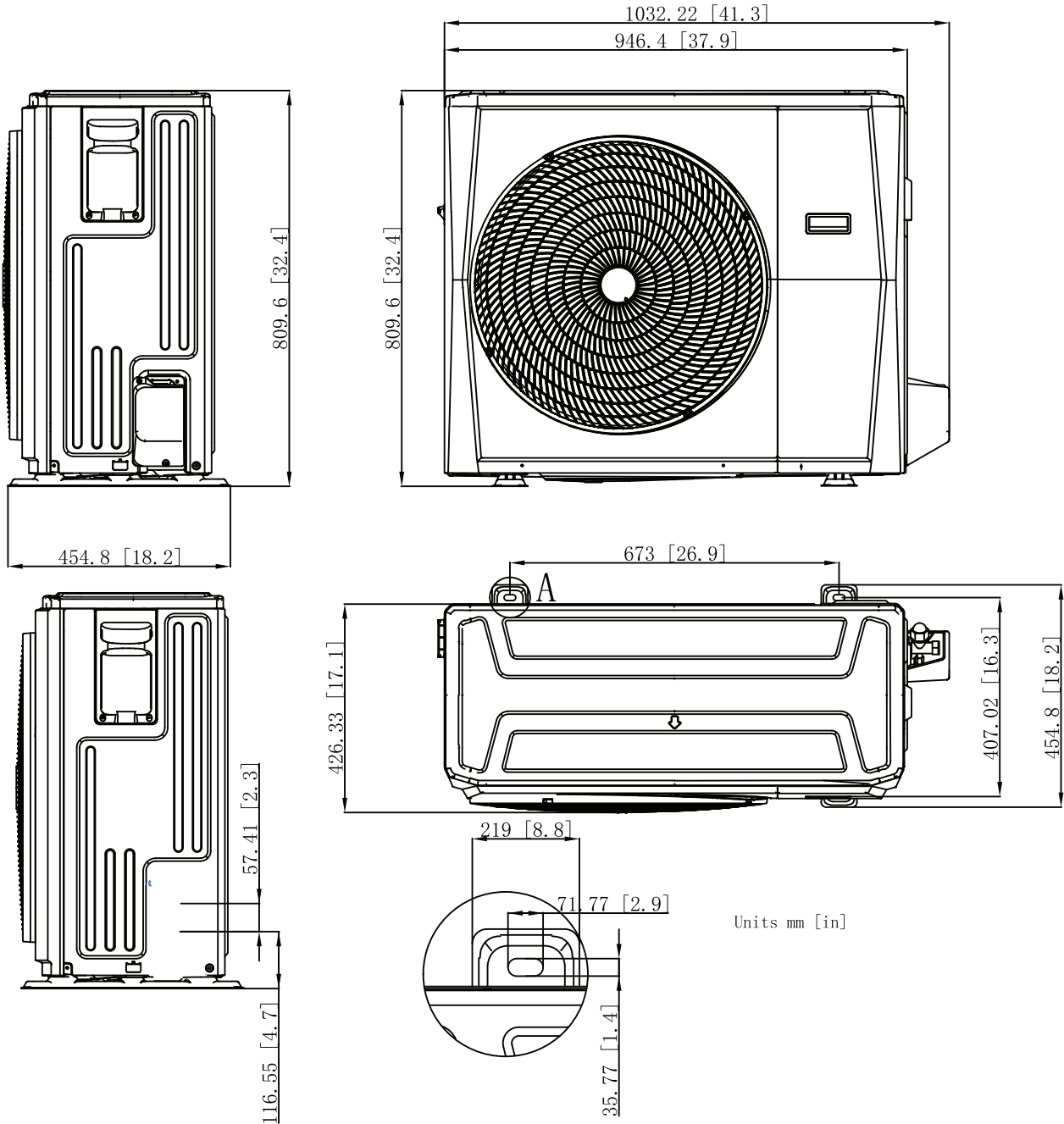

Fig. 5 — Sizes 24K - 36K

CLEARANCES

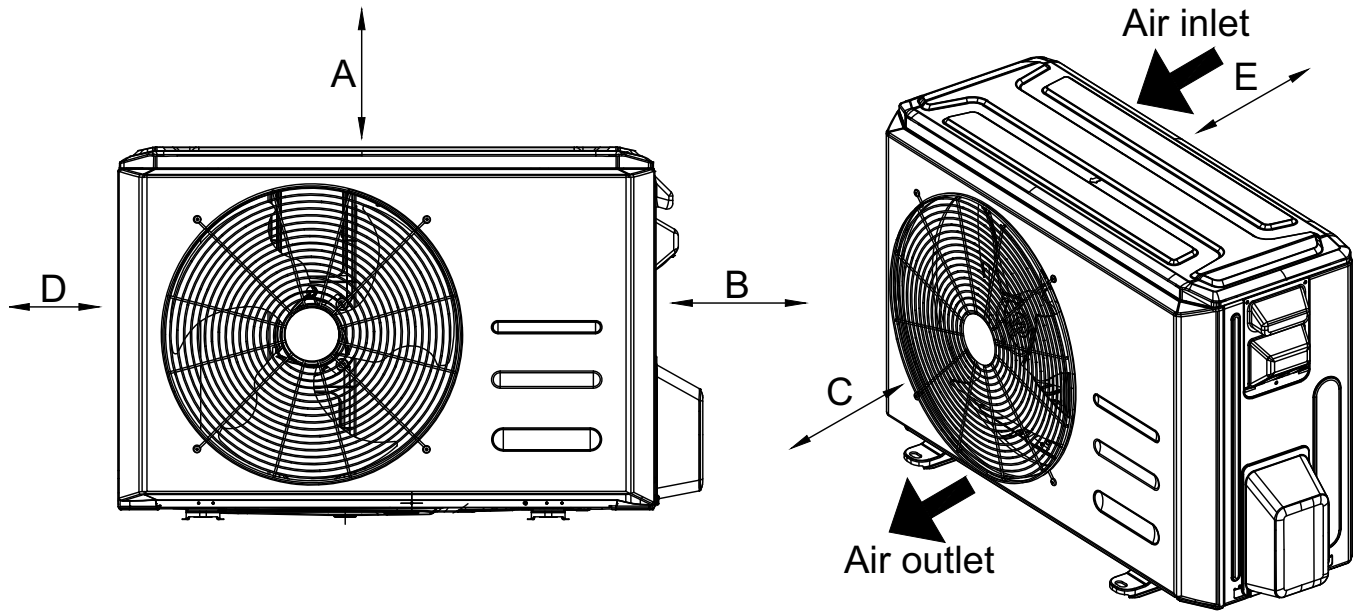

Fig. 6 — Clearances

UNIT	MINIMUM VALUE IN. (MM)
A	24 (609)
B	24 (609)
C	24 (609)
D	4 (101)
E	4 (101)

NOTE: The outdoor unit must be mounted at least 2in (50mm) above the maximum anticipated snow depth.

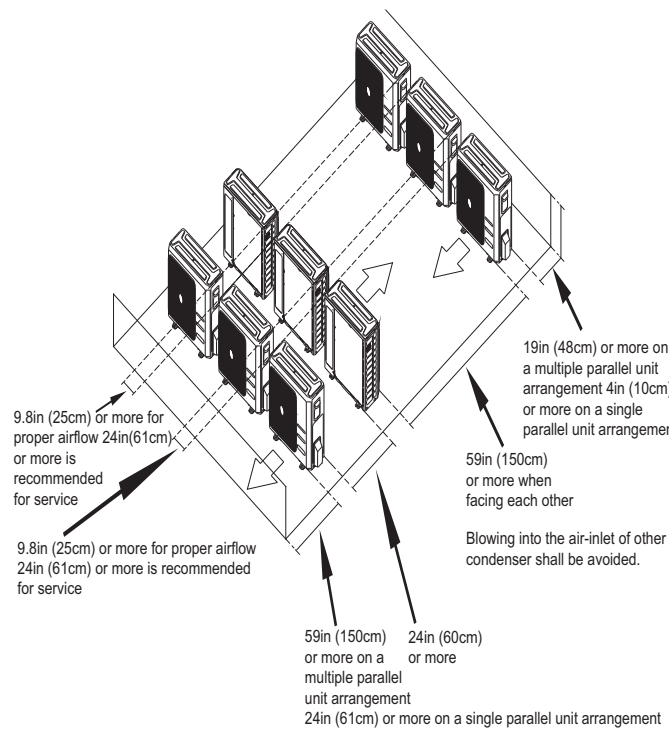

Fig. 7 — Clearances for multiple units

SPECIFICATIONS - OUTDOOR HEAT PUMP

HEAT PUMP									
System	SIZE		12	09	12	18	24	30	36
	Outdoor Model		DLCRAH12AAJ	DLCRAH09AAK	DLCRAH12AAK	DLCRAH18AAK	DLCRAH24AAK	DLCRAH30AAK	DLCRAH36AAK
Electrical	Voltage, Phase, Cycle	V/Ph/Hz	115-1-60	208/230-1-60	208/230-1-60	208/230-1-60	208/230-1-60	208/230-1-60	208/230-1-60
	MCA	A.	15	9	9	17	20	20	25
	MOCP - Fuse Rating	A.	20	15	15	25	30	30	35
Operating Range	Cooling Outdoor DB Min - Max	°F (°C)	-13~122 (-25~50)	-13~122 (-25~50)	-13~122 (-25~50)	-13~122 (-25~50)	-13~122 (-25~50)	-13~122 (-25~50)	-13~122 (-25~50)
	Heating Outdoor DB Min - Max	°F (°C)	-13~86 (-25~30)	-22~86 (-30~30)	-22~86 (-30~30)	-22~86 (-30~30)	-22~86 (-30~30)	-13~86 (-25~30)	-13~86 (-25~30)
Piping	Total Piping Length	ft (m)	82 (25)	82 (25)	82 (25)	98 (30)	98 (30)	164 (50)	164 (50)
	Piping Lift*	ft (m)	32 (10)	32 (10)	32 (10)	66 (20)	66 (20)	82 (25)	82 (25)
	Pipe Connection Size - Liquid	in (mm)	1/4 (6.35)	1/4 (6.35)	1/4 (6.35)	1/4 (6.35)	3/8 (9.52)	3/8 (9.52)	3/8 (9.52)
	Pipe Connection Size - Suction	in (mm)	1/2 (12.7)	3/8 (9.52)	1/2 (12.7)	1/2 (12.7)	5/8 (16)	5/8 (16)	5/8 (16)
Refrigerant	Type		R410A	R410A	R410A	R410A	R410A	R410A	R410A
	Charge	lbs (kg)	2.64 (1.15)	3.31 (1.5)	3.31 (1.5)	4.3 (1.95)	5.73 (2.6)	6.06 (2.75)	7.49 (3.4)
	Metering Device		EEV	EEV	EEV	EEV	EEV	EEV	EEV
Outdoor Coil	Face Area	Sq. Ft.	4.7	4.7	4.7	5.2	8.2	8.2	8.1
	No. Rows		2	2	2	2	2	2.6	3
	Fins per inch		20	18	18	18	20	18	18
	Circuits		4	4	4	4	4	6	6
Compressor	Type		Rotary Inverter	Rotary Inverter	Rotary Inverter	Rotary Inverter	Rotary Inverter	Rotary Inverter	Rotary Inverter
	Model		ASN98D22UFZ	ATM115D43UFZ2	ATM115D43UFZ2	ATF235D22UMT	ATF235D22UMT	ATF250D22UMT	ATF250D22UMT
	Oil Type		VG74	VG74	VG74	VG74	VG74	VG74	VG74
	Oil Charge	Fl. Oz.	13.0	17.6	17.6	23.6	23.6	23.6	23.6
	Rated Current	RLA	10.5	5.3	5.7	12.3	14.0	15.0	17.0
Outdoor	Unit Width	in (mm)	31.5 (800)	31.5 (800)	31.5 (800)	33.27 (845)	37.24 (946)	37.24 (946)	37.24 (946)
	Unit Height	in (mm)	21.81 (554)	21.81 (554)	21.81 (554)	27.63 (702)	31.89 (810)	31.89 (810)	31.89 (810)
	Unit Depth	in (mm)	13.11 (333)	13.11 (333)	13.11 (333)	14.26 (363)	16.54 (420)	16.54 (420)	16.54 (420)
	Net Weight	lbs (kg)	80.7 (36.6)	90.8 (41.2)	91.7 (41.6)	113.3 (51.4)	141.1 (64)	137.8 (62.5)	143.3 (65)
	Airflow	CFM	1,177	1,177	1,177	1,824	2,355	2,119	2,119
	Sound Pressure	dB(A)	54.7	56.6	54.6	58.9	61.0	60.0	60.0

* Condensing unit above or below the indoor unit

COMPATIBILITY

OUTDOOR UNITS							
INDOOR UNITS	DLCSRAH12AAJ	DLCSRAH09AAK	DLCSRAH12AAK	DLCSRAH18AAK	DLCSRAH24AAK	DLCSRAH30AAK	DLCSRAH38AAK
High Wall	DLFSHAH12XAJ	•					
	DLFSHAH09XAK		•				
	DLFSHAH12XAK			•			
	DLFSHAH18XAK				•		
	DLFSHAH24XAK					•	
	DLFSHAH30XAK						•
Cassette	DLFSCAH09XAK	•					
	DLFSCAH12XAK			•			
	DLFSCAH18XAK				•		
	DLFSCAH24XAK					•	
	DLFLCAH36XAK						•
	DLFLCAH48XAK						
Ducted	DLFSDAH09XAK	•					
	DLFSDAH12XAK			•			
	DLFSDAH18XAK				•		
	DLFSDAH24XAK					•	
	DLFLDAH36XAK						•
	DLFLDAH48XAK						
Console	DLFSFAH12XAK			•			
	DLFSFAH18XAK				•		
	DLFSFAH24XAK					•	
	DLFLFAH36XAK						•
	DLFLFAH48XAK						
Air Handler	DLFSAAH24XAK					•	

NOTE: *Cassette, Ducted and Console indoor units sizes 36, 48 & 58 ONLY compatible with DLCLRA Outdoor Unit

PERFORMANCE

High Wall

INDOOR MODEL	DLFSHAH12XAJ	DLFSHAH09XAK	DLFSHAH12XAK	DLFSHAH18XAK	DLFSHAH24XAK	DLFSHAH30XAK	DLFSHAH36XAK
Energy Star	YES	YES	YES	YES	YES	YES	NO
Cooling System Tons	1.0	0.75	1.0	1.5	2.0	2.5	3.0
Cooling Rated Capacity	12,000	9,000	12,000	18,000	24,000	30,000	36,000
Cooling Cap. Range Min - Max	3,500-12,200	3,500-12,600	4,200-12,900	4,300-21,200	5,200-23,000	8,000-32,500	8,000-37,800
SEER	20.4	24.7	21.5	22.0	20.0	20.0	18.0
EER	12.5	14	12.5	12.5	12.5	12.5	10.5
Heating Rated Capacity (47°F)	11,800	12,000	12,000	18,000	25,000	30,000	36,000
Heating Rated Capacity (17°F)	7,200	7,500	7,600	11,900	15,000	18,000	21,000
Heating Maximum Capacity (17°F)	8,000	12,400	12,800	21,500	22,700	25,300	29,700
Heating Maximum Capacity (5°F)	7,800	10,700	12,100	20,700	23,300	19,500	23,400
Heating Cap. Range Min-Max	1,300-124,00	1,300-14,500	1,400-13,900	2,900-22,900	2,300-26,800	2,600-30,400	2,700-36,000
HSPF	11.0	10.5	11.0	10.5	10.0	9.8	10.0
COP (47°F)	3.20	3.17	3.20	3.22	2.93	3.52	3.44
COP (17°F)	2.60	2.65	2.40	2.50	2.35	2.55	2.60
COP (5°F)	2.01	2.10	1.78	1.89	1.82	1.64	2.56

Cassette

INDOOR MODEL	DLFSCAH09XAK	DLFSCAH12XAK	DLFSCAH18XAK	DLFSCAH24XAK
Energy Star	YES	YES	YES	YES
Cooling System Tons	0.8	1.0	1.4	2.0
Cooling Rated Capacity	9,000	12,000	16,000	24,000
Cooling Cap. Range Min - Max	3,000- 13,000	3,300- 12,000	6,000- 18,700	11,000- 28,600
SEER	20.0	19.5	20.0	20.0
EER	13.0	12.5	12.5	11.0
Heating Rated Capacity (47° F)	10,000	12,000	18,000	24,000
Heating Rated Capacity (17° F)	6,700	8,200	12,000	16,200
Heating Maximum Capacity (17° F)	14,300	14,700	22,700	31,700
Heating Maximum Capacity (5° F)	12,200	12,300	20,000	30,000
Heating Cap. Range Min - Max	4,000- 15,200	3,300- 15,000	8,900- 21,400	10,200- 33,600
HSPF	10.2	10.2	10.5	11.5
COP (47° F)	3.37	3.55	2.95	3.66
COP (17° F)	2.57	2.43	2.58	2.97
COP (5° F)	1.94	1.94	2.40	1.87

PERFORMANCE (CONT)

Ducted

Indoor Model	DLFSDAH09XAK	DLFSDAH12XAK	DLFSDAH18XAK	DLFSDAH24XAK
Energy Star	YES	YES	YES	YES
Cooling System Tons	0.75	1.0	1.4	2.0
Cooling Rated Capacity	9,000	12,000	16,500	24,000
Cooling Cap. Range Min - Max	3,000- 13,000	3,300- 12,000	6,000- 18,700	11,000- 28,600
SEER	22.5	20.5	20.0	21.0
EER	14.0	12.5	12.5	12.5
Heating Rated Capacity (47° F)	10,000	12,500	19,000	24,000
Heating Rated Capacity (17° F)	6,800	8,100	12,400	17,400
Heating Maximum Capacity (17° F)	14,300	14,700	22,700	31,700
Heating Maximum Capacity (5° F)	12,200	12,300	20,000	30,000
Heating Cap. Range Min - Max	4,000- 15,200	3,300- 15,000	8,900- 21,400	10,200- 33,600
HSPF	11.5	11.0	10.8	12.0
COP (47° F)	3.37	3.55	2.95	3.66
COP (17° F)	2.57	2.43	2.58	2.97
COP (5° F)	1.77	1.81	1.45	1.93

Console

Indoor Model	DLFSFAH12XAK	DLFSFAH18XAK	DLFSFAH24XAK
Energy Star	YES	YES	NO
Cooling System Tons	1.0	1.4	2.0
Cooling Rated Capacity	12,000	17,000	24,000
Cooling Cap. Range Min - Max	4,200- 13,100	6,600- 20,600	11,000- 29,200
SEER	19.4	19.9	20.0
EER	12.5	12.5	11.5
Heating Rated Capacity (47° F)	12,000	18,000	24,000
Heating Rated Capacity (17° F)	9,600	12,900	17,200
Heating Maximum Capacity (17° F)	13,500	21,500	27,950
Heating Maximum Capacity (5° F)	12,300	18,700	25,000
Heating Cap. Range Min - Max	4,800- 13,600	9,000- 22,300	10,200- 18,400
HSPF	10.5	10.2	11.5
COP (47° F)	3.43	3.48	3.66
COP (17° F)	2.66	2.30	2.80
COP (5° F)	1.76	1.77	1.81

Air Handler

Indoor Model	DLFSAAH24XAK
Outdoor Model	DLCSRAH24AAK
Energy Star	YES
Cooling System Tons	1.7
Cooling Rated Capacity	20,800
Cooling Cap. Range Min - Max	6,000~23,000
SEER	20.0
EER	12.5
Heating Rated Capacity (47°F)	29,000
Heating Rated Capacity (17°F)	17,500
Heating Maximum Capacity (17°F)	29,700
Heating Maximum Capacity (5°F)	26,970
Heating Cap. Range Min - Max	6,000~30,000
HSPF	10.0
COP (47°F)	3.48
COP (17°F)	2.30
COP (5°F)	2.10

COOLING PERFORMANCE DATA - HIGH WALL

High Wall (Sheet 1 of 2)

MODEL	COOLING			OUTDOOR CONDITIONS (DB)											
	Indoor Conditions DB			-13°F (-25°C)	-4°F (-20°C)	0°F (-17°C)	5°F (-15°C)	17°F (-8°C)	47°F (8°C)	77°F (25°C)	86°F (30°C)	95°F (35°C)	104°F (40°C)	113°F (45°C)	122°F (50°C)
	DB	WB													
12 (115V)	69.8°F (21°C)	59°F (15°C)	TC	11.01	10.43	11.24	11.44	11.50	10.56	8.21	11.07	10.45	9.73	7.88	4.96
			SC	7.69	7.34	7.73	7.85	7.86	7.42	6.34	7.67	7.39	7.06	6.26	4.94
			Input	0.52	0.60	0.48	0.46	0.43	0.46	0.45	0.90	0.97	1.06	1.00	0.81
	75.2°F (24°C)	62.6°F (17°C)	TC	11.49	10.90	12.25	12.11	12.18	11.43	9.00	11.90	11.21	10.29	8.30	5.44
			SC	8.00	7.73	8.33	8.34	8.31	7.99	6.92	8.18	7.85	7.45	6.58	5.41
			Input	0.57	0.65	0.46	0.50	0.46	0.48	0.46	0.91	0.99	1.04	0.96	0.81
	80.6°F (27°C)	66.2°F (19°C)	TC	11.97	11.79	12.93	12.77	13.03	12.41	11.54	12.62	12.21	11.49	9.41	6.14
			SC	8.30	8.24	8.71	8.73	8.77	8.52	8.17	8.67	8.46	8.16	7.32	6.10
			Input	0.64	0.65	0.49	0.53	0.49	0.61	0.92	1.00	1.00	1.10	1.00	0.82
	89.6°F (32°C)	73.4°F (23°C)	TC	12.99	13.66	14.54	14.30	14.81	15.95	13.29	13.05	12.97	12.52	10.31	7.51
			SC	8.42	8.71	9.03	8.99	9.11	9.58	8.61	8.55	8.52	8.33	7.48	6.58
			Input	0.77	0.68	0.58	0.61	0.55	0.81	0.84	0.93	1.03	1.09	0.93	0.83
09 (208-230V)	69.8°F (21°C)	59°F (15°C)	TC	9.38	10.33	11.06	10.57	9.95	11.11	11.16	10.79	11.42	9.48	8.12	7.08
			SC	6.81	7.31	7.86	7.61	7.27	7.97	8.00	7.81	8.12	7.18	6.53	4.01
			Input	0.42	0.46	0.42	0.44	0.44	0.66	0.80	0.94	1.23	1.04	0.97	0.99
	75.2°F (24°C)	62.6°F (17°C)	TC	10.22	10.76	11.59	11.30	10.60	12.07	11.83	11.76	12.17	10.17	8.70	7.76
			SC	7.43	7.65	8.18	8.15	7.73	8.50	8.41	8.37	8.55	7.66	7.01	6.65
			Input	0.46	0.50	0.45	0.47	0.47	0.67	0.77	0.94	1.23	1.05	0.98	1.00
	80.6°F (27°C)	66.2°F (19°C)	TC	10.81	11.29	12.20	11.94	11.28	12.62	12.21	12.46	12.86	10.41	8.95	8.10
			SC	7.84	7.99	8.59	8.53	8.51	8.90	8.69	8.78	8.96	7.91	7.26	6.90
			Input	0.50	0.56	0.48	0.52	0.51	0.68	0.73	0.95	1.25	1.06	0.98	1.01
	89.6°F (32°C)	73.4°F (23°C)	TC	12.23	12.35	13.39	13.15	12.81	14.39	15.99	14.26	14.12	11.24	10.03	8.73
			SC	8.15	8.18	8.83	8.75	8.88	9.23	9.82	9.17	9.15	8.02	7.57	7.08
			Input	0.54	0.65	0.56	0.60	0.61	1.08	1.05	0.96	1.27	1.07	1.00	1.01
12 (208-230V)	69.8°F (21°C)	59°F (15°C)	TC	12.08	12.12	12.24	11.97	12.09	12.05	11.58	12.11	11.93	10.59	8.17	7.18
			SC	8.43	8.42	8.47	8.38	8.37	8.32	8.08	8.32	8.24	7.63	6.41	5.97
			Input	0.57	0.59	0.58	0.53	0.37	0.66	1.02	1.10	1.27	1.24	0.95	0.97
	75.2°F (24°C)	62.6°F (17°C)	TC	13.10	13.25	13.26	13.53	12.36	12.45	12.18	12.91	12.67	10.78	8.67	7.73
			SC	9.06	9.08	9.10	9.19	8.60	8.63	8.52	8.86	8.68	7.89	6.88	6.49
			Input	0.69	0.72	0.71	0.71	0.36	0.67	0.76	1.10	1.29	1.24	0.95	0.98
	80.6°F (27°C)	66.2°F (19°C)	TC	13.61	13.79	13.82	14.07	14.91	12.71	12.95	13.75	13.49	11.07	9.20	8.05
			SC	9.38	9.41	9.44	9.50	9.90	8.84	8.98	9.29	9.12	8.14	7.07	6.80
			Input	0.71	0.73	0.72	0.73	0.69	0.68	0.76	1.11	1.30	1.25	0.96	0.98
	89.6°F (32°C)	73.4°F (23°C)	TC	14.77	14.82	14.89	15.18	15.53	14.36	16.88	15.79	14.92	11.84	10.34	8.68
			SC	9.51	9.51	9.54	9.61	9.70	9.22	10.20	9.71	9.41	8.24	7.68	7.07
			Input	0.75	0.76	0.75	0.76	0.70	1.03	1.11	1.78	1.33	1.26	0.97	0.99
18 (208-230V)	69.8°F (21°C)	59°F (15°C)	TC	23.16	23.49	21.85	22.16	21.83	15.81	18.75	17.37	18.16	16.59	11.76	10.12
			SC	16.21	16.44	15.41	15.62	15.45	12.67	13.96	13.35	13.74	12.99	10.86	10.07
			Input	1.17	1.26	1.10	1.19	1.22	1.14	1.31	1.47	1.87	2.05	1.46	1.52
	75.2°F (24°C)	62.6°F (17°C)	TC	23.92	24.19	22.56	22.82	23.27	16.95	19.96	18.38	19.22	17.94	12.61	10.95
			SC	16.74	16.93	16.03	16.25	16.40	13.71	14.90	14.20	14.56	14.09	11.87	10.95
			Input	1.22	1.32	1.15	1.25	1.33	1.18	1.31	1.48	1.89	2.08	1.47	1.53
	80.6°F (27°C)	66.2°F (19°C)	TC	24.60	24.95	23.21	23.54	24.66	18.06	21.18	19.60	20.47	18.94	13.85	11.94
			SC	17.22	17.47	16.51	16.74	17.22	14.71	15.90	15.29	15.62	15.04	13.10	11.94
			Input	1.27	1.40	1.20	1.32	1.44	1.22	1.31	1.48	1.91	2.10	1.48	1.54
	89.6°F (32°C)	73.4°F (23°C)	TC	25.96	25.68	24.49	24.22	27.38	21.43	25.09	21.95	23.15	21.37	15.67	13.48
			SC	18.17	17.97	16.32	16.11	17.66	15.62	16.86	15.81	16.22	15.63	13.79	13.00
			Input	1.37	1.29	1.29	1.22	1.70	1.67	1.54	1.49	1.95	2.14	1.49	1.55
24 (208-230V)	69.8°F (21°C)	59°F (15°C)	TC	23.59	22.13	22.25	22.18	22.21	24.09	21.85	24.10	6.92	20.98	16.16	12.91
			SC	16.51	15.78	15.91	15.81	15.82	16.77	15.60	16.74	4.83	15.19	12.96	11.78
			Input	1.50	1.39	1.41	1.30	1.22	1.12	1.60	2.43	2.65	2.52	2.10	1.79
	75.2°F (24°C)	62.6°F (17°C)	TC	25.51	23.50	24.07	23.34	23.29	24.45	23.50	25.45	24.88	21.95	16.76	13.53
			SC	17.86	16.65	16.94	16.59	16.58	17.10	16.56	17.47	17.25	15.89	13.53	12.15
			Input	1.53	1.43	1.44	1.33	1.25	1.12	1.62	2.46	2.70	2.56	2.12	1.79
	80.6°F (27°C)	66.2°F (19°C)	TC	27.78	26.52	26.21	25.02	24.71	24.69	24.80	26.93	26.41	23.19	17.55	14.08
			SC	19.45	18.57	18.07	17.53	17.41	17.28	17.32	18.28	18.08	16.74	14.25	12.79
			Input	1.58	1.44	1.49	1.36	1.26	1.12	1.61	2.48	2.73	2.58	2.13	1.80
	89.6°F (32°C)	73.4°F (23°C)	TC	30.94	29.79	29.19	28.10	27.60	25.36	32.22	30.43	29.55	25.84	19.36	15.88
			SC	21.66	20.85	18.32	17.99	17.85	16.63	19.48	18.78	18.45	17.05	14.58	13.45
			Input	1.72	1.56	1.62	1.47	1.31	1.11	2.32	2.55	2.82	2.65	2.17	1.82

MODEL	COOLING		OUTDOOR CONDITIONS (DB)												
	Indoor Conditions DB			-13°F	-4°F	0°F	5°F	17°F	47°F	77°F	86°F	95°F	104°F	113°F	122°F
	DB	WB		(-25°C)	(-20°C)	(-17°C)	(-15°C)	(-8°C)	(8°C)	(25°C)	(30°C)	(35°C)	(40°C)	(45°C)	(50°C)
30 (208-230V)	69.8°F (21°C)	59°F (15°C)	TC	N/A	N/A	N/A	28.87	28.78	27.55	26.53	31.03	31.04	30.03	23.54	18.22
			SC	N/A	N/A	N/A	19.71	19.63	18.88	18.83	22.03	22.04	21.32	16.72	12.94
			Input	N/A	N/A	N/A	1.08	1.15	0.82	1.38	1.89	1.90	2.25	2.20	2.10
	75.2°F (24°C)	62.6°F (17°C)	TC	N/A	N/A	N/A	31.07	31.15	27.94	26.49	30.99	31.00	29.99	23.50	18.18
			SC	N/A	N/A	N/A	21.13	21.14	19.51	18.80	22.00	22.01	21.30	16.69	12.91
			Input	N/A	N/A	N/A	1.17	1.20	0.93	1.41	1.92	1.93	2.28	2.23	2.13
	80.6°F (27°C)	66.2°F (19°C)	TC	N/A	N/A	N/A	32.74	32.48	28.52	27.55	27.53	27.54	25.56	23.52	18.20
			SC	N/A	N/A	N/A	21.97	21.81	18.55	18.29	18.95	18.96	19.52	16.23	12.56
			Input	N/A	N/A	N/A	1.24	1.25	0.91	1.44	1.95	1.96	2.31	2.26	2.16
	89.6°F (32°C)	73.4°F (23°C)	TC	N/A	N/A	N/A	35.59	33.75	31.51	30.85	30.94	30.95	29.94	23.45	18.13
			SC	N/A	N/A	N/A	22.05	21.27	21.55	21.94	21.96	21.98	21.26	16.65	12.87
			Input	N/A	N/A	N/A	1.36	1.24	0.95	1.51	2.02	2.03	2.38	2.33	2.23
36 (208-230V)	69.8°F (21°C)	59°F (15°C)	TC	N/A	N/A	N/A	27.82	27.98	30.22	32.51	37.28	37.29	36.06	28.30	20.56
			SC	N/A	N/A	N/A	19.50	19.51	22.22	23.55	26.46	26.48	25.61	20.10	14.60
			Input	N/A	N/A	N/A	1.36	1.24	0.95	1.51	2.02	2.03	2.38	2.33	2.23
	75.2°F (24°C)	62.6°F (17°C)	TC	N/A	N/A	N/A	29.34	29.81	31.22	33.51	37.24	37.25	36.02	28.26	20.52
			SC	N/A	N/A	N/A	20.71	20.89	21.02	22.31	26.43	26.45	25.58	20.07	14.57
			Input	N/A	N/A	N/A	1.19	1.19	2.44	2.87	3.11	3.12	3.99	2.30	2.19
	80.6°F (27°C)	66.2°F (19°C)	TC	N/A	N/A	N/A	30.75	31.01	31.55	33.67	37.26	37.27	36.04	28.28	20.54
			SC	N/A	N/A	N/A	21.59	21.83	21.51	22.41	25.70	25.72	24.87	19.52	14.18
			Input	N/A	N/A	N/A	1.28	1.26	2.45	2.90	3.14	3.15	4.02	2.33	2.22
	89.6°F (32°C)	73.4°F (23°C)	TC	N/A	N/A	N/A	34.59	34.74	35.25	36.20	37.23	37.24	36.01	28.25	20.51
			SC	N/A	N/A	N/A	22.22	22.25	23.55	25.31	26.43	26.44	25.57	20.06	14.56
			Input	N/A	N/A	N/A	1.35	1.31	2.50	2.93	3.17	3.18	4.05	2.36	2.25

LEGEND

- DB - Dry Bulb
- WB - Wet Bulb
- TC - Total Net Capacity (1000 Btu/hour)
- SC - Sensible Capacity (1000 Btu/hour)
- Input - Total Power (kW)

HEATING PERFORMANCE DATA - HIGH WALL

High Wall (Sheet 1 of 2)

MODEL	HEATING INDOOR CONDITIONS DB	OUTDOOR CONDITIONS (DB)												
		-22°F (-30°C)	-13°F (-25°C)	-4°F (-20°C)	0°F (-17°C)	5°F (-15°C)	17°F (-8°C)	19.4°F (-7°C)	24.8°F (-4°C)	32°F (0°C)	39.2°F (4°C)	44.6°F (7°C)	53.6°F (12°C)	
12V (115V)	59°F (15°C)	TC		4.72	5.95	6.15	6.74	8.21	8.38	9.13	10.11	11.42	12.70	13.67
		Input		0.84	0.89	0.84	0.85	0.84	0.85	0.87	0.87	0.96	1.03	1.05
		COP		1.64	1.95	2.15	2.33	2.87	2.89	3.08	3.42	3.50	3.61	3.82
	64.4°F (18°C)	TC		4.58	5.75	5.96	6.19	7.93	7.76	8.88	10.12	11.28	12.39	13.02
		Input		0.86	0.92	0.87	0.91	0.87	0.89	0.90	0.95	0.99	1.06	1.02
		COP		1.55	1.83	2.01	1.99	2.67	2.56	2.88	3.11	3.35	3.42	3.75
	69°F (20.5°C)	TC		4.40	5.13	5.93	6.21	7.86	7.84	8.71	9.47	10.96	12.08	12.73
		Input		0.89	0.85	0.88	0.92	0.91	0.89	0.94	0.92	1.01	1.09	1.05
		COP		1.46	1.76	1.98	1.97	2.53	2.58	2.72	3.02	3.18	3.25	3.56
	71.6°F (22°C)	TC		4.32	5.04	5.74	6.37	7.74	7.78	8.61	9.25	10.77	11.91	12.48
		Input		0.90	0.87	0.90	0.91	0.93	0.91	0.96	0.94	1.03	1.11	1.07
		COP		1.41	1.70	1.87	2.05	2.44	2.51	2.63	2.88	3.08	3.14	3.42
09 (208-230V)	59°F (15°C)	TC	8.09	8.20	7.92	8.92	9.84	11.87	12.23	13.21	14.67	16.09	14.99	16.18
		Input	1.58	1.66	1.22	1.45	1.37	1.54	1.60	1.71	1.81	1.93	1.47	1.50
		COP	1.50	1.44	1.91	1.80	2.11	2.26	2.25	2.26	2.37	2.44	3.00	3.17
	64.4°F (18°C)	TC	7.73	7.93	7.69	8.60	8.69	11.56	11.99	12.95	14.26	15.64	14.31	15.27
		Input	1.58	1.70	1.40	1.33	1.30	1.57	1.64	1.76	1.86	1.99	1.46	1.50
		COP	1.43	1.37	1.68	1.90	1.96	2.15	2.15	2.15	2.24	2.31	2.87	2.99
	69°F (20.5°C)	TC	7.54	7.70	7.34	8.40	9.54	11.59	11.70	12.63	13.91	15.25	13.95	14.39
		Input	1.58	1.73	1.28	1.35	1.42	1.69	1.67	1.81	1.91	2.02	1.49	1.49
		COP	1.40	1.31	1.69	1.82	1.98	2.01	2.05	2.04	2.13	2.22	2.74	2.83
	71.6°F (22°C)	TC	7.41	7.53	7.24	8.53	9.25	11.30	11.62	12.52	13.73	14.09	13.72	14.17
		Input	1.58	1.75	1.29	1.35	1.43	1.63	1.69	1.84	1.93	1.84	1.52	1.52
		COP	1.37	1.26	1.64	1.85	1.90	2.03	2.01	1.99	2.08	2.24	2.65	2.74
12 (208-230V)	59°F (15°C)	TC	8.08	7.40	9.98	11.16	12.10	12.96	14.48	14.74	15.37	14.30	14.96	16.71
		Input	1.58	1.65	7.88	1.96	1.99	1.73	1.93	1.82	1.75	1.66	1.33	1.42
		COP	1.50	1.31	1.52	1.67	1.78	2.19	2.20	2.37	2.58	2.52	3.31	3.44
	64.4°F (18°C)	TC	8.38	8.65	8.98	11.01	11.53	13.71	14.27	15.71	14.97	14.13	14.44	15.83
		Input	1.58	1.68	1.79	1.97	1.85	1.90	1.98	2.23	1.79	1.74	1.37	1.43
		COP	1.55	1.51	1.47	1.64	1.83	2.11	2.11	2.07	2.45	2.38	3.09	3.24
	69°F (20.5°C)	TC	8.10	8.46	9.86	11.34	11.40	13.64	13.93	15.17	15.00	15.49	13.96	15.00
		Input	1.58	1.71	1.91	1.97	2.03	1.98	2.03	2.21	1.93	1.82	1.40	1.43
		COP	1.50	1.45	1.51	1.68	1.64	2.02	2.01	2.01	2.28	2.50	2.93	3.07
	71.6°F (22°C)	TC	7.98	8.34	9.83	9.81	11.53	13.54	13.93	14.90	14.91	15.26	13.76	14.86
		Input	1.58	1.73	1.82	1.79	2.05	2.02	2.04	2.27	2.04	1.86	1.40	1.48
		COP	1.48	1.42	1.58	1.61	1.65	1.96	2.00	1.93	2.15	2.41	2.89	2.94
18 (208-230V)	59°F (15°C)	TC	13.36	15.43	17.93	19.58	20.74	22.72	23.44	25.31	25.93	27.88	23.03	25.18
		Input	1.58	2.99	3.06	3.21	3.22	3.01	2.99	3.11	2.90	2.98	1.89	1.96
		COP	2.48	1.51	1.72	1.79	1.89	2.21	2.30	2.39	2.62	2.74	3.57	3.77
	64.4°F (18°C)	TC	13.01	15.27	17.55	19.27	20.39	22.57	23.02	24.85	25.31	27.21	22.44	24.70
		Input	1.58	3.08	3.13	3.29	3.31	3.06	3.08	3.20	2.98	3.06	1.96	2.04
		COP	2.41	1.45	1.65	1.72	1.80	2.16	2.19	2.28	2.49	2.60	3.35	3.56
	69°F (20.5°C)	TC	12.63	15.32	17.38	19.21	20.11	22.22	22.61	24.45	24.81	26.76	21.77	24.41
		Input	1.58	3.11	3.14	3.32	3.38	3.12	3.15	3.28	3.05	3.15	2.01	2.11
		COP	2.34	1.44	1.62	1.69	1.74	2.09	2.11	2.19	2.38	2.49	3.17	3.39
	71.6°F (22°C)	TC	12.41	15.24	17.22	19.01	20.12	22.00	22.48	24.17	24.59	26.38	21.39	24.21
		Input	1.58	3.16	3.19	3.37	3.38	3.17	3.20	3.32	3.10	3.19	2.04	2.15
		COP	2.30	1.41	1.58	1.65	1.74	2.03	2.06	2.13	2.32	2.43	3.07	3.29
24 (208-230V)	59°F (15°C)	TC	16.94	16.55	21.12	21.85	23.33	25.04	23.73	24.59	27.04	33.04	31.38	34.02
		Input	1.58	3.55	3.92	3.64	3.76	3.51	3.09	3.17	3.21	3.89	3.21	3.21
		COP	3.14	1.36	2.07	1.76	1.82	2.09	2.25	2.27	2.47	2.49	2.87	3.10
	64.4°F (18°C)	TC	16.45	16.19	20.90	21.33	22.74	24.43	23.19	23.58	26.65	31.56	30.45	32.85
		Input	1.58	3.71	4.19	3.78	3.91	3.63	3.19	3.24	3.42	3.94	3.32	3.32
		COP	3.05	1.28	1.46	1.65	1.71	1.97	2.13	2.13	2.28	2.35	2.69	2.90
	69°F (20.5°C)	TC	15.93	15.90	19.65	21.04	22.51	24.05	22.62	24.65	27.34	30.77	29.50	31.77
		Input	1.58	4.66	4.06	3.91	4.04	3.75	3.30	3.48	3.81	4.02	3.39	3.38
		COP	2.95	1.21	1.97	1.58	1.63	1.88	2.01	2.08	2.10	2.24	2.55	2.76
	71.6°F (22°C)	TC	15.57	15.77	20.33	20.64	22.21	23.67	22.16	24.82	27.02	30.15	28.83	30.80
		Input	1.58	3.95	4.44	4.02	4.14	3.82	3.35	3.57	3.87	4.08	3.41	3.35
		COP	2.89	1.17	1.34	1.51	1.57	1.81	1.94	2.04	2.04	2.17	2.48	2.69

High Wall (Sheet 2 of 2)

MODEL	HEATING		OUTDOOR CONDITIONS (DB)											
	INDOOR CONDITIONS DB		-22°F (-30°C)	-13°F (-25°C)	-4°F (-20°C)	0°F (-17°C)	5°F (-15°C)	17°F (-8°C)	19.4°F (-7°C)	24.8°F (-4°C)	32°F (0°C)	39.2°F (4°C)	44.6°F (7°C)	53.6°F (12°C)
30 (208-230V)	59°F (15°C)	TC		N/A	N/A	N/A	18.93	23.16	23.22	23.42	23.56	25.85	27.79	28.60
		Input		N/A	N/A	N/A	2.17	2.24	2.23	2.20	2.21	2.24	2.25	2.00
		COP		N/A	N/A	N/A	2.56	3.03	3.05	3.12	3.12	3.38	3.62	4.19
	64.4°F (18°C)	TC		N/A	N/A	N/A	17.45	20.45	22.52	23.40	23.54	24.52	27.61	27.62
		Input		N/A	N/A	N/A	2.16	2.21	2.23	2.32	2.35	2.35	2.45	2.24
		COP		N/A	N/A	N/A	2.37	2.71	2.96	2.95	2.93	3.06	3.30	3.61
	69°F (20.5°C)	TC		N/A	N/A	N/A	16.38	19.61	21.85	22.98	24.63	26.75	30.08	31.02
		Input		N/A	N/A	N/A	2.18	2.20	2.25	2.42	2.58	2.64	2.74	2.39
		COP		N/A	N/A	N/A	2.20	2.61	2.84	2.78	2.80	2.97	3.21	3.80
	71.6°F (22°C)	TC		N/A	N/A	N/A	16.24	19.54	21.67	22.54	23.41	24.21	30.06	31.05
		Input		N/A	N/A	N/A	2.17	2.24	2.23	2.20	2.21	2.24	2.25	2.00
		COP		N/A	N/A	N/A	2.19	2.56	2.85	3.00	3.10	3.17	3.91	4.55
36 (208-230V)	59°F (15°C)	TC		N/A	N/A	N/A	18.93	23.16	25.32	30.21	35.68	37.02	39.20	40.01
		Input		N/A	N/A	N/A	2.17	3.25	0.14	3.21	3.42	3.58	3.71	3.74
		COP		N/A	N/A	N/A	2.56	2.09	53.00	2.76	3.06	3.03	3.09	3.13
	64.4°F (18°C)	TC		N/A	N/A	N/A	17.45	20.45	24.52	28.65	34.56	36.02	37.85	39.20
		Input		N/A	N/A	N/A	2.16	3.26	3.05	3.25	3.58	3.62	3.78	3.81
		COP		N/A	N/A	N/A	2.37	1.84	2.35	2.58	2.83	2.91	2.93	3.01
	69°F (20.5°C)	TC		N/A	N/A	N/A	16.38	19.61	23.85	27.65	34.01	35.85	36.85	38.20
		Input		N/A	N/A	N/A	3.21	3.28	3.02	3.02	3.62	3.74	3.81	3.84
		COP		N/A	N/A	N/A	1.49	1.75	2.31	2.68	2.75	2.81	2.83	2.91
	71.6°F (22°C)	TC		N/A	N/A	N/A	17.25	20.12	23.21	26.32	33.52	35.61	36.01	37.20
		Input		N/A	N/A	N/A	2.17	3.31	2.43	3.21	3.74	3.85	3.98	4.01
		COP		N/A	N/A	N/A	2.33	1.78	2.80	2.40	2.62	2.71	2.65	2.72

LEGEND

- DB - Dry Bulb
- WB - Wet Bulb
- TC - Total Net Capacity (1000 Btu/hour)
- Input - Total Power (kW)
- COP - W/W

COOLING PERFORMANCE DATA - CASSETTE

MODEL	COOLING			OUTDOOR CONDITIONS (DB)											
	Indoor Conditions DB			-13°F (-25°C)	-4°F (-20°C)	0°F (-17°C)	5°F (-15°C)	17°F (-8°C)	47°F (8°C)	77°F (25°C)	86°F (30°C)	95°F (35°C)	104°F (40°C)	113°F (45°C)	122°F (50°C)
	DB	WB													
09 (208-230V)	69.8°F (21°C)	59°F (15°C)	TC	6.31	5.92	5.55	5.45	5.69	6.90	9.92	10.71	10.67	9.19	7.86	6.90
			SC	5.11	4.78	4.56	4.55	4.76	5.99	7.48	7.80	7.81	7.12	6.47	5.99
			Input	0.17	0.13	0.10	0.09	0.11	1.02	0.68	0.85	1.12	1.05	9.87	1.02
	75.2°F (24°C)	62.6°F (17°C)	TC	7.53	7.10	7.11	6.88	8.90	10.42	9.98	11.55	11.79	9.87	8.41	7.38
			SC	6.10	5.59	5.63	5.48	6.65	7.91	7.51	8.36	8.51	7.64	6.93	6.41
			Input	0.16	0.14	0.14	0.13	0.18	0.55	0.66	0.96	1.24	1.06	1.00	0.97
	80.6°F (27°C)	66.2°F (19°C)	TC	9.75	9.20	8.95	8.91	9.40	12.09	12.11	12.41	12.59	10.33	8.87	7.91
			SC	7.90	6.91	6.76	6.78	6.93	8.85	8.85	8.99	9.02	7.93	7.18	6.75
			Input	0.25	0.22	0.22	0.22	0.19	0.73	0.77	0.97	1.05	1.07	1.00	1.04
	89.6°F (32°C)	73.4°F (23°C)	TC	11.62	10.97	10.53	10.46	12.71	14.45	15.84	14.12	13.99	11.65	9.91	9.06
			SC	9.42	7.54	7.31	7.30	8.29	9.50	10.07	9.47	9.32	8.29	7.41	7.08
			Input	0.34	0.31	0.28	0.28	0.37	1.20	1.04	0.97	1.28	1.09	1.02	1.06
12 (208-230V)	69.8°F (21°C)	59°F (15°C)	TC	12.42	11.72	11.68	12.30	12.50	11.72	11.59	12.74	12.58	10.64	7.80	7.19
			SC	10.06	8.69	8.68	8.94	9.03	8.65	8.65	9.21	9.10	8.15	6.66	6.06
			Input	0.57	0.50	0.56	0.65	0.83	0.74	0.80	1.16	1.35	1.31	0.95	1.31
	75.2°F (24°C)	62.6°F (17°C)	TC	14.37	13.55	13.02	13.24	13.40	11.95	12.35	13.57	13.28	10.90	8.65	7.85
			SC	11.64	9.73	9.50	9.53	9.74	8.85	9.22	9.78	9.61	8.39	7.51	7.13
			Input	0.82	0.72	0.72	0.73	0.99	0.74	0.80	1.17	1.37	1.32	1.01	1.04
	80.6°F (27°C)	66.2°F (19°C)	TC	14.81	13.98	13.55	13.48	13.66	12.22	13.15	14.48	13.82	10.94	9.03	7.88
			SC	12.00	9.99	9.90	9.75	10.05	9.05	9.77	10.33	10.02	8.35	7.90	7.51
			Input	0.84	0.75	0.74	0.73	1.03	0.07	0.80	1.18	1.38	1.32	1.02	1.05
	89.6°F (32°C)	73.4°F (23°C)	TC	15.23	14.36	14.12	14.09	13.93	14.04	16.49	16.18	15.48	12.34	9.92	8.69
			SC	12.33	9.72	9.77	9.61	9.80	9.55	10.70	10.74	11.04	9.04	8.16	7.73
			Input	0.85	0.75	0.75	0.74	0.97	1.15	1.16	1.19	1.41	1.35	1.00	1.06
18 (208-230V)	69.8°F (21°C)	59°F (15°C)	TC	13.78	13.00	12.51	12.91	13.28	16.32	7.21	15.35	16.45	14.99	10.98	9.23
			SC	11.16	9.90	9.65	9.86	9.60	4.90	5.49	10.58	9.08	10.40	4.90	5.09
			Input	0.44	0.39	0.34	0.39	0.49	3.29	0.41	1.45	1.81	2.22	2.24	1.82
	75.2°F (24°C)	62.6°F (17°C)	TC	16.06	15.15	15.18	15.09	15.54	17.64	16.76	16.55	17.66	16.35	12.19	10.10
			SC	13.01	11.16	11.14	11.13	10.85	11.95	11.53	11.26	9.59	6.83	5.44	5.12
			Input	0.62	0.55	0.56	0.55	0.42	1.49	1.14	1.46	1.85	2.39	2.24	1.98
	80.6°F (27°C)	66.2°F (19°C)	TC	18.05	17.03	17.48	17.19	19.54	18.56	18.91	17.84	18.81	17.51	12.69	10.99
			SC	14.62	12.19	12.32	12.20	12.77	12.51	14.92	11.95	10.10	11.86	4.95	5.18
			Input	0.80	0.70	0.79	0.75	0.91	1.55	1.27	1.46	1.86	2.03	2.56	2.12
	89.6°F (32°C)	73.4°F (23°C)	TC	23.80	22.45	22.68	23.77	21.61	21.67	22.88	20.20	21.48	19.81	15.25	12.85
			SC	19.28	13.79	13.79	14.19	13.07	13.22	13.47	13.75	11.23	12.16	10.55	5.23
			Input	1.46	1.29	1.41	1.39	1.10	1.68	1.52	1.47	1.91	2.07	1.65	2.46
24 (208-230V)	69.8°F (21°C)	59°F (15°C)	TC	19.25	18.16	18.25	17.19	17.43	22.95	19.47	18.78	20.68	20.04	15.35	11.63
			SC	15.59	14.71	14.77	14.16	14.33	17.00	15.41	15.19	16.03	15.74	13.24	11.31
			Input	0.60	0.54	0.56	0.41	0.55	1.04	1.47	1.63	2.24	2.59	2.03	1.63
	75.2°F (24°C)	62.6°F (17°C)	TC	2.26	2.13	2.168	20.61	19.01	24.10	20.87	24.59	23.93	22.68	16.31	12.17
			SC	1.83	16.72	16.89	16.32	15.58	17.85	16.48	18.31	17.98	17.34	14.22	11.99
			Input	0.88	0.78	0.86	0.62	0.63	1.05	1.47	2.52	2.75	3.01	2.05	1.64
	80.6°F (27°C)	66.2°F (19°C)	TC	28.33	26.72	24.38	23.15	23.13	24.90	22.19	26.29	25.30	24.28	17.27	12.94
			SC	22.94	19.63	18.54	17.91	18.05	18.54	17.57	19.38	18.89	18.44	15.06	12.74
			Input	1.60	1.42	1.09	0.81	1.00	1.06	1.47	2.55	2.79	3.05	2.07	1.65
	89.6°F (32°C)	73.4°F (23°C)	TC	30.37	28.65	29.74	29.39	24.88	26.25	31.26	28.81	28.33	27.29	19.13	14.57
			SC	24.60	15.45	20.25	20.10	18.45	18.40	20.75	19.85	19.58	19.22	15.85	13.60
			Input	1.68	1.49	1.43	1.30	1.07	1.04	2.37	2.38	2.85	3.14	2.11	1.66

LEGEND

DB - Dry Bulb
 WB - Wet Bulb
 TC - Total Net Capacity (1000 Btu/hour)
 SC - Sensible Capacity (1000 Btu/hour)
 Input - Total Power (kW)

HEATING PERFORMANCE DATA - CASSETTE

MODEL	HEATING		OUTDOOR CONDITIONS (DB)											
	Indoor Conditions DB		-22°F (-30°C)	-13°F (-25°C)	-4°F (-20°C)	0°F (-17°C)	5°F (-15°C)	17°F (-8°C)	19.4°F (-7°C)	24.8°F (-4°C)	32°F (0°C)	39.2°F (4°C)	44.6°F (7°C)	53.6°F (12°C)
09 (208-230V)	59°F (15°C)	TC	7.24	8.76	10.71	11.87	12.37	14.12	14.75	15.12	15.22	16.50	15.64	17.10
		Input	1.55	1.65	1.76	1.90	1.85	1.97	2.12	2.03	2.04	1.99	1.50	1.53
		COP	4.66	5.30	6.09	6.23	6.67	7.16	6.96	7.43	7.47	8.28	10.44	11.15
	64.4°F (18°C)	TC	7.02	8.57	10.54	11.66	12.01	14.18	14.63	14.82	13.96	15.96	15.11	16.46
		Input	1.58	1.66	1.79	1.94	1.90	2.13	2.13	2.14	1.90	1.99	1.49	1.53
		COP	4.43	5.16	5.88	6.01	6.33	6.67	6.86	6.93	7.34	8.03	10.14	10.77
	69°F (20.5°C)	TC	6.89	8.83	10.27	11.44	11.87	14.13	14.51	14.60	14.44	15.32	14.85	15.85
		Input	1.61	1.69	1.82	1.98	1.94	2.17	2.20	2.12	2043.00	1.91	1517.00	1.53
		COP	4.29	5.23	5.64	5.78	6.12	6.52	6.61	6.89	0.01	8.03	0.01	10.33
	71.6°F (22°C)	TC	5.12	6.62	8.31	9.26	7.96	11.91	12.28	13.25	14.49	14.80	14.38	15.47
		Input	1.13	1.19	1.32	1.44	1.32	1.74	1.81	1.94	2.09	1.87	1.55	1.54
		COP	4.54	5.57	6.28	6.42	6.02	6.85	6.79	6.83	6.92	7.92	9.31	10.05
12 (208-230V)	59°F (15°C)	TC	7.23	8.12	10.08	10.95	11.56	13.31	14.57	15.59	15.10	16.40	15.72	17.27
		Input	1.52	1.66	1.80	1.71	1.74	1.99	2.05	2.01	1.64	1.61	1.33	1.27
		COP	4.76	4.89	5.59	6.39	6.65	6.67	7.11	7.76	9.20	10.21	11.80	13.60
	64.4°F (18°C)	TC	7.11	8.46	9.41	10.97	12.30	14.05	14.75	16.29	15.23	16.64	15.69	16.78
		Input	1.56	1.74	1.69	1.95	1.90	1.96	2.02	2.10	1611.00	1.63	1.34	1.31
		COP	4.55	4.88	5.57	5.62	6.46	7.18	7.30	7.63	9.45	10.24	11.72	12.79
	69°F (20.5°C)	TC	7.05	8.26	9.63	11.54	12.02	14.57	15.06	16.16	14.59	16.35	15.26	16.28
		Input	1.62	1.79	1.88	1.90	1.94	1.95	2.02	2.12	1.63	1.68	1.38	1.35
		COP	4.35	4.61	5.12	6.08	6.19	7.48	7.46	7.62	8.93	9.73	11.07	12.05
	71.6°F (22°C)	TC	6.97	8.23	9.42	10.64	12.47	14.44	14.85	16.40	13.86	16.10	15.03	15.84
		Input	1.65	1.82	1.90	1.79	1.91	1.99	2.04	2.10	1.62	1.72	1.40	1.38
		COP	4.22	4.53	4.97	5.95	6.53	7.25	7.27	7.80	8.54	9.34	10.73	11.45
18 (208-230V)	59°F (15°C)	TC	NA	17.66	14.03	15.30	16.40	22.34	18.19	19.74	21.52	23.64	21.70	22.57
		Input	NA	2.96	3.55	2.87	3.53	3.69	3.52	3.32	2.70	2.91	2.34	2.07
		COP	NA	1.75	1.19	1.60	1.40	1.80	1.70	1.74	2.34	2.40	2.70	3.20
	64.4°F (18°C)	TC	NA	16.87	14.10	18.30	15.85	22.05	20.79	19.31	20.92	23.47	21.85	21.74
		Input	NA	3.04	2.88	3.45	2.78	3.65	3.70	3.48	2.80	2.85	2.31	2.12
		COP	NA	1.62	1.43	1.60	1.70	1.80	1.65	1.63	2.19	2.40	2.80	3.00
	69°F (20.5°C)	TC	NA	12.56	12.99	14.19	15.71	16.41	16.76	16.84	21.18	22.97	21.14	21.02
		Input	NA	3.08	2.81	3.37	2.43	2.61	2.61	3.31	2.77	2.93	2.36	2.20
		COP	NA	1.19	1.35	1.20	1.90	1.90	1.90	1.50	2.24	2.30	2.60	2.80
	71.6°F (22°C)	TC	NA	9.56	11.14	13.09	13.75	17.19	17.62	18.29	20.74	22.65	20.54	20.72
		Input	NA	2.21	2.42	2.32	2.42	2.64	2.70	2.62	2.81	2.97	2.38	2.25
		COP	NA	1.27	1.35	1.70	1.70	1.90	1.90	2.00	2.16	2.20	2.50	2.70
24 (208-230V)	59°F (15°C)	TC	15.01	18.89	23.64	26.12	25.70	29.31	29.18	31.17	29.65	33.71	33.06	34.64
		Input	3.22	3.57	4.16	4.40	4.00	4.05	3.91	4.05	3.36	3.69	3.16	3.01
		COP	1.37	1.55	1.66	1.74	1.88	2.12	2.19	2.25	2.59	2.68	3.07	3.37
	64.4°F (18°C)	TC	14.95	18.82	23.31	24.17	25.15	28.92	28.77	30.50	28.72	33.27	32.20	33.40
		Input	3.28	3.66	4.29	4.14	4.07	4.25	4.06	4.21	3.45	3.84	3.26	3.09
		COP	1.33	1.51	1.59	1.71	1.81	2.00	2.08	2.15	2.44	2.54	2.90	3.17
	69°F (20.5°C)	TC	14.68	18.50	23.01	22.84	24.57	28.54	28.36	30.05	29.84	32.51	31.39	30.99
		Input	3.37	3.75	4.41	3.94	4.13	4.40	4.20	4.37	3.71	3.93	3.34	3.02
		COP	1.28	1.44	1.53	1.70	1.74	1.90	1.98	2.02	2.35	2.43	2.75	3.01
	71.6°F (22°C)	TC	14.50	18.84	22.13	22.04	24.32	27.23	29.78	29.78	29.48	32.16	30.88	30.48
		Input	3.44	3.88	4.29	3.83	4.18	4.22	4.46	4.46	3.78	4.00	3.40	3.08
		COP	1.24	1.42	1.51	1.69	1.70	1.89	1.96	1.96	2.29	2.36	2.66	2.90

LEGEND

DB - Dry Bulb
 WB - Wet Bulb
 TC - Total Net Capacity (1000 Btu/hour)
 Input - Total Power (kW)
 COP - W/W

COOLING PERFORMANCE DATA - DUCTED

MODEL	COOLING			OUTDOOR CONDITIONS (DB)											
	Indoor Conditions DB			-13°F (-25°C)	-4°F (-20°C)	0°F (-17°C)	5°F (-15°C)	17°F (-8°C)	47°F (8°C)	77°F (25°C)	86°F (30°C)	95°F (35°C)	104°F (40°C)	113°F (45°C)	122°F (50°C)
	DB	WB													
09 (208-230V)	69.8°F (21°C)	59°F (15°C)	TC	11.55	10.60	10.89	9.84	10.36	11.29	11.16	11.03	11.33	9.45	8.10	7.31
			SC	8.09	7.09	7.32	8.67	7.03	7.55	7.42	7.41	7.54	6.67	6.01	5.67
			Input	0.39	0.36	0.42	0.40	0.45	0.64	0.82	0.97	1.25	1.07	1.02	1.06
	75.2°F (24°C)	62.6°F (17°C)	TC	12.35	11.24	11.52	10.53	11.00	12.09	11.37	11.32	12.10	9.71	8.55	7.82
			SC	8.64	7.45	7.75	9.41	7.42	8.05	7.51	7.66	7.91	6.94	6.40	6.08
			Input	0.39	0.38	0.45	0.41	0.47	0.69	0.75	0.97	1.26	1.08	1.03	1.06
	80.6°F (27°C)	66.2°F (19°C)	TC	13.02	11.75	12.19	11.16	11.62	12.54	12.25	11.66	12.77	10.05	8.96	8.23
			SC	9.12	7.68	8.09	10.07	7.72	8.24	8.09	7.86	8.25	7.21	6.73	6.46
			Input	0.39	0.41	0.49	0.43	0.50	0.66	0.75	0.97	1.27	1.09	1.04	1.07
	89.6°F (32°C)	73.4°F (23°C)	TC	13.98	12.63	13.38	12.85	12.39	14.50	15.61	12.62	13.70	10.99	9.86	9.03
			SC	9.78	7.70	8.33	8.35	7.73	8.61	9.04	7.96	8.29	7.34	6.91	6.64
			Input	0.40	0.45	0.55	0.46	0.52	1.07	1.08	0.98	1.29	1.11	1.05	1.08
12 (208-230V)	69.8°F (21°C)	59°F (15°C)	TC	11.00	10.26	11.11	11.05	10.37	11.23	10.91	11.84	10.79	10.12	7.83	6.82
			SC	7.70	8.55	7.73	7.70	7.34	7.79	7.60	8.07	7.56	7.23	6.14	5.66
			Input	0.80	0.92	1.08	1.05	0.82	0.72	0.81	1.15	1.13	1.30	1.01	1.04
	75.2°F (24°C)	62.6°F (17°C)	TC	12.36	11.99	11.57	12.10	11.34	11.48	11.64	12.60	12.12	10.62	8.04	7.32
			SC	8.65	8.18	8.03	8.26	7.95	7.96	8.03	8.50	8.33	7.58	6.46	6.12
			Input	0.95	1.11	1.17	1.04	0.95	0.73	0.81	1.16	1.34	1.32	1.01	1.05
	80.6°F (27°C)	66.2°F (19°C)	TC	13.21	12.44	11.98	12.73	11.87	11.66	12.37	13.35	12.95	11.07	8.21	7.76
			SC	9.25	8.41	8.26	8.59	2.42	8.09	8.40	8.84	8.72	7.20	6.69	6.48
			Input	0.97	1.19	1.27	1.12	0.91	0.73	0.81	1.17	1.37	1.33	1.02	1.06
	89.6°F (32°C)	73.4°F (23°C)	TC	14.37	13.01	13.45	13.65	12.95	13.25	16.06	15.12	14.09	11.80	9.04	8.54
			SC	10.06	8.35	8.46	8.54	8.28	8.37	9.50	9.11	6.64	7.85	6.88	6.74
			Input	0.98	1.33	1.27	1.26	0.89	1.08	1.16	1.19	1.39	1.35	1.02	1.07
18 (208-230V)	69.8°F (21°C)	59°F (15°C)	TC	16.46	15.76	14.12	13.98	15.22	14.77	16.28	16.15	16.14	12.41	10.64	8.84
			SC	11.52	10.78	9.80	9.70	10.76	10.51	11.21	11.14	11.17	9.25	8.44	7.68
			Input	1.29	0.81	0.68	0.70	0.55	1.02	1.25	1.48	1.82	1.45	1.45	1.48
	75.2°F (24°C)	62.6°F (17°C)	TC	17.64	17.73	17.19	18.63	19.64	15.44	17.48	17.22	17.29	13.30	11.55	9.52
			SC	12.35	11.72	11.41	11.98	13.02	10.98	11.88	11.71	11.81	9.89	9.19	8.28
			Input	1.31	1.11	1.22	1.41	0.78	1.02	1.26	1.49	1.85	1.46	1.45	1.49
	80.6°F (27°C)	66.2°F (19°C)	TC	18.78	18.41	18.98	16.64	22.67	16.38	18.58	18.31	18.42	14.33	12.47	10.22
			SC	13.15	12.03	12.25	11.01	14.41	11.46	12.42	12.26	12.34	10.51	9.83	8.84
			Input	1.32	1.20	1.41	1.14	1.23	1.05	1.26	1.50	1.87	1.48	1.47	1.50
	89.6°F (32°C)	73.4°F (23°C)	TC	21.38	20.33	20.99	20.54	24.92	20.08	22.46	20.69	20.96	16.28	14.30	12.07
			SC	14.97	12.05	12.31	11.99	14.36	12.33	13.33	12.57	12.71	10.86	10.34	9.46
			Input	1.36	1.27	1.48	1.39	1.33	1.46	1.52	1.53	1.91	1.49	1.48	1.53
24 (208-230V)	69.8°F (21°C)	59°F (15°C)	TC	26.44	24.94	23.66	23.49	23.35	21.39	22.44	26.66	25.92	22.16	15.23	11.91
			SC	18.51	18.34	17.78	17.68	17.68	16.69	17.12	19.06	18.77	17.02	13.16	11.57
			Input	1.43	1.57	1.33	1.25	1.14	0.73	1.49	2.55	2.80	2.63	2.03	1.67
	75.2°F (24°C)	62.6°F (17°C)	TC	27.96	26.08	25.67	26.34	25.83	24.24	23.84	27.77	27.41	23.61	16.46	12.91
			SC	19.57	19.25	19.12	19.41	19.24	18.15	18.22	19.92	19.79	18.11	14.41	12.75
			Input	1.45	1.50	1.44	1.46	1.34	1.06	1.49	2.49	2.84	2.67	2.06	1.66
	80.6°F (27°C)	66.2°F (19°C)	TC	29.14	27.26	26.85	27.68	27.09	24.54	25.15	30.03	28.57	25.44	17.68	13.52
			SC	20.40	20.04	19.98	20.30	20.12	18.41	19.14	21.11	20.63	19.15	15.27	13.31
			Input	1.46	1.54	1.48	1.51	1.36	1.06	1.47	2.61	2.86	3.07	2.08	1.67
	89.6°F (32°C)	73.4°F (23°C)	TC	32.85	29.46	29.45	29.94	29.29	24.95	35.47	33.03	32.21	28.75	19.09	14.95
			SC	23.00	20.30	20.36	20.62	20.32	17.85	22.27	21.37	21.18	19.88	15.64	13.92
			Input	1.50	1.58	1.59	1.60	1.41	1.05	2.42	2.55	2.94	3.17	2.10	1.68

LEGEND

DB - Dry Bulb
 WB - Wet Bulb
 TC - Total Net Capacity (1000 Btu/hour)
 SC - Sensible Capacity (1000 Btu/hour)
 Input - Total Power (kW)

HEATING PERFORMANCE DATA - DUCTED

Model	HEATING		OUTDOOR CONDITIONS (DB)											
	Indoor Conditions DB		-22°F (-30°C)	-13°F (-25°C)	-4°F (-20°C)	0°F (-17°C)	5°F (-15°C)	17°F (-8°C)	19.4°F (-7°C)	24.8°F (-4°C)	32°F (0°C)	39.2°F (4°C)	44.6°F (7°C)	53.6°F (12°C)
09 (208-230V)	59°F (15°C)	TC	6.91	8.83	10.79	12.10	12.24	14.18	15.21	15.19	15.94	17.24	15.35	16.38
		Input	1.66	1.73	1.77	1.85	1.82	1.93	1.99	1.92	1.71	1.76	1.36	1.37
		COP	1.23	1.50	1.79	1.92	1.97	2.15	2.25	2.32	2.73	2.87	3.31	3.50
	64.4°F (18°C)	TC	6.70	8.69	10.58	11.19	11.94	14.32	14.87	15.19	15.94	16.77	14.98	16.06
		Input	1.70	1.76	1.81	1.85	1.92	2.02	2.04	1.92	1.71	1821.33	1.42	1.41
		COP	1.16	1.45	1.71	1.77	1.82	2.08	2.14	2.32	2.73	2.70	3.10	3.33
	69°F (20.5°C)	TC	6.60	8.71	10.28	11.63	11.76	14.10	14.58	14.79	14.90	15.58	14.52	15.67
		Input	1.71	1.75	1.84	1.92	1.94	2.05	2.08	1.96	1.77	1.91	1.45	1.51
		COP	1.13	1.45	1.64	1.77	1.77	2.01	2.05	2.21	2.46	2.39	2.93	3.05
	71.6°F (22°C)	TC	6.88	8.55	9.96	11.33	11.57	14.03	14.47	14.24	14.74	15.58	14.21	15.42
		Input	1.68	1.77	1.85	1.94	1.94	2.09	2.15	1.99	1.81	1.91	1.47	1.54
		COP	1.20	1.41	1.58	1.71	1.75	1.96	1.97	2.09	2.39	2.39	2.83	2.94
12 (208-230V)	59°F (15°C)	TC	6.70	7.20	8.89	11.21	12.32	14.79	15.18	15.80	15.64	16.65	15.60	16.84
		Input	1.68	1.68	1.89	1.96	1.84	2.04	2.07	2.04	1.72	1.74	1.41	1.40
		COP	1.17	1.25	1.36	1.68	1.96	2.13	2.15	2.27	2.67	2.81	3.25	3.52
	64.4°F (18°C)	TC	7.13	8.51	7.45	10.86	12.10	14.56	15.06	15.65	15.29	16.35	15.13	16.41
		Input	1.67	1.77	2.18	2.18	1.89	2.10	2.15	2.12	1.77	1.80	1.45	1.45
		COP	1.26	1.33	1.16	1.46	1.88	2.04	2.05	2.16	2.53	2.66	3.06	3.32
	69°F (20.5°C)	TC	6.94	8.34	9.54	11.06	11.88	14.34	14.82	15.32	14.98	15.93	14.81	16.00
		Input	1.68	1.80	1.95	2.02	1.92	2.15	2.21	2.15	1.81	1.85	1.49	1.48
		COP	1.21	1.35	1.44	1.60	1.81	1.95	1.96	2.08	2.43	2.53	2.91	3.16
	71.6°F (22°C)	TC	6.89	8.32	8.66	10.70	11.71	14.22	14.64	15.16	14.78	15.73	14.51	15.74
		Input	1.67	1.82	1.77	1.94	1.95	2.18	2.25	2.20	1.84	1.88	1.51	1.51
		COP	1.21	1.34	7.84	1.62	1.76	1.91	1.91	2.02	2.36	2.45	2.83	3.06
18 (208-230V)	59°F (15°C)	TC	14.66	15.76	18.65	18.67	20.02	22.76	23.80	25.56	22.52	22.87	22.90	24.38
		Input	10.35	10.78	11.40	11.26	11.78	11.43	11.84	12.17	8.80	8.40	7.28	7.06
		COP	1.42	1.46	1.64	1.66	1.70	1.99	2.01	2.10	2.56	2.72	3.15	3.46
	64.4°F (18°C)	TC	14.89	17.73	18.51	17.93	18.40	19.91	23.16	24.93	20.47	20.13	22.07	23.53
		Input	11.26	11.72	11.90	10.99	11.88	10.78	12.04	12.66	8.86	8.25	7.56	7.31
		COP	1.32	1.11	1.56	1.63	1.54	1.85	1.92	1.97	2.31	2.44	2.92	3.22
	69°F (20.5°C)	TC	13.99	18.41	18.27	19.03	16.60	21.63	22.92	22.22	19.30	23.03	21.42	22.69
		Input	11.55	12.03	12.34	12.56	11.24	12.33	12.61	11.24	8.85	9.63	7.82	7.56
		COP	1.21	1.20	1.48	1.52	1.48	1.75	1.82	1.98	2.18	2.39	2.74	3.00
	71.6°F (22°C)	TC	16.87	20.33	18.15	16.70	18.28	22.03	22.30	22.00	0.00	21.65	20.93	21.83
		Input	11.57	12.05	12.58	11.56	12.61	12.64	12.73	11.50	0.00	9.47	7.96	7.73
		COP	1.46	1.27	1.44	1.44	1.45	1.74	1.75	1.91	/?	2.29	2.63	2.83
24 (208-230V)	59°F (15°C)	TC	16.78	0.02	0.03	0.03	0.03	31.76	32.25	33.01	35.90	38.04	36.57	37.56
		Input	3.12	0.00	0.00	0.00	0.00	3.82	3.69	3.76	3.61	3.50	3.01	2.80
		COP	1.58	1.72	1.98	2.18	2.24	2.44	2.56	2.57	2.92	3.18	3.56	3.93
	64.4°F (18°C)	TC	16.34	20.36	25.32	27.78	29.76	30.86	31.59	32.25	35.23	37.08	35.86	36.56
		Input	3.20	3.64	3.95	3.96	4.10	3.93	3.82	3.89	3.74	3.62	3.13	2.91
		COP	1.50	1.64	1.88	2.06	2.13	2.30	2.42	2.43	2.76	3.00	3.36	3.68
	69°F (20.5°C)	TC	15.99	19.99	24.93	27.30	29.35	30.31	30.28	31.71	33.46	36.34	35.00	35.52
		Input	3.30	3.71	4.17	4.05	4.22	4.05	3.90	4.01	3.81	3.73	3.22	3.00
		COP	1.42	1.58	1.75	1.98	2.04	2.19	2.27	2.32	2.58	2.85	3.19	3.47
	71.6°F (22°C)	TC	15.82	19.75	24.98	27.37	29.08	29.96	29.96	31.43	33.16	35.88	34.06	34.98
		Input	3.37	3.77	4.08	4.05	4.31	4.12	3.97	4.10	3.89	3.80	3.26	3.05
		COP	1.38	1.54	1.79	1.98	1.98	2.13	2.21	2.25	2.50	2.77	3.06	3.36

LEGEND

DB - Dry Bulb
 WB - Wet Bulb
 TC - Total Net Capacity (1000 Btu/hour)
 Input - Total Power (kW)
 COP - W/W

COOLING PERFORMANCE DATA - CONSOLE

MODEL	COOLING			OUTDOOR CONDITIONS (DB)											
	Indoor Conditions DB			-13°F (-25°C)	-4°F (-20°C)	0°F (-17°C)	5°F (-15°C)	17°F (-8°C)	47°F (8°C)	77°F (25°C)	86°F (30°C)	95°F (35°C)	104°F (40°C)	113°F (45°C)	122°F (50°C)
	DB	WB													
12 (208-230V)	69.8°F (21°C)	59°F (15°C)	TC	12.33	11.85	12.26	12.78	12.47	11.04	11.17	12.16	11.11	10.57	8.30	7.21
			SC	8.63	8.04	8.28	8.51	8.38	7.65	7.69	8.14	7.48	7.32	6.25	5.61
			Input	0.60	0.60	0.56	0.86	0.86	0.55	0.80	1.14	1.28	1.30	1.00	1.02
	75.2°F (24°C)	62.6°F (17°C)	TC	13.92	14.11	13.01	13.43	13.30	12.38	11.94	13.06	12.54	11.52	8.67	7.80
			SC	9.75	9.24	8.75	8.87	8.87	8.45	8.16	8.73	8.54	7.94	6.68	6.15
			Input	0.63	0.82	0.58	0.93	0.92	0.72	0.80	1.15	1.35	1.32	1.01	1.03
	80.6°F (27°C)	66.2°F (19°C)	TC	15.01	14.73	14.53	14.06	13.81	12.70	12.82	13.97	13.52	11.91	8.93	8.43
			SC	10.51	9.59	9.51	9.18	9.18	8.71	8.65	9.24	9.06	8.16	6.97	6.63
			Input	0.64	0.87	0.95	0.99	0.88	0.73	0.80	1.16	1.37	1.33	1.01	1.04
	89.6°F (32°C)	73.4°F (23°C)	TC	16.61	15.46	15.35	15.56	14.59	14.25	16.92	15.81	14.96	13.32	9.61	9.09
			SC	11.62	9.42	9.53	9.48	9.18	9.13	10.04	9.74	9.30	8.56	7.16	6.90
			Input	0.65	1.00	1.06	0.97	0.88	1.10	1.15	1.18	1.39	1.36	1.02	1.05
18 (208-230V)	69.8°F (21°C)	59°F (15°C)	TC	19.45	17.69	20.93	19.11	21.35	16.05	17.43	16.68	17.52	13.55	12.01	9.86
			SC	13.62	13.34	15.21	13.97	12.30	11.87	12.59	12.15	12.59	11.45	10.70	9.74
			Input	0.88	0.77	1.12	0.81	1.47	1.04	1.28	1.47	1.87	1.51	1.48	1.55
	75.2°F (24°C)	62.6°F (17°C)	TC	21.20	22.14	21.99	23.25	21.44	16.97	17.29	17.20	19.10	14.19	12.59	10.90
			SC	16.96	15.65	15.56	16.15	15.37	13.30	13.44	13.79	14.27	12.21	11.46	10.76
			Input	0.92	1.19	1.30	1.56	1.59	1.09	1.10	1.49	1.95	1.53	1.49	1.56
	80.6°F (27°C)	66.2°F (19°C)	TC	22.62	23.11	22.64	24.02	22.72	18.42	20.12	19.33	20.38	15.16	13.56	11.53
			SC	18.09	16.29	16.00	16.69	16.28	14.38	14.90	14.50	15.11	13.10	12.28	11.52
			Input	0.93	1.26	1.40	1.66	1.71	1.14	1.30	1.49	1.98	1.54	1.52	1.57
	89.6°F (32°C)	73.4°F (23°C)	TC	25.08	24.66	19.07	25.14	25.27	22.70	24.57	21.85	22.60	17.24	14.59	13.24
			SC	17.56	16.36	13.94	16.62	16.71	15.82	16.19	15.16	15.63	13.93	13.21	12.62
			Input	0.95	1.37	0.75	1.89	1.98	1.58	1.56	1.51	2.03	1.56	1.58	1.60
24 (208-230V)	69.8°F (21°C)	59°F (15°C)	TC	28.91	24.79	25.00	24.78	24.67	24.17	22.98	26.39	26.05	25.25	15.41	12.35
			SC	20.24	18.38	18.56	18.40	18.21	18.13	17.58	19.41	19.21	18.83	13.77	12.04
			Input	1.31	1.56	1.57	1.44	1.33	1.06	1.49	2.33	2.78	3.06	2.03	1.65
	75.2°F (24°C)	62.6°F (17°C)	TC	30.87	26.29	26.60	26.21	26.03	24.83	24.48	29.54	27.81	26.80	16.53	13.07
			SC	21.61	19.61	19.72	19.45	19.23	18.81	18.77	21.24	20.47	20.00	14.64	12.73
			Input	1.33	1.61	1.63	1.47	1.35	1.06	1.48	2.59	2.83	3.10	2.05	1.66
	80.6°F (27°C)	66.2°F (19°C)	TC	32.35	27.87	27.90	27.74	27.29	25.44	26.36	30.74	29.14	28.06	17.00	13.67
			SC	22.64	20.59	20.67	20.48	20.47	19.41	20.02	22.05	21.24	20.88	15.31	13.34
			Input	1.34	1.68	1.61	1.51	1.39	1.06	1.49	2.52	2.85	3.13	2.06	1.67
	89.6°F (32°C)	73.4°F (23°C)	TC	35.52	31.88	30.24	30.78	30.05	26.20	37.03	33.82	32.00	31.19	18.82	15.39
			SC	24.87	21.68	20.90	21.07	21.03	19.23	23.71	22.49	21.97	21.58	16.19	14.43
			Input	1.37	1.83	1.60	1.67	1.43	1.05	2.44	2.42	2.92	3.22	2.09	1.68

LEGEND

- DB - Dry Bulb
- WB - Wet Bulb
- TC - Total Net Capacity (1000 Btu/hour)
- SC - Sensible Capacity (1000 Btu/hour)
- Input - Total Power (kW)

HEATING PERFORMANCE DATA - CONSOLE

MODEL	HEATING		OUTDOOR CONDITIONS (DB)											
	Indoor Conditions DB		-22°F (-30°C)	-13°F (-25°C)	-4°F (-20°C)	0°F (-17°C)	5°F (-15°C)	17°F (-8°C)	19.4°F (-7°C)	24.8°F (-4°C)	32°F (0°C)	39.2°F (4°C)	44.6°F (7°C)	53.6°F (12°C)
12 (208-230V)	59°F (15°C)	TC	11.99	8.82	10.45	11.63	11.64	14.36	14.72	14.86	15.03	16.14	14.88	15.89
		Input	2.64	1.80	1.91	1.98	1.91	2.16	2.20	2.04	1.80	1.93	1.50	1.48
		COP	1.33	1.43	1.60	1.72	1.79	1.95	1.96	2.14	2.45	2.45	2.91	3.14
	64.4°F (18°C)	TC	12.12	8.69	9.41	10.48	12.32	14.09	14.39	14.49	14.84	15.76	14.43	14.95
		Input	2.73	1.83	1.83	1.90	2.05	2.18	2.22	2.10	1.85	1.97	1.51	1.47
		COP	1.30	1.39	1.51	1.62	1.76	1.89	1.90	2.03	2.35	2.34	2.80	2.98
	69°F (20.5°C)	TC	8.31	8.52	10.68	11.29	12.07	13.74	14.04	14.16	14.23	14.77	14.15	14.51
		Input	2.71	1.86	1.90	2.04	2.09	2.20	2.23	2.13	1.90	1.99	1.55	1.52
		COP	1.13	1.34	1.65	1.62	1.69	1.83	1.85	1.95	2.19	2.18	2.68	2.80
	71.6°F (22°C)	TC	11.19	8.80	10.05	11.14	11.92	13.40	13.89	9.06	14.21	14.19	14.04	14.36
		Input	2.49	1.85	1.98	2.03	2.19	2.21	2.26	1.65	1.94	1.84	1.59	1.55
		COP	1.32	1.40	1.49	1.61	1.60	1.77	1.81	1.61	2.15	2.26	2.58	2.72
18 (208-230V)	59°F (15°C)	TC	12.08	15.90	17.65	19.03	18.71	23.05	23.51	20.27	21.41	24.08	22.34	23.55
		Input	2.78	3.37	3.35	3.38	3.14	3.53	3.50	28.27	2.42	2.68	2.15	2.09
		COP	1.25	1.38	1.51	1.65	1.75	1.91	1.97	2.10	2.59	2.64	3.05	3.31
	64.4°F (18°C)	TC	12.49	15.75	18.10	18.08	18.27	22.84	22.78	23.32	20.88	23.12	21.65	23.05
		Input	2.98	3.48	3.68	3.22	3.03	3.67	3.58	3.41	2.49	2.73	2.19	3.13
		COP	1.23	1.33	1.44	1.65	1.77	1.82	1.87	2.01	2.45	2.49	2.90	3.31
	69°F (20.5°C)	TC	12.37	15.67	16.76	15.49	17.73	22.47	22.76	22.60	20.43	22.67	21.18	22.59
		Input	3.04	3.57	3.29	3.17	3.10	3.77	3.74	3.47	2.57	2.79	2.27	2.23
		COP	1.19	1.29	1.49	1.56	1.68	1.75	1.78	1.91	2.33	2.39	2.74	2.97
	71.6°F (22°C)	TC	12.34	15.51	15.68	16.86	18.15	21.65	20.88	21.79	20.49	22.36	20.89	22.32
		Input	3.11	3.62	3.30	3.19	3.41	3.71	3.16	3.45	2.61	2.83	2.32	2.27
		COP	1.16	1.25	1.39	1.55	1.56	1.71	1.94	1.85	2.30	2.31	2.64	2.88
24 (208-230V)	59°F (15°C)	TC	15.10	19.34	24.62	27.79	25.12	30.58	27.62	30.29	32.48	36.69	34.90	35.41
		Input	10.72	12.21	3.90	4.20	4.07	4.15	3.94	3.63	3.57	3.91	3.31	3.07
		COP	1.41	1.58	1.85	1.94	1.81	2.16	2.25	2.45	2.67	2.74	3.09	3.38
	64.4°F (18°C)	TC	14.60	18.97	22.23	27.18	24.45	30.17	29.48	29.66	31.80	35.99	34.04	34.13
		Input	11.22	12.54	0.39	4.36	4.23	4.33	4.16	3.79	3.70	4.07	3.44	3.17
		COP	1.30	1.51	1.68	1.83	1.69	2.04	2.08	2.29	2.52	2.59	2.90	3.16
	69°F (20.5°C)	TC	14.18	18.54	23.71	25.20	23.88	27.97	28.94	29.13	31.21	35.40	32.83	33.47
		Input	11.63	13.03	4.15	4.20	4.37	4.16	4.25	3.93	3.82	4.21	3.50	3.28
		COP	1.22	1.42	1.68	1.76	1.60	1.97	2.00	2.17	2.39	2.46	2.75	2.99
	71.6°F (22°C)	TC	13.96	18.65	23.38	23.57	23.52	27.65	28.73	28.82	30.89	35.63	32.29	32.81
		Input	11.99	13.16	4.22	4.18	4.47	4.26	4.36	4.01	3.91	4.34	3.56	3.33
		COP	1.16	1.42	1.62	1.65	1.54	1.90	1.93	2.11	2.32	2.41	2.66	2.89

LEGEND

DB - Dry Bulb
 WB - Wet Bulb
 TC - Total Net Capacity (1000 Btu/hour)
 Input - Total Power (kW)
 COP - W/W

COOLING PERFORMANCE DATA - AIR HANDLER

MODEL	Cooling		OUTDOOR CONDITIONS (DB)												
	Indoor Conditions		TC	-13°F (-25°C)	-4°F (-20°C)	0°F (-17°C)	5°F (-15°C)	17°F (-8°C)	47°F (8°C)	77°F (25°C)	86°F (30°C)	95°F (35°C)	104°F (40°C)	113°F (45°C)	122°F (50°C)
	DB	WB													
24 (208-230V)	69.8°F (21°C)	59°F (15°C)	TC	23.35	22.96	19.92	19.69	23.95	25.69	16.54	22.26	21.78	21.03	16.91	11.01
			SC	18.82	18.50	15.86	15.69	19.09	20.49	14.53	17.85	17.56	17.40	13.99	10.87
			Input	0.92	1.02	1.10	1.14	1.18	1.33	1.15	2.47	2.86	2.54	2.08	1.72
	75.2°F (24°C)	62.6°F (17°C)	TC	27.70	27.30	24.27	24.04	28.30	30.04	20.89	26.61	26.13	25.38	21.26	15.35
			SC	22.33	22.01	19.56	19.38	22.81	24.21	16.84	21.45	21.07	20.46	17.14	12.38
			Input	1.00	1.09	1.18	1.21	1.26	1.40	1.22	2.55	2.93	2.62	2.16	1.79
	80.6°F (27°C)	66.2°F (19°C)	TC	30.28	29.88	26.85	26.62	30.88	32.62	23.47	29.19	28.71	27.96	23.84	17.93
			SC	24.40	24.09	21.64	21.46	24.89	26.29	18.92	23.53	23.14	22.53	19.22	14.46
			Input	1.04	1.14	1.23	1.26	1.30	1.45	1.27	2.59	2.98	2.67	2.20	1.84
	89.6°F (32°C)	73.4°F (23°C)	TC	34.29	33.90	30.86	30.64	34.89	36.63	27.49	33.21	32.73	31.97	27.86	21.95
			SC	27.64	27.33	24.88	24.69	28.13	29.53	22.16	26.77	26.38	25.77	22.45	17.69
			Input	1.11	1.21	1.30	1.33	1.38	1.52	1.34	2.66	3.05	2.74	2.28	1.91

LEGEND

DB - Dry Bulb
 WB - Wet Bulb
 TC - Total Net Capacity (1000 Btu/hour)
 SC - Sensible Capacity (1000 Btu/hour)
 Input - Total Power (kW)

HEATING PERFORMANCE DATA - AIR HANDLER

MODEL	HEATING		OUTDOOR CONDITIONS (DB)											
	Indoor Conditions DB		-22°F (-30°C)	-13°F (-25°C)	-4°F (-20°C)	0°F (-17°C)	5°F (-15°C)	17°F (-8°C)	19.4°F (-7°C)	24.8°F (-4°C)	32°F (0°C)	39.2°F (4°C)	44.6°F (7°C)	53.6°F (12°C)
24 (208-230V)	59°F (15°C)	TC	16.20	20.25	22.93	24.82	26.97	29.70	29.67	31.16	34.95	36.23	37.15	36.41
		Input	3.09	3.32	3.54	3.69	3.77	3.85	3.78	3.80	3.25	3.29	3.14	2.42
		COP	1.53	1.79	1.90	1.97	2.10	2.26	2.30	2.40	3.16	3.23	3.46	4.41
	64.4°F (18°C)	TC	15.75	19.69	22.30	24.13	26.23	28.88	28.85	30.30	33.99	35.24	36.13	35.41
		Input	3.20	3.43	3.66	3.82	3.89	3.98	3.90	3.93	3.35	3.40	3.25	2.50
		COP	1.44	1.68	1.78	1.85	1.97	2.13	2.17	2.26	2.97	3.04	3.26	4.15
	69°F (20.5°C)	TC	15.60	19.32	21.88	23.68	25.74	28.34	28.31	29.73	33.35	34.57	35.45	34.74
		Input	3.30	3.54	3.78	3.94	4.02	4.11	4.03	4.05	3.46	3.51	3.35	2.58
		COP	1.39	1.60	1.70	1.76	1.88	2.02	2.06	2.15	2.82	2.89	3.10	3.95
	71.6°F (22°C)	TC	14.86	18.58	21.03	22.77	24.75	27.25	27.22	28.59	32.07	33.24	34.08	33.41
		Input	3.40	3.65	3.89	4.06	4.14	4.23	4.15	4.18	3.57	3.62	3.45	2.66
		COP	1.28	1.49	1.58	1.64	1.75	1.89	1.92	2.00	2.63	2.69	2.90	3.68

LEGEND

DB - Dry Bulb
 WB - Wet Bulb
 TC - Total Net Capacity (1000 Btu/hour)
 Input - Total Power (kW)
 COP - W/W

APPLICATION DATA

Unit Selection

Select equipment that either matches or supports slightly more than the anticipated peak load. This provides better humidity control, fewer unit cycles, and less part-load operation. For units used in spaces with high sensible loads, base equipment selection on unit sensible load, not on total anticipated load. Adjust for anticipated room wet bulb temperature to avoid undersizing the equipment.

Unit Mounting (Outdoor)

Refer to the unit's installation instructions for further details.

Unit leveling - For reliable operation, units should be level in all planes.

Clearance - Minimum clearance (see Fig. 6 — on page 9) must be provided for airflow. The condensing units are designed for free-flow application. Air inlets and outlets should not be restricted.

Unit location - A location which is convenient to installation and not exposed to strong winds. A location that can bear the weight of the outdoor unit and where the outdoor unit can be mounted in a level position.

Do not install the indoor or outdoor units in a location with special environmental conditions. For those applications, contact your sales representative.

System Operating Conditions

OPERATING RANGE MIN / MAX ° F (° C)		
	COOLING	HEATING
Outdoor DB (sizes 12 115V)	- 13 / 122 (- 25 / 50)	- 13 / 86 (- 25 / 30)
Outdoor DB (sizes 9 - 24 208/230V)	- 13 / 122 (- 25 / 50)	- 22 / 86 (- 30 / 30)
Outdoor DB (sizes 30 & 36)	- 13 / 122 (- 25 / 50)	- 13 / 86 (- 25 / 30)

NOTE: Reference the product installation instructions for more information.

Cut In/Out Temperatures

CUT IN/OUT TEMPERATURES° F (° C)									
		STANDBY MODE				RUNNING MODE			
		COOLING		HEATING		COOLING		HEATING	
		Cut In	Cut Out	Cut In	Cut Out	Cut In	Cut Out	Cut In	Cut Out
12K	(115V)	-7.6 (-22)	-13 (-25)	-7.6 (-22)	-13 (-25)	-7.6 (-22)	-13 (-25)	-7.6 (-22)	-13 (-25)
9K	(208/230V)	-25.6 (-32)	- 31(-35)	-25.6 (-32)	-31(-35)	-25.6 (-32)	-40 (-40)	-25.6 (-32)	-40 (-40)
12K	(208/230V)	-25.6 (-32)	-31 (-35)	-25.6 (-32)	-31(-35)	-25.6 (-32)	-40 (-40)	-25.6 (-32)	-40 (-40)
18K	(208/230V)	-25.6 (-32)	-31 (-35)	-25.6 (-32)	-31(-35)	-25.6 (-32)	-40 (-40)	-25.6 (-32)	-40 (-40)
24K	(208/230V)	-25.6 (-32)	-31 (-35)	-25.6 (-32)	-31(-35)	-25.6 (-32)	-40 (-40)	-25.6 (-32)	-40 (-40)
30K	(208/230V)	-7.6 (-22)	-13 (-25)	-7.6 (-22)	-13 (-25)	-7.6 (-22)	-13 (-25)	-7.6 (-22)	-13 (-25)
36K	(208/230V)	-7.6 (-22)	-13 (-25)	-7.6 (-22)	-13 (-25)	-7.6 (-22)	-13 (-25)	-7.6 (-22)	-13 (-25)

Metering Devices

The outdoor unit has an expansion valve to manage the refrigerant flow of the connected fan coil.

Drain Connections

Install drains to meet the local sanitation codes.

Refrigerant Lines

General refrigerant line sizing:

1. The outdoor units are shipped with a full charge of R410A refrigerant. All charges, line sizing, and capacities are based on runs of 25 ft. (7.6 m). For runs over 25 ft. (7.6 m), review the "Long Line Applications:" on page 25 for the proper charge adjustments.
2. Refrigerant lines should not be buried in the ground. If it is necessary to bury the lines, do not bury more than 36-in (914 mm). Provide a minimum 6-in (152 mm) vertical rise to the service valves to prevent refrigerant migration.
3. Both lines must be insulated. Use a minimum of 1/2-in. (12.7 mm) thick insulation. Closed-cell insulation is recommended in all long-line applications (Review "Long Line Applications:" on page 25 for details).
4. Special consideration should be given to isolating the interconnecting tubing from the building structure. Isolate the tubing so vibration or noise is not transmitted into the structure.

Long Line Applications:

1. No change in the line sizing is required.
2. Add refrigerant per the Additional Charge Table.

ADDITIONAL CHARGE TABLE

UNIT SIZE	TOTAL LINE LENGTH ft (m)		ADDITIONAL CHARGE, oz/ft. ft (m)			
	Min	Max	10 - 25 (3 - 8)	>25 - 82 (8 - 25)	>82 - 98 (25 - 30)	>98 - 164 (30 - 50)
9	10(3)	82(25)	None	0.16		
12						
18		98(30)		0.16		
24						
30		164(50)		0.32		
36					0.32	

WIRING

All wires must be sized per NEC (National Electrical Code) or CEC (Canadian Electrical Code) and local codes. Use Electrical Data table MCA (minimum circuit amps) and MOCP (maximum over current protection) to correctly size the wires and the disconnect fuse or breakers respectively.

Recommended Connection Method for Power and Communication Wiring:

The main power is supplied to the outdoor unit. The field supplied 14/3 stranded wire with ground with a 600 volt insulation rating, power/communication wiring from the outdoor unit to indoor unit consists of four (4) wires and provides the power for the indoor unit. Two wires are line voltage AC power, one is communication wiring (S) and the other is a ground wire. Wiring between indoor and outdoor unit is polarity sensitive. The use of BX wire is NOT recommended.

If installed in a high Electromagnetic field (EMF) area and communication issues exist, a 14/2 stranded shielded wire can be used to replace L2/N and (S) between outdoor unit and indoor unit landing the shield onto ground in the outdoor unit only.

CAUTION

EQUIPMENT DAMAGE HAZARD
 Failure to follow this caution may result in equipment damage or improper operation.
 Wires should be sized based on NEC and local codes.
 Use copper conductors only with a 600 volt insulation rating wire.

CAUTION

EQUIPMENT DAMAGE HAZARD
 Failure to follow this caution may result in equipment damage or improper operation.
 Be sure to comply with local codes while running wire from the indoor unit to the outdoor unit.
 Every wire must be connected firmly. Loose wiring may cause the terminal to overheat or result in unit malfunction. A fire hazard may also exist.
 Ensure all wiring is tightly connected.
 No wire should touch the refrigerant tubing, compressor or any moving parts.
 Disconnecting means must be provided and shall be located within sight and readily accessible from the air conditioner.
 Connecting cable with conduit shall be routed through the hole in the conduit panel.

AIR FLOW DATA

SYSTEMS	12K (115V)	9K (208/230V)	12K (208/230V)	18K (208/230V)	23K (208/230V)	30K (208/230V)	36K (208/230V)
Outdoor (CFM)	1177	1177	1177	1824	2355	2119	2119

Sound Pressure

Systems		12K (115V)	9K (208/230V)	12K (208/230V)	18K (208/230V)	23K (208/230V)	30K (208/230V)	36K (208/230V)
Outdoor Sound Pressure Level	dB(A)	54.7	56.6	54.6	58.9	61	60	60
Outdoor Sound Power Level	dB(A)	62.5	63	63.5	65.5	68	69.5	69.5

Outdoor Unit Sound Pressure Test Conditions

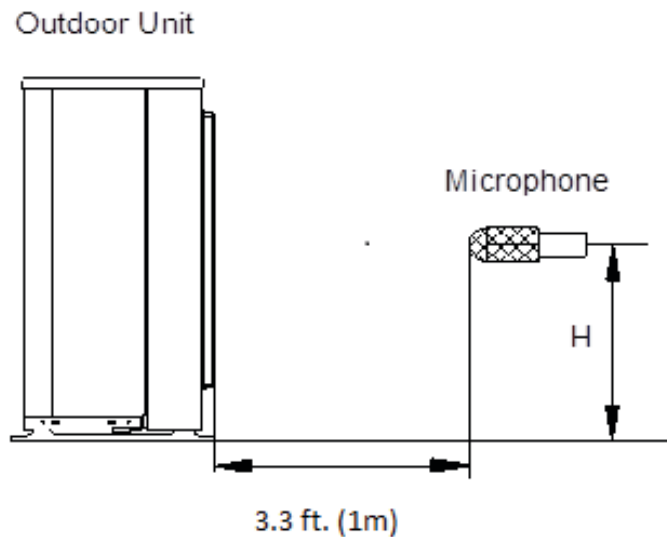

Fig. 8 — Outdoor Unit Sound Pressure Test Conditions

NOTE: H=0.5 x Height of outdoor unit

	INDOOR CONDITION		OUTDOOR CONDITION	
	DB	WB	DB	WB
Cooling	80.6F (27C)	66.2F (19C)	95F (35C)	75.2F (24C)
Heating	68F (20C)	59F (15C)	44.6F (7C)	42.8F (6C)

ELECTRICAL DATA

OUTDOOR UNIT SIZE		12K	9K	12K	18K	23K	30K	36K
Power Supply	Volts- PH- Hz	115 - 1 - 60	208/230 - 1 - 60	208/230 - 1 - 60	208/230 - 1 - 60	208/230 - 1 - 60	208/230 - 1 - 60	208/230 - 1 - 60
	Max - Min*	127 - 104	253 - 187	253 - 187	253 - 187	253 - 187	253 - 187	253 - 187
	MCA	15	9	9	17	20	20	25
	Max Fuse/ CB AMP	20	15	15	25	30	30	35
Compressor	Volts- PH- Hz	115 - 1 - 60	208/230 - 1 - 60	208/230 - 1 - 60	208/230 - 1 - 60	208/230 - 1 - 60	208/230 - 1 - 60	208/230 - 1 - 60
	RLA	10.	5.25	5.65	12.3	14	15	17

*Permissible limits of the voltage range at which the unit operates satisfactorily.

LEGEND

FLA - Full Load Amps
MCA - Minimum Circuit Amps
RLA - Rated Load Amps

WIRING DIAGRAMS

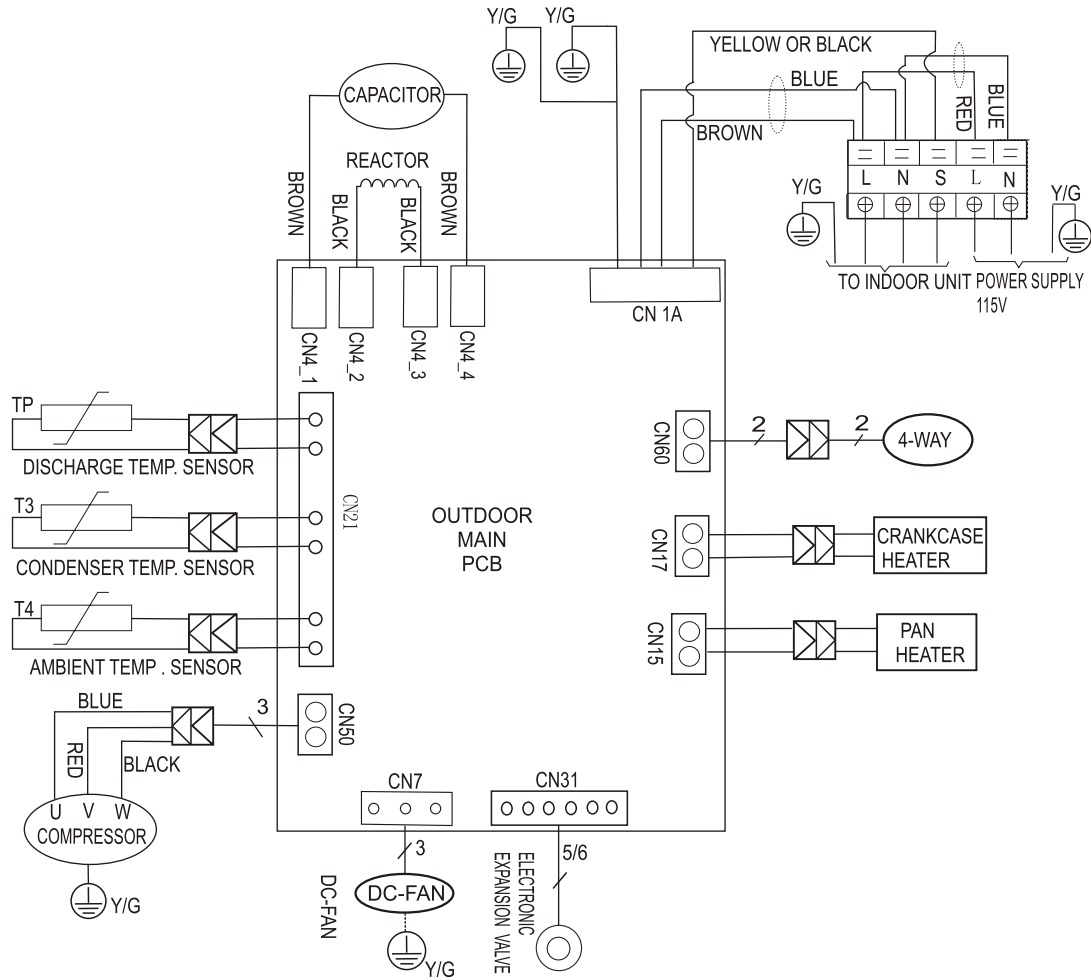

Fig. 9 — Wiring Diagram Sizes 12K (115V)

CODE	PART NAME	CODE	PART NAME
CN1A	INPUT:115V High voltage connector with L/N/Ground/Signal	CN60	Output:115 VAC for 4- way valve control
CN4_1 CN4_2 CN4_3 CN4_4	Output: 115VAC High voltage connector for power factor corrector (PFC)	CN50	Output: PWM for UVW to control Compressor (0 - 320VAC)
CN7	Output: PWM for UVW to control the outdoor fan (0 - 320VAC)	CN21	Input: Temperature acquisition (0 - 5VDC)
CN15	Output:1 15VAC High voltage to control base pan heater	CN31	Connector for electronic expansion valve (0 - 12VDC)
CN17	Output:1 15VAC High voltage to control crankcase heater		

WIRING DIAGRAMS (CONT.)

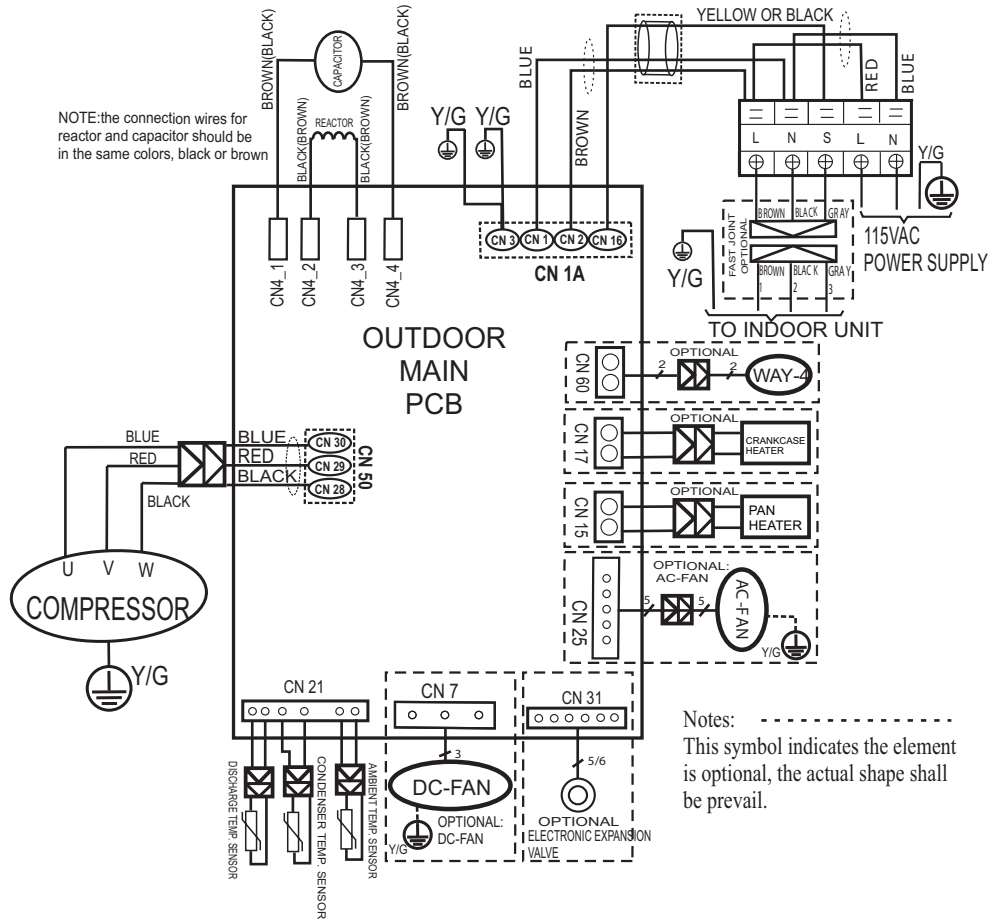

Fig. 10 — Wiring Diagram - Sizes 09K, 12K, 18K (208- 230V)

CODE	PART NAME	CODE	PART NAME
CN2	Output: high voltage signal (to indoor unit)	CN12,CN13	Output: High voltage to reactor
CN7, 8	Input: 220 VAC High voltage (from indoor unit)	UV W	Output: Pulse (0- 320VDC) to compressor
CN60	Output: 220 VAC for 4- way valve control	CN10	Input: Pin1- Pin2 (0- 5V) from discharge temperature sensor
CN16	Output: 220 VAC High voltage to control crankcase heater	CN1	Input: Pin1, Pin3, Pin4, Pin5 (0- 5V) from condenser and outdoor ambient temperature sensors
CN414	Output: Pulse (0- 320VDC) to outdoor fan motor	CN6 - 1	Ground Connector
CN5 (CN4)	Output: 220 VAC High voltage to control base pan heater	CN18	Output: Pin5&6 (12V) to electronic expansion valve

WIRING DIAGRAMS (CONT.)

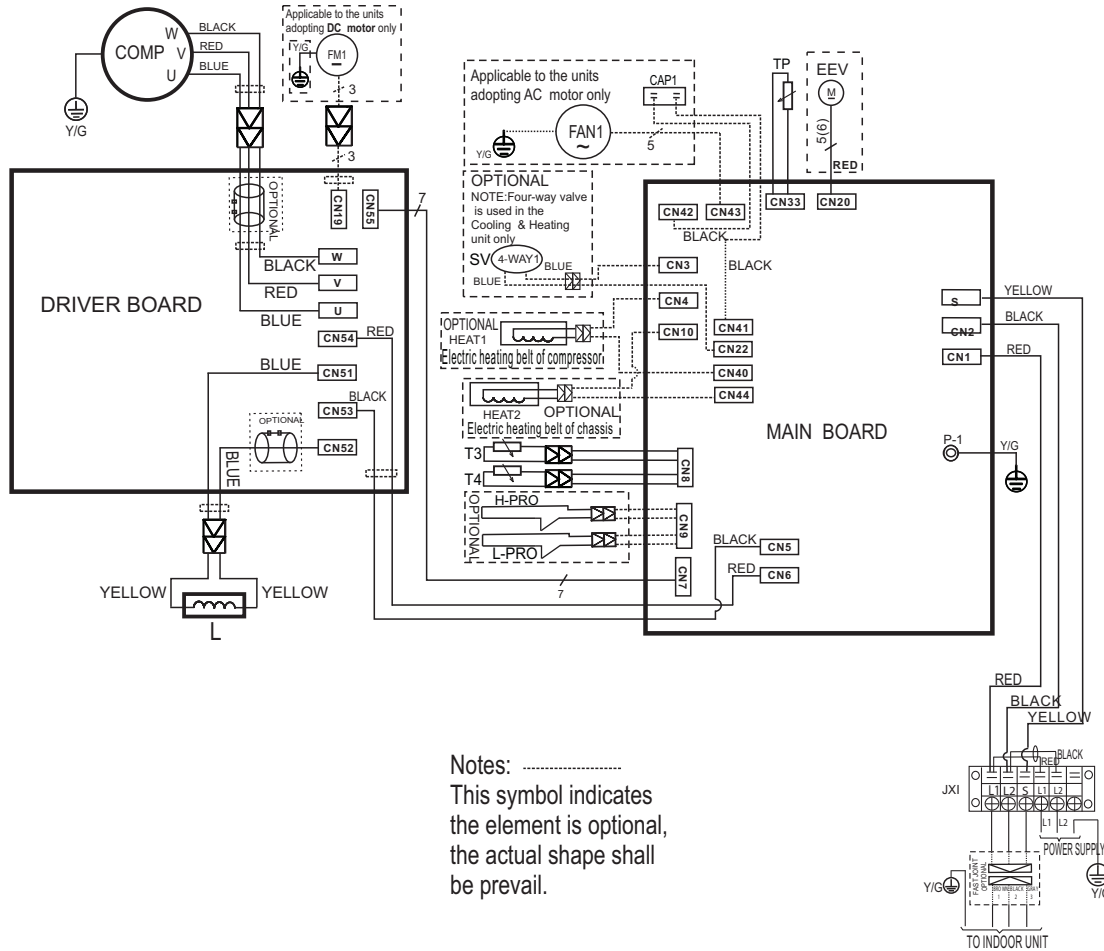

Fig. 11 — Wiring Diagram Sizes 24K- 36K

CODE	PART NAME
COMP	COMPRESSOR
CAP1	FAN MOTOR CAPACITOR
EEV	ELECTRIC EXPANSIVE VALVE
FM1	OUTDOOR DC FAN
FAN1	OUTDOOR AC FAN
HEAT	CRANKCASE HEATING
H-PRO	HIGH PRESSURE SWITCH
L	PFC INDUCTOR
L-PRO	LOW PRESSURE SWITCH
SV	4-WAY VALVE
TP	EXHAUST TEMPERATURE SENSOR
T3	CONDENSER TEMPERATURE SENSOR
T4	OUTDOOR AMBIENT TEMPERATURE SENSOR
TH	HEATSINK TEMPERATURE SENSOR

GUIDE SPECIFICATIONS

HORIZONTAL DISCHARGE DUCTLESS UNITS

Size Range: 3/4 to 3 Ton Nominal Cooling and Heating Capacity
Model Number: DLCSRA

Part 1 - GENERAL

1.01 System Description

1. Outdoor air - cooled split system compressor sections suitable for on- the- ground, rooftop, wall hung or balcony mounting. Units consist of a rotary compressor, an air- cooled coil, propeller-type draw- through outdoor fan, reversing valve (HP), accumulator (HP units), metering device(s), and a control box. Units discharge air horizontally as shown on the contract drawings. Units function as the outdoor component of an air- to- air heat pump system.
2. Units are to be used in a refrigeration circuit matched to ductless heat pump fan coil units.

1.02 Agency Listings

1. Unit construction complies with ANSI/ASHRAE 15, latest revision, and with the NEC.
2. Units are evaluated in accordance with UL standard 1995.
3. Units are listed in the CEC directory.
4. Unit cabinet is capable of withstanding 500- hour salt spray test per Federal Test Standard No. 141 (method 6061).
5. Air- cooled condenser coils are leak tested at 550 psig.

1.03 Delivery, Storage, And Handling

Units are shipped in one piece and are stored and handled per unit manufacturer's recommendations.

1.04 Warranty (For Inclusion By Specifying Engineer)

Part 2 - PRODUCTS

2.01 Equipment

A. General:

Factory assembled, single piece, air-cooled outdoor unit. Contained within the unit enclosure is all the factory wiring, piping, controls, and the compressor.

B. Unit Cabinet:

1. Unit cabinet is constructed of galvanized steel, bonderized and coated with a baked- enamel finish on the inside and outside.
2. Unit access panels is removable with minimal screws and provides full access to the compressor, fan, and control components.
3. The outdoor compartment is isolated and has an acoustic lining to assure quiet operation.

C. Fans:

1. Outdoor fans are the direct drive propeller type, and discharge air horizontally. Fans draw air' through the outdoor coil
2. Outdoor fan motors are totally enclosed, single phase motors with class E insulation and permanently lubricated ball bearings. Motor shall be protected by internal thermal overload protection.
3. The shaft has inherent corrosion resistance.
4. Fan blades are non-metallic and statically and dynamically balanced
5. Outdoor fan openings are equipped with a PVC metal/ mesh coated protection grille over the fan.

D. Compressor:

1. Compressor is the fully hermetic rotary type.
2. Compressor is equipped with an oil system, operating oil charge, and a motor.
3. Motor is NEMA rated class E, suitable for operation in a refrigerant atmosphere.
4. Compressor assembly is installed on rubber vibration isolators.

E. Outdoor Coil:

The coil is constructed of aluminum hydrophilic pre- coated fins mechanically bonded to seamless copper tubes, which are cleaned, dehydrated, and sealed.

F. Refrigeration Components:

Refrigerant circuit components include a brass external liquid line service valve with service gage port connections, a suction line service valve with a service gage connection port, service gage port connections on compressor suction and discharge lines with Schrader type fittings with brass caps, accumulator, reversing valve.

G. Controls and Safeties:

Operating controls and safeties are factory selected, assembled, and tested. The minimum control functions include the following:

1. Controls:
 - a. A time delay control sequence is provided standard through the fan coil board
 - b. Automatic outdoor fan motor protection.
2. Safeties:
 - a. System diagnostics
 - b. Compressor motor current and temperature overload protection
 - c. Outdoor fan failure protection.

H. Electric Requirements:

1. Unit operates on single- phase, 60 Hz power at 115V for unit size 12 and 208/230V for unit sizes 09, 12, 18, 24, 30 and 36, as specified.
2. Unit electrical power has a single point connection.
3. Unit Control voltage to the indoor fan coil is 0-15V DC.
4. All power and control wiring must be installed per NEC and all local electrical codes.
5. The unit has high and low voltage terminal block connections.