

# FORCE™ OIL

---

## Residential

- High Efficiency
- Oil-Fired, 3-Pass
- Water Boiler
- Natural Draft or Direct Vent (140-E and 182-E)

**Models:**

- FORCEOL84-E
- FORCEOL115-E
- FORCEOL140-E
- FORCEOL182-E

<u>Manual Contents</u>	<u>Page</u>
General Information . . . . .	5
Pre-installation . . . . .	7
Packaged Boiler Assy. - Trim & Controls . . . . .	9
Water Boiler Piping . . . . .	17
Indirect Water Heater Piping . . . . .	21
Natural Draft Venting (Chimney) . . . . .	22
Direct Venting/Air Intake Piping . . . . .	26
Electrical . . . . .	33
Oil Piping . . . . .	37
System Start-up . . . . .	39
Operating . . . . .	46
Service and Maintenance . . . . .	48
Boiler Cleaning . . . . .	50
Troubleshooting . . . . .	53
Service Parts . . . . .	55
Burner Specifications . . . . .	66
Appendix A Aftermarket LWCO . . . . .	66



As an ENERGY STAR® Partner, U.S. Boiler Company has determined that the FORCEOL meet the ENERGY STAR® guidelines for energy efficiency established by the United States Environmental Protection Agency (EPA).

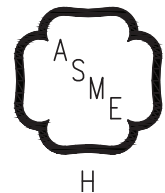

**TO THE INSTALLER:**

Affix these instructions adjacent to boiler.

**TO THE CONSUMER:**

Retain these instructions for future reference.



---

**IMPORTANT INFORMATION - READ CAREFULLY**

---

All boilers must be installed in accordance with National, State and Local Plumbing, Heating and Electrical Codes and the regulations of the serving utilities. These Codes and Regulations may differ from this instruction manual. Authorities having jurisdiction should be consulted before installations are made.

In all cases, reference should be made to the following Standards:

**USA BOILERS**

- A. Current Edition of American National Standard ANSI/NFPA 31, “Installation of Oil Burning Equipment”, for recommended installation practices.
- B. Current Edition of American National Standard ANSI/NFPA 211, “Chimneys, Fire places, Vents, and Solid Fuel Burning Appliances”, For Venting requirements.
- C. Current Edition of American Society of Mechanical Engineers ASME CSD-1, “Controls and Safety Devices for Automatically Fired Boilers”, for assembly and operations of controls and safety devices.
- D. All wiring on boilers installed in the USA shall be made in accordance with the National Electrical Code and/or Local Regulations.

The following terms are used throughout this manual to bring attention to the presence of hazards of various risk levels, or to important information concerning product life.

** DANGER**

Indicates a hazardous situation that, if not avoided, will result in death or serious injury.

** CAUTION**

Indicates a hazardous situation that, if not avoided, could result in minor or moderate injury.

** WARNING**

Indicates a hazardous situation that, if not avoided, could result in death or serious injury.

**NOTICE:** Indicates special instructions on installation, operation, or service which are important but not related to personal injury hazards.

---

**NOTICE:** This boiler has a limited warranty. The warranty for this boiler is valid only if the boiler has been installed, maintained and operated in accordance with these instructions.

Surface rust on cast iron sections may be attributed to the manufacturing process as well as condensation during storage. Surface rust is normal and does not affect the performance or longevity of a boiler.

**⚠ DANGER**

DO NOT store or use gasoline or other flammable vapors or liquids in the vicinity of this or any other appliance.

**⚠ WARNING**

- Improper installation, adjustment, alteration, service or maintenance can cause property damage, personal injury or loss of life. Failure to follow all instructions in the proper order can cause personal injury or death. Read and understand all instructions, including all those contained in component manufacturers manuals which are provided with the appliance before installing, starting-up, operating, maintaining or servicing this appliance. Keep this manual and literature in legible condition and posted near appliance for reference by owner and service technician.
- This boiler requires regular maintenance and service to operate safely. Follow the instructions contained in this manual.
- Installation, maintenance, and service must be performed only by an experienced, skilled and knowledgeable installer or service agency.
- All heating systems should be designed by competent contractors and only persons knowledgeable in the layout and installation of hydronic heating systems should attempt installation of any boiler.
- Installation is NOT complete unless a pressure relief valve is installed into the 3/4" tapping located on supply piping that was installed into boss on top of rear section - See "Packaged Boiler Assy - Trim & Controls" and "Water Boiler Piping" Sections of this manual for details.
- It is the responsibility of the installing contractor to see that all controls are correctly installed and are operating properly when the installation is complete including verifying that the limit sensor is fully installed. Failure to properly install Limit Sensor may result in property damage, personal injury or loss of life due to elevated operating temperatures and/or pressures.
- This boiler is suitable for installation on combustible flooring. DO NOT install boiler on carpeting.
- DO NOT tamper with or alter the boiler or controls.
- Inspect flueways at least once a year - preferably at the start of the heating season. The inside of the combustion chamber, the vent system and boiler flueways should be cleaned if soot or scale has accumulated.

When cleaning this boiler, take precaution to avoid damage to burner swing door insulation. If damaged, or if there is evidence of previous damage, burner swing door insulation must be replaced immediately.

- Oil Burner and Controls must be checked at least once a year or as may be necessitated.
- DO NOT operate unit with jumpered or absent controls or safety devices.
- DO NOT operate unit if any control, switch, component, or device has been subject to water.
- Boiler materials of construction, products of combustion and the fuel contain alumina, silica, heavy metals, carbon monoxide, nitrogen oxides, aldehydes and/or other toxic or harmful substances which can cause death or serious injury and which are known to the state of California to cause cancer, birth defects and other reproductive harm. Always use proper safety clothing, respirators and equipment when servicing or working nearby the appliance.

 **WARNING**

- This boiler contains very hot water under high pressure. DO NOT unscrew any pipe fittings nor attempt to disconnect any components of this boiler without positively assuring the water is cool and has no pressure. Always wear protective clothing and equipment when installing, starting up or servicing this boiler to prevent scald injuries. DO NOT rely on the pressure and temperature gauges to determine the temperature and pressure of the boiler. This boiler contains components which become very hot when the boiler is operating. DO NOT touch any components unless they are cool.
- This boiler must be properly vented. The boiler must be connected to an approved chimney or vent system in good condition. Serious property damage could result if the boiler is connected to a dirty or inadequate chimney or vent system. The chimney must be inspected for any obstructions and cleaned prior to each heating season. A clean and unobstructed chimney flue is necessary to produce the minimum draft required to safely evacuate noxious fumes that could cause personal injury or loss of life. DO NOT operate boiler with the absence of an approved vent system. Evidence of loose debris and or condensate induced stains at the base of the chimney flue, connector or smokepipe joints may be signs of condensing flue gases. Flue gas condensate is corrosive, which requires special consideration and must be addressed immediately. Refer to "Natural Draft Venting (Chimney)" listed in Table of Contents below .
- This boiler needs fresh air for safe operation and must be installed so there are provisions for adequate combustion and ventilation air.
- This boiler is supplied with controls which may cause the boiler to shut down and not re-start without service. If damage due to frozen pipes is a possibility, the heating system should not be left unattended in cold weather; or appropriate safeguards and alarms should be installed on the heating system to prevent damage if the boiler is inoperative.
- This boiler is designed to burn No. 2 fuel oil only. DO NOT use gasoline, crankcase drainings, or any oil containing gasoline. Never burn garbage or paper in this boiler. DO NOT convert to any solid fuel (i.e. wood, coal). DO NOT convert to any gaseous fuel (i.e. natural gas, LP). All flammable debris, rags, paper, wood scraps, etc., should be kept clear of the boiler at all times. Keep the boiler area clean and free of fire hazards.
- All boilers equipped with burner swing door have a potential hazard which, if ignored, can cause severe property damage, personal injury or loss of life. Before opening swing door turn off service switch to boiler to prevent accidental firing of burner outside the combustion chamber. Be sure to tighten swing door fasteners completely when service is completed.

# 1 General Information

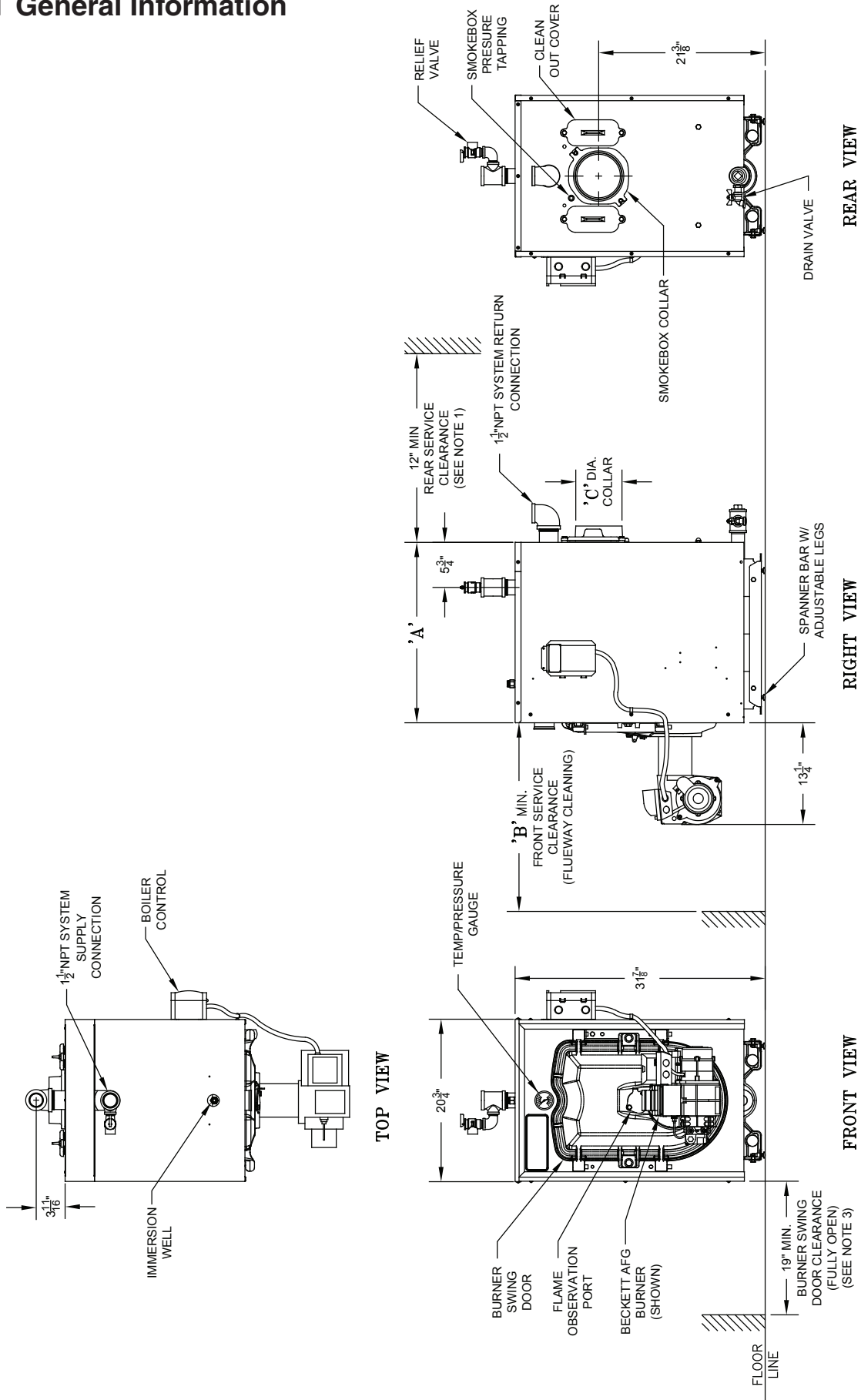

- NOTES:
1. THIS DIMENSION INCREASES AND IS CONTROLLED BY SMOKEPIPE ARRANGEMENT.
  2. DRAIN VALVE AND RELIEF VALVE/FITTINGS SHIPPED LOOSE.
  3. BOILER SHIPPED WITH STANDARD RIGHT HAND HINGE CONFIGURATION, BUT CAN BE CONVERTED TO LEFT HAND HINGE. APPLY CLEARANCE ACCORDINGLY.

Figure 1: FORCE OIL Dimensions

# 1 General Information *(continued)*

**Table 1A: Dimensional Data (See Figure 1)**

Boiler Model	Dimensions See Figure 1			Water Content - Gallons	Heat Transfer Surface Area - Sq. Ft.	Actual Shipping Weight (LB.)
	"A"	"B"	"C"			
FORCEOL084-E/115-E	17"	24"	5"	7.70	13.29	475
FORCEOL140-E	23"	24"	6"	11.08	20.29	567
FORCEOL182E	29"	30"	6"	14.46	27.29	660

**NOTE:** 1. Maximum Working Pressure: Water: 30 PSI Shipped From Factory (Standard),  
50 PSI Optional

**Table 1B: Rating Data**

Boiler Model	Burner Capacity		Minimum Chimney Recommendations			Direct Vent System	
	GPH	MBH	Round In. Dia.	Rectangle In. x In.	Height Ft.	Kit Part Number	Vent Connector Dia. Inch
FORCEOL084-E	0.60	84	6	8 x 8	15	N/A	N/A
FORCEOL115-E	0.80	115	6	8 x 8	15	N/A	N/A
FORCEOL140-E	1.00	140	6	8 x 8	15	106401-01	5
FORCEOL182-E	1.30	182	7	8 X 8	15	106401-01	5

## 2 Pre-Installation

### A. **INSPECT SHIPMENT** carefully for any signs of damage.

1. All equipment is carefully manufactured, inspected and packed. Our responsibility ceases upon delivery of crated boiler to the carrier in good condition.
2. Any claims for damage or shortage in shipment must be filed immediately against the carrier by the consignee. No claims for variances from, or shortage in orders, will be allowed by the manufacturer unless presented within sixty (60) days after receipt of goods.

### B. **LOCATE BOILER** in front of final position before removing crate. See Figure 1.

1. **LOCATE** so that vent pipe connection to chimney will be short and direct.
2. **BOILER IS SUITABLE FOR INSTALLATION ON COMBUSTIBLE FLOOR.** Boiler cannot be installed on carpeting.
3. **FOR BASEMENT INSTALLATION,** provide a solid elevated base, such as concrete, if floor is not level, or if water may be encountered on floor around boiler.
4. **PROVIDE RECOMMENDED SERVICE CLEARANCE,** if applicable, as follows:
  - a. Clearance from Jacket Front Panel -
    - 24" for servicing burner
    - 24" for flueway cleaning (FORCEOL084-E through FORCEOL140-E).

- 30" for flueway cleaning (FORCEOL182-E)
- b. Clearance from Jacket Left Side Panel -
    - 19" for burner swing door, if opened fully with burner mounted, otherwise 1" with burner removed
    - 12" access clearance to service rear of boiler if right side clearance is less than 12"
    - 3" minimum if right side clearance is 12" or larger to access and service rear of boiler.
  - c. Clearance from Jacket Right Side Panel -
    - 3" minimum if left side clearance is 12" or larger to access and service rear of boiler.
  - d. Clearance from Jacket Rear Panel -
    - 12" minimum for rear smokebox cleaning (**NOTE:** This dimension will also be controlled by horizontal to vertical to horizontal smokepipe arrangement - **Chimney Vent** (see Figures 2A and 13).
    - 24" for rear smoke box cleaning and disconnecting vent pipe from boiler adaptor for servicing (if required) - **Direct Vent** (see Figures 2B and 25).

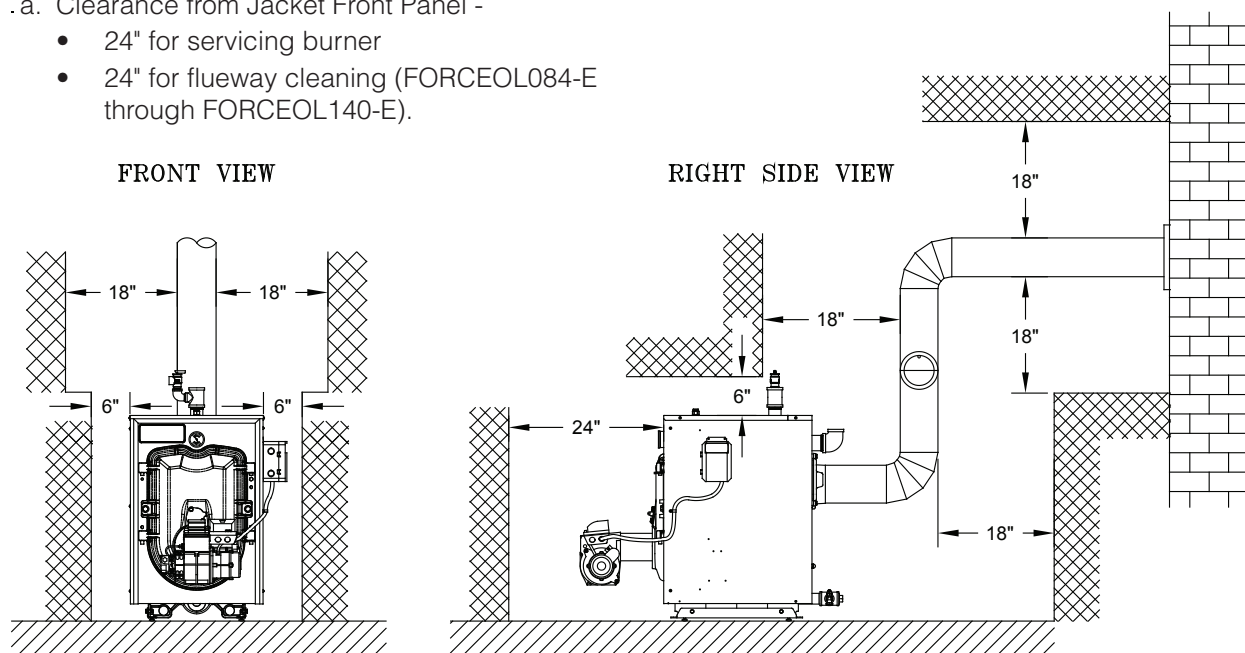

**Figure 2A: Chimney Vent - Minimum Installation Clearances To Combustible Materials (Inches)**

- NOTES:**
1. Listed clearances comply with American National Standard ANSI/NFPA 31, *Standard for the Installation of Oil Burning Equipment*.
  2. FORCE OIL boilers can be installed in rooms with clearances from combustible material as listed above. Listed clearances cannot be reduced for alcove or closet installations.

3. For reduced clearances to combustible material, protection must be provided as described in the above ANSI/NFPA 31 standard.

## 2 Pre-Installation *(continued)*

5. For minimum clearances to combustible materials. See Figures 2A and 2B.

**NOTICE:** Clearance to venting is for single wall vent pipe. If Type L vent is used, clearance may be reduced to the minimum required by the vent pipe manufacturer.

### C. PROVIDE COMBUSTION AND VENTILATION

**AIR.** Local and National Codes may apply and should be referenced.

### D. DIRECT VENT CONFIGURATIONS requires:

1. Beckett NX Burner
2. Direct Vent conversion Kit
3. Double Wall Flex Oil Vent Pipe (FOVP)

### ⚠ WARNING

Adequate combustion and ventilation air must be provided to assure proper combustion and to maintain safe ambient air temperatures. Do not install boiler where gasoline or other flammable vapors or liquids, or sources of hydrocarbons (i.e. bleaches, fabric softeners, etc.) are used or stored.

**Table 2: Direct Vent Configuration Components**

Boiler Model	Beckett NX Oil Burner Part No.	Direct Vent Conversion Kit Part No.	FOVP Carton Part No.
FORCEOL140-E	106109-03	106401-01	100212-02 - 10 ft.
FORCEOL182-E	103369-01		100214-02 - 20 ft.

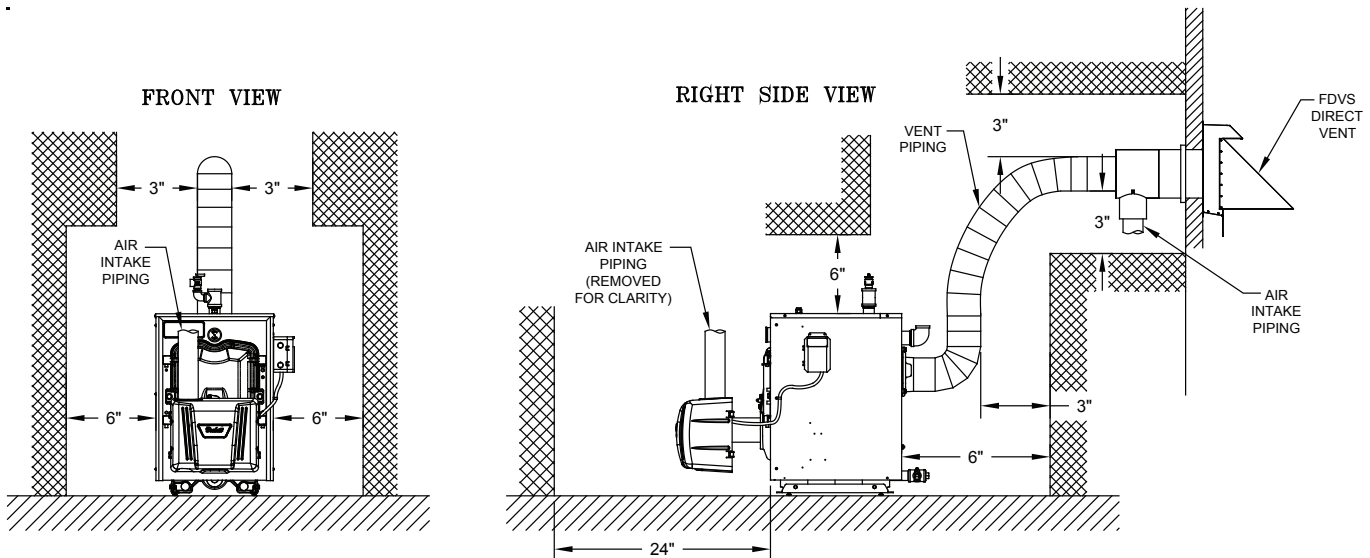

**Figure 2B: Direct Vent - Minimum Installation Clearances To Combustible Materials (Inches)**

- NOTES:**
1. Listed clearances comply with American National Standard ANSI/NFPA 31, *Standard for the Installation of Oil Burning Equipment*.
  2. FORCE OIL boilers can be installed in rooms with clearances from combustible material as listed above. Listed clearances cannot be reduced for alcove or closet installations.
  3. For reduced clearances to combustible material, protection must be provided as described in the above ANSI/NFPA 31 standard.



### 3 Packaged Boiler Assembly - Trim & Controls

#### A. REMOVE CRATE.

1. Remove all fasteners at crate skid.
2. Lift outside container and remove all other inside protective spacers and bracing. Remove miscellaneous parts carton.

#### B. REMOVE BOILER FROM SKID.

1. To reduce the risk of damage to boiler jacket, use the following procedure to remove from skid, see Figure 3:

**Step 1.** Boiler is secured to base with (4) 5/16" cap screws, (2) in front and (2) in rear of shipping skid, see Figure 3. Remove all securing hardware.

**Step 2.** Place wooden block(s) 12" from rear of skid as shown (one piece 4" x 4" x 16" lg. or two pieces of 2" x 4" x 16" lg.)

**Step 3.** Insert 1" Sch. 40 pipe handles through leg hole in front and rear legs. Center end of pipe on wooden blocks as shown in Figure 3.

**NOTE:** Pipe handles should extend a minimum of 48" beyond jacket front panel for best leverage.

**Step 4.** Using the pipe handles, lift boiler until adjustable legs are elevated above the deck boards.

**Step 5.** Remove skid from underneath the boiler.

**Step 6.** Lower pipe handles until front adjustable legs touch floor. If necessary, place wooden blocks under front legs before lowering to provide hand clearance.

**Step 7.** To lower rear of boiler, tilt unit slightly forward by pushing on smokebox collar or lift pipes protruding through rear legs until wooden blocks can be removed (see Figure 3). Slowly allow the weight of the boiler to tilt backward until rear legs rest on floor.

**Step 8.** If wood block was placed under front legs, lift pipe handles, remove wooden block and lower front legs to floor. Remove pipe handles.

#### CAUTION

Do not drop boiler. Do not bump boiler jacket against floor.

#### C. MOVE BOILER TO PERMANENT POSITION by sliding or walking.

#### D. PROCEDURE TO OPEN, CLOSE AND SECURE BURNER SWING DOOR

Throughout this manual you will be instructed to open and close the burner swing door for various reasons. There is a proper and improper method to closing and securing the burner swing door opened for inspection, cleaning or field service.

1. TO OPEN BURNER SWING DOOR (see Figures 4A and 4B).

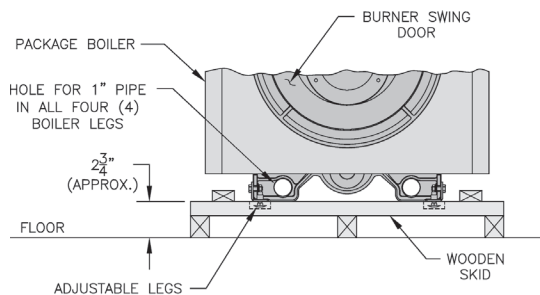

PARTIAL FRONT VIEW

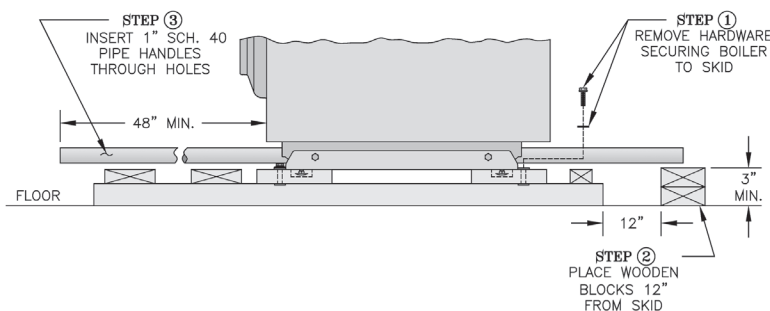

PARTIAL SIDE VIEW NO. 1

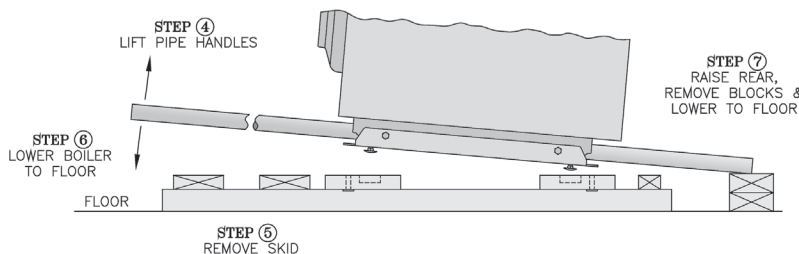

PARTIAL SIDE VIEW NO. 2

Figure 3: Packaged Boiler Removal from Skid

### 3 Packaged Boiler Assembly - Trim & Controls *(continued)*

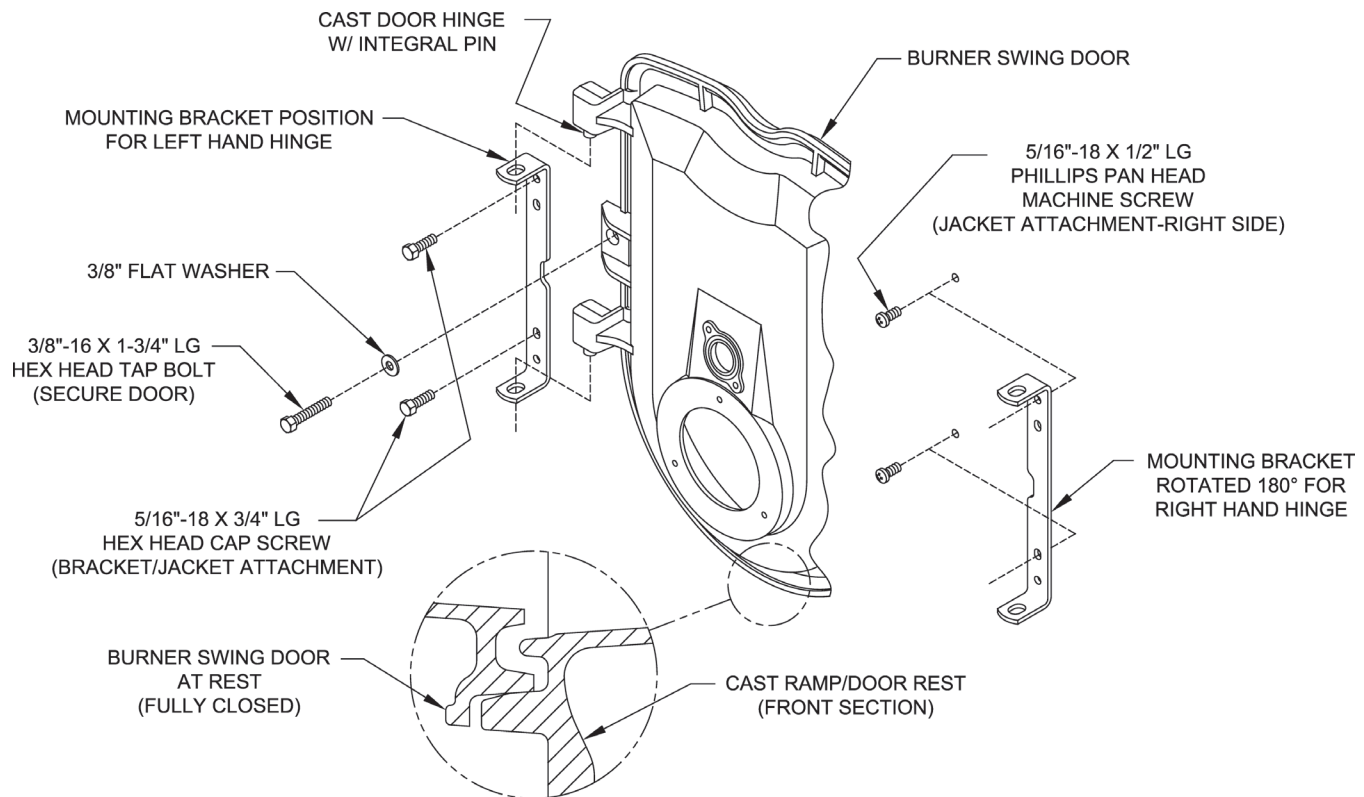

**Figure 4A: Partial Front View - Burner Swing Door Mounted to Boiler - Fully Closed and Secured**

**Step 1.** Loosen but do not remove left side latching hardware (3/8" x 1-3/4" lg. tap bolt).

**Step 2.** Loosen and remove right side latching hardware (3/8" x 1-3/4" lg. tap bolt and washer).

**Step 3.** Remove left side latching hardware (3/8" x 1-3/4" lg. tap bolt and washer).

**Step 4.** Disconnect power from boiler.

**Step 5.** Door can be swung to the fully open position, approximately 90° to 120°, with the burner mounted providing that there is 19" of clearance to the adjacent wall, see Figure 1.

**NOTE:** If reduced clearance prevents the door from opening fully, one of the following can provide full access:

- Burner can be removed to allow full rotation of door.
- Door with burner mounted can be lifted off mounting bracket and set aside during servicing.
- The door mounting hardware is reversible from left side hinge (as shipped) to right side hinge.

To reverse hinge arrangement (see Figure 4A):

- Lift door off mounting bracket and set aside.
- Remove mounting bracket and hardware from left side.
- Remove upper jacket front panel retaining screw (5/16" x 1/2" lg. Phillip Pan head machine screw) from right side of door and re-install in vacated upper mounting bracket tapping. Do not tighten.
- Move lower jacket panel retaining screw from right side to left tapping. Do not tighten.
- Rotate door mounting bracket 180°. Insert 5/16" cap screw through top hole in bracket and install in upper vacated jacket hole on right side of door.
- Install second 5/16" cap through bracket hole into lower vacated tapping on right side.
- Tighten both sets of hardware to secure jacket and mounting bracket.
- Lift door and place integral cast hinge pins on door into slotted mounting bracket holes.

### 3 Packaged Boiler Assembly - Trim & Controls *(continued)*

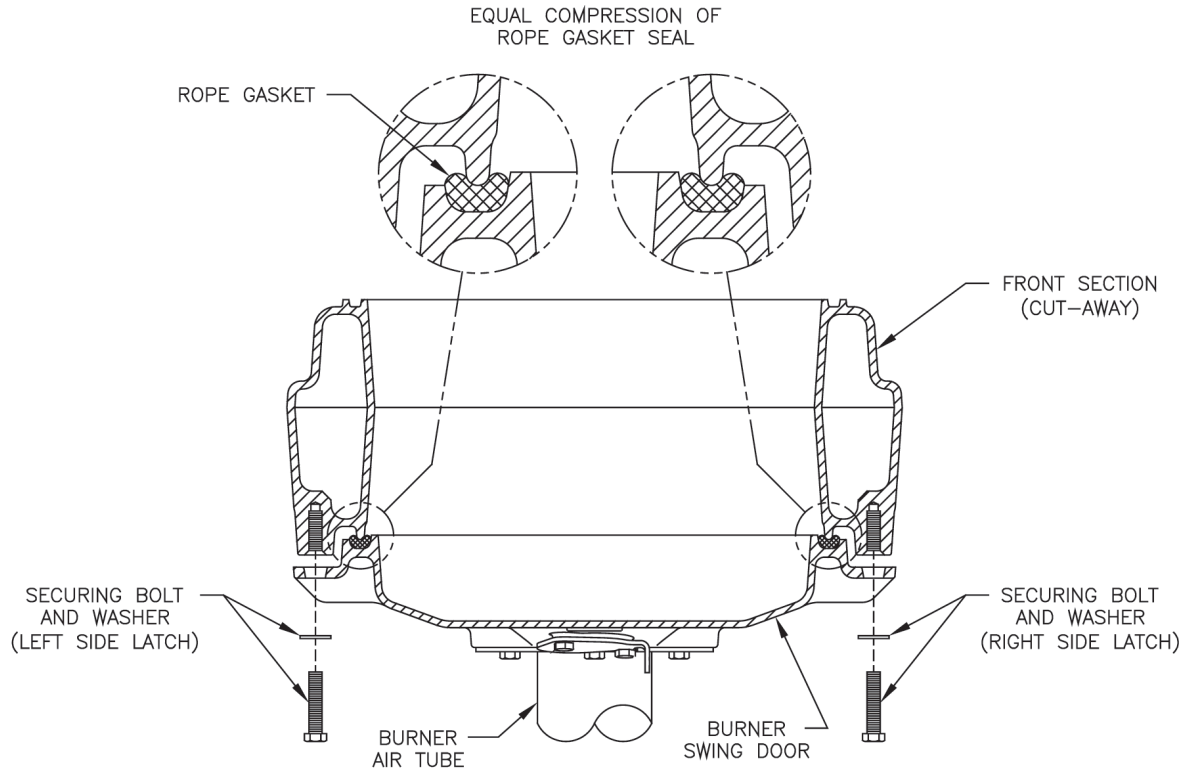

**POSITION 1**  
(PROPERLY CLOSED AND SECURED)

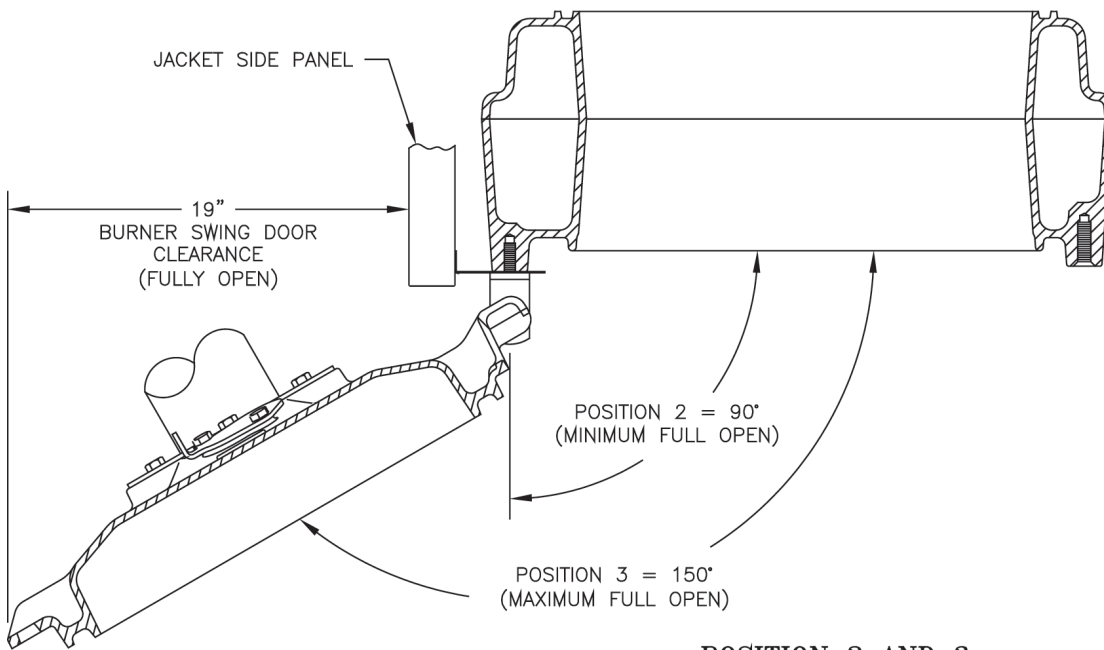

**POSITION 2 AND 3**  
(SWING RADIUS TO FULL OPEN POSITION)

**Figure 4B: Top View - Burner Swing Door Mounted to Cast Iron Block Assembly (Jacket Removed for Clarity)**

### 3 Packaged Boiler Assembly - Trim & Controls *(continued)*

2. Perform routine inspection, service or cleaning as necessary.
3. TO CLOSE BURNER SWING DOOR (see Figures 4A and 4B):

**Step 1.** From the fully open position, rotate Burner Swing Door to the closed position.

**Step 2.** If necessary, place your right hand under the burner air tube to lift upward. Lift the door up unto the built-in cast ramp/door rest (protruding from the bottom of the front section casting - see Figure 4A).

**Step 3.** Use one hand to help hold door in position by lifting up on rear burner housing or applying pressure directly to the door while re-installing the securing hardware with your opposite hand. **Always install right side latching hardware (3/8"-16 x 1-3/4" lg. tap bolt and flat washer) first,** then install left side hinge hardware (3/8"-16 x 1-3/4" lg. tap bolt and flat washer) **second.** Apply additional pressure while hand tightening the hardware as far as possible, then release the pressure.

**NOTICE:** When securing burner swing door make sure door is drawn-in equally on both sides.

**Step 4.** Use a hand wrench to tighten door hardware and **always start with the right**

**side cap screw first.** Use an alternating tightening method from right side tap bolt to left side tap bolt to tighten door equally until sealed without applying excessive torque. **Never** tighten left side flange bolt first or tighten either piece of hardware 100% without using the alternating tightening method described above.

Failure to follow the prescribed procedure could cause thread damage to casting or a leak in the door seal. If left side tap bolt is tightened before right side tap bolt, right side of door can not be drawn-in to provide an air tight seal, as shown in Figure 4C. Applying excessive torque will only cause thread damage.

#### E. INSPECT SWING DOOR INSULATION AND ROPE GASKET.

1. Open burner swing door using procedure previously outlined in Paragraph D of this section.
2. Inspect fiberglass rope located on the swing door. The rope must be evenly distributed around the perimeter of the door groove and cannot bunch or overhang. There must not be a gap where the two ends of the rope meet. Repair or replace if the rope is damaged or if there is a gap between the ends.

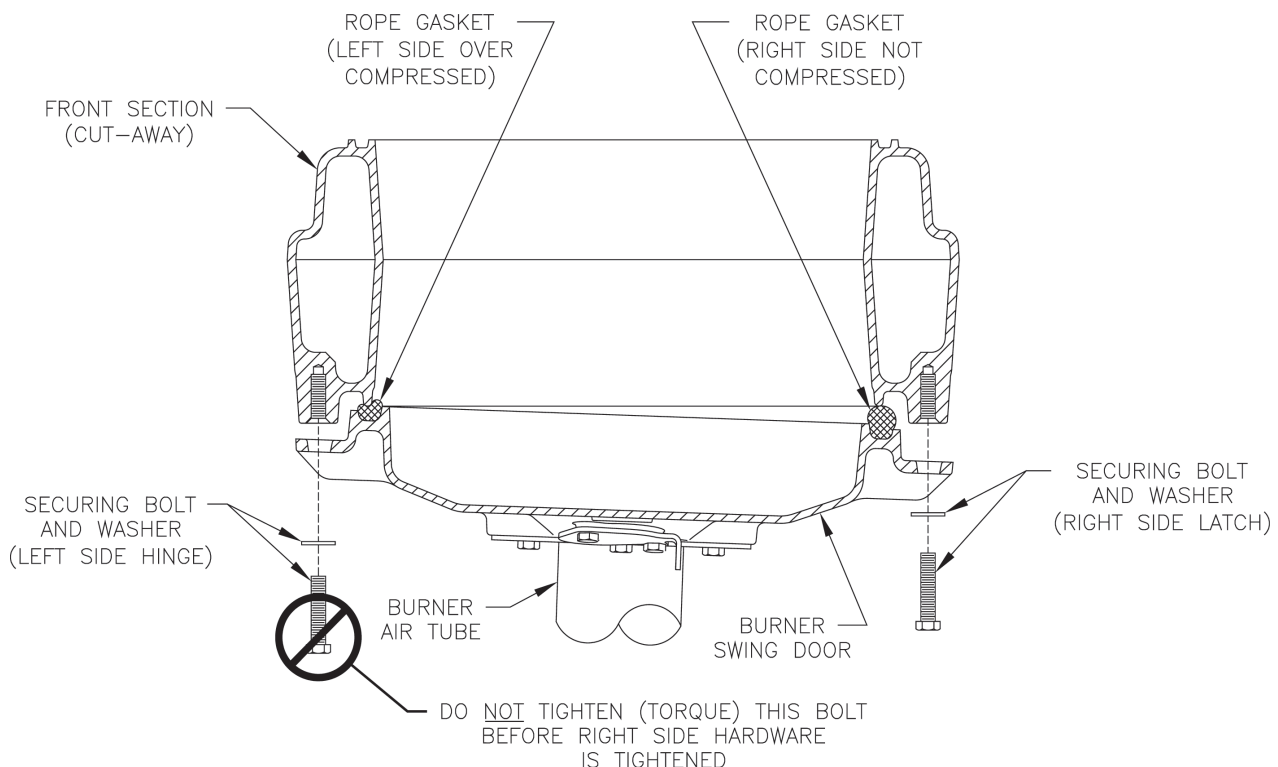

**Figure 4C: Top View - Burner Swing Door Fully Closed but Not Properly Secured or Sealed**

### 3 Packaged Boiler Assembly - Trim & Controls *(continued)*

3. Inspect burner swing door insulation for damage and proper type.

By design, cast bars on front section between the combustion chamber and between the left and right side 2<sup>nd</sup> and 3<sup>rd</sup> pass flueway should make an impression in door insulation to seal the chambers.

If insulation is damaged, it must be replaced.

4. Do not close and secure door at this time, proceed to Field Assembly Details, Paragraph F.

#### F. FIELD ASSEMBLY OF BOILER TRIM AND CONTROLS

Open miscellaneous parts carton and remove contents. Identify the components using the illustrations (see Figure 5) throughout the assembly sequence outlined below as it applies to your installation.

1. Install supply piping and relief valve, refer to Figures 1 and 5.

**Step 1.** Locate the supply piping supplied with boiler. Apply thread sealant to all joints prior to assembly. Thread 1½" NPT x 6" long supply nipple into 1½" NPT tapping on the topside of the rear section. Thread 1½" x 1½" x ¾" NPT tee onto 6" nipple. Tighten all joints until watertight and ¾" NPT connection on tee is positioned to allow clearance for relief valve discharge.

**Step 2.** Locate the relief valve piping supplied with boiler. Apply thread sealant to all joints prior to assembly. Thread the ¾" NPT street elbow onto tee listed above. Install relief valve into street elbow. Tighten all joints until watertight and relief valve is positioned to allow clearance for discharge. Installation of the relief valve must be consistent with ANSI/ASME Boiler and Pressure Vessel Code, Section IV.

#### **⚠ WARNING**

Safety valve discharge piping must be piped near floor to eliminate potential of severe burns. Do not pipe in any area where freezing could occur. Do not install any shut-off valves, plugs or caps.

2. Install Boiler Control  
(Hydrolevel HydroStat 3250 Plus)

**Step 1.** Locate the HydroStat/Harness Assembly. Refer to the 36" Remote Mounting Kit instructions (Included in the 36" Remote Mounting Kit, P/N 105288-01) located in the Misc. Parts Carton. Secure HydroStat 3250 Plus control to the hinge side Side Panel with supplied sheet metal screws as shown in Figure 5.

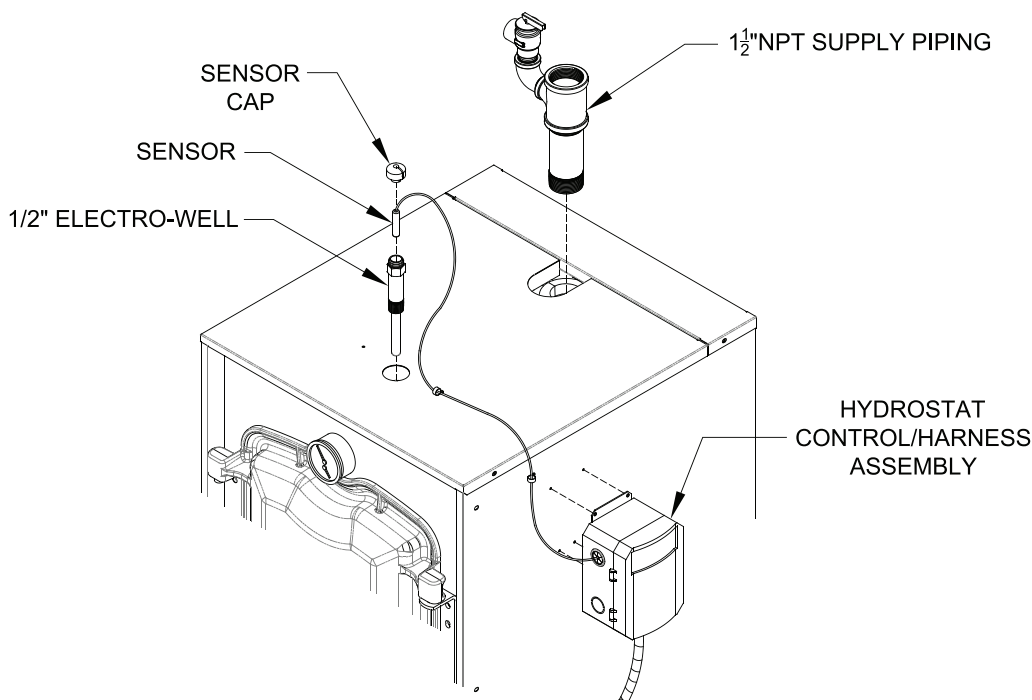
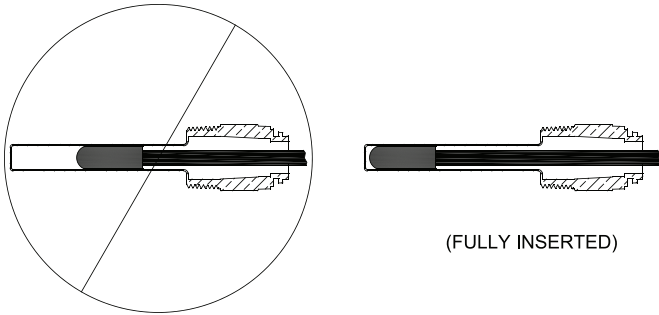

Figure 5: Supply Piping and HydroStat 3250 Plus Control Assembly Details

### 3 Packaged Boiler Assembly - Trim & Controls *(continued)*



INCORRECT                      CORRECT  
**Figure 6: Limit Sensor Insertion**

**Step 2.** Locate (2) 5/8" cable clamps in parts carton. Secure burner wiring harness to front of jacket right side panel with cable clamps and existing jacket screws at top and mid-point.

**Step 3.** Locate the sensor (included in the 36" Remote Mounting Kit). Carefully connect sensor into the HydroStat 3250 Plus circuit board by pressing connector on sensor unit into mating connector on circuit board. Fish the sensor through top knockout; allow adequate slack in sensor cable. Insert sensor into Electro-well located in the front section until it rests against the bottom of the well. Secure sensor to Electro-well with supplied well cap (included in the 36" Remote Mounting Kit).

**Step 4.** Locate (2) 3/16" cable clamps in parts carton. Secure sensor wire to top jacket panel and side jacket panel with cable clamps with self-tapping sheet-metal screws (included) as shown in Figure 5.

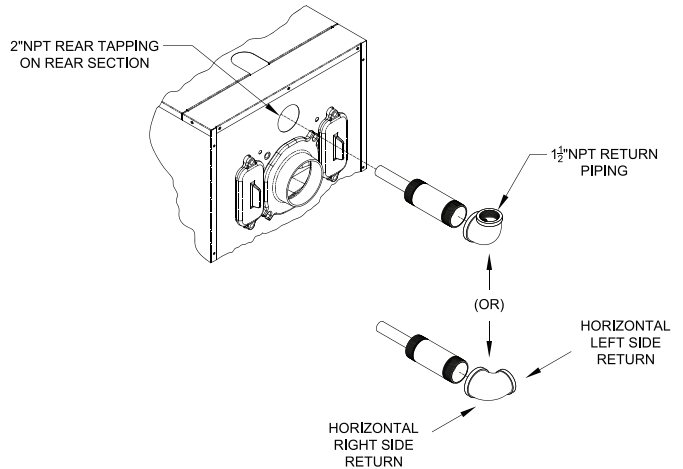

**Figure 7: Return Injector Piping and Relief Valve Assembly Details**

3. Install return injector piping and relief valve, refer to Figure 7.

Locate the return pipe fittings and injector. Apply sealant to the 2" NPT injector threads. Insert injector into 2" NPT upper rear tapping on rear section. Thread 2" NPT x 1-1/2" Reducing Elbow onto 2" NPT injector.

**NOTE:** Based on system return piping and access to service boiler, see Figures 1, 10A and 10B, predetermine if injector piping orientation is to be positioned for vertical, horizontal left or horizontal right side return piping as shown in Figure 7.

4. Install drain valve, see Figure 8.

**Step 1.** Apply pipe sealant to both ends of 1-1/4" NPT x 5" lg. nipple. Thread nipple into 1-1/4" NPT lower rear tapping on rear section.

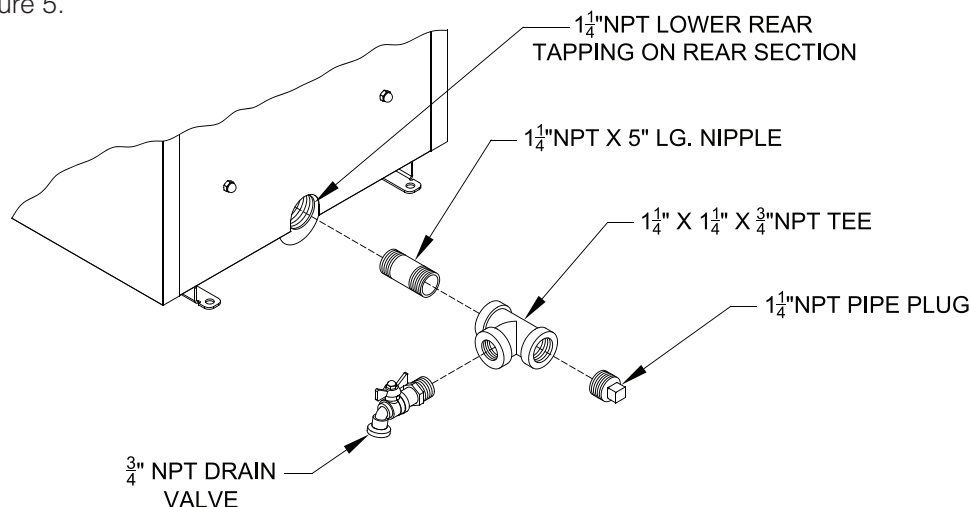

**Figure 8: Piping Arrangement for Drain Valve and Indirect Water Heating Return**

### 3 Packaged Boiler Assembly - Trim & Controls *(continued)*

**Step 2.** Thread 1-1/4" x 1-1/4" x 3/4" NPT tee on opposite end of 5" lg. nipple installed in Step a.

**NOTE:** Based on access for servicing and location of sewer or floor drain, when tightening these fittings, determine if drain valve is to be located on the left or right side.

Tighten nipple and tee into 1-1/4" NPT lower rear tapping on rear section until joints are water tight for desired position.

**Table 3: Baffle Usage**

Boiler Model	Baffle Usage		
	2 <sup>nd</sup> Pass	3 <sup>rd</sup> Pass	Combustion Chamber
FORCEOL084-E	[2] P/N 102066-01	None	None
FORCEOL115-E	[2] P/N 109902-01	[2] P/N 100081-01	[1] P/N 109901-01
FORCEOL140-E	[2]	None	None
FORCEOL182-E	P/N 100042-01	None	None

**Step 3.** Apply sealant to 3/4" NPT thread on drain valve. Thread into 3/4" NPT tapping on side outlet of tee. Use hex nut portion to tighten valve until water tight.

5. Connect Field Wiring.

Connect the field wiring from the circulator to the HydroStat 3250 control. Make the wiring connections as shown on Figures 27 and 28.

6. Installing stainless steel flueway baffles. Baffle requirements differ from model to model, see Table 3.

**NOTE:** Read caution statement **before** proceeding.

**CAUTION**

These baffles will generate higher efficiencies and lower stack temperatures. Under certain conditions, a lower gross stack temperature entering the chimney has the potential to be cooled below the dew point and create condensate on interior surfaces. Flue gas condensate is corrosive, which requires special consideration and must be addressed immediately.

**DO NOT** install baffles until you have read Sections VI and VII, completely (venting details).

Install stainless steel baffles provided in miscellaneous parts carton as follows, refer to Table 3 and Figure 9:

- FORCEOL084E - To install flueway baffle in 2<sup>nd</sup> pass on left side of boiler, hold baffle with word "Left" readable at the top. Slide baffle in flueway until position tab touches fins on left side of 2<sup>nd</sup> pass flueway. To install flueway baffle in 2<sup>nd</sup> pass flueway on right side of boiler, hold baffle with word "Right" readable at the top. Slide baffle in flueway until position tab touches fins on right side of 2<sup>nd</sup> pass flueway.
- Model EMP115E - To install flueway baffle in 3<sup>rd</sup> pass on left side of boiler, hold baffle with the word "Left" readable at the top. Slide baffle in flueway until position tab touches fins on left side of 3<sup>rd</sup> pass flueway. To install flueway baffle in 3<sup>rd</sup> pass flueway on right side of boiler, hold baffle with word "Right" readable at the top. Slide baffle in flueway until position tab touches fin on right side of 3<sup>rd</sup> pass flueway. To install flueway baffle in 2<sup>nd</sup> pass on left side of boiler, hold baffle with word "Left" readable from the top. Slide baffle in flueway until position tab touches fins on left side of 3<sup>rd</sup> pass flueway. To install flueway baffle in 2<sup>nd</sup> pass flueway on right side of boiler, hold baffle with word "Right" readable at the top. Slide baffle in flueway until position tab touches fins on right side of 3<sup>rd</sup> pass flueway.
- To install combustion chamber Ring, set ring in the front section of the combustion chamber.
- FORCEOL140-E and FORCEOL182-E To install flueway baffle in 2<sup>nd</sup> pass flueway on left side of boiler, hold baffle with word "Left" readable at the top. Slide baffle in flueway until position tab touches fins on right side of 2<sup>nd</sup> pass flueway. To install flueway baffle in 2<sup>nd</sup> pass flueway on right side of boiler, hold baffle with word "Right" readable at the top. Slide baffle in flueway until position tab touches fins on left side of 2<sup>nd</sup> pass flueway.

**NOTE:** 2<sup>nd</sup> and 3<sup>rd</sup> pass flueway baffle are not interchangeable.

### 3 Packaged Boiler Assembly - Trim & Controls *(continued)*

7. **Close the burner swing door** and securely seal the door to the boiler front section by reinstalling the hardware and securing the door using procedure previously outlined in Paragraph D of this section.

**NOTICE:** When securing burner swing door make sure door is drawn-in equally on both sides.

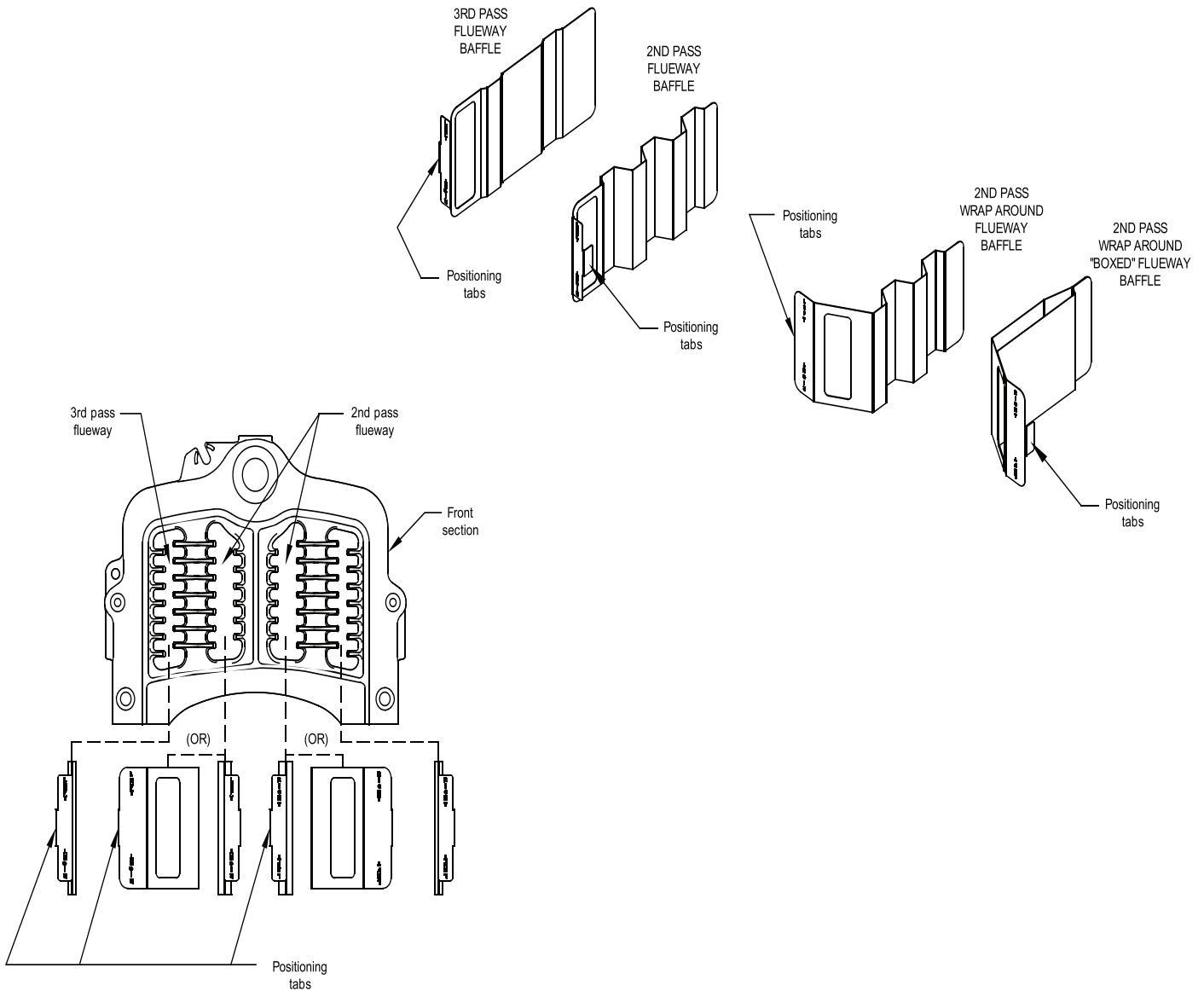

**Figure 9: Baffle Orientation in Flueways**



## 4 Water Boiler Piping

**NOTICE:** Failure to pipe boiler as specified in this manual may result in excessive system noise.

### A. EVALUATE THE EXISTING WATER SYSTEM.

Design a piping system and install boiler which will prevent oxygen contamination of boiler water and frequent water additions.

1. There are many possible causes of oxygen contamination such as:
  - a. Addition of excessive make-up water as a result of system leaks.
  - b. Absorption through open tanks and fittings.
  - c. Oxygen permeable materials in the distribution system.
2. In order to insure long product life, oxygen sources must be eliminated. This can be accomplished by taking the following measures:
  - a. Repairing system leaks to eliminate the need for addition of make-up water.
  - b. Eliminating open tanks from the system.
  - c. Eliminating and/or repairing fittings which allow oxygen absorption.
  - d. Use of non-permeable materials in the distribution system.
  - e. Isolating the boiler from the system water by installing a heat exchanger.

#### **WARNING**

System supply and return piping must be connected to correct boiler manifolds.

U.S. Boiler Company, Inc. recommends sizing the system circulator to supply sufficient flow (GPM) to allow a 20°F temperature differential in the system. When sizing the system circulator, the most restrictive single zone should be used to determine maximum pressure drop.

#### **CAUTION**

Maintain minimum ½ inch clearance from hot water piping to combustible materials.

3. In order to insure long product life, operate boiler at appropriate flow rate to minimize areas of overheating.
  - a. Design system to ensure that the flow is above the limit called for in Table 4.
  - b. Maintain a constant boiler pressure of 12 PSI.

**Table 4: Minimum Flow Rate**

Boiler Model	Flow Rate (Gal / Min)
FORCEOL084-E	4.5
FORCEOL115-E	4.5
FORCEOL140-E	8.0
FORCEOL182-E	10.0

#### **WARNING**

Do not operate boiler below minimum volumetric flow rates.

### B. CONNECT SYSTEM SUPPLY AND RETURN PIPING TO BOILER.

See Figures 10A and 10B. Also, consult Residential Hydronic Heating Installation and Design I=B=R Guide.

1. If this boiler is used in connection with refrigeration systems, the boiler must be installed so that the chilled medium is piped in parallel with the heating boiler using appropriate valves to prevent the chilled medium from entering the boiler. See Figure 11. Also, consult Residential Hydronic Heating Installation and Design I=B=R Guide.
2. If this boiler is connected to heating coils located in air handling units where they may be exposed to refrigerated air, the boiler piping must be equipped with flow control valves to prevent gravity circulation of boiler water during the operation of the cooling system.
3. If an indirect water heater is used, priority zoning can be used. Do not use priority zoning for Hydro-Air Systems. Refer to the Indirect Water Heater Installation, Operating, and Service Instructions for additional information.
4. The FORCE OIL is designed to withstand thermal shock from return water temperatures as low as 100°F, but prolonged return temperatures of below 135°F can cause excessive flue gas condensation and damage the boiler and/or venting system. Use a boiler bypass if the boiler is to be operated in a system which has a large volume or excessive radiation where low boiler water temperatures may be encountered (i.e. converted gravity circulation system, etc.) The bypass should be the same size as the supply and return lines with valves located in the bypass and return line as illustrated in Figures 10A and 10B in order to regulate water flow for maintenance of higher boiler water temperature.

# 4 Water Boiler Piping (continued)

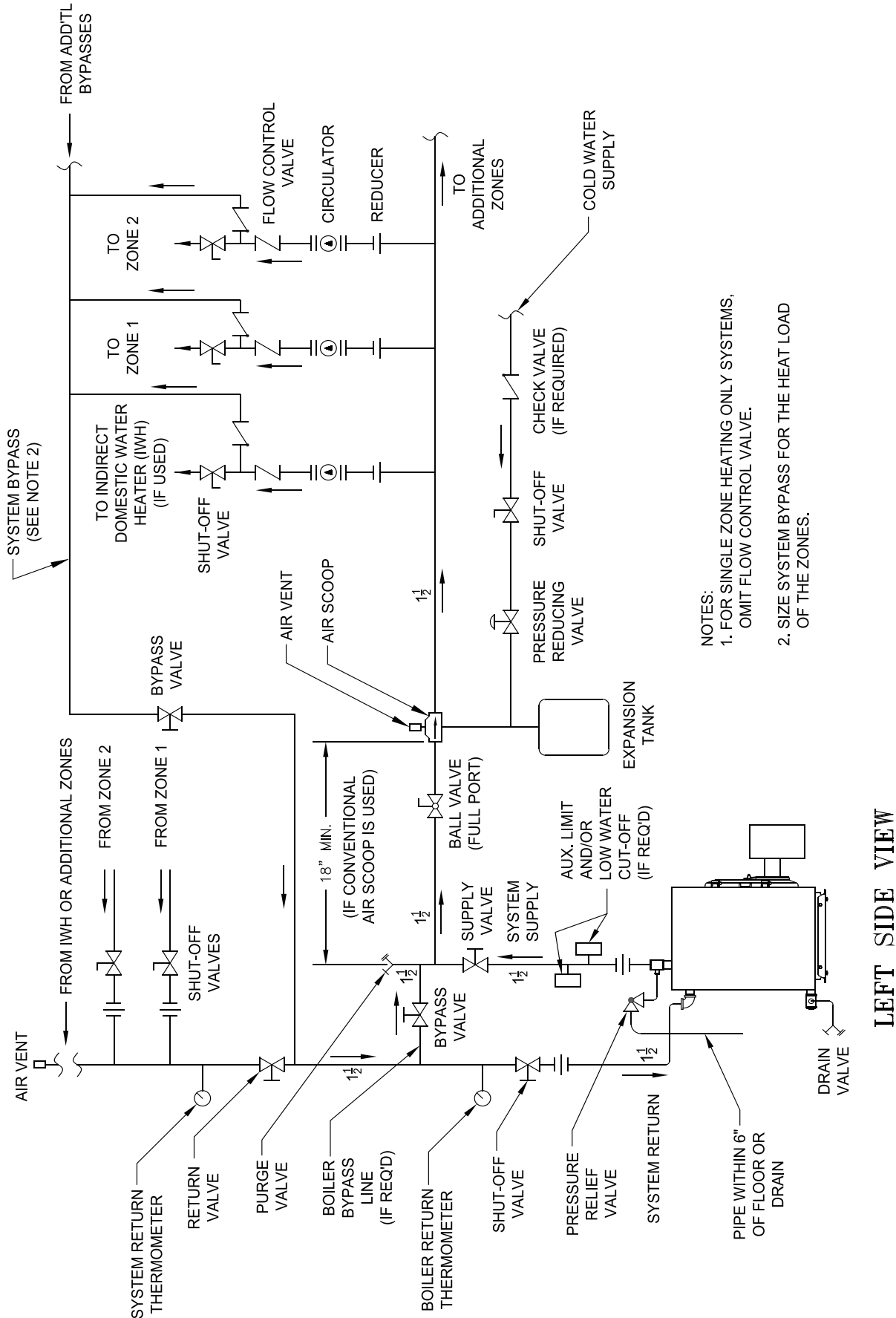

- NOTES:
1. FOR SINGLE ZONE HEATING ONLY SYSTEMS, OMIT FLOW CONTROL VALVE.
  2. SIZE SYSTEM BYPASS FOR THE HEAT LOAD OF THE ZONES.

Figure 10A: Recommended Water Piping for Circulator Zoned Heating Systems - Supply Side Circulator

# 4 Water Boiler Piping (continued)

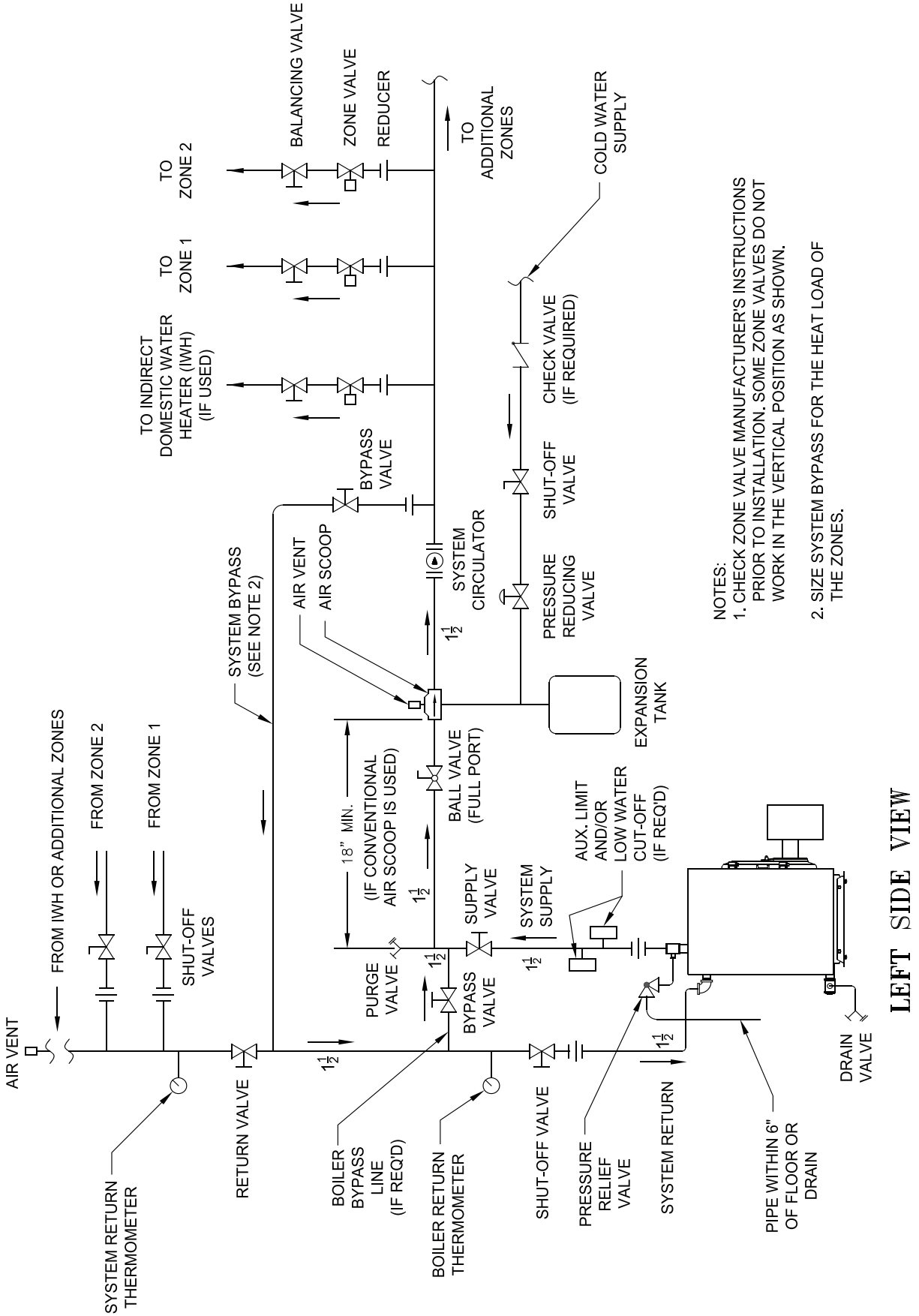

NOTES:  
 1. CHECK ZONE VALVE MANUFACTURER'S INSTRUCTIONS PRIOR TO INSTALLATION. SOME ZONE VALVES DO NOT WORK IN THE VERTICAL POSITION AS SHOWN.  
 2. SIZE SYSTEM BYPASS FOR THE HEAT LOAD OF THE ZONES.

LEFT SIDE VIEW

Figure 10B: Recommended Water Piping for Zone Valve Zoned Heating Systems - Supply Side Circulator

## 4 Water Boiler Piping *(continued)*

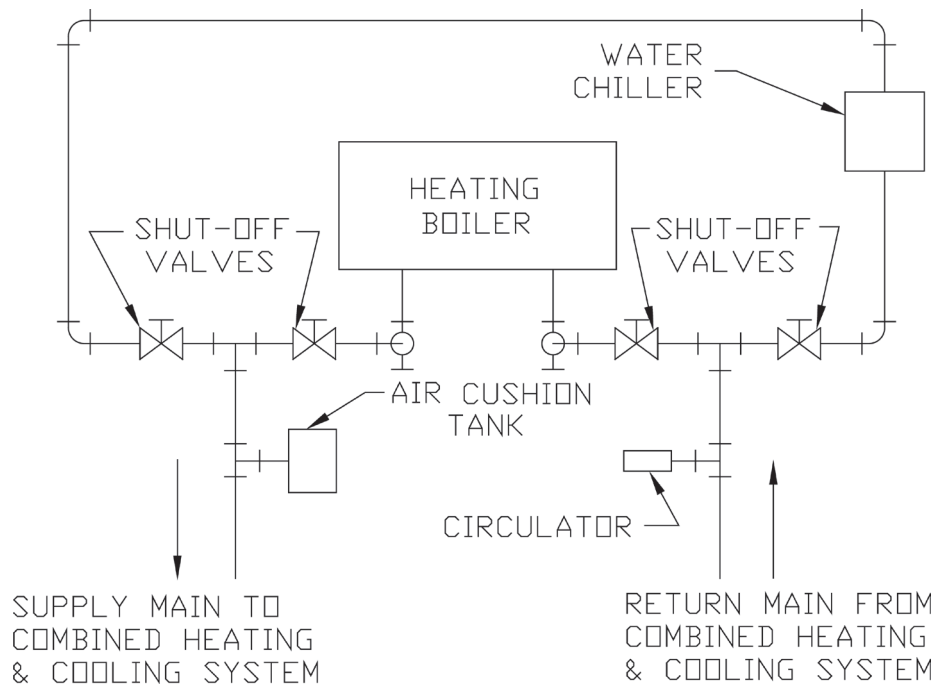

**Figure 11: Recommended Piping for Combination Heating and Cooling (Refrigeration) System**

### **⚠ WARNING**

The use of a low water cut-off device, while not required unless radiation level is below the boiler, is highly recommended.

If a low water cut-off is required, it must be mounted in the system piping above the boiler. The minimum safe water level of a hot water boiler is just above the highest water containing cavity of the boiler; that is, a hot water boiler must be full of water to operate safely.

5. **If it is required to perform a long term pressure test of the hydronic system**, the boiler should first be isolated from the system to avoid a pressure loss due to the escape of air trapped in the boiler.

To perform a long term pressure test including the boiler, ALL trapped air must first be removed from the boiler.

A loss of pressure during such a test, with no visible water leakage, is an indication that the boiler contained trapped air.

# 5 Indirect Water Heater Piping

## A. CONNECT INDIRECT DOMESTIC WATER HEATER PIPING as shown in Figures 12A and 12B.

Also refer to Figures 10A and 10B.

Refer to instructions furnished with Indirect Water Heater for additional information.

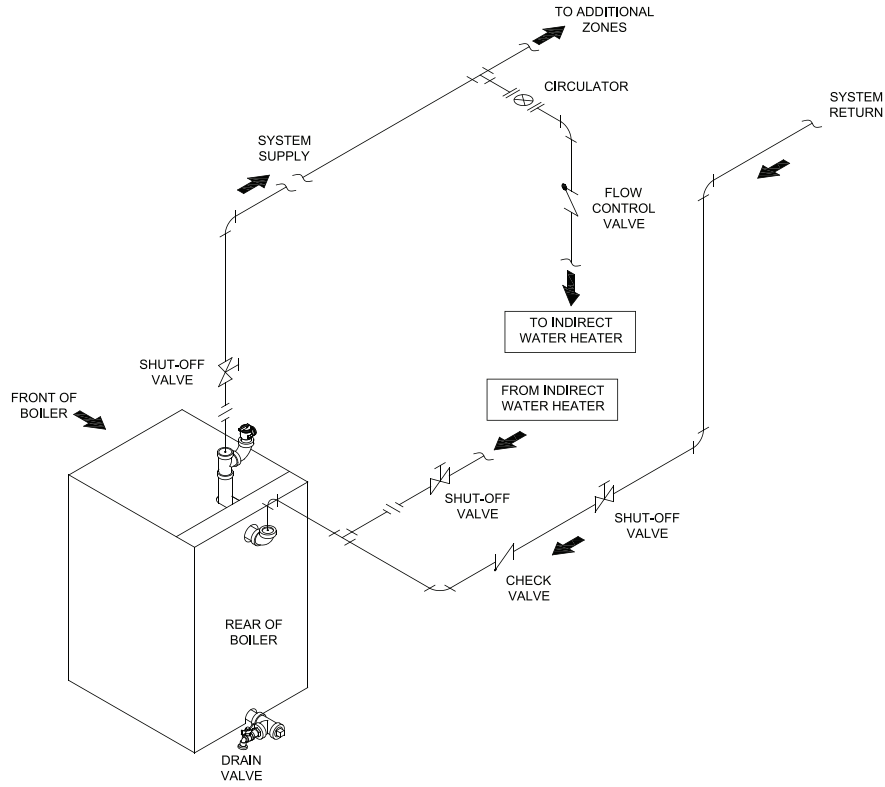

**Figure 12A: Indirect Water Heater Piping w/Supply Side Circulator on Circulator Zoned Heating System**

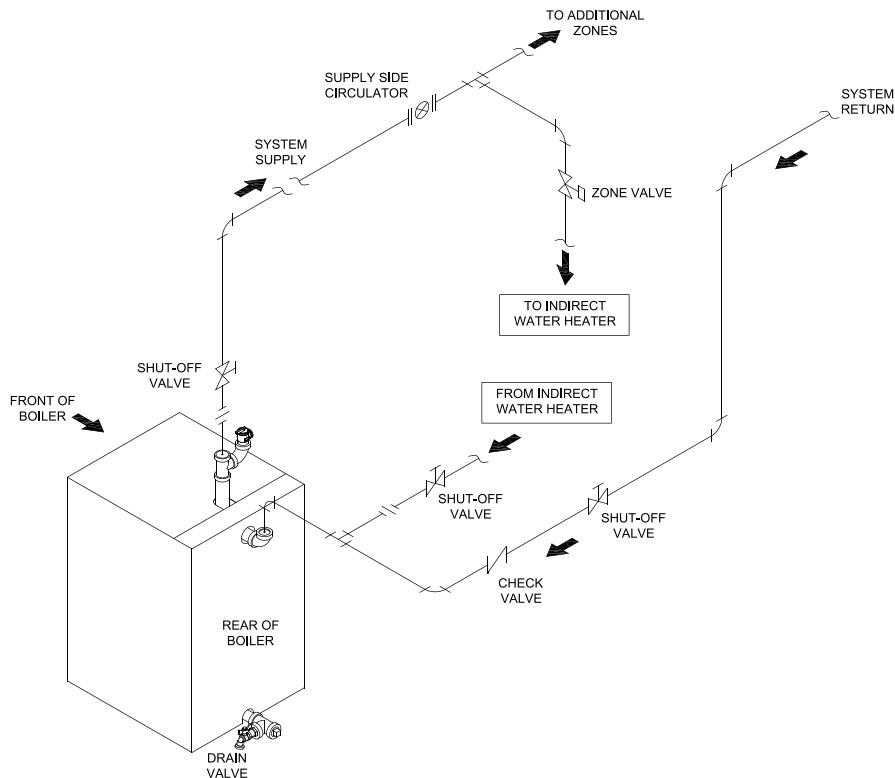

**Figure 12B: Indirect Water Heater Piping w/Supply Side Circulator on Zone Valve Zoned Heating System**

## 6 Natural Draft Venting (Chimney)

### WARNING

- Vent this boiler according to these supplemental instructions. Failure to do so may cause products of combustion to enter the home resulting in severe property damage, personal injury or death.
- Insufficient Combustion Air Supply may result in the production and release of deadly carbon monoxide (CO) into the home which can cause severe personal injury or death.
- Improper venting may result in property damage and the release of flue gases which contain deadly carbon monoxide (CO) into the home, which can cause severe personal injury, death, or substantial property damage.
- Inspect existing chimney and vent connector for obstructions and deterioration before installing boiler. Failure to clean or replace perforated pipe or chimney liner will cause severe injury or death.
- Do not de-rate the appliance. Failure to fire the boiler at it's designed input may cause excessive condensation upon the interior walls of the chimney. In addition, the lower input may not create enough draft to adequately evacuate the by-products of combustion.

### A. CHIMNEY VENTING

1. Chimney venting is an important part of a safe and efficient oil fired appliance system. Contact your local fire and building officials on specific requirements for restrictions and the installation of fuel oil burning equipment. In addition, consult with a professional knowledgeable on the requirements of NFPA 31 – Standard for the Installation of Oil-Burning Equipment and NFPA 211 - Standard for Chimneys, Fireplaces, Vents, and Solid Fuel-Burning Appliances for installations in the United States. Installations in Canada must be reviewed with a professional knowledgeable on the requirements of CSA B139 – Installation Code for Oil-burning Equipment.
2. The safe venting of oil fired boilers is dependant on many factors. Some of these factors include:
  - a. sufficient draft during the entire heating season to allow for the safe discharge of combustion by-products and;
  - b. suitable corrosion protection in the event of condensing flue gases. Only a trained and qualified contractor may install this product.
3. The FORCE OIL shall be vented into any of the following:
  - a. Masonry or metal chimney. Build and install in accordance with local buildings codes; or local authority having jurisdiction; or “Standards for Chimney, Fireplace, Vents, and Solid Fuel Burning Appliances”, ANSI/ NFPA 211 and/or National Building Code of Canada. Masonry chimney must be lined with listed chimney system. Listed clay flue lined masonry chimneys meet venting requirements.
    - External chimneys are more susceptible to flue gas condensation due to colder outside air temperatures. To prevent corrosion due to flue gas condensation, use a listed corrosion-resistant metal liner in chimney.
  - b. Oversized chimneys are more susceptible to flue gas condensation. To reduce the likelihood of flue gas condensation and ensure proper draft, use a properly sized listed metal liner in oversized chimney.
4. Chimney Inspection – Prior to the installation of any new or replacement fuel burning equipment the chimney shall be inspected by a qualified installer. The chimney shall be inspected for integrity as well as for proper draft and condensate control. Some jurisdictions require the use of a liner when changing fuel types. Some jurisdictions require the use of a liner even when the same fuel is used. At a minimum, the chimney shall be examined by a qualified person in accordance with the requirements of Chapter 11 of NFPA 211, Standard for Chimneys, Fireplaces, Vents, and Solid Fuel-Burning Appliances.
  - a. Loose Mortar – Loose mortar could be an indication of a prior history of condensing flue gases upon the inside walls of the chimney. Colder climates are more susceptible to this condition. Under no circumstances shall a chimney of this condition be used until it meets the requirements of NFPA 211 or CSA B139.
  - b. Unlined Chimney – Under no circumstances shall a chimney constructed of brick only be used. Only approved clay liners or listed chimney lining systems shall be used as specified in NFPA 31 or CSA B139.
  - c. Abandoned Openings – Openings through the chimney wall that are no longer used shall be sealed in accordance to NFPA 211. Often abandoned openings are improperly sealed and usually covered by a gypsum wall covering.
  - d. Clean Chimney – Chimney shall be free of all loose debris.

# 6 Natural Draft Venting (Chimney) *(continued)*

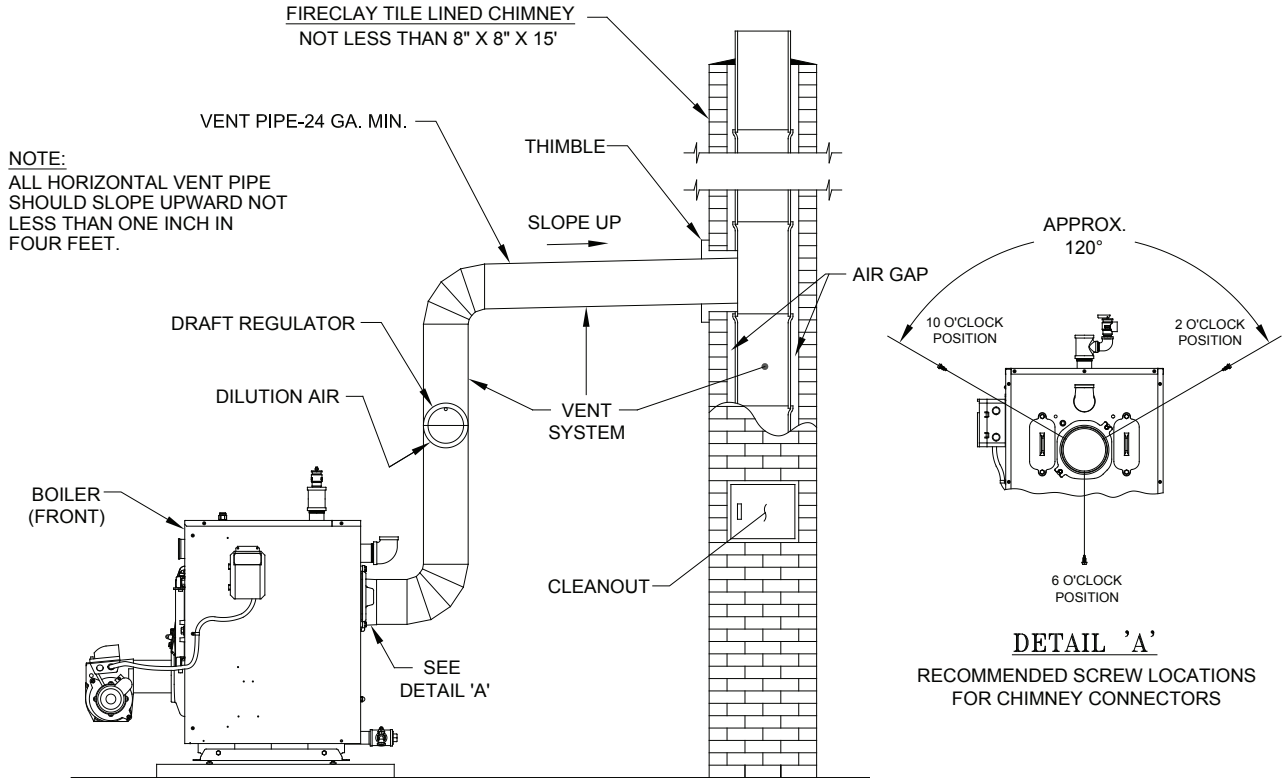

**Figure 13: Recommended Vent Pipe Arrangement and Chimney Requirements**

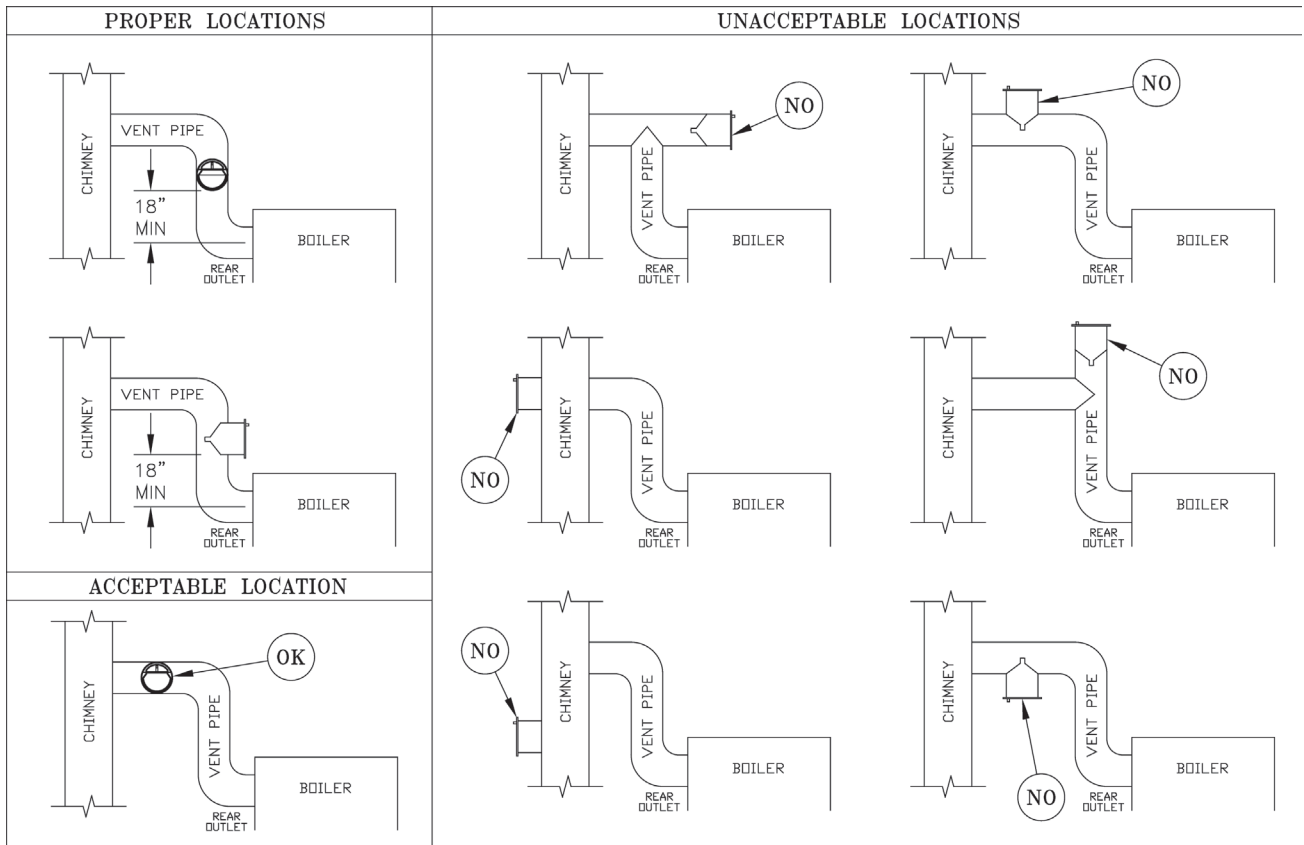

**Figure 14: Proper and Improper Locations of Draft Regulator**

## 6 Natural Draft Venting (Chimney) *(continued)*

- Draft Regulator – a draft regulator (not supplied with boiler) must be used with this appliance. Refer to Figures 13 and 14.

### B. CHIMNEY CONNECTOR

- A chimney connector (vent pipe) is used to connect the boiler to the base of the chimney. The chimney connector should be kept as short as possible. The horizontal length of the chimney connector shall not be greater than 10 feet.

NOTE: Secure chimney connector to cast iron smokebox collar with three (3) #10 x 1/2" self drilling hex head TEK screws provided in miscellaneous parts carton. Locate screws around perimeter of connector as shown in Figure 15 and approximately 1/2" in from edge. Use drill with 5/16" hex bit to drive screws through connector and smokebox collar.

#### **⚠ DANGER**

The chimney and connector shall be inspected annually for signs of debris and corrosion. Loose mortar at the base of the chimney may be a sign of condensate damage to the chimney. A chimney professional shall be contacted immediately to examine the damage and recommend a solution. Long term operation while in this condition may cause a venting failure and force flue gases into the living space. If the chimney is to be re-lined use the recommendations in NFPA 31, Appendix E or CSA B139.

- Vent Connector shall be any of the following and of the same size as the outlet of boiler.
  - Type L or a factory built chimney material that complies with the Type HT requirements of ANSI/UL 103. Install in accordance with listing and manufacturer's instructions.
  - Steel pipe having resistance to corrosion and heat with a minimum wall thickness of 24 Gauge (0.024").

#### **⚠ DANGER**

Any signs of condensate seepage at the base of the chimney shall be inspected immediately. The discoloration may be a sign of chimney damage and must be remedied immediately.

### C. DRAFT

- The natural draft generated through a chimney is dependent on several factors including, chimney height, temperature of flue gases, cross section area of chimney, chimney wall insulation value, dilution air and total volume of flue gases, to name a few. Make sure that the boiler has been running for at least 5 minutes before measuring the draft.
- Minimum Draft at Breech (Canopy) – The draft induced by a chimney must create at least a pressure of 0 (zero) inches water column (" w.c.) at the pressure tapping on the canopy mounted on rear of boiler (see Figure 15). The pressure at the canopy cannot be positive since this could create a condition that allows flue gas by-products to escape from the draft regulator. A negative pressure reading up to -.03 inches water column is acceptable for proper operation. (See Tables 9 and 10 Burner Specifications at the rear of this manual for more details)
- Minimum Overfire Pressure – The overfire pressure is another piece of information that is often measured, however this should be done for observation purposes only! The breech pressure must be used to qualify the draft condition. See Tables 9 and 10 for more details as a guide. Actual draft and temperature measurements may be different than those values in the table.

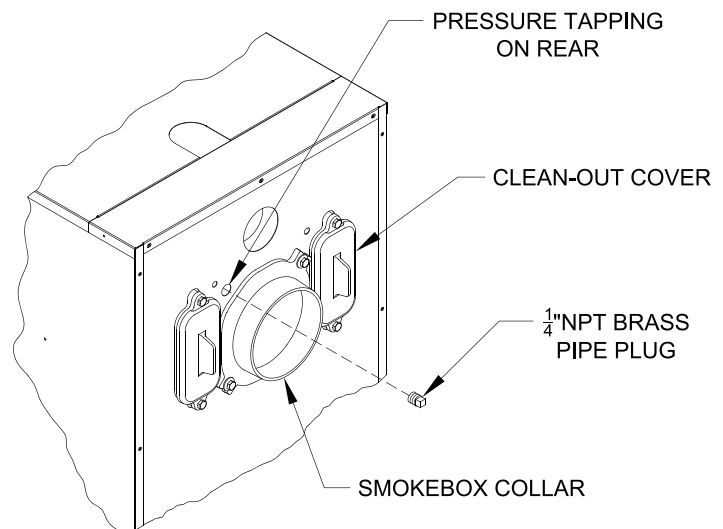

**Figure 15: Smokebox Pressure Tapping for Checking Draft at Breech**



## 6 Natural Draft Venting (Chimney) *(continued)*

### D. STACK TEMPERATURE

1. The temperature of the flue gases has a significant effect on the amount of draft created in a vertical chimney as well as the propensity to create condensate. The higher the stack temperature, the greater the amount of draft that can be generated. A lower stack temperature not only reduces the amount of draft that can be created but it also increases the possibility that the flue gases could condense in the chimney connector or stack.
2. NFPA 31 and CSA B139 have information to help the installer make an appropriate choice of venting materials. In some cases a chimney may have to be lined to create sufficient draft. In other cases, the chimney may have to be lined to prevent the corrosion of a masonry chimney. Consult with a chimney specialist knowledgeable on the requirements for chimney requirements in your area.

#### CAUTION

Any doubt on the condition of a chimney or its ability to prevent the generation and accumulation of flue gas condensate, must be relined according to NFPA 31 (United States) or CSA B139 (Canada).

#### CAUTION

Use the chimney venting tables as a guide. It is highly recommended that any borderline application should result in the relining of the chimney with a suitable liner that creates sufficient draft and to protect against corrosion caused by flue gas condensate.

3. Baffles – The efficiency of the boiler is based on the insertion of flue baffles supplied with your product. Under no circumstances are other baffles to be used on this product. Refer to Section III, Item F, Paragraph 6 for baffle installation. If there is any doubt on the application of this boiler on the intended chimney, consult with your local code officials. At a minimum, remove the baffles to increase the stack temperature. See Tables 9 and 10 for temperature differential ( $\Delta T$ ) with baffles IN and OUT. In addition, the lower the  $CO_2$  level the higher the stack temperature.

#### WARNING

Remove the baffles if there are any signs of condensation in the chimney or chimney connector. Consult with your local chimney professional for recommendations.

### E. MINIMUM CLEARANCES

See Figure 2A for details regarding clearances to combustibles for the boiler.

## 7 Direct Venting / Air Intake Piping

### A. GENERAL GUIDELINES

1. Direct Vent system must be installed in accordance with these instructions and applicable provisions of local building codes. Contact your local fire and building officials on specific requirements for restrictions and the installation of fuel oil burning equipment. In addition, for boiler installation in United States, consult with a professional knowledgeable on requirements of NFPA 31- *Standard for the Installation of Oil-Burning Equipment* and NFPA 211 *Standard for Chimney, Fireplaces, Vents and Solid Fuel-Burning Appliances*, latest editions.
2. In the Direct Vent configuration, all air for combustion is supplied directly to the burner from outdoors, and, flue gases are vented directly outdoors (thru wall), via Direct Vent System (FDVS), which is a non-positive pressure vent system termination for oil-fired appliances, that provides an outlet for products of combustion, and, an intake for combustion air in a single concentric terminal.
3. Direct Vent Hood Assembly minimum clearance to combustible material is 0".
4. Maximum wall thickness that FDVS vent termination may be installed through is 12".

### ⚠ WARNING

This venting system must be installed by a qualified installer (an individual who has been properly trained) or a licensed installer.

DO NOT locate vent termination where exposed to prevailing wind. Moisture and ice may form on surfaces around vent termination. To prevent deterioration, surface must be in good repair (sealed, painted etc.).

DO NOT locate vent termination where petroleum distillates, CFC's, detergents, volatile vapors or any other chemicals are present. Severe boiler corrosion and failure will result. DO NOT locate vent termination under a deck.

5. Locate the vent terminal so vent pipe is short and direct, and, at the place on exterior wall that complies with the minimum distances as specified in Figure 16 and listed as follows. The vent termination must be located (as measured to the bottom of vent terminal):
  - a. Not less than 12" above finished grade or expected snow accumulation line whichever is greater.
  - b. Not less than 3 ft above any forced air inlet located within 10 ft.
  - c. Not less than 4 ft from any door, window or gravity air inlet.

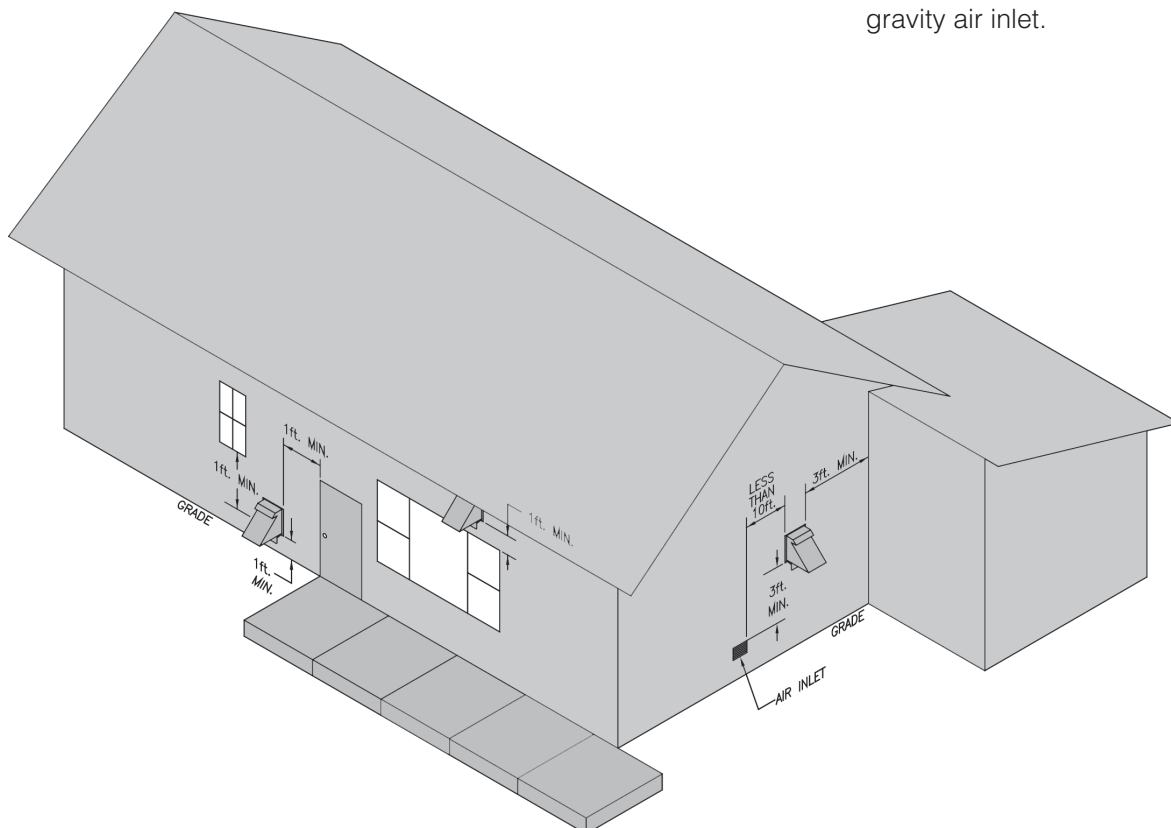

Figure 16: Vent Terminal Location

## 7 Direct Venting / Air Intake Piping *(continued)*

- d. Not less than 7 ft above grade when located above public walkway.
- e. Not less than 3 ft (as measured to side of vent termination) from an inside corner of an L-shaped structure.
- f. Not less than 1 ft from the nearest surface of the terminal to a roof soffit.
- g. Not directly above, or, not less than 6 ft horizontally from an oil tank vent or gas meter.
- h. Not less than 2 ft from nearest surface of terminal to an adjacent building.

### B. INSTALLATION OF THE VENT HOOD TERMINAL

(see Figures 17, 18, 19 and 20)

1. Inspect Direct Vent Conversion Kit Carton for damage. DO NOT install if any damage is evident.
2. Direct Vent Conversion Kit Carton includes:
  - Direct Vent Hood Assembly (consists of Vent Hood Body and Combustion Air Tee) – 1 pc
  - Backing Plate – 1 pc
  - Vacuum Relief Valve VRV-4 – 1 pc
  - Hardware Bag (includes high temperature sealant, fasteners and inner pipe clamps) – 1 pc
  - Appliance Adapter – 1 pc
  - Appliance Clamp Halves – 2 pcs
  - Cover Sleeve Assemblies – 2 pcs
  - Cover Ring Assemblies – 2 pcs
3. Remove vent system components from carton and set aside.
4. Separate the vent hood tee from the vent hood body and set aside for later use.
5. After determining the location of the venting system termination, cut the square hole in the wall sized according to "L" dimension in Table 5, see Figure 17.
6. Wood or vinyl siding should be cut, so that vent hood base plate mounts directly on the wallboard to provide stable support. If siding thickness exceeds ½", use a spacer bar or board behind the vent hood mounting (base) plate. See Figure 18.
  - a. Seal the backside of the vent hood base plate around the outer pipe of the vent hood with a bead of high-temperature silicone sealant.
  - b. Mount the vent hood body from outside, through the wall, keeping the outer pipe centered in the hole.
  - c. Fasten the vent hood body to the outside wall with appropriate fasteners (installer provided).

**Table 5: Wall Cutout Dimensions**

Boiler Model	Direct Vent Conversion Kit Part No.	"L" Dimension (Inch)
FORCEOL140-E FORCEOL182-E	106401-01	8¼

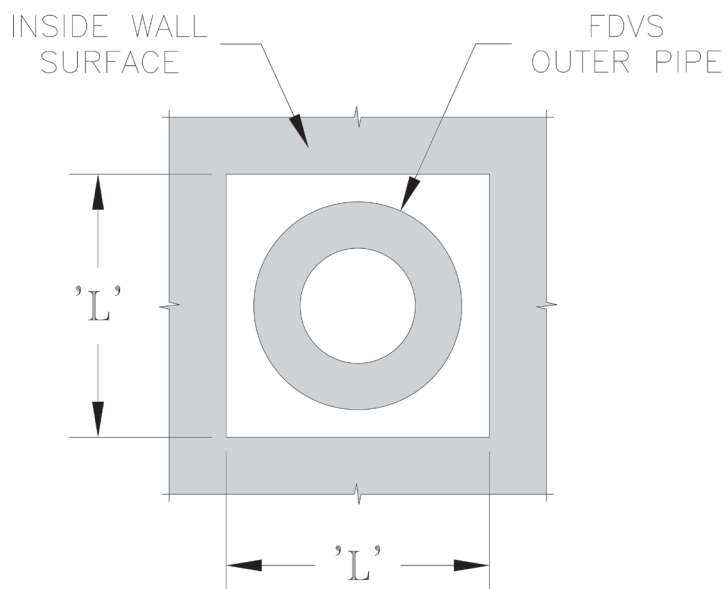

**Figure 17: Wall Cutout Dimensions**

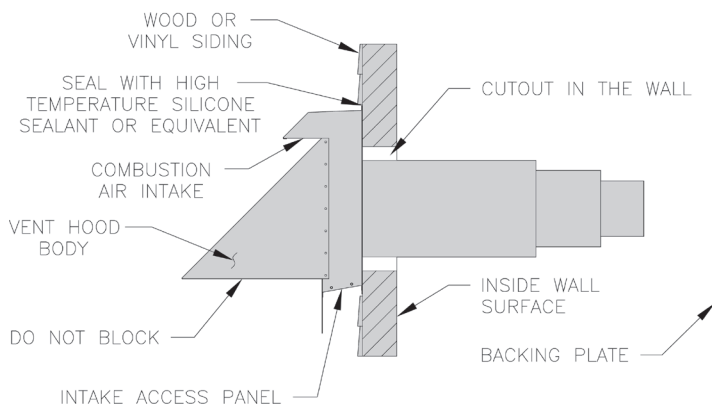

**Figure 18: Vent Hood Body Installation**

- d. Seal the edges of the vent hood base plate to the wall with a high-temperature silicone sealant.
- e. While inside, position the backing plate over the outer pipe and fasten to inside wall with appropriate fasteners (installer provided).

## 7 Direct Venting / Air Intake Piping (continued)

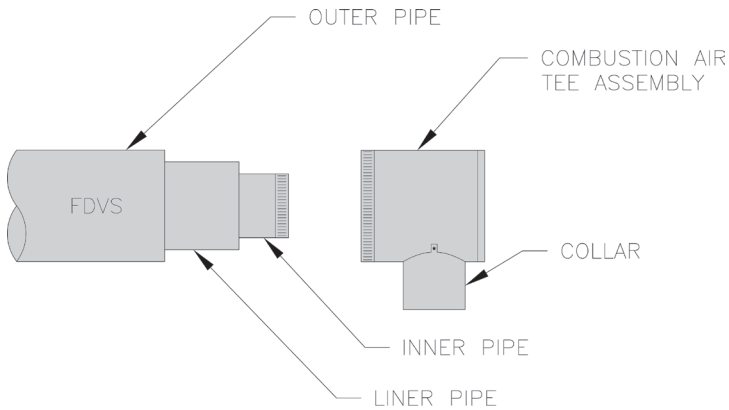

**Figure 19: Combustion Air Tee Assembly Installation**

### C. INSTALLATION OF VENT HOOD TEE

1. Assemble the vent hood tee body to the vent hood outer pipe, and, rotate the tee, so air intake inlet collar is in the desired position. See Figure 19.
2. Attach the vent hood tee body to the vent hood outer pipe with at least three sheet metal screws (installer provided).

**NOTE:** The tee may be rotated into any position so that the collar is in a convenient orientation.

3. After completing assembly of the flexible double wall insulated vent pipe to the vent termination inner pipe (see Figure 20 and the following Steps), apply the supplied high temperature sealant to seal around the inner pipe protrusion thru the vent tee cover pan, around the joint between the vent tee collar and the vent tee body, and, seal or tape the joint between the vent termination outer pipe and the vent tee body.

### D. INSTALLING THE FLEX OIL VENT PIPE FROM THE VENT TERMINATION TO THE BOILER FLUE OUTLET

1. The venting system (vent pipe and all connectors) shall be installed in accordance with the applicable provisions of any local codes, and, in United States, requirements of NFPA 31- *Standard for the Installation of Oil-Burning Equipment* and NFPA 211 *Standard for Chimney, Fireplaces, Vents and Solid Fuel-Burning Appliances*, latest editions.
2. A vent pipe connector, designed for positive pressure venting, shall be supported for the design and weight of material employed, to maintain clearances, prevent physical damage and separation of joints. All joints **MUST BE** sealed, for positive vent pressure, to prevent flue gas leakage into the structure.
3. Support the vent pipe at intervals no greater than three (3) feet apart using perforated metal strap or other non-combustible supports.
4. Allow sealant to cure at least one hour before firing boiler.
5. Route the vent pipe from the vent termination to the boiler using the minimum number of bends possible. The last horizontal section of the vent pipe should have a slight downward slope from the boiler to the vent termination. For clearances to combustible materials refer to Figure 2B.
6. Maximum length of flexible oil vent pipe is 20 ft. The vent pipe is also available pre-cut in 10 ft.
7. Verify that flex vent pipe diameter and vent termination inner pipe diameter correspond to a particular direct vent configuration FORCE OIL boiler model (see Table 6).

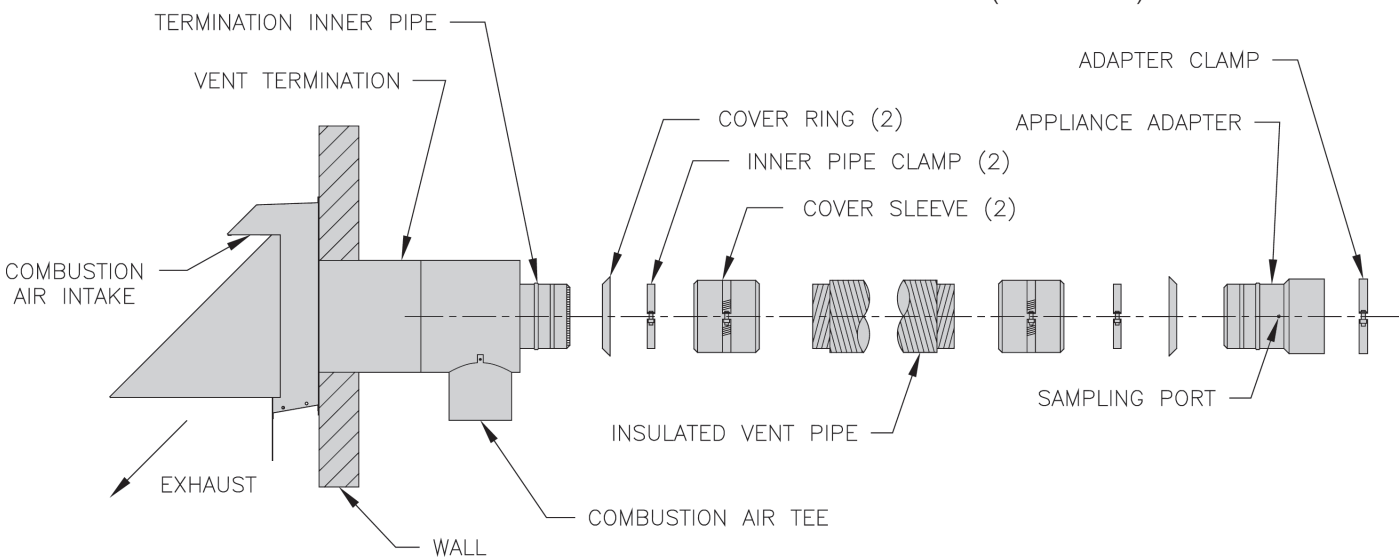

**Figure 20: FDVS Component Breakdown**

## 7 Direct Venting / Air Intake Piping *(continued)*

**Table 6: Flex Vent / Vent Termination Pipe Diameters**

Boiler Model	Boiler Flue Outlet Collar OD (Inch)	Vent Hood Inner Pipe Diameter (Inch)	Flex Oil Vent Pipe Inner Pipe Diameter (Inch)	* Flue Outlet Collar to Vent Pipe Adapter (Inch)
FORCEOL140-E	6	5	5	6 to 5
FORCEOL182-E				

**NOTE:** \* The model specific Direct Vent (FDVS) Kit Cartons contain adapters (reducers) (see Table 6) to connect boiler flue outlet collar to vent pipe.

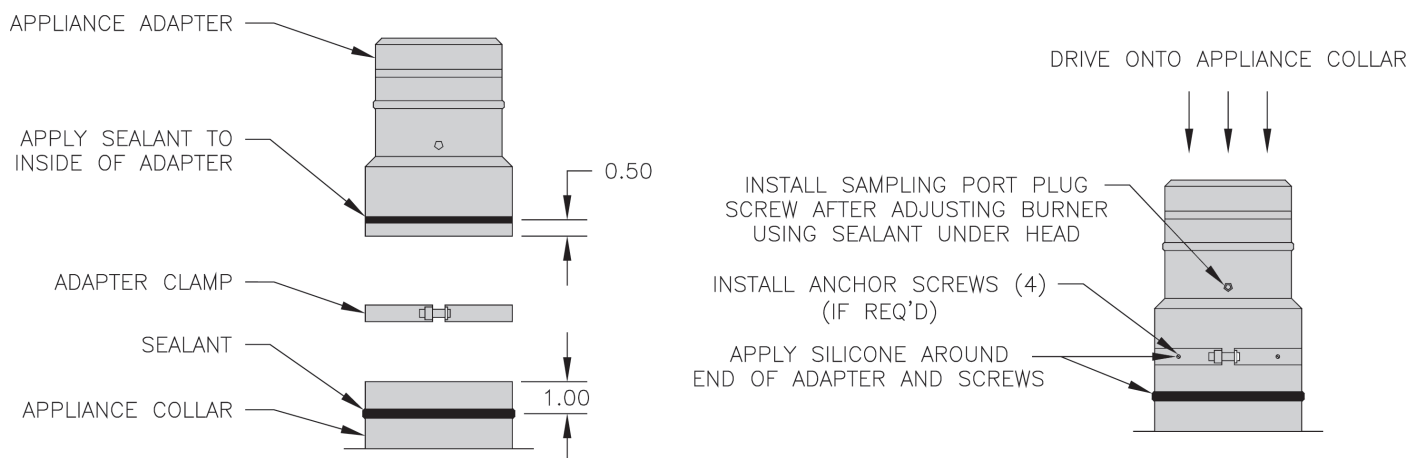

**Figure 21: Appliance Adapter Installation**

### E. CONNECTING APPLIANCE ADAPTER TO BOILER FLUE OUTLET COLLAR

(See Figure 21) reimburse

1. Apply a bead of supplied high temperature sealant to boiler flue outlet collar approximately 1" from collar end.
2. Remove any oil and grease from inside of supplied Appliance (Boiler Flue Outlet) Adapter, and, apply a bead of high temperature sealant to inside of the adapter, 1/2" from end.
3. With twisting motion, assemble the appliance adapter onto boiler flue outlet collar.
4. Using a mallet and a block of wood, carefully tap the adapter onto the outlet collar. Insure no damage is done to the adapter and the flue outlet collar.
5. Assemble supplied adapter clamp halves with 5/16-18 bolts and square nuts; install the adapter clamp onto the appliance adapter and tighten securely.
6. If required, install anchoring screws (installer provided) thru four holes in the clamp into the flue outlet collar.
7. Apply sealant around the adapter end mated to the flue outlet collar.

8. Install supplied 3/8" sampling port plug screw hand tight into the adapter sampling port.
9. **After initial boiler start-up and burner testing/adjustment are completed**, apply high temperature sealant under the head of sampling port plug screw, and, install the screw in the sampling port tightening securely.

### F. CONNECTING FLEX OIL VENT PIPE TO APPLIANCE ADAPTER AND DIRECT VENT TERMINATION

1. Flexible double wall oil vent pipe is available pre-cut in 5 ft and 20 ft length. If necessary, the vent pipe may be cut to required length with a hacksaw or cutoff saw.

#### **CAUTION**

Use safety glasses and other appropriated safety gear when cutting the vent pipe.

2. The double wall flexible vent pipe consists of the smaller inner corrugated stainless steel pipe and larger corrugated aluminum pipe, separated by fiberglass insulation layer.

## 7 Direct Venting / Air Intake Piping *(continued)*

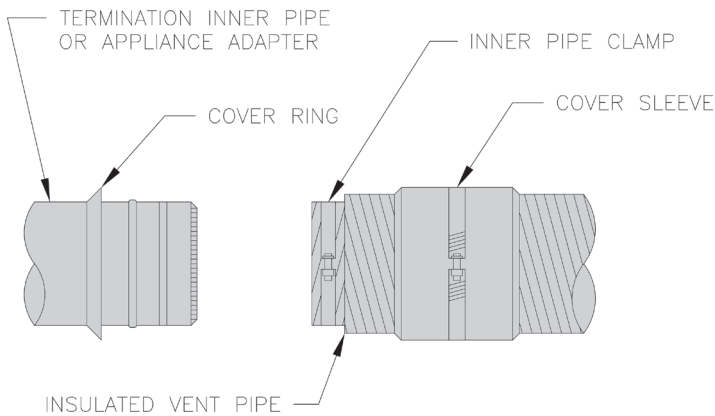
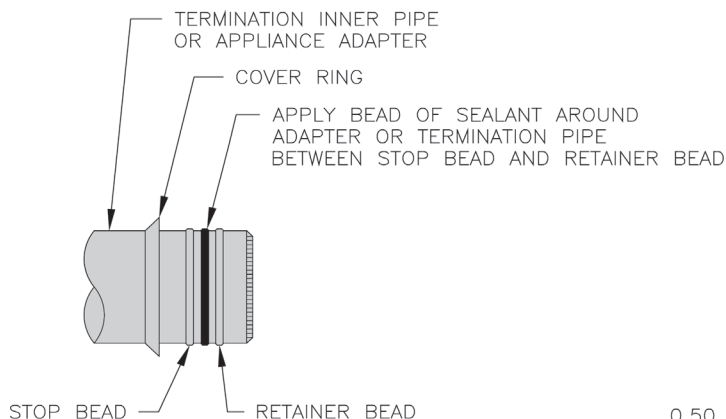

**Figure 22: Vent Pipe Assembly to Vent Termination Inner Pipe and Appliance Adapter**

### CAUTION

The inner and outer pipe ends may have sharp burrs. Use gloves, while handling, compressing or expanding the vent pipe.

3. Pull outer vent pipe back 1" to 2" from end of inner vent pipe and remove insulation; firstly, at vent pipe end to be connected to the vent termination; secondly, at vent pipe end to be connected to the appliance adapter. See Figure 22.
4. Install supplied Cover Sleeve Assembly onto each end of outer vent pipe, and, move the assembly a few inches back from the end; firstly, at vent pipe side to be connected to the vent termination; secondly, at vent pipe side to be connected to the appliance (boiler outlet collar) adapter. See Figure 22.
5. Slide supplied Cover Rings; firstly, over stop bead on vent termination inner pipe; secondly, over stop bead on appliance adapter. See Figure 22.
6. Remove any oil and grease from the end of vent termination inner pipe, and, from the end of the appliance adapter.



**Figure 23: Vent Pipe Ends, Vent Termination and Appliance Adapter Sealing**

7. Apply sealant; firstly, between the stop bead and retainer bead at the end of the vent termination inner pipe; secondly, between the stop bead and retainer bead at the end of the appliance adapter. See Figure 23.
8. Assemble supplied inner pipe clamp halves with 1/4-20 bolts and square nuts; position the inner pipe clamps 1/4" from the end of inner vent pipe, on vent pipe opposite ends.
9. Remove any oil and grease from inside of each end of the inner vent pipe.
10. Apply a thick bead of sealant to inside of each end of the inner vent pipe, 1/2" from pipe end, working the sealant into the inner vent pipe corrugations. See Figure 23.
11. Firstly, push one end of the inner vent pipe onto the vent termination inner pipe, all the way up to the stop bead. Secondly, push the opposite end of the inner vent pipe onto the appliance adapter, all the way up to the stop bead.
12. Tighten the inner pipe clamp bolts at both vent pipe ends, until clamp halves are within 1/8" apart. See Figure 24.
13. Starting with vent termination end, slide the cover sleeve assembly and the cover ring together to engage the ring in the groove of the sleeve, then, tighten the built-in cover sleeve clamp. Repeat above steps at the boiler end. See Figure 24.
14. If the appliance collar is within less than 18" of combustible material, wrap minimum 1-1/2" thick fiberglass insulation (installer provided).
15. To maintain vent pipe 1" clearance to combustible material, wrap minimum 1-1/2" thick fiberglass insulation (installer provided) around the exposed portion of the vent termination inner pipe and secure with adhesive-backed aluminum foil tape (installer provided).

## 7 Direct Venting / Air Intake Piping (continued)

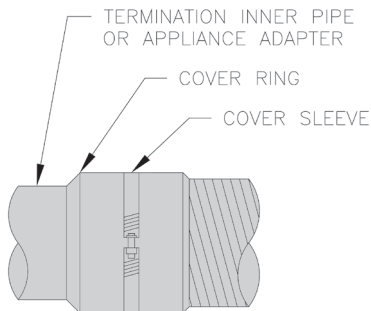
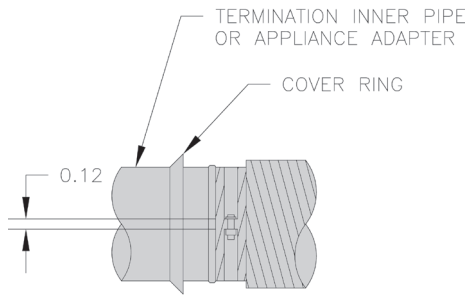
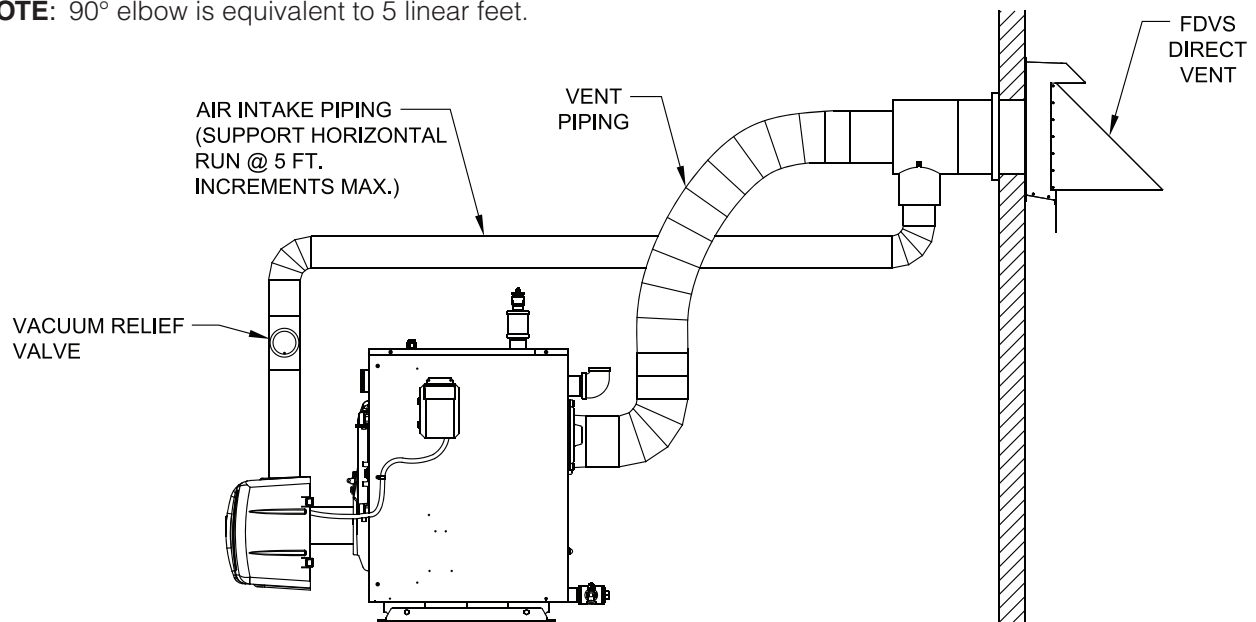

**Figure 24: Vent Pipe Assembly to Vent Termination Inner Pipe & Appliance Adapter**

### G. INSTALLING THE AIR INTAKE PIPING FROM DIRECT VENT TERMINATION TO BURNER OUTSIDE AIR ADAPTER

1. Use 4" diameter galvanized single wall vent pipe and fittings, available at most heating distributors, to connect burner outside air adapter to Direct Vent Termination air intake collar. See Figure 25.
2. Maximum air intake pipe length is 40 equivalent feet.

**NOTE:** 90° elbow is equivalent to 5 linear feet.



**Figure 25: Install Air Intake Piping and Vacuum Relief Valve**

### ⚠ WARNING

DO NOT reduce size of air intake pipe.

3. Remove burner from carton. Secure burner to boiler with mounting hardware included with burner swing door. See Figure 26.
4. Remove knockout for 4" vent pipe collar from burner cover. See Figure 26.
5. Start at burner and work towards Direct Vent termination air intake.
6. Procure a 2-ft section of 4" diameter galvanized single wall vent pipe, cut off the crimped pipe end below stop bead.
7. Insert one end of the vent pipe thru the outside air duct bracket opening and firmly push onto the outside air adapter collar.
8. Secure the pipe to collar with at least (3) sheet metal screws (installer provided) evenly spaced around the collar.

**NOTICE:** It is essential to ensure reliable operation that combustion air joints are air tight and that VRV is located as close to the burner as possible.

9. Install supplied vacuum relief valve tee assembly, crimped end down, into the opposite end of vent pipe.
10. Secure the tee to the pipe with at least (3) sheet metal screws (installer provided) evenly spaced.
11. Remove the vacuum relief valve gate assembly from the tee.

## 7 Direct Venting / Air Intake Piping *(continued)*

12. Assemble the vacuum relief valve balance weight onto the gate. Refer to the vacuum relief valve manufacturer's instructions for details.
13. Mount the assembled vacuum relief valve gate with balance weight into the tee and fasten with a screw and nut in collar tabs. To insure proper operation, the gate must be level across the pivot point and plumb. Refer to the vacuum relief valve manufacturer's instructions for details.
14. Install remainder of air intake piping to Direct Vent Termination air intake collar, securing each joint with at least (3) sheet metal screws (installer provided) evenly spaced.
15. Maintain  $\frac{1}{4}$ " per foot slope in horizontal run to air intake of Direct Vent Termination.
16. Support the air intake piping, as required, using perforated metal strap or other supports.
17. Refer to Burner Manufacturer's Manual for addition information.

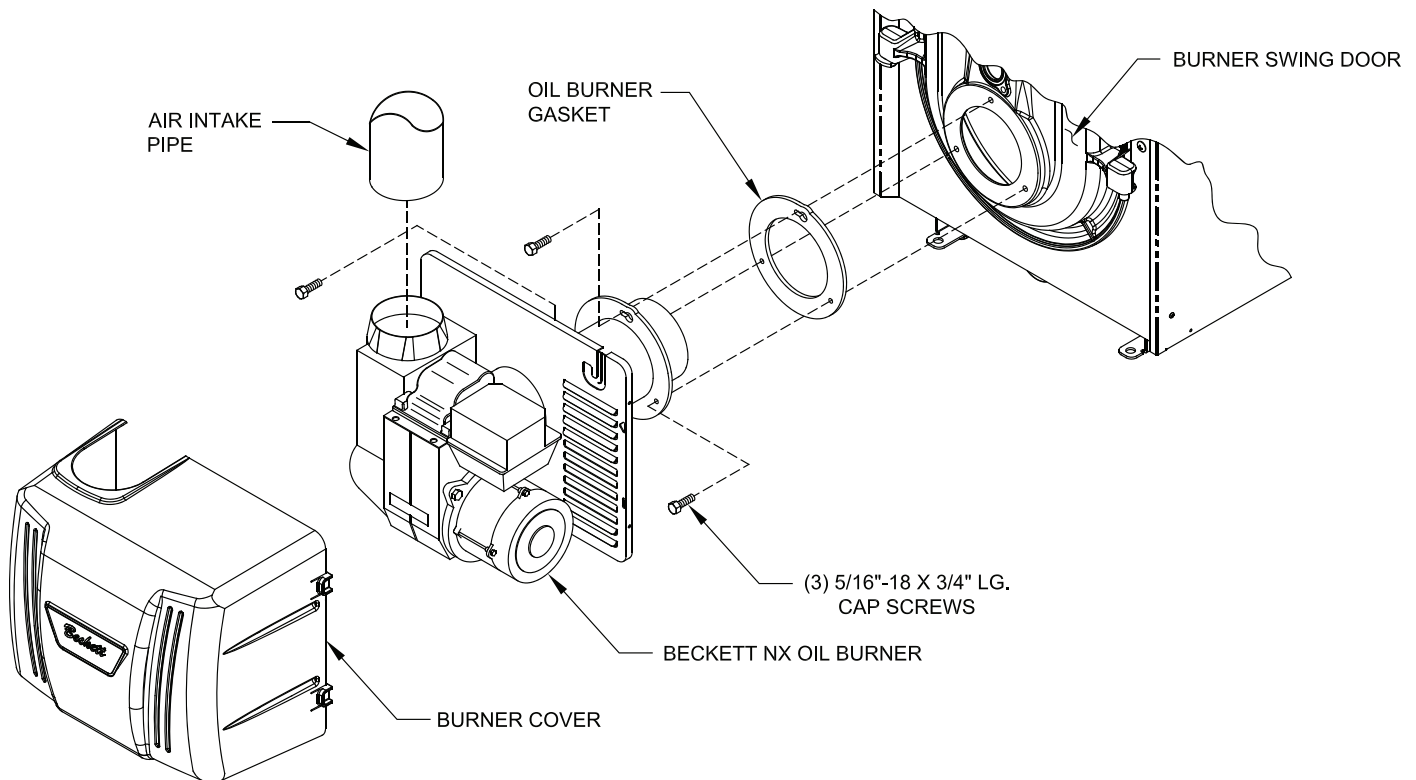

**Figure 26: Oil Burner Installation (NX Beckett shown)**



## 8 Electrical

### DANGER

Positively assure all electrical connections are unpowered before attempting installation or service of electrical components or connections of the boiler or building. Lock out all electrical boxes with padlock once power is turned off.

### WARNING

- Failure to properly wire electrical connections to the boiler may result in serious physical harm.
- Electrical power may be from more than one source. Make sure all power is off before attempting any electrical work.
- Each boiler must be protected with a properly sized fused disconnect.
- Never jump out or make inoperative any safety or operating controls.

#### A. GENERAL

1. Install wiring and electrically ground boiler in accordance with requirements of the authority having jurisdiction, or in absence of such requirements the *National Electrical Code*, ANSI/NFPA 70.
2. Refer to *National Electric Code* or Local Electric Codes for proper size and type of wire required. Follow Code.
3. A separate electrical circuit must be run from the main electrical service with an over-current device/disconnect in the circuit. A service switch is recommended and may be required by some local jurisdictions.
4. Use anti-short bushings on all wiring passing through boiler jacket, junction boxes and/or control boxes.
5. Use armored cable (BX) over all exposed line voltage wiring.
6. If an indirect domestic water heater is used, use priority zoning. Do not use priority zoning for Hydro-Air Systems.

7. Wiring should conform to Figures 27, 28, and 29.

- B. INSTALL A ROOM THERMOSTAT** on an inside wall about four feet above floor. Never install thermostat on an outside wall or where it will be influenced by drafts, hot or cold water pipes, lighting fixtures, television, rays of the sun or near a fireplace. Keep large furniture away from thermostat so there will be free movement of room air around this control.

Heat Anticipator in Thermostat should be set to match the requirements of the control to which it is connected. See Figures 27 and 28 for desired system and heat anticipator setting. If system tends to overheat above the thermostat's temperature setting, reduce heat anticipator setting by .1 or .2 amps. If system tends to short cycle without reaching desired room temperature, increase heat anticipator setting by .1 or .2 amps.

8 Electrical (continued)

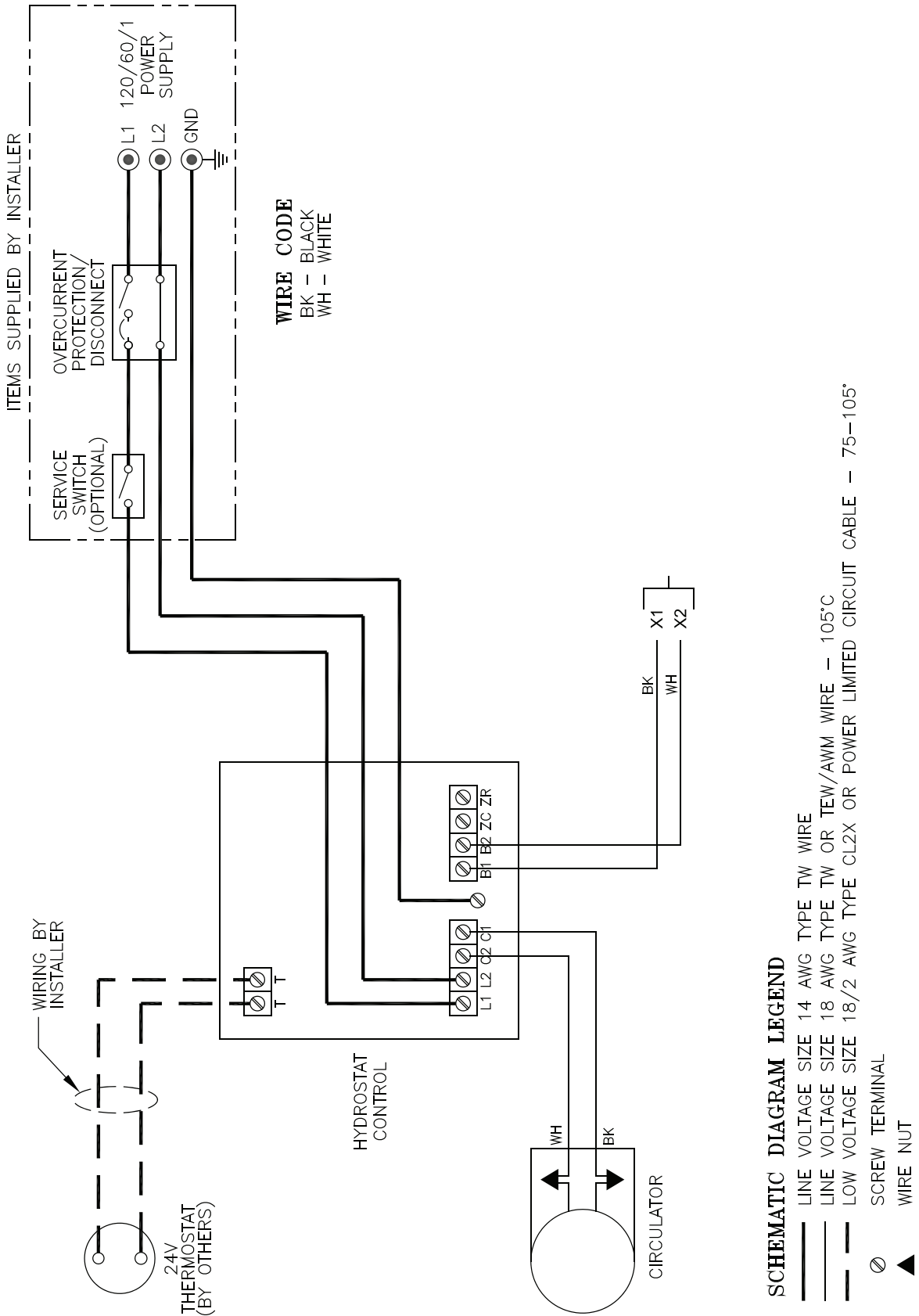
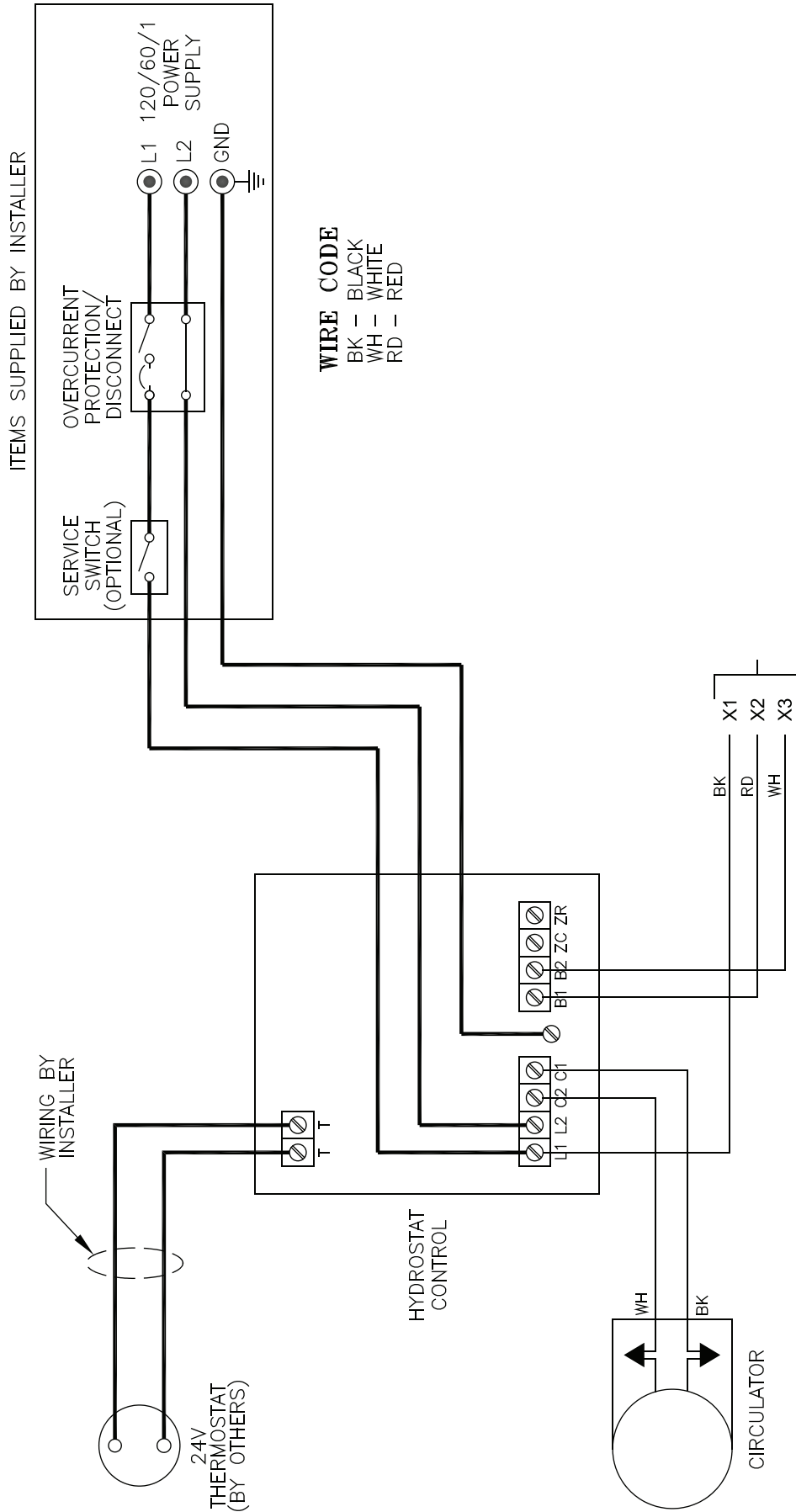

Figure 27: Schematic Wiring Diagram HydroStat 3250 Control with Beckett AFG Series Burners

# 8 Electrical *(continued)*



### SCHEMATIC DIAGRAM LEGEND

- LINE VOLTAGE SIZE 14 AWG TYPE TW WIRE
- LINE VOLTAGE SIZE 18 AWG TYPE TW OR TEW/AWM WIRE - 105°C
- LOW VOLTAGE SIZE 18/2 AWG TYPE CL2X OR POWER LIMITED CIRCUIT CABLE - 75-105°
- ⊙ SCREW TERMINAL
- ▲ WIRE NUT

Figure 28: Schematic Wiring Diagram HydroStat Control to Beckett NX Burners

# 8 Electrical (continued)

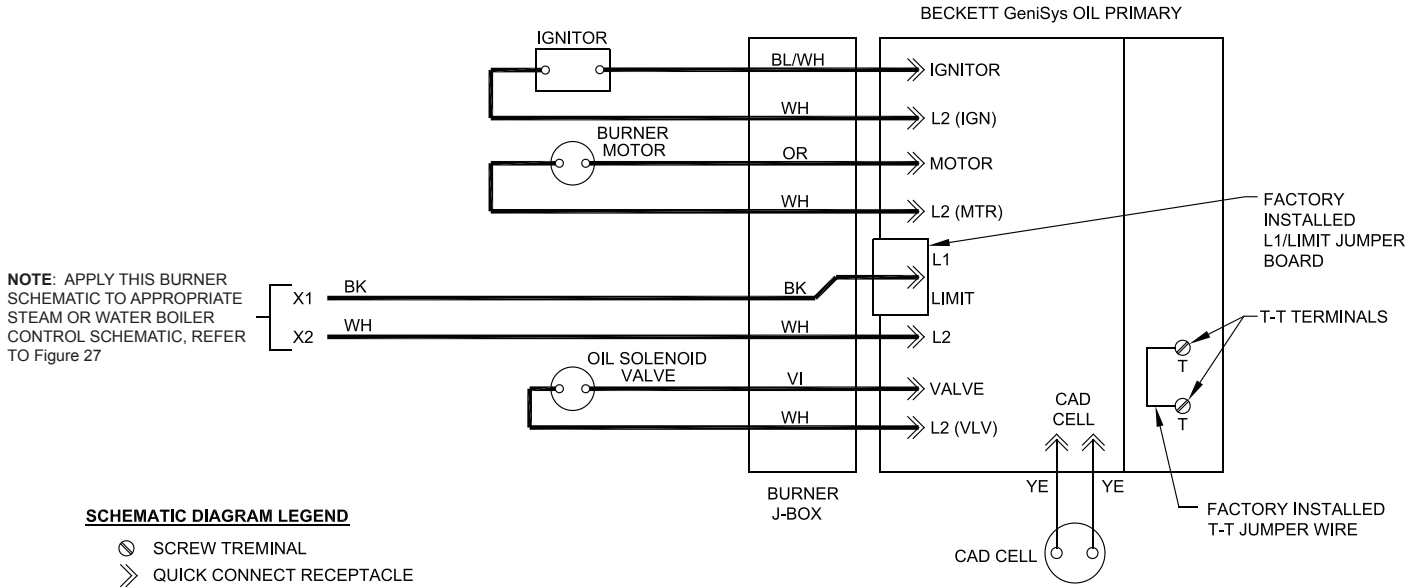

**BECKETT AFG BURNER WITH GeniSys OIL PRIMARY CONTROL**

**WIRE COLORS**

- BK - BLACK
- BL/WH - BLUE W/ WHITE TRACER
- WH - WHITE
- VI - VIOLET
- YE - YELLOW
- OR - ORANGE
- RD - RED

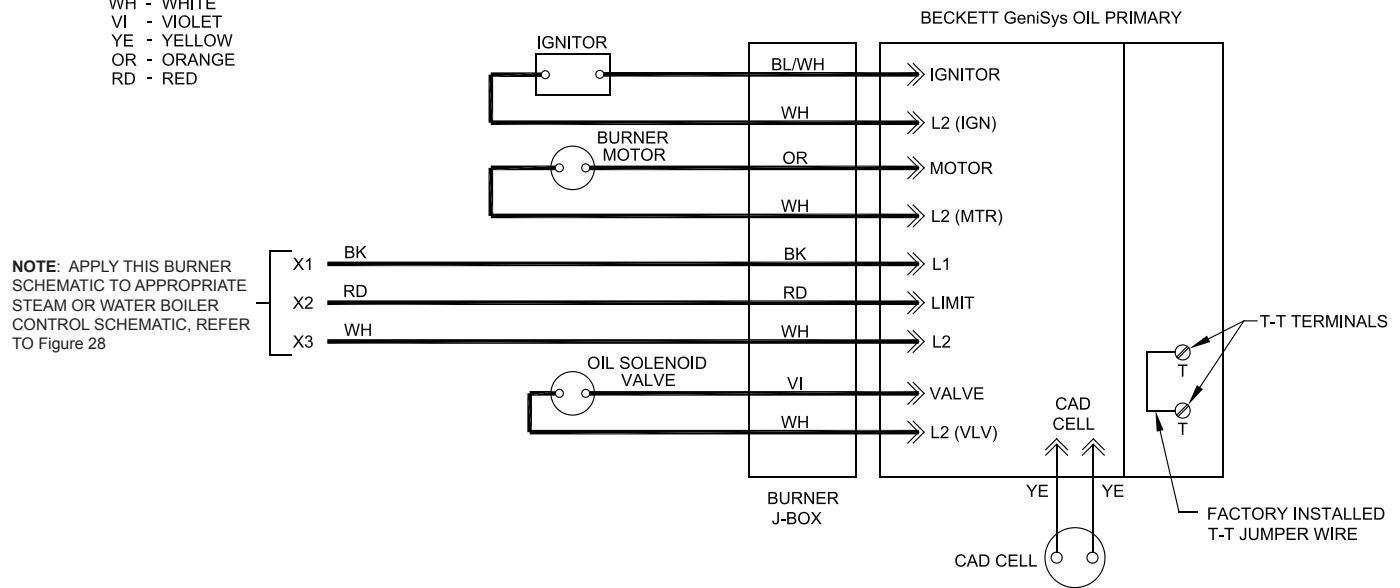

**BECKETT NX BURNER WITH GeniSys OIL PRIMARY CONTROL**

**WIRE TYPE LEGEND**

- LOW VOLTAGE FACTORY WIRING (SIZE 18 AWG, 105°C)
- - - - - LOW VOLTAGE FIELD WIRING
- LINE VOLTAGE FACTORY WIRING (SIZE 18 AWG, 105°C)
- - - - - LINE VOLTAGE FIELD WIRING

**NOTES:**

1. IF ANY ORIGINAL EQUIPMENT WIRE AS SUPPLIED WITH THE APPLIANCE MUST BE REPLACED, IT MUST BE REPLACED WITH WIRE HAVING THE SAME WIRE GAUGE (AWG), SAME WIRE TYPE, AND RATED FOR A MINIMUM OF 105°C.

**Figure 29: Schematic Wiring Diagrams**

## 9 Oil Piping

### A. GENERAL

1. Use flexible oil line(s) so the burner swing door can be opened without disconnecting the oil supply piping.
2. A supply line fuel oil filter is recommended as a minimum for all firing rates but a pleated paper fuel oil filter is recommended for the firing rates below 1.0 GPH to prevent nozzle fouling.
3. Use Flared fittings only. Cast iron fittings cannot be used.

**NOTICE:** Do not use compression fittings.

Oil piping must be absolutely airtight or leaks or loss of prime may result. Bleed line and fuel unit completely.

Refer to your local jurisdictions regarding any special considerations for fuel supply requirements. In addition, refer to NFPA 31, *Standard for the Installation of Oil-Burning Equipment*.

4. Use of a high efficiency micron filter (Garber or equivalent) in addition to a conventional filter is highly recommended.
5. Piping used to connect the oil burner to the oil supply tank shall not be smaller than 3/8" iron pipe or 3/8" OD copper tubing. Copper tubing shall have a .032" minimum wall thickness.

### ⚠ WARNING

Under no circumstances can copper with sweat style connectors be used.

**NOTICE:** Some jurisdictions require the use of a fusible shutoff valve at the tank and/or the burner. In addition, some jurisdictions require the use of a fusible electrical interlock with the burner circuit. Check your local Codes for special requirements.

### B. SINGLE PIPE OIL LINES

1. Standard burners are provided with single-stage 3450 RPM fuel units with the bypass plug removed for single-pipe installations.
2. The single-stage fuel unit may be installed single-pipe with gravity feed or lift. Maximum allowable lift is 8 feet. See Figure 30.
3. Fuel Oil Line Deaerator – On many occasions a leaky oil delivery line can introduce air into the fuel oil supply system. This often creates a rough starting condition and can create a burner lockout state. In addition to fixing the leak, a fuel line deaerator can be installed to eliminate air. The single line from the fuel tank is connected to the deaerator. The burner pump must be connected to the deaerator as a two pipe system. Follow the oil pump manufacturer's recommendations for conversion to a two pipe system.

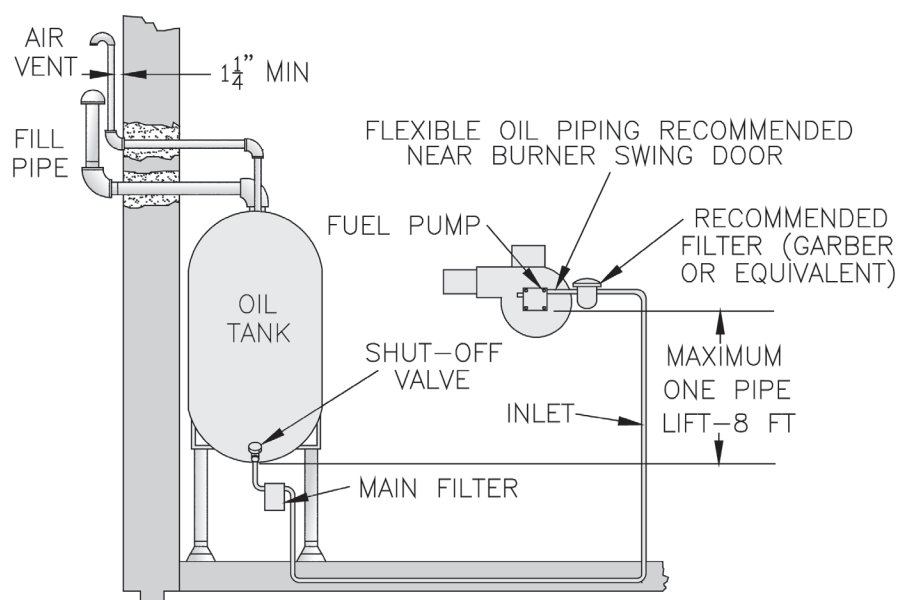

Figure 30: Single Pipe Oil Line

# 9 Oil Piping *(continued)*

## C. TWO PIPE OIL LINES

1. For two piped systems, where more lift is required, the two-stage fuel unit is recommended. Table 7 (two-stage) and Table 8 (single-stage) show allowable lift and lengths of 3/8 inch and 1/2 inch OD tubing for both suction and return lines. Refer to Figure 31.
2. Follow the oil pump manufacturer's recommendations on the proper connections for a two pipe system. Some manufacturers require the insertion of a bypass plug.

3. Under no circumstances is a manual shutoff valve to be located on the return line of a two pipe system. Accidental closure of the return line will rupture the oil pump seals.

**Table 7: Two-Stage Units (3450 RPM) - Two Pipe Systems**

Lift "H"	Maximum Length of Tubing "H" + "R" (See Figure)	
	3/8" OD Tubing (3 GPH)	1/2" OD Tubing (3 GPH)
0'	93'	100'
2'	85'	100'
4'	77'	100'
6'	69'	100'
8'	69'	100'
10'	52'	100'
12'	44'	100'
14'	36'	100'
16'	27'	100'
18'	---	76'

**Table 8: Single-Stage Units (3450 RPM) - Two Pipe Systems**

Lift "H"	Maximum Length of Tubing "H" + "R" (See Figure)	
	3/8" OD Tubing (3 GPH)	1/2" OD Tubing (3 GPH)
0'	84'	100'
1'	78'	100'
2'	73'	100'
3'	68'	100'
4'	63'	100'
5'	57'	100'
6'	52'	100'
7'	47'	100'
8'	42'	100'
9'	36'	100'
10'	31'	76'
11'	26'	100'
12'	21'	83'
13'	---	62'
14'	---	41'

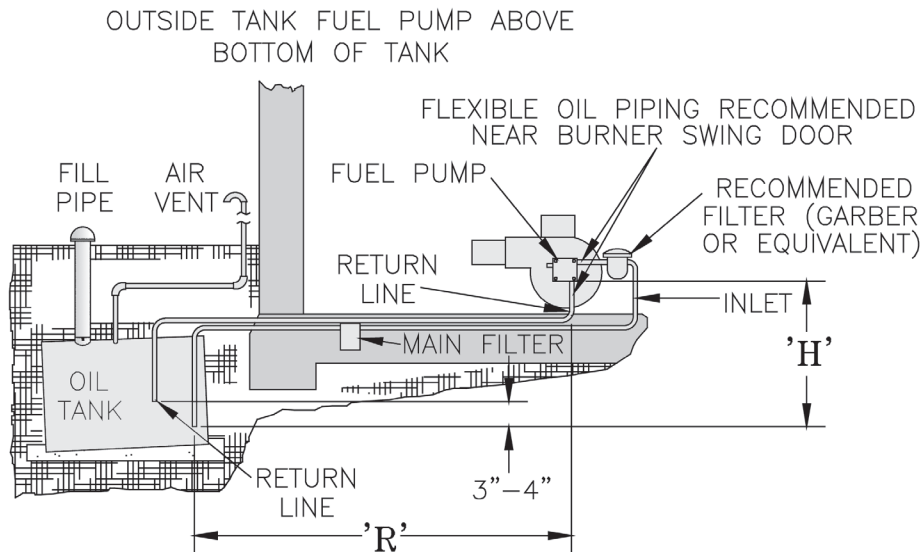

**Figure 31: Two Pipe Oil Lines**

# 10 System Start-Up

## WARNING

All boilers equipped with burner swing doors have a potential hazard which can cause severe property damage, personal injury or loss of life if ignored. Before opening swing door, turn off service switch to boiler to prevent accidental firing of burner outside the combustion chamber. Be sure to tighten swing door fastener completely when service is completed. In addition, the burner power cord will have to be disconnected from the receptacle in the front jacket.

### A. ALWAYS INSPECT INSTALLATION BEFORE STARTING BURNER.

1. Verify that the venting, water piping, oil piping, and electrical system are installed properly. Refer to Installation Instructions contained in this manual.
2. Confirm all electrical, water and oil supplies are turned off at the source and that the vent is clear from obstructions.

## WARNING

Completely read, understand and follow all instructions in this manual before attempting start up.

### B. FILL HEATING SYSTEM WITH WATER.

**NOTICE:** It is important to properly remove the oil and dirt from the system. Failure to clean the system can result in clogged air vents, circulator damage and seized zone valves.

CLEAN HEATING SYSTEM if boiler water is dirty.

Refer to Maintenance and Service Instructions Section of this manual for proper cleaning instructions for water boilers.

1. **HOT WATER BOILERS.** Fill entire heating system with water and vent air from system. Use the following procedure on a series loop or multi-zoned system installed as per Figures 10A and 10B, to remove air from system when filling:
  - a. Close full port ball valve in boiler system piping.
  - b. Isolate all zones by closing zone valves or shut-off valves in supply and return of each zone(s).
  - c. Attach a hose to vertical purge valve in boiler system supply piping up stream from the full port ball valve.
 

(NOTE - Terminate hose in five gallon bucket at a suitable floor drain or outdoor area).
  - d. Starting with one zone at a time, open zone valve or shut-off valve in boiler supply and return piping.

- e. Open purge valve.
- f. Open shut-off valve in cold water supply piping located between the air scoop and expansion tank.
- g. Allow water to overflow from bucket until discharge from hose is bubble free for 30 seconds.
- h. When zone valve is completely purged of air, close zone valve or shut-off valve. Open zone valve to the next zone to be purged. Repeat this step until all zones have been purged. At completion, open all zone valves.
- i. Close purge valve, continue filling the system until the pressure gauge reads 12 psi. Close shut-off valve in cold water supply piping.

## WARNING

The maximum operating pressure of this boiler is posted on the ASME Data Label located on the top of the boiler. Never exceed this pressure. Do not plug relief valve.

**NOTICE:** If make-up water line is equipped with pressure reducing valve, system will automatically fill to 12 psi. Follow fill valve manufacturer's instructions.

- j. Open full port ball valve in boiler system piping.
  - k. Remove hose from purge valve.
  - l. Confirm that the boiler and system have no water leaks.
  - m. It may be necessary to clean the air vent assembly after a few days of operation.
- ### C. CHECK CONTROLS, WIRING AND BURNER to be sure that all connections are tight and burner is rigid, that all electrical connections have been completed and fuses installed, and that oil tank is filled and oil lines have been tested.

## 10 System Start-Up *(continued)*

### D. **ADJUST CONTROL SETTINGS** with burner service switch turned “ON”.

1. SET ROOM THERMOSTAT about 10°F below room temperature.
2. PRESS RED RESET BUTTON on burner primary control, hold for ten (10) seconds and release to reset the control.
3. CHECKOUT  
Put the system into operation and observe at least one complete cycle to make sure that the controller operates properly. See Troubleshooting Section to use LED to assist in determining system operation.

### E. **CHECK / ADJUST OIL BURNER BEFORE STARTING.**

#### Natural Vent Applications:

#### 1. Beckett AFG Burners

- a. Verify nozzle size, head size, gun setting, and positioning of electrodes. This information is shown in Figure 32, and Beckett AFG Burner Specifications, Table 9.
- b. Inspect Beckett head setting on left side of burner housing by insuring the blue line MD(V1) or the line on the label MB(L1) are aligned, readjust if necessary. Refer to Figure 32 and Table 9 at the end of this manual.
- c. Check burner air band and air shutter settings. Readjust if necessary, see Beckett AFG Burner Specifications, Table 9 at the end of this manual.
- d. OPEN ALL SHUT-OFF VALVES in the oil supply line to the burner.
- e. ATTACH A PLASTIC HOSE TO FUEL PUMP VENT/BLEED FITTING and place the other hose end into an empty container to catch the oil.
- f. SLIGHTLY OPEN FLAME OBSERVATION PORT COVER on burner swing door, enough to insert draft gauge probe later.

#### Direct Vent Applications:

#### 2. Beckett NX Burners

- a. Verify nozzle size, gun setting and positioning of electrodes. See Figures 34 and 36 and Beckett NX Burner Specifications, Table 10 at the end of this manual.
- b. Remove burner cover by loosening the four thumb screws and set aside.

- c. Disconnect the copper oil connector tube from nozzle line.
- d. Loosen the two screws securing igniter-retaining clips and rotate both clips to release the igniter baseplate. The igniter should pop-up and would be supported by the prop spring.
- e. Loosen the two screws securing the rear door, then swing to the right and down.
- f. Loosen splined nut.
- g. Lift up the igniter baseplate and simultaneously remove nozzle line assembly from burner by drawing it straight back out the rear door opening. Be careful not to damage the electrodes or insulators while handling.
- h. Check electrodes to comply with dimensions shown in Figure 33. For adjustment, loosen the electrode clamp screw and slide/rotate electrodes as needed. Securely re-tighten the clamp screw when finished.
- i. Check retention head alignment. Cad cell sighting holes in the throttle cup and retention head must line up, so the cad cell can see the flame. Make sure that, the “stamped key” in the retention head collar lines up with the “keyway” in the nozzle adapter, when mounting the retention head. See Figure 34.
- j. To re-install the nozzle line assembly, reverse procedure outlined in steps f thru b.
- k. Upon reinstallation of the nozzle line assembly, check that head/air plate setting number pointer lines up with a number on the scale, which matches a value shown in Table 10 for a particular boiler/burner model.  
  
The zero calibration has been factory set; the upper left acorn nut locks retention head at “0” position. If the zero calibration has to be reset, follow the adjustment procedure, outlined at “Prepare Burner & Site” section of Beckett Model NX Oil Burner Instruction Manual, Form Number 610BNX. Make sure the retention head is securely against the stops in the retention ring, when the adjustment plate pointer is at “0”.
- l. The rear door must be kept tightly closed upon reinstallation of the nozzle line assembly.



# 10 System Start-Up *(continued)*

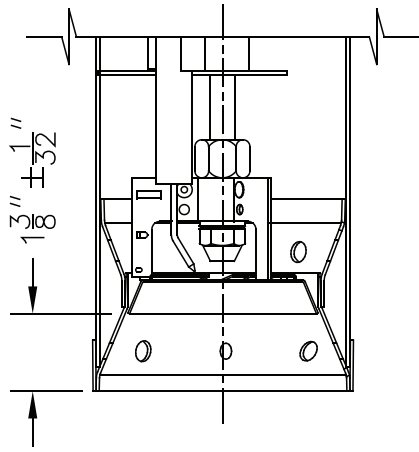

L1 HEAD

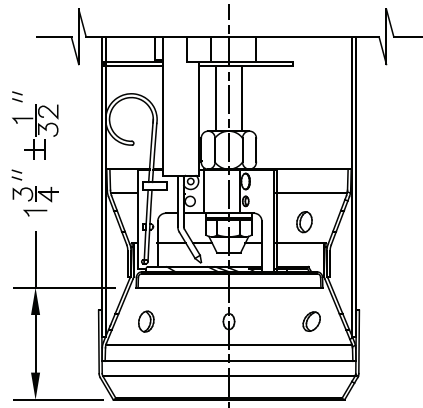

V1 HEAD

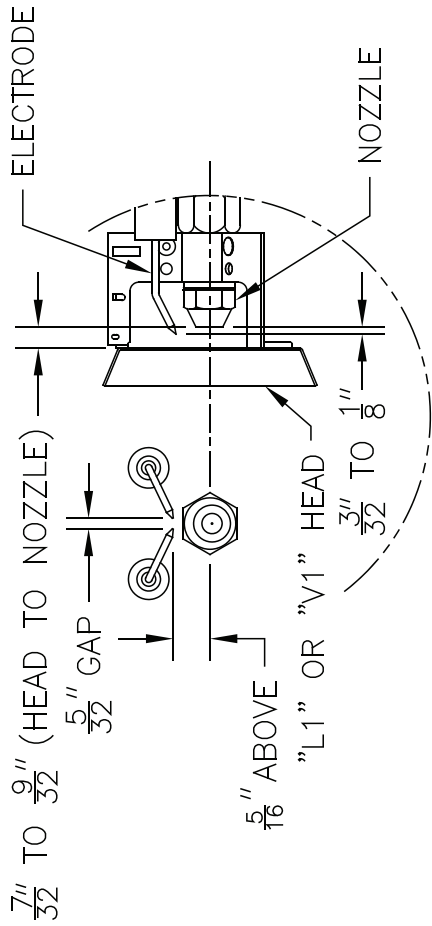

ELECTRODE ADJUSTMENT  
"L1" OR "V1" HEAD

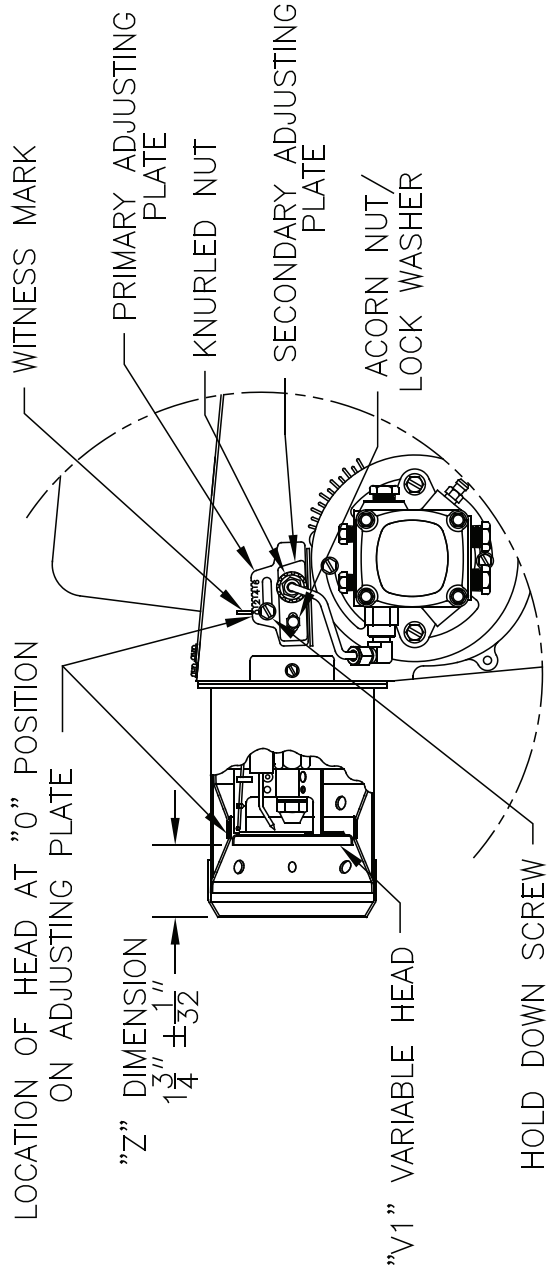

HEAD SETTING (AT "0")  
"V1" HEAD

Figure 32: "L1" and "V1" Head Electrode Positioning and Gun Setting (Beckett AFG)

# 10 System Start-Up *(continued)*

- m. Loosening the splined nut and lower acorn nut, and, turning the adjustment screw, either forward or, rearwards, will adjust the head/air plate. DO NOT LOOSEN UPPER LEFT ACORN NUT, which locks zero head/air setting. See Figure 35.
- n. OPEN ALL SHUT-OFF VALVES in the oil supply line to the burner.
- o. ATTACH A PLASTIC HOSE TO FUEL PUMP VENT/BLEED FITTING and place the other hose end into an empty container to catch the oil.
- p. SLIGHTLY OPEN FLAME OBSERVATION PORT COVER on burner swing door, enough to insert draft gauge probe later.

## **⚠ WARNING**

Very hot flue gases come out of flame observation port cover hole when boiler is operated with port cover open. Always wear proper eye protection.

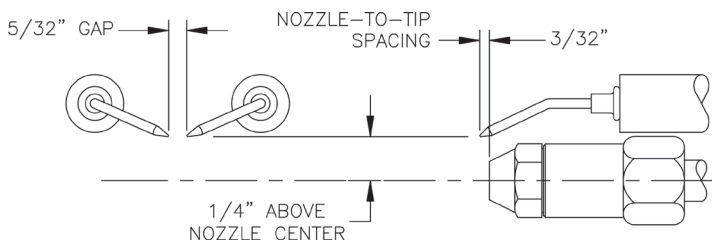

**Figure 33: Electrode Tip Gap and Spacing**

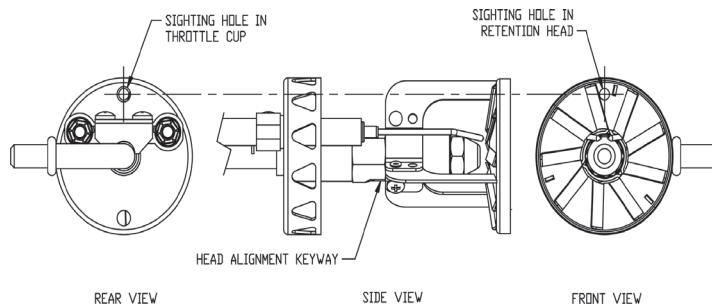

**Figure 34: Retention Head/Throttle Cup Alignment**

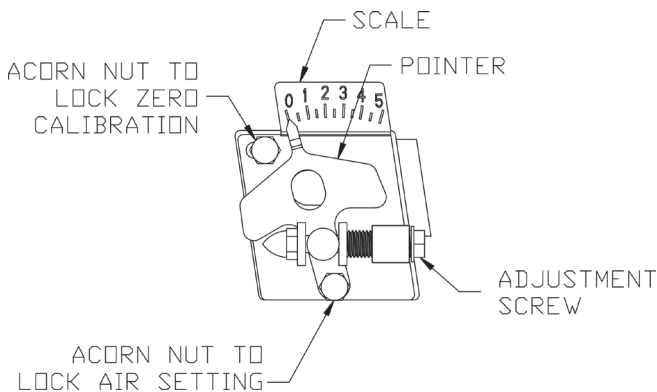

**Figure 35: Head/Air Adjustment Plate Assembly**

## **F. START OIL BURNER.**

1. Open vent fitting on fuel pump.
2. PRESS RED RESET BUTTON on primary control, hold for ten (10) seconds and release to reset primary control.
3. TURN 'ON' BURNER service switch and allow burner to run until oil flows from vent fitting in a SOLID stream without air bubbles for approximately 10 seconds.

**NOTE:** For Primary Control "Pump Priming Cycle" details, see Paragraph I, No. 2., Step a., Item *ii*.

4. Close vent fitting and burner flame should start immediately after prepurge is completed. Prepurge prevents burner flame until 15 seconds has elapsed after initial power is applied to burner. During prepurge the motor and igniter will operate but the oil valve will remain closed. Refer to Oil Primary Control Instructions for more details.
5. Adjust oil pressure.
  - a. When checking a fuel unit's operating pressure, a reliable pressure gauge may be installed in either the bleeder port or the nozzle port. Refer to Figure 36.
  - b. Locate oil pressure adjusting screw and turn screw to obtain proper pump pressure, refer to Tables 9 and 10 at the end of this manual.

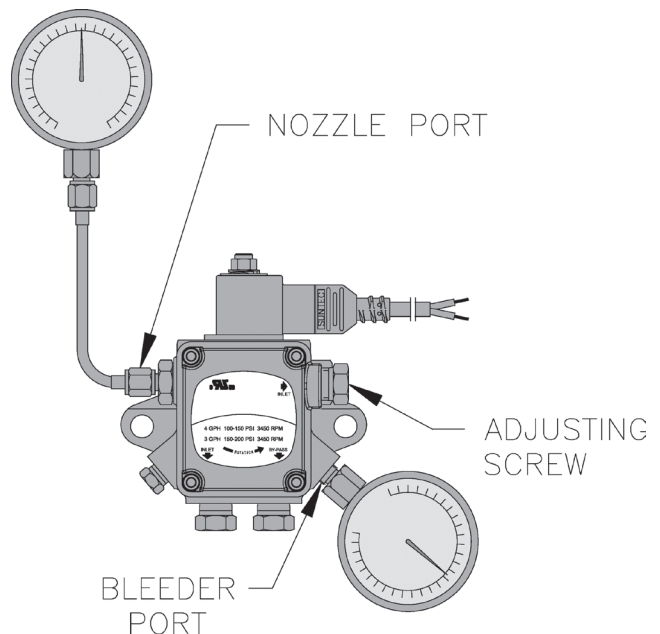

**Figure 36: Adjusting Fuel Pump Pressure**

## 10 System Start-Up *(continued)*

- c. To check the cut-off pressure, deadhead a reliable pressure gauge onto the copper connector tube attached to the nozzle port. Run the burner for a short period of time. Shut the burner off. The pressure should drop and hold.
- d. Turn "OFF" the burner. Remove the pressure gauge and install port/bleeder plug and/or reconnect the nozzle port line and tighten. Start the burner again.

### G. ADJUST OIL BURNER WHILE OPERATING. (flame present)

1. ADJUST DRAFT REGULATOR for a draft of zero inches (water gauge) in the canopy (see Figure 15) after chimney has reached operating temperature and while burner is running (at least five minutes). See Table 9 at the end of this manual for additional details.
2. READJUST THE AIR DAMPER SETTING (Air Band/Air Shutter) on burner for a light orange colored flame while the draft in the canopy is zero inches water column ("w.c."). Use a smoke tester and adjust air for minimum smoke (not to exceed #1) with a minimum of excess air. Make final check using suitable instrumentation to obtain a CO<sub>2</sub> of 11.5 to 13.0% with draft of zero inches water column ("w.c.") (water gauge) in canopy. These settings will assure a safe and efficient operating condition. If the flame appears stringy instead of a solid fire, try another nozzle of the same type. Flame should be solid and compact. After all adjustments are made recheck for a draft of zero inches water column ("w.c.") in the canopy. Replace plug at completion.

See Table 9 (at the end of this manual) for details regarding the overfire pressure when baffles are both installed and removed.

**NOTE:** Paragraph G, Step 1 **MUST BE** repeated every time the Air Damper Setting is readjusted.

3. ONLY READJUST THE HEAD SETTING, if necessary.

#### **Beckett AFG Burners**

- a. FORCEOL084-E through FORCEOL140-E Beckett MB(L1 & L2) Head burners have a fixed head which are non-adjustable.
- b. FORCEOL182-E:  
Beckett MD(V1) (variable) Head burners have the ability to control air by moving the head. It might be necessary to move the head forward or back one position at a time

to optimize the smoke and CO<sub>2</sub> readings. See Figure 32.

#### **Beckett NX Burners**

Move the Head/Air Setting forward or back one position at a time to optimize the smoke and CO<sub>2</sub> readings. See Figure 35.

**NOTE:** Step outlined in Paragraph G, Steps 1 and 2 above **MUST BE** repeated every time the Head or Air Damper Setting is readjusted.

### **WARNING**

DO NOT loosen or remove any oil line fittings while burner is operating.

#### 4. FLAME FAILURE

The FORCE OIL boiler controls operate the burner automatically. If for unknown reasons the burner ceases to fire and the reset button on the primary control has tripped, the burner has experienced ignition failure. Refer to Oil Primary Control features, Paragraph I, Step 2 of this section and Section XIV, Troubleshooting, Paragraph B. If the failure re-occurs, call your heating contractor immediately before pressing the reset button.

### **WARNING**

DO NOT attempt to start the burner when excess oil has accumulated, when the boiler is full of vapor, or when the combustion chamber is very hot.

#### 5. CAD CELL LOCATION AND SERVICE

The burner is supplied with a cadmium sulfide flame detector mounted at the factory, mounted on the bottom of the electronic ignitor. See Figure 37. To service cad cell or to replace the plug in portion, swing open the ignitor. After service is complete, be sure to fasten down the ignitor.

### H. CHECK FOR CLEAN CUT OFF OF BURNER.

1. AIR IN THE OIL LINE between fuel unit and nozzle will compress when burner is on and will expand when burner stops, causing oil to squirt from nozzle at low pressure as burner slows down and causing nozzle to drip after burner stops. Usually cycling the burner operation about 5 to 10 times will rid oil line of this air.
2. IF NOZZLE CONTINUES TO DRIP, repeat Paragraph H, Step 1 above. If this does not stop the dripping, remove cut-off valve and seat, and wipe both with a clean cloth until

## 10 System Start-Up *(continued)*

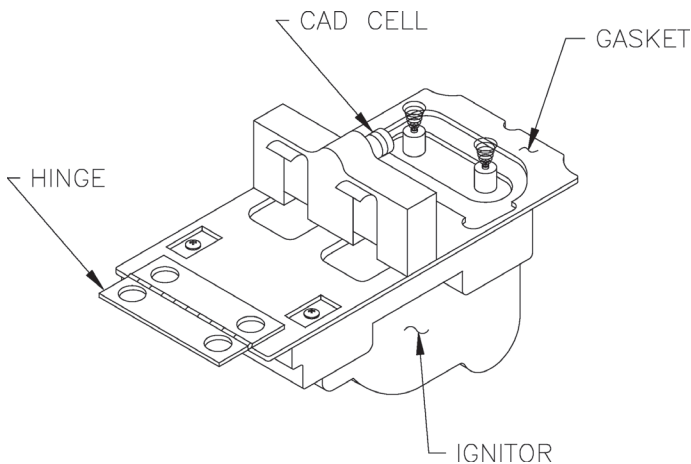

**Figure 37: Cad Cell Location**

clean, then replace and readjust oil pressure. If dripping or after burn persist replace fuel pump.

### I. TEST CONTROLS.

1. Check thermostat operation. Raise and lower thermostat setting as required to start and stop burner.

#### **⚠ WARNING**

Before installation of the boiler is considered complete, the operation of all boiler controls must be checked, particularly the primary control and high limit control.

### 2. VERIFY OIL PRIMARY CONTROL

**FEATURES** using procedures outlined in Instructions furnished with control or instructions as follows:

- a. **GeniSys 7505 Control Features**, see Figure 38.
  - i. The GeniSys 7505 is a microprocessor-based control. The indicator light provides diagnostic information for lockout, recycling and cad cell status. There is a manual reset button to exit the Lockout Mode.
  - ii. Pump Priming Cycle: To facilitate purging air from the oil lines and filters, the 7505 can be placed in a purge routine by:
    - After the burner starts, press and hold the reset button for 15 seconds until the yellow light turns on. This indicates that the button has been held long enough.
    - Release the reset button. The yellow light will turn off and the burner will start up again.

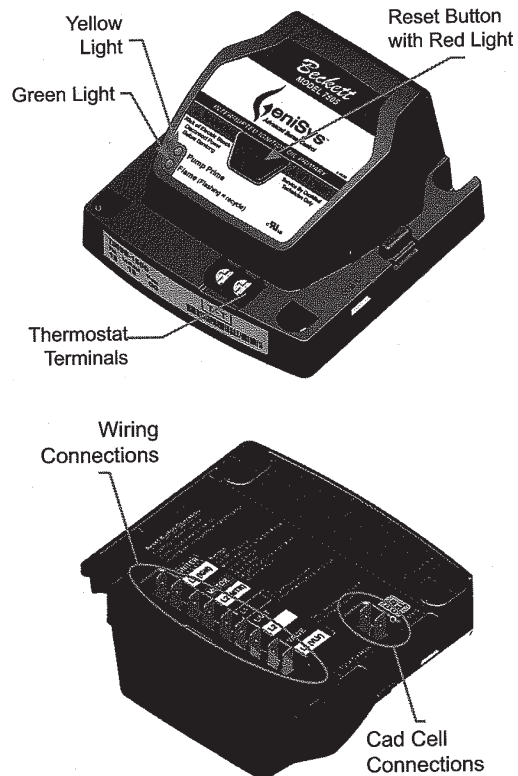

**Figure 38: GeniSys 7505 Oil Primary Terminals, LED's and Reset Button**

- At burner start up, click the reset button while the igniter is still on. This will transition the control to a dedicated Pump Prime mode, during which the motor, igniter, and valve are powered for four (4) minutes. The yellow light will be on.
  - At the end of four (4) minutes, the yellow light will turn off and the control will automatically return to standby mode.
- iii. Limited Recycle: This feature limits the number of recycle trials (for each call for heat) to a maximum of three trials. If the flame is lost three times and does not successfully satisfy a call for heat, the 7505 locks out.
  - iv. Limited Reset (Restricted Mode): In order to limit the accumulation of unburned oil in the combustion area, the control can only be reset three times. The reset count returns to zero each time a call for heat is successfully completed.
  - v. T-T Jumper: Select models have pre-installed T-T jumper. **DO NOT** remove jumper.

## 10 System Start-Up *(continued)*

**NOTE: DO NOT** remove "T-T" jumper unless wiring diagram indicates a direct connection from thermostat and/or tankless heater HydroStat 3250 control to the oil burner primary control's "T-T" terminal. Refer to appropriate wiring diagram, see Figures 27 and 28.

- vi. Diagnostic LED: The indicator light on oil primary control provides lockout, recycle and cad cell indications as follows:
- Flashing at 1 Hz (½ second on, ½ second off): system is locked out or in Restricted Mode.
  - Flashing at ¼ Hz (2 seconds on, 2 seconds off): control is in Recycle Mode.
  - On: cad cell is sensing flame.
  - Off: cad cell is not sensing flame.
- vii. Cad Cell Resistance Check: For proper operation it is important that the cad cell resistance is below 1600 ohms. During a normal call for heat, the cad cell leads can be unplugged from the control and the resistance measured with a meter in the conventional way. Conduct these tests with flame present, see chart below.

Flame Detection Range
Normal (0 - 1600 ohms)
Limited (1600 ohms to lockout)

### 3. CHECK OIL PRIMARY CONTROL

#### CAUTION

Due to the potential hazard of line voltage, only a trained, experienced service technician should perform the following safety checks.

This control contains no field-serviceable parts. **DO NOT** attempt to take it apart. Replace entire control if operation is not as described.

- a. Preliminary Steps
- Check wiring connections and power supply.
  - Make sure power is on to the controls.
  - Make sure limit control is closed.
  - Check contacts between ignitor and the electrodes.
  - Check the oil pump pressure.
  - Check the piping to the oil tank.
  - Check the oil nozzle, oil supply and oil filter.

#### b. Check Safety Features

Safe Start:

- Place a jumper across cad cell terminals.
- Follow procedure to turn on burner. Burner must not start, indicator light turns on and control remains in Idle Mode.
- Remove jumper.

#### c. Simulate Ignition or Flame Failure:

- Follow procedure to turn on burner.
- Check cad cell resistance. If resistance is below 1600 OHMS and burner runs beyond safety cut-out time, cad cell is good.
- If safety switch shuts down burner and resistance is above 1600 OHMS, open line switch to boiler. Access cad cell under ignitor, clean face of cad cell and see that cell is securely in socket. Check gasket around perimeter of ignitor lid for proper seal. If gasket is missing or damaged, replace gasket. Room light can effect cad cell resistance. Reset safety switch.
- Close line switch to boiler. If burner starts and runs beyond safety switch cut-off time, cell is good. If not, install new cell.
- Close hand valve in oil supply line.
- Failure occurs, device enters Recycle Mode.
- Device tries to restart system after approximately 60 seconds.
- After third Recycle Mode trial, safety switch locks out within safety switch timing indicated on label and control enters Restricted Mode. Ignition and motor stop and oil valves closes.

- d. Power Failure Check: After Flame is established, turn the power off to the control/burner. The burner should shut down safely. When power is restored a normal ignition sequence should be started.

#### WARNING

Cad Cell Jumper must be removed after this check.

### 4. CHECK HIGH LIMIT

- a. Adjust system thermostat(s) to highest setting.
- b. Allow burner to run until boiler water temperature exceeds high limit setting. The burner should shut down and circulators continue running.

## 10 System Start-Up *(continued)*

- c. Allow the temperature to drop below control setting. The burner must restart.
  - d. Boiler installation is not considered complete until this check has been made.
5. CHECK LOW WATER CUT-OFF
- a. Press and hold the test / settings button for 5 seconds.
  - b. The red low water light should illuminate and the burner circuit (B1 & B2) should de-energize.
6. CHECK AFTERMARKET LOW WATER CUT-OFF CONTROL, if required on this boiler application. See Appendix "B" at the rear of this manual for 'How to Test'.

**J. IF CONTROLS MEET REQUIREMENT** outlined in Paragraph I.

Allow boiler to operate for approximately 30 minutes, confirm the boiler and system have no leaks.

**K. IF CONTROLS DO NOT MEET REQUIREMENTS** outlined in Paragraphs I-1 thru I-5, replace control and repeat checkout procedures.

# 11 Operating

Refer to the HydroStat 3250 Installation Instructions and Operating Manual included with these instructions.

## IMPORTANT

This boiler is equipped with a feature that saves energy by reducing the boiler water temperature as the heating load decreases. This feature is equipped with an override which is provided primarily to permit the use of an external energy management system that serves the same function. THIS OVERRIDE MUST NOT BE USED UNLESS AT LEAST ONE OF THE FOLLOWING CONDITIONS IS TRUE:

- An external energy management system is installed that reduces the boiler water temperature as the heating load decreases.
- This boiler is not used for any space heating.
- This boiler is part of a modular or multiple boiler system having a total input of 300,000 BTU/hr or greater.
- This boiler is equipped with a tankless coil.

## 12 Service and Maintenance Instructions

### A. WATER BOILERS:

#### 1. Filling of boiler and system.

GENERAL — In a hot water heating system, the boiler and entire system (other than the expansion tank) must be full of water for satisfactory operation. Water should be added to the system until the boiler pressure gauge registers 12 psi. To insure that the system is full, water should come out of all air vents when opened.

#### 2. BOILING OUT OF BOILER AND SYSTEM. The oil and grease which accumulate in a new hot water boiler can be washed out in the following manner:

- a. Ideally, shut off valves have been installed between the boiler return manifold and the rest of the system, to minimize the amount of system draining.
- b. Drain the boiler to a level below the relief valve tapping.

### DANGER

Assure that the boiler is at zero pressure before removing the relief valve. Open the safety valve to relieve all internal pressure prior to proceeding. Safety valve discharge piping must be piped such that the potential for burns is eliminated.

- c. Remove relief valve using extreme care to avoid damaging it.
- d. Add an appropriate amount of recommended boil out compound.
- e. Replace relief valve.
- f. Fill the entire system with water.
- g. Start firing the boiler.
- h. Circulate the water through the entire system.
- i. Vent the system, including the radiation.
- j. Allow boiler water to reach operating temperature, if possible.
- k. Continue to circulate the water for a few hours.
- l. Stop firing the boiler.
- m. Drain the system in a manner and to a location that hot water can be discharged with safety.

- n. Remove plugs from all available returns and wash the water side of the boiler as thoroughly as possible, using a high-pressure water stream.

- o. Refill the system with fresh water.

#### 3. Add appropriate boiler water treatment compounds as recommended by your qualified water treatment company.

#### 4. Make pH or Alkalinity Test.

After boiler and system have been cleaned and refilled as previously described, test the pH of the water in the system. This can easily be done by drawing a small sample of boiler water and testing with hydrion paper which is used in the same manner as litmus paper, except it gives specific readings. A color chart on the side of the small hydrion dispenser gives the reading pH. Hydrion paper is inexpensive and obtainable from any chemical supply house or through your local druggist. The pH should be higher than 7 but lower than 11. Add some of the washout chemical (caustic soda), if necessary, to bring the pH within the specified range. With this lower level of protection, care must be exercised to eliminate all of the free oxygen in the system.

#### 5. Boiler is now ready to be put into service.

### B. EXCESSIVE MAKE-UP WATER

A leaky system will increase the volume of make-up water supplied to the boiler, which can significantly shorten the life of the boiler. Entrained in make-up water are dissolved minerals, salts and oxygen. When the fresh, cool make-up water is heated in the boiler, the minerals fall out as sediment, the salts coat the inside of the boiler, and the oxygen escapes as a gas. The accumulation of sediment eventually isolates the water from contacting the cast iron. When this happens the cast iron in that area gets extremely hot and eventually cracks. The presence of free oxygen or chloride salts in the boiler creates a corrosive atmosphere which, if the concentration becomes high enough, can corrode the cast iron through from the inside. More make-up water and higher concentrations of contaminants damage the boiler sooner. **Our warranty does not cover corrosion and sediment-related damage.**

Clearly it is in everyone's best interest to prevent this type of failure. You can do your part by ensuring that your system is leak-free, keeping leakage to less than 2 percent of the boiler water volume each month. Refer to chart below.



## 12 Service and Maintenance Instructions *(continued)*

### IMPORTANT

IF, DURING NORMAL OPERATION, IT IS NECESSARY TO ADD MORE WATER THAN INDICATED BELOW, CONSULT A QUALIFIED SERVICE TECHNICIAN TO CHECK YOUR SYSTEM FOR LEAKS.

Boiler Model	Gallons Per Month	Gallons Per Year
FORCEOL084-E	0.20	2
FORCEOL115-E	0.20	2
FORCEOL140-E	0.25	3
FORCEOL182-E	0.30	4

### C. ATTENTION TO BOILER WHILE NOT IN OPERATION

**NOTICE:** If boiler is not used during winter time, it must be fully drained to prevent freeze damage.

1. Prevent Freeze Damage  
**Important:** If boiler is **NOT** used during winter time, it must be fully drained to prevent freeze damage.
2. Spray inside surfaces with light lubricating or crankcase oil using gun with extended stem so as to reach all corners.
3. Always keep the manual fuel supply valve shut off if the burner is shut down for an extended period of time.
4. To recondition the heating system in the fall season after a prolonged shut down, follow the instructions outlined in Section X, System Start-Up, Paragraphs A through K.

### WARNING

This boiler contains controls which may cause the boiler to shut down and not restart without service. If damage due to frozen pipes is a possibility, the heating system should not be left unattended in cold weather; or appropriate safeguards and alarms should be installed on the heating system to prevent damage if the boiler is inoperative.

# 13 Boiler Cleaning

## WARNING

This boiler contains controls which may cause the boiler to shut down and not restart without service. If damage due to frozen pipes is a possibility, the heating system should not be left unattended in cold weather; or appropriate safeguards and alarms should be installed on the heating system to prevent damage if the boiler is inoperative.

### A. CLEAN THE FLUEWAYS (See Figure 39).

1. For access to the combustion chamber remove the two (2) 3/8" - 16 cap screws. If boiler is equipped with flexible fuel line(s), swing door open.
2. Remove the two smoke box clean-out covers from the rear smoke box by removing the four 5/16"-18 hex head bolts. It is NOT necessary to remove the vent connector from the smoke box to clean boiler.  
If necessary, remove the vent connector if there is evidence of heavy soot accumulation in the boiler or to inspect base of chimney for condensate or accumulation of debris.
3. Remove the baffles (if installed) from the flue passages. Refer to Section III, Paragraph F for Baffle Installation.
4. Clean the 3<sup>rd</sup> Pass – Insert a 2" dia. x 42" long wire or fiber bristle brush into each of the two 3<sup>rd</sup> passes. Using long strokes push the brush all the way through the boiler until the brush has exited the smoke box opening. Pull the brush all the way forward until it has exited the front of the boiler. Continue this operation for the entire height of the flue way until clean. Repeat the operation for the other 3<sup>rd</sup> pass flue way.
5. Clean the 2<sup>nd</sup> Pass - Insert a 2" dia. x 42" long wire or fiber bristle brush into each of the two 2<sup>nd</sup> passes. Using long strokes push the brush all the way through the boiler until the brush hits the back wall of the reversing chamber. Pull the brush all the way forward until it has exited the front of the boiler. Continue this operation for the entire height of the flue way until clean. Repeat the operation for the other 2<sup>nd</sup> pass flue way.
6. Vacuum the loose debris in the bottom of the combustion chamber and smoke box.

### B. CLEAN THE COMBUSTION CHAMBER

Use a wire or fiber bristle brush to clean the surfaces of the combustion chamber. Vacuum all of the loose debris in the bottom of the combustion chamber.

- ### C. AFTER CLEANING, vacuum all remaining debris as necessary. Inspect burner swing door insulation, and rope gasket for signs of damage. If damaged, replace as needed.

### D. REASSEMBLE BOILER.

## CAUTION

Do not start the burner unless the burner swing door and canopy cover plates are secured in place.

1. Insert the baffles (if originally installed) into the correct flue way. Refer to Section III, Paragraph F for Baffle Installation.
2. Attach the smoke box clean-out covers onto the rear of the boiler. Verify that the rope gasket is in good working order before assembly. Replace rope gasket if necessary. Use the 3/8" hardware originally removed. Do not over tighten. They should be snug but not bottomed out.

**NOTICE:** When securing burner swing door make sure door is drawn-in equally on both sides.

Tighten swing door hardware to provide adequate seal to rope gasket around perimeter of door.

Use an alternating tightening method from right side to left side cap screw to pull door tight equally.

**NOTICE:** Do not overtighten. The rope gasket will provide sufficient seal when the door is snugged into place.

# 13 Boiler Cleaning *(continued)*

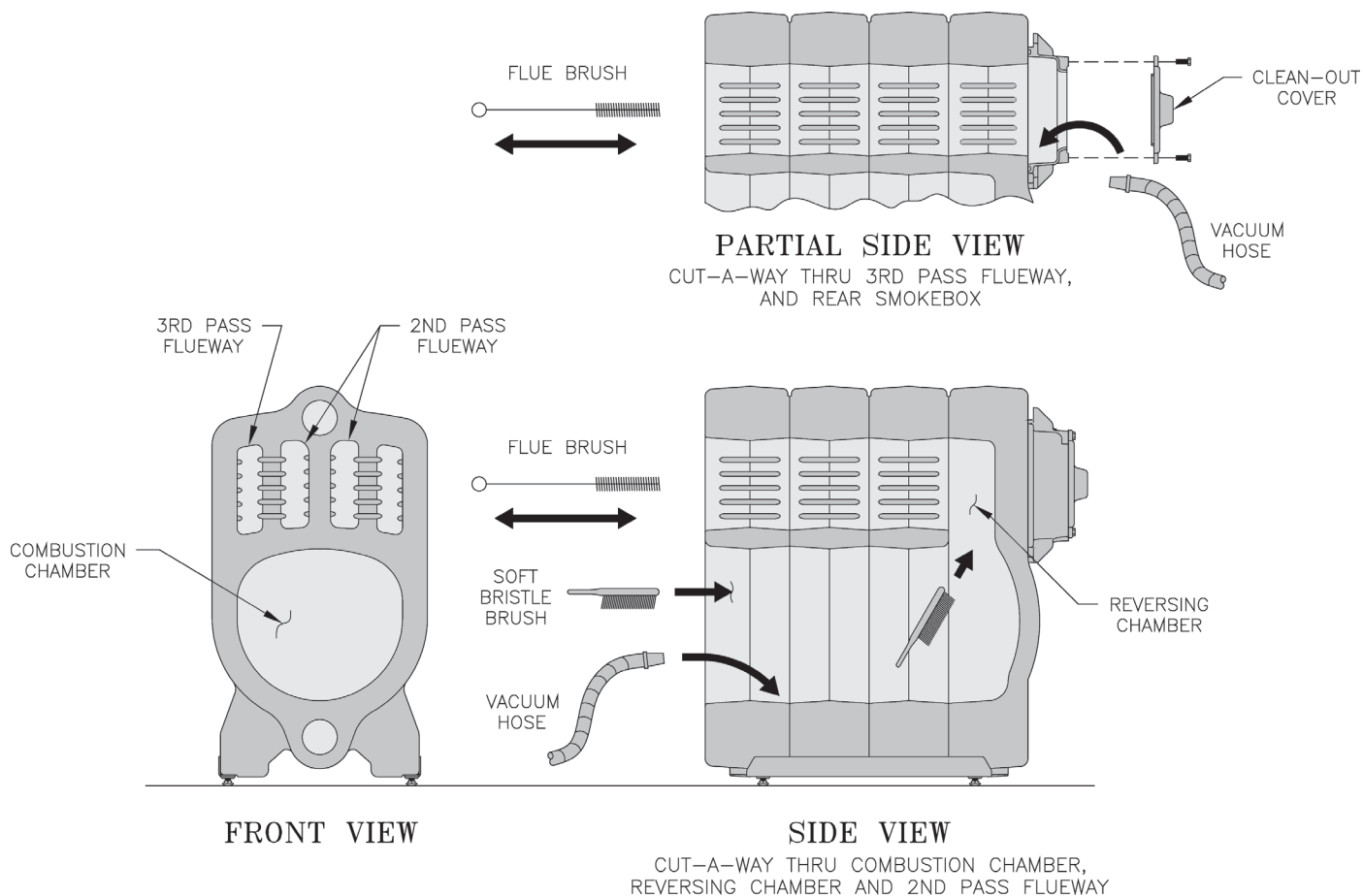

**Figure 39: Cleaning of Boiler Flueways**

**⚠ WARNING**

The boiler must be connected to an approved chimney in good condition. Serious property damage could result if the boiler is connected to a dirty or inadequate chimney. The interior of the chimney flue must be inspected and cleaned before the start of the heating season and should be inspected periodically throughout the heating season for any obstructions. A clean and unobstructed chimney flue is necessary to allow noxious fumes that could cause injury or loss of life to vent safely and will contribute toward maintaining the boiler's efficiency.

## 13 Boiler Cleaning *(continued)*

### Important Product Safety Information: Refractory Ceramic Fiber Product

#### WARNING

**Some boiler components use materials that contain refractory ceramic fibers (RCF). RCF has been classified as a possible human carcinogen. When exposed to elevated temperatures, RCF may change into crystalline silica, a known carcinogen. When disturbed as a result of servicing or repair, these substances become airborne and, if inhaled, may be hazardous to your health. Avoid breathing RCF particulates and dust.**

#### Precautionary Measures:

- Do not handle RCF parts or attempt any service or repair work involving RCF without wearing the following protective gear:
  1. A properly fitting National Institute for Occupational Safety and Health (NIOSH)-certified air-purifying respirator with a filter efficiency of at least 95%. Respirator should also include a full facepiece when handling used RCF. Other types of respirators may be required depending on site conditions. Current NIOSH recommendations may be found on the NIOSH website <http://www.cdc.gov/niosh/homepage.html>. NIOSH-approved manufacturers, respirators and associated user instructions are listed on the NIOSH website.
  2. Long sleeved, loose fitting clothing that is sufficiently tight around potential entry points for RCF dust.
  3. Gloves.
  4. Eye protection, such as goggles, safety glasses with side shields, or full facepiece.
- Take steps to assure adequate ventilation.
- Handle RCF carefully to minimize airborne dust. Use hand tools whenever possible.
- Dampen used RCF with light water spray prior to removal to prevent airborne dust.
- Do not use compressed air or dry sweeping for clean-up. Frequently clean work area with a vacuum or by wet sweeping to minimize debris accumulation.
- Vacuum work clothes before leaving work area. Wash work clothes separately from other laundry and rinse washing machine after use to avoid contaminating other clothes.
- Wash all exposed body areas gently with soap and water after contact.
- Discard used RCF components by sealing in an airtight plastic bag or container. Refer to local, regional, state or provincial regulations to identify applicable disposal requirements.

#### First Aid Procedures:

- Eye contact: Flush with water for at least 15 minutes. Do not rub eyes. Seek immediate medical attention if irritation persists.
- Skin contact: Wash affected area gently with soap and water. Do not rub or scratch affected skin. Seek immediate medical attention if irritation persists.
- Nose and throat contact: If these become irritated, leave the area and move to a location with clean fresh air. Drink water and blow nose. Seek immediate medical attention if symptoms persist.

# 14 Troubleshooting

## A. COMBUSTION

1. **NOZZLES** — Although the nozzle is a relatively inexpensive device, its function is critical to the successful operation of the oil burner. The selection of the nozzle supplied with the FORCE OIL boiler is the result of extensive testing to obtain the best flame shape and efficient combustion. Other brands of the same spray angle and spray pattern may be used but may not perform at the expected level of CO<sub>2</sub> and smoke. Nozzles are delicate and should be protected from dirt and abuse. Nozzles are mass-produced and can vary from sample to sample. For all of those reasons a spare nozzle is a desirable item for a serviceman to have.
2. **FUEL LEAKS** — Any fuel leak between the pump and the nozzle will be detrimental to good combustion results. Look for wet surfaces in the air tube, under the ignitor, and around the air inlet. Any such leaks should be repaired as they may cause erratic burning of the fuel and in the extreme case may become a fire hazard.
3. **SUCTION LINE LEAKS** — Any such leaks should be repaired, as they may cause erratic burning of the fuel and in extreme cases may become a fire hazard. Whatever it takes, **The Oil Must Be Free of Air**. This can be a tough problem, but it must be resolved. Try bleeding the pump through a clear tube. There must be no froth visible. There are various test kits available to enable you to look at the oil through clear tubing adapted to the supply line at the pump fitting. Air eliminators are on the market that have potential. Also, electronic sight glasses are being used with good success. At times, new tubing must be run to the tank or new fittings put on. Just make sure you get the air out before you leave.

Any air leaks in the fuel line will cause an unstable flame and may cause delayed ignition noises. Use only flare fittings in the fuel lines.
4. **GASKET LEAKS** — If 11.5 to 12.5% CO<sub>2</sub> with a #1 smoke cannot be obtained in the breeching, look for air leaks around the burner mounting gasket, observation door, and canopy gasket. Such air leaks will cause a lower CO<sub>2</sub> reading in the breeching. The smaller the firing rate the greater effect an air leak can have on CO<sub>2</sub> readings.
5. **DIRT** — A fuel filter is a good investment. Accidental accumulation of dirt in the fuel system can clog the nozzle or nozzle strainer and produce a poor spray pattern from the nozzle. The smaller the firing rate, the smaller the slots become in the nozzle and the more prone to plugging it becomes with the same amount of dirt.
6. **WATER** — Water in the fuel in large amounts will stall the fuel pump. Water in the fuel in smaller amounts will cause excessive wear on the pump, but more importantly water doesn't burn. It chills the flame and causes smoke and unburned fuel to pass out of the combustion chamber and clog the flueways of the boiler.
7. **COLD OIL** — If the oil temperature approaching the fuel pump is 40°F or lower, poor combustion or delayed ignition may result. Cold oil is harder to atomize at the nozzle. Thus, the spray droplets get larger and the flame shape gets longer. An outside fuel tank that is above grade or has fuel lines in a shallow bury is a good candidate for cold oil. The best solution is to locate the tank near the boiler in the basement utility room or bury the tank and lines deep enough to keep the oil above 40°F. Check environmental issues with local authorities having jurisdiction.
8. **FLAME SHAPE** — Looking into the combustion chamber through the observation port, the flame should appear straight with no sparklers rolling up toward the crown of the chamber. If the flame drags to the right or left, sends sparklers upward or makes wet spots on the target wall, the nozzle should be replaced. If the condition persists look for fuel leaks, air leaks, water or dirt in the fuel as described above.
9. **START-UP NOISE** — Late ignition is the cause of start-up noises. If it occurs recheck for electrode settings, flame shape, air or water in the fuel lines.
10. **SHUT DOWN NOISE** — If the flame runs out of air before it runs out of fuel, an after burn with noise may occur. That may be the result of a faulty cut-off valve in the fuel pump, or it may be air trapped in the nozzle line. It may take several firing cycles for that air to be fully vented through the nozzle. Water in the fuel or poor flame shape can also cause shut down noises.

## 14 Troubleshooting *(continued)*

**NOTICE:** CHECK TEST PROCEDURE. A very good test for isolating fuel side problems is to disconnect the fuel system and with a 24" length of tubing, fire out of an auxiliary five gallon pail of clean, fresh, warm #2 oil from another source. If the burner runs successfully when drawing out of the auxiliary pail then the problem is isolated to the fuel or fuel lines being used on the jobsite.

### B. OIL PRIMARY CONTROL (Oil Primary)

1. Burner (Oil Primary) will not come on.
  - a. No power to Oil Primary.
  - b. Oil Primary is in lockout or restricted mode. Press reset button for one (1) second to exit lockout. If control has recycled three times within the same call for heat, it will enter into restricted mode. To reset from restricted mode, refer to Section X, Paragraph I, Step 2 for details.
  - c. CAD cell seeing light.
  - d. CAD assembly defective.
  - e. Control motor relay is stuck closed (see note below).
2. Burner (control) will light, then shut down after a short time, then restart after one (1) minute.
  - a. CAD cell is defective.
  - b. Air leaking into oil line causing flame out.
  - c. Defective nozzle causing flame to be erratic.
  - d. Excessive airflow or draft causing flame to leave burner head.

- e. Excessive back pressure causing flame to be erratic.
3. Control locks out after Trial For Ignition (TFI).
    - a. No oil to burner.
    - b. Shorted electrodes.
    - c. Nozzle clogged.
    - d. Airflow too high.
    - e. Ignitor module defective.
    - f. CAD cell defective.
    - g. Oil valve stuck open or closed.

**NOTE:** The Safety Monitoring Circuit (SMC) is designed to provide lockout in the event of a stuck or welded motor relay.

**NOTICE:** If flame is not established within 15 seconds of oil valve actuation (known as Trial For Ignition [TFI]) lockout will occur. Lockout is indicated by a red LED solid-on located on the oil primary control.

Hard Lockout will occur if the Oil Primary Control locks-out three (3) times during a call for heat. This is indicated by red light reset button solid-on.

### C. HYDROSTAT OIL BOILER CONTROL

Refer to the HydroStat 3250 Installation Instructions and Operating Manual included with these instructions.

## 15 Service Parts

All FORCE™ Repair Parts may be obtained by contacting your local Ferguson branch.

15 Service Parts (continued)

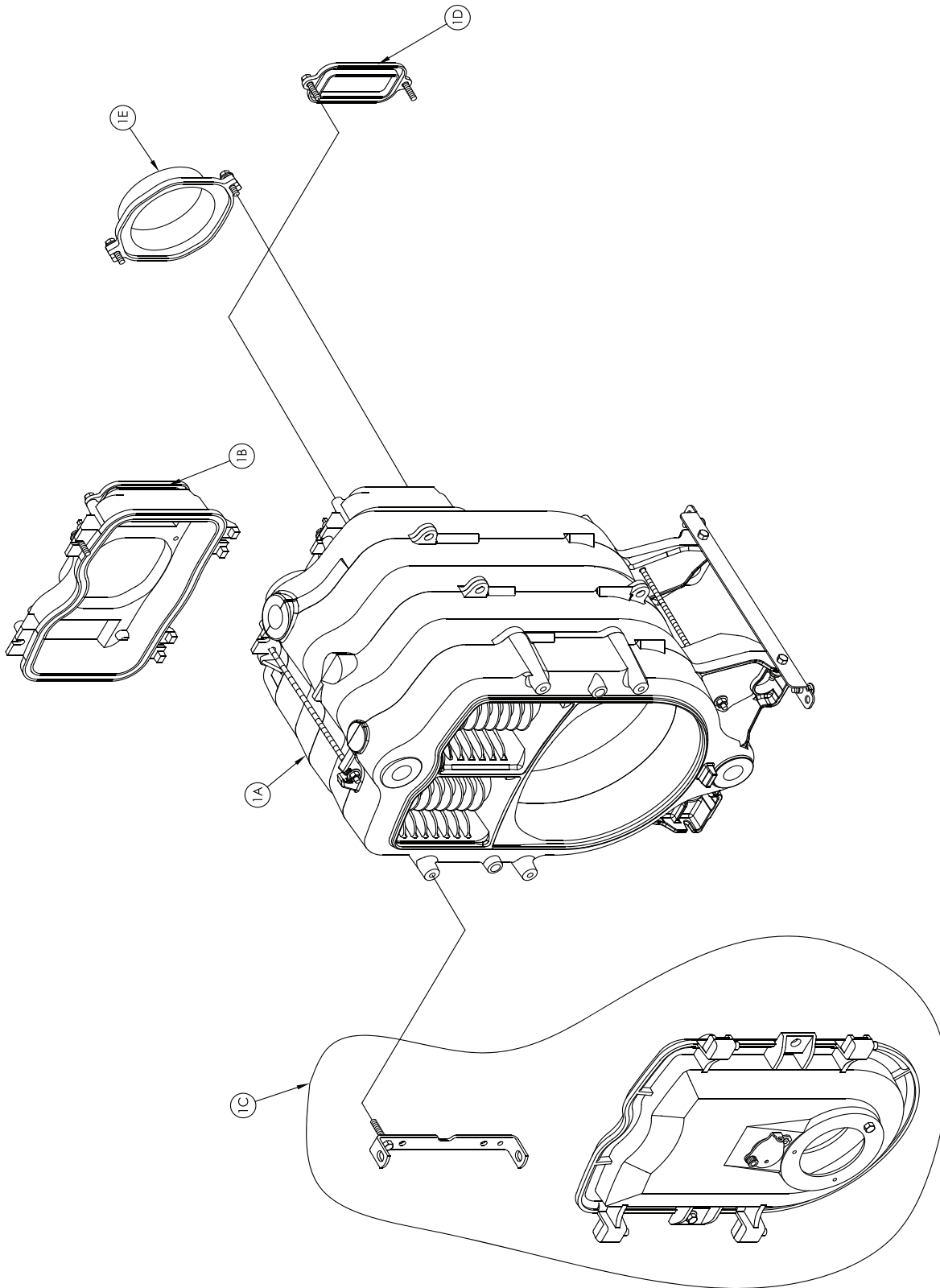

Bare Boiler Assembly



# 15 Service Parts *(continued)*

## FORCE OIL Bare Boiler Assembly

Item No.	Description	Part Number	FORCEOL84-E	FORCEOL115-E	FORCEOL140-E	FORCEOL182-E
1A	Block Assembly Includes: Block Assembly and Smoke Box	109554-02	1	1		
		109554-03			1	
		109554-04				1
1B	Smoke Box Includes: Sealant, and Hardware	109555-01	1	1	1	1
1C	Burner Swing Door Assembly	109556-01	1	1	1	1
1D	Cleanout Cover Assembly Includes: Hardware	109563-01	2	2	2	2
1E	Flue Collar Includes: Hardware	109567-01	1	1		
		109568-01		1	1	1
Not Shown	Combustion Chamber Gasket Kit	109738-01	1	1	1	1

15 Service Parts (continued)

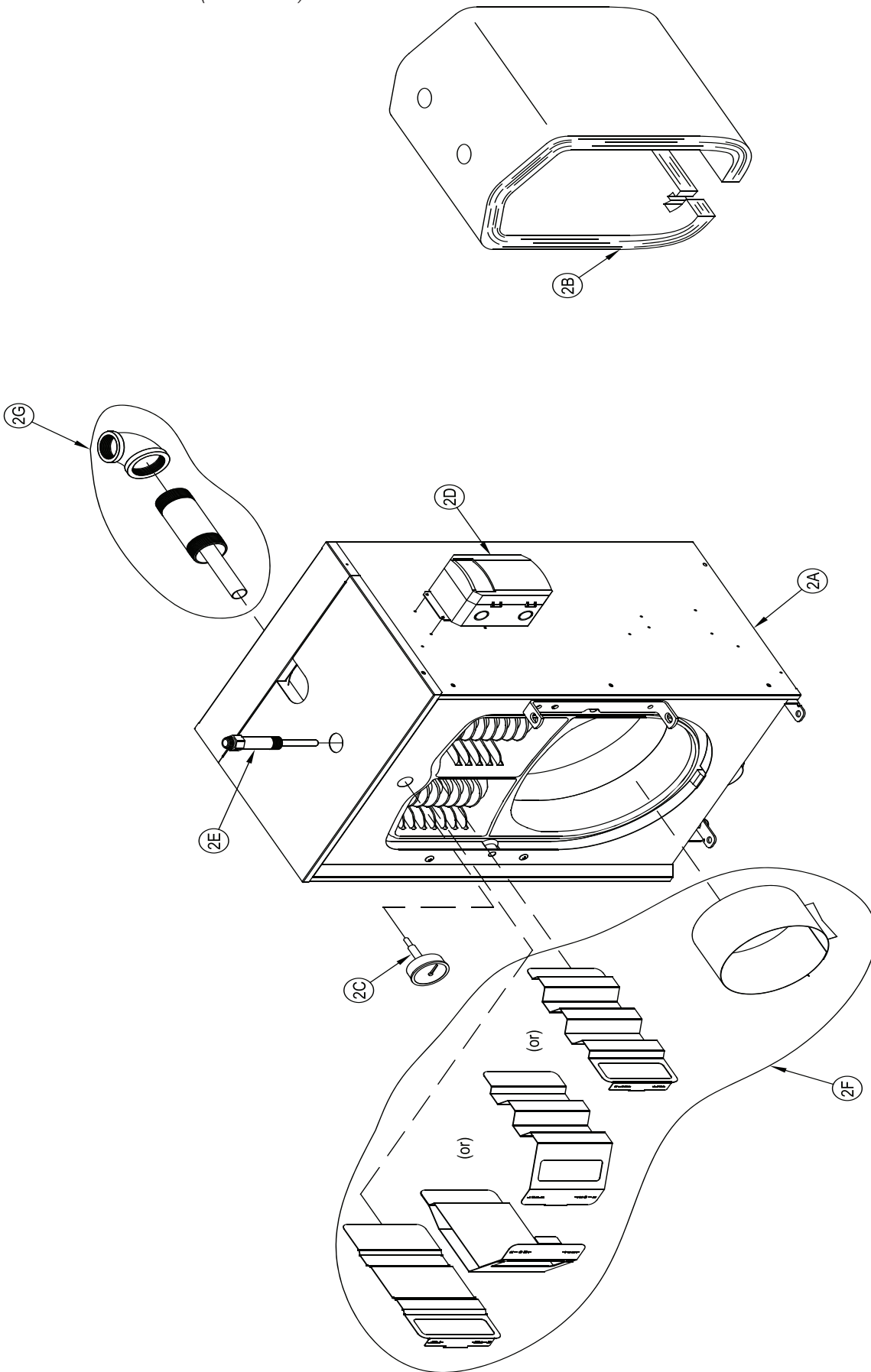

Jacket Assembly

# 15 Service Parts *(continued)*

Item No	Description	Part Number	FORCEOL84-E	FORCEOL115-E	FORCEOL140-E	FORCEOL182-E	
2A	Complete Jacket Carton Includes: Labels and Hardware	106443-02	1	1			
		106443-03		1	1		
		106443-04		1		1	
2B	Wrap Around Insulation	109553-02	1	1			
		109553-03			1		
		109553-04				1	
2C	Temperature & Pressure Gauge	105894-01	1	1	1	1	
2D	HydroStat 3250 Plus Includes: Remote Mounting Kit & 36" Sensor	109685-01	1	1	1	1	
2E	Electro-Well, 1/2" NPT x 3-1/4"	109566-01	1	1	1	1	
Not Shown	Harness, Limit to Burner	109868-01	1	1	1	1	
2F	Baffle Kit	109991-01	1				
		109990-01		1			
		109558-01			1	1	
2G	Injector Kit	102827-01	1	1	1	1	
Not Shown	Relief Valve, Conbraco, 3/4" FIP x 3/4" FIP	#10-408-05 30PSI	Obtain Locally	1	1	1	1
		#10-303-07 40 PSI					
		#10-303-10 50 PSI					
	5" Draft Regulator	1					
	6" Draft Regulator			1	1	1	
	Drain Valve, 3/4" NPT	1		1	1	1	
	Circulator Flange 1/2" NPT	2		2	2	2	
	Circulator Gasket Grundfos	2		2	2	2	
Circulator Grundfos Alpha2	1	1	1	1			

# 15 Service Parts *(continued)*

Item No.	Description	Part No.	FORCEOL140-E	FORCEOL182-E
<b>3. DIRECT VENT KITS AND PARTS</b>				
Not Shown	Direct Vent Conversion Kit	106401-01	1	1
	Adapter, Appliance, FDVS, 5-6	Included in kit	1	1
	Clamp, 6" Appliance, FDVS-6, Half		2	2
	Assy., Cover Sleeve, FDVS-5		2	2
	Assy., Cover Ring, FDVS-5		2	2
	Clamp, Inner Pipe FDVS-5, Half		4	4
<b>4. FLEX OIL VENT PIPE FOR DIRECT VENT</b>				
Not Shown	5" Dia. x 10 ft. FOVP-510	100212-02	1	1
	5" Dia. x 20 ft. FOVP-520	100214-02		

## 5. FORCEOIL Oil Burners

Item No.	Description		Part Number	FORCEOL84-E	FORCEOL115-E	FORCEOL140-E	FORCEOL182-E
Not Shown	Beckett	Natural Draft	102415-01	1			
			102415-02		1		
			102415-03			1	
			102415-04				1
		Direct Vent	106109-03			1	
	103369-01					1	
Primary Control	Beckett GeniSys 7505B	Obtain Locally	1	1	1	1	

# 15 Service Parts *(continued)*

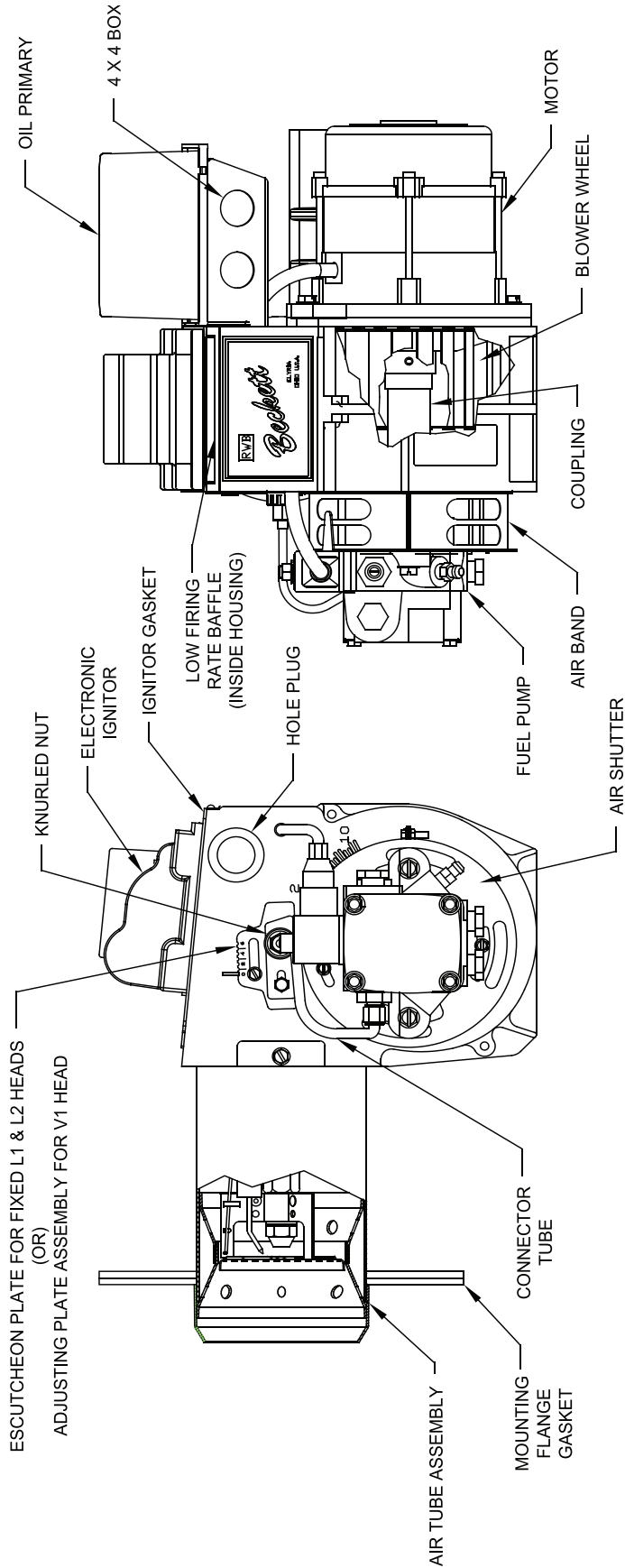

FRONT VIEW

SIDE VIEW

NOZZLE DETAIL

Beckett AFG Burner

# 15 Service Parts *(continued)*

## BECKETT AFG OIL BURNER PART NOS. FOR FORCE OIL SERIES BOILERS NATURAL DRAFT APPLICATIONS

NOTE: When ordering parts always give the serial and model numbers shown on the boiler and burner. Also provide the name of the part(s) and part number as listed below.

Boiler Model	FORCEOL84-E	FORCEOL115-E	FORCEOL140-E	FORCEOL182-E
Air Tube Combination	AFG70MQASN	AFG70MPASN	AFG70MMAQN	AFG70MLASN
Beckett's Spec. No.	NY2802	NY2803	NY2804	NY2805
Air Band	31840	31840	3492	3492
Air Band Nut	4150	4150	4150	4150
Air Band Screw	4198	4198	4198	4198
Air Shutter	3709	3709	3709	3709
Air Shutter Screw	4198	4198	4198	4198
Blower Wheel	2999	2999	2999	2999
Coupling	2454	2454	2454	2454
Low Firing Rate Baffle	3708	---	---	---
Bulkhead Knurled Locknut	3666	3666	3666	3666
Connector Tube Assembly	5636	5636	5636	5636
Electrode Clamp	149	149	149	149
Electrode Clamp Screw	4219	4219	4219	4219
Electrode Insulator Assembly	5780	5780	5780	5780
Spider Spacer Assembly	5503	5503	5503	5503
Escutcheon Plate	3493	3493	3493	5941
Adjusting Plate Assembly	---	---	---	5941
Head	51895	51895	5912	5913G
Head Screws	4221	4221	4221	4221
Flange Gasket	32388	32388	32388	32388
AFG Housing	5874	5874	5874	5874
Motor	21805	21805	21805	21805
Nozzle Adapter	213	213	213	213
Nozzle Line Electrode Assembly	NL70MB	NL70MB	NL70MM	NL70MD
Oil Pump, Clean Cut (Single Stage)	2184404U	2184404U	2184404U	2184404U
Oil Pump, Clean Cut (Two-Stage)	51975U	51975U	51975U	51975U
Static Plate	3384	3383	3384	---
Ignitor	51771U	51771U	51771U	51771U
Ignitor Hinge Screw	4217	4217	4217	4217
Ignitor Holding Screw	4292	4292	4292	4292
Ignitor Gasket Kit	51304	51304	51304	51304
Wire Guard	10251	10251	10251	10251
Junction Box	5770	5770	5770	5770
Flame Detector	7006	7006	7006	7006
Oil Solenoid Valve Coil	21775U	21775U	21775U	21775U
Oil Solenoid Valve Cord	21807	21807	21807	21807

# 15 Service Parts *(continued)*

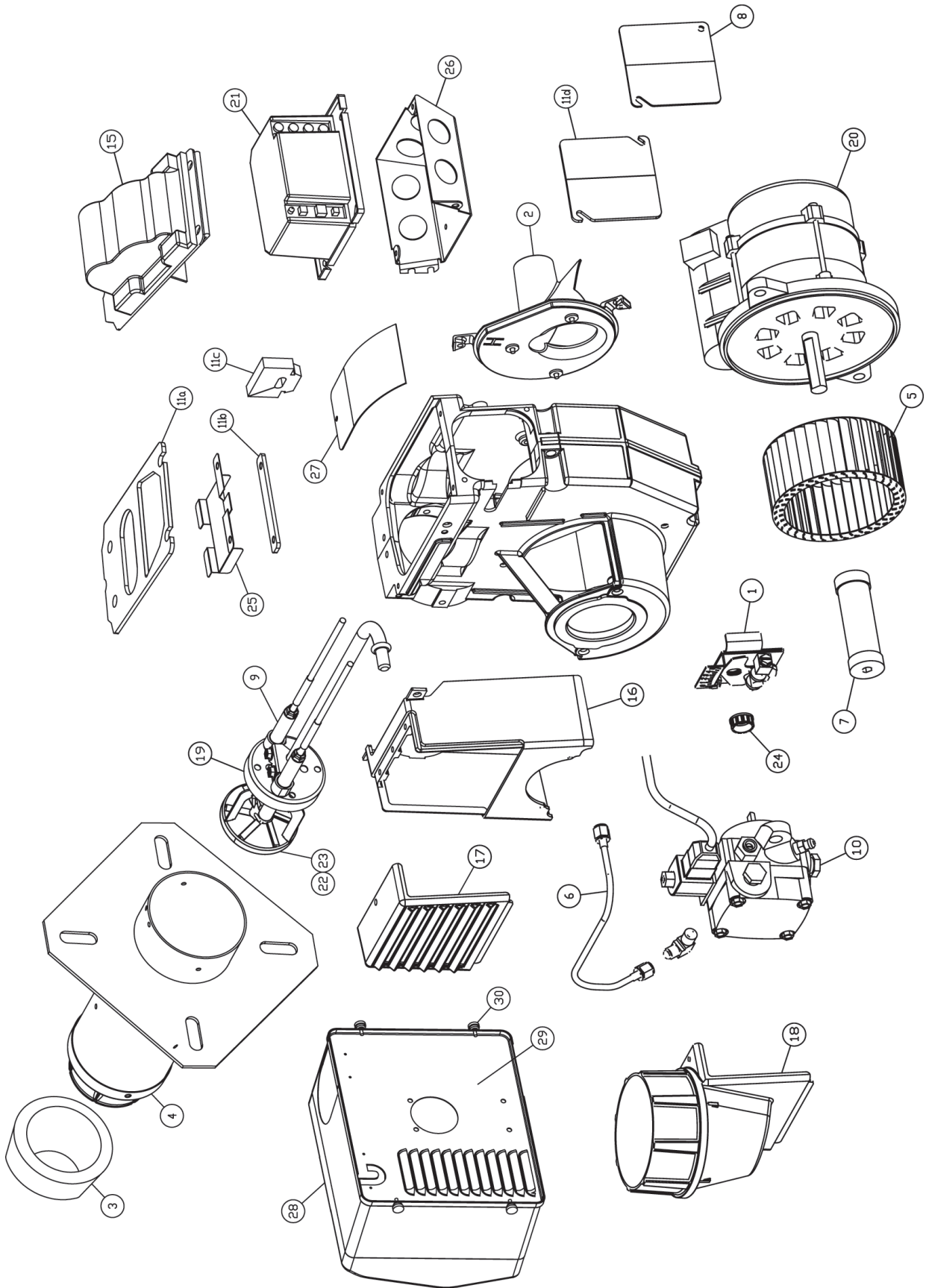

Beckett NX Burner

# 15 Service Parts *(continued)*

## BECKETT NX OIL BURNER PART NOS. FOR FORCE OIL SERIES BOILERS DIRECT VENT APPLICATIONS

NOTE: When ordering parts always give the serial and model numbers shown on the boiler and burner. Also provide the name of the part(s) and part number as listed below.

Item No.	Part Description	FORCEOL140-E	FORCEOL182-E
		Beckett Part Numbers	
	Complete Oil Burner (without Primary Control)	NY2905	NY2904
1	Air Adjustment Mechanism Assembly	51794U	
2	Air Guide	101101U	
3	Heat Shield (where used/optional)	Specify	
4	Air Tube Combination	NX70LB	NX90LD
	Air Tube Mounting Screws #8 x 3/8"	4396	
5	Blower Wheel	29994U	
6	Connector Tube Assembly, 11"	51127	
7	Coupling	2454	
8	Rear Access Door	32119U	
9	Electrodes Insulator Kit	51811U	
10	Fuel Unit, Single Stage, A2EA6520N621L	2184404U	
	Fuel Unit, Two Stage	51975U	
	Mounting Screws 1/4 -20 x 7/8"	4189	
11a	Gasket, Igniter Baseplate	51942U	
11b	Gasket, Igniter Baseplate Hinge		
11c	Gasket, Wiring		
11d	Gasket, Rear Access Door		
15	Igniter, Electronic	51771U	
16	Inlet Air Box	1010U	
18	Inlet Air Adapter, Outside Air Kit	1014U	
19	Nozzle Line Electrode and Head Assembly	Specify	
20	Motor	21805U	
	Mounting Screws 1/4 -20 x 7/8"	4189	
21	Primary Safety Control	Specify	
22	Retention Head Assembly - 6 Slot	51785U	
23	Retention Head Assembly - 9 Slot	51815U	
24	Splined Nut	3666	
25	Spring, Igniter Prop	32058PU	
26	Wiring Box	5770	
27	Low Firing Rate Baffle (If applicable)	32229U	
28	Cover, Burner	51812U	
29	Mounting Plate, Burner Cover	32103U	
30	Thumbscrews, Cover Mounting	21899U	
Not Shown	Gasket, Flange	32087	
	Main Housing Assembly	51783	
	Nozzle Line Heater (If applicable)	51621	



# 16 Burner Specifications

Boiler Model	Burner Input (GPH)	Burner Model	Nozzle	Air Shutter (setting)	Air Band (setting)	Pump Pressure (PSI)	Head Type (setting)	Insertion Depth (Inch)	Approx. Shipped CO <sub>2</sub> (%)	Baffle Location (pass)	Approx. Stack Temp. Increase Without Baffles °F <sup>(2)</sup>	Approx. Breech Pressure (" w.c.) <sup>(3)</sup>	Baffles IN Approx. Overfire Pressure (" w.c.) <sup>(3)</sup>	Baffles OUT Approx. Overfire Pressure (" w.c.) <sup>(3)</sup>
FORCEOL084-E	0.60	AFG	0.50 x 45W Delavan	6 <sup>(1)</sup>	0	150	L2	2	11.5	2 <sup>nd</sup>	---	0	---	+0.005
FORCEOL115-E	0.80	AFG	0.65 x 45B Delavan	6	0	150	L2	2	11.5	2 <sup>nd</sup> & 3 <sup>rd</sup>	84	0	+0.040	+0.020
FORCEOL140-E	1.00	AFG	0.85 x 60B Delavan	7	1	150	L1	2	11.5	2 <sup>nd</sup>	65	0	+0.040	+0.020
FORCEOL182-E	1.30	AFG	1.10 X 60B Hago	7	2	150	V1 (0)	2	11.5	2 <sup>nd</sup>	---	0	---	+0.030

**Notes**

- <sup>(1)</sup> FORCEOL084-E at 0.60 GPH firing rate utilizes a low fire baffle.
- <sup>(2)</sup> The increased stack temperature with the baffles removed is an approximation, based on a constant supply temperature of 180°F and 11.5% CO<sub>2</sub>. Actual field conditions may be different.
- <sup>(3)</sup> These values are minimum and could be as much as -.03" w.c., more without impacting performance. Pressures based on 11.5% CO<sub>2</sub>.
- <sup>(4)</sup> Single stage fuel pump is standard, two-stage fuel pump is optional. Burner manufacturer has preset single stage fuel pump to settings shown in table above. Two-stage fuel pump is factory set at 140 PSI and must be readjusted to settings shown above during burner start-up.

Boiler Model	Burner Input (GPH)	Head / Air Adjustment (setting)	Nozzle	Pump Pressure (PSI)	Approx. Shipped CO <sub>2</sub> (%)	Baffle Location (pass)	Approx. Stack Temp. Increase Without Baffles °F <sup>(2)</sup>	Baffles IN Minimum Overfire Pressure (" w.c.) <sup>(3)</sup>	Baffles OUT Minimum Overfire Pressure (" w.c.) <sup>(3)</sup>	Baffles IN Minimum Breech Pressure (" w.c.) <sup>(3)</sup>	Baffles OUT Minimum Breech Pressure (" w.c.) <sup>(3)</sup>
FORCEOL140-E	1.00	2.75	Delavan .75 x 60°W	180	11.5	2 <sup>nd</sup>	75	+0.06	+0.045	+0.045	+0.03
FORCEOL182-E	1.30	1.00	Hago 1.00 x 45°B	180		2 <sup>nd</sup>	70	+0.10	+0.05	+0.08	+0.04

**Notes**

- <sup>(2)</sup> The increased stack temperature with the baffles removed is an approximation, based on a constant supply temperature of 180°F and 11.5% CO<sub>2</sub>. Actual field values may be different.
- <sup>(3)</sup> These values are representative for max vent and air intake piping conditions @ 180°F supply water temperature and 11.5% CO<sub>2</sub>. Actual field values may be different.
- <sup>(4)</sup> Single stage fuel pump is standard, two-stage fuel pump is optional. Burner manufacturer has preset single stage fuel pump to settings shown in table above. Two-stage fuel pump is factory set at 140 PSI and must be readjusted to settings shown above during burner start-up.

# Appendix A: Aftermarket Low Water Cut Off (LWCO) On Hot Water Boilers

## ⚠ WARNING

- DO NOT ATTEMPT to cut factory wires to install an aftermarket Low Water Cut Off (LWCO). Only use connections specifically identified for Low Water Cut Off.
- In all cases, follow the Low Water Cut Off (LWCO) manufacturer's instructions.

### When

A low water cutoff is required to protect a hot water boiler when any connected heat distributor (radiation) is installed below the top of the hot water boiler (i.e. baseboard on the same floor level as the boiler). In addition, some jurisdictions require the use of a LWCO with a hot water boiler.

### Where

The universal location for a LWCO on both gas and oil hot water boilers is above the boiler, in either the supply or return piping. The minimum safe water level of a water boiler is at the uppermost top of the boiler; that is, it must be full of water to operate safely.

It is recommended that the LWCO control is installed above the boiler to provide the highest level of protection. However, where the LWCO control is approved by the LWCO control manufacturer for installation in a high boiler tapping of a water boiler, the use of the listed LWCO control is permitted when it is installed according to the LWCO manufacturer's instructions.

### What Kind

Typically, in residential applications, a probe type LWCO is used instead of a float type, due to their relative costs and the simplicity of piping for a probe LWCO.

### How to Pipe

A "tee" is commonly used to connect the probe LWCO to the supply or return piping, as shown below.

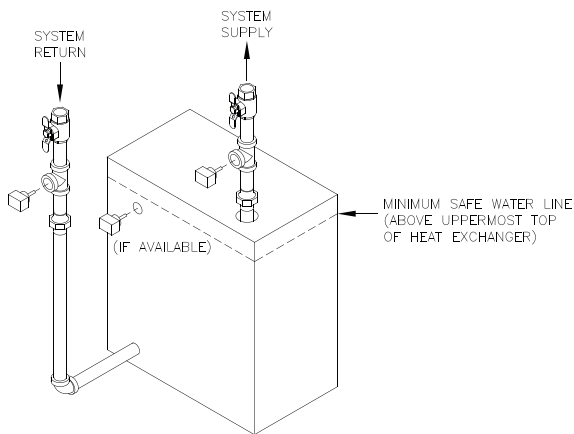

LWCO Location

Select the appropriate size tee using the LWCO manufacturer's instructions. Often, the branch connection must have a **minimum** diameter to prevent bridging between the probe and the tee. Also, the run of the tee must have a minimum diameter to prevent the end of the probe from touching or being located too close to the inside wall of the run of the tee.

Ideally, manual shutoff valves should be located above the LWCO and the boiler to allow for servicing. This will allow probe removal for inspection without draining the heating system. Many probe LWCO manufacturers recommend an annual inspection of the probe.

### How to Wire

LWCO's are available in either 120 VAC or 24 VAC configurations. The 120 VAC configuration can be universally applied to both gas and oil boilers by wiring it in the line voltage service to the boiler (after the service switch, if so equipped). The presence of water in a properly installed LWCO will cause the normally open contact of the LWCO to close, thus providing continuity of the 120 VAC service to the boiler.

It is recommended to supply power to the probe LWCO with the same line voltage boiler service as shown below.

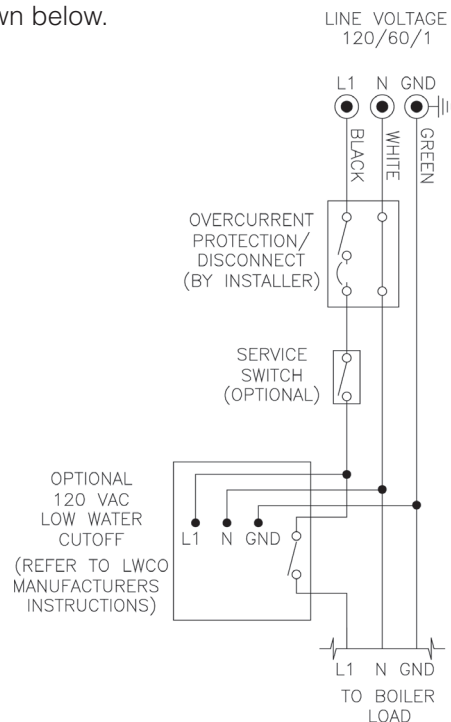

Wiring of Typical LWCO

## Appendix A: Aftermarket Low Water Cut Off (LWCO) On Hot Water Boilers

*(continued)*

A 24 VAC LWCO is used primarily for gas fired boilers where a 24 volt control circuit exists within the boiler. However, a 24 VAC LWCO can only be used if the boiler manufacturer has provided piping and wiring connections and instructions to allow for this application.

### How to Test

Shut off fuel supply. Lower water level until water level is BELOW the LWCO. Generate a boiler demand by turning up thermostat. Boiler should not attempt to operate. Increase the water level by filling the system. The boiler should attempt to operate once the water level is above the LWCO.

