

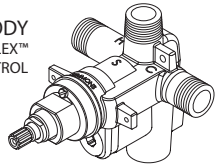

Temptrol® VersaFlex™ Pressure Balancing Valve S262BODY, S262XBODY Installation Instructions

S262BODY
VERSAFLEX™
DIVERTER CONTROL



S262XBODY
VERSAFLEX™
DIVERTER CONTROL
EASYSERVICE™
STOPS

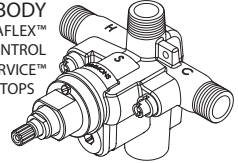

COMPLIANCE

- ASME A112.18.1/CSA B125.1
- ASSE 1016
- Buy American Act Compliant



IMPORTANT / FOR INSTALLER

⚠ WARNING:

As the installer of this valve, you must first carefully read and understand the material covered in this manual before installing and adjusting this valve per instructions. Failure to do so may compromise the installation, operation and/or serviceability of this valve.

DO NOT install positive shut-off devices on the outlet of this valve, or devices that do not allow the valve to flow at least 1.5 GPM at 45 psi inlet pressure. Exception: If a self-closing or slow-closing valve is installed on the outlet, the supplies of the valve must be equipped with checks to eliminate hot to cold bypass in the event the valve's handle is not turned off after use.

When installing this valve, failure to adjust limit stop screw properly may result in serious scalding.

LIFETIME LIMITED WARRANTY

All warranty claims MUST be pre-approved by Symmons.

All parts and finishes of the Symmons products are warranted to the original consumer purchaser to be free from manufacturing defects in material and workmanship for 5 years Non-Residential or Commercial Applications. Symmons warrants to the original consumer purchaser/ end-user that any Symmons product will be free of defects in material and workmanship during normal domestic use for the life of your home.

Symmons recommends using a professional plumber for all installation and repair. During the warranty period, Symmons at its sole option, will provide replacement part(s) or product (or, if no longer available, a comparable product) to replace those which have proven defective in materials or workmanship under normal installation, use and service, FREE OF CHARGE for the time period of 5 years from the date of purchase. (BATTERIES NOT INCLUDED)

This warranty is extensive in that it covers replacement of all defective parts and even finish, but these are the only two things that are covered. Damage due to installation error, product abuse, product misuse, or use of cleaners containing abrasives, alcohols, or other organic solvents, whether performed by a contractor, Service Company or yourself are excluded from this warranty. Symmons will not be responsible for labor charges and/or damage incurred in installation or repair or replacement, nor for any indirect, incidental or consequential damages, losses, injury or costs of any nature relating to the bathing products. Except provided by law, this warranty is in

lieu of and excluded all other warranties, conditions and guarantees, whether expressed or otherwise, including without restriction those of merchantability or of fitness for use.

Some states do not allow the exclusion or limitation of incidental or consequential damages, so the above limitation of exclusion may not apply to you. This warranty gives you specific legal rights, and you also may have other rights which vary from state to state. This warranty is not transferable. This warranty does not cover damage or defects relating to misuse, abuse, negligence, normal wear and tear, accident, acts of God, repairs or alterations not authorized in writing by Symmons, or improper installation, storage or handling.

The above mentioned warranty information includes each product that falls under the following: Symmons Bathing Products Warranty- Non-Residential or Commercial Applications; Symmons Non-Electronic Lifetime Faucet and Finish Limited Warranty Non-Residential or Commercial Applications; Symmons Electronic Faucet Limited Warranty - Non-Residential, Commercial and Residential Applications; Symmons Bathing Products Warranty- Residential Application Symmons Non-Electronic Lifetime Faucet and Finish Limited Warranty Residential Application

If you have any questions regarding technical support, installation or concerns regarding our warranty plan, please email us at GetHelp@symmons.com or call us at: 1-800-796-6667.

1. RECOMMENDED TOOLS

Copper, IPS, CPVC, PEX (Crimp) & PEX (Cold Expansion), ProPress

FIGURE 1

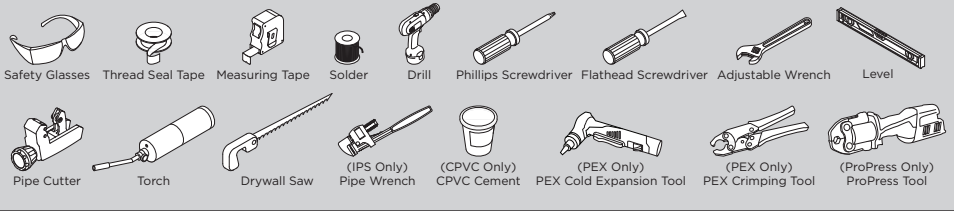

2. BRACKET INSTALLATION (P/N: S262BRBODY, S262XBRBODY)

2.1 Metal Straps

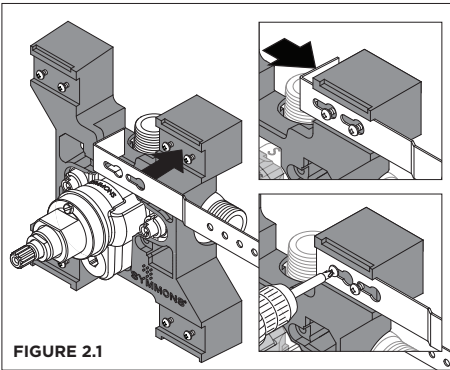

Rapid Install™ Bracket is used to secure valve between wall studs up to 24 inches, center to center. Bracket will fit in minimum 2x3 wall cavity. Bracket will rough valve at 2-7/8" from centerline of valve ports to front of finished wall.

1. Place metal straps (x4) over screws. Screws will come preassembled to bracket.
2. Pull metal straps tight against bracket ears. Screws will protrude through small screw hole in metal straps.
3. Drive screws into bracket to secure straps. **⚠** Use caution not to strip screws.

NOTE: Valve will come preassembled to mounting bracket unless otherwise specified.

2.2 Install Bracket

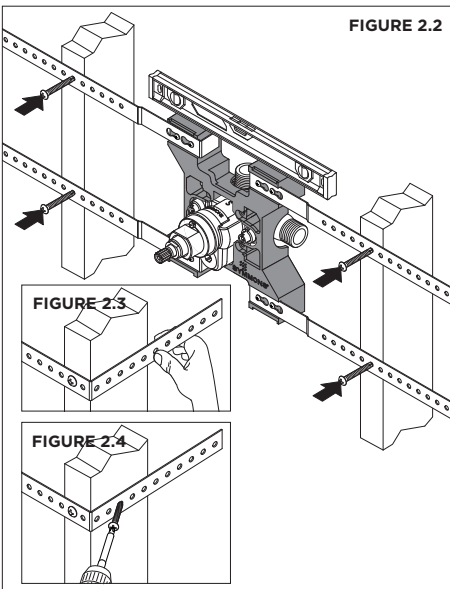

Rapid Install™ Bracket will locate valve body in wall cavity at appropriate depth (valve body rough-in is not required).

1. Confirm valve body and mounting bracket are level. Drive (x4) wood screws through metal straps into wood studs (see FIGURE 2.2)
2. Bend excess strap around wood studs. (see FIGURE 2.3)
3. Drive (4x) wood screws, at inward angle, through metal straps into sides of wood studs (see FIGURE 2.4). Installing wood screws at inward angle will pull metal straps tight against wood studs.

NOTE: If not using mounting bracket, see STEP 5.1 for stringer mounts installation.

3.1 Tub/Shower Systems

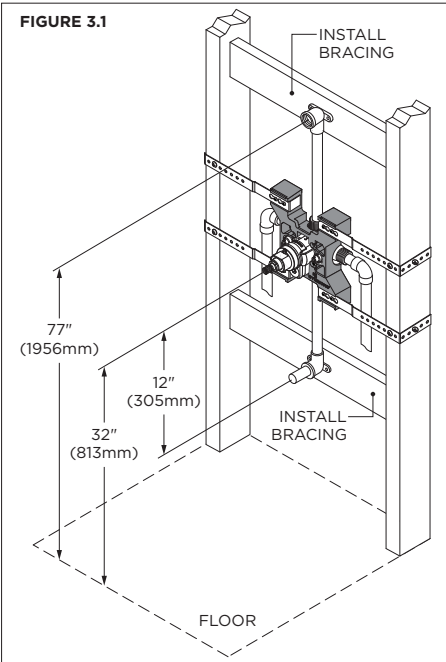

Valve should be positioned 32 inches above the tub basin floor. Shower arm should be 77 inches above the tub basin floor. Tub spout should be positioned approximately 12 inches below the valve.

3.2 Shower/Hand Shower Systems

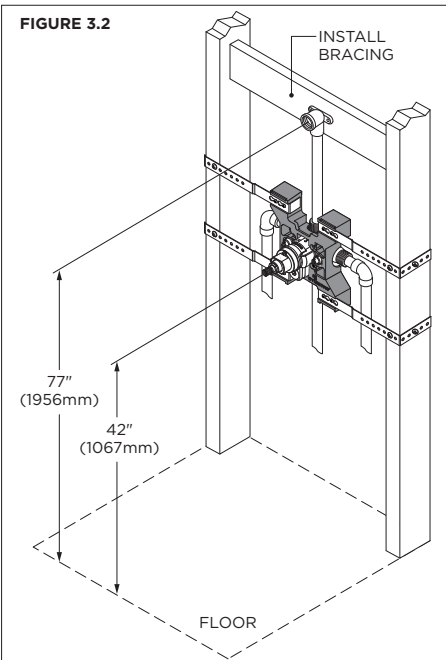

Valve should be positioned 42 inches above the tub basin floor. Shower arm should be 77 inches above the tub basin floor.

NOTE: For ADA compliance (Americans with Disabilities Act) consult your local municipality for proper product choice and mounting locations.

4. DETERMINE WALL TYPE

4.1 Protective Shield

FIGURE 4.1

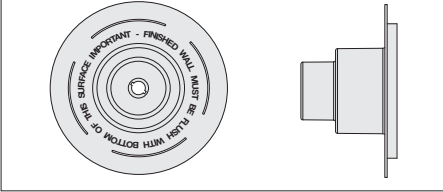

4.3 Drywall or Other Type Wall

FIGURE 4.3

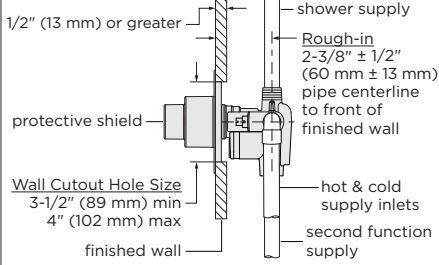

4.4 Thin Wall Installation

FIGURE 4.4

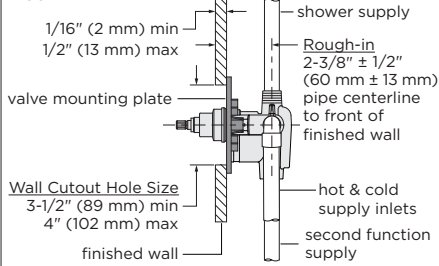

4.5 Alternative Rough-ins

FIGURE 4.5

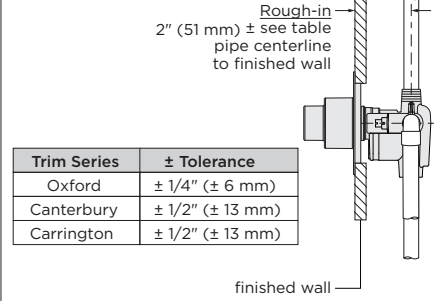

4.2 Valve Mounting Plate

FIGURE 4.2

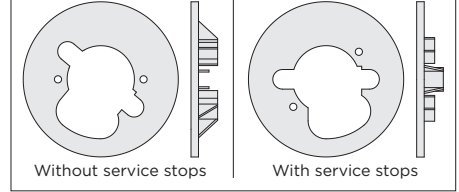

Protective shield is required for drywall, plaster or other type walls with:

- 1/2 inch (13 mm) or greater wall thickness

1. Attach protective shield by snap fitting over end of valve spindle to protect valve during wall construction.
2. Finished wall must be flush with back side of protective shield surface.

Valve mounting plate is required for fiberglass or acrylic walls, and optional for plaster or other type walls with:

- Minimum 1/16 inch (2 mm) wall thickness
- Maximum 1/2 inch (13 mm) wall thickness

1. Seat mounting plate against valve (see FIGURE 4.2 for orientation).
2. Valve mounting plate must be flush with inner wall.

When installing valve used with any of the shower or tub/shower trims shown below, reference rough-in dimensions as shown in FIGURE 4.5 instead of standard valve rough-in:

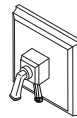

Oxford

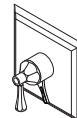

Canterbury



Carrington

5.1 Stringer Mounts

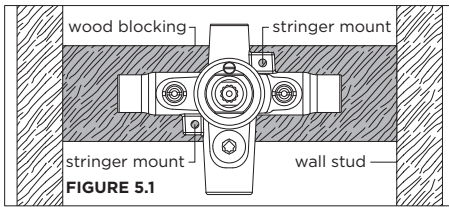

Stringer mounts are used to secure valve body to wood blocking for valve bodies without Rapid Install™ Bracket (see FIGURE 5.1).

For installation with Rapid Install™ Bracket see STEPS 2.1 & 2.2.

5.2 Install Piping/Fittings (Bracket Removed for Clarity)

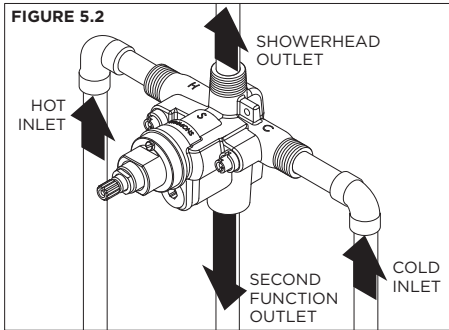

1. Install valve as specified in FIGURES 4.3 - 4.5, per application.
2. Pipe from outlet port on the valve marked S to showerhead mounting arm location.
3. Connect hot water supply to valve inlet marked H and cold water supply to valve inlet marked C.
4. Pipe from outlet port on valve marked T to tub spout or other Symmons accessory.
5. Remove protective shield snap fitted over the end of valve flow control spindle once valve is securely installed and wall finish work has been completed.

5.3 Adjust Valve Packing Nut

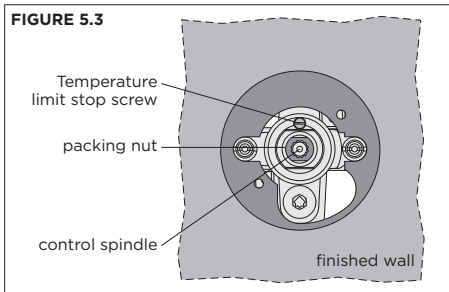

1. Turn hot and cold supplies on. Valve will not operate unless both hot and cold water supply pressures are on.
2. Place handle over flow control spindle.
3. Tighten packing nut for positive frictional resistance as handle is rotated from shut-off position across adjustment range.

5.4 Flush System

1. Turn valve to the warm position and run for a few minutes.
2. If system is dirty, remove TA-10 flow control spindle in center of valve to ensure proper flushing (see STEP 9.1).
3. Check for leaks around valve assembly and all pipe fittings.

5.5 Set Temperature Limit Stop Screw

The temperature limit stop screw limits valve handle from being turned to maximum position, resulting in excessive hot water discharge temperatures.

⚠ WARNING: Failure to adjust temperature limit stop screw properly may result in serious scalding.

1. Place handle on flow control spindle and open valve to maximum desired temperature.
2. Turn limit stop screw clockwise until it seats (see FIGURE 5.3).

6. BACK TO BACK INSTALLATION

6.1 Back to Back Wall Type

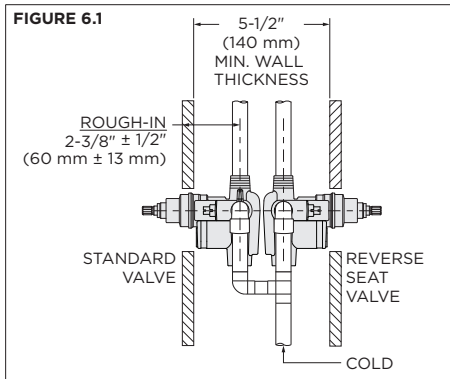

1. To simplify piping on back to back installations, use one standard valve (hot on left, cold on right) and one SureGrip™ reverse seat valve (hot on right, cold on left) as shown in FIGURE 6.1.

NOTE: Back to back installations require 5-1/2" (140 mm) minimum wall thickness for proper installation, with or without bracket.

6.2 Identify Reverse Seat Valve

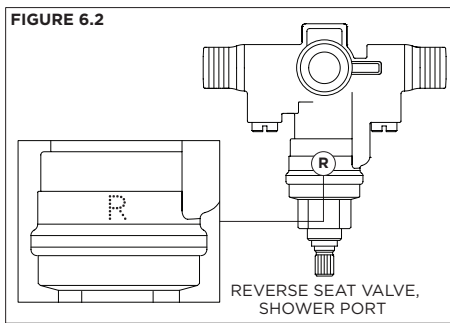

1. Locate the "R" stamp on shower port side of the valve body to identify SureGrip™ reverse seat valve as shown in FIGURE 6.2.

NOTE: Standard valve body will feature an "S" stamp.

6.3 Install Piping/Fittings (Bracket Removed for Clarity)

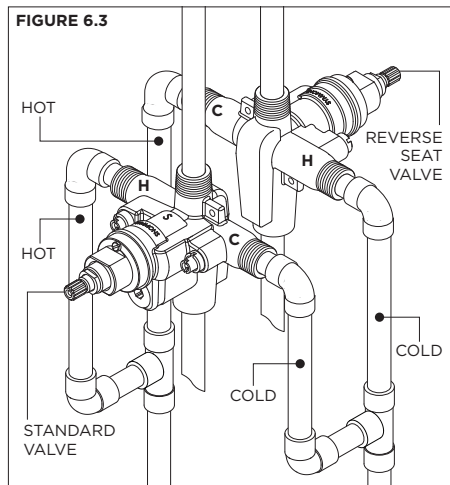

1. Inlet marked H on standard valve should be plumbed to inlet marked C on SureGrip™ reverse seat valve.
2. Inlet marked C on standard valve should be plumbed to inlet marked H on SureGrip™ reverse seat valve (see FIGURE 6.3).
3. Follow STEPS 5.3 - 5.5 to complete installation of valve bodies.

7.1 Install Valve Body with ProSafe™ Test Cap

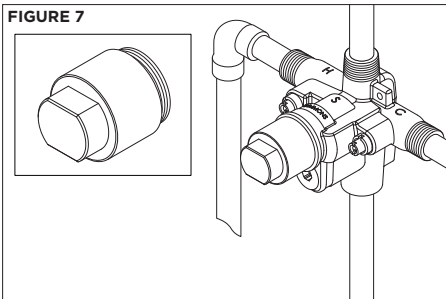

Test cap will come installed to valve to allow pressurization of system. DO NOT remove test cap from valve during wall construction, installation of valve or pressurization of system.

⚠ WARNINGS:

1. Test cap rated for pressure testing up to 200 psi maximum. DO NOT exceed 200 psi while pressure testing valve body.
2. Do not expose valve with test cap to heat for longer than 2 minutes when soldering copper tubing. Doing so may damage the internal components of the valve and will void the product warranty.
3. Ensure test cap is re-torqued to 30 lb-ft after soldering valve body.

To install valve body with test cap, follow instructions outlined in STEP 5.2.

7.2 Preparing Valve Body with ProSafe™ Test Cap for Trim

TA-10 flow control spindle will be included with shower and tub/shower trim. When ready to install trim to valve:

1. Check for leaks around the valve assembly and all pipe fittings.
2. Remove test cap from valve.
3. If system is dirty, flush valve.
4. Install flow control spindle and cap assembly to valve (see STEP 9.5).
5. Adjust packing nut and set temperature limit stop screw (see STEPS 5.3 & 5.5).

8. VALVE BODY OPERATION

8.1 Operate Temperature

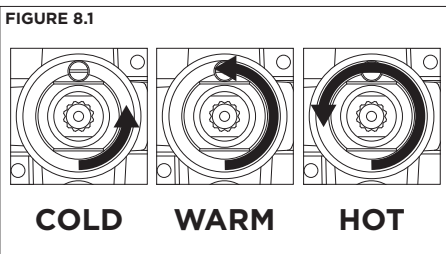

(Reference FIGURE 8.1)

Turn valve stem counter-clockwise approximately 1/4 turn to put valve in cold position.

Turn valve stem counter-clockwise approximately 1/2 turn to put valve in warm position.

Turn valve stem counter-clockwise approximately 3/4 turn to put valve in hot position.

8.2 Operate Diverter Control

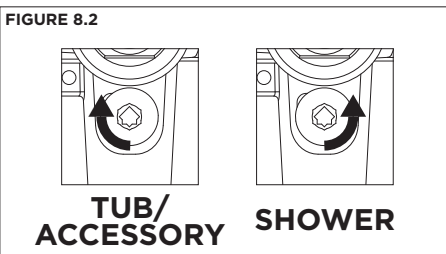

(Reference FIGURE 8.2)

Turn diverter cartridge clockwise to divert to tub spout or Symmons accessory.

Turn diverter cartridge counter-clockwise to divert to shower.

9. SERVICE INSTRUCTIONS

9.1 Removing Flow Control Spindle

Reference parts breakdown (see FIGURE 10.1). See trim manual for trim removal instructions.

1. Shut off water supply to valve. Turn TA-10 flow control spindle to open position using trim handle.
2. Remove trim handle and dome cover.
3. Remove escutcheon plate by first removing escutcheon screws.
4. Unscrew both T-12A cap assembly and flow control spindle together.

9.2 Hot/Cold Seat Repair Kit

Service requires TA-4 hot and cold seat kit and T35C removal tool kit.

1. Remove flow control spindle (see STEP 9.1).
2. Remove both seats with removal tools, turning counterclockwise.
3. Replace both seats even if only one appears worn.
4. Install and tighten both seats to 15 foot pounds of torque, turning clockwise.

9.3 Flow Control Spindle Washer Repair Kit

Service requires TA-9 washer repair kit.

1. Remove flow control spindle (see STEP 9.1).
2. Remove cold washer by holding flow control spindle using trim handle and unscrew cold washer retainer using channel lock pliers, turning counterclockwise.
3. Remove hot washer by removing hot washer screw.

9.4 Checking Water Pressure Balancing Piston

The perforated end of the flow control spindle houses the water pressure-balancing piston.

1. Remove flow control spindle (see STEP 9.1).
2. Shake flow control spindle and listen for clicking noise. Piston should be free to slide back and forth the full length of its travel.
3. If piston appears restricted then do the following: a) tap the handle, or the stem end of flow control spindle, against a solid object to free the piston, or b) try soaking in household vinegar and repeat tapping handle or stem of flow control spindle.
4. If unable to free piston, replace flow control spindle.

9.5 Valve Reassembly

Reassemble valve, reversing the procedure in STEP 9.1. Be sure flow control spindle is drawn close to the cap before screwing cap assembly back into valve.

9.6 Removing VersaFlex™ Diverter Control Cartridge

Reference parts breakdown (see FIGURE 10.1). Service requires 5/16 inch hex wrench.

1. Remove RTS125 retaining nut with 5/16 inch hex wrench.
2. Insert hook end of removal tool (provided in RTS124 diverter cartridge kit) into key hole opening of diverter cartridge. Pull removal tool to remove diverter cartridge from valve body. Tool allows removal of cartridge at deepest allowable rough-in.
NOTE: Do not damage back surface of valve body with tool if removing rear seal of cartridge.
3. Verify all bore surfaces are clean and free of debris. If necessary, clean bore surfaces with a nylon or soft bristle brush only (DO NOT use stainless steel, brass or abrasive brushes).
4. Inspect cartridge for debris. Cartridge cannot be serviced and must be replaced if necessary.

9.7 VersaFlex™ Diverter Control Cartridge Reassembly

Reference parts breakdown (see FIGURE 10.1).

Service requires 5/16 inch hex wrench.

1. Ensure o-ring seal on cartridge is greased before inserting into valve body.
2. Orient cartridge as shown in FIGURE 10.1. Insert cartridge into valve body.
3. Install RTS125 retaining nut with 5/16 inch hex key.
IMPORTANT: RTS125 must be secured tightly to prevent leak-by between functions.

FIGURE 10.1

COMMON PLANE
VALVE BODY
S262XBODY (PICTURED)
S262BODY

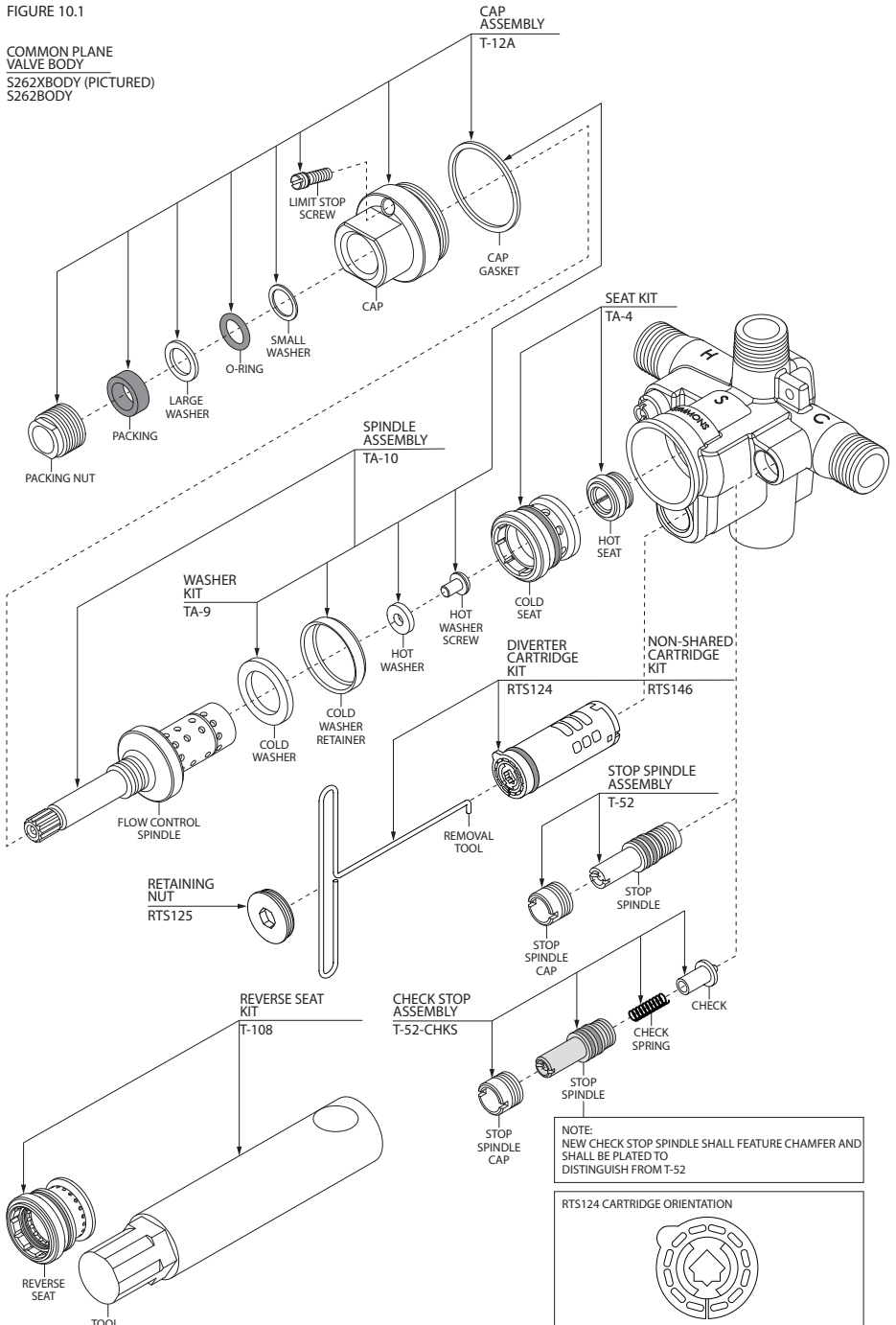

10. PARTS BREAKDOWN

FIGURE 10.2

VALVE BODY FITTING MODIFICATIONS

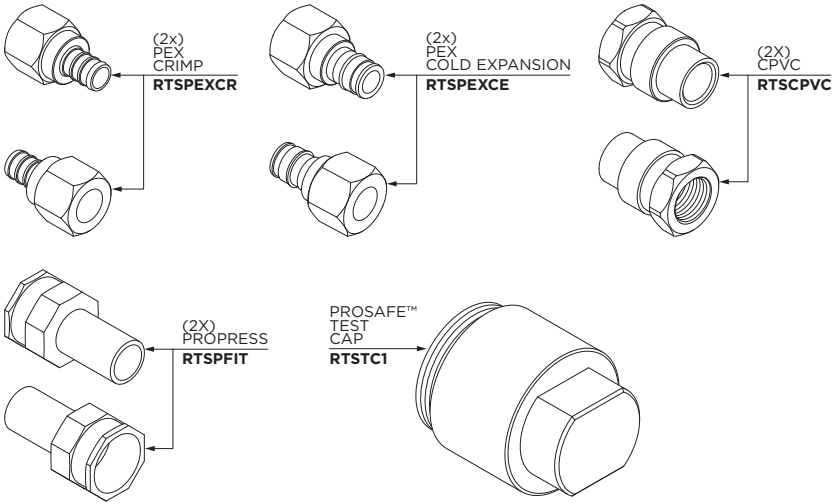

MOUNTING BRACKET COMPONENTS

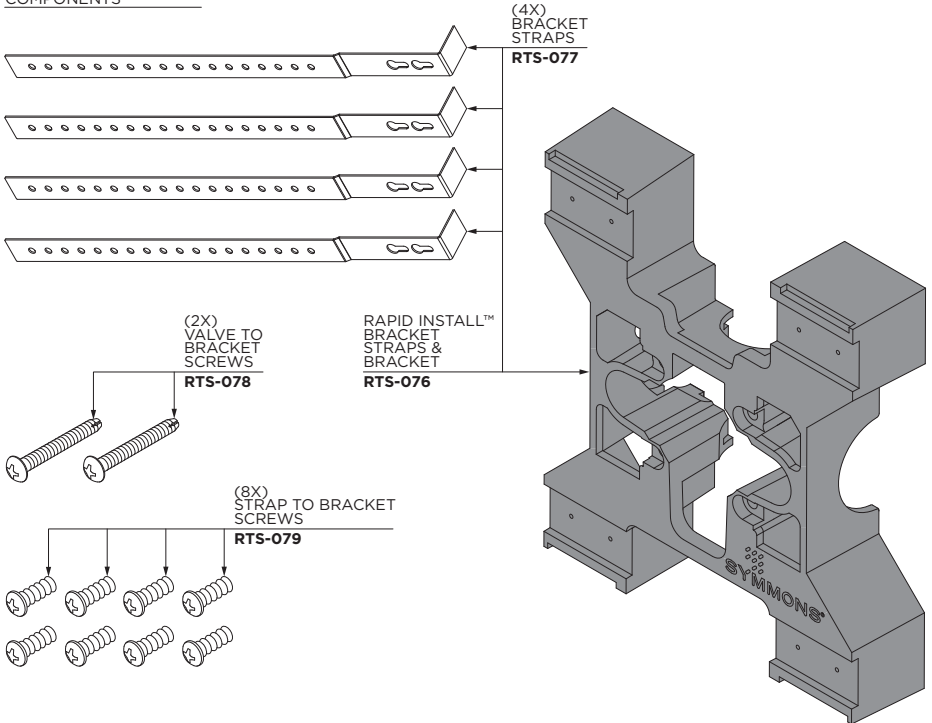

11.1 T35C REPAIR TOOL ASSEMBLY

Repair tool assembly can be used to service the following:

- Temptrol stop spindle cap (T-52-CHKS)
- Temptrol diverter retainer (RTS125)
- Temptrol cold seat (TA-4)
- Temptrol hot seat (TA-4)
- Temptrol legacy cold seat
- Temptrol legacy hot seat

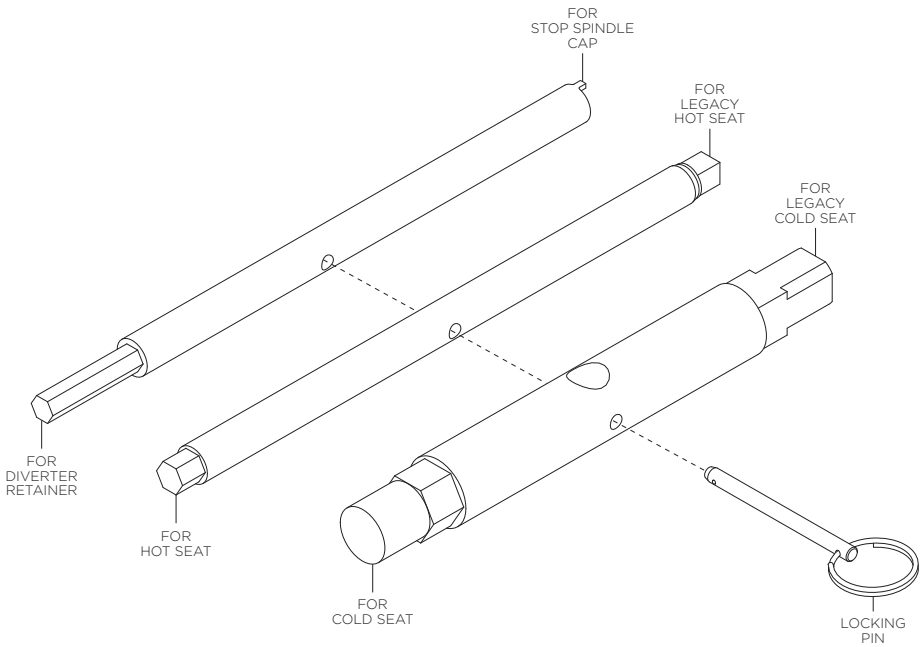

Slide unused corresponding tool through center hole of desired tool and secure with locking pin.
See image below for reference.

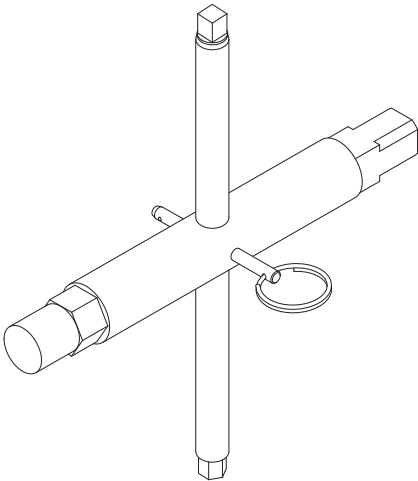

12. TROUBLESHOOTING CHART

PROBLEM	CAUSE	SOLUTION
Valve will not pass water.	Both hot and cold water supplies are not turned on.	Turn on both supplies. Valve will not operate unless both hot and cold water pressure is on.
Valve leaks when shut off.	Hot and cold washers are worn or foreign matter (dirt, chips) is lodged between washers and seat surfaces.	Replace washers using TA-9 washer repair kit. Replace hot & cold seats using TA-4 hot/cold seat repair kit.
Temperature control handle is turned from cold to hot (or hot back to cold) and volume from spout or head is not constant.	Pressure-balancing piston housed in spindle assembly is restricted from free movement by foreign matter.	Open valve halfway, remove handle and tap spindle with plastic hammer. Check water pressure balancing piston in control spindle. See service instructions. Replace TA-10 flow control spindle.
Valve delivers sufficient quantity of cold, but little hot, or the reverse.	Same as above.	Same as above.
Temperature varies without moving handle.	Same as above.	Same as above.
Valve delivery temperature reduces gradually during use; handle must be turned to hotter positions to maintain constant temperature.	Overdraw on hot water supply (i.e. running out of hot water).	Reduce maximum flow by using volume control adjustment on valve or showerhead. This will allow longer period of use before overdrawing hot water supply.
Valve delivers hot water when initially opened. Water turns colder as handle is rotated in a counterclockwise direction toward the hot position.	Valve is piped incorrectly (i.e. the hot supply is piped to the valve's cold inlet and the cold supply is piped to the hot inlet.)	If piping is accessible, correct connections to the valve. If piping is not accessible, order T-108 reverse seat and tool kit. Older installations may also require replacing the TA-4 hot/cold seat repair kit.

 **WARNING:** This product can expose you to chemicals including lead, which is known to the state of California to cause cancer, birth defects, or other reproductive harm. For more information, go to www.P65Warnings.ca.gov.

Symmons Industries, Inc. ■ 31 Brooks Drive ■ Braintree, MA 02184

Phone: (800) 796-6667 ■ Fax: (800) 961-9621

symmons.com ■ gethelp@symmons.com

Copyright © 2020 Symmons Industries, Inc. ■ 081021