

SPECIFICATIONS

FIGURE X450 FORGED BRONZE BALL VALVES



LOW-LEAD COMPLIANT 2 PC FULL PORT 600 WOG

FEATURES

- 600 WOG
- Forged bronze body and end cap
- Specially formulated dezincification-resistant silicone bronze
- 400 psi maximum for FM-approved applications
- 150 WSP
- Full port
- NSF 61 and NSF 372 (UL) Certified
- Threaded NPT ends (ANSI B1.20.1)
- 100% electronically tested in open and closed position at 80 psi
- Meets MSS SP-110 standards
- FM and CSA approved (1/2"–2")
- Blowout-proof stem
- Dual O-ring
- Adjustable packing

Not for direct buried service



ACCESSORIES (SOLD SEPARATELY)

- Lock Lever Kit (1/2"–2")
- Stem Extension Kit (1/2"–2")
- Tee Handle Kit (1/2"–1")
- Oval Handle Kit (1/2"–2")
- Memory Stop Kit (1/2"–2")
- Stainless Handle (1/2"–2")

GAS APPROVALS

- CSA Class 3371-08, ANSI Z21.15/CSA9.1, 1/2 PSIG, -40°F–149°F
- CSA Class 3371-10, CGA 3.16, 125 PSIG, -40°F–49°F
- CSA Class 3371-12, CR91-002, 2 & 5 PSIG, -40°F–149°F
- CSA Class 3371-88, ANSI Z21.15/CSA9.1, 1/2 PSIG, -40°F–149°F
- CSA Class 3371-90, ASME B16.33/B16.38, 125 PSIG, -40°F–149°F
- CSA Class 3371-92, ASME B16.44, 5 PSIG, -40°F–149°F

FIGURE NUMBER MATRIX

FNW X450	Size	
	D = 1/2"	H = 1-1/4"
	F = 3/4"	J = 1-1/2"
	G = 1"	K = 2"

KIT CODES

Product Type	Size
Locking Handle = LHK	1/4"–1/2" = BD
Stem Extension = SE	3/4"–1" = FG
Tee Handle = THK	1-1/4"–1-1/2" = HJ
Oval Handle = OHK	2" = K
Memory Stop = MSK	
Stainless Handle = SSHK	

Note: The figure X450 uses the same accessories as the 420.

PRESSURE/TEMPERATURE

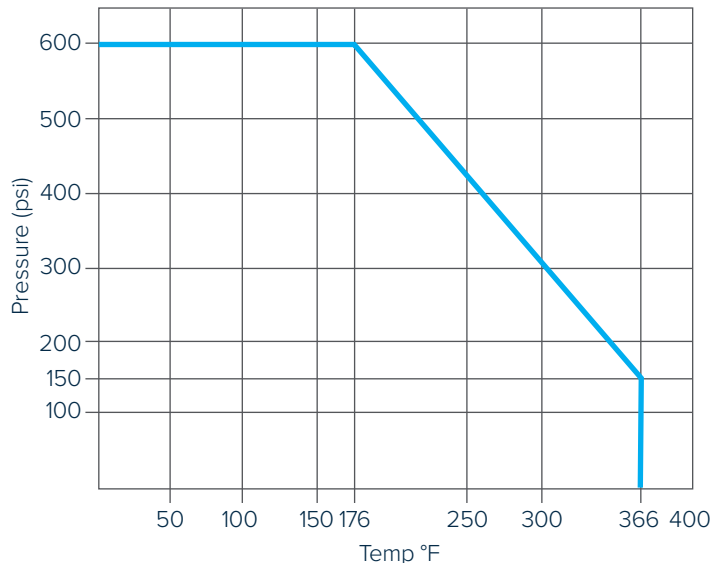

PARTS BREAKDOWN

FIGURE X450

FORGED BRONZE BALL VALVES



LOW-LEAD COMPLIANT 2 PC FULL PORT 600 WOG

PARTS DIAGRAM

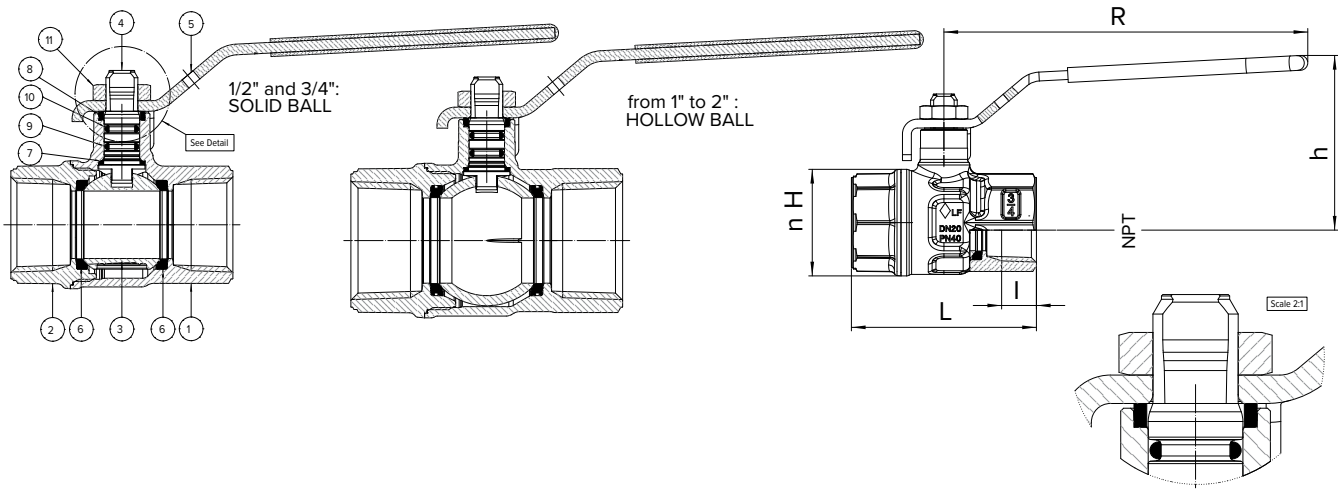

DIMENSIONS (INCHES)

Size	ø P	I	L	ø H	CH	R	h	psi
1/2"	0.55	0.54	2.22	1.18	0.98	3.78	1.77	600
3/4"	0.75	0.55	2.46	1.42	1.22	4.84	2.22	600
1"	0.94	0.66	3.01	1.71	1.50	4.84	2.32	600
1-1/4"	1.19	0.68	3.37	2.09	1.89	5.94	2.85	600
1-1/2"	1.50	0.68	3.70	2.56	2.13	5.94	3.09	600
2"	1.95	0.70	4.33	3.39	2.64	6.30	3.70	600

CV & WEIGHTS

Size	Cv	Wt. (lbs)
1/2"	19	0.41
3/4"	34	0.69
1"	45	0.99
1-1/4"	75	1.70
1-1/2"	180	2.29
2"	210	3.92

PART MATERIALS & QUANTITY

Ref #	Description	Material	Qty
1	Body	Bronze	1
2	End Connection	Bronze	1
3	Solid Ball 1/2" and 3/4"	Brass CW 510L (Chrome-Plated)	1
	Hollow Ball 1" to 2"	Brass CW 510L (Chrome-Plated)	1
4	Stem	Brass CW 510L	1
5	Handle	Steel DD11	1
6	Ball Seat	PTFE	2
7	Thrust Water	PTFE	1
8	Packing Ring	PTFE	1
9	O-Ring	NBR	1
10	O-Ring	FKM	1
11	Nut	Steel CL 04	1