

SPECIFICATIONS

FIGURE X451 FORGED BRONZE BALL VALVES



LOW-LEAD COMPLIANT 2-PC FULL PORT 600 WOG

FEATURES

- Two trims available:
 - Fig. X451: Brass CW 510L chrome-plated ball and brass CW 510L stem
 - Fig. X451SS: 316 stainless steel ball and stem
- RPTFE seats available with stainless steel trim option
- Forged bronze body and end cap
- Specially formulated dezincification-resistant silicone bronze
- 600 WOG
- 150 WSP
- Full port
- 100% electronically tested in open and closed position at 80 PSI
- Blowout-proof stem
- Dual O-ring stem seal
- Adjustable packing



PRODUCT SPECIFICATIONS

Standards

- NSF/ANSI 61 and NSF/ANSI 372 (UL certified)
- Meets MSS SP-110 standards
- Sweat ends (ANSI B16.18)

ACCESSORIES (SOLD SEPARATELY)

- Lock Lever Kit (1/2"–2")
- Stem Extension Kit (1/2"–2")
- Tee Handle Kit (1/2"–1")
- Oval Handle Kit (1/2"–2")
- Memory Stop Kit (1/2"–2")
- Stainless Handle (1/2"–2")

KIT CODES

FNW 420	
PRODUCT TYPE	SIZE CODE (IN.)
Locking Handle = LHK	1/4–1/2 = BD
Stem Extension = SE	3/4–1 = FG
Tee Handle = THK	1-1/4–1-1/2 = HJ
Oval Handle = OHK	2 = K
Memory Stop = MSK	
Stainless Handle = SSHK	

Note: Figure X451 uses the same accessories as Figure 420.

Note: The Locking Handle Kit (LHK) and Stem Extension (SE) cannot be used in congruence on Figure X451.

Warning: Not for direct buried service.

FIGURE NUMBER MATRIX

FNW X451	
TRIM CODE	SIZE CODE (IN.)
Standard Trim = Blank	1/2 = D 1-1/4 = H
316 Stainless Steel = SS	3/4 = F 1-1/2 = J
	1 = G 2 = K

PRESSURE/TEMPERATURE

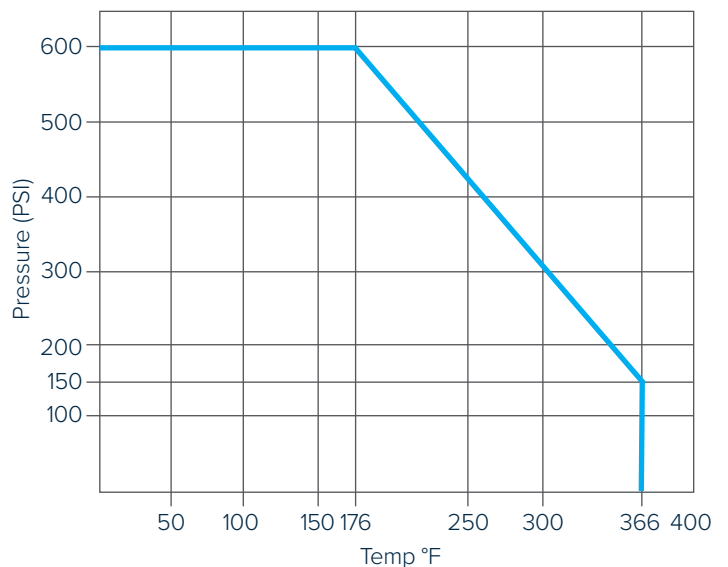

SPECIFICATIONS

FIGURE X451
FORGED BRONZE BALL VALVES



LOW-LEAD COMPLIANT 2-PC FULL PORT 600 WOG

PARTS DIAGRAM

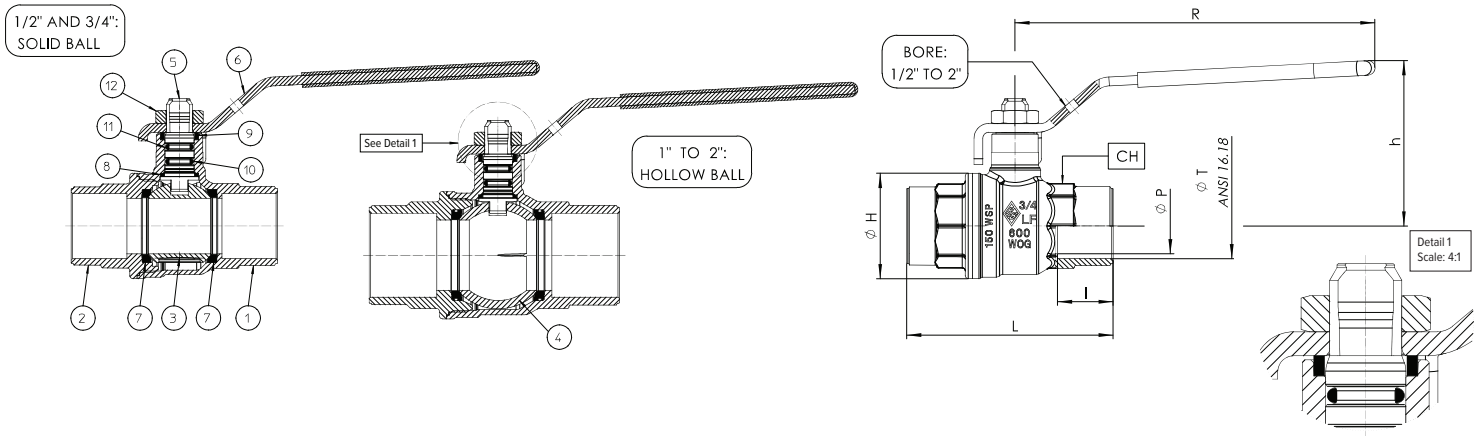

DIMENSIONS (INCHES)

Size	ø P	l	ø T	L	ø H	CH	R	h	PSI
1/2	0.55	0.50	0.63	2.19	1.22	0.87	3.78	1.77	600
3/4	0.75	0.75	0.88	2.78	1.46	1.06	4.84	2.22	600
1	0.94	0.91	1.13	3.37	1.76	1.34	4.84	2.32	600
1-1/4	1.19	0.97	1.38	3.86	2.11	1.69	5.94	2.85	600
1-1/2	1.50	1.10	1.63	4.48	2.64	1.97	5.94	3.09	600
2	1.95	1.34	2.13	5.33	3.39	2.44	6.30	3.70	600

CV & WEIGHTS

Size (in.)	Cv	FNW X451 Wt. (lbs)	FNW X451SS Wt. (lbs)
1/2	19	0.40	0.40
3/4	34	0.63	0.63
1	45	0.95	0.95
1-1/4	75	1.64	1.74
1-1/2	180	2.33	2.60
2	210	3.80	4.85

PART MATERIALS & QUANTITY

Ref #	Description	FNW X451 Material	FNW X451SS Material	Qty
1	Body	Bronze	Bronze	1
2	End Connection	Bronze	Bronze	1
3	Solid Ball 1/2" and 3/4"	Brass CW 510L (chrome-plated)	316 SS	1
4	Hollow Ball 1"-2"	Brass CW 510L (chrome-plated)	316 SS	1
5	Stem	Brass CW 510L	316 SS	1
6	Handle	Steel DD11	Steel DD11	1
7	Ball Seat	PTFE	RPTFE	2
8	Thrust Washer	PTFE	PTFE	1
9	Packing Ring	PTFE	PTFE	1
10	O-ring	NBR	NBR	1
11	O-ring	FKM	FKM	1
12	Nut	Steel CL 04	Steel CL 04	1