

EXPERIENCE THE DIFFERENCE

www.abatix.com

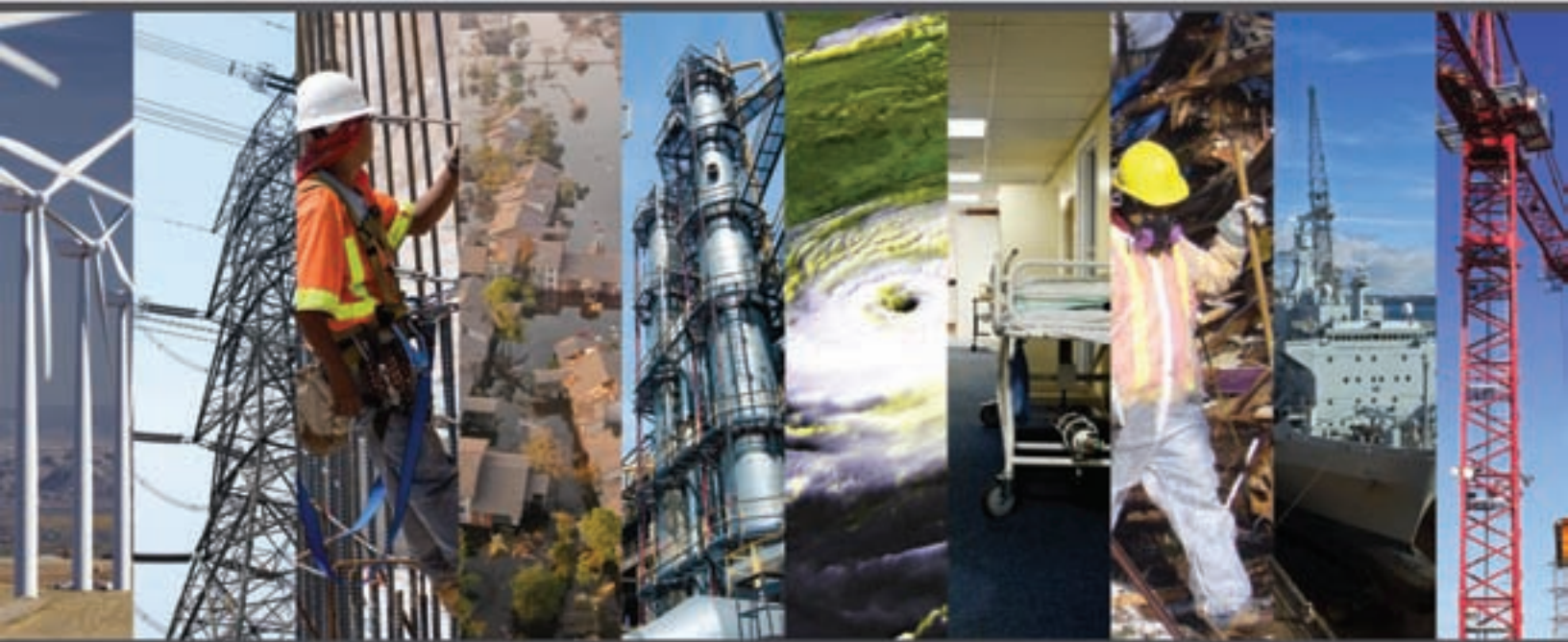

PRODUCT CATALOG

Company History

Grass Roots Business Building – With the idea that success is based on building long lasting relationships; Abatix was founded on May 16th, 1983, when we began selling industrial safety supplies. Now celebrating over 30 years of serving customers, Abatix has grown into a nationally recognized supplier of safety, environmental, construction, janitorial and industrial products, carrying thousands of products and supporting customers across the nation.

Industries Served

One Company, Many Industries – Abatix proudly serves the Fire and Water Restoration, Mold Remediation, Disaster Response, General Construction, Industrial Safety, Petrochemical, Energy, Environmental and Hospital industries.



Locations/Shipping

What You Need, When You Need It, Where You Need It – With 11 strategic locations and a team of highly knowledgeable logistics experts, Abatix will ensure your orders are delivered when and where you need them.

Ordering Simplified

Search, Click, Pay, Track 24/7/365 – Abatix' online ordering system is simple to use. Once you are registered and have a customer code, you can create orders, customize shopping lists, and view ordering history, track shipments, view and print invoices and pay bills online.



Commitment to Our Customers

One on One – We are committed to your complete satisfaction. Our goal is to ensure your orders are filled and shipped on time, every time and that your questions get answered to your satisfaction. Our success is based on a long lasting partnership, built on mutual trust.

Our Mission

Our Customers...

We will meet your needs with really, really, REALLY great service.

Our Team Members...

We will create a learning, fulfilled, supportive and progressive environment.

Our Stockholders and Team Member Owners...

We will strive to achieve the performance from which all will benefit.

Our Vendors...

We will represent your products with the highest level of knowledge and enthusiasm.

Our Community...

We will be pro-active and exemplary corporate citizens in the communities we serve.



Table of Contents

Abrasives.....3-8
Adhesives & Sealants9
Bags9-10
Batteries & Flashlights11-13
Bits14-20
Blades20-23
Cases24
Chemicals25-39
Containment40-45
Coolers & Cups.....46
Drink Mix.....46-47
Electrical Specialty48-60
Equipment.....61-79
Fans.....80
First Aid Kits81
Hand Tools.....82-124
Instrumentation125-135
Janitorial Supplies136-143
Ladders144-145
Locks.....146-147
Material Handling148-155
Plumbing & Mechanical156-166
Poly Sheeting167
Power Tools.....168-179
Protection, Eye & Face180-184
Protection, Fall.....185-195
Protection, Hand196-204
Protection, Head205-209
Protection, Hearing.....210-211
Protection, Respiratory211-218
Protective Clothing219-231
Rainwear & Boots232-233
Safety Wear.....234-237
Signs, Labels, Tags238-243
Spill Control244-253
Spray Paint254-255
Sundries.....255-258
Surface Protection259-261
Tape.....261-263
Temporary Power264-269
Reference Charts270-274

Produced by "The Catalog Group," a division of Western Catalog Group, Inc., Marthasville, Missouri.
Unauthorized reproduction of this catalog, whole or in part, is strictly prohibited.

MAX[®]

We Will Not Put the MAX Name on Just Any Product

From our famous teal tape to gloves, cleaners, spray adhesive, safety vests and coveralls, Abatix MAX branded products offer the best in value, performance and quality.



MAX Duct Tapes

From the general contractor to the maintenance shop and general purpose use, our MAX tapes have you covered. MAX tapes can be found in the "Tape" section on page 261.



MAX Heavy-Duty Adhesive Spray

Waterproof, flexible, and non-staining, our adhesive spray can be used for temporary or permanent bonds. MAX adhesive spray can be found in the "Adhesives & Sealants" section on page 9.



MAX Gloves

Keep those hands protected with MAX drivers, general purpose and work gloves. MAX gloves can be found in the "Protection, Hand" section on page 196.



MAX Pro-Clean™ Chemicals

Got a dirty job or some tough odors? MAX Pro-Clean™ cleaners, degreasers and odor control products can get the job done. MAX Pro-Clean™ can be found in the "Chemicals" section on pages 31, 32 & 33.



MAX Maxguard MP® Coveralls

MAXGUARD MP utilizes state-of-the-art lamination technology to combine a soft non-woven fabric with a microporous film. Maxguard coverall can be found in the "Protective Clothing" section on page 219.



MAX Hi-Viz Safety Vests

Get seen on the job. MAX hi-viz safety vests are available in non-rated, Class 2 and Class 3 styles in orange or green. MAX safety vests can be found in the "Safety Wear" section on page 234.

EXPERIENCE THE DIFFERENCE

Abrasives - Cup Wheels

Segmented Turbo Cup Wheels Wet or Dry



Segmented Turbo Cup Wheels have recently become more popular due in part to greater surface coverage per pass, and as well as the smooth finish they provide at the slab or work area. This style cup wheel has also become the tool of choice for use on surface overlayment material such as epoxy and mastics.

GOOD

Item# **LMDSPPSTC4N18** 4" x 5/8"-11, Threaded Nut
 Item# **LMDSPPSTC7N24** 7" x 5/8"-11, Threaded Nut

Double Row Cup Wheels Wet or Dry



The double row design provides a smoother finish, better debris removal versus the standard single row configuration. While also providing a more stable grinding platform, which helps prevent "gouging" often seen in the single row variety. Wrench flats aid in easy removal once the job is done.

GOOD

Item# **LMDSPPGC4DN** 4" x 5/8"-11, Threaded Nut
 Item# **LMDSPPGC7DN** 7" x 5/8"-11, Threaded Nut

Concrete and Masonry Cup Wheels

Pearl's diamond cup wheels are designed for grinding a wide variety of material. They are all engineered for heavy-duty grinding, aggressive stock removal with extreme life. Pearl's cup wheels are developed with high quality control standards you have come to expect from Pearl. These cup wheels are excellent for use on concrete, brick, block, marble, granite natural stone and much more.



P2 PRO-V™ CUP WHEELS Double Row

Concrete, Block, Stone and Other Masonry Products.



Heavy-duty, wet or dry grinding cup wheel. Two rows of diamond segments.

PT. NUMBER	SPECS	MAX RPM
PV04CDH	4 x 5/8-11	13,700
PV07CDH	7 x 5/8-11	8,500

Don't see what you are looking for? Ask your Abatix Sales Representative. Abatix carries tens of thousands of products. **We will make sure you get what you need, when you need it, where you need it.**

Abrasives - Cut-Off Wheels

TYPE 1 - Thin High Speed Cut-off Wheels

Abrasives



A24R - General Purpose

- Aluminum oxide grain.
- General purpose, **long life**.

METAL Ferrous metals (iron, steel, welds, etc.)

A36T - Fast Cutting

- Aluminum oxide grain.
- Hard bond for **aggressive cutting on rough applications**.

METAL Ferrous metals (iron, steel, welds, etc.)

STAINLESS Stainless steel

A60S

- Thin **.045** width.
- Use with reusable 5/8-11 adaptor to fit angle grinders.
- **Extremely fast cutting with long life.**

METAL Ferrous and/or non-ferrous metals (iron, steel, welds, etc.)

A60T - Burr Free

- **Hard bond for smooth cutting.**
- For use in **nuclear, aerospace, automotive, foundry industries and plant maintenance.**

METAL Ferrous metals (iron, steel, welds, etc.)

STAINLESS High tensile metals

A Dia.	Size		Max RPM	Grades Available Part Numbers			Qty. Per Box	Qty. Per Ctn.	Lbs. Per Box	
	B Width	C Bore		A24R	A36T	A60S				A60T
2	1/16	1/4	30,558	-	23004	-	23005	50	50	1
2	1/16	3/8	30,558	-	23002	-	23003	50	50	1
2	.035	1/4	30,558	-	23012	-	23013	100	100	1
2	.035	3/8	30,558	-	23010	-	23011	100	100	1
2-1/2	1/16	1/4	24,446	-	23022	-	23023	50	50	2
2-1/2	1/16	3/8	24,446	-	23020	-	23021	50	50	2
2-1/2	.035	1/4	24,446	-	23032	-	23033	100	100	2
2-1/2	.035	3/8	24,446	-	23030	-	23031	100	100	2
3	1/16	1/4	25,000	-	23042	-	23043	50	50	3
3	1/16	3/8	25,000	-	23040	-	23041	50	50	3
3	.035	1/4	25,000	-	23052	-	23053	100	100	3
3	.035	3/8	25,000	-	23050	-	23051	100	100	3
3	1/8	3/8	20,372	23060	-	-	-	25	100	2
4	1/16	1/4	19,000	-	23067	-	23068	50	50	5
4	1/16	3/8	19,000	-	23065	-	23066	50	50	5
4	1/16	5/8	19,000	-	23061	-	23062	50	50	5
4	.035	1/4	19,000	-	23071	-	23072	100	100	5
4	.035	3/8	19,000	-	23069	-	23070	100	100	5
4	.035	5/8	19,000	-	23063	-	23064	100	100	5
4	.045	5/8	19,000	-	-	23099	-	50	200	4
4	1/8	3/8	15,278	23075	-	-	-	25	100	4



A Dia.	Size		Max RPM	Grades Available Part Numbers			Qty. Per Box	Qty. Per Ctn.	Lbs. Per Box
	B Width	C Bore		A36T	A60S	A60T			
4-1/2	.045	7/8	13,300	-	23101	-	50	200	4
5	.045	7/8	12,200	-	23103	-	50	200	2
6	1/16	1/2	10,186	23202	-	23203	50	50	8
6	1/16	5/8	10,186	23200	-	23201	50	50	8
6	.035	1/2	10,186	23206	-	23207	50	50	5
6	.035	7/8	10,186	23210	-	23211	50	50	5
6	.035	5/8	10,186	23204	-	23205	50	50	5
6	.045	5/8	10,200	-	23105	-	50	200	4
6	.045	7/8	10,200	-	23106	-	50	200	4
7*	1/16	1-1/4	8,732	23250	-	23251	50	50	12
7	1/16	5/8	8,732	23265	-	23266	50	50	6
7*	.035	1-1/4	8,732	23252	-	23253	50	50	4
7	.045	5/8	8,500	-	23107	-	50	200	4
8	1/16	5/8	7,640	23275	-	23276	50	50	7
8*	1/16	1-1/4	7,640	23277	-	23278	50	50	7

*These sizes are typically used for tool room applications.

QT Quick Tip
Try .045 sizes for longer life and better value.

Abrasives - Cut-Off & Chop Saw Wheels



TYPE 1 - Portable Saw Cut-off Wheels



Size			Max RPM	Grades Available Part Numbers		Qty. Per Box	Qty. Per Ctn.	Lbs. Per Box
A Dia.	B Width	C Bore		A24R	SAIT Pro			
12	1/8	1	6,300	23410	23414	10	50	13
12	1/8	20mm	6,300	23420	23421	10	50	14
14	1/8	1	5,400	23450	24135	10	20	19
14	1/8	20mm	5,460	23455	24140	10	20	24
16	1/8	1	4,800	23459	-	10	20	30

A24R - General Purpose

- Aluminum oxide grain.
- Consistent performance, **long life.**

METAL Ferrous metals (steel, angle iron, rebar)

SAIT Pro - Metal

- Aluminum oxide grain.
- **Best value for a fast cut.**

METAL Ferrous metals

14" (20mm) with higher RPM rating for STIHL saws

All 14" and 16" portable wheels are formulated for high powered saws.



Size			Max RPM	Part Numbers		Qty. Per Box	Qty. Per Ctn.	Lbs. Per Box
A Dia.	B Width	C Bore		SAIT Pro	C24R			
12	1/8	1	6,300	23418	23413	10	50	12
12	1/8	20mm	6,300	23427	23423	10	50	12
14	1/8	1	5,400	24122	23451	10	20	16
14	1/8	20mm	5,460	24127	23456	10	20	15
16	1/8	1	4,800	-	23461	10	20	30
16	1/8	20mm	4,800	-	23466	10	20	30

SAIT Pro - Concrete

- Silicon carbide grain.
- **Best value for a fast cut.**

CONCRETE Stone, brick, soft aggregate, masonry, concrete

C24R - Concrete

- Silicon carbide grain.
- **Long life.**

CONCRETE Stone, brick, soft aggregate, masonry, concrete, schedule 40 and schedule 80 PVC pipe

14" (20mm) with higher RPM rating for STIHL saws

TYPE 1 - Chop Saw Wheels



Size			Max RPM	Part Numbers Z-Tech	Qty. Per Box	Qty. Per Ctn.	Lbs. Per Box
A Dia.	B Width	C Bore					
14	3/32	1	4,400	24414	10	20	16
16	3/32	1	3,700	24416	10	20	23

Z-tech - High Performance

- Special zirconium grain formula.
- **Fast, non-binding cutting.**

METAL Ferrous metals

STAINLESS Stainless steel, high tensile alloys



Abrasives - Fiber Discs & Grinding

TYPE 27 - Depressed Center Wheels



A24N - Fast Grinding

- Aluminum oxide grain.
- Soft bond for fast stock removal.

METAL Ferrous metals (iron, steel, welds, etc.)

STAINLESS Low grade stainless steel

A24R - Long Life

- Aluminum oxide grain.
- For general purpose grinding.
- Longer life for fewer wheel changes.

METAL Ferrous metals (iron, steel, welds, etc.)



A Dia.	B Width	C Bore	Max RPM	Grades Available Part Numbers			Qty. Per Box	Qty. Per Ctn.	Lbs. Per Box
				A24N	A24R	A24T			
3	3/16	3/8	18,000	20001	-	-	25	100	3
3	1/4	3/8	18,000	20002	20005	-	25	100	4
4	3/16	3/8	13,500	20010	-	-	25	100	6
4	1/4	3/8	13,500	20012	20019	-	25	100	7
4	1/4	5/8	13,500	20015	20013	-	25	100	7
4-1/2	3/16	7/8	13,300	20050	-	-	25	100	8
4-1/2	3/16	5/8-11	13,300	20150	-	-	10	40	5
4-1/2	1/4	7/8	13,300	20060	20063	20065	25	100	9
4-1/2	1/4	5/8-11	13,300	20160	20163	20165	10	40	6
5	1/4	7/8	12,200	20070	20073	20075	25	100	11
5	1/4	5/8-11	12,200	20170	20173	20175	10	40	6
6	1/4	7/8	10,200	20078	20079	20280	25	50	18
6	1/4	5/8-11	10,200	20178	20076	20180	10	40	10
7	1/4	7/8	8,500	20081	20080	20285	25	50	24
7	1/4	5/8-11	8,500	20085	20086	20185	10	40	14
9	1/4	7/8	6,600	20091	20090	20295	25	50	42
9	1/4	5/8-11	6,600	20095	20096	20195	10	40	20

A24T - Edge Grinding

- Aluminum oxide grain.
- Hard bond designed for edge and bevel grinding and other applications where a harder wheel is preferred.
- Longer life for fewer wheel changes.

METAL Ferrous metals (iron, steel, welds, etc.)

QT Quick Tip
The "softer" a grinding wheel is (A24N) the faster it will remove metal.



C24N - Concrete

- Silicon carbide grain.
- Soft bond for fast stock removal.

CONCRETE Masonry, concrete, stone

METAL Cast iron and other ferrous metals.

QT Quick Tip
Use the C24N wheel on hard to grind metal.

A Dia.	B Width	C Bore	Max RPM	Part Numbers	Qty. Per Box	Qty. Per Ctn.	Lbs. Per Box
				C24N			
4	1/4	5/8	13,500	20017	25	100	6
4-1/2	1/4	7/8	13,300	20061	25	100	8
4-1/2	1/4	5/8-11	13,300	20161	10	40	6
5	1/4	7/8	12,200	20071	25	100	10
5	1/4	5/8-11	12,200	20171	10	40	6
7	1/4	7/8	8,500	20082	25	50	24
7	1/4	5/8-11	8,500	20087	10	40	12
9	1/4	7/8	6,600	20092	25	50	33
9	1/4	5/8-11	6,600	20097	10	40	7

THE ULTIMATE COMBO™

- 4 in 1 1) cut, 2) notch, 3) debur, 4) light grind



A60S - General Purpose

Size		Max RPM	Part No. Type 27
Dia.	Width Bore		
4-1/2	.095 7/8	13,300	22320
4-1/2	.095 5/8-11	13,300	22420
5	.095 7/8	12,200	22325

Z-Tech™ - High Performance

Size		Max RPM	Part No. Type 27
Dia.	Width Bore		
4-1/2	.095 7/8	13,300	22330
4-1/2	.095 5/8-11	13,300	22430
5	.095 7/8	12,200	22335

FIBER DISCS - 2A

- Aluminum oxide grain.
- General purpose.
- Closed coat structure for more material removal, better finishing.

METAL Ferrous and/or non-ferrous metals

WOOD Wood



Size	Grit	Part No. 2A (100 pieces)
4-1/2 x 7/8	16	51022
4-1/2 x 7/8	24	51024
4-1/2 x 7/8	36	51036
4-1/2 x 7/8	50	51050
4-1/2 x 7/8	60	51060
4-1/2 x 7/8	80	51080
4-1/2 x 7/8	100	51100
4-1/2 x 7/8	120	51120

EXPERIENCE THE DIFFERENCE

Abrasives - Grinding & Cutting

UNITED
ABRASIVES, INC.

SAIT

ENCORE - High Performance Flap Disc



- More flaps that are larger yield longer life.
- Made with premium zirconium abrasive material which provides long-life and high stock removal.
- Will not contaminate stainless steel.
- Grind, blend and finish with one product.
- Out performs competitive regular density flap discs.
- Resists loading on aluminum – unique in the industry.

For use on: **METAL** **STAINLESS** **ALUMINUM**

OVATION® - High Density Flap Disc

The Original



- Heavy-duty for tougher applications.
- High pressure is ideal for removing deeper scratches from the work surface.
- Made with premium zirconium abrasive material which provides long-life and high stock removal.

For use on: **METAL**
STAINLESS

OVATION® ATTACKER®



- Conformability – a softer cushioned design that is ideal on irregular surfaces.
- Flap design allows the use of light pressure to produce the perfect finish.
- Specially designed abrasive flaps which provide aggressive cutting action.

For use on: **METAL**
STAINLESS
ALUMINUM

THE ULTIMATE CUT™

Extra long life on stainless steel

Type 1



- Best in Class – cutting **STAINLESS**
- Exceptional cutting performance on

METAL **ALUMINUM**

Size			Max RPM	Part Numbers	
Dia.	Width	Bore		Type 1	Type 27
4-1/2	.045	7/8	13,300	22230	22380
5	.045	7/8	12,200	22235	22385
6	.045	7/8	10,200	22240	22390

Type 27

Z Premium Zirconium

Size		Grit	Encore		Ovation® Part No.	Ovation® Attacker® Part No.
Dia.	Arbor		Type 27 Part No.	Type 29 Part No.		
4-1/2	7/8	36	71205	79105	78005	—
4-1/2	7/8	40	71206	79106	78006	76206
4-1/2	7/8	60	71208	79108	78008	76208
4-1/2	7/8	80	71209	79109	78009	76209
4-1/2	7/8	120	71211	79111	78011	76211
4-1/2	5/8-11	36	71215	79115	78105	—
4-1/2	5/8-11	40	71216	79116	78106	76316
4-1/2	5/8-11	60	71218	79118	78108	76318
4-1/2	5/8-11	80	71219	79119	78109	76319
4-1/2	5/8-11	120	71221	79211	78111	76321
5	7/8	36	71225	79125	78025	—
5	7/8	40	71226	79126	78026	76226
5	7/8	60	71228	79128	78028	76228
5	7/8	80	71229	79129	78029	76229
5	7/8	120	71231	79131	78031	76231
5	5/8-11	36	71235	—	78125	—
5	5/8-11	40	71236	—	78126	76336
5	5/8-11	60	71238	—	78128	76338
5	5/8-11	80	71239	—	78129	76339
5	5/8-11	120	71241	—	78131	76341
6	7/8	36	—	71245	78035	—
6	7/8	40	—	71246	78036	76236
6	7/8	60	—	71248	78038	76238
6	7/8	80	—	71249	78039	76239
6	7/8	120	—	71251	78041	76241
6	5/8-11	36	—	71255	78135	—
6	5/8-11	40	—	71256	78136	76346
6	5/8-11	60	—	71258	78138	76348
6	5/8-11	80	—	71259	78139	76349
6	5/8-11	120	—	71261	78141	76351
7	7/8	36	—	71265	78045	—
7	7/8	40	—	71266	78046	76246
7	7/8	60	—	71268	78048	76248
7	7/8	80	—	71269	78049	76249
7	7/8	120	—	71271	78051	76251
7	5/8-11	36	—	71275	78145	—
7	5/8-11	40	—	71276	78146	76356
7	5/8-11	60	—	71278	78148	76358
7	5/8-11	80	—	71279	78149	76359
7	5/8-11	120	—	71281	78151	76361

Specialty Pipeline Wheel

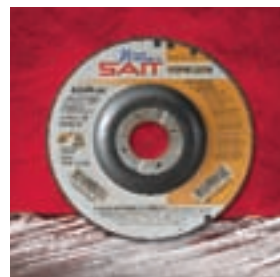

A24R Pipeline - Long Life

- Aluminum oxide grain.
- For the pipeline industry.
- Designed and manufactured to perform both cutting and light grinding.
- Long Life.

METAL Ferrous metals (steel, cast iron, etc.)

Size			Max RPM	Part No. Pipeline
Dia.	Width	Bore		
4-1/2	1/8	7/8	13,300	22030



Abrasives - Wire Wheels & Brushes

Roughneck® Knot Wire Wheels – The individual knot wire tufts of a knot wheel provide minimal flexibility for more aggressive brushing action. Weiler's knot wheels are constructed with an internal steel plate that has equally spaced individual holes around the perimeter. Wire is inserted through each hole and twisted into a knot. Each hole has precisely the same wire count, thereby assuring perfect balance. This eliminates vibration, reduces operator fatigue and increases brush life.

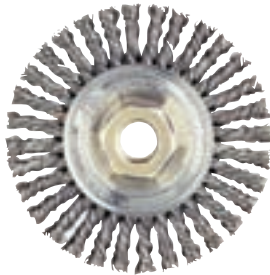

Applications

- ✓ Weld cleaning.
- ✓ Removing rust, scale, weld spatter and oxidation.
- ✓ Roughening surfaces.
- ✓ Removing rubber or plastic flash.
- ✓ Heavy burr removal.
- ✓ Heavy-duty cleaning operations.
- ✓ Surface conditioning.

Stringer Bead Twist Wheels – Narrow Face
For hard-to-reach areas; primarily for weld cleaning.

Dia.	Wire Size	Arbor Hole	No. of Knots	Face Width	Trim Length	Thickness at Face Plates	Max. RPM	Ref. Code	Item No.	
									Steel	Stainless
4"	.020	5/8"-11 UNC	32	3/16"	7/8"	7/16"	20,000	STBA-432	13131	13138

Stem-Mounted Brushes – Weiler's brushes are permanently mounted on 1/4" steel stems, providing quick installation on chuck or collet. High RPM ratings provide faster finishing for the lowest cost-per-piece brushed.



Applications

- ✓ Cleaning and finishing recessed areas or I.D.s.
- ✓ Die, mold and tool cleaning and polishing.
- ✓ Rubber and plastic flash removal.
- ✓ Rust and paint removal.
- ✓ Scale and slag removal.
- ✓ I.D. Pipe cleaning.
- ✓ Carbon cleaning.
- ✓ Weld cleaning.
- ✓ Deburring.
- ✓ Spot facing.

Knot Wire End Brushes – Hollow End
Rugged knot-type construction provides aggressive, high-impact action for severe applications.

Dia.	Wire Size	Trim Length	Max. RPM	Ref. Code	Item No. Steel
1-1/8"	.020	7/8"	22,000	EBB-41	10028

Cup Brushes – For use on large, flat surface areas, Weiler cup brushes provide fast, heavy-duty brushing action. Designed for use on production equipment, angle grinders and portable power tools, our cup brushes are available in several diameters.



Applications

- ✓ Heavy-duty cleaning of large metal surfaces.
- ✓ Cleaning prior to welding.
- ✓ Weld scale and corrosion removal.
- ✓ Rust and paint removal.
- ✓ Roughening.
- ✓ Deburring.

Knot Wire Cup Brushes – Single Row - General Duty
For fast, efficient cleaning of large surfaces.

Dia.	Wire Size	Arbor Hole	Trim Length	Max. RPM	Ref. Code	Item No. Steel
2-3/4"	.020	5/8"-11 UNC	1"	14,000	SRA-2	13286
4"	.023	5/8"-11 UNC	1-1/4"	10,200	SR-4	12316
6"	.023	5/8"-11 UNC	1-5/8"	6,000	SRF-6	12856

Crimped Wire Wheels – These wheels are highly flexible and are ideal for light to medium duty surface preparation on irregular surfaces. Weiler's solid ring construction ensures smooth brushing action and long brush life. Our crimped wire wheels are densely filled with high quality fill materials including heat-treated steel and Type 302 stainless steel.



Applications

- ✓ Cleaning rust, scale and dirt.
- ✓ Light deburring.
- ✓ Edge blending.
- ✓ Roughening for adhesion.
- ✓ Finish preparation prior to plating or painting.
- ✓ Finishing for appearance.
- ✓ Ideal for high production applications.

Crimped Wire Wheels – Narrow Face
Flexible brushing action. Can be mounted in multiples.

Dia.	Wire Size	Arbor Hole	Face Width	Trim Length	Thickness at Face Plates	Max. RPM	Ref. Code	Item No.	
								Steel	Stainless
4"	.014	5/8"-11 UNC	1/2"	7/8"	7/16"	14,000	TLNA-4	13081	13085

EXPERIENCE THE DIFFERENCE

Adhesives & Sealants

HEAVY-DUTY SPRAY ADHESIVE



This wide web spray pattern aerosol adhesive is suitable for your toughest adhesive applications with materials such as leather, cardboard, most plastics and cloth. It is ideal for uneven or porous surfaces. Max Heavy-Duty Spray Adhesive does not contain chlorinated solvents or ozone depleters.

Features

- Nonchlorinated web spray formula with high solids.
- Fast tack, quick adhesion for temporary or permanent bonds.
- Waterproof and non-staining.
- Flexible and non-dimpling.
- Hexane free formula.

Item# **AMRLMH17**

Quick Cure Polyurethane Foam Sealant

A fast and easy, high-yield means to seal cracks and gaps. Patented all-direction dispensing easily maneuvers tight spots. Reusable dispensing means you can restart the can later.



Product # **4004521212** (12 oz.)

Product # **4004521224** (24 oz.)

- Yield (linear feet)
 - 12 Oz., 1/4" bead - 918, 3/8" bead - 408
 - 24 Oz., 1/4" bead - 1805, 3/8" bead - 818
- Density - 1.3-1.8 lbs./cu. ft.
- R value - 4-5 per inch thickness.
- Max. service temp for cured foam - 240°F (116°C).
- Shelf life - 24 months.
- Flame spread - 10, smoke developed - 15.
- ICC-ESR-1926

Poly-Clean Polyurethane Foam Cleaner

Poly-Clean easily cleans uncured foam from hands, tools and applicator guns. Attach directly to the gun basket to flush barrel.

Product # **4004712000** (12 oz.)

- DO NOT apply to furniture or any other finished surface.



Insert attached adaptor into valve opening and press to dispense a small amount of Poly-Clean to a cloth for cleaning hands, tools and gun baskets.

Attach Poly-Clean can to your gun and spray as you would any gun foam to thoroughly clean your applicator gun.

Gun Foam II Polyurethane Foam Sealant

An ICC code complying fireblock penetration sealant suitable for Type V residential constructions. The bright orange color alerts building inspectors that this foam has been tested with modified ASTM-814 and UL-1715 and evaluated by ICC-ES (ESR-1926).

Withstands flaming over twice as long as the leading competitor, lending crucial seconds to dangerous situations. Gun Foam II is not a firestop.

Product # **4004528712** (24 oz.)

- Yield (linear feet)
 - 24 Oz., 1/4" bead - 2096
- Density - 1.3-1.8 lbs./cu. ft.
- R value - 4-5 per inch thickness.
- Max. service temp for cured foam - 240°F (116°C).
- Shelf life - 18 months.
- Flame spread - 15, smoke developed - 25.
- ICC-ESR-1926



Sharpshooter-X

Product # **4004510608**

- Reusable gun features a metal barrel and adjustable output.



Bags - Asbestos Bags

ASBESTOS LABELED BAGS

Item#	Size	Mil	Color	Qty.
BAGAB63040C	30" x 40"	6	Clear	100/roll
BAGAB63350C	33" x 50"	6	Clear	75/roll
BAGAB63350Y-BX	33" x 50"	6	Yellow	75/box

Bags - Debris

GENERAL DEBRIS BAGS



Item#	Size	Mil	Color	Qty.
BAGCB-32	33" x 48"	3	Black	32/box
BAG33350C	33" x 50"	3	Clear	75/roll
BAG63040C	30" x 40"	6	Clear	100/roll
BAG63350C	33" x 50"	6	Clear	75/roll
BAG63860C	38" x 60"	6	Clear	50/roll



Bags - Glovebags

AVAIL EXTENDED RUN GLOVEBAGS



The Avail Extended Run glovebag revolutionized the way the glovebags are used. The "chain bag" that allows extended sections of insulation to be contained in one operation dramatically increases productivity and safety by eliminating multiple bag set-up time and reducing jobsite fiber counts. The Extended Run glovebags are designed to be used in sections of 2 to 25 chambers at a time.

- Item# **GRAEXT4460-25** The basic Extended-Run glovebag. This economy model glovebag has all the features of the Avail line with the exception of entry ports. The bag is designed for pipe up to 8" in diameter and will safely provide a horizontal work area of approximately 24" per chamber.
- Item# **GRAEXT6072-20** The GRAEXT6072-20 Extended-Run glovebag will enclose pipe diameters up to 14" and create a work area of about 40" per chamber.
- Item# **GRAEXT6684-2-15** The GRAEXT6684-2-15 Extended-Run glovebag will enclose pipe diameters up to 18" and create a work area of about 40" per chamber.

AVAIL SINGLE GLOVEBAGS

The traditional glovebag for repair and maintenance activities or "wrap-and-cut" removal projects. Smart design details such as quick attach collars, fiberguard glovesleeves and arm openings placed so the weight of debris does not rest on the worker make these bags the number one choice of abatement professionals.



This super sized model is for 30" diameter pipes, valves or unique situations where smaller, standard bags just don't fit the task.

Item# **GRAS72120-2**

AVAIL QUICKTWIST GLOVEBAGS

The QuickTwist design has two distinct work zones, the removal area and the debris chamber. This two-stage design makes it safer and easier for workers to remove and securely separate debris-laden bags from pipe without having to slide the bag or put any stress on the secured ends of the glovebag.



The GRAQT10 is the most popular glovebag in the collection. The GRAQT10 fits pipe diameters up to 10" and safely allows for a horizontal work area of approximately 48".

Item# **GRAQT10**



When larger diameters of pipe are encountered, the GRAQT14 is the next choice. It safely encloses pipe diameters from 10" to 14" and allows up to 60" of work area.

Item# **GRAQT14**



The GRAQT18 is designed for pipe diameters from 14" to 18" and provides a work area of approximately 66". The GRAQT18 incorporates 2 sets of glovesleeves for access to both sides of the pipe.

Item# **GRAQT18**



The GRAQT30 glovebag handles pipe diameters from 18" to 30" and allows for up to 70" of horizontal work area. The GRAQT30 incorporates 3 sets of glovesleeves to access the complete workarea comfortably.

Item# **GRAQT30**

EXPERIENCE THE DIFFERENCE

Batteries & Flashlights

9V ALKALINE BATTERIES – Shrink-Wrapped 6-Pack



- Rayovac Ultra Pro is the #1 selling industrial battery based on top industrial distributors. Lasts as long as Energizer Max.
- Specially engineered for professional use.
- Conveniently shrink-wrapped to minimize packaging.
- Guaranteed fresh for 5 years / Best used before date on battery.
- Mercury free formula.

Item# **RAYAL9V**

AA ALKALINE BATTERIES – Shrink-Wrapped 8-Pack



- Rayovac Ultra Pro is the #1 selling industrial battery based on top industrial distributors. Lasts as long as Energizer Max.
- Specially engineered for professional use.
- Conveniently shrink-wrapped to minimize packaging.
- Guaranteed fresh for 7 years / Best used before date on battery.
- Mercury free formula.

Item# **RAYALAA**

AAA ALKALINE BATTERIES – Shrink-Wrapped 8-Pack



- Rayovac Ultra Pro is the #1 selling industrial battery based on top industrial distributors.
- Specially engineered for professional use.
- Conveniently shrink-wrapped to minimize packaging.
- Guaranteed fresh for 7 years / Best used before date on battery.
- Mercury free formula.
- Rayovac lasts as long as Duracell Coppertop and Energizer Max.

Item# **RAYALAAA**

Flashlights

2D FLASHLIGHT WITH RING HANGER



- Smooth beam with prismatic reflector for close-in use. / Standard bulb.
- Tough polypropylene body with barrier wall and bulb support system.
- Robust tool-yellow color/texture.
- Protected slide switch.
- Consumer preferred comfort grip.
- Extra tough hanging ring.
- Impact resistant to 7 feet.
- Water, chemical, oil and gas resistant.
- Lifetime warranty / Runs on 2 D batteries.

Item# **RAYIN2**

C ALKALINE BATTERIES – Shrink-Wrapped 6-Pack



- Rayovac Ultra Pro is the #1 selling industrial battery based on top industrial distributors.
- Specially engineered for professional use.
- Conveniently shrink-wrapped to minimize packaging.
- Guaranteed fresh for 7 years / Best used before date on battery.
- Mercury free formula.
- Rayovac lasts as long as Energizer Max.

Item# **RAYALC**

D ALKALINE BATTERIES – Shrink-Wrapped 6-Pack



- Rayovac Ultra Pro is the #1 selling industrial battery based on top industrial distributors.
- Specially engineered for professional use.
- Conveniently shrink-wrapped to minimize packaging.
- Guaranteed fresh for 7 years / Best used before date on battery.
- Mercury free formula.
- Rayovac lasts as long as Duracell Coppertop and Energizer Max.

Item# **RAYALD**

6-VOLT BATTERIES – Spring Terminals, General Purpose



- Built to exceed performance demands of industrial applications.
- Mercury and Cadmium free.
- Guaranteed against leakage.
- Environmentally safe - meets EPA requirements for landfill disposal.

Item# **RAY6V-GP**

3 IN 1 LED HEAD-LITE



- 2900 Peak beam candlepower.
- New LED technology runs 20 times longer.
- 2 Red LED's for improved "Night Vision" – LED's never need to be replaced.
- 1 Super bright white LED for close in viewing / Low beam.
- Long range T3 Krypton bulb with "spot to flood" focus.
- 2-way adjustable head strap.
- Pivoting adjustment.
- Withstands 5-foot drop tests / Weatherproof.

Item# **RAYSPHLTLED-B**



Flashlights



PELILITE™ 1800 FLASHLIGHT

This one is built to last. The unbreakable ABS body resists chemicals, water and corrosion. The polycarbonate lens and focused Xenon lamp module produce a tight white beam that penetrates smoke and fog. The PeliLite 1800 flashlight is submersible, thanks to the o-ring seal and twist-on shroud that eliminates leaky switches. It is powered by 2 C alkaline cells.

- Item# **PEL1800CBK** Black
- Item# **PEL1800COR** Orange
- Item# **PEL1800CYL** Yellow

Batteries not included



SABRELITE™ 2000 FLASHLIGHT

This powerful flashlight was designed with one thing in mind: SAFETY. It carries more approvals than any other flashlight on the market today, making it safe for any hazardous environment or condition. The SabreLite is o-ring sealed with a twist-on shroud and comes with a polarity battery guard tray that safeguards against dangerous "outgassing" of hydrogen from an accidentally reversed cell. It is powered by 3 C alkaline cells, submersible, and has an ABS resin body which resists chemicals, corrosion and extreme temperatures. Unlike ordinary flashlights that produce a yellow beam, the SabreLite's incredibly bright Xenon lamp produces a powerful collimated white beam. Pelican's SabreLite is the leader in quality and performance.

- Item# **PEL2000CBK** Black
- Item# **PEL2000COR** Orange
- Item# **PEL2000CYL** Yellow

Batteries not included



SabreLite™ 2000 Lamp
PEL2004 - Xenon bulb for
 PEL2000C



SABRELITE™ 2010 RECOIL™ LED FLASHLIGHT

The SabreLite 2010 Recoil LED is Pelican's flagship LED flashlight. Recoil LED Technology produces a white collimated beam that's as bright as an incandescent flashlight and provides 10,000 hours of lamp life and extended battery burn time. The rugged, light weight ABS resin body is submersible and a twist on/off lens shroud eliminates accidental discharge. It is powered by 3 C alkaline cells. The SabreLite 2010 Flashlight is the future of LEDs.

- Item# **PEL2010CBK** Black
- Item# **PEL2010CYL** Yellow

Batteries not included



STEALTHLITE™ 2410 RECOIL™ LED FLASHLIGHT

The Recoil LED module produces a true, bright collimated LED beam. The 2410 is corrosion proof, resistant to extreme temperatures, and submersible. Popular with firefighters and adventure seekers. The unique easy slide thumb switch on the StealthLite 2400 Flashlight is easy to operate, even with gloves. The Xenon lamp is powered by 4 AA alkaline cells for a bright beam that penetrates thick smoke, fog and dust. Attach the StealthLite to one of our optional helmet light holder clips and you have a hands-free light for work or play.

- Item# **PEL2410CBK** Black
- Item# **PEL2410CYL** Yellow

4 AA alkaline batteries included

Flashlights



HEADSUP LITE™ 2620 FLASHLIGHT

A hybrid LED/Xenon hands-free flashlight. The 2620 gives you the option of using the Xenon lamp for intense bright light or 3 LEDs to conserve battery life. The multi-angle pivoting head allows you to aim light where you need it. A rubber strap for hard hat use and adjustable cloth strap for bare head use are both included. The HeadsUp Lite 2620 is perfect for hiking, camping or for any task that require both hands. Powered by 3 AAA alkaline cells.

Item# **PEL2620C** Black
3 AAA alkaline batteries included



HEADSUP LITE™ 2690 LED FLASHLIGHT

Regardless of the season, Pelican's new 2690 HeadsUp Lite™ won't leave you in the dark. With 60 lumens of LED light, 10 hours of battery burn time and weighing in at 4.1 ounces, it's brighter, more efficient, compact and lighter than other headlamps in its class. The no-nonsense rotary bezel switch is easy to operate, even when wearing bulky gloves.

The 2690 is made of impact and chemical resistant ABS and it's water resistant for all-weather use. It comes with an adjustable and comfortable cloth strap, as well as a heavyduty rubber strap that will not slip off your climbing helmet.

Pelican's new 2690 HeadsUp Lite™ is engineered for those who take the outdoors seriously.

Use your head. Get the 2690 HeadsUp Lite™ from Pelican.

Item# **PEL2690** Black
3 AAA alkaline batteries included



LITTLE ED™ 3610 RECOIL™ LED FLASHLIGHT

The 3610 uses a 1 watt LED that's aimed backwards into the reflector. 100% of the light is captured and aimed forward as a tight collimated beam that's as bright as an incandescent. The body is made of tough ABS resin that's corrosion proof and resistant to extreme temperatures. It is powered by 4 AA alkaline cells.

Item# **PEL3610CBK** Black
Item# **PEL3610CYL** Yellow
4 AA alkaline batteries included



BIG ED™ 3700 FLASHLIGHT

Designed for the firefighter, the Big Ed is the choice of flashlight for the turnout gear. The unbreakable ABS body resists chemicals, water and corrosion. Rubber side grips prevent slipping and the push button switch on the side is easy to operate, even with thick gloves. For hands-free use, a heavyduty stainless steel clip is built in. The 3700 uses a hi-intensity Xenon lamp that produces a beam strong enough to cut through thick smoke and dust. A back-up emergency lamp is housed behind the reflector. Battery replacement is easy with its quick change battery ejection system. The Big Ed is powered by 4 C alkaline cells.

Item# **PEL3700B** Yellow
Batteries not included



Bits - Jobber Length Drill Bits

Heavy-Duty Black Oxide Coated High Speed Steel Jobber Length Drill Bits



- Bit is constructed of M-2 high speed steel for the best combination of strength, heat resistance and wear resistance.
- For general use in wood, metal and plastic.
- Black oxide coating resists corrosion.
- 135-Degree split point ensures a true start and eliminates bit walking.

Item No.	Size	Twist Length	Overall Length
63503	3/64"	3/4"	1-3/4"
63504	1/16"	7/8"	1-7/8"
63505	5/64"	1"	2"
63506	3/32"	1-1/8"	2-1/4"
63507	7/64"	1-1/2"	2-5/8"
63508	1/8"	1-5/8"	2-3/4"
63509	9/64"	1-3/4"	2-7/8"
63510	5/32"	2"	3-1/8"
63511	11/64"	2-1/8"	3-1/4"
63512	3/16"	2-5/16"	3-1/2"
63513	13/64"	2-7/16"	3-5/8"
63514	7/32"	2-1/2"	3-3/4"
63515	15/64"	2-5/8"	3-7/8"
63516	1/4"	2-3/4"	4"
63517	17/64"	2-7/8"	4-1/8"
63518	9/32"	2-15/16"	4-1/4"
63519	19/64"	3-1/16"	4-3/8"
63520	5/16"	3-3/16"	4-1/2"
63521	21/64"	3-5/16"	4-5/8"
63522	11/32"	3-7/16"	4-3/4"
63523	23/64"	3-1/2"	4-7/8"
63524	3/8"	3-5/8"	5"
63525	25/64"	3-3/4"	5-1/8"
63526	13/32"	3-7/8"	5-1/4"
63527	27/64"	3-15/16"	5-3/8"
63528	7/16"	4-1/16"	5-1/2"
63529	29/64"	4-3/16"	5-5/8"
63530	15/32"	4-5/16"	5-3/4"
63531	31/64"	4-3/8"	5-7/8"
63532	1/2"	4-1/2"	6"

Cobalt High Speed Steel Fractional Straight Shank Jobber Length Drill Bits



- Constructed of M-35 5 percent cobalt high speed steel for super abrasive resistance in tough metals.
- Heavy-duty spiral flute design produces faster chip ejection.
- Shorter cutting lips reduce torque for drilling in high tensile strength materials.
- 135-Degree split point reduces feed pressure for easier penetration without work hardening.

Item No.	Size	Twist Length	Overall Length
63104	1/16"	7/8"	1-7/8"
63105	5/64"	11/16"	1-11/16"
63106	3/32"	3/4"	1-3/4"
63107	7/64"	13/16"	1-13/16"
63108	1/8"	7/8"	1-7/8"
63109	9/64"	15/16"	1-15/16"
63110	5/32"	1"	2-1/16"
63111	11/64"	1-1/16"	1-1/8"
63112	3/16"	1-1/8"	2-3/16"
63113	13/64"	1-3/16"	2-1/4"
63114	7/32"	1-1/4"	2-3/8"
63115	15/64"	1-5/16"	2-7/16"
63116	1/4"	1-3/8"	2-1/2"
63117	17/64"	1-7/16"	2-5/8"
63118	9/32"	1-1/2"	2-11/16"
63119	19/64"	1-9/16"	2-3/4"
63120	5/16"	1-5/8"	2-13/16"
63121	21/64"	1-11/16"	2-13/16"
63122	11/32"	1-11/16"	3"
63123	23/64"	1-3/4"	3-1/16"
63124	3/8"	1-13/16"	3-1/8"
63125	25/64"	1-7/8"	3-1/4"
63126	13/32"	1-15/16"	3-5/16"
63127	27/64"	2"	3-3/8"
63128	7/16"	2-1/16"	3-7/16"
63129	29/64"	2-1/8"	3-9/16"
63130	15/32"	2-1/8"	3-5/8"
63131	31/64"	2-3/16"	3-11/16"
63132	1/2"	2-1/4"	3-3/4"

29-Piece Black Oxide Metal Index Drill Bit Set – #3018004

- Oxide treatment resists corrosion, helps prevent bit from rusting.
- 135° Split point tip starts on contact, cuts with less force.
- Reduced shank above 3/8" allows the use of larger drill bits in a 3/8" chuck.
- Rubber overmolded case protects kit if dropped.
- Tap & Drill selection chart for convenient reference.
- Automatic indexing for easy bit access and identification.
- Removable cartridges: easy to carry bits from case to worksite.
- Sizes include 1/16" to 1/2" in 1/64" increments.



Bits

Bits - Hammer Drill Bits



SDS-Plus



- Patented carbide tip design cuts fast and is self-centering for simple, controlled starts.
- Short drilling head forces debris into flute for faster penetration speed and extended bit life, and reduces breakout when drilling through-holes.
- Unique flute design clears debris quickly, reducing clogging, minimizing vibration, and increasing overall drilling speed and bit life.
- SDS® Plus shank is compatible with SDS Plus and TEC style drills.*

Item No.	Diameter	Twist Lgth	Overall Lgth
322001	5/32"	2"	4"
322002	5/32"	4"	6"
322002B25	5/32"	4"	6"
322003	3/16"	2"	4"
322003B25	3/16"	2"	4"
322004	3/16"	4"	6"
322004B25	3/16"	4"	6"
322005	3/16"	6"	8"
322005B25	3/16"	6"	8"
322006	3/16"	8"	10"
322006B25	3/16"	8"	10"
322007	3/16"	10"	12"
322007B25	3/16"	10"	12"
322013	7/32"	4"	6"
322013B25	7/32"	4"	6"
322015	7/32"	10"	12"
322015B25	7/32"	10"	12"
322016	1/4"	2"	4"
322016B25	1/4"	2"	4"
322017	1/4"	4"	6"
322017B25	1/4"	4"	6"
322018	1/4"	6"	8"
322018B25	1/4"	6"	8"
322019	1/4"	8"	10"
322020	1/4"	10"	12"
322021	1/4"	12"	14"
322022	5/16"	4"	6"
322022B25	5/16"	4"	6"

Item No.	Diameter	Twist Lgth	Overall Lgth
322023	5/16"	10"	12"
322024	3/8"	4"	6"
322024B25	3/8"	4"	6"
322025	3/8"	8"	10"
322026	3/8"	10"	12"
322026B25	3/8"	10"	12"
322027	3/8"	16"	18"
322028	3/8"	22"	24"
322029	7/16"	4"	6"
322030	7/16"	10"	12"
322031	1/2"	4"	6"
322031B25	1/2"	4"	6"
322032	1/2"	8"	10"
322033	1/2"	10"	12"
322033B25	1/2"	10"	12"
322034	1/2"	16"	18"
322035	1/2"	22"	24"
322036	9/16"	4"	6"
322037	9/16"	10"	12"
322038	9/16"	16"	18"
322041	5/8"	4"	6"
322042	5/8"	6"	8"
322042B25	5/8"	6"	8"
322043	5/8"	10"	12"
322044	5/8"	16"	18"
322045	5/8"	22"	24"
322046	11/16"	6"	8"
322047	3/4"	6"	8"
322048	3/4"	10"	12"
322049	3/4"	16"	18"
322050	3/4"	22"	24"
322051	7/8"	6"	8"
322052	7/8"	10"	12"
322053	7/8"	16"	18"
322054	1"	8"	10"
322055	1"	16"	18"

SDS-Max Multi-Cutter



- Fits all SDS-Max rotary hammers, Hilti TE F/G and Y rotary hammers.
- Patented flute geometry removes dust from the hole quicker for fast drilling and long life.
- Shot-peened, double-tempered finish reduces breakage.
- Copper braze material gives high heat resistance for reduced tip loss.
- All tips made to ANSI specifications.
- Chrome vanadium shaft through-hardened to 50-53HrC.

Item No.	Diameter	Twist Lgth	Overall Lgth
323005	5/8"	8"	13"
323006	5/8"	16"	21"
323007	5/8"	31"	36"
323008	11/16"	16"	21"
323009	3/4"	8"	13"
323010	3/4"	16"	21"
323011	3/4"	31"	36"

Item No.	Diameter	Twist Lgth	Overall Lgth
323012	13/16"	16"	21"
323014	7/8"	8"	13"
323015	7/8"	16"	21"
323016	1"	8"	13"
323017	1"	16"	21"
323018	1"	31"	36"
323020	1-1/8"	10"	15"
323022	1-1/8"	18"	23"
323023	1-1/4"	10"	15"
323024	1-1/4"	18"	23"
323025	1-1/4"	31"	36"
323028	1-3/8"	18"	23"
323031	1-1/2"	18"	23"
323033	1-3/4"	18"	23"
323034	2"	18"	23"

* SDS® Plus is a registered trademark of Robert Bosch GmbH.



Bits - Hammer Drill Bits

Spline Multi-Cutter



- Fits all spline rotary hammers.
- Patented flute geometry removes dust from the hole quicker for fast drilling and long life.
- Shot-peened, double-tempered finish reduces breakage.
- Copper braze material gives high heat resistance for reduced tip loss.
- All tips made to ANSI specifications.
- Chrome vanadium shaft through-hardened to 50-53HRC.

Item No.	Diameter	Twist Lgth	Overall Lgth
BM324050	5/8"	6"	11"
BM324051	5/8"	11"	16"
BM324052	5/8"	18"	23"
BM324053	5/8"	22"	27"
BM324054	5/8"	31"	36"
BM324055	11/16"	11"	16"
BM324056	3/4"	11"	16"
BM324057	3/4"	8"	13"
BM324058	3/4"	18"	23"
BM324059	3/4"	22"	27"
BM324060	3/4"	31"	36"
BM324063	7/8"	11"	16"
BM324064	7/8"	18"	23"
BM324065	1"	11"	16"
BM324066	1"	18"	23"
BM324067	1"	31"	36"
BM324068	1"	22"	27"
BM324070	1-1/8"	11"	16"
BM324071	1-1/8"	18"	23"
BM324072	1-1/4"	11"	16"
BM324073	1-1/4"	18"	23"
BM324074	1-1/4"	31"	36"
BM324076	1-3/8"	18"	23"
BM324078	1-1/2"	18"	23"
BM324080	1-3/4"	18"	23"
BM324081	2"	18"	23"

SDS-Max® Shank Demolition Bits



Item No.	Point Type	Dimensions
332000	Moil Point	12"
332001	Moil Point	18"
332002	Moil Point	24"
332003	Flat Chisel	1" x 12"
332004	Flat Chisel	1" x 18"
332005	Flat Chisel	1" x 24"
332006	Scaling Chisel	1-1/2" x 12"
332007	Scaling Chisel	1-1/2" x 18"
332008	Scaling Chisel	2" x 12"
332009	Scaling Chisel	2" x 18"
333010	Wide Scaling Chisel	3" x 12"
333011	Angled Scraping Chisel	2" x 12"
332012	Mortar-Seam Tool	1-1/8" x 12"
332013	Slotting Chisel	1-3/8" x 12"
332014	Clay Spade	4" x 17"
332015	Asphalt Cutter	4-3/8" x 16"
332019	Ground Rod Driver	5/8" - 3/4" x 10"

**1-Piece Hammer Bits
SDS-Max Shank**



- Fit all SDS-Max and Hilti TE F/G and Y rotary hammers.
- Delivers power to the tips more efficiently than 2-piece designs.
- Reduces breakage and other problems associated with 2-piece designs.
- Maximum drilling depth is 2-5/8".

Item No.	Diameter	Overall Lgth
325014	1-1/2"	12"
325015	1-1/2"	22"
325016	2"	12"
325017	2"	22"
325018	2-1/2"	12"
325019	2-1/2"	22"
325020	3-1/8"	12"
325021	3-1/8"	22"
325022	3-1/2"	12"
325023	3-1/2"	22"
325024	4"	12"
325025	4"	22"
325026	5"	22"
325027	6"	22"

Adapters

Item No.	Description
327001	Adapter, SDS-Max® to SDS-Plus
327002	Adapter, Spline to SDS-Plus

Moil Point



Flat Chisel



Scaling Chisel



Wide Scaling Chisel



Bush Tool - 1-Piece



Ground Rod Driver



Clay Spade



Asphalt Cutter



EXPERIENCE THE DIFFERENCE

Bits - Spade, Auger & Step Drill Bits

Standard Length Spade Bits



- Patented Blue-Groove™ point and cutting edge for faster chip removal and overall drilling speed.
- Double cutting spurs scribe the outside of the hole for reduced breakout and cleaner holes.
- 40% Thicker cutting edge and enlarged shank for increased strength and longer drilling life.

Item No.	Diameter	Overall Length	Shank Size
88804	1/4"	6"	1/4" Quick-Change
88805	5/16"	6"	1/4" Quick-Change
88806	3/8"	6"	1/4" Quick-Change
88807	7/16"	6"	1/4" Quick-Change
88808	1/2"	6"	1/4" Quick-Change
88809	9/16"	6"	1/4" Quick-Change
88810	5/8"	6"	1/4" Quick-Change
88811	11/16"	6"	1/4" Quick-Change
88812	3/4"	6"	1/4" Quick-Change
88813	13/16"	6"	1/4" Quick-Change
88814	7/8"	6"	1/4" Quick-Change
88815	15/16"	6"	1/4" Quick-Change
88816	1"	6"	1/4" Quick-Change
88818	1-1/8"	6"	1/4" Quick-Change
88820	1-1/4"	6"	1/4" Quick-Change
88822	1-3/8"	6"	1/4" Quick-Change
88824	1-1/2"	6"	1/4" Quick-Change

Power Drill Long Ship Auger Bits



- Durable hardened cutting edge for long life in tough materials, including nail-embedded wood.
- Fully-forged bit for maximum durability.
- Wide flutes for maximum chip removal and less binding.

Item No.	Diameter	Overall Length	Shank Size
47306	3/8"	17"	5/16"
47307	7/16"	17"	5/16"
47308	1/2"	17"	5/16"
47309	9/16"	17"	7/16"
47310	5/8"	17"	7/16"
47311	11/16"	17"	7/16"
47312	3/4"	17"	7/16"
47313	13/16"	17"	7/16"
47314	7/8"	17"	7/16"
47315	15/16"	17"	7/16"
47316	1"	17"	7/16"
47317	1-1/16"	17"	7/16"
47318	1-1/8"	17"	7/16"
47319	1-3/16"	17"	7/16"
47320	1-1/4"	17"	7/16"
47321	1-5/16"	17"	7/16"
47322	1-3/8"	17"	7/16"
47324	1-1/2"	17"	7/16"
47326	1-5/8"	17"	7/16"
47328	1-3/4"	17"	7/16"
47332	2"	17"	7/16"

High Speed Steel Fractional Hole Enlarging



10221

- Single-flute cutting edge for greater control through steps.
- 3-Flatted shank prevents slipping in drill chuck.
- Patented single-flute cutting edge gives the user a true round hole every time.
- Ideal for drilling holes into thin materials such as stainless steel, copper, brass, aluminum, plastic and laminates.
- Pilot hole required.

Item No.	Desc.	Hole Sizes	Number Of Holes	Maximum Material Thickness
10220	#20	9/16" - 1"	8 steps	1/8"
10221	#21	13/16" - 1-3/8"	10 steps	1/8"

High Speed Steel Fractional Self-Starting



10239

- SpeedPoint® tip for fast starts. (included on all self-starting sizes except for 10231)
- Geometry of single-flute cutting edge drills true, round holes and provides maximum step control.
- Permanent laser-etched sizes inside flute for easy hole size identification.

Item No.	Desc.	Hole Sizes	Number Of Holes	Maximum Material Thickness
10231	#1	1/8" - 1/2"	13 steps	1/8"
10232	#2	3/16" - 1/2"	6 steps	3/8"
10233	#3	1/4" - 3/4"	9 steps	1/8"
10234	#4	3/16" - 7/8"	12 steps	1/8"
10235	#5	1/4" - 1-3/8"	10 steps	1/8"
10239	#9	7/8" and 1-1/8"	2 steps	1/8"
10310	#10	1/2"	N/A	N/A
10311	#11	7/8"	N/A	N/A
10312	#12	3/8"	N/A	N/A
10313	#13	1-1/8"	N/A	N/A
10314	#14	1-7/32"	N/A	N/A

Unibit Step Drill Set - #10502



- Single-flute cutting edge for greater control through steps.
- 3-Flatted shank prevents slipping in drill chuck.
- Non-skid self-starting tip eliminates skidding and the need for center punching.
- 3-Piece set - 10231, 10232 & 10233.



Bits - Hole Saws & Arbors

Bi-Metal Hole Saws

- Patented WeldTec™ 4.5/5.5 variable tooth design provides longer life and improves cutting performance.
- Variable depth gullets reduce friction and improve chip clearance efficiency.

Item No.	Dia.	Pipe Entrance	Pipe Tap	Recommended RPM (In Steel)
373090BX	9/16"	-	-	580
373508BX	5/8"	-	-	550
373011BX	11/16"	-	-	500
373034BX	3/4"	3/8"	1/2"	460
373013BX	13/16"	-	-	425
373078BX	7/8"	1/2"	3/4"	390
373015BX	15/16"	-	-	370
373100BX	1"	-	-	350
373110BX	1-1/16"	-	-	325
373118BX	1-1/8"	3/4"	1"	300
373130BX	1-3/16"	-	-	285
373114BX	1-1/4"	-	-	275
373150BX	1-5/16"	-	-	260
373138BX	1-3/8"	1"	-	250
373170BX	1-7/16"	-	-	240
373112BX	1-1/2"	-	1-1/4"	230
373190BX	1-9/16"	-	-	220
373158BX	1-5/8"	-	-	210
373111BX	1-11/16"	-	-	205
373134BX	1-3/4"	1-1/4"	1-1/2"	195
373113BX	1-13/16"	-	-	190
373178BX	1-7/8"	-	-	180
373200BX	2"	1-1/2"	-	170
373210BX	2-1/16"	-	-	165
373218BX	2-1/8"	-	-	160
373214BX	2-1/4"	-	2"	150
373250BX	2-5/16"	-	-	140
373238BX	2-3/8"	-	-	140
373212BX	2-1/2"	2"	-	135
373290BX	2-9/16"	-	-	130
373258BX	2-5/8"	-	2-1/2"	130
373234BX	2-3/4"	-	-	125
373278BX	2-7/8"	-	-	120
373300BX	3"	2-1/2"	-	115
373318BX	3-1/8"	-	-	110
373314BX	3-1/4"	-	3"	105
373338BX	3-3/8"	-	-	100
373312BX	3-1/2"	-	-	95
373358BX	3-5/8"	3"	-	95
373334BX	3-3/4"	-	3-1/2"	90
373378BX	3-7/8"	-	-	85
373400BX	4"	-	-	85
373418BX	4-1/8"	3-1/2"	-	80
373414BX	4-1/4"	-	4"	80
373348BX	4-3/8"	-	-	75
373412BX	4-1/2"	-	4-1/2"	75
373434BX	4-3/4"	-	-	70
373500BX	5"	-	-	65
373512BX	5-1/2"	-	-	60
373600BX	6"	-	-	55



Hole Saw Arbors

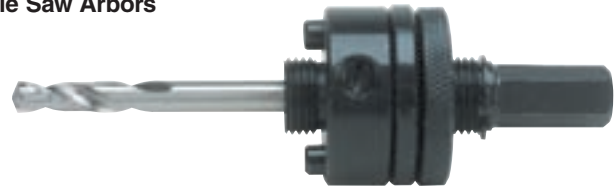

- Tough, durable construction.
- For 3/8" and 1/2" drill chucks.
- Removable pilot drill for easy replacement.

Item No.	Shank Size	Shank Type	Fits Sizes	Pin Driven
373002	1/2"	Standard Hex	9/16" - 1-3/16"	No
373003	3/8"	Standard Hex	1-1/4" - 6"	Yes
373004	1/2"	Standard Hex	1-1/4" - 6"	Yes
373005	1/4"	Quick Change Hex	9/16" - 1-3/16"	No
373000	-	1/4" Replacement Pilot Drill		

Bi-Metal Hole Saw Sets



- Contains the most commonly used sizes for electricians.
- Heavy-duty Bi-Metal construction extends life and increases durability.
- Super hard steel RC 65-66 for increased life.
- Bi-metal construction for toughness and long life.
- Clearly printed hole saw sizes for quick retrieval and added productivity.

Item No.	Description	Contents
3073003	Electrician's 9-piece Bi-Metal Hole Saw Kit	7/8", 1-1/8", 1-3/8", 1-3/4", 2", 2-1/2", 1/2" Hex, 3/8" Hex, Pilot Drill

Bits - Fastener Drives

Fractional Nutsetters



- For use with sheet metal screws and other hexagonal head fasteners.
- Magnetic Nutsetters use rare earth magnets, holds nuts securely.

Item No.	Size	Description	Overall Lgth
94209	3/16"	Nutsetter	1-7/8"
94211	1/4"	Nutsetter	1-7/8"
94212	1/4"	Magnetic Nutsetter	1-7/8"
94215	1/4"	Nutsetter - Tapered	1-7/8"
94216	1/4"	Magnetic Nutsetter - Tapered	1-7/8"
94231	5/16"	Nutsetter	1-7/8"
94232	5/16"	Magnetic Nutsetter	1-7/8"
94251	3/8"	Nutsetter	1-7/8"
94252	3/8"	Magnetic Nutsetter	1-7/8"
94271	7/16"	Nutsetter	1-7/8"
94272	7/16"	Magnetic Nutsetter	1-7/8"
94291	1/2"	Nutsetter	1-7/8"
94311	1/4"	Nutsetter	2-9/16"
94312	1/4"	Magnetic Nutsetter	2-9/16"
94316	1/4"	Magnetic Nutsetter	2-9/16"
94331	5/16"	Nutsetter	2-9/16"
94332	5/16"	Magnetic Nutsetter	2-9/16"
94335	5/16"	Nutsetter	2-9/16"
94336	5/16"	Magnetic Nutsetter	2-9/16"
94351	3/8"	Nutsetter	2-9/16"
94352	3/8"	Magnetic Nutsetter	2-9/16"
94356	3/8"	Magnetic Nutsetter	2-9/16"
94371	7/16"	Nutsetter	2-9/16"
94372	7/16"	Magnetic Nutsetter	2-9/16"
94414	1/4"	Magnetic Nutsetter	4"
94416	1/4"	Magnetic Nutsetter	6"
94434	5/16"	Magnetic Nutsetter	4"
94436	5/16"	Magnetic Nutsetter	6"

Phillips® Head Insert Bits



- Made of high grade S2 Steel.

Item No.	Size	Description	Overall Lgth
92001	#0	Phillips Insert Bit	1"
92005	#1	Phillips Insert Bit	1"
92007	#1	Phillips Drywall Insert Bit	1"
92011	#2	Phillips Insert Bit	1"
92019	#3	Phillips Insert Bit	1"
92025	#1	Phillips Insert Bit	1-1/2"
92027	#2	Phillips Insert Bit	1-1/2"
92035	#3	Phillips Insert Bit	1-1/2"
92039	#2	Phillips Insert Bit	2"
92045	#2	Phillips Insert Bit	2-1/2"
92047	#2	Phillips Drywall Insert Bit	1"
92053	#2	Phillips Drywall Insert Bit	2"
92073	#1	Phillips Insert Bit	1-1/4"
92075	#2	Phillips Insert Bit	1-1/4"
92077	#3	Phillips Insert Bit	1-1/4"
92079	#4	Phillips Insert Bit	1-1/4"

Slotted Insert Bits



- Made of high grade S2 Steel.

Item No.	Point Size	Description	Shank Diameter	Overall Length
92105	3-4	Slotted Insert Bit	1/4"	1"
92107	4-5	Slotted Insert Bit	1/4"	1"
92111	6-8	Slotted Insert Bit	1/4"	1"
92113	8-10	Slotted Insert Bit	1/4"	1"
92115	10-12	Slotted Insert Bit	1/4"	1"
92117	12-14	Slotted Insert Bit	1/4"	1"
92119	14-16	Slotted Insert Bit	1/4"	1"
92135	4-5	Slotted Insert Bit	1/4"	1-1/2"
92139	6-8	Slotted Insert Bit	1/4"	1-1/2"
92141	8-10	Slotted Insert Bit	1/4"	1-1/2"
92143	10-12	Slotted Insert Bit	1/4"	1-1/2"
92145	12-14	Slotted Insert Bit	1/4"	1-1/2"
92147	14-16	Slotted Insert Bit	1/4"	1-1/2"
92163	3-4	Slotted Insert Bit	5/16"	1-1/2"
92165	4-5	Slotted Insert Bit	5/16"	1-1/2"
92169	6-8	Slotted Insert Bit	5/16"	1-1/2"
92171	8-10	Slotted Insert Bit	5/16"	1-1/2"
92173	10-12	Slotted Insert Bit	5/16"	1-1/2"
92175	12-14	Slotted Insert Bit	5/16"	1-1/2"
92177	14-16	Slotted Insert Bit	5/16"	1-1/2"

1/4" Hex Shank Bit Holders



- Designed for insert bits only.
- C-ring design has internal clip that fits into the retaining ring notch of the insert bit to hold bit securely in place.

Item No.	Description	Point Size	Overall Length
93718	1/4" Hex Shank Holder	Standard with C-Ring	3"

7/16" Hex Shank Square Drive Socket Adapter



- Pin lock design for production applications.

Item No.	Description	Lock Type	Overall Length
93748	Socket Adapter	Pin	5"

Abatix' online ordering system is simple to use. Once you are registered and have a customer code, you can create orders, customize shopping lists, and view ordering history, track shipments, view and print invoices and pay bills online. Head over to www.abatix.com and start shopping today.

Bits - Core Bits

Supreme Series Core Bits Wet Cut

Our Supreme Series Wet Cut Concrete Core Bits employ a quick-starting V-Shaped segment with a castellated/turbo design for additional aggression and faster cutting. Laser-welded segments add strength and durability while the fully threaded and machined cap eliminates lateral run out (bit wobble), and allows use of our unique Extend-A-Tube extension system.

BEST

- Item# **LMD20010** 1" x 15" x 5/8" - 11, Threaded
- Item# **LMD20020** 2" x 15" x 1-1/4" - 7, Threaded
- Item# **LMD20030** 3" x 15" x 1-1/4" - 7, Threaded
- Item# **LMD20040** 4" x 15" x 1-1/4" - 7, Threaded
- Item# **LMD20050** 5" x 15" x 1-1/4" - 7, Threaded
- Item# **LMD20015** 1-1/2" x 15" x 5/8" - 11, Threaded
- Item# **LMD20025** 2-1/2" x 15" x 1-1/4" - 7, Threaded
- Item# **LMD20035** 3-1/2" x 15" x 1-1/4" - 7, Threaded
- Item# **LMD20045** 4-1/2" x 15" x 1-1/4" - 7, Threaded
- Item# **LMD20060** 6" x 15" x 1-1/4" - 7, Threaded



Core Bits



Pearl Abrasive Co. offers a wide variety of core bits for use on a variety of applications. Pearl has special wet core bits for concrete, marble, granite, and stone, as well as special dry core bits for coring holes in a variety of materials. Whether the need is cutting a 1-3/8" hole in granite or cutting a 6" hole in concrete, Pearl has the core bit for you.

CORE BITS FOR CONCRETE

Premium Wet

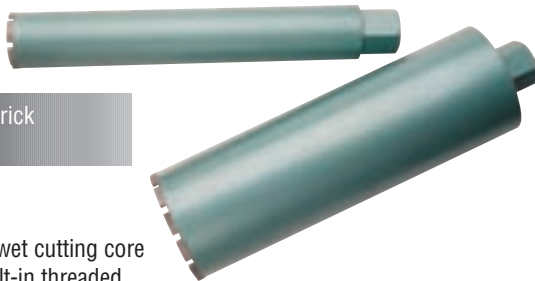

Concrete, Brick and Stone.

Heavy-duty wet cutting core bits with built-in threaded adapters. Quality construction and performance. 100% GE diamonds – no inferior substitutes. Precision machined barrel ensures each bit runs true with less vibration. Applications include core sampling, construction, plumbing and electrical installations. Use with core drilling machines when cutting through concrete, brick and stone.



PT. NUMBER	SPECS
HB200L14	2 x 14
HB212L14	2-1/2 x 14
HB300L14	3 x 14
HB312L14	3-1/2 x 14
HB400L14	4 x 14
HB414L14	4-1/4 x 14
HB600L14	6 x 14

Blades - Saw Blades

High Speed Contractor Series Blades

Our High Speed Blade series delivers excellent speed of cut and longevity at an affordable price. Designed for wet or dry cutting of cured concrete and masonry applications, High-Speed Contractor Blades are intended for use on highspeed hand-held saws, masonry saws as well as low horsepower walk-behind saws. Cutting applications include: Cured Concrete, Block, Paver and Brick. Also available with straight 20mm arbors.

BEST

Item# **LMDEDH141251** 14" x .125 x 1"

BETTER

Item# **LMDSG14CHP1** 14" x .125 x 1"

GOOD

Item# **LMDSG14SPP-PLUS** 14" x .125 x 1"



High Speed Green Concrete/Asphalt Blades

Dry Cutting Green Concrete and Asphalt blades are specially designed for "New Pour" concrete (fresh pour to 48 hours) and highly abrasive asphalt cutting applications. Proper bonding, core protection, pre & post tensioning and state of the art laser welding maximize the speed of cut and longevity. Designed for wet or dry cutting in Asphalt or Green Concrete on Hand Held High-Speed Saws, Air Saws, and Low Horsepower Walk-Behind Saws.

GOOD

Item# **LMHA14SPL1251** 14" x .125 x 1"



Small Diameter Segmented Blades Wet or Dry Cut

Small Diameter Segmented blades are designed for wet or dry cutting of general purpose cured concrete and masonry applications and are to be used on small saws and angle grinders. These blades are traditional in style and are very aggressive due to their gullet and keyhole design.

GOOD

Item# **LMDSG4.5SPL** 4.5" x .090 x 7/8"

Item# **LMDSG7SPL** 4.5" x .100 x 7/8"



Demolition Blades Wet or Dry

This blade is designed to cut through various roofing materials including stone, gravel, tar, fiberglass, metal sheeting, and resin fiber. The 911 is ideal in emergency fire and rescue operations, as well as demolition projects. The 911 is manufactured with jagged carbide segments that chop and rip through materials quickly and efficiently.

BEST

Item# **LMDDMO141** 14" x .250 x 1"



Continued on next page

EXPERIENCE THE DIFFERENCE

Blades - Saw Blades

(Continued)

Multi-Application Blades

The STS-5 is a hybrid of traditional segmented and turbo blades, offering the best of both worlds. This blade is the only true multi-application diamond blade. Cutting applications include: Cured Concrete, Green Concrete, Asphalt, Block, Stone, Granite, Piling, Overlay, Brick & Block combination and more. Suitable for use on Hand Saws, Hand-Held High-Speed Saws, Low Horsepower Walk-Behind, and Masonry Saws. Also available with 20mm arbors.

BEST

Item# **LMDSTS5141251** 14" x .125 x 1"

BETTER

Item# **LMDSTS4141251** 14" x .125 x 1"



Small Diameter Turbo Blades

One of the most popular diamond blades, due to its reputation for clean edging and precise cuts, is the Continuous Rim Turbo blade. These blades can take abuse – while giving a more precise finish than a traditional segmented blade. The castellated design provides an aggressive cut. This blade is a favorite in the marble, granite, and stone industries. Continuous Rim Turbo blades are perfect for use on small power tools such as angle grinders and circular saws. Additional sizes available.



GOOD

Item# **LMDTB4.5SPL** 4.5" x .090 x 7/8"

Item# **LMDTB7SPL** 4.5" x .100 x 7/8"

Blades - Diamond Concrete Cutting

SEGMENTED Diamond Blades

CONCRETE BLADES

PRO-V™ SERIES



PT. NUMBER	SPECS	MAX RPM
PV004S	4 x .080 x 20mm, 5/8	13,700
PV045S	4-1/2 x .080 x 7/8, 5/8	13,300
PV005S	5 x .080 x 7/8, 5/8	12,200
PV007S	7 x .090 x 7/8, ◇, 5/8	8,500



PRO-V™ SERIES



PT. NUMBER	SPECS	MAX RPM
PV1212XL	12 x .125 x 1	6,300
PV1212XL2	12 x .125 x 20mm	6,300
PV1412XL	14 x .125 x 1	5,400



TURBO RIM Diamond Blades

Pearl's turbo rim diamond blades are designed for cutting a wide variety of material. They combine the speed of a segmented blade with a clean cut of a continuous rim blade. Pearl's turbo rim blades are developed with high quality control standards you have come to expect from Pearl. These turbo rim blades are excellent for use on concrete, brick, block, marble, natural stone and much more.

PRO-V™ SERIES

Turbo Blade

Block, Brick, Concrete, Marble, Natural Stone, Refractory Material, Soft Stone, Sandstone.



Large 10mm diamond rim height for longer life. Strong (.080") steel core for durability. Turbo rim for fast, minimal chipping.



PT. NUMBER	SPECS	MAX RPM
PV004T	4" x .080 x 20mm, 5/8	13,700
PV045T	4-1/2" x .080 x 7/8, 5/8	13,300
PV005T	5" x .080 x 7/8, 5/8	12,200
PV007T	7" x .090 x 7/8, ◇, 5/8	8,500

Don't see what you are looking for? Ask your Abatix Sales Representative. Abatix carries tens of thousands of products. **We will make sure you get what you need, when you need it, where you need it.**

Blades - Circular Saw Blades

Marathon® Portable Corded Circular Saw Blades



- New and improved design.
- The Fastest Framing Blade Ever!™
- Construction-grade carbide teeth for longer life.
- Every other tooth is thinner for faster cuts.
- New heat vent/expansion slot design reduces vibration for longer life and straighter cuts.
- Reinforced shoulder for added durability.
- Fully hardened plate runs truer, longer.



IRWIN Classic Series Circular Saw Blades



- The best value for an economy blade.
- Corrosion-resistant coating helps prevent rusting.
- Precision-ground teeth for smooth, accurate cuts.
- Slots for Straighter Cuts.



Item No.	Diameter	Teeth	Arbor	Kerf	Hook Angle	Grind
24030	7-1/4"	24	5/8" Diamond	.071"	20°	ATB
25130	7-1/4"	24	5/8"	2.7mm	18°	ATB

METAL DEVIL® Metal Cutting Circular Saw Blades



Diameter Inches	Diameter mm	Teeth Per Inch	Application	Arbor	Part No.	Model No.
5-3/8	137	30	Steel	5/8	100717	CSM5383058SC
5-3/8	137	50	Thin Steel	20mm-10mm/ 5/8	100021	CSM53850TSC
6-1/4	159	60	Aluminum	5/8	100052	CSM62560AC
6-1/2	165	48	Thin Steel	20mm	100649	CSM6504820TSC
6-1/2	165	48	Thin Steel	5/8	100076	CSM65048TSC
6-1/2	165	60	Aluminum	5/8	100083	CSM65060AC
7	178	48	Stainless	20mm	100144	CSM748SSC
7	178	68	Thin Steel	20mm	100168	CSM768TSC
7-1/4	184	50	Steel	5/8 KO	100182	CSM72550SC
7-1/4	184	60	Aluminum	20mm	100663	CSM7256020AC
7-1/4	184	68	Thin Steel	5/8 KO	100397	CSM72568TSC
7-1/2	191	68	Thin Steel	20mm	100236	CSM75068TSC
8	203	40	Steel	5/8	100243	CSM840SC
8	203	68	Thin Steel	5/8	100274	CSM868TSC
8-1/4	210	50	Steel	5/8 KO	100281	CSM82550SC
9	229	48	Steel	1	100304	CSM948SC
9	229	60	Stainless	1	100403	CSM960SSC
9	229	68	Thin Steel	1	100311	CSM968TSC
10	254	52	Thin Steel	5/8 KO	100410	CSM1052TSC
12	305	80	Thin Steel	1	100342	CSM1280TSC
14	356	81	Studs	1	100670	CSM1481STC
14	356	90	Stainless	1	100694	CSM1490SSC
14	356	90	Thin Steel	1	100380	CSM1490TSC

5-3/8" blades include special bushings allowing them to fit 20mm, 10mm and 5/8" arbor holes. 5/8 KO fits both diamond and circular arbors.

Blades

EXPERIENCE THE DIFFERENCE

Blades - SawZall Blades

12 PC. SAWZALL® BLADE SET

- Includes New wood blades featuring NAIL GUARD™ and FANG TIP™.
- NAIL GUARD™ combines an aggressive 5 TPI pattern for faster cutting, with a unique design that protects against tooth fractures.
- The FANG TIP™ design bites into wood on first contact for faster plunging.
- Thicker blade stock for maximum durability.
- 1" tall blade profile for straighter cuts.
- Double relief angle reduces tooth stress for long life.
- Matrix II bi-metal teeth for greater durability.
- Jobsite durable storage case adjusts to hold up to 9" blades.



Includes

- Four (4) 6" 18 TPI The Torch® blades
- Two (2) 6" 8 TPI The Wrecker™ blades
- Two (2) 6" 5/8 TPI The Ax™ blades
- Two (2) 9" 5/8 TPI The Ax™ blades
- Two (2) 9" 14 TPI The Torch® blades
- One (1) storage container

Item# **MIL49-22-1129**

9 PC. SAWZALL® BLADE SET

- Includes New wood blades featuring NAIL GUARD™ and FANG TIP™.
- NAIL GUARD™ combines an aggressive 5 TPI pattern for faster cutting, with a unique design that protects against tooth fractures.
- The FANG TIP™ design bites into wood on first contact for faster plunging.
- Precision forming process creates sharper teeth for fast cutting.
- Double relief angle reduces tooth stress for long life.
- Matrix II bi-metal teeth for greater durability.
- Jobsite durable storage case adjusts to hold up to 9" blades.



Includes

- Three (3) 6" 24 TPI blades
- Three (3) 6" 14 TPI blades
- Two (2) 6" 6 TPI blades
- One (1) 9" 6 TPI blade
- One (1) Storage Container

Item# **MIL49-22-1145**

ICE HARDENED™ 14 PC METAL CUTTING SAWZALL® BLADE SET

- Ice Hardened™ for up to 50% longer life.
- A unique combination of relief angles forms a radius on the back of the tooth that reduces stress build-up during cutting and substantially extends blade life.
- Precision forming process creates sharper teeth for fast cutting.
- Matrix II bi-metal teeth for greater durability.



Includes

- Four (4) 6" 14 TPI blades
- Four (4) 6" 18 TPI blades
- Two (2) 9" 10 TPI The Torch® blades
- Two (2) 9" 14 TPI The Torch® blades
- Two (2) 9" 18 TPI The Torch® blades
- One (1) Storage Pouch

Item# **MIL49-22-1131**

Blades - Band Saw Blades

18 TPI COMPACT AND SUB-COMPACT PORTABLE BAND SAW BLADES (3) PACKS

- Matrix II high speed steel teeth deliver maximum durability.
- Alloy backing steel provides extended blade life.
- Precision formed teeth create fast, clean cuts.
- For cutting common materials 5/32" - 3/16" thick and very hard materials 3/16" - 5/16" thick.

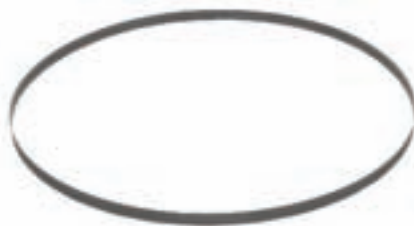

Includes

- (3) Portable Band Saw Blades

Item# **MIL48-39-0572** (Sub-Compact) (27" x 1/2" x .020")

Item# **MIL48-39-0529** (Compact) (35-3/8" x 1/2" x .020")

BI-METAL BAND SAW BLADES

44-7/8" x 1/2" x .020



High speed cutting of aluminum, angle iron, bronze, brass, copper, galvanized pipe, mild steel. Tougher steels including stainless, chrome, tungsten steel plus other problem material at slow speed.

Catalog Number	Qty. Per Pkg.	Diameter Or Wall Thickness	Teeth Per Inch
48-39-0514	2	3/16"-5/16"	14
48-39-0522	100	5/32"-3/16"	18
48-39-0532	100	Up to 5/32"	24



Cases



1400 Case

- Interior dimensions: 11.81" x 8.87" x 5.18" (30 x 22.5 x 13.2cm).
- Watertight, crushproof and dust proof.
- Easy open Double Throw latches.
- Open cell core with solid wall design – strong, lightweight.
- O-ring seal.
- Automatic Pressure Equalization Valve.
- Stainless steel padlock protectors.
- Comfortable rubber over-molded handle.
- Stainless steel hardware.
- Pick N Pluck™ with convoluted lid foam.
- Personalized nameplate service available.
- Lifetime Guarantee of Excellence.

Item# **PEL1400BLK** (Black)

1490 Case

- Interior dimensions: 17.75" x 11.37" x 4.12" (45.1 x 28.9 x 10.5cm).
- Fits notebook computers up to 17.3"L x 11"W x 3.3"D.
- Double safety locking latches with keys.
- Open cell core with solid wall design – strong, lightweight.
- Automatic Pressure Equalization Valve.
- O-ring seal.
- Comfortable rubber over-molded handle.
- Stainless steel hardware.
- Pick N Pluck™ with convoluted lid foam.
- Personalized nameplate service available.
- Lifetime Guarantee of Excellence.
- Watertight, crushproof and dust proof.

Item# **PEL1490** (Black)

1500 Case

- Interior dimensions: 16.75" x 11.18" x 6.12" (42.5 x 28.4 x 15.5cm).
- Watertight, crushproof and dust proof.
- Easy open Double Throw latches.
- Open cell core with solid wall design – strong, lightweight.
- O-ring seal.
- Automatic Pressure Equalization Valve.
- Comfortable rubber over-molded handle.
- Stainless steel hardware and padlock protectors.
- Pick N Pluck™ with convoluted lid foam.
- Personalized nameplate service available.
- Lifetime Guarantee of Excellence.

Item# **PEL1500BK** (Black)

Item# **PEL1500YL** (Yellow)

1510 Carry On Case

- Interior dimensions: 19.75" x 11" x 7.6" (50.1 x 27.9 x 19.3cm).
- FAA maximum carry on size.
- Retractable extension handle.
- Strong polyurethane wheels with stainless steel bearings.
- Easy open Double Throw latches.
- Padded dividers.
- Open cell core with solid wall design – strong, lightweight.
- O-ring seal.
- Automatic Pressure Equalization Valve.
- Comfortable rubber over-molded top and side handles.
- Stainless steel hardware and padlock protectors.
- Pick N Pluck™ with convoluted lid foam.
- Personalized nameplate service available.
- Lifetime Guarantee of Excellence.
- Watertight, crushproof and dust proof.

Note: This case has internal wheel and/or handle wells that will reduce usable area. Please review for each application.

Item# **PEL1514 BLACK** (Black)

1650 Case

- Interior dimensions: 28.57" x 17.52" x 10.65" (72.5 x 44.5 x 27cm).
- Retractable extension handle.
- 4 Strong polyurethane wheels with stainless steel bearings.
- Easy open Double Throw latches.
- Open cell core with solid wall design – strong, lightweight.
- O-ring seal.
- Automatic Pressure Equalization Valve.
- Fold down handles.
- Stainless steel hardware and padlock protectors.
- 2 level Pick N Pluck™ with convoluted lid foam.
- Personalized nameplate service available.
- Lifetime Guarantee of Excellence.
- Watertight, crushproof and dust proof.

Note: This case has internal wheel and/or handle wells that will reduce usable area. Please review for each application.

Item# **PEL1650BK** (Black)

Abatix' online ordering system is simple to use. Once you are registered and have a customer code, you can create orders, customize shopping lists, and view ordering history, track shipments, view and print invoices and pay bills online. Head over to www.abatix.com and start shopping today.

EXPERIENCE THE DIFFERENCE

Chemicals - Disinfectants & Antimicrobials



SHOCKWAVE – DISINFECTANT, SANITIZER, CLEANER State-of-the-Art Disinfectant, Sanitizer and Cleaner



ShockWave is an EPA-registered disinfectant, sanitizer and cleaner designed specifically for mold remediation contractors. ShockWave is designed to meet all your disinfecting, sanitizing, cleaning, and de-odorizing needs. ShockWave is strong enough to be used as a hospital grade disinfectant, and has been specifically formulated to be used on both porous and non-porous materials. ShockWave is a powerful concentrated quaternary ammonium chloride blend that yields up to 64 gallons of usable product from every gallon of concentrate. ShockWave has over 130

organism kill claims including *Aspergillus niger*, *Penicillium spinulosum*, *E. coli*, *Salmonella*, HIV, Hepatitis-B, Herpes, Poliovirus, and many other pathogenic and environmental microbial organisms.

Specifications
 EPA Registration Number61178-1-73884
 Active IngredientQuaternary Ammonium Chloride
 Color.....Clear Blue
 Odor.....Fresh Linen
 Flash Point.....>200°F
 pH.....11.7
 Shelf Life (Original Sealed Container)36 months min.
 Calculated VOC0 Grams/liter
 Minimum Application Temperature32°F

Item# **FLK8310** (1 Gal.)
 Item# **FLK8310-CA** (1 Gal.) (VOC/CARB Compliant)

IAQ 1000 – HYDROGEN PEROXIDE BASED CLEANER Cleans and Whitens Mold Covered Surfaces



IAQ 1000 is a hydrogen peroxide based biodegradable, chlorine free cleaner. IAQ 1000 is pH-neutral, and contains an agent that will whiten and brighten while cleaning, but does not contain sodium hypochlorite (bleach). IAQ 1000 is suitable for use in water damage restoration situations to remove odor causing mold, mildew, bacteria and other microbial growth on porous, semi-porous and non-porous materials. IAQ 1000 contains no dyes or perfumes, and is not corrosive like many industrial cleaners.

IAQ 1000 is specifically designed for cleaning after water damage, sewer backups and floods. IAQ 1000 is supplied in a powerful, ready-to-use formula that can be applied directly from the container.

Specifications
 Active IngredientHydrogen Peroxide
 Color.....Clear
 Odor.....None
 Flash Point.....Non-Combustible
 pH.....6.5-7.5
 Shelf Life (Original Sealed Container)12 months min.
 Calculated VOC0 Grams/liter

Item# **FLK8315** (5 Gal.)

IAQ 2000 – HARD SURFACE DISINFECTANT Disinfect Hard Non-Porous Surfaces



IAQ 2000 is an EPA registered disinfectant and cleaner designed to kill and control fungal, bacterial and virucidal growth. Fiberlock IAQ 2000 is a concentrated, phosphate free formulation designed to provide effective cleaning, deodorizing and disinfection specifically for schools, retail business and commercial buildings, and other places where housekeeping is of prime importance in controlling the hazard of microbial contamination. When used as directed, Fiberlock IAQ 2000 disinfects

hard, nonporous, inanimate, environmental surfaces, including floors and walls, that are prone to problems caused by microorganisms.

Specifications
 EPA Registration Number1839-95-73884
 Active IngredientQuaternary Ammonium Chloride
 Color.....Clear Blue
 Odor.....Fresh Linen
 Flash Point.....>200°F
 pH.....11.7
 Shelf Life (Original Sealed Container)36 months min.
 Calculated VOC0 Grams/liter
 Minimum Application Temperature32°F
 Item# **FLK8320** (1 Gal.)

IAQ 2500 – READY-TO-USE HARD SURFACE DISINFECTANT Disinfect Hard Non-Porous Surfaces



IAQ 2500 is designed specifically as a general non-acid cleaner and disinfectant for use in homes, schools, office buildings, and retail businesses. It is formulated to disinfect hard, nonporous, inanimate environmental surfaces: floors, walls, glazed porcelain, glazed ceramic tile, plastic surfaces, bathrooms and cabinets. For plastic and painted surfaces, spot test on an inconspicuous area before use. A rinse with potable water is required for surfaces in direct contact with food. EFFICACY TESTS

HAVE DEMONSTRATED THAT FIBERLOCK IAQ 2500 IS AN EFFECTIVE BACTERICIDE, FUNGICIDE, AND VIRUCIDE, IN THE PRESENCE OF ORGANIC SOIL (5% BLOOD SERUM).

Specifications
 EPA Registration Number1839-83-73884
 Active IngredientQuaternary Ammonium Chloride
 Color.....Clear Blue
 Odor.....Fresh Linen
 Flash Point.....>200°F
 pH.....11.7
 Shelf Life (Original Sealed Container)36 months min.
 Calculated VOC0 Grams/liter
 Minimum Application Temperature32°F

Item# **FLK8325** (5 Gal.)

Chemicals

Chemicals - Disinfectants & Antimicrobials

IAQ 6000 - MOLD RESISTANT COATING
Durability Plus Excellent Mold Resistance



IAQ 6000 is a white, tintable mold-resistant coating for professional use, that contains an EPA-registered, broad-spectrum fungicide to prevent mold growth on the surface of the cured film. It is a durable, flexible and permeable 100% acrylic water-based coating that can withstand the moist, humid conditions present in environments conducive to mold growth. It has been tested by independent and certified laboratories to prove resistance to mold growth on the surface of the coating, and has successfully passed both ASTM G-21 and ASTM

D-3273 mold resistance testing with the highest scores possible. IAQ 6000 is recommended to deter mold growth on wood, plaster, wall-board, sheetrock, concrete, masonry block, primed metal and galvanized metal. IAQ 6000 can also be used on new structural materials to help prevent mold growth during building construction.

Specifications

Water Vapor Permeance	3.7 perms
Solids by Weight/Volume ± 2%	54.6%/39.6%
Shelf Life (Original Sealed Container).....	36 months min.
Calculated VOC.....	75 Grams/liter
Coverage.....	Smooth Surfaces, 250-400 ft. ² /gal. Porous Surfaces, 150-300 ft. ² /gal.

Minimum Application Temperature50°F
Item# **FLK8360** (5 Gal.)

AFTERSHOCK FUNGICIDAL COATING
The First Coating EPA Registered To Kill Mold!



AfterShock is an EPA-registered antimicrobial coating designed to kill residual mold and mildew remaining after pre-cleaning contaminated surfaces.

AfterShock also inhibits the future growth and spread of mold and mildew on the cured film surface in residential and institutional buildings. This extremely durable, easy to apply, 100% acrylic sealant offers the ultimate in durability in combination with excellent fungicidal characteristics to address mold growth from water damage.

AfterShock is recommended for use on interior wall surfaces such as plaster, wallboard, drywall, concrete, masonry block, wood, primed metal and galvanized metal. AfterShock is also recommended for use on interior wood framing, primed metal, concrete, and wallboard inside the wall cavity. Do not use for HVAC system applications.

Specifications

Solids by Weight/Volume ± 2%	42.0%/32.7%
Shelf Life (Original Sealed Container).....	36 months min.
Calculated VOC.....	173 Grams/liter
Coverage.....	Smooth Surfaces, 250-400 ft. ² /gal. Porous Surfaces, 150-300 ft. ² /gal.

Minimum Application Temperature50°F
Item# **FLK8390** (1 Gal., 5 Gal.)

IAQ 6100 - MOLD RESISTANT COATING
Durability Plus Excellent Mold Resistance



IAQ 6100 is a clear mold-resistant coating for professional use that contains an EPA-registered, broad-spectrum fungicide to prevent mold growth on the surface of the cured film. IAQ 6100 is a durable, flexible and permeable 100% acrylic water-based semi-gloss coating that applies white so the user can ensure complete and thorough application, and then dries to a clear finish. The clear coating allows surfaces to retain their natural look and permit future visual inspection of the coated surfaces. IAQ 6100 has been tested by

independent and certified laboratories to prove resistance to mold growth on the surface of the coating, and has successfully passed ASTM G-21 mold resistance testing with the highest scores possible. IAQ 6100 is recommended to deter mold growth on wood, plaster, wallboard, sheetrock, concrete, masonry block, primed metal and galvanized metal. IAQ 6100 can also be used on new structural materials to help prevent mold growth during building construction.

Specifications

Water Vapor Permeance	3.7 perms
Solids by Weight/Volume ± 2%	28.8%/25.8%
Shelf Life (Original Sealed Container)	36 months min.
Calculated VOC	90 Grams/liter
Coverage	Smooth Surfaces, 350-600 ft. ² /gal. Porous Surfaces, 250-300 ft. ² /gal.

Minimum Application Temperature50°F
Item# **FLK8361** (5 Gal.)



24-7 MOLD & MILDEW RESISTANT COATING

Inhibits growth of bacteria, mold and mildew that cause stains and odors on the dried coating film – 24 hours a day, 7 days a week.



SENTINEL 24-7 is a low-odor, high-performance coating with Microban® antimicrobial product protection, designed to inhibit the growth of stain and odor causing mold, mildew, and other microorganisms on the coating film. 24-7 can be used on multiple surfaces including, but not limited to, previously painted surfaces, wood, concrete, drywall, plaster, brick and most metals. For those surfaces that require a primer, 24-7 is self-priming and a light precoat will prime these surfaces.

Item# **SEC247-W**

Chemicals - Disinfectants & Antimicrobials



MICROBAN DISINFECTANT SPRAY PLUS

Protects against germs and odors on virtually any surface.



Microban's antimicrobial action kills allergy and disease-causing germs, bacteria, fungi, mold and mildew. Suitable for use on carpets, upholstery and mattresses, Microban Disinfectant Spray Plus is used for decontamination applications including sewage backups, removal of carcasses, and more.

Water-based, deodorizing and antimicrobial, Microban Disinfectant Spray Plus kills gram negative bacteria encountered in sewage backups and toilet overflow situations. Disinfectant Spray Plus is also available in a fragrance-free version.

(Not available in California)

Specifications

Formulation	Ready-to-use
Sold in	4 one-gallon (3.8L) bottles/case, 5 gal. pails, 55 gal. drums
Flash point	102° F 38.9° C
Appearance	Milky white liquid
pH	6.5-7.5
Specific gravity	0.97
EPA registration No.	70385-5
Item#	UNS221522000

BOTANICLEAN® FROM MICROBAN

Antimicrobial/cleaner made with a unique thymol blend



With BotaniClean® less is more!

- No PPE required.
- Clean, disinfect and deodorize in one easy step.
- EPA Category IV rating, which means no "warning" or "danger" labels required.
- No extraneous oils for a consistent, effective product every time.
- No additional rinsing or wiping required.
- Approved for use on food contact surfaces.
- Mild, pleasant fragrance without harsh fumes.
- Ready-to-use convenience – economical!

Microban BotaniClean is a germicide, tuberculocide, fungicide, virucide, broad-spectrum hospital-grade disinfectant ... all in one unique formulation!

BotaniClean kill-claims include:

- Tuberculosis
- MRSA
- H1N1
- HIV
- Gram positive and gram negative microorganisms

Specifications

Formulation	Ready-to-use
Sold in	4 one-gallon (3.8L) bottles/case
Appearance	Opaque clear liquid
pH	3.5±0.5
Specific gravity	1.03-1.00 (H ₂ O = 1)
EPA registration No.	34810-25-70385
Item#	UNS224002000

MICROBAN DISINFECTANT SPRAY PLUS FRAGRANCE FREE

Ideal for treating air ducts or wherever a fragrance-free disinfectant is required.



Disinfectant Spray Plus Fragrance-Free is a powerful bacteriostat, fungistat and deodorizer. It's the one product that's right for multiple applications – water damage restoration, mold remediation and even for use in HVAC systems.

This fragrance-free formulation is ideal for use in HVAC ducting or wherever the use of the scented version is inappropriate. It's economical, too – one gallon treats up to 1,000 square feet of surface. Use of this product on water losses is recognized by major insurance companies.

(Not available in California)

Specifications

Formulation	Ready-to-use
Sold in	4 one-gallon (3.8L) bottles/case, 5 gal. pails, 55 gal. drums
Flash point	102° F 38.9° C
Appearance	Milky white liquid
pH	6.5-7.5
Specific gravity	0.97
EPA registration No.	70385-5
Item#	UNS221522902

MICROBAN X-590 INSTITUTIONAL SPRAY

Water-based bactericide, fungicide, deodorant and insecticide with tracer



Just one application of the Microban X-590 kills nuisance insects, mold, mildew and bacteria odors. It's registered for use on soft surfaces, including mattresses, so it's perfect for combating bed bugs. X-590 is also suitable for many decontamination applications including sewage backups, removal of carcasses and more.

As an insecticide, Microban X-590 kills roaches, lice, fleas, ants, beetles, bed bugs and their larvae. And as a bactericide, Microban X-590 kills gram negative bacteria typically encountered in sewage backups and toilet overflow situations, and is EPA-registered for spray application. Microban

X-590 Institutional Spray includes a tracer, which is especially important when proving compliance with local regulations for mattress treatment. (Not available in Canada)

Specifications

Formulation	Ready-to-use
Sold in	4 one-gallon (3.8L) bottles/case, 5 gal. pails
Flash point	77° F 25° C
Appearance	Transparent yellow liquid
pH	6.5-7.5
Specific gravity	0.9
EPA registration No.	70385-4
Item#	UNS221552000

Chemicals - Disinfectants & Antimicrobials

MICROBAN MILGO PLUS
Disinfectant Cleaner and Sanitizer Concentrate

Microban Milgo Plus inhibits the growth of mold and mildew and handles tough odors like urine, sewage and perspiration. A safe, one-step hospital-grade disinfectant cleaner, designed specifically for the needs of water damage restoration. Sanitizes porous and nonporous surfaces, and can be used for general cleaning and disinfection.

Manufactured exclusively for Dri-Eaz by Microban, Milgo Plus is a professional strength disinfectant cleaner that kills Methicillin-resistant Staphylococcus aureus (MRSA) and protects against a wide range of other bacteria, viruses and fungi. Milgo Plus kills Hepatitis C, Pseudomonas, Legionella, HIV-1 and many other potentially dangerous microorganisms – making it the ideal disinfecting tool anywhere cross-contamination is a concern. EPA-registered (#70385-6).



Features

- Intense cleaning power.
- Sanitizes porous and nonporous material.
- No added fragrance or color.
- Profitable! 64 applications per bottle.

Item# **DRIF447**

FOSTER® 40-51™ MOLD RESISTANT CLEAR COAT



Foster® 40-51™ Mold Resistant Clear Coat has a low viscosity, which allows it to be easily applied by hand or with virtually any type of airless spray system. It works well on a wide variety of surfaces: wood, painted surfaces, wall board, masonry surfaces, metal. Foster 40-51 appears white when wet, but dries to a clear finish.

Because the original condition of the surface is visible and not hidden behind a coating, industrial hygienists, consultants and building owners will be able to

confirm that surfaces were clean prior to inspection. Ideal for a variety of applications: industrial, commercial, residential, hospitals, schools, food processing plants.

Over time, Foster 40-51 will be highly resistant to staining caused by chemicals, mold or mildew. The formulation is based upon a durable acrylic polymer and contains blocking agents to help protect it from UV degradation. It also has excellent water resistance and will not blush once fully cured.

Item# **FOS4051**

FOSTER® FIRST DEFENSE™ 40-80



Foster® First Defense™ 40-80 is an EPA Registered formulation, a full strength disinfectant, and comes in a convenient ready-to-use dilution. Foster First Defense 40-80 has been evaluated in the presence of 6% serum by the AOAC Use-Dilution test and found to be effective against broad spectrum of gram-negative and gram-positive organisms. Foster First Defense 40-80 is ready-to-use and does not require end-users to work with a corrosive or dangerous

concentrate. Foster First Defense 40-80 comes full strength for effective and economical use. Concerns about under dilution or excess material disposal are eliminated.

Item# **FOS4080**

FOSTER® 40-20™ FUNGICIDAL PROTECTIVE COATING



Foster® 40-20™ Fungicidal Protective Coating is the industry's leading EPA registered, antimicrobial coating for HVAC duct systems with ten years of proven effectiveness. It is formulated to effectively prevent the spread of mold and odor causing bacteria on its surface in areas, such as walls, ceilings, pipes and interior/exterior surfaces of HVAC duct systems.

This product is a polyacrylate copolymer emulsion specifically formulated for long-term fungicidal activity, with no loss of

activity on aging. Its tough, elastic, decorative finish is resistant to most industrial chemicals and it is ultra-flexible to allow for movement without splitting, which prevents lodging places for bacteria – making it ideal in industrial and institutional settings.

Item# **FOS4020**

FOSTER® FULL DEFENSE™ 40-25



Foster® Full Defense™ 40-25 is the ideal coating for commercial and residential mold remediation projects. It is the ONLY EPA registered fungicidal coating that kills residual mold and mildew, and protects building materials from the re-growth of mold. Foster 40-25 is a high-coverage, breathable coating with long-term fungicidal activity.

Item# **FOS4025**

Chemicals - Disinfectants & Antimicrobials

ADVANCED CLEANING SOLUTION



The Advanced Cleaning Solution is a patented cleaning product and the cornerstone in the Anabec System of products. When coupled with mechanical action for maximum material penetration, this clear formula removes organic debris left by microbial organisms. The product leaves an extremely clean surface that can then be treated with a microbial barrier or penetrant product such as Anasphere or X-70 Plus.

Features

- 5 Gallons of **Ready to use** product.
- Neutral pH.
- Suitable for finished and unfinished surfaces.
- Low viscosity.
- Applied via sprayers, foggers or by hand.

Item# **ANA1020**

anaSPHERE



Anasphere represents the next generation in hygiene technology. It is a concentrated non-toxic disinfectant, sanitizer and deodorizer, proven to eliminate and protect thousands of surfaces from a variety of microbial organisms including Aspergillus niger, H1N1, E.coli, Influenza, Listeria, Salmonella, MRSA, HIV-1 and many more. The disinfectant in Anasphere

is coupled with an organic polymer that provides long term staying power, so surfaces stay cleaner long.

Features

- 6 (3 oz.) Packets make 30 gallons of **ready to use** product.
- **Concentrate.**
- Cost effective.
- Suitable for finished and unfinished surfaces.
- Applied via sprayers, foggers or by hand.
- EPA Register disinfectant.

Item# **ANA2000**

anaFRESH



anaFRESH is a highly concentrated deodorizer that is a safe and effective tool for eliminating the toughest odors. The concentrate is designed to target and completely neutralize the odors left behind by fires, smoke, flooding, mold and mildew. anaFRESH is formulated with a proprietary blend of Biodegradable essential oils, is water soluble and has a neutral pH. The product is safe for use on all types of finished and unfinished building materials, furnishings and textiles.

ANABEC'S x70



Anabec's x70 is a microbial barrier product specifically designed for application to unfinished building surfaces, including wood fibers, brick, block and unfinished drywall, following mold remediation. The product uses nano-technology which allows the silver active ingredients in x70 to penetrate a materials surface.

Features

- 5 Gallons of **Ready to use** product.
- Surface penetrant.
- Suitable for unfinished surfaces.
- Applied via airless sprayers, rollers or brush.

Item# **ANA3050** (Clear)

Item# **ANA3060** (White)

Item# **ANA3070** (Blue)

newBUILD



Anabec's newBUILD is a microbial barrier product specifically designed for application to NEW unfinished building surfaces, including wood fibers, brick, block and unfinished drywall. The product uses nano-technology which allows the silver active ingredients to penetrate a materials surface.

Features

- 5 Gallons of **Ready to use** product.
- Surface penetrant.
- Suitable for unfinished surfaces.
- Applied via airless sprayers, rollers or brush.

Item# **ANA4050** (Clear)

Item# **ANA4060** (White)

Item# **ANA4070** (Blue)

Features

- **Concentrate** – 32 ounces make 8-16 gallons of **ready to use** product.
- Non-toxic.
- Can be added to most cleaning chemicals as a deodorizing aid.
- Biodegradable Essential Oils.
- Cost effective.

Item# **ANA7000**

Chemicals - Disinfectants & Antimicrobials

SPORICIDIN® DISINFECTANT SOLUTION



Cleans, disinfects, deodorizes. Effective against MRSA, VRE and Avian Influenza A Virus (H9N2 and H1N1). Continuous residual bacteriostatic activity against odor-causing bacteria for up to 6 months, if not removed from surfaces. Compatible with plastics, treated wood, glass, glazed porcelain and glazed tile. Alcohol-free Sporicidin Disinfectant is non-staining, non-abrasive and non-corrosive. EPA registered; OSHA compliant. Lowest EPA toxicity category. Sporicidin has the most neutral pH of any phenolic based disinfectant.

Item# **SPORRE-1284C**

**SPORICIDIN® DISINFECTANT WIPES
12" x 9.5" (30.5cm x 24cm)**



Cleans, disinfects, deodorizes. Effective against MRSA, VRE and Avian Influenza A Virus (as well as H9N2). Continuous residual bacteriostatic activity against odor-causing bacteria for up to 6 months, if not removed from surfaces. Compatible with plastics, treated wood, glass, glazed porcelain and glazed tile. Alcohol-free Sporicidin Disinfectant is non-staining, non-abrasive and non-corrosive. EPA registered; OSHA compliant. Lowest EPA toxicity category. Sporicidin has the most neutral pH of any phenolic based disinfectant.

Item# **SPORJUM-8506C**

BENEFECT®

The First and Only Broad Spectrum Botanical Disinfectant Available on the Market Today



Benefect® is a 100% Botanical Disinfectant – less toxic than vinegar, yet capable of killing over 99.99% of germs.

Excellent Efficacy

- Broad spectrum disinfectant – kills over 99.99% of germs: Bacteria, Fungi, TB, HIV-1 virus, H1N1 virus and odor causing microorganisms.
- Germs DO NOT build up a resistance to the antimicrobial action of Benefect.

Safe Around Food

- Food grade ingredients – unprecedented safety profile:
 - Ingredients listed as Generally Recognized as Safe (GRAS) or as Food Additives by the FDA

- EPA Category IV toxicity – the safest rating allowed
- Non hazardous by OSHA / WHMIS criteria.

- No Cautions or Warning Statements on the label.
- No unnecessary chemicals or fragrances.
- No rinse or wipe required.
- No personal protective equipment necessary.
- No special handling or waste disposal instructions.
- Botanical and pure ingredients – Thyme Oil.
- Ready-to-use formula.

Environmentally Friendly

- Made from 100% Botanical, pure, renewable, patented plant extract ingredients.
- Biodegradable.
- No synthetic fragrances, dyes, ammonia or chlorine.
- Certified by the Environmental Choice Ecology Program.

Item# **BENDISINF** (1 Gal.)

BRU-CLEAN TBC™ – Effervescent Disinfectant Tablets



Bru-Clean Tbc is a unique pre-measured tablet that can simplify your infection control procedures. This one-product solution cleans, disinfects and deodorizes hard, nonporous surfaces. Effective against a wide range of micro-organisms. Use in place of corrosive bleach or harsh phenolic disinfectants. Bru-Clean Tbc is effective, yet safer – its active ingredient, sodium dichloroisocyanurate (NaDCC), is used worldwide to purify drinking water.



Uses:

- Hospitals / Nursing homes
- Medical and dental offices
- Clinics
- Operating rooms
- Isolation wards
- Medical research facilities
- Day care centers and nurseries
- Animal care facilities
- Animal life science laboratories
- Kennels / Pet shops
- Breeding/grooming facilities
- Zoos / Pet animal quarters
- And other animal care facilities.

Specifications

Typical Dilution.....1 Tab/Gal
Working pH.....6.0
Color.....Light Orange
Odor.....Slight Chlorine
Hlth Rtnng (In-Use).....1

Item# **BRU16105-88** (270 Tablet Tub, 2/Cs)

- **One-Product Solution** – Cleans and Disinfects.
- **Effective Against a Wide-Range of Pathogenic Micro-Organisms.**
- **Less Corrosive than Harsh Bleach and Phenolics.**
- **Safer Active Ingredient.**

EXPERIENCE THE DIFFERENCE

Chemicals - Odor Control

SMOKE & ODOR DESTROYER



MAX[®] PRO-CLEAN[™] Smoke & Odor Destroyer is a professional strength odor destroyer used to eliminate odors caused by smoke (fire or tobacco), spills, mold and mildew, sewage back-ups and most acidic odors. Use as a contact cleaner, odor control additive, or in fogging applications to destroy airborne odors. It is non-flammable and contains no hazardous ingredients.

Item# **MAX8311**

SMOKE & ODOR ENCAPSULANT



MAX[®] PRO-CLEAN[™] Odor Encapsulant is a low-odor, fast-drying encapsulant designed to seal surfaces and trap odors like smoke while providing antimicrobial protection on the dried encapsulant surface.* MAX8312 can be applied using brushes, rollers or spraying equipment.

*This encapsulant contains a fungistatic agent which inhibits the growth of mold and mildew on the dried surface of the encapsulant.

Item# **MAX8312-5**

ODOR ELIMINATOR TUB



If you need to eliminate strong odors due to fire and water damage, the Max Odor Eliminator Tub is the product for you – a scientific break-through in clean air methodology with a fresh scent. It sponges up unwanted air contaminants, acting like synthetic charcoal. Its magnetic sponge attracts and deactivates the harmful pollutants in the air. Just place the uncapped tub into the return side of the air conditioner and Max Odor Eliminator will be effective while it dissolves (approximately 3 months). It has years of shelf life as long as container is kept closed.

Item# **MAX8314** (16 oz. Tub)

Item# **MAX8315** (80 oz. Tub)

Don't see what you are looking for? Ask your Abatix Sales Representative. Abatix carries tens of thousands of products. We will make sure you get what you need, when you need it, where you need it.

ODORX[®] 9-D-9[™]

A highly-concentrated general purpose odor counteractant.



9-D-9 is a general purpose smoke odor counteractant specially formulated to manage fire, smoke and other strong odors. Blended with the finest-quality ingredients, 9-D-9 helps to detoxify and knock down malodors fast and efficiently.

It is important that the solution come in direct contact with all contaminated surfaces that might be a source of odor. This provides an initial reduction of strong, objectionable odors.

Specifications

FormulationConcentrate
 Sold in4 one-gallon (3.8L) bottles/case
 Flash point.....81° F | 27.2° C
 Appearance.....Clear amber liquid
 pH.....7.7
 Specific gravity.....0.94

Item# **UNS431002000**



ODORX C.O.C.[™] COMMERCIAL

Powerful granular odor absorbent – effective against sewage, putrefaction, and more.



Crystal Odor Counteractant (C.O.C.) combines chemical odor neutralizers and natural absorbents in a long-lasting ready-to-use dry deodorizer that's effective against sewage, putrefaction, and more.

C.O.C. is a blend of odor control essential oils and evaporative control agents that are immobilized on a solid, absorbent time-release crystal. C.O.C. Commercial is packaged in bulk form. C.O.C. can be sprinkled across the floor, placed in an HVAC system or inserted into difficult to reach areas such as insulation, attics and crawl spaces, and above suspended ceilings.

Specifications

FormulationReady-to-use
 Sold in4 one-gallon (3.8L) bottles/case
 AppearanceBlack and beige granules
 Specific gravity.....approx. 2.5

Item# **UNS431502901** (Cherry)

Continued on next page

Chemicals - Odor Control

(Continued)

ODORX THERMO-55™

Powerful heat-activated odor counteractant.



Utilizing a blend of highly purified petroleum solvents and odor-controlling essential oils, Thermo-55 creates a vapor barrier that prevents malodors from finding their way into the living environment. Solvent-based and available in a wide range of pleasant scents, Thermo-55 is especially effective for controlling odors associated with structural fires. It is also highly effective for tobacco-related odor removal.

Specifications
 Formulation Ready-to-use
 Sold in 4 one-gallon (3.8L) bottles/case
 Flash point 154° F | 67.7° C
 Appearance Clear light yellow liquid
 Specific gravity 0.79
 Item# **UNS433002901** (Cherry)



ODORX BAD ODOR BLOCKS™

Easy-to-use odor counteractant.



The Bad Odor Block is a simple, convenient method to quickly suppress odors in virtually any location. Available in a wide variety of pleasant scents, the natural wicking block starts dispensing when the sealed package is opened. The Bad Odor Block media holds

more than three times its weight in active ingredients for long lasting deodorization.

Place Bad Odor Blocks in vents, ducts, airmovers, automobiles – anywhere odor control is required.

Specifications
 Formulation Ready-to-use
 Sold in cases 25 blocks/case
 Flash point 160° F | 71.1° C
 Appearance Brown colored fiber block
 Dimensions (WxHxD) 2¾" x 3¾" x ½" (7cm x 9.4cm x 1.3cm)
 Item# **UNS431254901** (Cherry)

MICROBAN MILGO SR
 Deodorizer concentrate

Milgo SR is your best choice for deodorizing stain-resistant carpets. Manufactured exclusively for Dri-Eaz by Microban, Milgo SR deodorizes porous materials like carpet, pad, sub-floors, drywall, upholstery and other affected materials. Add Milgo SR to the laundry to deodorize fabrics in the washing machine!

Each bottle makes up to 16 gallons of deodorizing solution.



Features

- Formulated for stain-resistant carpets.
- Handles tough odors like urine, feces, perspiration and decay.
- Fresh, lemon scent.
- Concentrated! Makes up to 16 gallons of solution.

Item# **DRIF448**

Chemicals - Cleaner/Degreaser



CARPET EXTRACTION CLEANER



MAX® PRO-CLEAN™ Carpet Extraction Cleaner is a biodegradable, professional strength carpet cleaner, formulated for use in extraction equipment to clean carpet and other washable fabrics and soft goods. MAX8301 is low foaming.

Item# **MAX8301**

ENZYME CLEANER



MAX® PRO-CLEAN™ Enzyme Cleaner is a professional strength cleaner used to clean hard or unknown stains from hard surfaces, as well as carpets and washable fabrics. Remove biological stains like urine, soda, vomit, inks, blood, alcohol, coffee, pet stains, wine and burnt food soils. Use for contact cleaning or as a pretreater when using carpet extraction cleaners.

Item# **MAX8313**

Continued on next page

EXPERIENCE THE DIFFERENCE

Chemicals - Cleaner/Degreaser

CONCENTRATED GENERAL PURPOSE CLEANER & DEGREASER



MAX PRO-CLEAN™ Concentrated General Purpose Cleaner & Degreaser cleans up a variety of stains, spills and messes from most surfaces, without the use of harmful, hazardous ingredients. MAX8304 is highly concentrated so it can be diluted on site to best meet the needs of any given cleaning situation. It can be applied for contact cleaning using buckets or via low and high-pressure spraying.

Item# **MAX8304-1** (1 Gal.)

Item# **MAX8304-5** (5 Gal.)

CONCENTRATED GLASS CLEANER



MAX® PRO-CLEAN™ Concentrated Glass Cleaner is designed to clean glass and leave a streak-free shine. This product releases dirt from the glass, dries quickly and eliminates drag during wiping.

Item# **MAX8306**

SMOKE & SOOT WASH



MAX® PRO-CLEAN™ Smoke & Soot Wash is a professional strength, highly concentrated cleaner built to clean a variety of surfaces while being very safe to use. Use for contact cleaning or low and high-pressure spray cleaning to remove residues found after fires and other disasters like soot, smoke and other soils. MAX8309 can be diluted up to 10:1 with water.

Item# **MAX8309**

SIMPLE GREEN



All-Purpose Industrial Strength

Cleaner/Degreaser – Removes oil and grease from washable surfaces. Can be diluted for light to heavy cleaning needs. Use for pressure washing and steam cleaning, maintenance, food processing and preparation, and parts washing. Exempt from OSHA and EPA special handling and personal protection requirements. Biodegradable, nontoxic, nonabrasive, nonionic and nonflammable. VOC compliant. NSF/USDA Classifications A4 and A8.

Item# **LAGSMP13005** (1 Gal.)

UNSMOKE DEGREASE-ALL™

Tough solvent cuts through the heaviest grease and oil residues.

Degrease-All is tough enough to remove heavy residues, but gentle enough to be used as a traffic lane cleaner or upholstery pre-spray. A general-purpose cleaner, Degrease-All is highly effective on particulate and greasy soils, and can be used on most hard surfaces. No intoxicating fumes.



Specifications

Formulation.....Concentrate
Sold in cases4 one-gallon (3.8L) bottles
Flash point219° F | 103.8° C
Appearance.....Clear blue liquid
pH12.3
Specific gravity1.034

Item# **UNS161252000**

ATOMIC FIRE & SOOT CLEANER



Benefect's Atomic Cleaner is a heavy-duty cleaner and degreaser concentrate based on next-generation dynamic chemistry that dramatically outperforms the competition without using hazardous synthetic chemicals.

Formulated to seek and remove particulate at the atomic level with minimal agitation.

Made from botanically-based ingredients, it is readily biodegradable and safe to use around children, pets and the chemically-sensitive.

Item# **BENATOMIC** (1 Gal.)



Chemicals - Lead Abatement

PIRANHA 2 - HEAVY-DUTY PAINT REMOVER
Fast Acting Lead-Based Paint Remover



Piranha 2 quickly removes the most difficult oil and latex paints, varnishes, shellacs, lacquers and enamels.

Piranha 2 professional paint remover attacks multiple layers of lead-based paint in a single application.

Piranha 2 is non-flammable and will not raise the grain of wood or corrode metals. This product does not require anti-evaporation paper like many caustics and other weaker solvent formulas.

Brush application recommended.

Caution: Contains methylene chloride.

Specifications

Color / Odor Clear hazy / Pungent odor

Flash Point > 212°F

Shelf Life (Original Sealed Container) 36 months min.

Weight Per Gallon 9.6 lbs./gal.

Coverage: Non-Porous Surfaces, 100 ft.²/gal.
Porous Surfaces, 50-100 ft.²/gal.

Specific Gravity 9.58 lbs./gal.

Activation Time 5-15 min.

Minimum Application Temp 40°C

Item# **FLK5720** (5 Gal.)

PIRANHA 4 - SOLVENT GEL PAINT REMOVER
Lemon Scented, Fast Acting and Easy to Use



Piranha 4 is a solvent-based gel formulated to remove multiple layers of lead-based paint.

Piranha 4 starts removing most paints and stubborn coatings in less than one hour, without the use of dangerous chlorinated solvents, caustics or methylene chloride.

Piranha 4 has a unique gel formulation that yields maximum coverage per gallon and provides excellent resistance to sagging, enabling it to cling to vertical and overhead surfaces.

Piranha 4 has a very slow rate of evaporation keeping it active for hours. Piranha 4 is a unique solvent formulation ideally suited for paint removal from historically significant architectural components since it does not discolor or raise wood grain or require neutralization. Piranha 4 can be used on virtually any substrate to remove oil based paint, latex paint, elastomeric paint, cementitious asbestos paint, epoxy and urethane.

Specifications

Color / Odor Blue / Mild solvent odor

Flash Point > 212°F

pH 7.0-8.0

Shelf Life (Original Sealed Container) 36 months min.

Weight Per Gallon 12.35 lbs./gal.

Coverage: Smooth Surfaces, 125 ft.²/gal.
Porous Surfaces, 50-100 ft.²/gal.

Item# **FLK5740** (5 Gal.)

PIRANHA 8 - ALKALINE PASTE PAINT REMOVER
Liquefy Paint on a Variety of Substrates



Piranha 8 is a heavy-duty, caustic paint remover, particularly well suited for removing lead based paint.

Piranha 8 removes most paints, varnishes, polyurethanes and water-based latex paints from metal, stone, concrete, marble, plaster wall, ceiling and decorative plaster – remove over 30 layers of paint safely and easily in a single application. It is particularly well suited for stripping lead-based paint including red lead primer found on steel.

Surfaces must be neutralized after using Piranha 8.

Specifications

Color / Odor White paste / Odorless

Flash Point Non-combustible

pH 12.0+

Shelf Life (Original Sealed Container) 36 months min.

Weight Per Gallon 12.35 lbs./gal.

Coverage: 1/4" Coat, 6.4 ft.²/gal.
1/8" Coat, 12.8 ft.²/gal.
1/16" Coat, 25.6 ft.²/gal.

Item# **FLK5780** (5 Gal.)

LBC - LEAD BARRIER COMPOUND (Type III - Interior/Exterior)
Avoid Costly Removal of Lead Based Paint by Using LBC



LBC is accepted in all 50 states as a permanent lead abatement method. (ASTM E-1795)

LBC is a thermoplastic-elastomeric water based copolymer blended specifically to form a barrier between lead based paint and the environment. It is a high-solids coating formulated to offer unparalleled coverage, economics and aesthetics while preserving historic and architectural detail. LBC contains Bitrex[®], a bitter-tasting, nontoxic ingredient to discourage oral contact with lead paint. LBC Complies with all EPA and HUD requirements for lead based paint encapsulation.

LBC can be applied to the proper thickness in one application with most major brands or airless spray equipment, by brush or roller.

Specifications

Color White

Solids by Weight/Volume ±2% 59.0%/45.0%

Viscosity at 70°F 95-120 Kreb Units

Specular Glass 5.5° ± 1 @60°

Flash Point Non-combustible

Shelf Life (Original Sealed Container) 24 months min.

Weight Per Gallon 11.24 lbs./gal.

Coverage: Non-porous Surfaces, 120 ft.²/gal.
Porous Surfaces, 80-120 ft.²/gal.

Minimum Application Temperature 50°F

Item# **FLK5801** (5 Gal.)

Chemicals - Lead Abatement

**PEEL AWAY® 1
Complete Paint Removal System**



Peel Away® 1 Complete Removal System is excellent for stripping paint from intricate, carved or molded surfaces, and is highly recommended for historic restorations and other projects involving lead-based paint abatement.

Peel Away® Paper keeps paste and paint in a wet or damp state, preventing lead particles from getting into the air or onto the surrounding area. When the fibrous laminated Peel Away® Paper is removed, the bulk of the paste and lead

paint comes off with it for easy disposal. Refer to federal/local regulations for disposal of lead-based material.

Features and Benefits

- One application can remove 30+ coats of paint.
- Formulated without methylene chloride or flammable solvents; does not generate hazardous fumes.
- Non-toxic, non-carcinogenic, and nonflammable; VOC = 0.
- Controls lead-dust dispersal on historic restoration and lead remediation projects.

Item# **DCIPA1**

PEEL AWAY® PAPER

Peel Away® Paper is one of the most respected and widely used environmentally friendly lead-based paint removal products in the world. Each pail is a complete kit that includes gloves, spatula and patented Peel Away® Paper. This paint stripping kit should enable the end user to complete virtually all desired tasks for which Peel Away® is made. However, depending upon your application and project you may find it desirable to purchase additional Peel Away® Paper.

Item# **DCI1124** (11" x 300" roll)

PEEL AWAY® SMART STRIP PRO Paint Remover



Smart Strip™ PRO is a professional strength paint stripper that effectively removes architectural, industrial and lead paints.

Smart Strip™ PRO is formulated to remain wet and effective without the use of Peel Away® Paper. (For extended dwell times, Peel Away® Paper may be necessary, particularly on lead abatement and industrial projects). Dwell time will vary depending on the type of coating, number of layers and temperature.

Features and Benefits

- Safe: Formulated without methylene chloride or caustic, this water-based remover is low-odor and non-flammable.
- Effective: Removes multiple layers of architectural, industrial and lead paints from any interior/exterior surface in single application.
- Environmentally Friendly: Water-based, low VOC, biodegradable.
- User Friendly: Easily applied by brush, roller or conventional airless spray. Does not require neutralization or the use of Peel Away® Paper.

Item# **DCIPA3505**

**PEEL AWAY® 7
Solvent-Based Paint Remover**



A uniquely versatile, environmentally safe lead paint removal system, Peel Away® 7 will remove most varieties of architectural paints and varnishes, as well as high-performance coatings such as epoxies, urethanes, acrylics, elastomers, chlorinated rubber, aluminum, mastics, automotive and marine bottom finishes. Peel Away® 7 can be used as a paint stripper on virtually all interior and exterior surfaces, and is excellent for paint removal on intricate, carved and molded surfaces.

Features and Benefits

- One application removes multiple coats of most lead-based paints, varnishes and high-performance coatings.
- Safe for use on virtually all interior and exterior surfaces.
- Formulated without methylene chloride, caustic or highly flammable solvents, Peel Away® 7 is the best paint remover for the environment and user.
- Non-toxic formula requires no surface neutralization.

Item# **DCIPA7**

**PEEL AWAY® ST-1
Lead Based Paint Remover**



Peel Away® ST-1 has been specifically formulated for heavy-duty removal of lead-based paint from steel structures such as tanks, bridges and structural members. Peel Away® ST-1 is similar to Peel Away® 1 however its self-sealing characteristic allows it to continue working in a moist environment without requiring any Peel Away® cover. Coverage is 20 sq. feet per gallon.

Since Peel Away® ST-1 is keeping the lead paint in a damp state, minimum containment is required. Average waste

generated by using Peel Away® ST-1 for lead paint removal is 1-55 gallon drum for every 1200 sq. feet.

Item# **DCIPAST1**

PEEL AWAY® SMART STRIP™



Smart Strip™ is a revolutionary paint remover that is safe for the user, the substrate and the environment. The Smart Strip™ Paint Removal System is a 100% biodegradable, water-based paint stripper that is extremely effective for removing multiple layers of architectural and industrial coatings from virtually all interior/exterior surfaces such as wood, brick, metal, concrete, stone, plaster, fiberglass, etc. Smart Strip™ does not contain methylene chloride, any caustics, or toxic

chemicals. It is odor-free and safe for the environment.

Item# **DCIPA3305**





Chemicals - Lead Abatement

805 ENVIROWASH



SENTINEL 805 is specifically formulated and highly concentrated. It has been designed to meet both HUD Guidelines and Phosphate rules for Maryland and New York.

It can be used for lead clean-up and for final surface preparation of sub-floors following mastic removal on asbestos abatement jobs. 805 has excellent cleaning capabilities and can be diluted up to 1:20 with clean water.

Item# **SEC805**

ET ENVIROTOWELS



SENTINEL ENVIROTOWELS represent the latest technology in cleaning and removing lead dust. Towels are designed for pre-cleaning prior to removal or encasement of lead and for final clean-up following lead abatement. Each towel is ready-to-use and presoaked with a solution of Sentinel 805 Envirowash. Envirotowels meet USEPA Title 40, Part 745 definitions and work practice standards for "wet disposable cleaning cloth" and "dry disposable cleaning cloths."

ET Envirotowels are packed in sealed dispensing containers keeping each towel clean and ready to use while eliminating cross-contamination of lead dust.

Item# **SECET/90** (90 Count)
(8" x 12" towels ready for handwiping and cleaning up lead dust.)

Item# **SECET/290** (290 Count)
(9" x 14" towels ready for use on the big jobs or when multiple crews are working.)

LEDIZOLV® CLEANER



**Home Owners
Health Departments
Facility Managers & Owners
Contractors, Architects
& Consultants**

Ledizolv® is a scientifically formulated lead-specific detergent intended for use in the clean-up and control of lead-contaminated dust (LCD) hazards during post abatement cleaning and in-place management activities.

Features

- Reduces LCD hazards to make homes lead-safe.
- Superior to TSP in removing LCD.
- Reduces clearance failures by 95% and more.
- Used worldwide by abatement contractors.
- Referenced in the HUD Guidelines.
- Proven effective on all surface types.
- Excellent health-safety characteristics.
- Phosphate-free and biodegradable.
- Highly concentrated (mixes 50:1 w/water).

Item# **LSZ1G**



EXPERIENCE THE DIFFERENCE

Chemicals - Asbestos Abatement

FIBERSET PM - POST REMOVAL SURFACE SEALANT UL Classified Post Removal Surface Sealant



Locks down residual asbestos fibers to help ensure final air clearance.

After asbestos is removed, spray Fiberlock PM Lockdown on the newly exposed beam or deck assembly.

One coat of this competitively priced, premixed lockdown traps all microscopic asbestos fibers left on the surface and ensures final air clearance.

Fiberlock PM is a pre-mixed "lockdown" sealing treatment for microscopic residual asbestos fibers present after the removal of Asbestos Containing

Material (ACM). Fiberlock PM is a ready-to-use, Class "I" fire-rated coating that provides a flexible barrier over residual asbestos fibers to ensure final air clearance. Fiberlock PM is UL[®] classified for use as a primer for fireproofing replacement materials under the "Encapsulant Materials" section of the UL directory, and is compatible with most leading brands of flooring adhesives. Fiberlock PM is a water-based, nontoxic coating that employs advanced 100% acrylic resin technology to extend the life expectancy of airless spray equipment.

Specifications	
UL Classification	ASTM E-119
UL Category	Encapsulant Materials
Solids by Weight ±2%	11.0%
Solids by Volume ±2%	8.9%
Viscosity at 70°F	55-60 Krieb Units
Specular Glass	44° ± 3 @60°
Flash Point	Non-combustible
Shelf Life (Original Sealed Container)	36 months min.
Weight Per Gallon	8.6 lbs./gal.
Coverage:	Smooth Surfaces, 500 ft. ² /gal. Porous Surfaces, 350-500 ft. ² /gal.
Minimum Application Temperature	50°F
Drying Times (@ 70-77° F, 50% R.H)	
To Touch	1-2 hours
To Recoat	1-2 hours

- Item# **FLK7470** (5 Gal. - White)
- Item# **FLK7475** (5 Gal. - Clear)
- Item# **FLK7480** (5 Gal. - Blue)

Abatix carries a wide range of disinfectant, antimicrobial, odor control, cleaner, degreaser, lead and asbestos abatement, and mastic remover products. Need help picking the right product for the job? Call your local Abatix sales rep; we are here to help.

FIBERLOCK TECHNOLOGIES

LAG KLOTH - WATER ACTIVATED REPAIR CLOTH Heat Resistant up to 600°F



Lag-Kloth is a woven fabric impregnated with an inorganic adhesive, designed to repair and/or cover existing asbestos insulation on pipes, boilers and breaching.

Areas that are repaired or re-covered with Lag-Kloth can be successfully top coated with Lag-Kote[®] or Lag-Kote II for complete encapsulation.

The self-contained adhesive in Lag-Kloth is water-activated and nonflammable. Lag-Kloth is heat resistant up to 600°F.

Specifications	
Composition	Glass fabric, inorganic adhesive
Thickness / Warp / Fill	0.024 / 100 / 45
Color	White
Fiber Count	18 x 14/sq. in.
Shelf Life (Original Sealed Container)	36 months min.
Weight Per Gallon	14.8 oz./sq. yd.
Coverage (Pail)	75 ft. ²
Coverage (Roll)	750 ft. ²
Drying Times (@ 70-77°F, 50% R.H)	
Hot Insulation	2-4 hours
Cold Insulation	8-12 hours

- Item# **FLK6425** (5' x 15' Rolls)
- Item# **FLK6426** (5' x 150' Rolls)

LAG KLOTH – WATER ACTIVATED REPAIR CLOTH Heat Resistant up to 600°F



Lag-Kloth is a woven fabric impregnated with an inorganic adhesive, designed to repair and/or cover existing asbestos insulation on pipes, boilers & breaching.

Areas that are repaired or re-covered with Lag-Kloth can be successfully top coated with Lag-Kote[®] or Lag-Kote II for complete encapsulation.

The self-contained adhesive contained in Lag-Kloth is water-activated and non-flammable. Lag-Kloth is heat resistant up to 600°F and is available in easy to use 4" x 150' strips.

Specifications	
Composition	Glass fabric, inorganic adhesive
Thickness / Warp / Fill	0.024 / 100 / 45
Color	White
Fiber Count	18 x 14/sq. in.
Shelf Life (Original Sealed Container)	36 months min.
Weight Per Gallon	14.8 oz./sq. yd.
Coverage (Roll)	150 ft. ²
Drying Times (@ 70-77°F, 50% R.H)	
Hot Insulation	2-4 hours
Cold Insulation	8-12 hours
Item# FLK6427	(4" x 150' Rolls)

Chemicals

Chemicals - Asbestos Abatement

ABC - ASBESTOS BINDING COMPOUND
Multipurpose Asbestos Encapsulation System



ABC is an important tool for coping with the health hazards associated with exposure to asbestos fibers.

In 1978, ABC was tested for the EPA under contract #68-03-2552-T2005 by Battelle Laboratories of Columbus, Ohio, and found to meet the requirements for the effective encapsulation and removal of ACM. (ASTM 384 Class A)

ABC is also an effective tool for controlling the documented health hazard of exposure to asbestos fibers found present in soil.

Specifications

Solids by Weight/Volume ±2%	51.4%/44.0%
Viscosity at 70°F	60-75 Kreb Units
Specular Glass	82° ± 5 @60°
Flash Point	Non-combustible
Shelf Life (Original Sealed Container)	36 months min.
Weight Per Gallon	9.6 lbs./gal.
Coverage:	Smooth Surfaces, 50-100 ft. ² /gal. Porous Surfaces, 50-75 ft. ² /gal.

Minimum Application Temperature50°F
 Item# **FLK6421** (5 Gal. - White)

ABC FIBERSPRAY
The Same Great ABC in a Convenient Airless Spray Can



ABC Fiberspray provides the same trusted formula that is found in ABC Asbestos Binding Compound in a convenient airless spray can – ideal for core samples, glove bags and small abatement jobs. (ASTM 384 Class A)

ABC FiberSpray is a convenient means for applying Fiberlock Technologies' proven ABC Asbestos Binding Compound asbestos encapsulant. ABC FiberSpray dispenses encapsulant from a unique 8 ounce airless spray can. This CFC-free airless spray technology minimizes asbestos fiber release, and permits application of encapsulant in any position, even upside down.

Encapsulation of small, hard-to-access areas can be accomplished quickly and easily, without the need for bulky spray equipment.

Specifications

Solids by Weight/Volume ±2%	51.4%/44.0%
Viscosity at 70°F	60-75 Kreb Units
Specular Glass	82° ± 5 @60°
Flash Point	Non-combustible
Shelf Life (Original Sealed Container)	36 months min.
Case Size	12 cans/case
Coverage (Individual Can)	35-40 ft. ² /can
Minimum Application Temperature	50°F

Item# **FLK6410** (8 Oz. - White)

LAG KOTE II – LAGGING ENCAPSULANT
For Interior Lagging and Asbestos Encapsulation



Lag-Kote II is a thick bridging encapsulant/sealant specifically formulated for application over interior friable asbestos containing material (ACM). It is ideally suited to encapsulate interior pipe lagging, boiler jackets, breeching and other components of heating and ventilation systems. Its thick body minimizes dripping, cleanup and product waste while providing a smooth, washable, aesthetically superior finish that will provide years of protection. It can be applied over galvanized metal, wood, masonry or other sound surfaces to prevent the release of harmful asbestos fibers.

Specifications

Solids by Weight/Volume ±2%	52.0%/39.9%
Viscosity at 70°F	120-130 Kreb Units
Specular Glass	45° ± 3 @60°
Flash Point	Non-combustible
Shelf Life (Original Sealed Container)	36 months min.
Weight Per Gallon	10.3 lbs./gal.
Coverage:	Smooth Surfaces, 125-175 ft. ² /gal. Porous Surfaces, 75-100 ft. ² /gal.

Minimum Application Temperature50°F
 Item# **FLK6420** (5 Gal. - White)

PENEWET – WETTING AGENT & SURFACTANT
Keeps ACM Wet for 5 Times Longer than Competitive Products



Spraying with Penewet eliminates the hazard by wetting the ACM and making it safe to handle.

Penewet's chemically advanced wetting/penetrating/binding action saturates the entire mass of ACM. So it's easy to scrape and bag the damp, asbestos containing material without releasing dangerous asbestos fibers.

Penewet is a ready-to-use, colorless wetting agent/surfactant solution incorporating advanced concepts in surface chemistry. It provides powerful wetting,

penetrating and coalescing of Asbestos Containing Material (ACM) to permit handling and removal of these materials under damp, dust-free conditions. Penewet is a nonflammable, water-based, non-toxic liquid that will not corrode aluminum components of spray equipment.

Specifications

Solids by Weight ±2%	10%
Viscosity at 70°F	50-55 Kreb Units
Flash Point	Non-combustible
Shelf Life (Original Sealed Container)	36 months min.
Volatile	Water
Weight Per Gallon	8.8 lbs./gal.
Coverage:	Smooth Surfaces, 500 ft. ² /gal. Porous Surfaces, 300 ft. ² /gal.

Item# **FLK6450** (5 Gal.)

Chemicals - Mastic Removers

**LOW ODOR HIGH PERFORMANCE
MASTIC REMOVER**



Abatix AMR-100 is a Premium, Low Odor, High Performance Mastic Remover designed to remove asphalt cutback adhesives and rinse leaving no residue. When subfloors are dry, new flooring may be confidently installed.

Item# **SECAMR100**
Item# **SECAMR100-CA**
(VOC/CARB Compliant)

ODORLESS HIGH PERFORMANCE ADHESIVE REMOVER



Abatix AMR-145 Odorless High Performance Adhesive Remover is designed to remove asphalt cutback adhesives and rinse leaving no residue. When subfloors are dry, new flooring may be confidently installed.

- Faster acting.
- Greater coverage.
- 100% organic.
- Over 140° flash point.

Item# **SECAMR145**

ODORLESS ADHESIVE REMOVER



Abatix AMR-180 Odorless Adhesive Remover is a biodegradable, fast-acting product ideal for the removal of adhesives, oils, grease, lubricants and other petroleum residues. AMR-180 is a safe alternative to hazardous citrus, terpene and chlorinated based products. When subfloors are dry, new flooring may be confidently installed.

- Odorless and biodegradable.
- Over 180° flash point.

Item# **SECAMR180**



747 FRESH SCENT MASTIC REMOVER



747 is the leader in mastic and cutback adhesive removal. Used by commercial abatement contractors across North America, 747 is a powerful, low-odor product that removes cutback and asphalt-based adhesives, as well as indoor/outdoor carpet glues. 747 cleans up with soap and water, leaving surfaces ready for new flooring.

Item# **SEC747**
Item# **SEC747-CA**
(VOC/CARB Compliant)

909 SOY-BASED MASTIC REMOVER



Sentinel 909 is a biodegradable, soy-based solvent cleaner created for the removal of asphalt-based mastics, adhesives, lubricants, inks and other petroleum-based residues. 909 is slow-evaporating, so it will remain active on the adhesive or residue until washed off, allowing for longer soak times, while providing you and your clients with a bio-based alternative. Clean up with Sentinel 805 Enviowash and allow floors to dry completely before installing new flooring.

Item# **SEC909**

626 CARPET & SHEET VINYL ADHESIVE REMOVER



SENTINEL 626 CARPET & SHEET VINYL ADHESIVE REMOVER is a powerful, biodegradable, formulation designed specifically for quickly removing latex, acrylic and pressure-sensitive adhesives from concrete, terrazzo, ceramic and vinyl tile or wood substrates. Use 626 to remove tan or beige colored glues, linoleum backing and vinyl sheet goods adhesives. 626 cleans up with water, is non-hazardous, and requires no dilution, so it's ready to use.

Item# **SEC626**

Chemicals - Lubricants

WD-40® SMART STRAW® – Smart Straw Sprays 2 Ways.



Now you can use WD-40® to protect and lubricate thousands upon thousands of items – without ever losing the straw again!

New Smart Straw features a permanently attached straw that sprays two ways. Simply flip it up for a precision stream and down for a regular spray action.

Discover how one of the world's smartest products just got smarter.

Never Lose the Straw Again®.

Item# **WD40108** (8 Oz.)
Item# **WD40111** (11 Oz.)

**WD-40® – 3 OZ HANDY CAN
Travel-sized problem-solver.**



You can use WD-40® to protect, clean and lubricate thousands upon thousands of items wherever you go!

All of the handy uses in one small can, the WD-40 3 oz. Handy Can is always ready to tackle your toughest jams. From small to medium sized jobs, never fear, your problem solver is here.

Item# **WD40102** (3 Oz.)

Containment

KONTROL KUBE® ADVANCED SYSTEM
Containment Solutions for Airborne Pathogens

The Kontrol Kube Advanced containment unit incorporates all the elements of the original enclosure and adds new features making it easier to create temporary containment. Durability, flexibility and function have all been increased, making this the most advanced containment enclosure available. The Advanced unit can be used to access both overhead and walls as well as set up as an anteroom to contain larger areas. Manufactured with a NFPA 701 and California Fire Marshal rated synthetic fabric, the Advanced enclosure is over three times stronger than traditional vinyl enclosures.



- Item# **FLK6551** 10' Advanced Mobile Containment Unit
- Item# **FLK6540** 10' Frame
- Item# **FLK6547** 10' Advanced Enclosure
- Item# **FLK6543** Wheel Base



Item# **FLK6543** Wheel Base

KONTROL KUBE® AIRBASE



The patent pending AirBase attaches quickly and easily to the Kontrol Kube Wheel Base and is designed to support a negative air machine. Once connected, the entire system including negative air machine and containment unit can be rolled through a facility by a single person.

Item# **FLK6542**

KONTROL KUBE® TOPSIDER™ SYSTEM
Containment Solutions for Airborne Pathogens

The Kontrol Kube TopSider adjusts to ceilings up to 10' when overhead containment is needed for maintenance or repairs such as cabling, light bulb replacement, HVAC access or any other above ceiling work. The Topsider can also be used for side wall containment when performing work such as plumbing, installing power or communications outlets. For both overhead and sidewall access, a negative air machine in conjunction with the Kontrol Kube provide a negative pressure environment reducing the risks of airborne contamination.



- Item# **FLK6552** 10' TopSider Containment Unit
- Item# **FLK6540** 10' Frame
- Item# **FLK6544** 10' TopSider Enclosure
- Item# **FLK6543** Wheel Base



Item# **FLK6540** 10' Frame

KLEAN-POP SHOWER

The patent-pending Klean-Pop Shower is a revolution in pop-up shower design. When disassembled, the Klean-Pop offers the easy mobility and compact appearance of a suitcase on wheels. One person can move Klean-Pop wherever it needs to be, and set up the shower in as little as 2 minutes. Priced competitively with telescoping designs, and more durable than plastic options, Klean-Pop answers the growing need for a quality decontamination shower that is inexpensive, durable and easy-to-use.

Item# **FLK6439**



Containment

DISPOSABLE ENVELOPE CEILING CAVITY STARTER SET



Disposable Envelopes (DE) provide consistent appearance, cleanliness and performance. A truly affordable solution, these envelopes can be used to standardize compliance with the Infection Control Risk Assessment (ICRA) throughout a facility. Plus they save time and effort.

The lightweight fire retardant DE are recyclable and due to advanced additives, biodegradable. DE set up is easy with the industry leading Mintie frame, repositioning is quick, and tear down is simple. When finished the envelope acts as its own bag, there is no need for post use decontamination.

Specifications

Ceiling Cavity (CC) Frame

- Lightweight, collapsible frame.
- 2-Piece top frame assembly with foam strip.
- Flat floor truss.
- Sturdy, non-skid polyurethane wheels.
- Collapsed dimensions: 10.0" x 10.0" x 62.0"
- Extended dimensions:

Footprint: 58.0" x 28.0"
 Height: 7'6" x 9'5"
 Weight: 45 lbs.



Replacement Envelopes (5 per Pkg.)

Disposable Envelope

- Lightweight, material allows for light transmission.
- Fire Retardant to NFPA 701-04 test 1.
- Air Permeability to ASTM D 737-04 standard.
- Heavy-duty fabric zippers.
- 84" Access Door.
- 20" Zipper NAM port.
- Double loop Velcro straps.
- Integrated tacky mat with anti-slip non-scoot floor.
- Outer package secondary disposal bag w/ zip tie.
- Clear pouch to display work/infection control permit.
- Weight: 2.5 lbs.

Item# **MNTDE3CCF**

Item# **MNTDE-5CC** (Replacement Envelopes)

DISPOSABLE ENVELOPE ECU2 CEILING CAVITY STARTER SET



The ECU2 Disposable Envelope provides reliability and high performance in an affordable, disposable solution for containment standardization. These fire retardant envelopes provide constant appearance, cleanliness and safety.

The lightweight envelopes are easy to put on Mintie's frame, repositioning is quick and tear down is simple. When work is done the envelope acts as its own bag, and the original blue packaging is a second bag for double bagging. There is no need for post use decontamination.

The disposable envelope can also be used as a liner for the ECU2, protecting that investment when completing work which might damage or permanently contaminate the unit, such as caulking for firewall repair or abatement work.

Specifications

ECU2 (CC) Frame

- Lightweight, collapsible frame.
- 2-Piece top frame assembly with foam strip.
- Flat floor truss.
- Sturdy, non-skid polyurethane wheels.
- Collapsed dimensions: 12.0" x 12.0" x 66.0"
- Extended dimensions:

Footprint: 61.0" x 34.0"
 Height: 7' x 10'6"
 Weight: 45 lbs.



Replacement Envelopes (4 per Pkg.)

Disposable Envelope

- Lightweight, material allows for light transmission.
- Fire Retardant to NFPA 701-04 test 1.
- Air Permeability to ASTM D 737-04 standard.
- Heavy-duty fabric zippers.
- 84" Access Door.
- 20" Zipper NAM port.
- Double loop Velcro straps.
- Anti-slip non-scoot floor (inner, outer).
- Outer package secondary disposal bag w/ zip tie.
- Clear pouch to display work/infection control permit.
- Weight: 3 lbs.

Item# **MNTDE3-ECU2F**

Item# **MNTDE4-ECU2** (Replacement Envelopes)



Containment

ECU (Environmental Containment Unit) CEILING CAVITY™



Replacement Envelope

The ECU Ceiling Cavity™ is a collapsible, portable containment unit engineered to control the spread of dust and airborne contaminants when performing building maintenance functions and other projects above the ceiling cavity. Ideal for multiple, quick-entry jobs, it can also be safely secured for longer-term projects. Its single unit, standardized size makes it a clear, convenient alternative to poles and plastic sheeting. The operator simply wheels it into position, extends and secures against the ceiling. Paired with a HEPA-filtered negative air machine, the ECU Ceiling Cavity™ provides total compliance and is ready to begin work.

Specifications

Frame

- Lightweight, collapsible frame.
- 2-Piece top frame assembly with foam strip.
- Flat floor truss.
- Sturdy, non-skid polyurethane wheels.
- Collapsed dimensions: 10.0" x 10.0" x 62.0".
- Extended dimensions:
Footprint: 58.0" x 28.0"
Height: 7'6" x 9'5"
Weight: 45 lbs.

Envelope

- Lightweight, durable CA State Fire to U.S. NFPA 701 standard.
- One 20.5" door.
- Two clear panel windows: 14.0" x 40.0".
- Two negative air machine ports.
- 11.0" Round port with drawstring and seal.
- 3.5" Round HEPA vacuum port with draw string and seal.
- Double-reinforced floor.
- Clear pouch to display work/infection control permit.
- Weight: 15 lbs.

Item# **MNTECU-CC**

Item# **MNTECU-CCE** (Replacement Envelope)

ECU2 (Environmental Containment Unit)

The modular ECU2 is a collapsible, portable containment unit for temporary isolation during normal facility operation or during a public health emergency. Designed to be a multi-functional containment solution to help organizations maximize their return on investment, the ECU2 **combines the proven functionality of the ECU AnteRoom and Ceiling Cavity**. In addition to routine wall and ceiling based repair or remodeling, the ECU2 can be used for surge capacity (individual) and mass isolation.

Lightweight & Portable – Easy to deploy, move and take-down. One person can deploy the ECU2 in about 15 minutes. The units are both effective and have been designed for easy of use; access points and functionality are built to be convenient and match workflow needs.

Larger Anteroom & Airlock – Two ECU2s and a 5-foot connector cuff can be used in conjunction with the corridor flange accessory to create a larger anteroom/airlock for mass isolation. The corridor flange seals the entryway of a hallway or ward and the ECU2 operates as a large negatively pressured anteroom. This prevents direct air exchange between the isolated area and general population without any building modifications.



Specifications

Frame

- Lightweight, collapsible frame.
- 2-Piece top frame assembly with foam strip.
- Flat floor truss.
- Sturdy, non-skid polyurethane wheels.
- Collapsed dimensions: 12.0" x 12.0" x 66.0".
- Extended dimensions:
Footprint: 34.0" x 61.0"
Height: 7.0' x 10.5'
Weight: 45 lbs.

Standard

- Four Doors: (two narrow, two wide cargo):
Wide: 48", Narrow: 22".
- Four clear windows: 14.0" x 40.0".
- Two negative air ports in removal panel format.
- 12.5" Round port with drawstring and seal.
- 3.5" Round HEPA vacuum port with drawstring and seal.
- Double-reinforced floor.
- Clear pouch to display work/infection control permit.
- Weight: 20 lbs.
- Flange accessory:
20.0" long, flares 44.0" to 58.0".
- Connector Cuff: 12.0".

Item# **MNTECU2**

Item# **MNTECU2ENV** (Replacement Envelope)

Containment

EXPERIENCE THE DIFFERENCE

Containment

D-CON DISPOSABLE SHOWER ENCLOSURES

Grayling's D-Con is a low-cost, sturdy and disposable decontamination shower solution for abatement projects.

D-Con eliminates the hassle and cost of constructing a temporary decontamination facility on site. The D-Con sets up quickly and easily reducing labor cost. It is the first all poly constructed unit, which means it can withstand the daily rigors of abatement projects without losing any structural integrity. All D-Con units are made from two layers of 6-mil poly and have triple-flap ingress/egress doorways.

The D-Con is available in several different configurations. Support poles, drain water pick-ups and shower nozzle hardware are reusable and available separately.

Products

Item# **GRA1001005 D-Con 3** – The most popular 3 stage decon system in the industry. Enclosure dimensions: 37"x37"x77" 2-ply, 6-mil

Item# **GRA1002006 D-Con 2** – Designed for use with "pop-up" shower. Two enclosures (clean room/dirty room). Dimensions: 37"x37"x81" 2-ply, 6-mil

Item# **GRA1004001** – 77" Pole Set (12 per case)

Item# **GRA1004002** – 81" Pole Set (4 per case)

Item# **GRA1005001** – Shower head assembly



D-Con 3



Shower Head Assembly

WATER FILTRATION



PORTABLE SHOWER

The original collapsible telescoping decontamination shower is easily set up by two men in a matter of seconds.

Features

- Made in U.S.A.
- Lightweight aluminum construction.
- 100 Micron dram filter.
- Removable curtain.
- Two (2) handles for E-Z handling.
- Dimensions: Open - 31" x 30" x 83"; Closed - 31" x 31" x 48".
- Weight: 95 lbs.

Item# **AER9105**

TWO STAGE PUMP

Features

- Made in U.S.A.
- Enclosed aluminum container.
- Galvanized plumbing.
- 5 Micron and 50 Micron filtration.
- 12 Gallons per minute.
- 1/2 HP motor.
- Weight: 36 lbs.

Item# **AER9115**



Containment

ZIPWALL® BARRIER SYSTEM PRODUCTS are designed to work together. You can start with a small barrier system and add to it over time. We've packaged our products in easy-to-combine kits.

SLP 2 Pack

The SLP™ poles extend from 4'7" to 12 feet. The poles can be placed 8 to 10 feet apart. Two GripDisk™ slide stoppers come in every package.

- Package Includes
- 2 Spring loaded poles
 - 2 Grip disks
 - 2 Heads
 - 2 Plates
 - 2 Tethers

Item# **ZIPSLP2**



Plastic sheeting is not included.

4 Pack Plus

The SLP™ poles extend from 4'7" to 12 feet. Each foam rail is five feet long. Plastic sheeting is not included.

- Package Includes
- 4 SLP Poles
 - 2 Foam Rail cross bars
 - 4 Grip disks
 - 2 ZipWall standard zippers
 - 4 Heads
 - 4 Plates
 - 4 Tethers
 - 1 Carry bag

Item# **ZIP4PL**



KIT 20

The Kit 20 poles extend from 5'2" to 20 feet. The poles can be placed 8 to 10 feet apart. Two GripDisk™ slide stoppers come in every package.

- Package Includes
- 2 20-Foot spring loaded poles
 - 2 Grip disks
 - 2 Heads
 - 2 Plates
 - 2 Tethers

Item# **ZIPKT20**



Plastic sheeting is not included.

Heavy-Duty Zipper

Makes an easy doorway through plastic barriers.

- Has a greater adhesive area allowing for an aggressive tack.
- Each box comes with the ZipWall® zipper knife™ sheeting cutter.
- Has the smoothest glide available.
- Large sturdy easy-slide teeth.
- Is made with 2-sided pulls for easy entry/exit to or from the barrier.
- Works in below freezing temperatures.

This is the only zipper on the market that comes with the exclusive ZipWall® Zipper Knife™ sheeting cutter.

- Package Includes
- 2 Seven-foot zippers
 - Zipper knife
 - 2 Flap hooks

Item# **ZIPHDZ2**



Standard Zipper

- Has the smoothest glide available.
- Is engineered with large sturdy easy-slide teeth.
- Is made with 2-sided pulls for easy entry/exit to or from the barrier.
- Works best in temperatures >55°F.

The ZipWall® Zipper Knife™ sheeting cutter does not work with this zipper.

- Package Includes
- 2 Seven-foot self-adhesive zippers
 - 2 Flap Hooks to support openings
 - 2 Flap hooks

Item# **ZIP7**



Non Skid Plates (for SLP Pole Dust Barrier)

ZipWall® Non Skid Plates are the components that contact the ceiling. They are made of non-marking, non-skid material and can be cleaned easily. Package contains 2 plates.

Item# **ZIPNSP2**

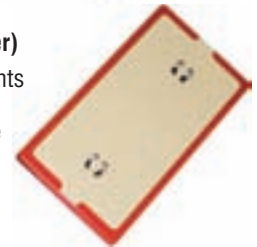

Foam Rail Cross Bars

Foam Rail™ crossbars were designed to work with all ZipWall® spring loaded poles (not included) and are sold 2 per pack. The included T-Clip is used to mount the poles at the center of the Foam Rail. The Foam Rail crossbars were not designed to hold up the plastic sheeting. They push the plastic or barrier material against the ceiling after the barrier has been built using ZipWall® poles placed 8 to 10 feet apart. They can also be used with Side Clamps (not included) to push the plastic against the wall. This makes an incredibly secure and tightly sealed barrier without tape.

- Package Includes
- 2 Five-foot Foam Rail cross bars
 - 2 T-clips

Item# **ZIPFR2**

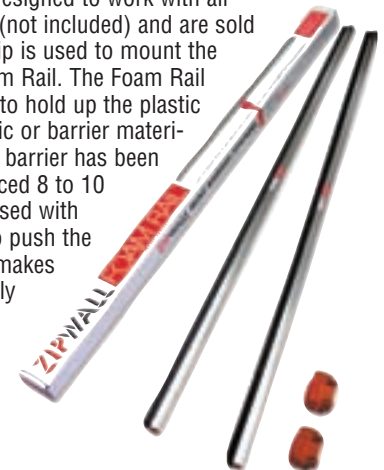

Containment

EXPERIENCE THE DIFFERENCE

Containment



COMMERCIAL ZIPDOOR™ KIT (Single Unit)



The Commercial ZipDoor™ kit is a great way to create a dust barrier when all you need to seal is the doorway. One person can install it in under a minute. You'll save hours on jobs with lots of doors like commercial office space, hotels, hospitals, and more. ZipWall zippers are glued-on for maximum sheer strength and durability. A stitched-on zipper can fail if pulled sharply or tugged because the stitching creates a perforation.

Features

- Pays for itself in time savings.
- For commercial doors up to 4' x 8', flame retardant.
- Made from 4 mil plastic sheeting.
- Two heavy-duty zippers pre-installed.
- Includes ZipWall double-sided tape.
- Can be repositioned easily for up to 1 hour.
- Ideal for RRP requirements.

Item# **ZIPZDC**

STANDARD ZIPDOOR™ KIT (Single Unit)



The Standard ZipDoor kit is a great way to create a dust barrier when all you need to seal is the doorway. One person can install it in under a minute. You'll save hours on jobs with lots of doors like commercial office space, hotels, hospitals, and more. Best of all, it's reusable. It's also great for residential jobs like kitchen and bath remodeling, or where renovation will disturb lead paint.

Features

- Pays for itself in time savings.
- Reuse it over again.
- For standard doors up to 3' x 7'.
- Made from 4 mil plastic sheeting
- Two heavy-duty zippers pre-installed.
- Includes ZipWall double-sided tape.
- Can be repositioned easily for up to 1 hour.
- Ideal for RRP requirements.

Item# **ZIPZDS**

SELF-ADHESIVE ZIPPERS



- **Creates instant access to tarps or plastic enclosures.**
- **Pressure sensitive adhesive backing.**
- **Can be opened from either side.**
- **Use 1 zipper for a flap or 2 for a wider opening.**

Create instant access to plastic enclosures and tarps with self adhesive zippers. These user friendly zippers can be applied in just minutes forming a secure zipper door. Simply peel off the backing paper and apply to the desired entry location. Then cut through the entire length of the zipper opening using a utility knife. It's that easy!

The red zipper is 1.5" wide by 7' long. For those who require a more heavy-duty zipper, we offer a 3" wide blue zipper. Both sizes have a very aggressive adhesive ensuring that dust or debris will not escape. (2/pk)

Item# **ZIP7HD-RD** (Red - 1.5" x 7')

Item# **ZIP7HD** (Blue - 3" x 7')

Coolers & Cups

GOTT WATER COOLERS



Rubbermaid® is the industry leader in water coolers.



10 Gal.

3 Gal.

Features

- Drip-resistant spigot.
- Leak-resistant lid.
- Insulated to keep water or beverage cold.

Item# **GOT1610** (10 gal.)

Item# **GOT1685** (5 gal.)

Item# **GOT1683** (3 gal.)

ROLLED RIM CONE CUPS

Rolled-rim paper cone cups help keep your water cooler more hygienic. Easy, one-at-a-time dispensing minimizes waste as the cone cups cannot be put down and left behind. Tight-seal seams ensure leak proof performance.

Item# **KCI4.5KR** (4.5 oz.)

Item# **IGL00025015** (8 oz.)



Drink Mix

G SERIES – 02 PERFORM

Hydration to help replace what you sweat out.



G2 Powder Sticks

- .52 Oz. Powder Sticks, 8 Pack.
- Low calorie / Replenish vital nutrients and energy.
- Natural and artificial flavor.
- Electrolytes + Carbs (5g)
- Optimized for use with 20 fl. oz. bottle of water.

Item# **GAT13167** (Grape)

Item# **GAT13168** (Fruit Punch)

Item# **GAT13160** (Glacier Freeze)



Gatorade Powder Sticks

- 1.34 Oz. Powder Sticks, 8 Pack.
- Natural and artificial flavor.
- Electrolytes + Carbs (13g)
- Replenish vital nutrients and energy.
- Optimized for use with 20 fl. oz. bottle of water.

Item# **GAT13165** (Orange)

Item# **GAT13166** (Fruit Punch)

Item# **GAT13163** (Lemon Lime)



Gatorade Instant Powder Mix

- 8.5 Oz. Pouch, 40/cs.
- 80 Calories per 12 fl. oz. serving.
- Add water, fuel your game.
- Makes 1 gallon.

Item# **GAT03956** (Lemon Lime)

Item# **GAT03957** (Orange)

Item# **GAT33665** (Riptide Rush)

Item# **GAT03808** (Fruit Punch)

Item# **GAT33302** (Fierce Grape)



Gatorade Instant Powder Mix

- 21 Oz. Pouch, 32/cs.
- 80 Calories per 12 fl. oz. serving.
- Add water, fuel your game.
- Makes 2.5 gallons.

Item# **GAT33691** (Fruit Punch)

Item# **GAT33677** (Glacier Freeze)

Item# **GAT03944** (Variety Pack)

Item# **GAT33673** (Riptide Rush)

Item# **GAT03970** (Orange)

Item# **GAT03969** (Lemon Lime)



Gatorade Instant Powder Mix

- 51 Oz. Pouch, 14/cs.
- 80 Calories per 12 fl. oz. serving.
- Add water, fuel your game.
- Makes 6 gallons.

Item# **GAT33690** (Fruit Punch)

Item# **GAT33676** (Glacier Freeze)

Item# **GAT03967** (Lemon Lime)

Item# **GAT03968** (Orange)

Item# **GAT33672** (Riptide Rush)



EXPERIENCE THE DIFFERENCE

Drink Mix

There's no better way to protect the body

against sweltering heat than with great-tasting Sqwincher. Scientifically proven to counter the effects of heat stress in high heat environments, Sqwincher has become standard safety equipment in most heat-related occupations—for pennies an ounce*. Even more importantly, consumers like the taste of Sqwincher! And because it's imperative for those in intense heat to consume adequate amounts of fluid, providing them with something they'll readily drink is the first step in ensuring their safety. With a great taste and an optimal formula, consumers drink Sqwincher more eagerly and on a more consistent basis. As a result, increasing their protection, productivity and performance while reducing their risk against lost time and medical expense.

*Figure may differ depending on individual usage and package size.

1 Gallon Powder Concentrate

9.53 Oz. pkg. makes 1 gal. – 80 Units/case.



Item#	Flavor
SQR016006-GR	Grape
SQR016004-OR	Orange
SQR016005-FP	Fruit Punch
SQR016008-LL	Lemon-Lime
SQR016007-AS	Assorted Pack*

*Lemon-Lime, Fruit Punch, Grape and Orange

2.5 Gallon Powder Concentrate

23.83 Oz. pkg. makes 2.5 gal. – 32 Units/case.



Item#	Flavor
SQR061047-CH	Cherry
SQR016046-GR	Grape
SQR016040-LA	Lemonade
SQR016041-OR	Orange
SQR016042-FP	Fruit Punch
SQR016043-LL	Lemon-Lime
SQR016049-TC	Tropical Cooler
SQR016045-TE	Tea
SQR016044-AS	Assorted Pack*
SQR016048-MB	Mixed Berry
SQR016050-CC	Cool Citrus

*Lemon-Lime, Fruit Punch, Grape and Orange

5 Gallon Powder Concentrate

47.66 Oz. pkg. makes 5 gal. – 16 Units/case.



Item#	Flavor
SQR016401-CH	Cherry
SQR016406-GR	Grape
SQR016403-LA	Lemonade
SQR016404-OR	Orange
SQR016405-FP	Fruit Punch
SQR016408-LL	Lemon-Lime
SQR016409-TC	Tropical Cooler
SQR016400-MB	Mixed Berry
SQR016402-CC	Cool Citrus

16.9 Oz. QwikServ™ Powder Concentrate

1.26 Oz. pkg. makes 16.9 oz.
96 Units/case.



Item#	Flavor
SQR060900-OR	Orange
SQR060901-FP	Fruit Punch
SQR060902-LL	Lemon-Lime
SQR060904-GR	Grape

Sqwincher Squeeze Freezer Pops

3 Oz. pkg. – 150 Units/case.



Item#	Flavor
SQR159200201	Assorted Pack*

*Lemon-Lime, Cherry, Grape, Mixed Berry and Orange

Fast Pack Liquid Concentrate

.6 Oz. pkg. makes 6 oz. – 200 Units/case.



Item#	Flavor
SQR015301-CH	Cheerry
SQR015302-GR	Grape
SQR015303-LA	Lemonade
SQR015304-OR	Orange
SQR015305-FP	Fruit Punch
SQR015308-LL	Lemon-Lime
SQR015309-TC	Tropical Cooler
SQR015306-TE	Tea
SQR015300-MB	Mixed Berry
SQR015310-CC	Cool Citrus

Sqwincher is designed to promote continuous consumption and prevent muscle cramps by providing an optimal formula with higher potassium and lower sodium compared to other sports drinks available today. And it tastes better.

Sqwincher vs. The Average Soft Drink

	Sqwincher	Avg. Soft Drink
Sodium	55 mg	16 mg
Potassium	45 mg	13 mg
Magnesium	.47 mg	not shown
Carbs	16 g	26.8 g
Calories	60	107



Electrical Specialty - Fish Tapes, Rods

MagnumPRO™ Oil-Tempered Spring Steel Fish Tapes – 1/8" Wide



FTS438-240

- Rugged case design improves drop impact capability.
- Oil-tempered spring steel for excellent fishing performance.
- Advanced comfort handle grip reduces fatigue.
- Superior rapid tape pay-out and rewind.
- Improved low profile tip for easy fishing through all sizes of conduit.
- Viewing Port gives visibility to remaining tape and ability to remove jobsite debris quickly.

CAT NO.	UPC NO.	DESCRIPTION
GREFTS438-125	12709	Steel Fish Tape - 125' × 1/8" (38.1 m × 3.2mm)
GREFTS438-240	12730	Steel Fish Tape - 240' × 1/8" (73.2 m × 3.2mm)

SPECIFICATIONS

Capacity	1/8" (3.2mm) tape width- 400 lbs. (1.7kN) maximum design strength	
Weight	FTS438-125 - 5.5 lbs. (2.5kg) FTS438-240 - 8.5 lbs. (3.9kg)	

MagnumPRO™ Nylon Fish Tapes



- Non-conductive, curl resistant nylon tape for fast, clean fishing.
- Good for fishing in conduit with wire or cable present.
- Rugged case design improves drop impact capability.
- Advanced comfort handle grip reduces fatigue.
- Nylon fish tape is intended for fishing only. Rope or line is recommended for pulling.

CAT NO.	UPC NO.	DESCRIPTION
GREFTN536-100	12716	Nylon Fish Tape 100' × 3/16" (30.5 m × 4.8mm)

SPECIFICATIONS

Capacity	3/16" (4.8mm) diameter – 250 lbs. (1.1kN) max. design strength	
Weight	FTN536-100 – 3.6 lbs. (1.6kg)	

Flex-O-Twist® Flexible Fish Tape Leader



- Helps guide 1/8" steel tapes through sharp bends.
- Thread on the end of the fish tape in place of the swivel ball head.

CAT NO.	UPC NO.	DESCRIPTION
GRE439-1	30859	12" (305mm) Flexible Fish Tape Leader

SPECIFICATIONS

Weight	1.3 lbs. (0.6kg)	
---------------	------------------	--

Glo Stix®



- Luminescent fiberglass rods glow in the dark for fishing in dark spaces.
- More flexible for fishing in walls through outlet box holes.
- Sturdy, steel-threaded connectors are interchangeable with Greenlee 1/4" (6.4mm) Fish Stix.
- Clear, non-metallic storage tube keeps Glo Stix charged and ready to use.
- 200 lbs. (0.9kN) maximum pulling strength.
- Optional Whisk Nose Tip is available for fishing over obstacles, and can be used to guide extended Glo Stix sideways above ceilings by rotating.

CAT NO.	UPC NO.	DESCRIPTION
GRE540-15	11422	3/16" Glo Stix 15' (4.7m x 4.6m) Kit with bullet nose and "J" hook threaded tips, packaged in clear plastic tube
GRE11426	11426	Whisk Nose Tip

SPECIFICATIONS

Length	15' (4.6m) – (3) 5' (1.5m) sections	
Diameter	3/16" (4.7mm)	
Material	Luminescent fiberglass rod	
Min. Bend Radius	4-1/4" (108mm)	



EXPERIENCE THE DIFFERENCE

Electrical Specialty - Conduit Fishing

VALVE ASSEMBLY AND SEAL-OFF FOR CONDUIT FISHING SYSTEMS



1105A



1215



1216



1206

Part #	Description	Weight
1105A	12' valve assembly with UG12 hose only	3.6 lbs.
1215	Seal-off for 1/2" - 1" conduit with 2' hose	.4 lb.
1216	Seal-off for 1 1/4" - 2 1/2" conduit with 2' hose	.8 lb.
1206	Seal-off for 1 1/2" - 6" conduit	5.2 lbs.

AIR COMPRESSOR SEAL-OFF

Use with most commercial air compressors to blow pull line into conduit or duct. For use with 2" to 6" conduit sizes.

- The Dial-A-Line™ feature is incorporated into the compressor fitting.
- Maximum 200 cfm rating.
- Shut-off valve.

Part #	Description	Weight
CB21V	Air Compressor Seal-off	6 lbs.

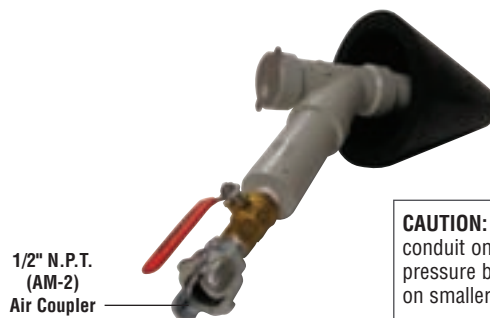

1/2" N.P.T. (AM-2) Air Coupler

CAUTION: Use in 2 1/2" - 6" conduit only. To avoid rapid pressure build-up, do not use on smaller sizes of conduit.

MISSILE LINE CARRIERS

For 2" to 6" conduit.

- Fast blowing and vacuuming of 2" to 6" diameter conduit by low-friction plastic carriers.
- Easily removed from conduit if stuck or jammed.

Part #	Qty.	Description	Weight
M2000	1/bg.	Missile Line Carrier for 2" conduit (w/rope eye)	.1 lb.
M4000	1/bg.	Missile Line Carrier for 4" conduit (w/rope eye)	.3 lb.
M6000	1/bg.	Missile Line Carrier for 6" conduit (w/rope eye)	.5 lb.



M2000

M4000

M6000

FISH TAPE LEADER

Multi-Flex™ is a flexible, non-kink, round metallic leader – perfect for flat steel tapes.

- Double-sheathed to prevent unraveling. Brass plated for corrosion resistance.
- Spring coil easily curves around bends, yet is rigid enough to fish smoothly through conduit with existing wire.
- High strength – tested at 400 lb. tensile strength.
- Attaches directly to 1/8" tapes, adapts to fit 1/4" tapes.



Part #	Description	Weight
FTL-5	Fish Tape Leader, Multi-Flex™	.5 lb.

Electrical Specialty - Pulling Tapes and Ropes

FIBER OPTIC CABLE PULLING TAPE

HERCULINE® is the premium choice for underground measuring and pulling of fiber optic and lightweight cables. Specifically designed for the telecommunications, power utility and CATV industries, **HERCULINE** can be easily blown through innerduct to provide smooth, safe pulls. Durable footmarkings allow for accurate measurement while flat construction and specially formulated lubricants work to minimize friction and duct cutting.

HERCULINE®



POLYESTER HERCULINE®						
Item#	Tensile	Width	Length	Construction	Footmarkings	
HRCP400W	400 lbf	1/4"	3000'	Stranded	Yes	
HRC1250W-10000	1250 lbf	1/2"	10000'	Woven	Yes	
HRC1250W-5K	1250 lbf	1/2"	5000'	Woven	Yes	
HRC1250W	1250 lbf	1/2"	3000'	Woven	Yes	
HRC1800W	1800 lbf	5/8"	3000'	Woven	Yes	
HRC2500W-5K	2500 lbf	3/4"	5000'	Woven	Yes	
HRC2500W	2500 lbf	3/4"	3000'	Woven	Yes	
DETECTABLE POLYESTER HERCULINE®						
Item#	Tensile	Width	Length	Construction	Footmarkings	
HRC1250W-DET	1250 lbf	1/2"	3000'	Woven	Yes	
HRC1800W-T	1800 lbf	5/8"	3000'	Woven	Yes	
HRC2500W-DET	2500 lbf	3/4"	3000'	Woven	Yes	

WHITE POLYESTER CORD STRAPPING

PACSTRAP® Polyester Cord Strapping outperforms steel and polypropylene in many industrial and agricultural strapping and tying applications. Manufactured from high tensile polyester yarns, **PACSTRAP** can absorb sudden impacts that might break steel strapping. But unlike polypropylene, which has much higher elongation, **PACSTRAP** can recover up to 99% of its original size. This combination of elongation and memory allows **PACSTRAP** to absorb load shifting and maintain tension over time.

- **PACSTRAP** is unaffected by moisture, so it will not rust and discolor your load. It will not rot, mildew or become soggy, nor will it lose strength in extreme temperatures.
- **PACSTRAP** is resistant to the UV light of the sun and many chemicals and solvents.
- **PACSTRAP** is soft and pliable, so it is safe and easy to work with. It will not recoil when cut, and it has no sharp corners or edges. It can be reused or easily disposed.
- **PACSTRAP** can be tied by hand in the field or secured with a buckle or a seal using a hand-tensioner.
- **PACSTRAP** Polyester Cord Strapping can be used to Palletize, Unitize, Tie, Bale, Bundle, Secure and Support items in Agriculture, Lumber, Marine and General Industry.

PACSTRAP®



REGULAR DUTY PACSTRAP®				
Item#	Tensile	Width	Length	Construction
HRCP50R	850 lbf	5/8"	3000'	Stranded

EXPERIENCE THE DIFFERENCE

Electrical Specialty - Cable Pulling

Mantis™ Mobile Cable Pulling Package w/Model 88 Cable Puller

- Excellent Mobility.
- Easy set-up.
- Transport without complete disassembly.
- Pulls up to 20' extra cable.
- 8,000 Lb. capacity.
- Fits through 32" doorway.
- Will fit Greenlee® Model 6001 Super Tugger® and 640 Tugger®.



Weight: 992 lbs.

- Set includes:**
 Cable Puller w/Chains
 Elbow Unit
 Nose Unit
 Floor Mount
 T-Stand
 Mobile Carriage
 Puller Mount
 (2) 3' Boom Tubes
 (2) 4' Boom Tubes
 3" Slip-In Coupling

- 3-1/2" Slip-In Coupling
 4" Slip-In Coupling
 Coupling Adapter
 3" Screw-On Coupling
 3-1/2" Screw-On Coupling
 4" Screw-On Coupling
 Storage Box
 Caster Set

Item# **CUR8890AS**

**Greenlee®, Super Tugger® and Tugger® are registered trademarks of Greenlee/Textron.*

Ratchet Type Reel Stand

- Heavy-duty stands for large reel projects.
- All steel construction.
- Ratchet mechanism to raise and lower the height.
- Wide base for added stability.
- Roller heads have self-lubricating bearings.

Capacity: 3,750 lbs. each
 Height: 28" min. to 45" max.
 Reel Dia.: 58" min. to 90" max.
 Weight: 99 lbs.

Item# **CUR680**



Dolly Cart

- Heavy-duty dolly type cart can be used vertically or horizontally.
- Rods to hold wire reels have spring clips on each end for easy loading/unloading.
- Large 8" wheels for easy mobility.
- Wire guide on handle for horizontal dispensing.
- Will fit through 28" door.

Capacity: (6) 2,500' spools up to 16" diameter or (15) 500' spools

Weight: 62 lbs.

Item# **CUR501**



Turtle Cart

- Heavy-duty frame - solid through-bar construction.
- Wire guide permanently mounted to front of cart.
- Spindle designed to reduce backlash.
- Will fit thru 30" door.
- Large wheels for easy mobility.
 - front swivel/brake caster.
 - semi pneumatic rear wheels.

Capacity: (6) 2,500' spools up to 18" diameter

Weight: 86 lbs.

Item# **CUR502**



Armored Cable Dispenser

- Sturdy steel construction for rugged use.
- Includes cable guide to prevent tangles.
- Adjustable spring to prevent overfeeding.

Dispensing Capacity: (1) coil, 250' 14/2, 14/3, 12/2, 12/3

Armored cable or unboxed Romex

Weight: 25 lbs.

Item# **CUR509**



Conduit Rack

- For organizing conduit or pipe.
- 7 spaces for sorting.
- Arms fold down to save space.
- Provided with large 6" casters; 2 swivel and 2 fixed.

Capacity: 1,000 lbs.

Weight: 111 lbs.

Item# **CUR505**





Electrical Specialty - Cable Pulling

SUPER-SLICK™ CABLE-PULLING LUBRICANT

Exclusive GB® Micro Bead Formula rolls cable through the longest pulls.

- Lowest pulling tension. This GB® lubricant innovation combines a lubricating agent with microbeads that act as miniature ball bearings to raise the cable off the conduit surface. Cable literally rolls through the run, reducing friction by an additional 30% compared to regular lubricants.
- Adheres throughout long pulls. Creates a slick film that will not rub off or dry out on long pulls or re-pulls.
- Requires up to 45% less lubricant per foot than regular lubricants, actually reducing cable-pulling costs.
- Stable under temperature extremes of 28°F to 200°F and withstands repeated freeze-thaw cycles.
- Harmless to skin and safe for the environment. Non-toxic, nonflammable and non-corrosive to all conduit types. Easily cleans up with water and will not stain clothing.
- Universally compatible with all cable types and jacket materials, including low-density and linear low density polyethylene, polyurethane and semi-conducting jackets.



Part #	Container Size	Weight
79-401	1 qt. Squeeze Bottle	2.5 lbs.
79-402	1 gal. Jug	8.75 lbs.
79-403	5 gal. Pail	42 lbs.

Super-Slick™ Specifications

Base	Water	Staining Properties	Non-staining
Color	White	Removal	Water Rinse
Viscosity	2100 cps@ 50 rpm	Abrasion Protection	Excellent
pH	6.0 - 8.0	Cling Ability	Excellent
Freezing Point	30.2°F	Hardening Characteristic	Non-Hardening
Freeze-Thaw Stability	Excellent	Condition on Drying	Slick Film
Lubricity	Excellent	Flash Point	Non-Combustible
Shelf Life	Indefinite		

Electrical Specialty - Hand Tools

ARMOREDGE® WIRE STRIPPER

Strips and cuts solid and stranded wire.

- Stainless steel body for maximum corrosion resistance.
- Ergonomic, cushioned handles for ultimate comfort and control.
- Double bevel cutting blades for superior nick resistance.
- Dual gripping positions for traditional or forward hand positions.
- Easy-to-read laser-etched markings.
- Cuts and rethreads bolt sizes 6-32, 8-32 and 10-32.
- Wire looping holes form wire to fit on screw terminals.
- Plier nose for gripping and pulling.
- Limited Lifetime Warranty.



Part #	Description	Handle	Wire Gauge	Length
GES-55	ArmorEDGE™ Wire Stripper	Curved	#10 - #18 AWG	6½"

HIGH-LEVERAGE CUTTERS

Cuts soft copper and aluminum cable up to 1000 MCM.

- Heat-treated alloy steel jaws make fast, sharp cuts.
- Lightweight fiberglass handles on GC-500 and GC-1000 feature comfortable rubber grips.



Part #	Description	Cut Size	Length	Replacement Jaw#
GC-500	Cable cutter	500 MCM max.	24"	GCRJ-500
GC-1000	Cable cutter	1000 MCM max.	33"	GCRJ-1000

EXPERIENCE THE DIFFERENCE

Electrical Specialty - Conduit Benders

CYCLONE® – Electric-Powered Conduit Bender



One shoe bends 1/2" - 2" conduit with no loose parts:

- Rigid
- Rigid aluminum
- EMT
- IMC
- PVC-coated rigid (1/2" to 1-1/2")
- Ability to make repeatable bends at the same degree.
- Horizontal and vertical positions allow the unit to create accurate offset bends.
- Four-wheels increases mobility.
- Low-volt (95), high-volt (132) automatic shut-off helps protect electrical components from voltage fluctuations.
- Resetting circuit breaker eliminates down time changing fuses.
- On/Off switch allows user to shut machine down for extended periods of time.
- Hook attachment on pendant control frees hands while working with conduit.
- Minimal training time.
- Weather-resistant cover included.
- 10/115 V AC, 15 AMP 1 HP DC Motor.
- Dimensions: 47" x 33" x 43".
- Weight 408 lbs.



FEATURES:

Strong Legs

Increased durability (10x life test).

Large Tires/Wheels

Increased mobility.

Stronger Upright Handle

Ease of use.

Fork Lift Tubes

Allows lifting and transport capability – built into base.

Lift Hook

Security (jobsite) tethering.

Storage Area

Storage for tools, etc., while in use.

Part #	Description	Weight
B2000	Cyclone™ electric-powered production bender, 115 V / 15 A	408 lbs.



Can be performed in the horizontal or vertical position.

CENTERLINE RADIUS CHART

Conduit Size	IMC	PVC-Coated Rigid	EMT	Rigid
1/2"	4-3/8"	5-3/8"	4-1/4"	4-3/8"
3/4"	5-5/16"	6-1/2"	5-3/8"	5-5/16"
1"	6-7/32"	7-27/32"	6-1/2"	6-7/32"
1-1/4"	7-23/32"	8-3/8"	7-27/32"	7-23/32"
1-1/2"	8-7/32"	N/A	8-3/8"	8-15/64"
2"	9-15/32"	N/A	9-21/32"	9-29/64"



Easy dial settings-makes training time virtually non-existent.

Electrical Specialty - Conduit Benders

Electric Benders

To bend 1/2" thru 2" EMT and Rigid conduit

- Powerful motor will make 180° ends on up to 2" rigid conduit.
- Rugged and dependable electrical system.
- Easy to maintain.
- Shoes and roller support assemblies will fit Greenlee® 555° electric bender.*
- 2-year warranty.



Item#	Description	Weight
CUR77RIG	Electric Bender with No. 700R Rigid shoes and accessories	365 lbs.
CUR77EMT	Electric Bender with No. 700E EMT shoes and accessories	430 lbs.

Specifications

Power Source	Capacity	Dimensions
120 vac; 20 amp GFCI protected receptacle required.	77RIG 1/2" to 2" Rigid conduit and 1/2" to 1-1/4" IMC conduit	Height: 42" Width: 29.5" Depth: 24.5"
	77EMT 1/2 to 2" EMT conduit	

Bend Radius Chart

Size	EMT	Rigid
1/2"	4-1/4	4-3/8
3/4"	5-3/8	4-1/2
1"	6-3/4	5-3/4
1-1/4"	8-3/4	7-1/4
1-1/2"	8-9/32	8-1/4
2"	9-3/16	9-1/2

*Greenlee® and 555° are registered trademarks of Greenlee/Textron.



PVC Heater for 1/2"-2" PVC Conduit

- Full length door allows easy loading and removal of PVC conduit.
- Manual operation.
- 115 vac-1700 watts – 15 amps.
- Lighted ON/OFF switch.
- Highly reflective interior for even heating.
- Includes convenient carrying handle.



Width: 6-3/4"
Height: 9-1/4"
Length: 26-3/8"
Weight: 22 lbs.

Item# **CUR450**



PVC Heater for 1/2" - 4" PVC Conduit



Width: 9"
Height: 12-3/4"
Length: 56-7/8"
Weight: 52 lbs.

- Durable wheels for maximum mobility.
- Full length door allows easy loading and removal of PVC conduit.
- Manual operation.
- 120 vac – 2300 watts – 20 amps.
- Lighted ON/OFF switch.
- Highly reflective interior for even heating.

Item# **CUR451**

PVC Heater for 1/2" - 6" PVC Conduit Auto Rotate

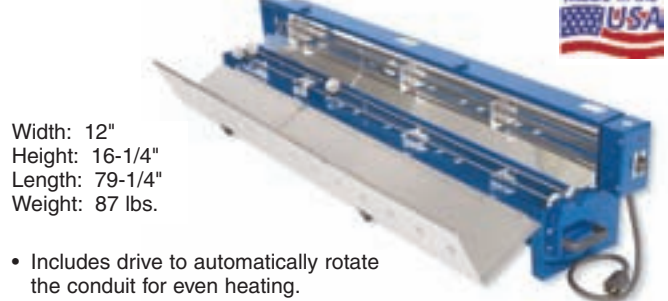

Width: 12"
Height: 16-1/4"
Length: 79-1/4"
Weight: 87 lbs.

- Includes drive to automatically rotate the conduit for even heating.
- Durable wheels for maximum mobility.
- Double doors allow heating of shorter lengths of PVC conduit with one door open.
- 230 vac - 6400 watts - 28 amps.
- Power indicator light.
- Stainless steel doors.

Item# **CUR453**

Electrical Specialty - Knockout Punches



Ratchet Knockout Set

- Features Piece Maker™ punches.
- 1" Hex ratchet wrench fits both 3/8" and 3/4" draw bolts.
- Heavy-duty plastic carrying case.
- Designed to punch a maximum of 10 gauge (.134") mild steel.
- Compare with Greenlee® Slug-Buster® Model 7238SB.*

Hydraulic Knockout Set

- Designed to split the slug in two pieces for easy removal.
- Requires less force than conventional punches.
- Fast set-up.
- High-strength steel punches and dies for long life.
- Reduces punch time versus manual or ratchet methods.
- Unique hand pump design with heavy-duty ram.
- Designed to punch a maximum of 10 gauge (.134") mild steel.
- Compare with Greenlee® Slug-Buster® Model 7306SB.*



Weight: 9 lbs.



Piece Maker™ Punches are designed to split the slug in two pieces for easy removal from die after punch completion.



Weight: 29 lbs.

Set includes:

- 1" Ratchet Wrench
- Draw Bolt – 3/8" x 1-5/8"
- Draw Bolt – 3/4" x 2-15/16"
- 1/2" Piece Maker™ Punch
- 1/2" Die
- 3/4" Piece Maker™ Punch
- 3/4" Die
- 1" Piece Maker™ Punch
- 1" Die
- 1-1/4" Piece Maker™ Punch
- 1-1/4" Die
- 1-1/2" Piece Maker™ Punch
- 1-1/2" Die
- 2" Piece Maker™ Punch
- 2" Die
- Plastic Case

Item# **CUR157PM**



Set includes:

- Ram
- 3/4" Draw Stud
- (1) 3/8" Draw Studs
- Short Spacer - S
- Medium Spacer - M
- Large Spacer - L
- Hydraulic Hand Pump
- 1/4" x 3' Hydraulic Hose
- Plastic Carrying Case
- 1/2" Piece Maker™ Punch
- 1/2" Die
- 3/4" Piece Maker™ Punch
- 3/4" Die
- 1" Piece Maker™ Punch
- 1" Die
- 1-1/4" Piece Maker™ Punch
- 1-1/4" Die
- 1-1/2" Piece Maker™ Punch
- 1-1/2" Die
- 2" Piece Maker™ Punch
- 2" Die

Item# **CUR152PM**



*Greenlee® and Slug-Buster® are registered trademarks of Greenlee/Textron.



Electrical Specialty - Knockout Punches

Slug-Buster SC® (Self-Centering) Knockouts



- Save time and ensure accuracy! Self-centering punch aligns itself on pilot hole.
- No need to draw crosshairs or line up die alignment marks.
- Unique punch also splits slugs for easier slug removal.
- US Patent No. 6,973,729.

**Also Available for
Stainless Steel**

SLUG-BUSTER®



PUNCH UNIT CAT NO.	UPC	CONDUIT & PIPE SIZE	HOLE SIZES		WEIGHT OF PUNCH UNIT		PUNCH ONLY		DIE ONLY		STUD ONLY	
			INCH	MM	LBS.	G	CAT NO.	UPC	CAT NO.	UPC	CAT NO.	UPC
GRE77U-1/2*	10801	1/2"	.885	22.2	0.3	137	77P-1/2	11361	14722	14722	00042	00042
							77P-1/2P*	11261	14722P*	01992	00042	00042
GRE77U-3/4*	10802	3/4"	1.115	28.3	0.8	363	77P-3/4	11362	124AV	06972	294AVBB	04040
							77-3/4P*	11262	124AVP*	01993	294AVBBP*	01987
GRE10807*	10807	-	1.21	30.5	0.9	408	11357	11357	3627B	3627B	294AVBB	04040
GRE77U-1*	10803	1"	1.362	34.6	1.0	454	77P-1	11363	126AV	04011	2494ABB	04040
							77P-1P*	11263	126AVP*	01994	294AVBBP	01987
GRE77U-1-1/4*	10804	1-1/4"	1.701	43.2	1.3	590	77P-1-1/4	11364	128AV	04013	294AVBB	04040
							77P-1-1/4P*	11264	128AVP*	01995	294AVBBP*	01987
GRE77U-1-1/2*	10805	1-1/2"	1.951	49.6	2.1	953	77P-1-1/2	11365	440AV	04061	304AVBB	04042
							77P-1-1/2P*	11265	440AVP*	01996	304AVBBP*	01988
GRE77U-2*	10806	2"	2.416	61.4	2.3	1043	77P-2	11366	442AV	04063	304AVBB	04042
							77P-2P*	11266	442AVP*	01997	304AVBBP*	01988
GRE10800	10800	1/2"-2" Kit	-	-	-	-	-	-	-	-	-	-

*POP Packaged

10800 Slug-Buster SC Knockout Kit Includes:

CAT NO.	UPC NO.	DESCRIPTION	CONDUIT SIZE	HOLE SIZE
GRE77P-1/2	11361	1/2" Punch Buster, SC	1/2"	.885
GRE14722	14722	1/2" Die Rd.	1/2"	.885
GRE77P-3/4	11362	3/4" Punch Buster, SC	3/4"	1.115
GRE124AV	06972	3/4" Die Rd.	3/4"	1.115
GRE77P-1	11363	1" Punch Buster, SC	1"	1.362
GRE126AV	04011	1" Die Rd.	1"	1.362
GRE77P-1-1/4	11364	1-1/4" Punch Buster, SC	1-1/4"	1.701
GRE128AV	04013	1-1/4" Die Rd.	1-1/4"	1.701
GRE77P-1-1/2	11365	1-1/2" Punch Buster, SC	1-1/2"	1.951
GRE440AV	04061	1-1/2" Die Rd.	1-1/2"	1.951
GRE77P-2	11366	2" Punch Buster, SC	2"	2.416
GRE442AV	04063	2" Die Rd.	2"	2.416

EXPERIENCE THE DIFFERENCE

Electrical Specialty - Knockout Punches

Slug-Buster® Manual Knockout Kits



- Assortment of commonly used Slug-Buster knockout punches, packaged to meet the contractor's needs.
- High-impact, rugged plastic carrying case.

CAT NO.	UPC NO.	DESCRIPTION	CAPACITY			
			MILD STEEL		WEIGHT	
			GA	mm	LBS.	kg
GRE7235BB	32013	1/2" - 1-1/4" Conduit Size Manual Slug-Buster Knockout Punch Kit	10	3.5	2.7	1.2

7235BB/32013 SLUG-BUSTER KNOCKOUT PUNCH KIT INCLUDES

CAT NO.	UPC NO.	DESCRIPTION	HOLE SIZE ACTUAL		
			Ø INCH	Ø mm	
GRE721-1/2	31756	1/2" Conduit Size Punch	7/8	.885	22.5
GRE14722	14722	1/2" Conduit Size Die	7/8	.885	22.5
GRE00042	00042	Draw Stud – 3/8" x 1-5/8"			
GRE721-3/4	31757	3/4" Conduit Size Punch	—	1.115	28.3
GRE124AV	06972	3/4" Conduit Size Die	—	1.115	28.3
GRE721-1	31758	1" Conduit Size Punch	—	1.362	34.6
GRE126AV	04011	1" Conduit Size Die	—	1.362	34.6
GRE721-1-1/4	31759	1-1/4" Conduit Size Punch	—	1.701	43.2
GRE128AV	04013	1-1/4" Conduit Size Die	—	1.701	43.2
GRE249AVBB	04040	Draw Stud – 3/4" x 2-1/8"			
GRE31880	31880	Plastic Case			

Slug-Buster® Knockout Kit with Ratchet Wrench



- 1" Hex Ratchet Wrench allows use with both 3/8" (9.5mm) and 3/4" (19.1mm) draw studs.
- High-impact, rugged plastic carrying case.

CAT NO.	UPC NO.	DESCRIPTION	CAPACITY			
			MILD STEEL		WEIGHT	
			GA	mm	LBS.	kg
GRE7238SB	34757	1/2" - 2" Conduit Size Slug-Buster Knockout Punch Kit	10	3.5	10	4.54

7238SB/34757 SLUG-BUSTER KNOCKOUT PUNCH KIT INCLUDES

CAT NO.	UPC NO.	DESCRIPTION	HOLE SIZE ACTUAL		
			Ø INCH	Ø mm	
GRE34941	34941	Ratchet wrench – 1" Hex			
GRE721-1/2	31756	1/2" Conduit Size Punch	7/8	.885	22.5
GRE14722	14722	1/2" Conduit Size Die	7/8	.885	22.5
GRE721-3/4	31757	3/4" Conduit Size Punch	—	1.115	28.3
GRE124AV	06972	3/4" Conduit Size Die	—	1.115	28.3
GRE721-1	31758	1" Conduit Size Punch	—	1.362	34.6
GRE126AV	04011	1" Conduit Size Die	—	1.362	34.6
GRE721-1-1/4	31759	1-1/4" Conduit Size Punch	—	1.701	43.2
GRE128AV	04013	1-1/4" Conduit Size Die	—	1.701	43.2
GRE721-1-1/2	31760	1-1/2" Conduit Size Punch	—	1.951	49.6
GRE440AV	04061	1-1/2" Conduit Size Die	—	1.951	49.6
GRE721-2	31761	2" Conduit Size Punch	2-3/8	2.416	61.5
GRE442AV	04063	2" Conduit Size Die	2-3/8	2.416	61.5
GRE00042	00042	Ball Bearing Draw Stud with 1" Hex Head – 3/8" x 1-5/8"			
GRE304AVBB	04042	Ball Bearing Draw Stud – 3/4" x 2-15/16"			
GRE34758	34758	Plastic Case			



Electrical Specialty - Hydraulic Punches

Quick Draw® Hydraulic Punch Driver Kits

7706SB
Flex Driver Kit



- Compact, lightweight design for portability and fast, easy one-person operation.
- Develops 8 tons of hydraulic force for easy punching, even in 10 gauge stainless steel, depending on individual punch capacities.
- Quick Draw is perfect for fast, straight-on front panel punching.
- Quick Draw 90's right angle driver head rotates over 180 degrees for maximum flexibility in tight working areas.
- Quick Draw Flex allows unlimited driver orientation to simplify access to work area.
- Can be used with non-round punches within the capacity of the tool (adapter may be required).
- U.S. Patent #6,772,521.

7806SB
Quick Draw Kit



7906SB
Quick Draw 90 Kit



CAT NO.	UPC NO.	DESCRIPTION	WEIGHT	
			LBS.	kg
GRE7706SB	10476	Standard – Quick Draw Flex Driver, 1/2" through 2" Slug-Buster® Conduit Size Punches and Dies, 2 Draw Studs, 1 Adapter, 1 Spacer and Case	17.3	7.9
GRE7806SB	34293	Standard – Quick Draw Driver, 1/2" through 2" Slug-Buster Conduit Size Punches and Dies 2 Draw Studs, 1 Adapter, 1 Spacer and Case	14	6.4
GRE7906SB	34300	Quick Draw 90 Driver, 1/2" through 2" Slug-Buster Conduit Size Punches and Dies, Draw Studs, 1 Adapter, 1 Spacer and Case	14	6.4

STEEL CAPACITIES FOR CONDUIT SIZES

REQUIRED DRAW STUD AND ACCESSORIES	STANDARD & SLUG-BUSTER® PUNCHES						SLUG-SPLITTER®				
	1/2"	3/4"	1-7/32" OILTIGHT	1"	1-1/4"	1-1/2"	2"	1/2"	3/4"	1-7/32" OILTIGHT	1-1/4"
3/8" Draw Stud											
Spacer and 7/16" Draw Stud											
Spacer and 3/4" Draw Stud											
3/4" Draw Stud											

10 GA. MILD STEEL

10 GA. STAINLESS STEEL

Slug Buster® Ram and Hand Pump Hydraulic Driver Kits



7310SB

- Fast, easy and simple to operate.
- Compact design for field use on construction sites and maintenance jobs.
- Punches 10 times faster than wrench method.
- Will also drive 751 Cable Cutter head.
- Can be used with most standard round Slug-Buster and Slug-Splitter® punches (not 1/2", 9/16", 5/8").
- Can be used with non-round punches (adapter may be required).
- 3-Foot hose.
- Powerful 11-ton hydraulic ram.

CAT NO.	UPC NO.	DESCRIPTION	WEIGHT	
			LBS.	kg
GRE7306SB	34360	Driver, Hand Pump, Slug-Buster Punches, Dies and Draw Studs for 1/2" - 2" Conduit, Adapter, Spacers, Kwik Stepper® Step Bit and Plastic Case	24	10.9
GRE7310SB	34361	Driver, Hand Pump, Slug-Buster Punches, Dies and Draw Studs for 1/2" - 2" and 2-1/2" - 4" Standard Conduit Size Punches, Dies and Draw Studs, Adapter, Spacers, Kwik Stepper Step Bit and Steel Case	54	24.5

STEEL CAPACITIES FOR CONDUIT SIZES

REQUIRED DRAW STUD AND ACCESSORIES	STAND. & SLUG-BUSTER® PUNCHES						STANDARD				SLUG-SPLITTER®					
	1/2"	3/4"	1"	1-1/4"	1-1/2"	2"	2-1/2"	3"	3-1/2"	4"	1/2"	3/4"	1"	1-1/4"	1-1/2"	2"
3/4" Stud (03294), 3/8" Stud (30043) and Spacers																
3/4" Stud (03294), Long Spacer																
3/4" Stud (03294), Short Spacer																
3/4" Stud (03294)																
3/4" Stud (03294), and Sleeve (03170)																
7/16" Stud (29451)																
3/4" Stud (29452)																

10 GA. MILD STEEL

10 GA. STAINLESS STEEL

EXPERIENCE THE DIFFERENCE

Electrical Specialty - Testing Instruments

RECEPTACLE TESTER & CIRCUIT ANALYZER

Tests standard receptacles to ensure proper wiring.

- Neon indicators give positive indication of circuit status.
- Compact unit simply plugs into any standard 3-wire/grounded receptacle (110 - 125 V AC circuits).
- Tests for six circuit conditions: open ground, open neutral, open hot, hot/ground reverse, hot/neutral reverse, and correct wiring.
- Succession of yellow and red lights provides indication of circuit status or specifies wiring errors.
- Easy-to-read three views – top, side and bottom.

Part #	Description
GBEGRT-3500	Receptacle Tester & Circuit Analyzer



TESTS

- ✓ Standard outlets
- ✓ Extension cords

GROUND FAULT RECEPTACLE TESTER & CIRCUIT ANALYZER

Tests ground fault receptacles by overloading circuit and tripping GFCI.

- Easy to use. Simply plug tester into any circuit protected by a ground fault receptacle (110 - 125 V AC) and press black button to overload circuit.
- Tests for seven conditions: ground fault interruption, open ground, open neutral, open hot, hot/ground reverse, hot/neutral reverse, and correct wiring.
- Succession of yellow and red lights provides indication of circuit status or specifies wiring errors.
- Tester trips GFCI between 6 - 9 mA.

Part #	Description
GBEGFI-3501	Ground Fault Receptacle Tester & Circuit Analyzer



TESTS

- ✓ Standard outlets
- ✓ GFCI outlets
- ✓ Extension cords

Electrical Specialty - Wire Tracing, Testing

Classic Tone and Probe Kit



- Permits technicians to identify the conductor within a bundle, at a crossconnect point or at the remote end.
- Can be used on twisted pair wiring (telecom, datacom, etc.), single conductors, coaxial cables, de-energized AC wiring and most other wiring.
- Kit includes the 77HP High Power Tone Generator and the 200EP Inductive Amplifier in a rugged, woven nylon carrying case. (700C)

CAT NO.	UPC NO.	DESCRIPTION
GRE701K-G	49990	Classic Tone and Probe Kit, Standard

CATV Cable Tone Test Kit



- Designed specifically for the CATV industry, this kit allows you to tone through splitters, directional couplers and traps.
- Simple to use, the 402K provides accurate results and will eliminate long delays trying to figure out non-tagged or mis-tagged cable drops.
- Kit includes one transmitter, one receiver, one male F-to-F connector adapter cable, one male F-to-alligator clip adapter cable and a carrying case (700C).
- Transmitter and receiver are equipped with female F-connectors.
- Three methods of signal reception: electrostatic pickup for non-terminated cables, electromagnetic pickup for terminated or shorted cables and direct connection when identifying in the presence of passive devices.
- In continuity mode, provides both audible tone and LED display.
- Identifies the presence of AC or DC voltage on the cable under test.
- Four selectable tone outputs for multiple line identification.

CAT NO.	UPC NO.	DESCRIPTION
GRE402K	08677	CATV Cable Tone Test Set
GRE402T	60376	Transmitter
GRE402R	60377	Receiver
GRECS9	60374	Male to male F-connector adapter cable
GRECS19	60378	F-connector to alligator clip





Electrical Specialty - Cable Cutters

ROTO-SPLIT® CABLE CUTTERS

Save Time — Cut Labor — Enhance Safety!

A few turns of the crank of this compact tool produces a clean slit through armored casing. **This takes only a few seconds, simply untwist to strip!** Cutting is safe and does not damage wires due to the unique built-in depth of cut stop. The **Roto-Split** spells the **end to nicked fingers and cut knees**. The open channel construction pioneered by Seatek allows cutting in the middle of a roll. **Simplicity at its best!**



Roto-Split BX Cable Cutter

- RS-101A requires no adjustment after initial setting – quick clamp lever does it all. Best of all the cable pops out automatically as soon as a cut is completed.
- Unique patented offset clamping provides no fuss side loading.
- Make cuts in tight quarters. Simply ratchet the handle back and forth when you're in a tight spot.
- Quickly change the blade with only an adjustable wrench thanks to an easy to reach hex nut.
- Self-tightening blade system and ergonomic crank handle with offset for maximum hand clearance.
- Blade storage cartridge in knob with storage for 6 blades.
- Handsome die cast epoxy enameled body. Overall, a tool oozing with quality and smart engineering.

CARRY IT ANYWHERE!

This rugged tool can be carried in your belt pouch or in your hip pocket like a pair of pliers. Always ready when you need it, even on top of a ladder or in hard to reach places.

Item# **RS-101A**



Roto-Split Auto Clamping MC Cable Cutter

The RS-101AC is equipped with an exclusive auto clamping feature. This MC cutter has a clever clamping system which covers the complete cable size range without the need to fuss with a thumb screw. Just squeeze the bottom lever and any cable from 14-2 to 10-4 or 3/8" Flex is secured, no adjustment is required.

Just position any cable size described above in the channel, squeeze and turn the blade handle . . . That's it, no thumbscrew adjustments required. Best of all the cable pops out as soon as the lever is released.

- RS-101AC allows you to safely cut any type of armored cable including the new reduced diameter MC armor by simply changing the depth of cut.
- Make cuts in tight quarters. Simply ratchet the handle back and forth when you're in a tight spot.
- Quickly change the blade with an adjustable wrench thanks to an accessible, easy to remove hex nut.
- Self-tightening blade system and ergonomic crank handle with offset for maximum hand clearance.
- Storage cartridge in knob with room for 6 blades.
- Handsome die cast epoxy enameled body. Overall, a tool oozing with quality and smart engineering.

Split it 2 Times Faster!

Item# **RS-101AC**



Blue Sapphire Replacement Blade

Blue Sapphire universal standard replacement blade for all models of Roto-Split and Roto-Flex. (Not recommended to cut aluminum armor)

Item# **B-102**

Manufacturer's Guaranty: The ROTO-SPLIT has a lifetime guaranty against defects. Any parts (except the circular cutter) will be repaired or replaced free; you pay only the one way shipping charge.

EXPERIENCE THE DIFFERENCE

Equipment - Air Mover

SAHARA PRO X3 TURBODRYER® The ultimate restoration tool

This lower amp, three-speed air mover offers everything restorers need for performance and versatility, plus legendary Dri-Eaz durability and reliability.



Features

- Lower amp draw.
- Daisy-chain capability with convenience outlet and circuit breaker.
- Underside drying vent for drying under the air mover.
- Quick disassembly for cleaning.
- Easy-grip handle.
- Stackable for storage.
- Rugged, built-in-USA durability.

Item# **DRIF351**

ACE TURBODRYER® Six ways to dry



Looking for an air mover that offers six different positions to help you tackle the most difficult drying challenges? Looking for the most CFM per circuit of any air mover on the market? Look no further: it's called the Ace!



Features

- Very low amp draw.
- Six-position versatility for handling a wide range of applications.
- Dry structures fast with 1800 actual CFM.
- Turn or tilt on non-skid rubber feet to switch operating positions.
- Compact design that's stackable for operation and storage.
- Ideal for structural drying, carpet cleaning, ventilation and more!

Item# **DRIF259**

CARPET DRYER / AIR MOVER



The full featured commercial dryer from Powr-Flite has the drying power for every carpet drying, flood restoration and general air circulation requirement. Powr-Flite dryers feature maximum airflow in a streamlined housing designed to reduce performance loss.

Features

- 3-Speed settings for lower amp draw and different drying conditions.
- Unique 4-point motor mounting system reduces noise and vibration.
- Up to 3 operating positions.
- Meets OSHA standards for maximum weight / size.
- Rotationally molded high density polyethylene housing for rugged durability.
- Built-in thermal overload protection protects components in high heat conditions.
- Stackable design provides easy transportation and storage.

Warranty

- 5 Years housing, 1 year parts and labor.

Item# **PFLPD500** (1/2 HP)

Item# **PFLPD350** (1/3 HP)

AXIAL FAN / AIR MOVER



Powr-Flite

For structural and carpet drying you won't find a more effective dryer than the F5 Axial Fan. It gives you versatility you never had before! Built in GFCI outlets allow you to daisy chain up to 6 fans into a standard 15 amp wall outlet perfect for the big jobs when electricity is limited. Use the F5 to dry carpets, rugs, padding, subfloors, baseboards, cabinets, closets, ceilings, attics, furniture, draperies, drywall, paint...anywhere you need high speed drying.

Features

- High CFM of 3000 dries structures fast.
- 2.2 Amp draw means fewer blown circuits.
- 6-Position versatility for every drying need.
- 2-Speed motor for maximum versatility in multiple applications.
- Heavy-duty design and components provide years of service.
- Stack up to five fans for easy transport and storage.

Warranty

- 5 Years housing, 1 year parts and labor.

Item# **PFLPDF5**

Equipment - Air Mover

PHOENIX AXIAL AIR MOVER

The Phoenix Axial Air Mover revolutionized evaporative drying with its patented Focus™ technology which “focuses” high velocity air on hard to dry areas. By maximizing the airflow per amp, typical problem areas – i.e. where the floor meets the wall – are dried faster reducing the chances for secondary damages to occur. AAMs interlock for ease of stacking during storage and transporting. Also comes equipped with: on-board duplex GFCI with 12 amp circuit breaker; automatic hour meter displays site run time; 2 speeds; stainless steel grilles; power-on indicator light.

Specifications

- 3000 CFM
- 2.5 Amps (high speed)
- 15A UL rated GFCI duplex receptacle
- 19.125"W x 19.5"H x 15.2"D
- 29.5 lbs.

Item# **THE4025200**



Phoenix Axial Air Mover

2200 EXtreme/GFCI AIR MOVER

The 2200 EXtreme/GFCI is the ideal air mover for the restorer offering maximum airflow and optimum features while consuming just 2.5 amps. This 2-speed, with its onboard GFCI, allows up to 6 on a single 15 amp circuit making this a must have power house, maintaining its three position airflow, stacking capability, rugged roto molded housing and famous 2-year warranty.



2.5 AMPS

Features

- Daisy-chain capability.
- High velocity air flow.
- Most even airflow.
- Low amp draw.
- Built-in cord wrap.
- Easy grip handle.
- Operating positions: 3 (0°, 45°, 90°).
- Stackable for storage.

Item# **VIK2200EXGFCI**

2200 EX AIR MOVER

The 2200 EX is the ideal air mover for the restorer offering maximum airflow and optimum features while consuming few amps. Maintaining its three position airflow, stacking capability, rugged roto molded housing, famous 2-year warranty, and 2-speed, 3-position switch make this one of our most popular selling units.



2.5 AMPS

Features

- High velocity air flow.
- Most even airflow.
- Low amp draw.
- Built-in cord wrap.
- Easy grip handle.
- Operating positions: 3 (0°, 45°, 90°).
- Stackable for storage.

Item# **VIK2200EX**

ECO CAM AIR MOVER

The ECO Cam Pro single speed centrifugal airmover delivers a powerful 3000 FPM of air while drawing a meager 1.6 amps ± 0.2, making it the greenest air mover on the market today.



1.6 AMPS

Features

- High velocity air flow.
- Most even airflow.
- Lowest amp draw.
- Built-in cord wrap.
- Easy grip handle.
- Operating positions: 3 (0°, 45°, 90°).
- Stackable for storage.

Item# **VIKECOCAM**

PDS-21 WALL CAVITY DRYER

Heat to 205°. There is no air mover motor, no squirrel cage, no attachments. The PDS-21 is an all-in-one containment which makes this revolutionary product easy-to-use for big and small jobs alike. The PDS-21 makes drying easier and less frustrating than before. It is perfect for under sinks or behind cabinets and permanent furniture. Its portability makes drying a breeze. Just drill a 1/2-inch hole, insert desired length of provided tubing, and begin drying.



Item# **VIKPDS-21**

Equipment - Dehumidifier

**LGR 2800i
High Heat Performer.**



The LGR 2800i refrigerant dehumidifier offers exceptional performance across the full range of jobsite conditions – in low humidity environments and even at high temperatures (up to 125°F). The unit is engineered for the heavy demands of water damage restoration and rental use. A rugged rotomolded housing and durable construction make this Dri-Eaz dehumidifier a top choice for professionals everywhere.

Features

- Thermo-hygrometer monitors and displays inlet/outlet conditions.
- Automatic humidistat control.
- Automatic high temperature mode – no manual adjustments.
- Outstanding performance at only 8 amps.
- Remote monitoring ready – track dehumidifier performance automatically.
- Legendary Dri-Eaz rotomolded housing resists dents and scratches – and is easy to keep looking new.

Item# **DRIF410**

**EVOLUTION® LGR
Compact Low Grain Refrigerant Dehumidifier**



The Evolution packs state-of-the-art low grain refrigerant (LGR) technology into a compact design. Built for today's restoration professional, the Evolution also encompasses the most user-friendly features. So versatile and easy to handle that you'll want to use it on every job!

Features

- LGR technology boosts effective operating range.
- Compact size – only 92 pounds.
- Draws only 5 amps – but removes 70 pints/day at AHAM (80°F/60% Rh).
- Quick pump access for easy servicing.
- New, rigid fold-down handle.
- Quick-release hose wrap design.
- Built-in ring for easy attachment of ducting.

Item# **DRIF292**



**LGR 7000XLi
True LGR Performance - Unleashed!**



Removes more water than any other dehumidifier in its category!

Dri-Eaz engineers developed the Advanced Crossflow Technology to maximize energy utilization. At the same time, the unit's built-in sensors constantly monitor real time performance data to automatically calculate ideal operating parameters – such as fan speed and cycle duration – in real-time.

The unit's design also greatly simplifies cleaning and maintenance. Simply remove four bolts and the cover easily lifts off to fully expose the coils and the heat exchange block for easy cleaning.

Features

- Advanced Crossflow Technology maximizes efficiency even in low grain environments. Ensures best performance across range.
- Self-monitoring system. Built-in sensors monitor performance parameters allowing for automatic fan speed adjustments.
- Built-in humidistat and plain-English control panel messages.
- Sealed large-capacity pump basin – more than enough to handle the water from an unintentional defrost that might occur after a power outage or other unexpected shut-down.
- Ergonomic design. Handle 2 in. taller for easier use on stairs, folds down for storage. Integrated cord and hose storage.
- Versatile application – standard 12 in. ductable outlet.
- Legendary rotomolded housing – practically indestructible – resists dents and dings – stackable for storage – saves room in warehouse.

Item# **DRIF412**

**DRIZAIR® 1200
The Classic Refrigerant Dehumidifier**



The DrizAir 1200 dehumidifier has all the convenient features of its larger cousins in a compact and extremely portable size. A proven favorite of water damage restoration professionals!

Features

- Removes up to 15 gallons a day / Super convenient size.
- Hot-gas bypass for fast defrost.
- Rugged rotomolded housing – stackable!
- Electronic touch-pad controls.
- Rigid handle – designed for rugged service.
- Semi-pneumatic wheels for easy transport.
- Built-in duct attachment ring.

Item# **DRIF203**

Equipment - Dehumidifier

PHOENIX LGR DEHUMIDIFIERS

BYPASS™ TECHNOLOGY is a revolutionary patented process that allows Phoenix LGRs to remove water in temperatures as high as 125°F. The process diverts some of the incoming air stream past the evaporator and directs it to the condenser. This permits the refrigeration system head pressures to balance, which results in removing water at higher temperatures. Used in R and HT series LGRs.

Phoenix R Series

Compact, rotomold LGRs with a 20" x 20" footprint and weighing only 105 lbs. that deliver full-sized performance. The smaller, lighter, expertly designed R Series outperforms and outmaneuvers the competition with features including: Patented Bypass™ Technology - for high temperature operation; solid-state controls; stackable rugged plastic housing - resists scratches and dents; 12" inboard wheels; telescoping handle; balanced weight and chamfered corners - maximizes mobility and ease-of-transport; ductable inlet and snap-on duct ring outlet for multiple ducting options; plus impressive air filtration choices are available.



Phoenix R175

- Specifications
- 92 ppd@AHAM
 - 6.3 Amps
 - 230 CFM
 - 20"W x 33.5"H x 20"D
 - 105 lbs.

Item# THE4029200

Phoenix R200

- Specifications
- 125 ppd@AHAM
 - 8.3 Amps
 - 325 CFM
 - 20"W x 33.5"H x 20"D
 - 105 lbs.

Item# THE4027000

Phoenix Stainless 200 Series

Proven™. Phoenix stainless LGRs are a culmination of years of design and manufacturing expertise. Improved water removal and grain depression. Multiple air filter and ducting options.



Phoenix 200 MAX

- Specifications
- 128 ppd@AHAM
 - 7.4 Amps
 - 290 CFM
 - 20"W x 40"H x 18.25"D
 - 131 lbs.

Item# THE4029740



Phoenix HT Stainless Series

Water removal up to 125°F. Solid-state controls. Downward focus exhaust airflow. Recessed 12" wheels. New sleek chamfered corner stainless cabinet. The Phoenix 270HTx adds next-generation patented "automatic" bypass design, which maximizes water removal over extended operating range without manual adjustments by sensing and adjusting to temperature changes in the drying chamber.



Phoenix 200 HT

- Specifications
- 135 ppd@AHAM
 - 7.2 Amps
 - 380 CFM
 - 20"W x 40"H x 23"D
 - 130 lbs.

Item# THE4029970

Phoenix 270HTx

- Specifications
- 161 ppd@AHAM
 - 8.9 Amps
 - 380 CFM
 - 20"W x 40"H x 23"D
 - 130 lbs.

Item# THE4028600

PHOENIX DESICCANT DEHUMIDIFIERS

Phoenix Portable Desiccants

Phoenix Portable Desiccants are the perfect combination of features and performance, allowing the restoration contractor to achieve low grain output and remove water regardless of climate conditions. The D385's four hole design allows set-up for effective positive, neutral or negative pressure and is designed to operate vertically or horizontally. Multiple ducting options make this unit ideal for basements, crawlspaces, attics and almost any speciality drying situation.



Phoenix D385

- Specifications
- 116 ppd@AHAM
 - 115V – 11 Amps ea./ 22 Amps total
 - 385 CFM process airflow
 - 75 CFM reactivation airflow
 - 24.25"W x 40"H x 21.375"D
 - 105 lbs.

Item# THE4026700

EXPERIENCE THE DIFFERENCE

Equipment - Dehumidifier

PHOENIX AIR CONDITIONER

Arctic Max Portable Air Conditioner

Phoenix Arctic Max is compact, durable and affordable. It produces one full ton (12,000 BTUs) of cooling capacity (*95°F/60%RH) using under 12 amps. In a single pass, this provides a 15 degree temperature drop on the 430 CFM evaporator (cooling) air stream and water removal of a "Large" size LGR. The Arctic Max has thermostat controlled cooling to insure maintenance of desired conditions and prevent potential over-cooling. The Arctic Max also features multiple filter and ducting options, and includes an internal condensate pump.



Phoenix Arctic Max

Specifications

- 12,000 BTUs/hr.
- 100 ppd@AHAM
- 11.7 Amps
- Adjustable thermostat range of 60-100°F
- Cooling airflow 430 CFM; Exhaust airflow 430 CFM
- 20.25"W x 40"H x 21.375"D
- 142 lbs.

Item# THE4026850

Equipment - Extraction

HVE 3000 – Portable Flood Pumper and Inline Truckmount Booster



Robust, durable and powerful, the HVE 3000 flood pumper lets you remove water from flooded structures quickly and effectively. Designed with robust restoration features, the unit can also be used as an inline pumpout to boost truckmount performance on long hose runs, enhancing your access to difficult-to-reach areas and accelerating your production.

Pair the HVE 3000 with the Rover HVE or Dri-Eaz extraction tool to remove excess water in large or multi-level units like apartments, hotels,

schools, hospitals, factories, offices, and large residential homes.

High vacuum performance. Dual vacuum blowers and 2 in. inlets and outlets for maximum airflow.

High maneuverability. Unique vacuum hose and housing design makes moving the unit easy – just pull on the hose! Slim profile to fit through the narrowest doors – only 22.5 in. wide.

High capacity waste tank. 12 gal. tank means fewer trips to the drain!

Auto pumpout and quick gravity drain. Standard garden hose connection for auto-pumpout, or use the large toilet-height gravity drain.

Exhaust air passes through HEPA filter. Captures contaminants instead of spreading them!

Features

- Easiest cleanout filter. Just pop the clamps on the clear plastic cover and lift out the basket for rinsing.
- A high flow, high volume clog-resistant sump pump – handles up to ½ inch solids.
- Rugged construction. Rotomolded housing resists dings and scratches. Low center of gravity provides balanced transport; easy on stairs!
- Bypass waste tank for black water flood extraction, keep tank clean.

Item# DRIF479

DRIFORCE® InterAir Drying System™



Dry Walls Without Damage – The DriForce forces high-pressure air into wet walls for wall drying with minimal disruption. You only need to make tiny ¼-inch holes at baseboard level to introduce 38 inches of static pressure from the DriForce! It's perfect for hard-to-reach areas like behind cabinets, tubs, under stairwells, etc.



Complete system includes:

- 1 DriForce air mover
- 13 7-Foot hoses w/cuffs
- 8 Manifolds
- 1 400-Foot coil of PVC tubing
- 100 ¼-in. injector nozzles
- 4 Manifold end caps
- 5 Coupler fittings
- 2 T-fittings
- 25 Tube extender connectors
- 1 Muffler
- 2 Wheeled duffel bags.

Features

- Force air in or vacuum air out.
- Dry up to 90 linear feet of wall.
- Produces up to 38 inches of static pressure!
- Averages just 3 amps.
- Fits in two convenient carrying cases.

Item# DRIF211

RESCUE MAT SYSTEM – Dry hardwoods from above

The Rescue Mat System uses the power of a high-pressure blower like the DriForce to vacuum water vapor right through the surface of the floor. Two different sizes make it easy to custom fit your Rescue Mat System to any floor layout.

Features

- Setup is fast and simple with just one hose connection per mat.
- Two panel sizes for mix-and-match versatility.

Complete system includes:

- 4 large mats (46 × 30 in.)
- 2 medium mats (23 × 30 in.)
- 3 sections of hose with cuffs, 7 ft. each
- 2 connector sleeves
- 6 hose cuffs
- 5 T-connectors
- 1 gasket roll.

Item# DRIF286



Equipment - Extraction

PHOENIX HYDRO-X XTREME XTRACTOR

Hydro-X Xtractor, one restoration technician can extract a 1200 sq. ft. structure with carpet and pad in under 2 hours. No other extractor today pulls as much water from the carpet and pad as the Xtreme

Xtractor. The Xtreme Xtractor can be used with a portable or truckmount vacuum source. Other features include: self-propelled; steering; chain drive; variable speed for every carpet and pad type; extracts in both forward and reverse.



Hydro-X Xtreme Xtractor

- Specifications
- 0-28 FPM – Forward and reverse
 - 2.5 Amps; 110-120VAC
 - 17"W x 52"H x 20.5"D
 - 70 lbs.

Item# **THE4025600**



PHOENIX HYDRO-X VACPAC

Hydro-X Vacuum Pac outperforms the suction power of large, expensive truckmount units. The portable Vacuum Pac, which applies all of its suction power at the source, can be hand-carried anywhere in the structure – unlike truckmount units that must stay outside. The Vacuum Pac features an industrial vacuum and water pump with dual vac motors, and can be run separate from the Hydro-X Xtreme

Xtractor with other extraction tools. Both the Xtractor and VacPac are incredibly maintenance free.



Hydro-X VacPac

- Specifications
- 10" of vacuum suction rating
 - 13.5 Amps - vac motor
 - 4.5 Amps - pump motor
 - 16"W x 26"H x 13"D
 - 74 lbs.

Item# **THE4025601**

GULPER II FLOOD PUMP, 10 GPM



The Gulper II Flood Pump is designed to be the most efficient way to extract water from carpet at any water-damaged facility. It is powerful enough to tackle the toughest recovery jobs, yet is easy to use. Structural damage, electrical hazards, pathogenic bacteria, mold and mildew present very specific cleaning issues at a flood site. The Gulper II is designed specifically for water recovery with a powerful vacuum motor that extracts water and small debris quickly.

Wand sold separately.

Features

- Powerful 10 GPM pump transfers waste water away from flooded area through a standard garden hose.
- Easy accessible filter prevents large debris from entering pumps.
- 25 Feet of 2" vacuum hose provide higher CFM.
- Convenient single power cord operation for added convenience when electrical power is at a premium.

Warranty: 5 Years housing, 1 year motor, parts and workmanship.

Item# **PFLPF85DX**



Equipment - Extraction - Accessory

STAINLESS STEEL WAND WITH HANDLE ONLY

- Features
- 14" Wide
 - 2" Tube
 - Use with Gulper II

Item# **PFLFPW**



EXPERIENCE THE DIFFERENCE

Equipment - Odor Control

RESTORATOR



Heavy-duty electrical unit quickly eliminates odors. Replaceable cartridges provide up to 270 hours of service. 110-volt and 12-volt (car adapter) versions available. Durable steel case with convenient carrying handle. Uses #90-5150-85 refill cartridges (sold separately). The Restorator treats up to 20,000 cu. ft.

Item# **VAP90-5000**



VAPORSHARK INDUSTRIAL ODOR CONTROL SYSTEM



Treats areas up to 50,000 cu. ft. Durable aluminum case. Holds up to five VaporSHARK membranes (sold separately).

Item# **VAP90-0950**

Equipment - Odor Control - Cartridges

S.O.S. (SMOKE ODOR SOLUTION) CARTRIDGES



Specifically formulated for smoke odors. Use with VaporTek Restorator. Provides approximately 270 hours of service.

Item# **VAP90-5150-85**

Item# **VAP90-5150** (3X Industrial Cartridge)

S.O.S. (SMOKE ODOR SOLUTION) MEMBRANES



Specifically formulated for smoke odors. May be used in place of the VaporShark 3X Industrial membranes for smoke odor situations.

Item# **VAP90-0953-85/5**

Item# **VAP0953/5** (3X Industrial Membrane)

HEAVY-DUTY STANDALONE DEODORIZER CARTRIDGE



Non-electric; simply rotate end caps to control air flow. For use in HVAC systems and with high-velocity blowers. Treats areas up to 20,000 cu. ft.

Item# **VAP90-2200-85**

Item# **VAP90-2200** (3X Industrial Cartridge)

Equipment - Fogger

PRORESTORE BLASTMASTER™

Versatile electric fogger makes disinfecting and deodorizing fast and easy.



Constructed of rugged molded polyethylene, the Blastmaster electric fogger is great for duct sealing, deodorizing and disinfecting.

The Blastmaster features ultra-low volume output that produces extremely small particle sizes. This means even dispersal with little waste of product, making it highly effective for use with disinfection and odor control applications. The Blastmaster is suitable for applying water or solvent-based formulations.

Specifications

Formulation tank capacity	1.5 gal. (5.6L)
Hose length.....	48 in. (122cm)
Output.....	Variable from 0-18 oz. (0-0.5kg) per/min.
Dimensions (H x D x W).....	11.5 x 15.25 x 8.25 in. (29.2 x 38.7 x 20.9cm)
Weight.....	~12 lbs. (5.4kg)

Item# **UNS101257000**

PRORESTORE ELECTRO-GEN™

Tackle odors fast and efficiently with the industry's most durable electric thermal fogger.



A versatile odor control application tool, the Electro-Gen produces a true "dry fog" with a particle size similar to that found in smoke – allowing for deep, thorough penetration and virtually eliminating the drips and streaks associated with conventional misters and foggers.

Remove the heater barrel and the Electro-Gen can also be used as an electric sprayer to apply solvent or water-based chemicals for deodorizing.

Specifications

Output.....	1 oz. per minute
Formulation tank capacity	3 quarts
Dimensions: Diameter of base	8 in.
Height.....	11 in.
Barrell Length.....	10 in.
Barrell Diameter.....	3.25 in.
Weight	~5 lbs.

Item# **UNS102257000**



PRORESTORE THERMO-GEN™ VF

The ultimate odor control machine



The Thermo-Gen VF produces extremely fine particles – small enough to allow complete penetration of contaminated surfaces. The fog produced by the Thermo-Gen follows the same path as smoke and odors, reaching into cracks, crevices and voids.

Made of durable stainless steel, the Thermo-Gen VF works with solvent- or water-based solutions. The Thermo-Gen can fog up to 14 gallons of solution per hour with a particle size of .25 to 50 microns. Ideal for use with Thermo-55 or Thermo-2000 fogging agents, the unit incorporates a specially designed cut-off system for added safety.

The fuel tank holds 68 ounces, enough for an hour or more of use before refilling. The unit comes complete with spare parts, filtered funnel and fuel pitcher.

Specifications

Empty weight	15 lbs. (7kg)
Solution tank capacity.....	169 oz. (9L)
Fuel tank capacity	68 oz. (2L)
Engine combustion chamber volume.....	10 oz. (0.3L)
Engine power.....	24 HP
Average fuel consumption.....	136 oz. per/hr.
Application flow rate.....	0-14 gallons per/hr. (dependent on nozzle size)

Ignition.....	6 volt electronic
Dimensions H x W x D	13 x 11.4 x 41.7 in.

Item# **UNS104287000**

Did you know Abatix offers training courses? Located in our Santa Fe Springs, CA, Phoenix, AZ and Jacksonville, FL branches, Abatix Learning Centers offer a variety of certification classes regulated by both governmental and industry related groups, such as OSHA, EPA, Licensing groups (IICRC, IAQA, Maritime, and Construction), as well as product demonstrations and general industry informational sessions. Check our web site for details.

EXPERIENCE THE DIFFERENCE

Equipment - Vacuums



S25 Wet/Dry HEPA Vacuum with power tool outlet

CFM129
 HP1.7
 Amp9,8/4.9
 Volt120/230
 Water lift100
 Weight36 lbs.



- Wet and dry Hepa vacuum with dual, individually tested and certified Hepa filters (2), 8 ft.², 99.99% at 0.3 microns.
- The S25 has an outlet for power tools. The vacuum will start and stop on demand from the power tool.
- Variable speed vacuum motor allows the operator to adjust the amperage and suction power according to circuit breaker capacity.
- The S25 has an automatic filter shaking system. A sensor indicates if a filter is clogged and starts shaking the filter immediately after the vacuum shuts off.
- The compact design makes it easy to transport, carry and to store in vans and trucks.
- The S25 has a 7 gallon tank and lockable front caster. Bags can be used for safer and dust-free emptying of the vacuum.

Item# **ERM200800018A**

S50 Wet/Dry HEPA vacuum with power tool outlet

CFM129
 HP1.7
 Amp9,8/4.9
 Volt120/230
 Waterlift 100
 Weight41 lbs.



- Wet and dry Hepa vacuum with dual, individually tested and certified Hepa filters (2), 8 ft.², 99.99% at 0.3 microns.
- The S50 has an outlet for power tools. The vacuum will start and stop on demand from the power tool.
- Variable speed on the vacuum motor allows the operator to adjust the amperage and suction power according to circuit breaker capacity.
- The S50 has an automatic filter shaking system. A sensor indicates if a filter is clogged and starts shaking the filter immediately after the vacuum shuts off.
- The compact design makes it easy to transport, carry and to store in vans and trucks.
- The S50 has a 14 gallon tank, an ergonomic handle in the chassis and a lockable front caster. Bags can be used for safer and dust-free emptying of the vacuum.

Item# **ERM200800094A**

S13 Single-Phase HEPA Dust Extractor

Model	20090058A
CFM	129
Waterlift	100
HP	1.7
Amps	9.8
Weight (lb)	66
Volts	120

120V single motor HEPA Dust Extractor can be connected to electrical, hand-operated power tools to extract freshly cut, friable concrete dust. The model S13 is also an effective all-around construction vacuum for picking-up a wide range of building materials and debris. Comes with 16-foot, 1.5" hose, wand and floor tool. Includes a 6 mil, 10-gallon disposable poly bag for dust-free handling and disposal.

Item# **ERMS13**



S26 HEPA Dust Extractor

Model	200900059A
Volts	120
HEPA Filter	18 ft. ²
Cartridge Prefilter	18 ft. ²
CFM	258
Waterlift	100
HP	3.4
Amps	19.6
Ship Weight (lb)	103

Unlike low cost homeowner vacuums, Ermator HEPA Dust Extractors are equipped with tested and certified HEPA filters that trap the smallest, most dangerous-to-breath dust particles and prevents them from being released in the air. A HEPA Dust Extractor not only exhausts perfectly clean air, it is far more efficient for the fast recovery of bulk dry dust, debris and other building materials found on every Construction, Abatement and Restoration jobsite. They can also be connected to electrical power tools to extract the freshly cut and friable concrete dust, considered to be the most hazardous to construction workers.

Item# **ERMS26**



PULLMAN-HOLT

Equipment - Vacuums

PULLMAN-HOLT HEPA VACUUMS

HEPA VAC 2HP 10GL 45HEPA-10TT – Wet/Dry

Features

- 10 Gallon / 110 cfm / 105" water lift / 33 lbs.
- Commercial grade, long-life 2HP motor – exceeds airflow and pick-up of vacuums purchased from home improvement stores.
- Compact, low center of gravity design – no tipping and easy handling, transporting and storage.
- Tested and certified HEPA filter – oversized HEPA filter with plenty of media to handle high airflow.
- "Never Clog" Dacron filter bag – self-cleaning, maximizes airflow and prevents interruptions when picking up large volumes of dry, fine dust.
- Positive locking, full swivel hoses – no binding and flexible. Easy handling and storage.
- 50-Foot power cord.
- Includes: 10 ft. x 1.5 in. crushproof hose and 4 ft. x 1 in. power tool connection hose.

Item# **PULB100481**



HEPA VAC 1HP 5GL 86ASB – Wet/Dry

Features

- 5 Gallon / 96 cfm / 85" water lift / 49 lbs.
- Air seal gasket between the motor-head and tanks forms a positive lock fit.
- Heavy gauge steel tank with powder coated finish.
- High efficiency "Drop-in" style HEPA filter individually certified to have a minimum efficiency of 99.97% at .3 microns (based on 1EST-RP-CC007 particle count test method).
- A Dacron filter bag covers the entire spacer sleeve and HEPA filter for three-stage filtration. Dacron material sheds dust to maintain maximum vacuum efficiency.
- Includes complete set of tools.
- 25-Foot power cord.

Tool Kit

- 10 Ft. x 1.5 in. crushproof hose.
- 5 Ft., two-piece metal wand.
- ABS floor brush tool.
- ABS floor squeegee tool.
- Round dusting brush.
- Crevice tool.

Item# **PULB160420**



HEPA VAC 2HP 12GL 102ASB – Wet/Dry

Features

- 12 Gallon / 110 cfm / 105" water lift / 84 lbs.
- High efficiency "Drop-in" style HEPA filter individually certified to have a minimum efficiency of 99.97% at .3 microns (based on 1EST-RP-CC001 particle count test method).
- Air seal gasket between the motorhead and tanks forms a positive lock fit.
- Polyester prefilter is located on the bottom of the HEPA filter, and is held firmly in place with Velcro fasteners.
- A Dacron filter bag covers the entire spacer sleeve and HEPA filter for 3-stage filtration. Dacron material sheds dust to maintain maximum vacuum efficiency.
- Heavy-duty poly tank with large dump valve and vacmobile molded handle and cart for easy transport.
- 25-Foot power cord.

Tool Kit

- 10 Ft. x 1.5 in. crushproof hose.
- 5 Ft., two-piece metal wand with swivel end.
- ABS floor brush tool.
- ABS floor squeegee tool.
- Dusting tool.
- 17 In. crevice tool.

Item# **PULB160421**



HEPA VAC 2HP 10GL 45 – Wet/Dry

Features

- 10 Gallon / 110 cfm / 105" water lift / 10 amps / 43 lbs.
- High efficiency "Drop-in" style HEPA filter individually certified to have a minimum efficiency of 99.97% at .3 microns (based on 1EST-RP-CC007 particle count test method).
- Includes Pullman-Holt's exclusive "Never-clog" Dacron bag for superior pre-filtration.
- Blow molded poly canister with low center of gravity design prevents tipping.
- Positive locking, full swivel hose connection system for easy handling and operation.
- Low noise allows for use in sound sensitive areas.
- Includes complete set of tools.
- 25-Foot power cord.
- 3 Labels to choose from: HEPA, Asbestos and Lead.

Tool Kit

- 10 Ft. x 1.5 in. crushproof hose.
- 5 Ft., two-piece metal wand.
- 17 In. crevice tool.
- Squeegee floor tool.
- Floor brush.
- Round dusting brush.

Item# **PULB160487**



Equipment - Vacuums

PULLMAN-HOLT HEPA VACUUMS

HEPA VAC 2HP 10GL 45 – Dry

Features

- 10 Gallon / 110 cfm / 105" water lift / 36 lbs.
- High efficiency "Drop-in" style HEPA filter individually certified to have a minimum efficiency of 99.97% at .3 microns (based on 1EST-RP-CC001 particle count test method).
- Includes Pullman-Holt's exclusive "Never-clog" dacron bag for superior pre-filtration.
- Blow molded poly canister with low center of gravity design prevents tipping.
- Positive locking, full swivel hose connection system for easy handling and operation.
- Low noise allows for use in sound sensitive areas.
- Includes complete set of tools / 25-Foot power cord.

Tool Kit

- 10 Ft. x 1.5 in. crushproof hose.
- 5 Ft., two-piece double bend metal wand.
- 17 In. crevice tool.
- Floor brush tool.
- Round dusting brush.

Item# **PULB160414**



HEPA VAC 1HP 5GL 86ASB5D4C – Dry

Features

- 5 Gallon / 96 cfm / 85" water lift / 44 lbs.
- Air seal gasket between the motorhead and tanks forms a positive lock fit.
- Heavy gauge steel tank with powder coated finish.
- High efficiency "Drop-in" style HEPA filter individually certified to have a minimum efficiency of 99.97% at .3 microns (based on 1EST-RP-CC001 particle count test method).
- A Dacron filter bag covers the entire spacer sleeve and HEPA filter for three-stage filtration; Dacron material sheds dust to maintain maximum vacuum efficiency.
- Includes complete set of tools.
- 25-Foot power cord.

Tool Kit

- 10 Ft. x 1.5 in. crushproof hose.
- 5 Ft., two-piece double bend metal wand.
- ABS floor brush tool.
- Round dusting brush.
- Crevice tool.

Item# **PULB160419**



PULLMAN-HOLT

HEPA VAC 1.5HP 4GL 390ASB – Canister – Dry Only

Features

- 4 Gallon / 11.8 amps / 97" water lift / 18 lbs.
- A quiet, yet powerful 1.5 HP motor provides the suction of vacuums twice its size.
- HEPA filters are individually tested and certified to have a minimum efficiency of 99.97% at .3 microns based on particle count test method, 1EST-RP-CC001.
- **Meets and exceeds EPA's RRP (Renovation, Repair and Painting) rule that requires the use of a HEPA vacuum when sanding, grinding, cutting and for clean-up activities.**
- Convenient onboard tool and power cord storage.
- Low profile design prevents tipping while providing greater mobility.
- Durable chrome plated steel tank is attractive yet rugged.
- Conveniently located foot activated on/off switch.
- 25-Foot power cord.

Tool Kit

- 6 Ft. hose.
- Telescopic steel wand.
- Two-position ergo slide floor tool.
- Dusting tool.
- Upholstery tool.
- Crevice tool.

Replacement Filters

- HEPA filter - PULB160534
- Disposable paper filter bag - PULB600900

Item# **PULB160535**



HEPA VAC 1HP 6QT 30ASB – Backpack – Dry

Features

- 6 Quart / 101 cfm / 85" water lift / 32 lbs.
- Heavy-duty steel tank with powder coated finish.
- High efficiency "Drop-in" style HEPA filter individually certified to have a minimum efficiency of 99.97% at .3 microns (based on 1EST-RP-CC001 particle count test method).
- Includes 10 ft. crush proof hose and dusting brush.
- Top fill design allows for maximum capacity.
- 50-Foot power cord.

Item# **PULB160000**



Equipment - Vacuums - Hoses / Tools

HOSE ASSEMBLY

Replacement hose assembly.

Features

- Crushproof hose.
- 1.5" x 10'.
- Black.
- For 102ASB, 86ASB and 30ASB vacuums.

Item# **PULB000311**



HOSE ASSEMBLY

Replacement hose assembly.

Features

- No wire flex hose.
- 1.5" I.D x 50'.
- Black.

Item# **PULB000310**



HEPA FILTER ASSEMBLY

Replacement filter assembly.

Features

- HEPA filter.
- For 390ASB vacuum, (PULB160535 Dry Canister).

Item# **PULB160534**



Abatix' online ordering system is simple to use. Once you are registered and have a customer code, you can create orders, customize shopping lists, and view ordering history, track shipments, view and print invoices and pay bills online. Head over to www.abatix.com and start shopping today.

Looking for or considering a vending solution? With Abatix Supply Advantage Program – A.S.A.P. vending solutions you could reduce supply costs and improve productivity. Check out our web site to find out more about our A.S.A.P. vending solutions.

PULLMAN-HOLT

ROUND DUST BRUSH 2" x 1.5" DIA

2-Inch round nylon bristle brush for dusting and above floor cleaning.

Item# **PULB000394**



FLOOR BRUSH TOOL 14" x 1.5" DIA

14-Inch floor brush tool with nylon bristles for cleaning hard floors.

Item# **PULB527095**



WAND DBL BEND 5' 2PC 1.5" DIA

5-Foot, two-piece double bend wand with tool coupling attaches to floor tools.

Item# **PULB521007**



TOOL KIT WET/DRY 86 102 VAC

102 and 86 Series replacement tool kit includes crushproof hose assembly, steel double bend wand and 1.5-inch diameter tools for wet and/or dry pick up applications.

Item# **PULB160426**



EXPERIENCE THE DIFFERENCE

Equipment - Vacuums - Filters

HEPA FILTER

Replacement HEPA filter to fit Pullman-Holt 45ASB Vacuums

Materials

- Casing: Plastic
- Media: Glass
- Sealant: Urethane

Efficiency: Minimum 99.97% on .3 microns as tested in accordance with IEST-RP-CC007.

Capacity: 115 CFM @ 1.0 inches W.G.

Item# **PULB702340**



SPACER SLEEVE

Replacement Spacer Sleeve for Pullman-Holt 86ASB and 102ASB Vacuums

The spacer sleeve to use with HEPA Filter# PULB160009 and HEPA Filter# PULB526520.

Item# **PULB700306**



HEPA FILTER

Replacement HEPA filter to fit Pullman-Holt 102ASB Vacuum

Materials

- Casing: Plastic
- Media: Glass
- Separator: Aluminum
- Gasket: Neoprene
- Sealant: Urethane
- Pre-filter: Polyester

Efficiency: Minimum 99.97% on .3 microns as tested in accordance with IEST-RP-CC007.

Capacity: 100 CFM @ 1.2 inches W.G.

Item# **PULB160009**



PAPER COLLECTION BAG

Replacement Bags for Pullman-Holt 45ASB and 86ASB Vacuums

Two-ply paper collection bag.

Item# **PULB700408**

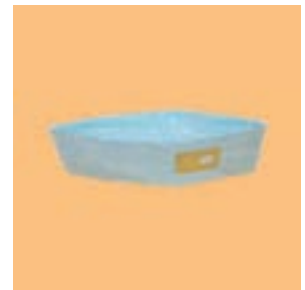

HEPA FILTER

Replacement HEPA filter to fit Pullman-Holt 86ASB Vacuums

Materials

- Casing: Plastic
- Media: Glass
- Separator: Aluminum
- Gasket: Neoprene
- Pre-filter: Polyester

Efficiency: Minimum 99.97% on .3 microns as tested in accordance with IEST-RP-CC007.

Capacity: 100 CFM @ 1.2 inches W.G.

Item# **PULB526520**



PAPER FILTER BAG 390 VAC

Model 390CV / 390ASB disposable paper filter bag.

Item# **PULB600900**



PAPER FILTER BAG DISP 102ASB

2-Ply paper filter bag acts as primary filter to trap and hold dry material.

Item# **PULB524253**



HEPA FILTER

Replacement HEPA filter to fit Euroclean UZ930 and Nilfisk GD930 Vacuums

Materials

- Casing: Plastic
- Media: Glass
- Sealant: Urethane

Efficiency: Minimum 99.97% on .3 microns as tested in accordance with IEST-RP-CC007.

Capacity: 85 CFM @ 1.5 inches W.G.

Item# **EUR1402666010**



NEVER CLOG FILTER BAG 14" DIA

"Never-clog" Dacron bag sheds dust to maintain maximum vacuum efficiency. Superior pre-filtration.

Item# **PULB000517**





Equipment - Vacuums

NILFISK ELIMINATOR I VACUUM CLEANERS



The Eliminator I Vacuum Cleaner is compact and designed to withstand the abuse of a rugged environment, while maintaining strong suction and filtration capabilities. The multi-stage filtration system features a HEPA filter that captures 99.97 percent of dust and debris, down to and including 0.3 microns. The standard model is configured for dry material collection; however, the Eliminator I is also available as a wet/dry vacuum with the addition of a factory-installed float chamber device. As a member of the Eliminator family of vacuums, all filters, accessories, and hoses are interchangeable within the Eliminator line.

Included Accessories
50-foot yellow safety cord, 10-foot hose with curved aluminum wand, 2 extension wands, dust brush, crevice nozzle and a floor tool with 3 inserts, each designed for a specific floor surface.

Item# **NIL9058909010**
Item# **NIL9058913010** (wet/dry)

NILFISK GD10 BACK VACUUM



The GD10 Back Vacuum was designed with comfort and ease of use in mind. For its small size, the vacuum is incredibly powerful and equipped with a variety of features for fast, effective cleaning in a multitude of industries.

Included Accessories
Combination floor nozzle, dust brush, crevice cone and telescopic wand.

Item# **NIL9060709010**

ELIMINATOR II VACUUM CLEANER



The versatile, easily maneuverable Eliminator II Vacuum Cleaner is ideal for wet or dry collection of dust and debris. A 12 gallon capacity container and efficient motor ensure minimal maintenance. It is specifically designed to withstand the abuse of a rugged environment, while maintaining strong suction and filtration capabilities. The multi-stage filtration system features a HEPA filter that captures 99.97 percent of dust and debris, down to and including 0.3 microns. As a member of the Eliminator family of vacuums, all

filters, accessories and hoses are interchangeable within the Eliminator line.

Included Accessories
50-foot yellow safety cord, 10-foot hose with aluminum curved wand, 2 telescopic wands, dust brush, crevice nozzle, and a floor tool with 3 inserts, each designed for a specific floor surface.

Item# **NIL9058910010**

NILFISK GD930 VACUUM



The ever-popular GD930 is a canister vacuum cleaner designed for solid performance in abusive environments. Its tremendous suction power and durable construction make it a reliable choice for demanding applications, such as mold or asbestos remediation. A

superior filtration system, including a standard HEPA filter, ensures a safer work environment.

Included Accessories
HEPA-Filtered Vacuum with 1000 Watt motor includes: 6' hose assembly with bent wand, telescopic wand, combination floor nozzle, crevice tool, combination round dust brush/upholstery tool and one paper bag.

Item# **NIL9055314040**

Equipment - Vacuums - Filters



ELIMINATOR I PAPER BAGS
Item# **NIL1470745010** (3/pk)



ELIMINATOR II PAPER BAGS
Item# **NIL1470746010** (3/pk)



ELIMINATOR I & II HEPA FILTER COMPLETE
Retains 99.97% of dust and debris, down to and including 0.3 microns.
Item# **NIL1408678500**



ELIMINATOR I & II MAIN FILTER
Item# **NIL1408658500**



GD10 BACK VACUUM REPLACEMENT DUST BAGS
Item# **NIL1471097500** (5/pk)



GD10 BACK VACUUM REPLACEMENT FILTER, UPSTREAM
Item# **NIL1471104500**

EXPERIENCE THE DIFFERENCE

Equipment - Vacuums

OMEGA HEPA ABATEMENT VACUUM

The Omega Abatement 1 Gallon HEPA dry particulate vacuum is an excellent portable choice for hazardous particulate cleanup. ULPA filter option for even the most demanding applications.

HEPA Efficiency: 99.97% @ .3 micron



Features

- True HEPA Filter.
- Portable / Quiet.
- Hose and Filter Plugs for Safety.
- Powerful 1,000 Hour Motor.

Applications/Industries

- RRP, Renovate Repair and Paint / Glove Bag, Core Sampling.
- Abatement / Lead / Mold - Early and final gross removal.
- Hazardous Particulate

Item# **ATROV1000A**



Equipment - Vacuums - Filter



HEPA FILTER

Replacement filter for Omega HEPA Abatement Vacuum

99.97% @ .3 micron

Item# **ATROF612HE**

Equipment - Vacuums

SHOP-VAC® QUIET - WET/DRY



**16
Gallons**

**6.5
Peak HP**

Features

- Cord length: 12 feet.
- Operation sound level: Super Quiet.
- Hose size: 2.5" diameter.
- Warranty: 3 years.
- Tank drain / Blower feature.
- Onboard accessory storage.

Performance

- Air Flow: 210 (CFM)
- Sealed Pressure: 60 (inches)
- Electrical Ratings: 120V 60Hz 12Amps
- Peak Air Watts: 390

Item# **SHV586-75-00**

Includes

- 2-1/2" Dia. x 8' hose
- (2) 2-1/2" Wands
- 14" Nozzle with brush and squeegee shoes
- Crevice tool
- Accessory storage
- Cartridge filter
- Collection bag

SHOP-VAC® QUIET - WET/DRY



**12
Gallons**

**4.5
Peak HP**

Features

- Cord length: 6 feet.
- Operation sound level: Super Quiet.
- Hose size: 1.25" diameter.
- Warranty: 2 years.
- Blower feature.
- Onboard accessory storage.

Performance

- Air Flow: 175 (CFM)
- Sealed Pressure: 60 (inches)
- Electrical Ratings: 120V 60Hz 9Amps
- Peak Air Watts: 320

Item# **SHV586-72-00**

Includes

- 1-1/4" Dia. x 7' hose
- (3) 1-1/4" Extension wands
- 10" Wet/dry nozzle
- Foam sleeve
- Reusable dry filter
- Collection bag

Equipment - Air Scrubber



AEROCLEAN 600 MAG

- Air capacity 675 CFM high speed, 450 CFM low speed.
- Motor: 1.0 HP (two speed switch).
- 26"L x 18"W x 18"H, 80 Lbs.
- Slide down doors for E-Z accessibility.
- Four (4) casters for E-Z mobility.
- 12" Exhaust.
- Filters: 1st Stage – 16" x 16" pre-filter
2nd Stage – 16" x 16" x 1" ring panel
3rd Stage – 16" x 16" x 5-7/8" HEPA filter.

Item# **AER9145**

AEROCLEAN 2000 "TURBO AIR"

- Air capacity 2100 CFM high speed, 1400 CFM low speed.
- Motor: 1.75 HP (two speed switch).
- 33"L x 26"W x 26"H.
- 150 Lbs.
- Slide down door and four (4) casters for E-Z mobility.
- 12" Exhaust.
- Filters: 1st Stage – 24" x 24" pre-filter
2nd Stage – 24" x 24" x 1" ring panel
3rd Stage – 24" x 24" x 11-7/8" HEPA filter.

Item# **AER9100**

Item# **AER9103H** (With Hour Meter)

AEROCLEAN 9180 "MIGHTY MITE"

- Air capacity 1850 CFM high speed, 1200 CFM low speed.
- Motor: 1.0 HP (two speed switch).
- 33"L x 18"W x 26"H.
- 115 Lbs.
- Slide down door and four (4) casters for E-Z mobility.
- 12" Exhaust.
- Filters: 1st Stage – 24" x 16" pre-filter
2nd Stage – 24" x 16" x 1" ring panel
3rd Stage – 24" x 16" x 11-7/8" HEPA filter.

Item# **AER9180**

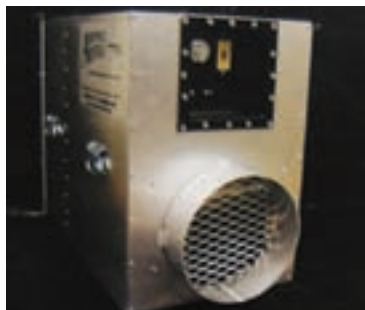

A600 AIR SCRUBBER



- Quiet.
- 0.25 Hp motor.
- 2.1 Amps.
- Two airflow speeds – 300 and 600 CFM.
- Airflow is directed upwards to avoid disturbing dust on surfaces.
- Primary Filter – Disposable polyester media.
- Secondary HEPA Filter – 99.99% efficient @ .3 microns.
- Secondary HEPA Filter – 56 ft.²
- An orange warning light indicates when the washable primary filter is 75% clogged and requires cleaning.
- Leakage/Broken HEPA Filter Indicator – Red indicator light.
- One, top handle.
- Shipping weight 45 lbs.
- Net weight 41 lbs.
- 15"L x 17"W x 17"H.
- Sturdy, compact cabinet.

Item# **ERM200900061A**



DEFENDAIR HEPA 500



- Small footprint.
- Advanced filtration technology.
- Daisy chain capability – link up to 3 units on 1 power outlet.
- Spread units around space to increase effectiveness.
- Variable CFM on each unit – up to 1500 CFM per 15-amp circuit.
- Stackable, lightweight and easily transportable.

Item# **DRIF284**

EXPERIENCE THE DIFFERENCE

Equipment - Air Scrubber

OMNIAIRE ODIOA600V – Lightweight, Portable Negative Air Machine

Airflow - 150-600 cfm (Airflows are based on blower manufacturer curves. Different HEPA filters may cause the flow to vary.)

Weight - 55 lbs. **Dimensions** - 14"W x 18.5"H x 30.5"L

Filtration - Primary/Secondary Filter - Dual-ply Dustlok polyester pad, **Standard HEPA Filter** - Wood frame 99.97% efficiency .3 micron, **Optional HEPA Filter** - Metal frame 99.99% efficiency .3 micron individually certified, **Optional** - Carbon filter for odor control.

Power Requirement - 115 VAC/ 50-60 Hz 3.5 amps.

Cabinet - Aircraft grade aluminum, closed end rivet construction.

All seams are silicone sealed before riveting. Four hospital grade non-marking 3" casters.

Controls - Variable speed controller, Pressure gauge - 0" to 3".

Outlet Ring Size - 8" diameter.

Item# **ODIOA600V**

Item# **ODIMFIM8** Intake Manifold, ABS plastic, 14" x 13" with 8" duct ring

OMNIAIRE ODIOA1000V – Medium Duty Negative Air Machine

Airflow - 350-900 cfm (Airflows are based on blower manufacturer curves. Different HEPA filters may cause the flow to vary.)

Weight - 75 lbs. **Dimensions** - 18"W x 21"H x 32"L

Filtration - Primary/Secondary Filter - Dual-ply Dustlok polyester pad, **Standard HEPA Filter** - Wood frame 99.97% efficiency .3 micron, **Optional HEPA Filter** - Metal frame 99.99% efficiency .3 micron certified, **Optional** - Carbon filter for odor control.

Power Requirement - 115 VAC/ 50-60 Hz 5.8 amps.

Cabinet - Aircraft grade aluminum, closed end rivet construction.

All seams are silicone sealed before riveting. Four hospital grade non-marking 3" casters.

Controls - Speed selector switch, Variable speed controller,

Pressure gauge - 0" to 3", Digital hour meter.

Outlet Ring Size - 10" diameter.

Item# **ODIOA1000V**

OMNIAIRE ODIOA2200C – 24" x 24" HEPA Filter Negative Air Machine

Airflow - 1000/2000 cfm (Airflows based on blower manufacturer curves. Different HEPA filters may cause the flow to vary.)

Weight - 145 lbs. **Dimensions** - 26"W x 31"H x 34"L

Filtration - Primary/Secondary Filter - Dual-ply Dustlok polyester pad, **Standard HEPA Filter** - Wood frame 99.97% efficiency .3 micron, **Optional** - Carbon filter for odor control.

Power Requirement - 115 VAC/ 50-60 Hz 12.0 amps.

Cabinet - Galvanized steel cabinet, closed end rivet construction. All seams are silicone sealed before riveting. Four (4) hospital grade non-marking 5" casters.

Controls - Speed selector switch, Change filter indicator.

Outlet Ring Size - 12" diameter.

Item# **ODIOA2200C**

Item# **ODIOAIM2200-12** Intake Manifold, ABS plastic, 26" x 26" with 12" duct ring



Intake manifold available



PHANTOM CONTRACTOR GRADE HEPA AIR FILTER, Air Scrubber - Negative Air Machine

- The true HEPA filter removes airborne particles down to .3 micron in size with 99.97% efficiency.
- The unit also uses replaceable primary and secondary filters to improve the life of the HEPA filter. Easily replaced filters are available from various sources.
- Four heavy-duty 4-inch casters coupled with four spring-loaded handles make transfer easy.
- The airtight case made of corrosion resistant heavy gage galvanize seals with Iron Grip neoprene material, and the door quickly opens and closes with a link lock latch.
- A unique custom designed 1.75 HP motor and dynamically balanced blower mounts in a tripod fashion using rubberized bushings designed to dampen vibration and minimize noise.
- Carefully engineered tolerances avoid motor shift, rubbing or drag.
- Power to the unit is standard 120 VAC.
- The built-in Minihelic pressure gauge helps determine when filters need to be replaced.
- 1-Year factory warranty.

Item# **ADCPH2000**



Equipment - Air Scrubber - Filters

Abatix carries many different filters to ensure that your negative air machine is running at peak performance. If you do not see the size you need, please contact your local ABATIX office.

PRIMARY FILTERS – Synthetic fiber for economical pre-filtration

- Item# **FLTP2424** 24" x 24"
- Item# **FLTP1824** 18" x 24"
- Item# **FLTP1818** 18" x 18"
- Item# **FLTP1616** 16" x 16"
- Item# **FLTP1313** 13" x 13"
- Item# **FLTP1212** 12" x 12"



SPECIALTY FILTERS – Carbon pleated filter for odor removal

- Item# **FLTC2424-T3** 24" x 24" x 2"
Carbon Tri-Sorb III
- Item# **FLTC2424** 24" x 24" x 2"
- Item# **FLTC1818** 18" x 18" x 2"
- Item# **FLTC1616** 16" x 16" x 2"
- Item# **FLTC1212** 12" x 12" x 2"



RING PANEL FILTERS – Metal frame for rigidity

- Item# **FLTR2424** 24" x 24"
- Item# **FLTR1824** 18" x 24"
- Item# **FLTR1818** 18" x 18"
- Item# **FLTR1616** 16" x 16"
- Item# **FLTR1313** 13" x 13"
- Item# **FLTR1212** 12" x 12"



HEPA FILTERS – 99.97% HEPA filtration

- Item# **FLTH2424** 24" x 24"
- Item# **FLTH1824** 18" x 24"
- Item# **FLTH1616** 16" x 16"
- Item# **FLTH1212** 12" x 12"



SECONDARY FILTERS – Pleated for more surface area

- Item# **FLTS2424** 24" x 24"
- Item# **FLTS1824** 18" x 24"
- Item# **FLTS1818** 18" x 18"
- Item# **FLTS1616** 16" x 16"
- Item# **FLTS1313** 13" x 13"
- Item# **FLTS1212** 12" x 12"



HEPA 500 FILTERS (8 pk)

Restore your DefendAir HEPA 500 air scrubber to maximum capacity.

- Item# **DRIF321**



ACTIVATED CARBON FILTERS (4 pk)

Optional filter boosts HEPA 500 functionality.

The activated carbon filter now equips the HEPA 500 to capture a wide variety of volatile organic compounds (VOCs), including soot and smoke, food odors, fumes from paint and paint thinners, sewer odors and many other compounds.



Features

- Captures a wide variety of volatile organic compounds (VOCs).
- Utilizes Extruded Activated Carbon – carbon pellets manufactured to uniform size helps to ensure maximum airflow and maximum contact.
- Works by adsorption, carbon filtration's natural ability to attract and hold gas and liquid molecules on its surface.
- One pound of carbon has 534,438 square yards of available surface – equivalent to the area covered by more than 100 football fields.

- Item# **DRIF397**

Equipment - Air Scrubber - Accessory

INLET MANIFOLD

Molded plastic inlet manifold with 12" diameter flex duct collar for air scrubbers.

24" x 24" outside dimensions.

- Item# **ABTH2080P**



Equipment - Accessory

FLEX DUCT

- Flexible air hose.
- For medium and low pressure systems.
- Non-insulated.
- Air venting.
- Drying applications.
- 25-Foot sections.

- Item# **FLEFD08** (8" Diam.)
- Item# **FLEFD10** (10" Diam.)
- Item# **FLEFD12** (12" Diam.)
- Item# **FLEFD14** (14" Diam.)
- Item# **FLEFD18** (18" Diam.)



POLY TUBING BAGS

Item#	Size	Mil	Color	Dia.
BAGLF12-500	19.5" x 500'	4	Clear	12"

EXPERIENCE THE DIFFERENCE

Equipment - Power Washers

CONTRACTOR POWER WASHERS

POWERFUL SUBARU OHV ENGINE

- Automatic system protection cuts power to the unit if oil runs low.

PROFESSIONAL-GRADE BELT-DRIVEN, TRIPLEX PUMP

- Ceramic-coated pistons for long life.

PROFESSIONAL-GRADE SPRAY GUN

- Adjustable side handle provides precise control.
- Cushion grip and ergonomic reverse trigger reduce user fatigue.

PRESSURE CONTROL VALVE

- Provides complete control of water pressure for all applications.

QUICK-CLICK™ NOZZLE TIPS

- Four included, for tackling any job.

NON-MARRING, STEEL BRAIDED HOSE

- Will not leave scuff marks on surfaces.
- Quick connectors make hose connections a snap.

DURABLE HEAVY-DUTY STYLE FRAME

- Protects the engine and pump.
- Front grab bar makes it easier to lift.

GENERAC



Item# **GEN6228**
3000psi @ 3.0 gpm

Item# **GEN6229**
3500psi @ 3.7 gpm

Item# **GEN6230**
4000psi @ 3.4 gpm

Specifications

Outlet Pressure - PSI/BAR	3000/207	3500/241	4000/276
Flow Rate - (GPM)/(Liters/min)	3.0/11/4	3.7/14.0	3.4/12.9
Retail (50 State)	0062280	0062290	0062300
Engine			
Engine Manufacturer	Subaru	Subaru	Subaru
Engine Displacement - CID/cc	16.2/265	24.7/404	24.7/404
Engine Type	OHV (Over Head Valve)	OHV (Over Head Valve)	OHV (Over Head Valve)
Engine Orientation	Horizontal	Horizontal	Horizontal
Low Oil Shut Down System	Yes	Yes	Yes
Fuel Capacity - qts/L	5.9/5.6	7.2/6.8	7.2/6.8
Fuel On/Off Switch	Yes	Yes	Yes
Oil Capacity - oz/L	33.8/1.0	40.6/1.2	40.6/1.2
Recommended Engine Oil	SAE 30 or 10W30	SAE 30 or 10W30	SAE 30 or 10W30
Throttle Control	Manual	Manual	Manual
Choke	Manual	Manual	Manual
Starting Method	Manual	Manual	Manual
On/Off Switch	Yes	Yes	Yes
Pump			
Pump Type	Triplex		
Plunger	Ceramic-coated Stainless Steel		
Material	Aluminum Body & Brass Head		
Water supply temperature - °F/°C	100/38 Max		
Hose			
Hose length - ft/m	50/15.2		
Hose Material	Non-Marring Steel Braided		
Hose Diameter- in/mm	3/8 / 9.5		
Hose Rating	4000 psi		
Hose Connectors	Quick Change		
Nozzles			
Nozzles - Number per unit	4		
Nozzles - Description	0, 15, 25, 40		

Emissions Certification: 50-State

Gun & Lance				
	Gun	Professional w/adjustable side handle	Professional w/adjustable side handle	Professional w/adjustable side handle
Gun to Lance Connection	M22 Threaded	M22 Threaded	M22 Threaded	M22 Threaded
Gun to Hose Connection	Quick Change	Quick Change	Quick Change	Quick Change
Lance Length- in/cm	20/51	33/84	33/84	33/84
Lance to Nozzle Connection	Quick Change	Quick Change	Quick Change	Quick Change
Lance Material	Stainless Steel	Stainless Steel	Stainless Steel	Stainless Steel
Lance Connector Material	Brass	Brass	Brass	Brass
Warranty				
	Warranty	Limited	Limited	Limited
Frame & Misc.				
	Handle Construction	Fixed Durable Welded Steel	Fixed Durable Welded Steel	Fixed Durable Welded Steel
	Wheels	5" x 13" Pneumatic	5" x 13" Pneumatic	5" x 13" Pneumatic
Dimensions and Weights				
	Length (L) - in	39.5	39.5	39.5
	Width (W) [Wheel to Wheel] - in	28.5	28.5	28.5
	Height (H) - in	26.0	26.0	26.0
	Dry weight including hose, gun & lance - lbs	178	191	191
	Shipping Weight - lbs	232	245	245

Fans - Floor and Pedestal



CF-20

20" Commercial Floor Fan – CF-20

Motor: 3-speed, 1/5 hp, open ventilated, permanently lubricated, sleeve bearing

Switch: Rotary

Cord: 7' long – SJT type 3 conductor

Guards: Chrome plated steel with retaining clips

Blade: Aluminum

CFM: High-3450; Med-3100, Low-2950

Max Amps: 1.9

1-Year limited warranty

Meets OSHA standards

Item# **CF-20**



CACU30-P

30" Commercial Pedestal Fan – CACU30-P

Motor: 2- or 3-speed, 1/4 hp, 120V, 1 Ph., ball bearing, open ventilated, permanently lubricated permanent split capacitor.

Switch: Pull chain

Cord: 9' long – SJT type 3 conductor

Guards: Chrome plated steel with retaining clips

Blade: Steel hub/spider and aluminum paddles

Pole: Adjusts center of fan from 43" to 60"

CFM: High-6000; Low-4800

Comes as a complete assembly including fan head and pedestal mount.

1-Year warranty

Meets OSHA standards

Item# **CACU30-P**

42" Commercial Belt Drive Blower – CPB42-B

Motor: 2-speed, 1/2 hp, 120V, open ventilated, permanently lubricated, ball bearing.

Switch: Rocker

Cord: 8' long –SJT type 3 conductor

Guards: Spiral wire – front and rear

Blade: Aluminum

CFM: High-13,500; Low-11,000

Max Amps: 6.5

Powder coated 20-gauge steel housing

8" Rubber wheels

1-Year limited warranty

Meets OSHA standards

Item# **CPB42-B**



CPB42-B

First Aid Kits

ABATIX FIRST AID KITS



Kits contain economic bulk supplies that can be readily accessed when needed. They are ideal for manufacturing settings where a wide variety of first aid items are required. All kits are waterproof and are available in plastic or metal.

All bulk kits are ANSI Z308.1-2003 compliant.

- Item# **FAK2010E** (10 Person - Plastic Case)
- Item# **FAK2025SK** (25 Person - Plastic Case)
- Item# **FAK2025E** (25 Person - Metal Case)
- Item# **FAK2050E** (50 Person - Metal Case)

Kit Contents

Description	10 Person	25 Person	50 Person
Adhesive bandage, 1" x 3", plastic	16	32	100
Adhesive bandage, fingertip, woven	1	3	4
Adhesive bandage, knuckle, woven	-	2	3
Adhesive bandage, extra large, plastic	1	1	2
Adhesive tape, 1/2" x 2-1/2 yd.	2	2	2
Antiseptic wipes, BZK	6	6	12
Conforming bandage, 2" x 6 yd., non-sterile	1	2	3
Conforming bandage, 3" x 6 yd., non-sterile	1	1	2
CPR Filtershield™	-	1	1
Elastic bandage, 2" x 4-1/2 yds.	-	-	1
Eye-Lert®, 1 oz. eyewash	-	1	1
Eye pad, sterile	-	1	2
First aid/burn cream with aloe	6	6	12
First aid guide	1	1	1
Forceps, pointed, plastic	1	1	1
Instant Cold Pak	1	1	2
Pain-A-Rest®, non-aspirin	3	3	6
Poison control directory	1	1	1
Scissors, angled, red handle	1	1	1
Antibiotic ointment	6	6	12
Sterile gauze pads, 2" x 2"	4	4	10
Sterile gauze pads, 3" x 3"	1	1	2
Sting relief wipes	6	6	12
Medical gloves, synthetic, (pair)	4	4	4
Trauma pad, 5" x 9", sterile	1	1	1
Triangular bandage, 40" x 40" x 56"	1	1	1



ABATIX INDUSTRIAL FIRST AID STATION

Abatix industrial first aid stations contain a wide variety of medicinal, wound care and assorted first aid products, equipped to handle minor injuries or aches and pains that may occur in the work environment. This large industrial station has 4 shelves, pump spray and an inner liner to hold loose items. Cabinet is made of rugged steel.



Station Size: 15" x 22" x 5-1/2"

Item# **FAK2100E** (100 Person - Metal Cabinet)

Station Contents

Description	100 Person
Adhesive bandage, 1" x 3", plastic	100
Adhesive bandage, 1" x 3", woven	50
Fingertip bandage, woven, "T"	40
Fingertip bandage, woven, "8"	25
Woven patch bandage, 2" x 3"	25
Knuckle bandage, woven	40
Gauze bandage, 2"	6
Triangular bandages	2
Bloodstopper	2
Gauze pads, 2" x 2"	25
Gauze pads, 4" x 4"	25
Non-adherent pads, 2" x 3"	50
Non-adherent pads, 2" x 3"	1
Co-Flex, 2" x 5 yds.	1
Tri-Cut tape	1
Elastic tape, 1" x 5 yds.	1
Triple biotic foil packs	20
Antiseptic wipes	20
Alcohol wipes	50
Ammonia inhalant	10
Burn spray, 3 oz.	1
First aid spray, 3 oz.	1
Cold pack, 6" x 9"	1
Cold pack Jr.	1
Eye wash, 4 oz.	1
Aspirin	250
Aypanal	250
Miralac antacid	250
Multi-symptom cold	100
Scissors, 3-3/4"	1
Tweezers, slant end	1
Biohazard waste bags	2
Gloves (pair)	2
Cotton tips, 3"	100
Tongue blades	6
First aid and CPR book	1

Hand Tools - Tape Measures

Chrome Case Power Tape



616

- High impact resistant ABS body.
- Bold clear numbers on bright yellow tape.
- Rigid blade with protective nylon coating.
- Durable steel belt clip.
- Dependable slide lock.
- Triple Riveted, Reinforced Dual-End Hook for long lasting durability.
- Ergonomic design for comfort.

- 610 - 10' x 5/8" Blade
- 612 - 12' x 5/8" Blade
- 616 - 16' x 3/4" Blade
- 626 - 25' x 1" Blade
- 636 - 30' x 1" Blade

Series P1000 and P2000 Power Return Tapes

P1000 Hi-Viz® orange ABS case with rubber overmold grip

P2000 Chrome-plated ABS case



PHV1433



P2125

ACCURACY

- Exceeds NIST traceable standards.

DURABILITY

- Super-tough ABS case with radial ribs for added strength.
- Patented Quad-Hook® long-life end hook on 1-inch blade-width models.
- Full-length clearcoat exceeds ASTM abrasion-resistance standards.
- Tapes exceed ASTM 96-hour salt spray test for corrosion resistance.

PERFORMANCE

- 9-Foot standout on 1-inch blade width models.
- Exclusive toggle blade-lock holds securely.

COMFORT and SELECTION

- Case designed to fit the hand.
- Easy thumb operation of toggle blade-lock.
- 360-Degree rubber overmold on P1000 tapes for non-slip grip.
- Full chrome case on P2000 tapes.
- Over 40 combinations of width, length, blade markings, and case style. (Call 888-222-8499 for size not listed below.)

	Catalog No.	Description	Case	Shelf Pack UPC Code	Case Quantity
	P2312	3/4" x 12'	Chrome	037103251817	6
	PQR1312	3/4" x 12' Quick Read	Hi-Viz Orange	037103251862	6
	PHV1316	3/4" x 16'	Hi-Viz Orange	037103251930	6
	PQR1316	3/4" x 16' Quick Read	Hi-Viz Orange	037103251947	6
	P2125	1" x 25'	Chrome	037103251954	6
	PHV1048DM	1" x 26' (25mm x 8m) Eng	Hi-Viz Orange	037103251992	6
	PHV1425	1" x 25'	Hi-Viz Orange	037103252005	4
	PHV1425D	1" x 25' Engineers	Hi-Viz Orange	037103252012	4
	P2133D	1" x 33' Engineers	Chrome	037103252043	6
	PHV1433	1" x 33'	Hi-Viz Orange	037103252081	6

Hand Tools

EXPERIENCE THE DIFFERENCE

Hand Tools - Tape Measures

3/8" x 50' Engineer's Anchor® Chrome Clad® Tape

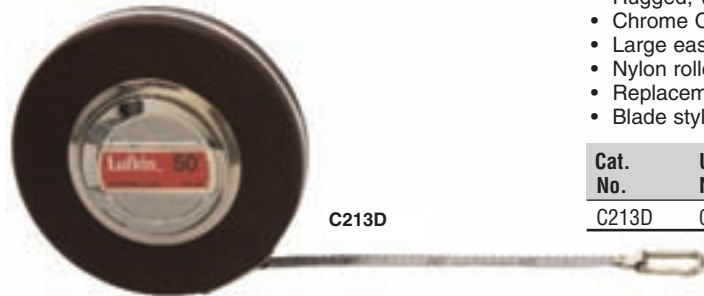

- Rugged, vinyl-covered steel case.
- Chrome Clad® blade.
- Large easy-action winding drum and friction washers.
- Nylon roller guides the tape smoothly in and out of case.
- Replacement blade: OC213D
- Blade style: B5

Cat. No.	UPC No.	Blade Size		Blade Style	Pack Wt.		Shelf Pack
		Width	Length		lbs.	kg	
C213D	037103451552	3/8"	50'	B5	0.93	0.42	1

3/8" x 50' Hi-Viz® Universal Lightweight Long Tape



- High impact polystyrene case, Hi-Viz® orange.
- Yellow clad blade .005"/0.13mm thick.
- Easy wind nylon drum.
- Easy-to-read black and red markings.
- Hook ring is retained neatly in the contoured mouth of the case.
- Removable belt clip.
- All tapes are carded.
- Replacement Blade: OY50
- Blade style: B1

Cat. No.	UPC No.	Blade Size		Blade Style	Pack Wt.		Shelf Pack
		Width	Length		lbs.	kg	
50	037103450685	3/8"	50'	B1	.50	.23	6

1/2" x 50' Hi-Viz® Orange Fiberglass Tape, Feet & Inches



- Open four-arm frame design protects blade, does not trap dirt in case.
- Lightweight but strong case is easy to handle and rewind.
- Two-material grip is comfortable to use.
- Hi-Viz® orange case is easy to find on the jobsite.
- Folding end hook for true-zero measurements.
- Feet and inches graduated to 8ths; numbered feet and instantaneous feet.
- Yellow clad fiberglass blade impervious to moisture.
- Replacement Blade: O703L
- Blade style: C1

Cat. No.	UPC No.	Blade Size		Blade Style	Pack Wt.		Shelf Pack
		Width	Length		lbs.	kg	
FE050	037103224033	1/2"	50'	C1	1.38	.63	6

1/2" x 100' / 1/2" x 300' Engineer's Hi-Viz® Orange Fiberglass Tapes, Feet & Inches



- Open four-arm frame design protects blade, does not trap dirt in case.
- Lightweight but strong case is easy to handle and rewind.
- Two-material grip is comfortable to use.
- Hi-Viz® orange case is easy to find on the jobsite.
- Folding end hook for true-zero measurements.
- Engineer's blade - 10ths and 100ths of feet plus feet.
- Yellow clad fiberglass blade impervious to moisture.
- Replacement Blade: FE100D - O706D, FE300D - O1709D
- Blade style: C2

Cat. No.	UPC No.	Blade Size		Blade Style	Pack Wt.		Shelf Pack
		Width	Length		lbs.	kg	
FE100D	037103224026	1/2"	100'	C2	1.65	.75	6
FE300D	037103224125	1/2"	300'	C2	3.0	1.36	2

Hand Tools - Levels, Plumb Bobs

HEAVY-DUTY 18V SELF-LEVELING CORDLESS INT/EXT ROTARY LASER KIT



Specifications:
 Power Supply9.6V-18V DEWALT Batteries
 Accuracy per 100 ft.....1/8 in.
 Rotation Speed.....0, 10, 60, 250, 800 rpm
 Self-Leveling Range±5 °
 Indoor Visibility Range200 (dia) ft.
 Range with Detector.....2000 (dia) ft.
 Laser Class.....IIIa (<5mW) @ 635nm
 Tool Weight6.5 lbs.
 Shipping Weight.....15 lbs.

- Includes
- 1-Hour charger.
 - 18V battery.
 - Digital laser detector.
 - Wall mount.
 - Wireless (IR) remote control.
 - Laser target card.
 - Laser enhancement glasses.
 - Heavy-duty kit box (w/padded interior).

Item# **DW079KD**

SELF LEVELING LEVEL, PLUMB AND SQUARE, 4-BEAM LASER



Specifications:
 Power Supply4 AA Alkaline
 Indoor Visibility Range100' ft.
 Laser ClassII (<1mW) @ 635nm

- Includes
- Kit box.

Item# **DW084K**

LASER PLUMB BOB



Specifications:
 Power Supply4 AA Alkaline
 Indoor Visibility Range100' ft.
 Laser ClassII (<1mW) @ 635nm

- Includes
- Kit box.

Item# **DW082K**

Brass Plumb Bobs



- Solid brass plumb bob with lacquered finish to resist corrosion.
- Ties easily to any string or line.
- Extra hardened steel tip included.

EMP912BR - 12 oz. Brass Plumb Bob
EMP90832 - Brass Plumb Bob Replacement Tip

Steel Plumb Bobs



- Steel plumb bob with plated finish to resist corrosion.
- Ties easily to any string or line.

EMP908 - 8 oz. Steel Plumb Bob

Hand Tools

Hand Tools - Squares, Straight Edges, Protractors



Combination Squares

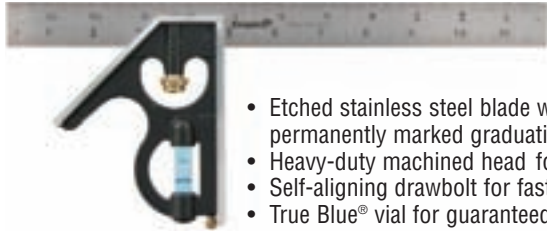

- Etched stainless steel blade with permanently marked graduations.
- Heavy-duty machined head for accuracy.
- Self-aligning drawbolt for fast blade changes.
- True Blue® vial for guaranteed leveling accuracy and durability. (EPMe250, EPMe255)



HEAVY-DUTY PROFESSIONAL COMBINATION SQUARE

Item# **EPMe250** 12" Blade (Stainless steel - will not rust)



POCKET COMBINATION SQUARE

Item# **EPMe255** 6" Blade (Stainless steel - will not rust)

12" COMBINATION SQUARES

Item# **EMP230** Machined square head, hardened scriber

Item# **EMP240** Metal square head, full view acrylic vial

Framing Squares

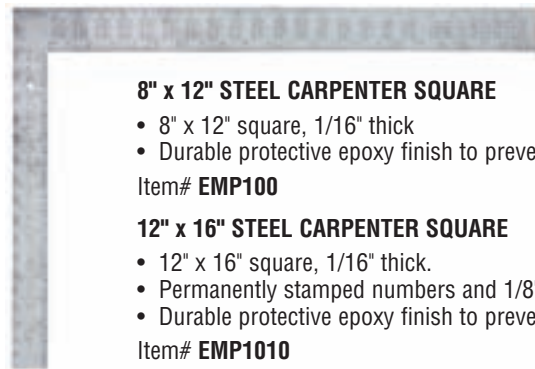

8" x 12" STEEL CARPENTER SQUARE

- 8" x 12" square, 1/16" thick
- Durable protective epoxy finish to prevent rust

Item# **EMP100**

12" x 16" STEEL CARPENTER SQUARE

- 12" x 16" square, 1/16" thick.
- Permanently stamped numbers and 1/8" graduations.
- Durable protective epoxy finish to prevent rust.

Item# **EMP1010**

16" x 24" STEEL TRADESMAN SQUARE

- 24" x 2" body, 16" x 1-1/2" tongue, 1/16" thick.
- Permanently stamped numbers and 1/8" graduations.
- Durable protective epoxy finish to prevent rust.

Item# **EMP1110**

16" x 24" ALUMINUM PROFESSIONAL SQUARE

- 24" x 2" body, 16" x 1-1/2" tongue, 1/8" thick.
- Permanently stamped numbers, rafter tables, graduations on brushed aluminum finish.
- Aluminum construction will not rust or corrode.
- Includes 1/8", 1/10", 1/16" stamped graduations.

Item# **EMP1140**

T-Square



PROFESSIONAL DRYWALL T-SQUARES

- Heavy-duty 3/16" thick blade, 47-7/8" long.
- Anodized aluminum finish.
- Large, bold numbers and graduations
- Patented rivet design. Permanently fixed joint of blade and head.

Item# **EMP418-48**

Protractor



MAGNETIC POLYCAST® PROTRACTOR

- Magnetic base and back.
- Easy reading dial with adjustable angle pointer.

Item# **EMP36**

Rafter Square



12" HEAVY-DUTY MAGNUM™ RAFTER SQUARE

- Solid aluminum extruded square will not bend or break.
- Stamped conversion tables.
- Mark or cut boards up to 12" wide.
- Thicker frame design ensures safe use as a saw guide.
- Graduated notches for "pulling" layout lines.
- Includes helpful instruction manual with complete rafter tables.

Item# **EMP3990**

Straight Edge



HEAVY-DUTY ALUMINUM STRAIGHT EDGES

- Easy reading inch scale graduations.
- Heavy-duty aluminum straight edge – 2" width.

Item# **EMP4003** 36"

Item# **EMP4006** 72"



Hand Tools - Levels

Heavy-Duty Box Beam Levels

- Thick-walled high-grade aluminum frame provides extreme durability and resists jobsite wear and tear.
- Continuous Edge increases level durability ensuring accuracy over time, protects center vial, and allows for continuous scribing.
- Plumb Site® offers dual-sided, undistorted viewing in the plumb position and easy, more accurate plumb readings.
- Over-molded rubber end caps provide shock-absorption, protecting the level's accuracy upon impact, and are removable for accurate leveling into corners.
- Rare earth magnets are 5X stronger than strip magnets and allow for easy, hands-free steel construction work (2550 Series).

2500 Series Heavy-Duty Box Beam Levels 2550 Series Magnetic Heavy-Duty Box Beam Levels

- | | |
|----------------------------|----------------------------|
| Item# 1794063 (24") | Item# 1794064 (24") |
| Item# 1794067 (48") | Item# 1794068 (48") |
| Item# 1794069 (72") | Item# 1794070 (72") |



Box Beam Levels

- Continuous Edge increases level durability ensuring accuracy over time, protects center vial, and allows for continuous scribing.
- Plumb Site® offers dual-sided, undistorted viewing in the plumb position and easy, more accurate plumb readings.
- Retractable end caps allow for scribing into and through corners, increasing work efficiency.
- Rare earth magnets are 5X stronger than strip magnets and allow for easy, hands-free steel construction work (2050 Series).

2000 Series Box Beam Levels 2050 Series Magnetic Box Beam Levels

- | | |
|----------------------------|----------------------------|
| Item# 1794075 (24") | Item# 1794076 (24") |
| Item# 1794077 (48") | Item# 1794078 (48") |
| Item# 1794079 (72") | Item# 1794080 (72") |



Heavy-Duty I-Beam Levels

- Dual Chamber Design increases level durability, ensuring accuracy over time, and resists twisting 2X more than traditional I-Beams.
- Plumb Site® offers dual-sided, undistorted viewing in the plumb position and easy, more accurate plumb readings.
- MagnaVials™ and wide top read window for easy, accurate readings.
- Rare earth magnets are 5X stronger than strip magnets and allow for easy hands-free steel construction work (1550 Series).

1500 Series Heavy-Duty I-Beam Levels 1550 Series Magnetic Heavy-Duty I-Beam Levels

- | | |
|----------------------------|----------------------------|
| Item# 1794105 (24") | Item# 1794106 (24") |
| Item# 1794107 (48") | Item# 1794108 (48") |
| Item# 1794109 (72") | Item# 1794110 (78") |



I-Beam Levels

- Rigid aluminum I-Beam construction.
- Rotating angle vial.
- Full length V-grooved strip magnet (1050 Series).

1000 Series I-Beam Levels 1050 Series Magnetic I-Beam Levels

- | | |
|----------------------------|----------------------------|
| Item# 1800990 (24") | Item# 1801091 (24") |
| Item# 1801094 (48") | Item# 1801095 (48") |
| Item# 1801096 (72") | Item# 1801097 (72") |



Magnetic Heavy-Duty Torpedo Level

- Die cast aluminum body provides extreme durability and strength.
- 1.5° Integrated button for easy 1/4" per foot drainage; button has a slight radius to ensure it sits securely on pipe.
- Plumb Site® offers dual-sided, undistorted viewing in the plumb position and easy, more accurate plumb readings.
- B-Tank valve key provides the ability to open an acetylene tank valve without stripping.
- Rare earth magnets are 5X stronger than strip magnets and allow for easy hands-free steel construction work.

250 Series Magnetic Torpedo Level

- Item# **1794153** (9")



Magnetic Torpedo Level

- Locking dial vial.
- Heavy-duty aluminum frame with composite body.
- V-groove edge for leveling pipe.

150 Series I-Beam Levels

- Item# **1794155** (9")



*Plumb Site® is a trademark of Kapro Industries, Ltd.

Hand Tools

EXPERIENCE THE DIFFERENCE

Hand Tools - Levels, Construction Line

Torpedo Levels



331-9 – 9" Magnetic Polycast® Torpedo Level



- Strong, accurate 9" Polycast® frame.
- Non-conductive frame insulates from heat, cold and electricity.
- Strong holding magnetic edge.
- Vials read plumb, level and 45°.

GOOD

581-9 – 9" Magnetic Torpedo Level



- Durable acrylic vials read plumb, level and 45°.
- Solid aluminum frame, 9" overall length.
- Magnetic edge frees hands.

BETTER

Also available:

- 587-36 - 9" Magnetic Torpedo Level
- 589-36 - Yellow Torpedo Level

em81.9 – 9" Heavy-Duty Magnetic Torpedo Level



- True Blue® vials are accurate to within 0.0005" per inch in all 10 level and plumb working positions.
- Heavy-duty extruded aluminum frame.
- Vials read plumb, level and 45°.
- Strong-holding magnetic edge.
- V-grooved working edge fits on pipe or conduit.
- Lifetime Warranty.



Utility Level

Line Level



- Lightweight construction minimizes line sag.
- Unbendable open hooks allow level to slide freely.
- Pocket clip will guard tool against loss.
- Vari-Pitch™ vial reads from level to 1/2" pitch in 1/8" increments.

83-3 - Standard Line Level

Construction Line

Twine



- Available in 250', 500' and 1000' rolls.
- Easy to see bright colors.

39613N - 250' Orange
39614N - 250' Pink

39713N - 500' Orange
39714N - 500' Pink

39813N - 1000' Orange
39814N - 1000' Pink

Abatix' online ordering system is simple to use. Once you are registered and have a customer code, you can create orders, customize shopping lists, and view ordering history, track shipments, view and print invoices and pay bills online. Head over to www.abatix.com and start shopping today.

Hand Tools - Marking

Standard Marking Chalk

- Interior or exterior use.
- Marks are temporary.
- Provides great visibility.



Item No.	Weight	Color
64901	8 oz.	Blue Chalk - Standard
64904	8 oz.	White Chalk - Standard
65101	5 lbs.	Blue Chalk - Standard
65104	5 lbs.	White Chalk - Standard

Hi-Visibility Marking Chalk

- Exterior use.
- Ideal for low light conditions and on dark surfaces.
- Use to show layout changes and corrections.



Item No.	Weight	Color
64903	8 oz.	Yellow Chalk - Hi-Vis
64905	8 oz.	Orange Chalk - Hi-Vis
64907	8 oz.	Green Chalk - Hi-Vis
65103	5 lbs.	Yellow Chalk - Hi-Vis
65105	5 lbs.	Orange Chalk - Hi-Vis
65106	5 lbs.	Green Chalk - Hi-Vis

Permanent Marking Chalk

- Exterior use.
- Visible after weeks of weather exposure and jobsite wear.



Item No.	Weight	Color
64902	8 oz.	Red Chalk - Permanent
64908	8 oz.	Black Chalk - Permanent
65102	5 lbs.	Red Chalk - Permanent



Professional Permanent Markers

- Marks on most surfaces, including wet and oily, abrasive, and nonporous surfaces.
- Oval-shaped barrel will not roll off flat surfaces.
- Stronger Professional chisel tip lasts 50% longer than standard Sharpie chisel tip on abrasive surfaces.
- AP Certified Nontoxic ink.



- 34801 Sharpie Professional - Black
- 34802 Sharpie Professional - Red



Large Capacity Chalk Reel

- Large capacity reservoir holds 14 oz. of chalk for minimum downtime.
- Steel crank, durable to last longer, handle locks to prevent line tangles.
- Nylon/polyester braided line, 2X increased durability, 150' of line – optimal for large jobs.
- 2:1 Gear Ratio, rewinds 2X faster for increased productivity.



Item No.	Description	Length
2031311	Large Capacity Chalk Reel	150'

Speed-Line Chalk Reel

- Retrieves chalk line 3.5X faster than a standard chalk reel.
- Crank handle clutch release allows release of the line without spinning the crank handle.
- Lightweight ABS impact-resistant case increases durability.
- Patented hook storage and door locking mechanism virtually eliminate spills and line tangles.
- Twisted polyester line holds more chalk for multiple line strikes.
- Holds approximately 2 oz. of chalk.



Item No.	Description	Length
64310	Fast Retrieve Chalk Reel - Carded	100'

Aluminum Chalk Reel

- Heavy-duty case is constructed of durable aluminum alloy.
- Steel plated hook and large grip anchor ring provide better holding power.
- Retractable self-locking metal handle allows reel to be used as a plumb bob.
- Twisted polyester line holds more chalk for multiple line strikes.
- Holds approximately 2 oz. of chalk.



Item No.	Description	Length
63950	Aluminum Chalk Reel - Carded	50'
64111	Aluminum Chalk Reel - Bulk	100'

Sharpie Magnum® Permanent Markers

- Industrial strength for big marking jobs.
- Marks on wet and oily surfaces.
- Oversized chisel tip draws extra wide, highly visible lines on corrugate, wood, metal, foil, stone, plastic, leather and more.
- Extra large ink supply.



- 44001SH Sharpie Magnum® Permanent Marker - Black

Hand Tools

EXPERIENCE THE DIFFERENCE

Hand Tools - Marking



Dixon Carpenter Pencils

Features:

Dixon's "Red and Black" carpenter pencil lays down a traditional rich black mark. It's easy to see, easy to sharpen, smooth marking and long lasting.

Item No.	Description
19973	7" Hard (Red and Black)
19972	7" Medium (Red and Black)



Dixon Redimark Permanent Marker - Metal Barrel

Features:

Excellent durability! Six-inch metal barrel permanent marker is leak-proof with a seamless metal body. Heavy-duty chisel felt-tip with anchored nib construction. Marks on wood, metal and more. Fast drying, fade resistant, permanent ink. AP certified non-toxic.

Item No.	Description
87170	Black



Dixon Lumber Crayons

Features:

Sets the standard for lumber crayons. These extruded lumber crayons last up to 10 times longer than ordinary molded wax crayons. Fade-proof, water-proof, smear-proof. Won't melt in direct sunlight. Will work on wet (green) lumber or dry wood, metal, concrete and most other surfaces. Each crayon is individually UPC coded. Hex shaped 4-1/2" x 1/2" to fit lumber crayon holders. One dozen per box.

Item No.	Description
49400	Carbon Black
49600	Yellow
52000	Red
52100	Blue
52200	Green
52300	White
52600	Fluorescent Pink



Dixon Walnut Handle Crayon Holder

Features:

High quality wood holder can accommodate both crayons and markers for increased convenience. It can hold product that is up to 1/2" in diameter and holds both round and hexagonal shapes. Walnut Crayon Holder has a metal chuck and a wrist strap hole for increased durability and functionality.

Item No.	Description
00500	Wooden Lumber Crayon Holder



Hand Tools - Utility Knives

ProTouch™ Retractable Knife

- Quick change mechanism allows for easy blade removal without opening the knife.
- Smooth, three-position slide provides increased durability for frequent use.
- Easy, tool-free entry with push button operation opens the knife and exposes replacement blades.
- Features inside storage for up to 5 blades.
- Includes 3 IRWIN BLUE BLADE™ Bi-Metal Utility Blades.

ProTouch™ Fixed Knife

- ProTouch™ ergonomic grip.
- Optimized cutting angle for reduced fatigue.
- Easy, tool-free entry.
- Features inside storage for up to 5 blades.
- Includes 6 IRWIN BLUE BLADE™ Bi-Metal Utility Blades.

Standard Safety Knife

- Self-retracting spring action returns blade safely into the housing when not in use.
- Interlocking nose reduces blade wobble.
- Ergonomic grip fits comfortably in the hand.
- Two blade positions – 2mm extension for box cutting and full extension for general use.
- Tool-free entry.

Bi-Metal BLUE BLADE™ Utility Blades

- Features patented Bi-Metal technology that sets new standards of performance.
- UNBREAKABLE: Spring steel body delivers superior flexibility to prevent breaking (under normal working conditions).
- LASTS LONGER: High speed steel cutting edge stays sharp longer than traditional carbon utility blades (tested on 20 lb. recycled paper).
- Fits most utility knives.

Item No. 2084400 - 100-Pack IRWIN BLUE BLADE™ Bi-Metal Utility Blades



Hand Tools - Hand Saws

20" ProTouch™ Course Cut Saw

- M2™ Tooth Technology: patent-pending advanced tooth geometry and Tri-Ground™ teeth provide a fast, efficient cut.
- Deep Gullets™ provide rapid removal of chips.
- Thick-Body™ Blade: delivers rigidity and control.
- Ergonomic ProTouch™ handle design – durability and comfort.
- Tapered-Pitch™ nose improves clearance and stability.



Item No.	Blade Length	Blade Thickness	Tooth Count
2011204	20" / 508mm	1mm	9 pt.

15" Standard Course Cut Saw

- M2™ Tooth Technology: patent-pending advanced tooth geometry and Tri-Ground™ teeth provide a fast, efficient cut.
- Deep Gullets™ provide rapid removal of chips.
- Easy-Start™ Front Teeth: 12pt. Extra-fine front teeth – rapid, smooth start.
- Thick-Body™ Blade: delivers rigidity and control.
- Tapered-Pitch™ nose improves clearance and stability.
- Hardwood handle.



Item No.	Blade Length	Blade Thickness	Tooth Count
2011102	15" / 381mm	1mm	9 pt.

Standard Drywall/Jaw Saw

- Rigid (1.2mm) blade.
- Bi-Ground teeth.
- Hardwood handle.



Item No.	Blade Length	Blade Thickness	Tooth Count
2014102	6-1/2" / 165mm	1.2mm	7 pt.

Hand Tools

EXPERIENCE THE DIFFERENCE

Hand Tools - Staple Guns

STANLEY® HEAVY-DUTY ALUMINUM STAPLE GUN



Features and Benefits

- Easy-squeeze handle reduces hand fatigue.
- Anti-jam mechanism saves time on the job.
- Yellow/Black color is easy to spot in a toolbox or workshop.
- Heavy-duty aircraft-aluminum housing for long-lasting, lightweight durability.
- Delivers high power and deep penetration.
- Bottom-loading, easy-slide, full-stick staple load.
- Uses Stanley® TRA700 Series or Arrow® T-50® heavy-duty staples.

Item# **STNTR150** Size: 5-1/4"H x 7"L Weight: 2.13 lbs.



STANLEY® HEAVY-DUTY CHROME-PLATED STEEL STAPLE GUN



Features and Benefits

- Perfect for everyday stapling needs around the home or office. Flush nose will fit flush against perpendicular surfaces such as the junction of a wall or ceiling.
- Heavy-duty, with convenient handle lock for safe storage.
- Quick-jam clear mechanism saves time and hassle.
- Chrome-plated steel construction for durability.
- Bottom-loading, easy-slide, full-stick staple load.

Item# **STNTR110**

Hand Tools - Staples

STANLEY® HEAVY-DUTY, NARROW CROWN STAPLES

Features and Benefits

- For heavy-duty stapling jobs such as insulation, carpet under laying and roofing felt.
- Color-coded packaging makes size and product selection easy.
- Sturdy plastic packaging reduces staple breakage.
- Heavy-Duty – 27/64" Narrow Crown Width – fits Stanley® TR100, TR200, TRE500 series, and Arrow® T-50®. PHT150C works with TRA704T, TRA705T, and TRA706T. PHT250C works with TRA705T, TRA706T, and TRA708T.

- Item# **STNTRA704T** 1/4" (6mm) (1,000/pack)
- Item# **STNTRA705T** 5/16" (8mm) (1,000/pack)
- Item# **STNTRA706T** 3/8" (10mm) (1,000/pack)
- Item# **STNTRA708T** 1/2" (12mm) (1,000/pack)
- Item# **STNTRA709T** 9/16" (14mm) (1,000/pack)



Looking for or considering a vending solution? With Abatix Supply Advantage Program – A.S.A.P. vending solutions you could reduce supply costs and improve productivity. Check out our web site to find out more about our A.S.A.P. vending solutions.

Hand Tools - Screwdrivers

Cushion-Grip Screwdrivers



Common Features:

- **Cushion-Grip** handle allows for greater torque and comfort.
- **Integral flanges** inside handle provide solid, twist-resistant blade anchor.
- **Special heat-treated shank.**
- **Precision-machined** tip for exact fit.
- **Premium chrome plated** for smooth feel and corrosion resistance.
- **Meets or exceeds** applicable ASME / ANSI specifications.
- **Patented Tip-Ident®** quickly identifies the type of screwdriver and screwdriver tip orientation.

Keystone-Tip Screwdrivers – Heavy-Duty Square-Shanks

- Heavy-duty square shank for wrench-assisted turning.
- Bolster reinforces shank for hard use.
- Designed for the most demanding uses.



600-4

Cat. No.	Shank Tip Width	Shank Length	Overall Length	Weight (lbs.)
600-4	1/4" (6mm)	4" (102mm)	8-11/32" (212mm)	.25
600-6	5/16" (8mm)	6" (152mm)	10-15/16" (278mm)	.40
600-8	3/8" (10mm)	8" (203mm)	13-7/16" (341mm)	.65
600-12	1/2" (13mm)	12" (305mm)	17-7/16" (443mm)	.80

Profilated Phillips-Tip Screwdrivers – Round-Shanks

- Tips are precision-machined to provide a more consistent geometric symmetry than conventional Phillips-tip screwdrivers.
- Provides accurate fit and torque without slippage.



603-7

Cat. No.	Point Size	Shank Length	Overall Length	Weight (lbs.)
603-1	No. 2	1-1/2" (38mm)	3-7/16" (87mm)	.10
603-3	No. 1	3" (76mm)	6-3/4" (171mm)	.15
603-4	No. 2	4" (102mm)	8-5/16" (211mm)	.25
603-6	No. 3	6" (152mm)	11" (279mm)	.35
603-7	No. 2	7" (178mm)	11-5/16" (287mm)	.30
603-10	No. 2	10" (254mm)	14-5/16" (364mm)	.35

7-Piece Cushion-Grip Screwdriver Set

- General-purpose selection of the most frequently used screwdrivers.
- Includes: three cabinet-tip, two Phillips-tip, two keystone-tip styles and plastic POP packaging.

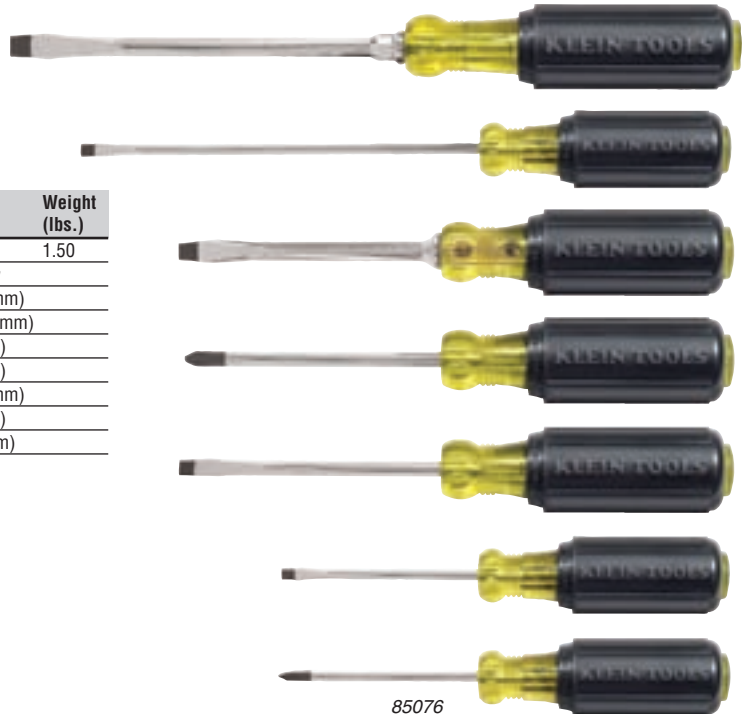

85076

Cat. No.	Set Contains	Weight (lbs.)	
85076		1.50	
Cat. No.	Description	Blade Length	Overall Length
600-4	square-shank, keystone-tip*	4" (102mm)	8-11/32" (212mm)
602-6	round-shank, keystone-tip*	6" (152mm)	10-15/16" (278mm)
601-3	round-shank, cabinet-tip	3" (76mm)	6-3/4" (171mm)
601-6	round-shank, cabinet-tip	6" (152mm)	9-3/4" (248mm)
605-4	round-shank, cabinet-tip*	4" (102mm)	8-11/32" (212mm)
603-3	round-shank, No. 1 Phillips-tip	3" (76mm)	6-3/4" (171mm)
603-4	round-shank, No. 2 Phillips-tip	4" (102mm)	8-5/16" (211mm)

*Heavy-duty models

Hand Tools

Hand Tools - Screwdrivers, Nut Drivers, Conduit Tools

4-In-1 Screwdriver

- Versatile screwdriver with interchangeable, snap-in blades.
- Tool supplied with four different tips on two reversible blades.

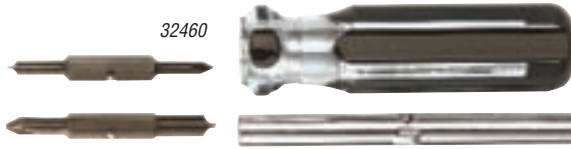

Cat. No.	Description	Overall Length	Weight (lbs.)
32460	screwdriver with two dual-tipped blades	7-5/8" (194mm)	.370

Six-in-One Tapping Tools

- Quickly forms new threads, re-forms burred threads and cleans out plaster obstructions.
- Each tap size rethreads to next larger size if threads are stripped.
- Two high-carbon steel taps are secured in reversible holder.



Cat. No.	Tap Sizes	Overall Length	Weight (lbs.)
627-20	6-32, 8-32, 10-32, 10-24, 12-24, 1/4-20	7-5/8" (194mm)	.35

Replacement Taps	
626-32	10-32, 8-32, 6-32
628-20	10-24, 12-24, 1/4-20

Triple Taps

- Quickly forms new threads, re-forms burred threads and cleans out plaster obstructions.
- Each tap size rethreads to next larger size if threads are stripped.



Cat. No.	Tap Sizes	Color Code	Overall Length	Weight (lbs.)
625-24	6-32, 8-32, 10-24	blue	7-1/8" (181mm)	.20
625-32	6-32, 8-32, 10-32	orange	7-1/8" (181mm)	.20

Replacement Taps	
626-24	for Cat. No. 625-24
626-32	for Cat. No. 625-32

Cushion-Grip Scratch Awl

- Professional, heavy-duty, hard-pointed awl.
- Scribes metal, starts screw holes, performs a variety of piercing and punching jobs.
- Rigid, chrome-plated, heat-treated, tempered-steel shank has full reinforcing bolster at handle for extra strength and for handle impact reinforcement.
- Internal flanges provide solid shank anchor.
- Cushion-Grip handle allows for greater comfort.



Cat. No.	Tap Sizes	Overall Length	Weight (lbs.)
650	3-1/2" (89mm)	7-7/8" (200mm)	.25



10-In-1 Screwdriver/Nut Driver

- End of handle is marked to quickly identify tool.



Cat. No.	Contains	Weight (lbs.)
32477	5/16" and 1/4" nut driver, #1 and #2 Phillips, 1/4" and 3/16" slotted, #10 and #15 TORX®, #1 and #2 square-recess	.35

Replacement Bits (each contain 2 bits)		
Cat. No.	Fits	Weight (lbs.)
32482	10-in-1 (Cat. No. 32477) #1 Phillips - 3/16" slotted	.010
32483	10-in-1 (Cat. No. 32477) #2 Phillips - 1/4" slotted	.012
32484	10-in-1 (Cat. No. 32477) #1 square - #2 square	.010
32485	10-in-1 (Cat. No. 32477) #10 Torx® - #15 Torx®	.008

TORX® is a registered trademark of Acument Intellectual Properties, LLC.

Conduit-Fitting Screwdriver

- Hooded blade design keeps tip from slipping out of screws, especially when tightening hard-to-reach screws like those in conduit fittings.



Cat. No.	Shank Tip Width	Shank Length	Overall Length	Weight (lbs.)
19360	3/8" (9.5mm)	1" (25mm)	5-11/32" (153mm)	.24

Conduit Reamer

- Locks onto screwdrivers; reams and smooths thin-wall conduit.
- Reams ID and OD at the same time.
- Two set-screws to fit round- or square-shank screwdrivers.
- Fits up to 3/8" (10mm) keystone-tip screwdrivers.
- NOT for use on power tools.



Cat. No.	Conduit Capacity	Weight (lbs.)
19352	1/2", 3/4", 1"	.16
19351	replacement blade for 19352	.01

Conduit-Fitting and Reaming Screwdriver

- Hooded-blade design keeps tip from slipping out of screws, especially when tightening hard-to-reach conduit fittings. Thicker hood is designed for rugged use.
- Reams and smooths 1/2" (13mm), 3/4" (19mm) and 1" (25mm) thin-wall conduit ends to protect wire and permit correct installation of fittings.
- Reams both the inside and outside of the conduit at the same time.
- Longer Cushion-Grip handle provides comfort and more torque for reaming.
- Replaceable reaming blade is held in place with a 1/16" hex socket set screw.



Cat. No.	Shank Tip Width	Shank Length	Overall Length	Weight (lbs.)
85191	3/8" (10mm)	2-1/2" (64mm)	7-1/2" (191mm)	.55
19353	conduit reamer replacement blade kit			.01

Hand Tools - Nut Drivers, Stripper/Cutters



Cushion-Grip Nut Drivers

Common Features:

- **Cushion-Grip** handle allows for greater torque and comfort.
- **Internal flanges** provide solid, twist-resistant shaft anchor.
- **Patented Tip-Ident**® quickly identifies nut driver and size.
- **Handle ends are color coded** for easy identification.

- **Full hollow shafts** facilitate work on stacked circuit boards or other long bolt applications.
- **Premium chrome plated** for smooth feel and corrosion resistance.
- **Meets or exceeds** applicable ASME / ANSI specifications.

Cushion-Grip Hollow-Shaft Nut Drivers – 3" Shafts

- Standard length for most applications.
- Fits over long bolts and studs.



630-1/2

Cat. No.	Color Code	Hex Size	Shaft Length	Overall Length	Weight (lbs.)
630-3/16	black	3/16"	3" (76mm)	6-3/4" (171mm)	.20
630-1/4	red	1/4"	3" (76mm)	6-3/4" (171mm)	.20
630-5/16	yellow	5/16"	3" (76mm)	6-3/4" (171mm)	.20
630-11/32	green	11/32"	3" (76mm)	6-3/4" (171mm)	.20
630-3/8	blue	3/8"	3" (76mm)	6-3/4" (171mm)	.20
630-7/16	brown	7/16"	3" (76mm)	7-5/16" (186mm)	.25
630-1/2	red	1/2"	3" (76mm)	7-5/16" (186mm)	.25
630-9/16	orange	9/16"	4" (102mm)	9-3/8" (238mm)	.35
630-5/8	yellow	5/8"	4" (102mm)	9-3/8" (238mm)	.35

7-Piece Cushion-Grip Nut Driver Set – 3" Shafts

- General-purpose selection of the most frequently used nut drivers.
- Fits over long bolts and studs.



631

Cat. No.	Set Contains	Weight (lbs.)
631	Set Contains: 630-3/16, 630-1/4, 630-5/16, 630-11/32, 630-3/8, 630-7/16 and 630-1/2.	1.50

Wire Stripper/Cutters

Multi-Purpose 6-in-1 Tool

- Cleanly shears bolts / Easily cuts and strips wire.
- Measures stud sizes / Gauges wire sizes.
- Crimps insulated terminals.
- Plastic-covered cushioned handles for comfort.

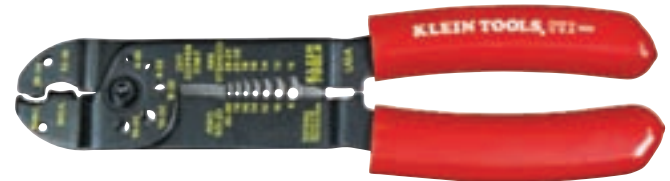

Cat. No.	Overall Length	Strips and Cuts	Bolt Sizes	Handle Color	Weight (lbs.)
1000	7-3/4" (197mm)	10 – 22 AWG (4.0mm ² – .34mm ²)	4-40, 6-32, 8-32, 10-24, 10-32	red	.44

Wire Stripper/Cutters

- Compact, lightweight wire-stripping and cutting tool.
- Narrow nose fits into tight places.
- Hardened steel with precision ground stripping holes.
- Do not use for cutting steel wire or bolts.
- Spring-loaded action for self-opening.
- Precision-ground stripping holes for easy removal of insulation.
- Easy-to-read wire gauge markings on both sides for stripping in either direction.
- Black-oxide finish resists corrosion.
- Color-coded handles: yellow indicates solid wire.
- Textured handles provide a firm, comfortable grip.
- Wire looping and bending holes.

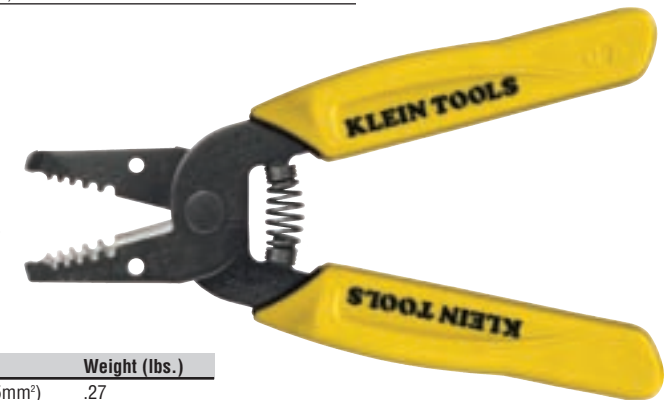

Cat. No.	Handle Color	Overall Length	Strips and Cuts	Weight (lbs.)
11045	yellow	6-1/4" (159mm)	10 – 18 AWG solid (4.0mm ² – .75mm ²)	.27

Wire Stripper/Cutters

- Precision shear-type blades for clean cuts on stranded copper wire.
- Double dipped comfort grips and curved handles.
- Strips, cuts and gauges 6-12 AWG stranded wire.
- Hardened steel with precision ground stripping holes.
- Strong-gripping serrated nose for easy bending, shaping and pulling of wire.
- Screw-shearing holes / Holes for looping and bending wire.
- Coil spring provides fast self-opening action / Handy closure lock for convenient storage.
- Black-oxide finish resists corrosion.

KLEIN-KURVE™



Cat. No.	Handle Color	Overall Length	Strips and Cuts	Screw Shearing	Weight (lbs.)
11053	blue/red	7-1/8" (181mm)	6 – 12 AWG stranded (10mm ² – 2.5mm ²)	6-32 and 8-32	.34

Hand Tools

EXPERIENCE THE DIFFERENCE

Hand Tools - Pliers

**IRWIN.
VISE-GRIP**

GrooveLock Pliers

- Press and slide button quickly adjusts lower jaw.
- All purpose jaw grips on round, flat, square and hex shapes.
- Multi-groove ratcheting system has twice the groove positions that other groove joint pliers, for precise positioning on any type of work surface.
- Anti-pinch, non-slip ProTouch grips provide comfort, control and less hand fatigue.
- Anti-pinch design prevents handles from pinching.



Item No.	Description	Size	Jaw Capacity	Groove Positions	Pipe Size	Nut Size (across flats)
2078108	8" GrooveLock	8" / 200mm	1-3/4"	13	1"	30mm (1.18")
2078110	10" GrooveLock	10" / 250mm	2-1/4"	16	1-1/2"	40mm (1.57")
2078112	12" GrooveLock	12" / 300mm	2-3/4"	19	2"	50mm (1.96")

The Original™ Straight Jaw Locking Pliers

- Straight jaws provide maximum contact on flat, square or hex work.
- Ideal for tightening, clamping, twisting and turning.
- Turn screw to adjust pressure and fit work. Stays adjusted for repetitive use.
- Constructed of high-grade, heat-treated alloy steel for maximum toughness and durability.
- Guarded release trigger quickly unlocks and protects from accidental release.
- Hardened teeth are designed to grip from any angle.



Item No.	Description	Size	Jaw Capacity
0102L3	10R	10" / 250mm	1-3/4" / 44mm
0302L3	7R	7" / 175mm	1-5/16" / 33mm

The Original™ Curved Jaw Locking Pliers with Wire Cutter

- Curved jaw puts tremendous pressure on four points of any style nut or bolt head; includes convenient wire cutter.
- Ideal for tightening, clamping, twisting and turning.
- Turn screw to adjust pressure and fit work. Stays adjusted for repetitive use.
- Constructed of high-grade, heat-treated alloy steel for maximum toughness and durability.
- Guarded release trigger quickly unlocks and protects from accidental release.
- Hardened teeth are designed to grip from any angle.



Item No.	Description	Size	Jaw Capacity
0502L3	10WR	10" / 250mm	1-7/8" / 48mm
0702L3	7WR	7" / 175mm	1-1/2" / 38mm

Fast Release™ Curved Jaw Locking Pliers

- Fast Release™ is 2x easier to open and has a no-pinch release.
- Curved jaw puts tremendous pressure on four points of any style nut or bolt head. The no-slip ProTouch™ grip provides comfort and leverage while reducing vibrations and hand fatigue.
- Ideal for tightening, clamping, twisting and turning.
- Turn screw to adjust pressure and fit work. Stays adjusted for repetitive use.
- Constructed of high-grade, heat-treated alloy steel for maximum toughness and durability.
- Hardened teeth are designed to grip from any angle.



Item No.	Description	Size	Jaw Capacity
11T	10CR	10" / 250mm	1-7/8" / 48mm

Hand Tools - Pliers



Long Nose Plier with Side Cutter

- Cross-hatching on jaws grabs work tightly.
- Precision made of fine polished, high carbon drop forged steel.
- Perfectly mated cutters, scientifically heat treated to hold their edge.
- Distinctive CHANNELLOCK BLUE® comfort grips.

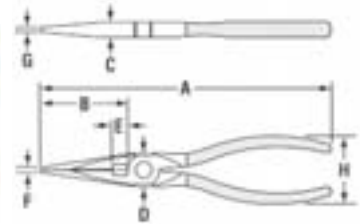
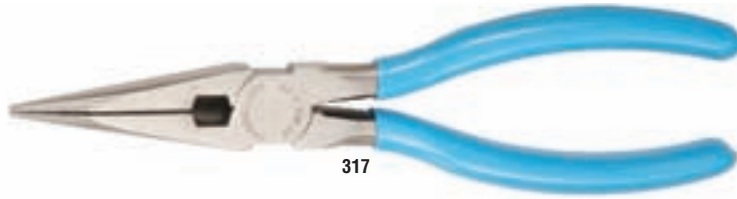

PLIER	A OVERALL LENGTH		B JAW LENGTH		C JOINT THICKNESS		D JOINT WIDTH		E CUTTING EDGE		F NOSE WIDTH		G NOSE THICKNESS		H HANDLE SPAN		WEIGHT	
	in.	mm	in.	mm	in.	mm	in.	mm	in.	mm	in.	mm	in.	mm	in.	mm	lbs.	grams
317	8.00	203.20	2.36	59.94	0.41	10.41	0.87	22.10	0.41	10.41	0.14	3.56	0.11	2.79	1.89	48.01	0.55	249.48

Linemen's Plier – WIREMASTER™

- WIREMASTER™, premium quality linemen's plier.
- Heavy-duty construction.
- Perfectly mated cutters, scientifically heat treated to hold its edge.
- Round nose design.
- Enclosed-joint design holds cutters in perfect alignment for the life of the plier.
- Special high leverage handle design.
- Precision made of fine polished high carbon drop forged steel.
- CHANNELLOCK BLUE® comfort grip.
- Cuts ACSR.

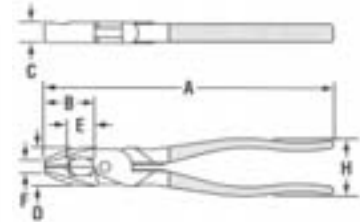

PLIER	A OVERALL LENGTH		B JAW LENGTH		C JOINT THICKNESS		D JOINT WIDTH		E CUTTING EDGE		F NOSE WIDTH		H HANDLE SPAN		WEIGHT	
	in.	mm	in.	mm	in.	mm	in.	mm	in.	mm	in.	mm	in.	mm	lbs.	grams
349	9.25	234.95	1.59	40.39	0.63	16.00	1.26	32.00	0.81	20.57	0.40	10.16	1.89	48.01	1.02	462.66

Ironworkers Plier with Coiled Spring

- Heavy-duty design, precision made of fine polished high carbon drop forged steel.
- Perfectly mated cutters, heat treated to hold its edge.
- Coiled spring for positive jaw opening.
- Special cross hatched tooth design.
- CHANNELLOCK BLUE® comfort grips.
- Cuts ACSR.

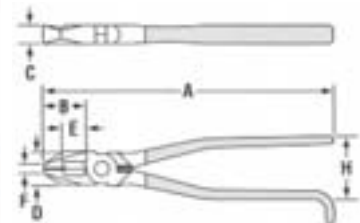
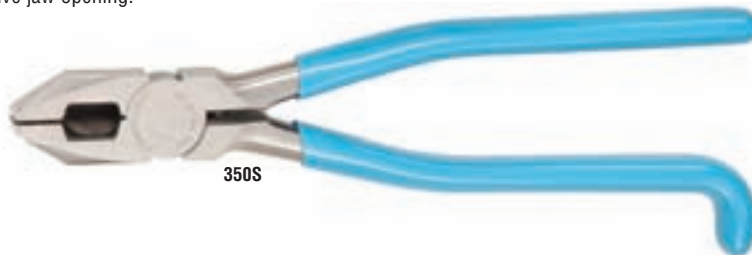

PLIER	A OVERALL LENGTH		B JAW LENGTH		C JOINT THICKNESS		D JOINT WIDTH		E CUTTING EDGE		F NOSE WIDTH		H HANDLE SPAN		WEIGHT	
	in.	mm	in.	mm	in.	mm	in.	mm	in.	mm	in.	mm	in.	mm	lbs.	grams
350S	8.75	222.25	1.28	32.51	0.53	13.46	1.06	26.92	0.66	16.76	0.28	7.11	1.89	48.01	0.81	367.41

CHANNELLOCK BLUE® comfort grips are only for hand comfort and improved appearance. They are NOT recommended or warranted for dielectric properties.

Hand Tools

EXPERIENCE THE DIFFERENCE

Hand Tools - Pliers

Linemen's Plier – High Leverage

- High leverage design.
- Perfectly mated cutter, heat treated to hold its edge.
- Polished high carbon drop forged steel.
- Cuts ACSR.
- Useful crushing area.
- CHANNELLOCK BLUE® comfort grips.

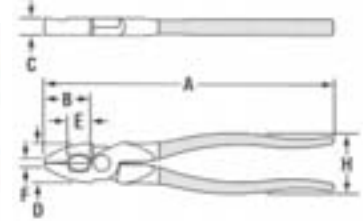

PLIER	A OVERALL LENGTH		B JAW LENGTH		C JOINT THICKNESS		D JOINT WIDTH		E CUTTING EDGE		F NOSE WIDTH		H HANDLE SPAN		WEIGHT	
	in.	mm	in.	mm	in.	mm	in.	mm	in.	mm	in.	mm	in.	mm	lbs.	grams
369	9.50	241.30	1.54	39.12	0.55	13.97	1.32	33.53	0.73	18.54	0.28	7.11	1.89	48.01	1.08	489.88

Smooth Jaw Tongue and Groove Plier

- Smooth jaw for use on plated fixtures, PVC pipe, chromes, etc.
- Patented undercut tongue and groove design assures no slip jaw action.
- Patented reinforcing edge minimizes stress breakage.
- Patented PermaLock® fastener eliminates nut and bolt failures.
- Distinctive CHANNELLOCK BLUE® comfort grips.

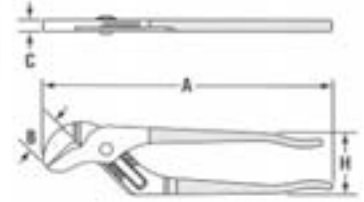

PLIER	A OVERALL LENGTH		B JAW LENGTH		C JOINT THICKNESS		H HANDLE SPAN		WEIGHT		NUMBER OF ADJUSTMENTS	JAW CAPACITY	
	in.	mm	in.	mm	in.	mm	in.	mm	lbs.	grams		in.	mm
415	10.00	254.00	1.38	35.05	0.44	11.18	2.13	54.10	0.98	444.52	7	2.00	50.80

Tongue and Groove Pliers

- Right angle teeth grip in all directions for maximum bite and minimum wear.
- Patented undercut tongue and groove design assures no slip jaw action.
- Patented reinforcing edge minimizes stress breakage.
- Patented PermaLock® fastener eliminates nut and bolt failures.
- Distinctive CHANNELLOCK BLUE® comfort grips.

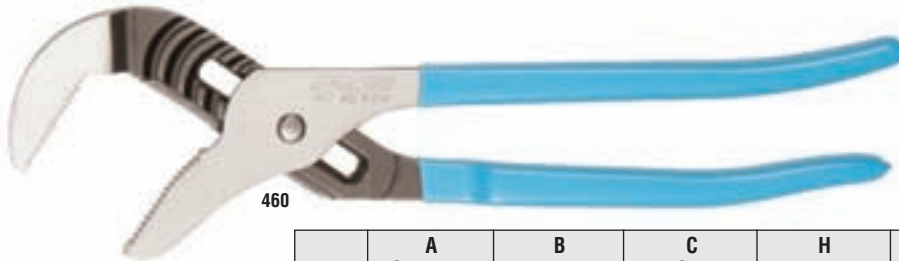

PLIER	A OVERALL LENGTH		B JAW LENGTH		C JOINT THICKNESS		H HANDLE SPAN		WEIGHT		NUMBER OF ADJUSTMENTS	JAW CAPACITY	
	in.	mm	in.	mm	in.	mm	in.	mm	lbs.	grams		in.	mm
460	16.50	419.10	2.56	65.02	0.59	14.99	1.93	49.02	3.14	1424.28	8	4.25	107.95
440®	12.00	304.80	1.50	38.10	0.50	12.70	1.81	45.97	1.64	743.89	7	2.25	57.15
430®	10.00	254.00	1.38	35.05	0.44	11.18	2.13	54.10	1.18	535.24	7	2.00	50.80
420®	9.50	241.30	1.12	28.45	0.47	11.94	1.57	39.88	0.87	394.63	5	1.50	38.10
426	6.50	165.10	0.81	20.57	0.47	11.94	1.69	42.93	0.37	167.83	5	0.87	22.10

CHANNELLOCK BLUE® comfort grips are only for hand comfort and improved appearance. They are NOT recommended or warranted for dielectric properties.

Hand Tools - Pliers



V-Jaw Tongue and Groove Pliers

- V-jaws give you more points of contact on round stock and tubing.
- Right angle teeth grip in all directions for maximum bite and minimum wear.
- Patented undercut tongue and groove design assures no slip jaw action.
- Patented reinforcing edge minimizes stress breakage.
- Patented PermaLock® fastener eliminates nut and bolt failures.
- Distinctive CHANNELLOCK BLUE® comfort grips.

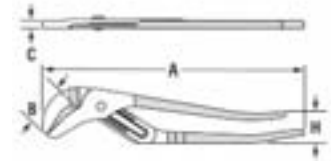

442

PLIER	A OVERALL LENGTH		B JAW LENGTH		C JOINT THICKNESS		H HANDLE SPAN		WEIGHT		NUMBER OF ADJUSTMENTS	JAW CAPACITY	
	in.	mm	in.	mm	in.	mm	in.	mm	lbs.	grams		in.	mm
442	12.00	304.80	1.50	38.10	0.50	12.70	1.69	42.93	1.78	807.39	7	2.25	57.15
422	9.50	241.30	1.12	28.45	0.47	11.94	1.57	39.88	0.84	381.02	5	1.50	38.10

BigAzz® Tongue and Groove Plier

- Big as the job. Big as you need.
- Right angle teeth grip in all directions for maximum bite and minimum wear.
- Patented undercut tongue and groove design assures no slip jaw action.
- Patented reinforcing edge minimizes stress breakage.
- Patented PermaLock® fastener eliminates nut and bolt failures.
- Distinctive CHANNELLOCK BLUE® comfort grips.



480

PLIER	A OVERALL LENGTH		B JAW LENGTH		C JOINT THICKNESS		H HANDLE SPAN		WEIGHT		NUMBER OF ADJUSTMENTS	JAW CAPACITY	
	in.	mm	in.	mm	in.	mm	in.	mm	lbs.	grams		in.	mm
480	20.25	514.35	3.00	76.20	0.59	14.99	3.31	84.07	3.81	1728.19	12	5.50	139.70

The Locknut Plier

- Designed for quick and easy adjustment of electrical locknuts.
- Fits: 1/2", 3/4", 1", 1-1/4" and 1-1/2" locknuts.
- Securely holds and adjusts to most conduit fitting locknuts made of metal, PVC or plastic.
- Thin profile – for use in tight/wire confined electrical boxes.
- Handle shape allows both right-handed and left-handed use of the tool.
- Spring loaded handles.
- Handle lock for ease of storage.
- Made in U.S.A.

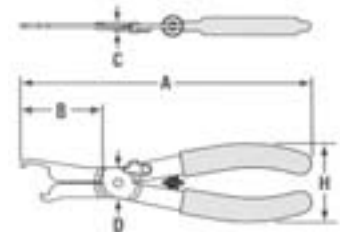

960

PLIER	A OVERALL LENGTH		B JAW LENGTH		C JOINT THICKNESS		D JOINT WIDTH		E CUTTING EDGE		H HANDLE SPAN		WEIGHT	
	in.	mm	in.	mm	in.	mm	in.	mm	in.	mm	in.	mm	lbs.	grams
960	8.50	215.90	2.38	60.45	0.21	5.33	0.92	23.37	N/A	N/A	2.54	64.52	0.48	217.72

CHANNELLOCK BLUE® comfort grips are only for hand comfort and improved appearance. They are NOT recommended or warranted for dielectric properties.

Hand Tools

EXPERIENCE THE DIFFERENCE

Hand Tools - Pliers



Side-Cutting Pliers

9" High-Leverage Side-Cutting Pliers – Heavy-Duty Cutting 2000 Series®

- Cuts ACSR, screws, nails and most hardened wire.
- High-leverage design. Rivet is closer to the cutting edge for 46% greater cutting and gripping power than other plier designs.
- Streamlined design with sure-gripping, cross-hatched knurled jaws.
- 2000 Series - Heavy-duty cutting knives. Cuts ACSR, screws, nails and most hardened wire. Features combination polished and black-oxide finish.



Cat. No.	Nose Type	Overall Length	Jaw Length	Jaw Width	Jaw Thickness	Knife Length	Handle Finish	Handle Color	Weight (lbs.)
D2000-9NE	New England	9-3/8" (238mm)	1-19/32" (41mm)	1-1/4" (32mm)	5/8" (16mm)	25/32" (20mm)	plastic-dipped	royal blue	1.09

9" High-Leverage Side-Cutting Pliers

- High-leverage design. Rivet is closer to the cutting edge for 46% greater cutting and gripping power than other plier designs.
- Streamlined design with sure-gripping, cross-hatched knurled jaws.



Cat. No.	Nose Type	Overall Length	Jaw Length	Jaw Width	Jaw Thickness	Knife Length	Handle Finish	Handle Color	Weight (lbs.)
D213-9NE	New England	9-3/8" (238mm)	1-19/32" (41mm)	1-1/4" (32mm)	5/8" (16mm)	25/32" (20mm)	plastic-dipped	dark blue	1.14

Side-Cutting Pliers

- Sure-gripping, cross-hatched knurled jaws.



Cat. No.	Nose Type	Overall Length	Jaw Length	Jaw Width	Jaw Thickness	Knife Length	Handle Finish	Handle Color	Weight (lbs.)
Streamlined Design									
D201-7NE	New England	7-7/16" (189mm)	1-9/32" (33mm)	1-1/16" (27mm)	1/2" (13mm)	5/8" (16mm)	plastic-dipped	dark blue	.55
Square Nose									
D201-8	Square	8-11/16" (221mm)	1-7/16" (37mm)	1-7/32" (31mm)	5/8" (16mm)	23/32" (18mm)	plastic-dipped	dark blue	.93

9" Ironworker's Work Pliers – High-Leverage

- Twists and cuts soft annealed rebar tie wire.
- High-leverage design. Rivet is closer to the cutting edge for 46% greater cutting and gripping power than other plier designs.
- Hook bend handle.
- Spring-loaded action for self-opening.
- Heavy-duty knurled jaws.



D213-9ST

Cat. No.	Nose Type	Overall Length	Jaw Length	Jaw Width	Jaw Thickness	Knife Length	Handle Finish	Handle Color	Weight (lbs.)
213-9ST	Square	9-1/4" (235mm)	1-19/32" (41mm)	1-1/4" (32mm)	5/8" (16mm)	25/32" (20mm)	plain	n/a	1.02
D213-9ST	Square	9-3/8" (238mm)	1-19/32" (41mm)	1-1/4" (32mm)	5/8" (16mm)	25/32" (20mm)	plastic-dipped	dark blue	1.10
2000 Series® – Heavy-duty cutting knives									
D2000-9ST	Square	9-3/8" (238mm)	1-19/32" (41mm)	1-1/4" (32mm)	5/8" (16mm)	25/32" (20mm)	plastic-dipped	royal blue	1.10

*Cuts ACSR, screws, nails and most hardened wire. Features combination polished and black-oxide finish.

Ironworker's Work Pliers

- Twists and cuts soft annealed rebar tie wire.
- Hook bend handle.
- Spring-loaded action for self-opening.
- Heavy-duty knurled jaws.



D201-7CST

Cat. No.	Nose Type	Overall Length	Jaw Length	Jaw Width	Jaw Thickness	Knife Length	Handle Finish	Handle Color	Weight (lbs.)
D201-7CST	Square	9-1/4" (235mm)	1-9/32" (33mm)	1-5/32" (29mm)	1/2" (13mm)	5/8" (16mm)	plastic-dipped	dark blue	.63

Hand Tools - Pliers

Diagonal-Cutting Pliers



8" High-Leverage Diagonal-Cutting Pliers

- High-leverage design. Rivet is closer to the cutting edge for 36% greater cutting power than other plier designs.
- Hot-riveted joint ensures smooth action and no handle wobble.
- Induction hardened cutting knives for long life.
- Short jaws and beveled cutting edges permit close cutting of wire.



D228-8

Cat. No.	Overall Length	Jaw Length	Jaw Width	Jaw Thickness	Cutting Knives	Handle Finish	Handle Color	Weight (lbs.)
D228-8	8-1/16" (205mm)	13/16" (21mm)	1-3/16" (30mm)	7/16" (11mm)	standard	plastic-dipped	red	.60

8" High-Leverage Diagonal-Cutting Pliers – Angled Head

- Angled head design for easy work in confined spaces.
- High-leverage design. Rivet is closer to the cutting edge for 36% greater cutting power than other plier designs.



D248-8

Cat. No.	Overall Length	Jaw Length	Jaw Width	Jaw Thickness	Cutting Knives	Handle Finish	Handle Color	Weight (lbs.)
D248-8	8-1/16" (205mm)	13/16" (21mm)	1-3/16" (30mm)	7/16" (11mm)	standard	plastic-dipped	red	.60

9" High-Leverage Diagonal-Cutting Pliers

- Angled head design for easy work in confined spaces.
- Hooked handle for improved grip.
- High-leverage design. Rivet is closer to the cutting edge for 36% greater cutting power than other plier designs.



D248-9ST

Cat. No.	Overall Length	Jaw Length	Jaw Width	Jaw Thickness	Cutting Knives	Handle Finish	Handle Color	Weight (lbs.)
D248-9ST	9-3/16" (233mm)	13/16" (21mm)	1-3/16" (30mm)	7/16" (11mm)	standard	plastic-dipped	red	.68

Long-Nose Pliers

Common Features:

- Custom, US-made tool steel.
- Hot-riveted joint ensures smooth action and no handle wobble.
- Slim head design for working in confined areas.
- Plastic-dipped handles for comfort and ease of identification.

8" Heavy-Duty Long-Nose Pliers – Side-Cutting

- Induction hardened cutting knives for long life.
- Heavier design for greater cutting power.
- Extended handles provide added reach and leverage.

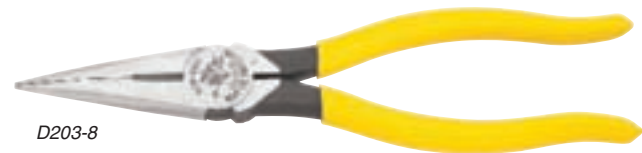

D203-8

Cat. No.	Overall Length	Jaw Length	Jaw Width	Jaw Thickness	Knife Length	Point Thickness	Handle Finish	Handle Color	Weight (lbs.)
D203-8	8-7/16" (214mm)	2-5/16" (59mm)	1" (25mm)	1/2" (13mm)	5/8" (16mm)	1/8" (3mm)	plastic-dipped	yellow	.60
Wire Stripping – Cleanly strips 12 AWG wire									
D203-8N	8-7/16" (214mm)	2-5/16" (59mm)	1" (25mm)	1/2" (13mm)	5/8" (16mm)	1/8" (3mm)	plastic-dipped	yellow	.59

Standard Long-Nose Pliers – Side-Cutting

- Induction hardened, long-lasting cutting knives.
- Knurled jaws for sure wrapping and looping.
- Curved handles provide greater tool control.

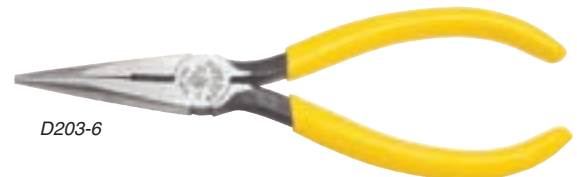

D203-6

Cat. No.	Overall Length	Jaw Length	Jaw Width	Jaw Thickness	Knife Length	Point Thickness	Handle Finish	Handle Color	Weight (lbs.)
D203-6	6-5/8" (168mm)	1-7/8" (48mm)	11/16" (18mm)	3/8" (10mm)	1/2" (13mm)	3/32" (2mm)	plastic-dipped	yellow	.27
D203-7	7-3/16" (183mm)	2-7/16" (62mm)	11/16" (18mm)	3/8" (10mm)	1/2" (13mm)	3/32" (2mm)	plastic-dipped	yellow	.29

Hand Tools

EXPERIENCE THE DIFFERENCE

Hand Tools - Locking Tools



Fast Release™ Long Nose Locking Pliers

- Fast Release™ is 2x easier to open and has a no-pinch release.
- The no-slip ProTouch™ grip provides comfort and leverage while reducing vibrations and hand fatigue.
- Ideal for tightening, clamping, twisting and turning.
- Turn screw to adjust pressure and fit work. Stays adjusted for repetitive use.
- Constructed of high-grade, heat-treated alloy steel for maximum toughness and durability.
- Hardened teeth are designed to grip from any angle.



Item No.	Description	Size	Jaw Capacity
15T	9LN	9" / 225mm	4-1/2" / 112mm

Fast Release™ Locking C-Clamps with Regular Tips

- Fast Release™ is 2x easier to open and has a no-pinch release.
- Wide-opening jaws provide greater versatility in clamping a variety of shapes.
- Turn screw to adjust pressure and fit work. Stays adjusted for repetitive use.
- Constructed of high-grade, heat-treated alloy steel for maximum toughness and durability.



Item No.	Description	Size	Jaw Capacity
19T	11R	11" / 275mm	3-3/8" / 85mm

The Original™ Locking Welding Clamp

- U-shaped jaws provide enhanced visibility and more working space.
- Holds work in proper alignment.
- For use in welding applications or for holding awkward shapes in place.
- Turn screw to adjust pressure and fit work. Stays adjusted for repetitive use.
- Constructed of high-grade, heat-treated alloy steel for maximum toughness and durability.
- Guarded release trigger quickly unlocks and protects from accidental release.



Item No.	Description	Size	Throat Depth	Jaw Capacity	Jaw Depth
25ZR	9R	9" / 225mm	1-58" / 41mm	2-3/4" / 70mm	2-3/4" / 70mm

Aviation Snips – Offset / Utility / Tinner

- Hot drop forged steel blades for a sharper cutting edge and greater strength.
- The ergonomically designed ProTouch™ grips and long-life spring increase the leverage and optimize each cut.
- Equipped with multiple pivot pins that provide compound cutting action.



Model	Description	Size	Length of Cut	Cutting Capacity		Carded Stock No.
111	Cuts left and straight	10" / 254mm	1-5/16" / 33mm	Cold-Roll Steel, 18 ga.	Stainless Steel, 23 ga.	2073111
112	Cuts right and straight	10" / 254mm	1-5/16" / 33mm	Cold-Roll Steel, 18 ga.	Stainless Steel, 23 ga.	2073112
113	Cuts straight and wide curves	10" / 254mm	1-5/16" / 33mm	Cold-Roll Steel, 18 ga.	Stainless Steel, 23 ga.	2073113
115	Bulldog snips notch and trim	9" / 228mm	3/4" / 19mm	Cold-Roll Steel, 16 ga.	Stainless Steel, 18 ga.	2073115

Hand Tools - Cutting Tools

Cable Cutters



High-Leverage Cable Cutters

- High-leverage design for exceptional cutting capability.
- Precision, one-hand shearing action.
- Cable-gripping shear-type jaws.
- Perfect for working in confined spaces.
- Can be carried in most tool pouches.
- Hot-riveted joint ensures smooth action and no handle wobble.
- Beveled jaw tips provide proper mating and shearing action, which protects leading jaw edges.
- Through-hardened (not case-hardened) for longer-lasting cutting surfaces.
- Custom, US-made tool steel.



63050

Cat. No.	Overall Length	Handle Color	Maximum Cable Cutting Capacity	Weight (lbs.)
63050	9-1/2" (241mm)	red	4/0 aluminum, 2/0 soft copper, 100-pair 24 AWG communications wire	.90

Cable Cutters – Coaxial

- Cable-gripping jaws quickly score jacket and insulation, and easily cut through copper inner conductor.
- Blades cleanly cut aluminum and copper coaxial cable without compression and frayed ends.
- Forged body with heat-treated and precision-ground steel blades, withstands frequent cutting.
- Hot-riveted design requires no adjustment while maintaining a smooth, precise operation.
- Compact, lightweight design fits perfectly in any professional's tool pouch.
- Handles are plastic-coated for maximum comfort and gripping power.

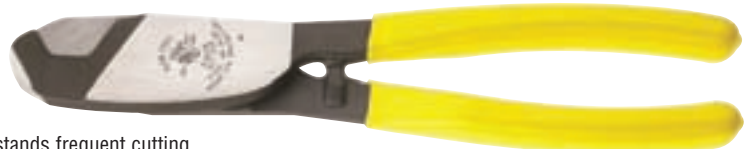

63028

Cat. No.	Overall Length	Handle Color	Soft Cable-Cutting Maximum Capacity	Weight (lbs.)
63028	8-1/4" (216mm)	yellow	.75" (19mm) diameter	.80

Ratcheting Cable Cutters

- Cleanly cuts copper up to 400 MCM, as well as aluminum and multi-conductor cables up to 600 MCM.
- Unique ratchet action holds cable tight and allows rapid, straight cuts with minimum effort.
- Hold-open spring speeds cutting action.
- Quick-release lever opens blade at anytime during operation.
- Large, finger-formed handles have limit guards and plastic covering for comfort.
- Compact, lightweight tool can be locked in closed position for pouch carrying.
- Not designed for cutting steel or ACSR.



63060

Cat. No.	MCM Maximum Cable Capacity			Length	Weight (lbs.)
	Copper	Aluminum	Communication Cable		
63060	Maximum: 400 kcmil (MCM) (185mm ²)	Maximum: 600 kcmil (MCM) (300mm ²)	Maximum: 1-1/8" (28mm)	10-1/4" (260mm)	1.32 lbs. (600g)

Knives and Scissors

Electrician's Scissors – Stripping Notches

- Upper blade has notches for stripping 19 AWG and 23 AWG wire.
- Designed for telecom and electrical applications and heavy-duty use.
- Strong, tough tempered steel.
- Nickel-plated finish resists corrosion.
- Scraper and file on outside of both blades.
- Screw hinge permits adjustment.
- Serrated lower blade reduces slippage.



Cat. No.	Overall Length	Cutting Length	Weight (lbs.)
2100-7	5-1/4" (133mm)	1-7/8" (48mm)	.20

Cable-Splicer's Kit

- Includes cable-splicer's knife, electrician's scissors and 2-pocket leather pouch.
- Cuts cable, telephone wire and strips insulation.
- Dimensions: 2-1/8" x 7-1/2" (54mm x 191mm).
- Contains:
 - 44200 - cable-splicer's knife
 - 2100-7 - electrician's scissors with stripping notches
 - 5187 - slotted leather holder for belts up to 2" (51mm) wide.



Kit - 46037

44200

5187

2100-7

Cat. No.	Weight (lbs.)
46037	.50

Hand Tools

Hand Tools - Wrenches

Combination Wrenches – Satin Finish

12 Pt. Flat Stem

Part No.	A Nom. Size	L	C	B	D	E
1108	1/4"	4-59/64"	35/64"	5/16"	11/64"	13/64"
1110	5/16"	5-1/2"	43/64"	3/8"	3/16"	15/64"
1112	3/8"	6"	51/64"	29/64"	7/32"	17/64"
1114	7/16"	6-1/2"	15/16"	17/32"	1/4"	19/64"
1116	1/2"	7-5/32"	1-1/16"	19/32"	17/64"	11/32"
1118	9/16"	7-15/16"	1-11/64"	11/16"	19/64"	23/64"
1120	5/8"	8-35/64"	1-19/64"	3/4"	5/16"	13/32"
1122	11/16"	9-1/8"	1-27/64"	53/64"	11/32"	7/16"
1124	3/4"	10-3/64"	1-35/64"	29/32"	23/64"	15/32"
1126	13/16"	10-53/64"	1-43/64"	63/64"	27/64"	1/2"
1128	7/8"	11-3/4"	1-51/64"	61/64"	7/16"	33/64"
1130	15/16"	12-9/16"	1-29/32"	31/32"	15/32"	17/32"
1132	1"	13-5/16"	2-1/32"	1-13/64"	15/32"	5/8"
1134	1-1/16"	14-1/4"	2-5/32"	1-19/64"	31/64"	21/32"
1136	1-1/8"	15-1/8"	2-17/64"	1-23/64"	35/64"	11/16"
1138	1-3/16"	15-15/16"	2-25/64"	1-7/16"	9/16"	23/32"
1140	1-1/4"	16-13/16"	2-1/2"	1-33/64"	19/32"	3/4"



Flat Stem

12 Pt. Heavy-Duty Flat Stem

Part No.	A Nom. Size	L	C	B	D	E	F	G
1142	1-5/16"	19"	2-11/16"	1-15/32"	23/32"	7/8"	1"	3/4"
1146	1-7/16"	21"	3"	1-19/32"	3/4"	15/16"	1-1/16"	7/8"
1148	1-1/2"	22"	3"	1-21/32"	3/4"	15/16"	1-1/16"	7/8"
1152	1-5/8"	23"	3-1/2"	1-15/16"	3/4"	15/16"	1-1/8"	7/8"
1156	1-3/4"	25-1/2"	3-3/4"	2-1/16"	13/16"	1"	1-1/4"	1"
1158	1-13/16"	25-1/2"	3-3/4"	2-3/32"	13/16"	1"	1-1/4"	1"
1160	1-7/8"	28"	4-1/16"	2-3/16"	7/8"	1-1/16"	1-1/4"	1"
1164	2"	28"	4-1/16"	2-5/16"	7/8"	1-1/16"	1-1/4"	1"
1166	2-1/16"	28-1/4"	4-1/4"	2-11/16"	59/64"	1-7/32"	1-1/4"	1"
1168	2-1/8"	28-1/2"	4-1/4"	2-25/64"	59/64"	1-7/32"	1-1/4"	1"
1170	2-3/16"	28-3/4"	4-1/4"	2-27/64"	59/64"	1-7/32"	1-1/4"	1"
1172	2-1/4"	29"	4-1/4"	2-29/64"	59/64"	1-7/32"	1-1/4"	1"
1176	2-3/8"	29-1/4"	4-1/2"	2-15/32"	1"	1-9/16"	1-3/8"	1-1/8"
1180	2-1/2"	29-1/2"	4-1/2"	2-1/2"	1"	1-9/16"	1-3/8"	1-1/8"
1182	2-9/16"	29-3/4"	4-1/2"	2-1/2"	1"	1-9/16"	1-3/8"	1-1/8"
1184	2-5/8"	29-3/4"	4-3/4"	2-5/8"	1-1/32"	1-5/8"	1-3/8"	1-1/8"
1188	2-3/4"	29-3/4"	4-3/4"	2-3/4"	1-1/32"	1-5/8"	1-3/8"	1-1/8"

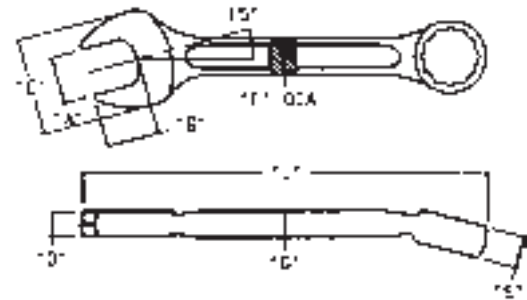

**11 Pieces –
Set No. 711**

**12 Pt. Combination
Wrenches**



Part No.	Description	Part No.	Description
1112	3/8"	1124	3/4"
1114	7/16"	1126	13/16"
1116	1/2"	1128	7/8"
1118	9/16"	1130	15/16"
1120	5/8"	1132	1"
1122	11/16"	711-ROLL	Denim Tool Roll



**14 Pieces –
Set No. 714**

**12 Pt. Combination
Wrenches**



Part No.	Description	Part No.	Description
1112	3/8"	1128	7/8"
1114	7/16"	1130	15/16"
1116	1/2"	1132	1"
1118	9/16"	1134	1-1/16"
1120	5/8"	1136	1-1/8"
1122	11/16"	1140	1-1/4"
1124	3/4"	714-ROLL	Denim Tool Roll
1126	13/16"		

Hand Tools - Wrenches

Adjustable Wrenches – Cobalt Finish

Iron Cobalt is a new alternate coating to chrome/nickel plating. This new bright finish has shown excellent resistance to wear in abrasive environments.

Part No.	Length	A Max Capacity
9AC06	6"	15/16"
9AC08	8"	1-1/8"
9AC10	10"	1-5/16"
9AC12	12"	1-1/2"
9AC15	15"	1-3/4"
9AC18	18"	2-9/64"
9AC24	24"	2-17/32"

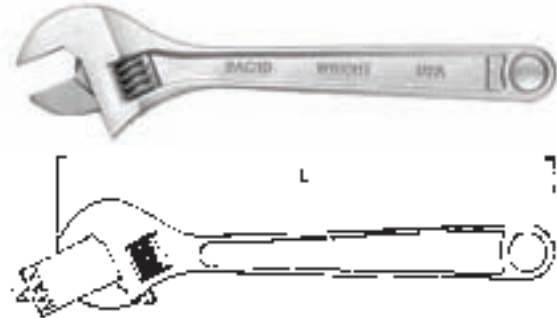

Offset Handle Striking Face Box Wrenches

12 Pt. Black Industrial Finish

Part No.	A Nom. Size	B Dia. of Head	C Thickness of Head	L Overall Length
1932	1"	1-3/4"	13/16"	10-1/2"
1934	1-1/16"	1-3/4"	13/16"	10-1/2"
1936	1-1/8"	1-3/4"	13/16"	10-1/2"
1940	1-1/4"	2"	29/32"	11"
1942	1-5/16"	2"	29/32"	11"
1976	2-3/8"	3-23/32"	1-1/2"	14"
1997	3-1/8"	4-13/16"	2"	16-1/2"
19108	3-3/8"	6-1/4"	2-3/8"	18"
19112	3-1/2"	6-1/4"	2-3/8"	18"
19120	3-3/4"	6-1/4"	2-3/8"	18"
19124	3-7/8"	6-1/4"	2-3/8"	18"
19132	4-1/8"	6-1/4"	2-3/8"	18"
19136	4-1/4"	6-1/4"	2-3/8"	18"



Offset Ratcheting Box Wrenches

12 Pt. Reversible

Part No.	A Nom. Size	B	B-1	C	L
9424	1/4 x 5/16"	21/32"	19/32"	5/16"	4-1/4"
9425	3/8 x 7/16"	7/8"	25/32"	5/16"	5-1/2"
9426	1/2 x 9/16"	1-5/32"	1-1/32"	3/8"	6-1/2"
9427	5/8 x 11/16"	1-7/16"	1-9/32"	3/8"	7-7/8"
9428	3/4 x 7/8"	1-9/16"	1-13/32"	3/8"	8-3/4"

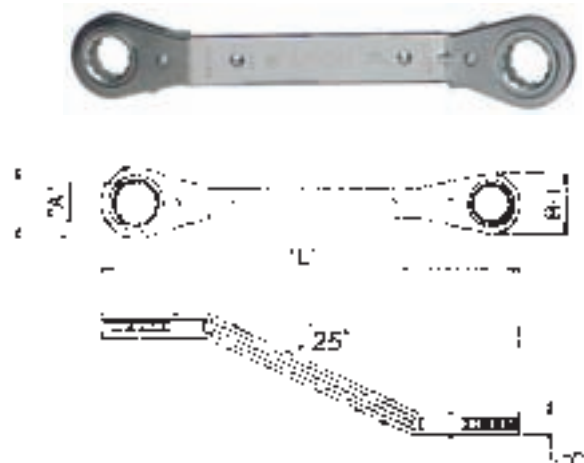

EXPERIENCE THE DIFFERENCE

Hand Tools - Wrenches

Construction – Structural Wrenches Offset Head



Part No.	A Nom. Size	B	C	L
1726	13/16"	2"	17/32"	14-1/2"
1728	7/8"	2"	17/32"	14-1/2"
1730	15/16"	2"	17/32"	14-1/2"
1732	1"	2"	17/32"	14-1/2"
1734	1-1/16"	2-1/4"	5/8"	17"
1736	1-1/8"	2-1/4"	5/8"	17"
1740	1-1/4"	2-13/16"	11/16"	19"
1742	1-5/16"	2-13/16"	11/16"	19"
1746	1-7/16"	3-1/8"	3/4"	20"
1748	1-1/2"	3-1/8"	3/4"	20"
1752	1-5/8"	3-19/32"	13/16"	23"



Part No.	Nom. Size	Nut Type	Bolt Size
1726	13/16"	U.S. Regular	1/2"
1728	7/8"	U.S. Heavy	1/2"
1730	15/16"	Utility	5/8"
1732	1"	U.S. Regular	5/8"
1734	1-1/16"	U.S. Heavy	5/8"
1736	1-1/8"	U.S. Regular	3/4"
1740	1-1/4"	U.S. Heavy	3/4"
1742	1-5/16"	U.S. Regular	7/8"
1746	1-7/16"	U.S. Heavy	7/8"
1748	1-1/2"	U.S. Regular	1"
1752	1-5/8"	U.S. Heavy	1"

Adjustable Construction Wrench Black Industrial Finish

Part No.	A Max.	L
9414	1-19/32"	16"



Construction Spud Ratchet Black Industrial Finish

Features 1/2" drive and a heavy-duty round head.
Requires only 4° arc swing for tight spots.

Part No.	Overall Length	No. of Teeth	Head Dia.	Renewal Kit No.
4428	15"	45	1-5/8"	34401



Broad Head Bull Pins

Part No.	Top Diameter	Point Diameter	Length
9A649	1-1/16"	1/4"	10-3/8"
9A650	1-1/4"	5/16"	13-3/4"





Hand Tools - Sockets

6 Pt. Standard Sockets

Part No.	Nom. Size	Shape	L	Ds	Dd	Bd
3008	1/4"	I	15/16"	7/16"	21/32"	1/8"
3010	5/16"	I	15/16"	15/32"	21/32"	9/64"
3012	3/8"	I	15/16"	37/64"	21/32"	5/32"
3014	7/16"	II	15/16"	41/64"	-	7/32"
3016	1/2"	II	1"	23/32"	-	17/64"
3018	9/16"	II	1"	49/64"	-	21/64"
3020	5/8"	II	1"	55/64"	-	3/8"
3022	11/16"	II	1"	15/16"	-	3/8"
3024	3/4"	II	1-1/8"	1"	-	7/16"
3026	13/16"	II	1-1/8"	1-5/64"	-	1/2"
3028	7/8"	II	1-9/32"	1-9/64"	-	11/16"
3030	15/16"	II	1-3/8"	1-1/4"	-	47/64"
3032	1"	II	1-3/8"	1-5/16"	-	23/32"



Shape I



Shape II



6 Pt. Deep Sockets

Part No.	Nom. Size	Shape	L	Ds	Dd	Bd
3508	1/4"	I	2-7/32"	13/32"	5/8"	5/32"
3510	5/16"	I	2-7/32"	15/32"	5/8"	5/32"
3512	3/8"	I	2-1/2"	35/64"	21/32"	5/32"
3514	7/16"	II	2-1/2"	41/64"	-	7/32"
3516	1/2"	II	2-1/2"	23/32"	-	17/64"
3518	9/16"	II	2-1/2"	49/64"	-	11/32"
3520	5/8"	II	2-1/2"	55/64"	-	3/8"
3522	11/16"	II	2-1/2"	15/16"	-	3/8"
3524	3/4"	II	2-1/2"	1"	-	1-23/32"
3526	13/16"	II	2-9/16"	1-1/16"	-	1-61/64"
3528	7/8"	II	2-7/8"	1-9/64"	-	2-1/4"
3530	15/16"	II	3-3/64"	1-1/4"	-	2-13/32"
3532	1"	II	3-3/64"	1-5/16"	-	2-3/8"



3/8" Drive Ratchet



Part No.	Description	Length Overall	Swing Arc	No. of Teeth	Head Diameter	Renewal Kit No.
3426	Knurled Grip - Double Pawl	7"	1-1/4"	41	1-1/4"	3491

3/8" Drive Speeder

Part No.	Description
3445	Speeder 14-1/2" long



3/8" Drive Extension

Part No.	Description
3408	8"



Hand Tools

EXPERIENCE THE DIFFERENCE

Hand Tools - Sockets

6 Pt. Standard Socket Set – 14 Pieces Set No. 335

Part No.	Description	Part No.	Description
3012	3/8"	3028	7/8"
3014	7/16"	3426	Ratchet
3016	1/2"	3403	3" Extension
3018	9/16"	3405	5" Extension
3020	5/8"	3435	Flex Handle
3022	11/16"	3475	Universal
3024	3/4"	W408	Metal Box
3026	13/16"		



12 Pt. Standard & Deep Socket Set – 29 Pieces Set No. 340

Part No.	Description	Part No.	Description
12 Pt. Standard Sockets			
3108	1/4"	3122	11/16"
3110	5/16"	3124	3/4"
3112	3/8"	3126	13/16"
3114	7/16"	3128	7/8"
3116	1/2"	3130	15/16"
3118	9/16"	3132	1"
3120	5/8"		
12 Pt. Deep Sockets			
3612	3/8"	3624	3/4"
3614	7/16"	3626	13/16"
3616	1/2"	3628	7/8"
3618	9/16"	3630	15/16"
3620	5/8"	3632	1"
3622	11/16"		
Attachments			
3426	Ratchet	3435	Flex Handle
3403	3" Extension	3475	Universal
3405	5" Extension	98	Metal Box



3/8" Drive Hex Bit Socket Set – 7 Pieces Set No. 305

Part No.	Description	Part No.	Description
3204	1/8"	3208	1/4"
3205	5/32"	3210	5/16"
3206	3/16"	3212	3/8"
3207	7/32"	225	Plastic Box



3/8" & 1/2" Drive Hex Bit Socket Set – 10 Pieces Set No. 311

Part No.	Description	Part No.	Description
3/8" Drive Hex Bit Sockets			
3204	1/8"	3208	1/4"
3205	5/32"	3210	5/16"
3206	3/16"	3212	3/8"
3207	7/32"		
1/2" Drive Hex Bit Sockets			
4216	1/2"	4220	5/8"
4218	9/16"	226	Plastic Box



Hand Tools

Hand Tools - Sockets

6 Pt. Standard Metric Socket Set – 17 Pieces
Set No. 366

Part No.	Description	Part No.	Description
30-06mm	6mm	30-15mm	15mm
30-07mm	7mm	30-16mm	16mm
30-08mm	8mm	30-17mm	17mm
30-09mm	9mm	30-18mm	18mm
30-10mm	10mm	30-19mm	19mm
30-11mm	11mm	3426	Ratchet
30-12mm	12mm	3405	5" Extension
30-13mm	13mm	3435	Flex Handle
30-14mm	14mm	W409	Metal Box



6 Pt. Deep Metric Socket Set – 14 Pieces
Set No. 355

Part No.	Description	Part No.	Description
35-06mm	6mm	35-14mm	14mm
35-07mm	7mm	35-15mm	15mm
35-08mm	8mm	35-16mm	16mm
35-09mm	9mm	35-17mm	17mm
35-10mm	10mm	35-18mm	18mm
35-11mm	11mm	35-19mm	19mm
35-12mm	12mm	W110	Rail
35-13mm	13mm	W3	14 Clips



Hex Bit Metric Socket Set – 8 Pieces
Set No. 353

Part No.	Description	Part No.	Description
32-02mm	2mm	32-06mm	6mm
32-02.5mm	2.5mm	32-08mm	8mm
32-03mm	3mm	32-10mm	10mm
32-04mm	4mm	227	Plastic Box
32-05mm	5mm		



3/8" & 1/2" Drive Hex Bit Metric Socket Set – 9 Pieces
Set No. 360

Part No.	Description	Part No.	Description
32-04mm	4mm	32-10mm	10mm
32-05mm	5mm	42-12mm	12mm
32-06mm	6mm	42-14mm	14mm
32-07mm	7mm	42-17mm	17mm
32-08mm	8mm	228	Plastic Box



Hand Tools

EXPERIENCE THE DIFFERENCE

Hand Tools - Sockets

6 Pt. Standard Sockets

Part No.	Nom. Size	Shape	L	Ds	Dd	Bd
4012	3/8"	I	1-1/2"	39/64"	7/8"	5/32"
4014	7/16"	I	1-1/2"	43/64"	7/8"	7/32"
4016	1/2"	I	1-1/2"	47/64"	7/8"	7/64"
4018	9/16"	I	1-1/2"	13/16"	7/8"	21/64"
4020	5/8"	II	1-1/2"	7/8"	-	21/64"
4022	11/16"	II	1-1/2"	63/64"	-	49/64"
4024	3/4"	II	1-1/2"	1-1/16"	-	3/4"
4026	13/16"	II	1-9/16"	1-1/8"	-	13/16"
4028	7/8"	II	1-5/8"	1-3/16"	-	55/64"
4030	15/16"	II	1-5/8"	1-9/32"	-	27/32"
4032	1"	II	1-11/16"	1-23/64"	-	7/8"
4034	1-1/16"	III	1-3/4"	1-7/16"	1-7/64"	29/32"
4036	1-1/8"	III	1-13/16"	1-1/2"	1-7/64"	15/16"
4038	1-3/16"	III	1-7/8"	1-19/32"	1-7/64"	63/64"
4040	1-1/4"	III	1-59/64"	1-21/32"	1-7/64"	1"
4042	1-5/16"	III	1-61/64"	1-13/16"	1-7/64"	1-1/64"
4044	1-3/8"	III	2"	1-7/8"	1-1/4"	1-3/64"
4046	1-7/16"	III	2-1/16"	1-61/64"	1-1/4"	1-3/32"
4048	1-1/2"	III	2-1/8"	2-1/64"	1-1/4"	1-1/8"



Shape I



Shape II



Shape III

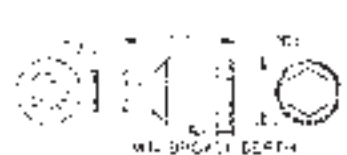

6 Pt. Deep Sockets

Part No.	Nom. Size	Shape	L	Ds	Dd	Bd
4512	3/8"	I	3-3/64"	39/64"	13/16"	5/32"
4514	7/16"	I	3-3/64"	11/16"	13/16"	7/32"
4516	1/2"	I	3-3/64"	47/64"	7/8"	17/64"
4518	9/16"	I	3-3/64"	13/16"	7/8"	21/64"
4520	5/8"	I	3-3/64"	7/8"	-	3/8"
4522	11/16"	II	3-3/64"	63/64"	-	2-11/32"
4524	3/4"	II	3-3/64"	1-1/16"	-	2-21/64"
4526	13/16"	II	3-3/64"	1-1/8"	-	2-19/64"
4528	7/8"	II	3-3/64"	1-3/16"	-	2-9/32"
4530	15/16"	II	3-3/64"	1-9/32"	-	2-17/64"
4532	1"	III	3-3/64"	1-23/64"	-	2-1/4"
4534	1-1/16"	III	3-3/64"	1-7/16"	1-7/64"	2-13/64"
4536	1-1/8"	III	3-3/64"	1-1/2"	1-7/64"	2-11/64"
4540	1-1/4"	III	3-3/64"	1-21/32"	1-7/64"	2-1/8"
4542	1-5/16"	III	3-3/64"	1-13/16"	1-7/64"	2-7/64"
4544	1-3/8"	III	3-3/64"	1-7/8"	1-1/4"	2-3/32"
4546	1-7/16"	III	3-3/64"	1-61/64"	1-1/4"	2-1/16"
4548	1-1/2"	III	3-3/64"	2-1/64"	1-1/4"	2-3/64"



Adaptor

For interchanges of sockets and attachments from one drive size to another.

Part No.	Description	Length
4453	1/2" F x 3/8" M	1-1/2"

1/2" Drive Ratchets



Part No.	Description	Overall Length	Swing Arc	No. of Teeth	Head Dia.	Renewal Kit No.
4425	Long Knurled Grip - Double Pawl	15"	2"	45	1-5/8"	4491
4426	Knurled Grip - Double Pawl	10-1/4"	1-1/4"	45	1-5/8"	4491

Flex Handles



Part No.	Description	Overall Length
4435	Knurled Steel Handle	18"

Speeder



Part No.	Description
4445	Speeder 16-3/4" long

Extension



Part No.	Description
4405	5"
4410	10"
4420	20"

Hand Tools - Sockets

*Torque Wrench – Micro Adjustable
“Click Type” Metal Handle*



Part No.	Drive Size	Torque Range English	Incr.	Torque Range Metric	Incr. (Nm)	Head Style	Length Inches	Wt. Lbs.	Repair Kits
4477	1/2"	20-150 ft. lb.	1	34-197	1.5	Ratchet	19"	3.15	4476B

**12 Pt. Deep Socket Set, 1/2" Drive – 11 Pieces
Set No. 402**

Part No.	Description	Part No.	Description
4616	1/2"	4630	15/16"
4618	9/16"	4632	1"
4620	5/8"	4634	1-1/8"
4622	11/16"	4636	1-1/4"
4624	3/4"	W013	Rail
4626	13/16"	W4	11 Clips
4628	7/8"		



**3/8" Dr. 12 Pt. Std. Socket Set – 13 Pieces
Set No. A31**

Part No.	Size	Part No.	Size
E3112	3/8"	E3126	13/16"
E3114	7/16"	E3128	7/8"
E3116	1/2"	Part No. Description	
E3118	9/16"	E3426	Ratchet, Quick Release, Oval Head
E3120	5/8"	E3403	Extension, 3"
E3122	11/16"	E3405	Extension, 6"
E3124	3/4"	E3590	Sparkplug Socket, 5/8"

**3/8" Dr. 12 Pt. Std. & Deep Socket Set – 21 Pieces
Set No. A34**

Part No. 12 Pt. Std.	Part No. 12 Pt. Deep	Size
E3112	E3612	3/8"
E3114	E3614	7/16"
E3116	E3616	1/2"
E3118	E3618	9/16"
E3120	E3620	5/8"
E3122	E3622	11/16"
E3124	E3624	3/4"
E3126	E3626	13/16"
E3128	-	7/8"
Part No. Description		
E3426		Ratchet, Quick Release, Oval Head
E3403		Extension, 3"
E3405		Extension, 6"
E3590		Sparkplug Socket, 5/8"



Hand Tools

EXPERIENCE THE DIFFERENCE

Hand Tools - Sockets

1/2" Drive, 12 Pt. Standard Socket Set – 16 Pieces

Set No. A41

Part No.	Size	Part No.	Size
E4114	7/16"	E4132	1"
E4116	1/2"	E4134	1-1/16"
E4118	9/16"	E4136	1-1/8"
E4120	5/8"	E4140	1-1/4"
E4122	11/16"	Part No. Description	
E4124	3/4"	E4426	Ratchet, Quick Release, Oval Head
E4126	13/16"	E4406	Extension, 6"
E4128	7/8"	E4410	Extension, 10"
E4130	15/16"		



1/2" Drive, 12 Pt., Double Hex, Standard & Deep Socket Set – 47 Pieces



Set No. A49

- All have a full-polished plated finish
- All sockets are 12-point, double hexes
- Meet ASME B107.1 and ASME B107.10 standards.

Set includes:

- E4426 push button ratchet
- E4402 (2-1/2" in. long) and E4406 (6 in. long) extensions
- E4116 – E4136 11 twelve-point, standard length SAE hand sockets
- E4616 – E4630 8 twelve-point, deep SAE hand sockets
- M4110 – M4124 15 twelve-point, standard length metric hand sockets
- M4610 – M4619 10 twelve-point deep metric hand sockets

1/2" Drive, Hex Bit Socket Set – 7 Pieces

Set No. 405

Part No.	Description	Part No.	Description
4208	1/4"	4216	1/2"
4210	5/16"	4218	9/16"
4212	3/8"	4220	5/8"
4214	7/16"	229	Plastic Box



1/2" Drive, Long Length Hex Bit Socket Set – 7 Pieces

Set No. 406

Part No.	Description	Part No.	Description
42L08	1/4"	42L18	9/16"
42L10	5/16"	42L20	5/8"
42L12	3/8"	W008	Rail
42L14	7/16"	W4	7 Clips
42L16	1/2"		



Hand Tools - Sockets

6 Pt. Standard Impact Sockets

Part No.	Nom. Size	Shape	L	Ds	Dd	Bd
4812	3/8"	I	1-15/32"	21/32"	15/16"	5/32"
4814	7/16"	I	1-15/32"	23/32"	15/16"	7/32"
4816	1/2"	I	1-15/32"	51/64"	15/16"	7/64"
4818	9/16"	I	1-15/32"	7/8"	15/16"	21/64"
4820	5/8"	II	1-15/32"	1"	-	21/64"
4822	11/16"	II	1-15/32"	1-1/16"	-	49/64"
4824	3/4"	II	1-1/2"	1-5/32"	-	25/32"
4826	13/16"	II	1-9/16"	1-15/64"	-	53/64"
4828	7/8"	II	1-5/8"	1-5/16"	-	55/64"
4830	15/16"	II	1-11/16"	1-25/64"	-	29/32"
4832	1"	II	1-23/32"	1-7/16"	-	59/64"
4834	1-1/16"	III	1-3/4"	1-1/2"	1-3/8"	29/32"
4836	1-1/8"	III	1-13/16"	1-5/8"	1-3/8"	15/16"
4838	1-3/16"	III	1-7/8"	1-11/16"	1-3/8"	63/64"
4840	1-1/4"	III	1-15/16"	1-3/4"	1-3/8"	1-1/32"
4842	1-5/16"	III	2"	2-1/64"	1-3/8"	1-1/16"
4844	1-3/8"	III	2-1/16"	2-1/16"	1-17/32"	1-1/8"
4846	1-7/16"	III	2-1/8"	2-5/32"	1-17/32"	1-5/32"
4848	1-1/2"	III	2-3/16"	2-15/64"	1-17/32"	1-3/16"



Shape I



Shape II



Shape III

6 Pt. Deep Impact Sockets

Part No.	Nom. Size	Shape	L	Ds	Dd	Bd
4912	3/8"	I	3-1/4"	21/32"	15/16"	5/32"
4914	7/16"	I	3-1/4"	23/32"	15/16"	7/32"
4916	1/2"	I	3-1/4"	51/64"	15/16"	17/64"
4918	9/16"	I	3-1/4"	7/8"	31/32"	21/64"
4920	5/8"	II	3-1/4"	1"	-	3/8"
4922	11/16"	II	3-1/4"	1-1/16"	-	2-35/64"
4924	3/4"	II	3-1/4"	1-5/32"	-	2-17/32"
4926	13/16"	II	3-1/4"	1-15/64"	-	2-1/2"
4928	7/8"	II	3-1/4"	1-5/16"	-	2-3/4"
4930	15/16"	II	3-1/4"	1-3/8"	-	2-27/32"
4932	1"	II	3-1/2"	1-7/16"	-	2-45/64"
4934	1-1/16"	III	3-1/2"	1-1/2"	1-3/8"	2-21/32"
4936	1-1/8"	III	3-1/2"	1-5/8"	1-3/8"	2-5/8"
4938	1-3/16"	III	3-1/2"	1-3/4"	1-3/8"	2-19/32"
4940	1-1/4"	III	3-1/2"	1-3/4"	1-3/8"	2-19/32"
4942	1-5/16"	III	3-5/8"	2-1/64"	1-3/8"	2-9/16"
4944	1-3/8"	III	3-5/8"	2-1/16"	1-17/32"	2-35/64"
4946	1-7/16"	III	3-5/8"	2-5/32"	1-17/32"	2-17/32"
4948	1-1/2"	III	3-5/8"	2-15/64"	1-17/32"	2-1/2"



Impact Extensions



Part No.	Description
4905	5" Ball Lock
4909	10" Pin Lock

Impact Universal Joint

Part No.	Description	Overall Length
4800	Universal (Pin Lock)	2-11/16"



Impact Adaptors

Part No.	Description	Length
4900	1/2" F x 3/8" M (Ball Lock)	1-1/2"
4902	1/2" F x 3/4" M (Ball Lock)	2"



6 Pt. Deep Impact Socket Set – 14 Pieces

Set No. 407

Part No.	Description	Part No.	Description
4912	3/8"	4928	7/8"
4914	7/16"	4930	15/16"
4916	1/2"	4932	1"
4918	9/16"	4934	1-1/16"
4920	5/8"	4936	1-1/8"
4922	11/16"	4940	1-1/4"
4924	3/4"	2-W010	Rails
4926	13/16"	W4	14 Clips



Hand Tools

Hand Tools - Sockets

6 Pt. Standard Impact Sockets



Part No.	Nom. Size	Ret-Ring	Shape	L	Ds	Dd	Bd
6818	9/16"	6581	I	2-3/32"	1"	1-5/8"	21/64"
6820	5/8"	6581	I	2-3/32"	1-3/32"	1-5/8"	9/32"
6822	11/16"	6581	I	2-3/32"	1-11/64"	1-5/8"	5/16"
6824	3/4"	6581	I	2-3/32"	1-15/64"	1-5/8"	9/16"
6826	13/16"	6581	I	2-1/8"	1-3/8"	1-5/8"	39/64"
6828	7/8"	6581	I	2-1/8"	1-1/2"	1-5/8"	39/64"
6830	15/16"	6581	I	2-1/8"	1-9/16"	1-5/8"	19/32"
6832	1"	6581	II	2-1/8"	1-5/8"	-	35/64"
6834	1-1/16"	6581	II	2-1/8"	1-11/16"	-	1-7/64"
6836	1-1/8"	6582	II	2-1/8"	1-3/4"	-	1-3/32"
6838	1-3/16"	6582A	II	2-1/8"	1-7/8"	-	1-1/16"
6840	1-1/4"	6582A	II	2-1/8"	2"	-	1-3/64"
6842	1-5/16"	6582A	II	2-1/8"	2"	-	1-1/32"
6844	1-3/8"	6582A	III	2-1/4"	2-1/8"	1-29/32"	1-1/8"
6846	1-7/16"	6582A	III	2-1/4"	2-1/8"	1-29/32"	1-1/8"
6848	1-1/2"	6582A	III	2-1/2"	2-5/16"	1-29/32"	1-23/64"
6850	1-9/16"	6582A	III	2-1/2"	2-13/32"	1-29/32"	1-11/32"
6852	1-5/8"	6582A	III	2-1/2"	2-7/16"	1-29/32"	1-5/16"
6854	1-11/16"	6582A	III	2-5/8"	2-1/2"	1-29/32"	1-27/64"
6856	1-3/4"	6582A	III	2-5/8"	2-1/2"	1-29/32"	1-13/32"
6858	1-13/16"	6582A	III	2-5/8"	2-5/8"	1-29/32"	1-3/8"
6860	1-7/8"	6582A	III	2-3/4"	2-23/32"	1-29/32"	1-31/64"
6862	1-15/16"	6582A	III	2-3/4"	2-13/16"	1-29/32"	1-15/32"
6864	2"	6582A	III	2-7/8"	2-3/4"	1-29/32"	1-9/16"
6890	2-1/16"	6582A	III	2-7/8"	2-7/8"	1-29/32"	1-35/64"
6892	2-1/8"	6582A	III	3-1/16"	3"	1-29/32"	1-23/32"
6894	2-3/16"	6582A	III	3-3/16"	3"	1-29/32"	1-13/16"
6896	2-1/4"	6582A	III	3-3/16"	3-1/16"	1-29/32"	1-51/64"
6898	2-3/8"	6582A	III	3-1/2"	3-1/4"	1-29/32"	2-1/16"



Shape I

Shape II

Shape III



Impact Universal Joint

Part No.	Description	Ret-Ring	Overall Length
6800	Universal	6581	3-1/2"



Impact Adaptor

Part No.	Description	Ret-Ring	Overall Length
6901	3/4" F x 1" M	6581	2-1/2"



12 Pt. Standard Socket Set – 19 Pieces

Set No. 618

Part No.	Description	Part No.	Description
6128	7/8"	6152	1-5/8"
6130	15/16"	6154	1-11/16"
6132	1"	6156	1-3/4"
6134	1-1/16"	6158	1-13/16"
6136	1-1/8"	6160	1-7/8"
6140	1-1/4"	6164	2"
6142	1-5/16"	6400	Ratchet
6144	1-3/8"	6408	8" Extension
6146	1-7/16"	6435	Flex Handle
6148	1-1/2"	237	Metal Box



6 Pt. Standard Socket Set – 14 Pieces

Set No. 610

Part No.	Description	Part No.	Description
6824	3/4"	6840	1-1/4"
6826	13/16"	6842	1-5/16"
6828	7/8"	6844	1-3/8"
6830	15/16"	6846	1-7/16"
6832	1"	6848	1-1/2"
6834	1-1/16"	6852	1-5/8"
6836	1-1/8"	22	Metal Box
6838	1-3/16"		



Hand Tools - Sockets

6 Pt. Deep Socket Set – 13 Pieces
Set No. 625

Part No.	Description	Part No.	Description
6524	3/4"	6538	1-3/16"
6526	13/16"	6540	1-1/4"
6528	7/8"	6542	1-5/16"
6530	15/16"	6544	1-3/8"
6532	1"	6546	1-7/16"
6534	1-1/16"	6548	1-1/2"
6536	1-1/8"	23	Metal Box

6 Pt. Deep Impact Socket Set – 8 Pieces
Set No. 608

Part No.	Description	Part No.	Description
6928	7/8"	6940	1-1/4"
6930	15/16"	6942	1-5/16"
6932	1"	6948	1-1/2"
6934	1-1/16"	Cardboard Carton	
6936	1-1/8"		



Fractional Metal Fold-Up Set – 5 Pieces
Set No. 9E20511

Part No.	Description
9E20511	Sizes: 3/16", 7/32", 1/4", 5/16" and 3/8"



Fractional Metal Fold-Up Set – 8 Pieces
Set No. 9E20811

Part No.	Description
9E20811	Sizes: .050, 1/16", 5/64", 3/32", 7/64", 1/8", 9/64" and 5/32"



Fractional Metal Fold-Up Set – 9 Pieces
Set No. 9E20911

Part No.	Description
9E20911	Sizes: 5/64", 3/32", 7/64", 1/8", 9/64", 5/32", 3/16", 7/32" and 1/4"

Hand Tools

Hand Tools - Hammers & Sledges

20 OZ. PRO SERIES FIBERGLASS CURVED CLAW HAMMER



- High-luster, full-polished finish.
- Virtually unbreakable fiberglass handle.
- Solid fiberglass core covered with a molded nylon jacket.
- Resists breakage due to overstrike.
- Contoured handle for increased comfort and reduced fatigue.
- Enlarged handle base for butting material.
- New grip material reduces handle slickness.
- Factory balanced for maximum striking power.
- Permabond® construction between head and handle.

Item#	Head Weight	Length	Face Finish	Claw Type
PLU11400N	20 oz.	13"	Polished	Curved

16 OZ. PRO SERIES FIBERGLASS RIP CLAW HAMMER



- High-luster, full-polished finish.
- Virtually unbreakable fiberglass handle.
- Solid fiberglass core covered with a molded nylon jacket.
- Resists breakage due to overstrike.
- Contoured handle for increased comfort and reduced fatigue.
- Enlarged handle base for butting material.
- New grip material reduces handle slickness.
- Factory balanced for maximum striking power.
- Permabond® construction between head and handle.

Item#	Head Weight	Length	Face Finish	Claw Type
PLU11415N	16 oz.	13"	Polished	Rip

PREMIUM HICKORY AUTOGRAF RIP CLAW HAMMERS



- High-luster, full-polished head, pole, back and sides.
- Quality, red hickory handle.
- Permabond® construction between head and handle.
- Factory balanced.

Item#	Head Weight	Length	Face Finish	Claw Type
PLU11440	16 oz.	13"	Polished	Rip
PLU11442	22 oz.	16"	Checkered	Rip

SOLID STEEL RIP CLAW HAMMERS



- Patent Pending anti-vibration shock absorbing technology.
- Anti-vibration feature absorbs shock and minimizes muscle fatigue.
- 1-Piece forged solid steel construction.
- Co-molded hatchet style handle for increased comfort and control.
- High-luster, full polished finish.
- Magnetic nail starter.

Item#	Head Weight	Length	Face Finish	Claw Type
PLUSS16RN	16 oz.	12.875"	Polished	Rip
PLUSS20RN	20 oz.	13.75"	Polished	Rip
PLUSS22RN	22 oz.	15.875"	Polished	Rip
PLUSS22RCFN	22 oz.	15.875"	Checkered	Rip
PLUSS28RCF	28 oz.	16"	Checkered	Rip

FIBERGLASS BALL PEIN HAMMERS



- Rust-resistant, forged black head with polished poles and peins.
- Professional quality fiberglass handle.
- Permabond® construction between head and handle.
- Comfortable black cushion grip.

Item#	Head Weight	Length
PLU11426	16 oz.	12.75"
PLU11428	24 oz.	15"

HICKORY BALL PEIN HAMMERS



- Ground, black head.
- Polished poles and peins.
- Quality, hickory handle.
- Permabond® construction between head and handle.

Item#	Head Weight	Length
PLU11497	12 oz.	11.25"
PLU11499	20 oz.	12.75"

Hand Tools

Hand Tools - Hammers & Sledges

FORM HAMMER – 16" FIBERGLASS HANDLE



The Razor-Back double milled form hammer is great for concrete work and demolition. It features a 6-pound forged steel head for ultimate safety and durability. Mounted to the head is a 16-inch fiberglass handle with non-slip grip. This tool works well in tight and confined spaces.

Features

- 6 Lb. double milled forged steel head for durability.
- Used for demolition and concrete work.
- Handle features solid fiberglass core for maximum strength.
- Non-slip grip for safety while delivering powerful blows.

Item# **AME1215600**

ENGINEER HAMMER – 16" FIBERGLASS HANDLE



Engineer Hammer features a 16-inch blue fiberglass handle and a 4-pound double face forged steel hammer head, perfect for heavy hammering or demolition work. This unit makes driving spikes or wedges easier. This is a great choice for personal or professional use.

Features

- 4 Lb. double milled forged steel head for durability.
- Perfect for heavy hammering or demolition work.
- Unit makes driving spikes or wedges easier.
- 16" Fiberpro fiberglass handle.

Item# **AME1197000**

ENGINEER HAMMERS – 16" HICKORY HANDLE



Engineer Hammers feature a 16-inch hickory handle and a double face forged steel hammer head, perfect for heavy hammering or demolition work. This unit makes driving spikes or wedges easier. This is a great choice for personal or professional use.

Features

- Forged steel hammer head.
- Perfect for heavy hammering or demolition work.
- Unit makes driving spikes or wedges easier.
- 16" Hickory handle for strength.

Item# **AME1196300** (3-Pound Head)
 Item# **AME1196900** (4-Pound Head)
 Item# **AME1197500** (6-Pound Head)

SLEDGE HAMMERS – 36" FIBERGLASS HANDLE



These sledge hammers feature a 36-inch fiberglass handle and a double face sledge hammer head, perfect for heavy hammering or demolition work. The strong fiberglass handle will last for years.

Features

- Double face forged steel sledge hammer head for maximum strength.
- Perfect for demolition work or heavy hammering.
- 36" Fiberglass handle for maximum core strength and safety.

Item# **AME1197600** (6-Pound Head)
 Item# **AME1198800** (8-Pound Head)
 Item# **AME1199300** (10-Pound Head)
 Item# **AME1199600** (12-Pound Head)
 Item# **AME1199800** (16-Pound Head)

SLEDGE HAMMERS – 36" HICKORY HANDLE



These double face sledge hammers feature a 36-inch American hickory handle for maximum strength and shock resistance. The heads are forged from high-carbon steel and tempered for long life. The striking face is heat-treated for the hardness to withstand many years of heavy blows.

Features

- Double face forged steel head for maximum strength.
- Perfect for destruction work, breaking dry wall or masonry walls
- 36" American hickory handle for maximum shock resistance.

Item# **AME1197900** (8-Pound Head)
 Item# **AME1199100** (10-Pound Head)
 Item# **AME1199400** (12-Pound Head)
 Item# **AME1199700** (16-Pound Head)

Did you know Abatix offers training courses? Located in our Santa Fe Springs, CA, Phoenix, AZ and Jacksonville, FL branches, Abatix Learning Centers offer a variety of certification classes regulated by both governmental and industry related groups, such as OSHA, EPA, Licensing groups (IICRC, IAQA, Maritime, and Construction), as well as product demonstrations and general industry informational sessions. Check our web site for details.

Hand Tools

EXPERIENCE THE DIFFERENCE

Hand Tools - Shovels

#12 POLY SCOOPS

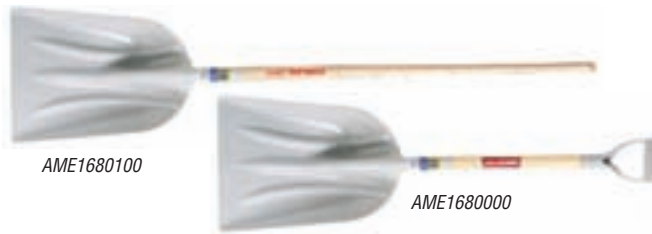

These True Temper lightweight poly scoops are perfect for moving and scooping grain, seed, feed, fertilizers and other granulated materials. They are also useful and versatile garden tools, sturdy enough for general clean-up or for moving mulch, soil or even snow.

Features

- Large, deep ABS poly blade, size #12, perfect for big jobs.
- North American ash handle for long life.
- Ribbed blade for added strength and durability.
- Multi-purpose tool that can be used year round.

Item# **AME1680100** (48" handle)
 Item# **AME1680000** (27" D-grip Handle)

J-250, KODIAK #10 ALUMINUM SCOOP



The Jackson line is designed for consumers and professionals who expect high-quality features and durability. This lightweight aluminum scoop is perfect for moving and scooping grain, seed, feed, fertilizers and other granulated materials. It's also a useful and versatile garden tool sturdy enough for general clean-up or for moving mulch, sand or soil.

Features

- Aluminum blade, size #10, is lightweight, non-sparking and naturally rust proof.
- 27" Sturdy, stained North American ash handle for long life.
- Cushion D-grip for comfort and control.
- Western-pattern, ribbed blade for added strength and durability.

Item# **AME1670900**

AMES EAGLE SHOVELS



The Ames Eagle collection offers economically priced utility shovels for the occasional user.

Features

- Open back tempered steel blade.
- Rolled shoulder for increased strength.
- 47" Long hardwood handle.
- Size - No. 2

Item# **AME1554300** (Round Point - 8¼" x 11" Blade)
 Item# **AME1554500** (Square Point - 9" x 10½" Blade)

AMES CLASSIC SHOVELS (10-Yr. Warranty)



The Ames Classic collection are medium grade shovels, an essential part of any tool assortment. The round point shovel is ideal for digging in all types of soil while the square point is perfect for moving loose garden material, sand, top soil or debris.

Features

- Ideal for occasional users, first time homeowners, or those seeking good value for the price.
- Forward turned step for secure foot placement.
- High carbon tempered steel blade for durability.
- 48" Sturdy, stained North American Ash handle for long life.
- Full size shovel blades.

Item# **AME1551100** (Round Point)
 Item# **AME1551300** (Square Point)

ROUND POINT SHOVEL WITH ROLLED STEP, OPEN-BACK AND DUAL RIVET



The Razor-Back round point shovel is tough enough to dig in the hardest, rockiest soil. It features a heavy-duty, open back, industrial gauge, steel blade. Blade comes with a rolled shoulder step. The open-back blade fits the premium 48-inch white ash handle for strength.

Features

- Ideal for digging and excavation in various soils.
- Largest open-back industrial gauge tempered steel blade with rolled step.
- 11" Extended tab socket reduces handle breakage.
- Premium 48" Northern White Ash handle.

Item# **AME45519**

SQUARE POINT SHOVEL WITH TAB SOCKET AND ROLLED-STEP



Strength and durability make Razor-Back tools the choice of professionals. This sturdy square point shovel is an essential part of any tool assortment. It's perfect for moving loose garden material, sand, top soil or debris. It can also be used to shape beds, mix concrete, level off areas that need to be flat or to scrape stubborn material off driveways or other hard surfaces.

Features

- 48" Sturdy, stained North American Ash handle for long life.
- Industrial gauge open-back blade.
- Rolled-step helps prevent material build-up.
- Dual rivet, extended tab socket for added strength.

Item# **AME44101**

Hand Tools - Shovels

16" DRAIN SPADE WITH POLY D-GRIP



The Union Tools drain spade is designed for digging narrow trenches and cleaning out previously dug ditches. It is also great for transplanting live trees and shrubs. The 27" ash handle with poly D-grip and open back blade makes it accessible for the user to dig in tight places.

Features

- 16" Tempered steel blade for maximum strength.
- 9" Socket.
- Strong poly D-grip.
- 27" Ash handle.

Item# **AME47108**

DITCHING SHOVEL



The Razor-Back ditching shovel is designed for digging and clearing drainage, ditches and trenches. The 5" open-back industrial gauge tempered steel blade has a rolled step to prevent material build-up. 48" premium northern ash handle for strength to withstand digging and clearing drainage.

Features

- Designed for digging and clearing drainage, ditches and trenches.
- 5" Open-back industrial gauge tempered steel blade has a rolled step to prevent material build-up.
- 48" Ash handle.
- 9" Socket for stronger connection between handle and blade.

Item# **AME47115**

4" TRENCHING SHOVEL WITH ROLLED STEP



The Razor-Back trenching shovel is designed for digging and clearing trenches. It features a 4", open-back, industrial gauge tempered steel blade. The blade width is the most common width for trenching applications. The blade is married to a 48" Northern Ash handle for high quality. This is an excellent tool for DIYers and professionals alike.

Features

- 4" Blade is most common size for this type of shovel.
- 9" Socket for additional strength.
- 48" North American Ash handle for strength and durability.
- Commercial grade, 14-gauge steel blade.

Item# **AME47171**

J-250, KODIAK ROOF SHOVEL WITH FULCRUM



The Jackson roofer spade is great for professionals who remove shingles and other roofing materials. Heavy-duty fulcrum is welded to the back of the blade. This steel construction tool is used for frequent and labor intensive jobs.

Features

- Best for removing shingles.
- Use on roofing materials on most surfaces.
- 48" Hardwood handle is flexible and durable.
- Extended blade socket for a stronger connection between handle and blade.

Item# **AME1575500**

Hand Tools - Scrapers

7" SCRAPER



This scraper is a sturdy tool for an exceptional value. It can be used to scrape ice from sidewalks, driveways and other floor surfaces. Use prior to shoveling to help preserve your snow shovel blade. This versatile scraper can also be used to remove roofing, siding and flooring or to chop and remove roots or other garden debris.

Features

- 7" x 5" Blade.
- Welded Shank.
- 48" North American ash handle for strength and durability.
- Multi-purpose tool that can be used year round.

Item# **AME1647800**

J-250, KODIAK 7" SCRAPER



With a heavy-duty, 7" wide blade, this Jackson scraper will scrape ice, concrete or anything else from road or floor surfaces. It can be used to remove roofing, siding and flooring or to chop and remove roots or other garden debris. It's also great for digging, clearing trenches and lawn edging.

Features

- 7" x 6" Blade.
- Forged head.
- 48" North American ash handle for strength and durability.
- Multi-purpose tool that can be used year round.

Item# **AME1646300**

EXPERIENCE THE DIFFERENCE

Hand Tools - Rakes

22-TINE STEEL LEAF RAKE

The True Temper 22-tine steel leaf rake is used for clearing leaves and debris from lawns. The flexible steel tines will pull out thatch for a healthier lawn.

Features

- Can be used to thatch as well as rake.
- Spring brace head for flexibility and strength.
- 48" Painted pine handle.
- Ideal for smaller jobs.

Item# **AME1936300**



14-TINE TRUE AMERICAN BOW RAKE

The True American line is designed for consumers who want American-made, durable tools with high-quality features. This classic bow rake is part of the foundation of any lawn and garden tool collection and is perfect for leveling and loosening all types of soil.

Features

- 14-Tine tempered-steel rake head.
- North American ash handle that is "verified sustainable."
- 54" Handle.
- 10" Cushion grip for comfort and control.

Item# **AME1849400**



36" ALUMINUM LANDSCAPE RAKE (Unassembled)

The True Temper aluminum landscape rake is designed with a wide head to level quickly and smoothly. The 36" aluminum head is lightweight despite its size. It is a heavy-duty rake that is great for contractor and professional use, as well as serious homeowners. Total tool length is 67 inches.

Features

- 36" Aluminum head.
- Strong metal handle.
- Comfortable end grip.
- Strong head connection for years of use.

Item# **AME61036C**



36" ALUMINUM CONTRACTOR LUTE (Unassembled)

The True Temper aluminum landscape rake is designed with a wide head to level quickly and smoothly. The 36" aluminum head is lightweight despite its size. It is a heavy-duty rake that is great for contractor and professional use, as well as serious homeowners. Total tool length is 67 inches.

Features

- 36" Aluminum head.
- Strong metal handle.
- Comfortable end grip.
- Strong head connection for years of use.

Item# **AME63036C**



Abatix' online ordering system is simple to use. Once you are registered and have a customer code, you can create orders, customize shopping lists, and view ordering history, track shipments, view and print invoices and pay bills online. Head over to www.abatix.com and start shopping today.

Hand Tools - Picks

PICK MATTOCK



This strong mattock pick axe is made from forged steel and features two heads of metal, with a pointed end and a flat end. The steel head is heat treated, durable and painted black. With a rugged hardwood handle, a key feature, this tool is ideal to break rock surfaces, concrete or dried soil.

Features

- 36" Hardwood handle with a handle guard provides permanent protection.
- Heavy-duty double forged head features a mattock for planting, tilling, ground preparation and cultivating.
- Ideal for rupturing rock surfaces, concrete and hardened dried soil.
- Rugged wooden handle will withstand repeated striking.

Item# **AME30125**

RAILROAD PICK



This railroad pick is made from forged steel and features two heads of metal, a pointed end and a flat end. The forged steel structure ensures ultimate durability and safety. This tool takes a pounding constantly from digging up roots, fracturing concrete or breaking hardened soil. A hardwood handle with a 36-inch length is useful for gardeners, landscapers and professionals.

Features

- 6 Lb. forged steel head for durability and safety when fracturing compacted soil.
- 36" Hardwood handle with overstrike protective mold ensures safety.
- Rugged wooden handle will withstand repeated striking.
- Utilized for breaking up hard, rocky soil.

Item# **AME30128**

Hand Tools - Hatchets & Axes

1.25 POUND CAMP AXE



The Razor-Back camp axe is ideal for chopping and splitting wood. It has a drop-forged steel head that is hardened and tempered for cutting edge sharpness. Attached to the head is a 14-inch hickory handle that absorbs impact shock before it reaches the user. Overall, this tool is of high quality and constructed for durability.

Features

- Ideal for chopping and splitting wood.
- This 1.25-pound forged steel tempered head with a cutting edge for sharpness is durable and ensures splitting wood effectively.
- Hickory handle absorbs impact shock before it reaches the user.
- Black painted finish, 14" hickory handle for strength.

Item# **AME30332**

2.25 POUND BOY'S AXE



This is a 2.25-pound Boy's Axe that is completely Made in America. It is used to chop wood and clear branches from trees and shrubs. It features a strong traditional hickory handle that will not splinter and will last for years to come.

Features

- Forged steel axe head for maximum strength.
- Used for branch trimming, tree pruning, wood splitting and cutting.
- 2.25 Lb. axe head.
- 28" Hickory handle.

Item# **AME1188700**



20 OZ. EXPERT CALIFORNIA LATH HATCHET



- Full polished head.
- Checkered striking face.
- Thin blade.
- Hickory handle.
- PermaBond® construction between head and handle.

Item#	Head Weight	Length
PLU11544	20 oz.	12.5"

Hand Tools

EXPERIENCE THE DIFFERENCE

Hand Tools - Bars

66" PINCH POINT CROWBAR

TRUE TEMPER



The Pinch Point crowbar is a 66-inch long straight heat-treated steel for maximum strength. This long hand tool has a round tapered handle and is utilized to pry and lever heavy objects. The typical uses for a pinch point crowbar include breaking up clay, concrete and other hard materials.

Features

- 26 Lb. bar.
- 1-1/2" Bar stock / Medium carbon steel construction.

Item# **AME1162500**

72" PENCIL POINT SAN ANGELO BAR



The San Angelo Digging Bar is used for digging and prying of dirt and large rocks. Manufactured from tempered steel for maximum strength and durability. The pencil point bar works in the toughest conditions.

Features

- 17 Lb. bar.
- 1" Hex bar stock / Medium carbon steel construction.

Item# **AME1160300**

36" GOOSENECK WRECKING BAR

The True Temper Gooseneck Wrecking Bar is a 36-inch bar made of quality steel. This tool is used to lever, remove nails, pry boards and generally break things. It also has a single curved end and flattened points with a small slot on both ends for removing nails. The tool construction is durable for longevity.



Features

- 3/4" Bar stock / Medium carbon steel construction.

Item# **AME1171600**

13" UTILITY BAR

The 13-inch Utility bar is designed for strength and durability. Its quality steel construction with tempered ends makes pulling nails, prying, lifting and scraping easier and provides increased strength and durability. Nail slots at both ends for easy nail removal.



Features

- 1/4" x 1-3/8" Stock / Medium carbon steel construction.

Item# **AME1167000**

Pry Bar



Hex Bar

- Provides extra leverage when positioning steel members and aligning bolt holes.
- Forged fit-up bar is pointed on one end.
- Chisel-end is at a 15° angle to give greater leverage.

Catalog No.	Hex Diameter	Length	Weight (lbs.)
3242	3/4" (19mm)	30" (762mm)	3.50
3244	3/4" (19mm)	24" (610mm)	2.50

Hand Tools - Telecom/Datacom Tools



Can Wrench

- Two tools in one; saves space in your pouch.
- One end opens telephone box fasteners, the other end tightens nuts on binding-post terminals.
- The 7/16" socket has a black finish and the 3/8" socket has a silver finish.
- Sockets are 1-1/4" (32mm) deep to fit over long binding posts and are thin-walled for easy access into tight areas.
- Socket ends are color-coded for quick identification of socket sizes.
- Hex-socket design enables using a wrench to obtain extra torque.
- High-impact, break-resistant handle for long and dependable service.
- Sockets are heat-treated, alloy steel.

Cat. No.	Length	Description	Handle Diameter	Weight
68005	7" (178mm)	3/8" and 7/16" hex nut	1" (25mm)	.350 lbs.

Hand Tools - Tie-Wire Tools

Construction Tools

Tie-Wire Reel

- Rugged, lightweight reel is smooth aluminum alloy with wear parts made of steel.
- Feeds pre-coiled wire smoothly, easily and quickly to save time and wire.
- Designed for left- or right-hand use.
- Large, comfortable rewind knob.
- Easily-removed cover plate that permits quick, convenient reloading to handle all types of wire.



27400

Cat. No.	Diameter	Width	Weight (lbs.)
27400	6-1/4" (159mm)	2-25/32" (71mm)	2.35

Heavy-Duty Embossed Tool Belt (medium)

- Strong, heavy-duty leather.
- Equipped with a double-tongue buckle.



5415

Cat. No.	Size	Width	Weight (lbs.)
5415	36" - 44" (914mm - 1118mm)	2" (51mm)	.64

Tie-Wire Reel Pad

- Worn on the belt under the Klein tie-wire reel.
- Made of 3/16" (5mm) thick rigging leather.
- Slots to accommodate belts up to 2" (51mm) wide.
- Underside has a sponge-rubber pad to minimize hip fatigue.
- Holds Cat. No. 27400 tie-wire reel.
- To be used with Cat. No. 5415 belt.



Cat. No.	Length	Width	Weight (lbs.)
27450	7" (178mm)	7" (178mm)	.300

Hand Tools - Hoses

8-PLY FLEXOGEN GARDEN HOSES



- 8-Ply construction – 500 PSI burst strength.
- Double tire cord reinforced for strength.
- Lightweight, coils and handles easily.
- Flow Guard Plus™ protective collar on 5/8" and 1/2" hoses resists kinks at faucet.
- Heavy-duty, crush resistant, Full-Flo® machined metal couplings with built-in washer for tight sealing.
- Kink resistance.
- Polished surface resists abrasions, stains and mildew.

5/8" Hose

Item# GIL10-58050	50 ft.
Item# GIL10-58075	75 ft.
Item# GIL10-58100	100 ft.

3/4" Hose

Item# GIL10-34025	25 ft.
Item# GIL10-34050	50 ft.
Item# GIL10-34075	75 ft.
Item# GIL10-34100	100 ft.

4-PLY REINFORCED VINYL, MEDIUM DUTY GARDEN HOSES



- 4-Ply construction.
- Good burst strength; withstands nozzle shut-off.
- Lightweight and flexible for easy handling.
- Full-Flo brass couplings for unrestricted water flow.
- Kink resistant.
- Weather and abrasion resistant.

5/8" Hose

Item# GIL15-58025	25 ft.
Item# GIL15-58050	50 ft.
Item# GIL15-58075	75 ft.
Item# GIL15-58100	100 ft.

3/4" Hose

Item# GIL15-34050	50 ft.
--------------------------	--------



REINFORCED RUBBER HOSE FOR COMMERCIAL USE AND HOT WATER USE



- Handles hot water up to 180 degrees.
- 400 PSI burst strength.
- Full-Flo brass couplings for unrestricted water flow.
- Double cord reinforced.
- Kink resistant and flexible.
- Abrasion and weather resistant.

3/4" Hose

Item# GIL18-34050	50 ft.
--------------------------	--------

INDUSTRIAL STRENGTH RUBBER/VINYL HOSE FOR COMMERCIAL USE



- 6-Ply construction.
- 500 PSI burst strength.
- Double reinforced for commercial strength.
- Heavy-duty metal couplings with O-ring for tight seals.
- Kink resistance.
- Easy to handle and weather resistant.
- Metal spring protective collar prevents kinks at faucet.

3/4" Hose

Item# GIL25-34050	50 ft.
--------------------------	--------

COMMERCIAL RUBBER/VINYL HOSES



- 6-Ply construction.
- 500 PSI burst strength.
- Double reinforced for commercial strength.
- Heavy-duty metal couplings with O-ring for tight seals.
- Kink resistance.
- Rugged gray cover resists minor abrasions.

5/8" Hose

Item# GIL29-58050	50 ft.
Item# GIL29-58100	100 ft.

Hand Tools

EXPERIENCE THE DIFFERENCE

Hand Tools - Nozzles & Valves

Gilmour

MID-SIZE SOLID BRASS TWIST SPRAY NOZZLE



- All brass valve stem.
- Four large openings at nozzle tip for full flow.
- Front and rear O-ring seals for leak proof shut-off.
- Precise tip angle eliminates side spray.
- Adjustable from fine spray to needle stream to heavy rinse.
- Two turns from closed to open.
- Heavy-duty solid brass construction with comfort grip.

Item# **GIL529**

FULL SIZE METAL PISTOL GRIP SPRAY NOZZLE



- Solid brass valve stem with permanent adjusting nut.
- Hold-open clip for continuous spraying.
- Rust resistant stainless steel spring.
- Self-adjusting "duck" packing for the ultimate leak proof seal.
- Heavy-duty, full size, die cast body.

Item# **GIL573**

FULL SIZE POLYMER WITH THREADED FRONT SPRAY NOZZLE



- Male hose threaded front for attaching accessories.
- Polymer valve assembly with fixed nut.
- Hold-open clip for continuous spraying.
- Self-adjusting "duck" packing for the ultimate leak proof seal.
- Impact resistant, rustproof, full size, polymer body.

Item# **GIL474**

COMFORT GRIP WITH THREADED FRONT SPRAY NOZZLE



- Molded on, black vinyl grip for cushioned comfort.
- Male hose threaded front for attaching accessories.
- Solid brass valve stem with permanent adjusting nut.
- Hold-open clip for continuous spraying.
- Rust resistant stainless steel spring.
- Self-adjusting "duck" packing for lifetime leak proof seal.
- Heavy-duty, full size, die cast zinc body.

Item# **GIL593**

POLY DUAL SHUT-OFF CONNECTOR



- Twin shut-off valves control water flow for two hoses.
- Cap type valve handles resist breakage.
- Longer legs prevent hose kinks at faucet.
- Full ball and retainer rings reduce leakage, even at low pressure.
- Durable, rustproof polymer construction.
- Not recommended for hot water use.

Item# **GIL17**



Hand Tools - Sprayers

LEADER® SPRAYER

Ideal for Light Duty or Occasional Use



- Stable, 6-footed translucent tank with medium funnel top.
- Poly TOV™ thumb-operated shut off valve with in-line filter.
- 18" Curved poly spray wand.
- Pic-A-Pattern™ cone/fan nozzle adjusts from fine mist to long distance stream.
- HPP™ High Performance Pump with glove-sized comfort grip handle.
- 2-Year warranty.

Item# **HUD60183** (3 Gal./11 liter)

WEED 'n BUG ELIMINATOR® SPRAYER

Our Most Economical, Light Duty Sprayer



- Translucent poly tank with funnel top.
- Standard locking on/off switch control valve.
- 12" Poly spray wand.
- Adjustable Poly Cone Nozzle – adjusts from fine mist to long distance stream.
- Efficient "T" handle pump.
- 1-Year warranty.

Item# **HUD60153** (3 Gal./11 liter)

MULTI-PURPOSE™ SPRAYER – Ideal for Medium Duty Use



- Stable, 6-footed translucent tank with funnel top.
- Large, poly TOV™ thumb-operated control valve with in-line filter.
- 18" Curved poly spray wand.
- Cluster™ nozzle with four selectable spray patterns; fan, flooding fan, adjustable cone or foaming.
- HPP™ High Performance Pump with glove-sized comfort grip handle.
- 2-Year warranty.

Item# **HUD20013** (3 Gal./11 liter)

CONSTRUCTO® POLY SPRAYER – Ideal for Many Commercial Jobs



- Stable, 6-footed translucent tank with large funnel top.
- Metal Roto-Valve™ control valve – rotates 360 degrees for ergonomic comfort.
- Strong curved brass 18" spray wand.
- Curved brass spray wand accepts popular 8004E.
- TeeJet® nozzle tip with available 141-680 adapter.
- Brass, flat fan pattern nozzle.
- HPP™ High Performance Pump with easy carry metal "D" handle and push rod.
- Locking pressure release valve.
- 1-Year warranty.

Item# **HUD90183** (3 Gal./11 liter)

INDUSTRO® WATER SUPPLY TANK



Provides Water Directly to Jobsite

- Male GHT fitting fits standard size hose connectors.
- Heavy-duty translucent tank.
- Large funnel top reduces spills when adding chemical.
- HPP™ High Performance Pump with comfort grip, glove-sized handle.

Item# **HUD91134** (3.5 Gal./13 liter)

SUPER SPRAYER™ – Enough Muscle for any Job!
ALL VITON® Seals and Gaskets



- Sprays a wide range of chemicals.
- Stable, 6-footed translucent tank with large funnel top.
- Kem-Oil™ 48" chemical resistant, braided power sprayer style hose.
- Large, comfortable poly Thrustless™ control valve with in-line filter.
- 18" Fiberglass/poly spray wand.
- Two nozzles – flat fan and cone.
- Locking pressure release valve.
- HPP™ High Performance Pump with glove-sized comfort grip handle.
- 1-Year warranty.

Item# **HUD90162** (2 Gal./8 liter)

COMANDO® ENDURALL® GALVANIZED STEEL SPRAYER
Rust Resistant Endurall® Epoxy-coated, Galvanized Steel Tank



- Steel Endurall® tank epoxy-coated inside and out.
- Kem-Oil™ chemical resistant, braided power sprayer style hose.
- Large thumb-operated control valve with lock on for ergonomic comfort – in-line-filter.
- Strong curved brass 18" spray wand.
- Brass, flat fan and Pic-A-Pattern™ dural fan/cone poly nozzles.
- Metal "T" pump handle.
- 1-Year warranty.

Item# **HUD96303E** (2.5 Gal./9.5 liter)

INDUSTRO® GALVANIZED STEEL SPRAYER
Spray Thick™ Curing Compound Sprayer



- Sprays up to 35% solids.
- Endurall® tank epoxy-coated inside & out.
- Separate opening allows filling without removing pump.
- Goodyear® Horizon™ Extreme chemical resistant hose.
- Brass Thrustless™ control valve – lasts longer, shuts off quickly.
- Strong bendable curved brass 24" extra large aperture spray wand.
- 2 Nozzles, 110-10E and 8004E.

Item# **HUD91004CCV** (3.5 Gal./13 liter)

Instrumentation - Gas Detection

GasAlertClip Extreme – SINGLE GAS DETECTOR



- Features
- Durable, reliable and easy to use with no downtime.
 - Record keeping is accurate and easy with automatic event logging.
 - Exceptionally low cost of ownership.
 - Compatible with BW Technologies by Honeywell's MicroDock II automatic test station.
 - Full function self-test of sensor, battery status, circuit integrity and audible/visual alarms.
 - Bright wide-angled visual alarm bars.
 - Built-in concussion-proof boot.
 - Water-resistant.

Item# **BWTGA24XT-X** (O₂)
 Item# **BWTGA24XT-H** (H₂S)

GasAlertMax XT II MULTI-GAS DETECTOR – (H₂S, CO, O₂ and Combustibles)

- IntelliFlash verifies operation and compliance from up to 20 ft. (6.1m).
- Continuous LCD shows real-time gas concentrations.
- Compact, lightweight, water-resistant.
- Compatible with BW MicroDock II automatic test and calibration station.
- Full function self-test of sensor, battery status, circuit integrity and audible/visual alarms on start up.
- Bright wide-angled visual alarm bars
- Built-in concussion-proof boot.
- Integrated sampling pump with reliable diaphragm technology.
- Best in class block detection.
- Multi-language - English, French, German, Spanish and Portuguese.
- Equipped with standard datalogging and event logging.



Item# **BWTXT-XWHM-Y-NA** (H₂S, CO, O₂ and combustibles)

GasAlertMicroClip XT MULTI-GAS DETECTOR – (H₂S, CO, O₂ and LEL)



- Features
- Continuous visual compliance with IntelliFlash.
 - Multi-gas versatility with one-button simplicity.
 - Incredibly thin and lightweight, making it comfortable to wear.
 - Extraordinarily low cost of ownership.

Item# **BWTMC2-XWHM-Y-NA** (H₂S, CO, O₂ and LEL)

GasAlertQuattro MULTI-GAS DETECTOR – (H₂S, CO, O₂ and Combustibles)

- Features
- IntelliFlash verifies operation and compliance to both the user and supervisors from up to 20 ft. (6.1m)
 - One-button operational simplicity.
 - Easy to identify icons for onsite auditing and compliance.
 - Field-proven Surecell sensors offer an unprecedented performance, even in the harshest environments.
 - Easy-to-read, multi-language LCD displays all four gas concentrations (H₂S, CO, O₂ and combustibles) simultaneously
 - Audible, visual and vibrating alarm.
 - Extended alarm bars.
 - Flexible, interchangeable battery options with extended runtimes.

- Full function self-test is initiated upon activation and runs continuously during operation.
- Heartbeat pulses continually during normal operation.
- Extensive datalogging and event logging capability.
- User-options, such as flip display, accessible through IR interface for tamper-proof operation.
- Multi-language support in English, French, German, Spanish and Portuguese.
- Compatible with MicroDock II automated test and calibration system.

Item# **BWTQT-XWHM-R-Y-NA** (H₂S, CO, O₂ and combustibles)



RECHARGEABLE

MicroDock II – AUTOMATED INSTRUMENT DOCKING STATION



- Compatible Detectors:
- GasAlertMicroClip
 - GasAlertMicro
 - GasAlertMicro 5 Series
 - GasAlertClip Extreme (2 and 3 Year)
 - GasAlert Extreme.

Cost effective calibration and bump test management

The most cost effective way to manage the calibration and bump testing of BW Technologies by Honeywell portable gas detectors is through the MicroDock II automated test and calibration system. Fully portable and easily expandable, the MicroDock II requires no computer and provides simultaneous management of up to six modules. Minimize expenses and maximize productivity with the MicroDock II.

Item# **BWTDCK2-2-1E00-N**

Instrumentation - Gas Detection

SINGLE GAS CLIP PLUS – Hydrogen Sulfide (H₂S)



- Features
- Only authorized personnel can place the detector in “hibernate” mode.
 - Unmatched sensor reliability for H₂S.
 - Adjustable alarm set points and real-time gas reading capability.
 - 50% larger battery capacity.
 - Two-way IR comms for event down-loads, bump tests and updates.
 - Programmable unit identification.
 - “Bump check” confirmation/identification.

Item# **GASSGCP-H**

SINGLE GAS CLIP – Hydrogen Sulfide (H₂S)



- Features
- Unmatched sensor reliability for H₂S.
 - Adjustable alarm set points and real-time gas reading capability.
 - 50% larger battery capacity.
 - 0.1 ppm resolution for sensor and display.
 - Two-way IR comms for event down-loads, bump tests and updates.
 - Programmable unit identification.
 - “Bump check” confirmation/identification.

Item# **GASSGC-H**

Dräger X-am® 2000 MULTI-GAS DETECTOR
Specially designed for personal monitoring



- Features
- Crocodile clip fastens securely to clothing.
 - Visual alarm – 360° alarm.
 - Large display – all readings at one glance.
 - DrägerSensors – fast accurate and durable, expected lifetime up to five years.
 - Ergonomic mobile phone design provides a high level of comfort and convenience. Can be used intuitively.
 - Poison-resistant Ex sensor – provides dependable warnings in the event of explosive atmospheres and is highly resistant against sensor poisons such as silicone and hydrogen sulfide.
 - Robust and water-tight. Withstands electromagnetic interference.
 - Gas inlets on two surfaces –functional design ensures that gas can enter the instrument from the top and the front.

Item# **DRA8318910**

Dräger EXTERNAL PUMP

External sampling pump with up to 30 meters (98 feet) of hose can be used as the solution for applications such as confined space entry into tanks, pipelines, etc.

Use with X-am 2000 or X-am 5000

Item# **DRA8319400**



Dräger X-am 5000
The smallest gas detection instrument for up to five gases



- Features
- Secure gas entry from top and front.
 - Visual alarm – 180° alarm.
 - Large display – all readings at a glance.
 - Reflective faceplate – easy to find in the dark or in water.
 - XXS generation of high performance sensors offer the most longevity on the market.
 - Ergonomic mobile phone design provides a high level of comfort and convenience. Can be used intuitively.
 - CO sensor compensates for hydrogen interference up to 2,000 ppm with less than 1% CO response. The catalytic Ex sensor measures 0-100% LEL and 0-100% methane concentration.
 - Water, dust resistant. Insensitive to electromagnetic interference.
 - Fast testing and calibration solutions that same time.
 - Use standard alkaline or rechargeable NIMH batteries.

Item# **DRA4543781**

Dräger ACCURO® PUMP

The Dräger Accuro bellows pump is a hand aspirated tube pump which allows user to draw samples with only one hand.

Item# **DRA64000**



Instrumentation

Instrumentation - Gas Detection

ALTAIR® SINGLE-GAS DETECTOR, Oxygen (O₂) Detection
Over two years' service life, maintenance free!



- Features
- Maintenance-free service life – Two years or 1080 alarm minutes (18 hours) of service life with no maintenance. No sensor or battery changes are needed. Long-life lithium battery.
 - By confirming Gas Test with a single button press, the unit allows for a simple bump check to be recorded and displayed onscreen via a checkmark for 24 hours.
 - Sensors – industry standard fast-responding 20 Series oxygen sensor and is UL, cUL, ATEX, and Australian standards-approved.

- Records the 25 latest alarm events automatically.
- Rugged suspension clip to be worn anywhere in the breathing area: on the helmet, belt, and many other places.
- Simple, easy-to-read display. Large numeric display allows users to count down service life, alarm conditions, set points, peak reading, and hours in alarm since activation with accuracy and confidence. Display helps users to identify current levels as well as highest and lowest readings at a glance.
- Extra-thick rubberized housing withstands accidental drops. Water and dust resistance.
- Audible alarm sounds at an average of 95 dB @ 1 foot and is designed to be distinctive among other workplace sounds.

Item# **MSA10092523**



ALTAIR® 5 MULTIGAS DETECTOR
Calls for help when you can't.



The new MSA ALTAIR® 5 Multigas Detector raises the bar once again with 6-gas capability, more than 18 preprogrammed languages, high-resolution, crisp color display option, and MSA's exclusive MotionAlert™ and InstantAlert™ features plus the outstanding durability and performance you expect from MSA. Ideal for confined space applications, the MotionAlert™ feature, when enabled, activates a "man down" alarm if no motion is detected for 30 seconds. The InstantAlert™ feature allows users to manually activate an audible alarm to alert those around them to potentially dangerous situations.

- Features
- Logo display screen customization.
 - GALAXY® Test System-compatible.
 - Triple alarms at 95 dB+.
 - Durable rubber/synthetic over-molding.
 - Intuitive 3-button operation.
 - MotionAlert™ and InstantAlert™ features standard.
 - MSA Link™ Software with multi-language capability.
 - Unit passes 6-foot drop test; IP65-rated for water/dust ingress.
 - Real-time on-line monitoring capability with MSA Link Software.
 - 2-Year comprehensive warranty for standard models.

Item# **MSA1094912**

Instrumentation - Gas Detection - Accessory

Calibration Gas



4-gas mix of calibration gasses in 34 liter aluminum cylinder. Includes CH₄ (2.5%), O₂ (18.0%), H₂S (25ppm), CO (100ppm). Balance gas N₂. Requires calibration gas regulator, Item# BWTREG-0.5, (sold separately).

- For use with:
- GasAlertMicroClip XT
 - GasAlertMax XT II
 - GasAlertQuattro
- Item# **BWTCG-Q34-4**

**Calibration Gas Regulator
Constant Flow Regulator**



This constant flow gas regulator is for aluminum calibration gas canisters.

For use with:

- GasAlertClip Extreme
- GasAlertQuattro
- GasAlertMicroClip XT

Item# **BWTREG-0.5**

**Calibration Gas Regulator
Demand Flow Regulator**



This calibration gas regulator is for aluminum cylinders. As a demand flow regulator you can adjust the rate of gas flow.

- For use with:
- MicroDock II
 - GasAlertMax XT II
- Item# **BWTREG-DF-1**

Vehicle Power Adaptor



The 12 VDC in-vehicle power adaptor allows gas detectors to be conveniently recharged from a standard 12V cigar lighter style outlet.

- For use with:
- GasAlertMicroClip XT
 - GasAlertMax XT II
 - GasAlertQuattro
- Item# **BWTGA-VPA-1**





Instrumentation - Air Sampling

T-101 JARLESS SAMPLING PUMP



Lightweight and low maintenance, this rotary vane sampler has a sampling range of 0-30 LPM and is an excellent resource for sampling asbestos (25mm cassettes), lead (37mm cassettes) and mold. This sampler is the best value in the market today, meets OSHA and AHERA standards and comes complete with adjustable aluminum stand, six feet of vinyl tubing, inline filters, rubber feet for stability, handle and built-in switch. Weight 10 lbs.

Construction

- Rigid metal base and housing, powder coated gray
- Adjustable locking pressure regulator
- Rubber feet
- Steel handle
- Built-in ON/OFF switch
- 7"L x 3.75"W x 6"H

Pump

- Type: Oil-less, rotary vane
- Vanes: Carbon construction (4 ea./ replaceable)
- Filter, Inlet: Foam (internal)
- Exhaust Filter: Foam (internal)
- Performance: 0-30 LPM (adjusted via pressure regulator)

Item# **ALG9801**

AIR SAMPLING PUMP KIT – The Abatement Air Sampling Pump

Features

- 500-3000 cc/min.
- Anti-tamper control covers.
- Sealed internal components – Sealed flow adjustment and on/off switch protect the BDx-II from moisture, dust and fibers.
- Rechargeable NiMH battery pack.
- Easy calibration.
- UL approved for operation in hazardous areas.
- Rugged and dependable construction.
- Built-in rotameter monitors flow rates over the entire flow range of 0.5-3.0 LPM and an electronic flow control adjustment enables parts to last longer.
- Externally mounted filter protects the internal pneumatics from dirt and debris. Easily inspect filter condition and replace when necessary.

Item# **SESBDX-II**



- Kit includes:
- BDx-II Pump
 - 36" Tubing
 - Clip Assembly
 - Reversible Screwdriver
 - User Manual
 - Single Unit Charger.

ZEFON BIO-PUMP® PLUS FOR INDOOR AIR QUALITY (IAQ) SAMPLING



Features

- New 'Quick Sample' feature makes sampling a breeze.
- Extra Long Battery Life - Take over 100 samples on a single charge.
- Very small size and weight - Over 40% less than the standard Zefon Bio-Pump.
- Very quiet operation.
- Programmable timer allows unattended operation.
- Quick-charge battery charger included (approx. 3 hours).
- Uses Air-O-Cell® cassettes - the only industry proven and standardized sampling cassettes.
- Uses Via-Cell® cassettes - the only cassette style sampler offering both viable and non-viable analysis options.
- Nothing to prepare or clean. Just place the cassette on the pump, set the time and go.
- Each Pump comes complete with both an Air-O-Cell® and Via-Cell® flow indicator, quick charger, 10 FREE Air-O-Cell® cassettes and a handy carrying case.

Specifications

- Flow Rate: 15 LPM.
- Housing: ABS, Black.
- Battery: Nickel Metal Hydride.
- Sampler Size: 4.375" W; 8" D; 2.75" H / Weight: 1.6 lbs.

The Zefon Bio-Pump® Plus is the smallest and lightest portable battery powered IAQ sampling pump available. It provides the simplest and most convenient way to sample with Air-O-Cell® and Via-Cell® cassettes at a flow rate of 15LPM.

Item# **AMCZBP200**

EXPERIENCE THE DIFFERENCE

Instrumentation - Air Sampling

Air-O-Cell® – THE PROFESSIONAL'S CHOICE FOR INDOOR AIR QUALITY (IAQ) SAMPLING



Air-O-Cell® is a simple to use tool for the rapid collection of a wide range of airborne particulates. It is specifically designed to capture:

- Bioaerosols – mold spores, pollen, insect parts, skin cell fragments
- Fibers – asbestos, fiberglass, cellulose, clothing fibers, synthetics
- Inorganic Particulates – ceramic, fly ash, copy toner, oil droplets, paint
- Other Opaque Particulates – products of combustion, rust, salts.

Item# **AMCAOC010** (10/Box)

Item# **AMCAOC050** (50/Box)

Air-O-Cell collects viable and non-viable sample specimens, providing a much broader overview of potential allergens and contaminants than conventional sampling techniques. Laboratory analysis of the sample provides feedback about the type and concentration of particulate in the air. Air-O-Cell can be used during routine inspections and investigations to determine if there are abnormally high concentrations of any specific particulates.

Air-O-Cell can be used with any standard off-the-shelf area sampling pump capable of drawing 15 LPM open flow. The compact size makes Air-O-Cell suitable for use in confined or restrictive spaces.

What Makes Air-O-Cell® the Best?

- **Superior Design** – Air-O-Cell is based on 30+ years of scientifically proven slit impaction technology converted into an easy to use disposable cassette.
- **Complete Aero-Allergen Sampling** – Air-O-Cell reliably collects not only mold and pollen but many other particulates that effect human health.
- **Consistency** – For over 10 years the patented design of Air-O-Cell has allowed laboratories and researchers the ability to amass a wealth of consistent collection data - all based on a unique single collector design.
- **Best Value** – Competitively priced, the “The Air-O-Cell Advantage” provides proven acceptance in the scientific and legal community.
- **The Professional's Choice** – With 9 out of 10 professionals choosing Air-O-Cell over the competition it is very clear that the superior design and quality of Air-O-Cell is unmatched in the industry.



Slit Impaction Technology

For collecting particles, Air-O-Cell uses slit impaction as its method of collection. Airborne particles pulled through the cassette are accelerated as they approach and drawn through a small slit aimed directly at a glass slide holding the sampling media. Air velocity forces the particles to impact into the sticky and optically clear sampling media which can permanently hold the collected particles.



After sampling, the entire cassette is transported to a laboratory where the glass slide is removed and analyzed.

Sample Analysis & Results

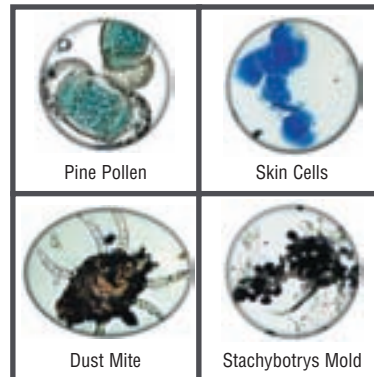

Air-O-Cell is analyzed by a laboratory using direct microscopy techniques. The results from this analysis will provide detailed information about what types of particles along with their concentration were in the air at the time the sample was collected.

With its superior collection design and analysis techniques, Zefon Air-O-Cell is the leading choice of professionals in the field and in the laboratory for the collection of particulates and the evaluation of indoor air quality.

ZEFON 37mm CASSETTES w/MCE FILTERS FOR LEAD SAMPLING



Zefon 37mm Air Sampling Cassette w/ MCE Filters are designed to meet all applicable NIOSH, OSHA and EPA air sampling standards. All Zefon 37mm cassette housings are manufactured in-house and preloaded

under stringent quality assurance standards with only the finest quality membrane and support pads.

Features:

- 3-Piece polystyrene housing
- Preloaded, ready to use
- Leak free design.

Item# **AMC738MCE**

ZEFON PCM & TEM 25mm CASSETTES FOR ASBESTOS SAMPLING



Zefon PCM and TEM 25mm air sampling cassettes are designed and manufactured to meet all applicable NIOSH, OSHA, and EPA standards. The cassette housings are injection molded in-house and are individually assembled and preloaded under stringent quality control standards. Once assembled, each cassette is individually tested prior to packaging for shipment. Random lot sample testing is performed daily by an independent laboratory to ensure low background fiber counts.

Features:

- Quality 0.8um MCE Filter Material (PCM)
- Quality 0.45um MCE Filter Material. 5.0um Filter is placed under the 0.45um filter as a diffuser (TEM)
- 2" Static Conductive Extension Cowl
- Preloaded - ready to use

Item# **AMCZ008BA** PCM (Phase Contrast Microscopy) Cassette

Item# **AMCZ045BA** TEM (Transmission Electron Microscopy) Cassette

OMNIGUARD™

Instrumentation - Pressure Recorder

OMNIGUARD™ 4 – PRESSURE RECORDER



Features

- Notify offsite personnel of alarm conditions via text message or email using optional cellular wireless modem. The wifi adapter accessory will send alarm conditions and job logs via email.
- USB Type-A port lets you save logs directly to a flash drive.
- 512k Log space, four times more than previous versions.
- Blue LCD with brighter backlight is even easier to read.
- Bigger window allows viewing pressure reading

- Menu driven interface for easy setup.
- Instant on screen help.
- Multiple reports available at the touch of a key.
- 95 Decibel audible alarm notifies workers and bystanders when containment is lost.
- Second USB port supports PC communication for transferring job logs, real time monitoring and configuration editing.
- Thermal printer, no ink ribbons.
- Print in any position – paper contained in a protected compartment.
- Print/log interval adjustable to conserve paper and memory.
- Variable response rate to avoid nuisance alarms in windy environments.
- Passcode protection prevents tampering.
- Automatic printout and logging of all settings changes.
- Configuration report prints current settings and monitoring status for easy review.
- View log on screen, scroll through entire memory contents.
- Rugged self-contained unit includes power cord, owner's manual, 10' of hose and spare paper roll stored in the case.

Item# **ENG515-064**

from further away.

- Optional Omniguard USB Port Adapter with relay outputs can trigger remote alarm and autodialer at the same time.
- Real time monitoring of differential pressure and/or vacuum level.
- Dual inlet ports allow monitoring between two areas.
- Programmable high and low alarm setpoints.
- Extremely simple to set up and use.
- Pressure displayed in Inches WC, Millimeters WC or Pascals.
- 30+ Day internal memory stores pressure readings and alarm occurrences with a time/date stamp.
- Large graphic display with white backlight shows current pressure, monitoring status and alarm settings at a glance.

Omniguard™ Paper



Omniguard thermal printer paper for Omniguard 2, 3 or 4.

85' Roll, 2.25" wide.

5 Rolls/box.

Item# **ENG201-211**



SERIES MARK II – INCLINED/VERTICAL MANOMETER
Molded Plastic Air Velocity Meter

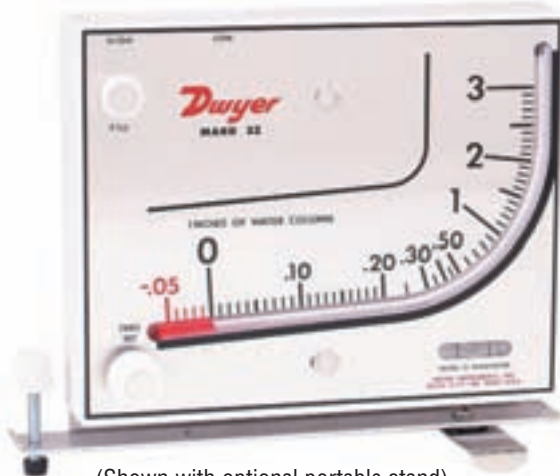

(Shown with optional portable stand)

Construction is simple with virtually indestructible molded white styrene-acrylonitrile housing, indicating tube and fluid wells, molded ABS knobs and zero adjust plunger, shock mounted glass level vial and leak proof "O" ring seals. Scales are lithograph printed on aluminum and epoxy coated.

For stationary applications, the Mark II air velocity meters can be easily mounted on any vertical surface with the two screws provided. A built in spirit level simplifies leveling.

Just fill the reservoir, adjust fluid level to zero, connect the Pitot tube, and it is ready for operation.

Specifications

- Accuracy: $\pm 3\%$ FS.
- Temperature Limits: 140°F (60°C).
- Pressure Limits: 10 psi (70 kPa).

Item# **DWY25**

EXPERIENCE THE DIFFERENCE

Instrumentation - Moisture Meters



TechCheck PLUS MOISTURE METER

Given the challenging conditions of building inspection, installation and drying jobs, it pays to have an easy-to-use moisture meter that you can depend on. The easy-to-use 2-in-1 TechCheck PLUS was designed with simplicity in mind and helps to make even the most demanding job simple. The newly updated TechCheck PLUS has all the great features you've come to expect, along with some new ones.



- Features
- Bright, clear digital display.
 - **Pin mode:**
 - 0.1% - 6% Drywall scale, Delmhorst Exclusive
 - 5%-60% MC wood scale
 - Integral Contact pins mounted on top of meter provide 5/16" penetration
 - Built-in connector accepts any Delmhorst electrode.
 - **Scan Mode:** (0-300 numerical reference scale).
 - Spanish language option.
 - Built-in back-light makes reading in dark places a cinch.
 - Auto-shutoff timer saves battery life.
 - Audible, adjustable alarm alerts you when your pre-selected MC has been reached.

- Size: 8 1/2" x 3 3/8" x 1 3/4" / Weight: 11 oz.
- Rugged construction ensures years of reliable use.
- Sturdy plastic carrying case.
- 9V Battery.
- 1-Year warranty.

Item# **DLMTECHCHECK/PKG** (Includes meter, carrying case and additional contact pins.)

HT-3000 THERMO-HYGROMETER

The HT-3000 Thermo-hygrometer is a great tool for monitoring the level of humidity in flooring installations, building inspections, restoration jobs, and even agriculture operations. With a simple interface, fast acclimation, and useful statistics like dewpoint and grains per pound, the HT-3000 is a great value at an economical price.



- Features
- Bright, clear digital display.
 - Fast response time.
 - Relative humidity range: 0%-100%.
 - Temperature Range: -4°F - 158°F (-20°C - 70°C).
 - Dew Point Range: -40°F - 158°F (-40°C - 70°C).
 - GPP Range: 1 GPP - 2000 GPP (.1 GPK - 285 GPK).
 - Automatic Power Down.
 - Reading HOLD Feature.
 - Size: 8" x 3" x 1 5/8".
 - Weight: 10 oz.
 - Rugged construction ensures years of reliable use.
 - Sturdy plastic carrying case.
 - 9V battery
 - 1-Year warranty.

Item# **DLMHT-3000**

BD-2100 MOISTURE METER

The best-selling BD-2100 is great for measuring moisture in a variety of different building materials, including wood, concrete, drywall, EIFS, roofing, insulation and flooring. The BD-2100 has a digital display, an adjustable alarm and Delmhorst's exclusive calibrated drywall scale.



- Features
- Bright, clear digital display.
 - Three scales:
 - **Wood Scale** - 6% - 40% moisture range. Use for flooring and building material, such as wood studs, floor joists, subfloors
 - **Reference Scale** - reads from 0 - 100 on a relative basis. Use on non-wood materials, such as concrete, plaster, and insulation
 - **Gypsum Scale** - 0.2%-50% moisture range. Use on drywall.
 - Averages up to 100 accumulated readings.
 - Built-in calibration check.
 - Audible, adjustable alarm alerts you when your pre-selected MC has been reached.

- Integral contact pins mounted on top of meter provide 5/16" penetration.
- Built-in connector accepts any Delmhorst electrode.
- Size: 8" x 3" x 1 5/8" / Weight: 10 oz.
- Rugged construction ensures years of reliable use.
- Sturdy plastic carrying case.
- 9V Battery.
- 1-Year warranty.

Item# **DLMBD2100/PKG** (Includes meter, carrying case and extra contact pins.)

J-4 MOISTURE METER

A tried and true solution for installers, woodworkers and small shops, the J-4 is a user-friendly meter that you'll pick up with ease, but never want to put down!



- Features
- Easy-to-read analog display.
 - Moisture Range: 6%-30% on wood.
 - Built-in calibration check.
 - Integral contact pins mounted on the meter provide 5/16" penetration.
 - Built-in connector accepts any Delmhorst electrode.
 - Size: 8" x 3" x 1 5/8".
 - Weight: 10 oz.
 - Rugged construction ensures years of reliable use.
 - Sturdy plastic carrying case.
 - 9V battery.
 - 1-Year warranty.

Item# **DLMJ-4W/CS** (Includes meter, carrying case, and extra contact pins for the meter.)

Instrumentation - Moisture Meters

Navigator Pro THERMO-HYGROMETER



Features

- Simplified menu options in Basic Mode for quick and easy use.
- Job definition of up to 5 jobs with unique Job ID numbers in Enhanced Mode.
- Data grouping by specific rooms, with up to 32 rooms per job.
- **Pin mode:**
 - 5%-60% MC wood scale
 - 0-100 numerical reference scale
 - 0.1% - 6% drywall scale.
- **Scan Mode:** 0-300 numerical reference scale.
- **Thermo-hygrometer:**
 - Measures temp/RH
 - Calculates GPP/dew point
 - Fast response time.
- Store up to 1400 readings with date, time, room, and location stamp.

- View stored readings on screen.
- Optional software – download readings and generate Excel reports.
- Size: 8 1/2" x 3 3/8" x 1 3/4" / 11 oz.
- Rugged construction – years of reliable use.
- Sturdy plastic carrying case.
- 1-Year warranty.

Item# **DLMNAVPRO-PR** (Meter, (1) RHT-S1 humidity sensor, carry case, 2-E electrode, and PC/KIT software application program.)

BD-10 MOISTURE METER

Easy to operate and easy to read, the BD-10 measures moisture in wood and other non-wood building materials. For those who prefer an analog display, the BD-10 is a great alternative to the digital BD-2100. The BD-10 is a great entry level meter, and is ready to go with a single button press!



Features

- Easy-to-read analog display.
- Two scales:
 - **Wood Scale** - 6% - 40% moisture range. Use for flooring and building material such as wood studs, floor joists, subfloors
 - **Reference Scale** - reads from 0 - 100 on a relative basis. Use on non-wood materials such as concrete, plaster, and insulation.
- Built-in calibration check.
- Integral contact pins mounted on top of meter provide 5/16" penetration.
- Built-in connector accepts any Delmhorst electrode.
- Size: 8" x 3" x 1 5/8" / 10 oz.
- Rugged construction – years of reliable use.

- Sturdy plastic carrying case.
- 9V battery.
- 1-Year warranty.

Item# **DLMBD10/PKG** (Meter, carrying case, extra contact pins for the meter, and 21-E electrode.)

WETCHEC – Build customer confidence and promote your business.



Give a WetChec to adjusters and customers to help them understand what's wet and what's dry. Personalize it with your business information and hand it out to referral sources – it's much more memorable than a business card.

Features

- Quick moisture check – audible signal when moisture exceeds 17%.
- Makes a memorable gift to clients and customers.

Item# **DRIF213**

HYDROSENSOR II – Easy moisture detection.



Map the migration of water in carpet and pad without straining your back. The HydroSensor II has a collapsible shaft that extends to 31 inches. Sensitive nickel-plated points alert you to moisture content above 17 percent. Use only on carpet and pad.

Features

- Extends to 31" for use / Collapses to 21" for storage.
- Stainless steel construction / Nickel-plated, retractable points.

Item# **DRIF251**

GE PROTIMETER SURVEYMASTER – Search and measure with the same tool.



The Surveymaster offers two ways to monitor the moisture content of materials: penetrating pins and non-invasive radio frequencies. Use it to distinguish sub-surface from surface dampness, essential information when diagnosing the extent and cause of a moisture problem.

Features

- Detects moisture without making holes in materials, and independently of surface moisture. Uses non-invasive radio frequencies to search for moisture behind finished materials like ceramic tile and vinyl flooring.
- Penetrates materials with pin electrodes to take precise readings of moisture content in wood or Wood Moisture Equivalent (WME) in other materials.

Item# **DRIF281**

EXPERIENCE THE DIFFERENCE

Instrumentation - Moisture Meters



MOISTURE ENCOUNTER PLUS

The Moisture Encounter Plus is a non-destructive overall building inspection tool which has applications for numerous industries. It has many unique features that make moisture measurement and evaluation fast, accurate and versatile.

Industry – Water Restoration, Indoor Air Quality, Pest Control, Home Inspection, Surveying, Flooring, Residential Roofing.

Material – Drywall, wood, plaster, brick, ceramic, porcelain tiles, resilient flooring, laminates, asphalt composition shingles and most building materials.



Features

- Three ranges of sensitivity (Wood/Timber) (Drywall/Roofing) (Plaster/Brick) make it suitable for various building materials.
- Deep signal penetration up to over 1" into the materials being tested without the need to damage the surface.
- External rubber electrodes make direct contact with the material being tested for best sensitivity and repeatability.
- Wide range of readings for wood of 5% to 30% and 0 to 100 comparative for all other materials.
- Large, clear, easy to read display (giving meaningful readings).
- "Hold" function enables user to "freeze" the reading. Useful for taking readings when the meter face is not visible.
- Switchable "On" or "Off" audio warning tone.
- Automatic power cutoff switches "Off" when not in use.
- Automatic default to last user setting when switched back on.
- Battery operated (included).

Item# **TMXMEP**

MOISTURE AND HUMIDITY METER – MRH III

Non-destructive moisture meter for a wide range of materials. Suitable for many industries including flooring, water restoration, IAQ, pest control, home inspection. . .



Features

- Reads non-destructively 1-1/4" deep in woods.
- Adjustment of specific gravity for wood species correction.
- Relative scale of 0-100 for other building materials including drywall, laminate, residential asphalt shingles and masonry products.
- Backlit display for easy viewing in low light conditions.
- Plug in hand wood probe for invasive testing.
- Plug in Hygro-i NEW reusable NIST traceable probe for Relative Humidity, Temperature, Dew-Point and Mixing Ratio readings.

Item# **TMXMRH3**

CONCRETE MOISTURE ENCOUNTER – CME4

For evaluation of moisture condition of concrete, gypsum cement and other slabs and screeds as per ASTM 52659



Features

- Non-destructive in operation.
- No need to probe, drill or mechanically damage the surface.
- Instant readings.
- Clear easy-to-read analog dial.
- Reproducible results.
- Spring-loaded contact pins compensate for uneven concrete and boost signal penetration.

Item# **TMXCME4**

HYGRO-I KIT - MRH3

Perform testing to the latest ASTM F2170 as well as ASTM F2420.



Three modes of operation

- Non invasive moisture content testing of wood.
- Plug in heavy-duty wood pin probe with insulated 7" (200mm) pins for deep wall probing.
- Plug in Hygro-i Humidity Probe for Relative Humidity, Temperature, Dew Point and Mixing Ratio readings.

Item# **TMXMRH3HI1**

Features

- MRH III – Non-destructive moisture meter with built in wood specific gravity species correction.
- Reads 1-1/4" deep in wood. Relative scale of 0-100 for other building materials including drywall, laminate, residential asphalt shingles and masonry products.
- Backlit display for easy viewing in low light conditions.
- Plug in hand wood probe for invasive testing.

- Hygro-i reusable NIST traceable relative humidity probe.

Contents:

- MRH III - Digital, hand-held, non-destructive moisture meter.
- Hole liners and caps (4)
- Brush
- Insertion and extraction tool
- Hygro-i Electronic interface
- 75% RH calibration salt check
- Hygro-i relative humidity probe
- Insulated pins 7" (200mm)
- Hand held pin wood probe
- Infrared surface thermometer.



Instrumentation - Thermal Imaging

COMPACT INFRARED THERMAL IMAGING CAMERAS, Measure Temperature to 248°F (120°C)

Common Features

- Temperature range: -4°F - 248°F (-20°C - 120°C) with 2% accuracy.
- 0.045°C @ 30°C Thermal Sensitivity (N.E.T.D).
- Built-in laser pointer, 3.5" Touch-Screen LCD display.
- Built-in 3.1 Megapixel visible light digital camera with bright LED lamp for poorly lit environments.
- Measurement modes: up to 3 movable Spots, Area (Min/Max/Average), Auto Hot/Cold spot marker, Isotherm (Above/Below), Delta T.
- METERLINK™ Bluetooth® Wireless communication.
- Wi-Fi Connectivity allows you to send images and data to mobile devices.
- Thumbnail Image Gallery function allows quick search of stored images.
- Memory card slot for image storage (more than 1,000 Radiometric JPEG images).
- Complete with Memory card, Li-Ion rechargeable battery, power supply, USB cable, hand strap, lens cap and hard carrying case.
- Includes FLIR Tools software for analysis of radiometric images.

COMPACT INFRARED CAMERA

Point-and-Shoot, Lightweight Thermal Imaging Camera

Common Features

- Compact, Focus-Free, Easy-to-Use and Lightweight (13 oz.).
- Temperature range: -4 to 482°F (-20 to 250°C).
- Thermal Sensitivity (N.E.T.D): i3 - 0.15°C @ 25°C
i5 & i7 - 0.10°C @ 25°C.
- High accuracy of ±2% helps you find problems faster and easier.
- Large 2.8" color LCD, focus-free lens.
- Double molded rugged design with easy grip handle construction meets IP43 dust/splashproof standards.
- MicroSD™ card stores up to 5000 Radiometric JPEG format images.
- Complete with 2G microSD™ Card, Li-Ion rechargeable battery, 110-240V AC adaptor/charger with EU, UK, AU and US plugs, USB cable, hand strap and case.
- Includes FLIR Tools™ software for analysis of radiometric images.

FLIR E40bx – 160 x 120 IR Resolution



Features

- Focal Plane Array detector with 160 x 120 pixels infrared resolution (19,200 pixels).
- Manual focus, 2x continuous zoom.
- Functions include Fixed Picture-In-Picture, Insulation and Humidity Alarm, Voice/Text Annotation, Laser Pointer Marker.

Item# **FLIRE40BX**



FLIR E50bx – 240 x 180 IR Resolution



Features

- Focal Plane Array detector with 240 x 180 pixels infrared resolution (43,200 pixels).
- Manual focus, 4x continuous zoom.
- Functions include Scalable Picture-In-Picture, Thermal Fusion, Insulation and Humidity Alarm, Voice/Text Annotation, Laser Pointer Marker.

Item# **FLIRE50BX**



FLIR i3



FLIR i5



FLIR i7



FLIR i3 – 60 x 60 IR Resolution

Features

- Spot measurement mode.
- 60 x 60 IR detector resolution (3,600 pixels).

Item# **FLIRI3**

FLIR i5 – 100 x 100 IR Resolution

Features

- Spot measurement mode.
- 100 x 100 IR detector resolution (10,000 pixels).

Item# **FLIRI5**

FLIR i7 – 140 x 140 IR Resolution

Features

- Spot, Area (max/min) and Isotherm (above/below) measurement modes.
- 140 x 140 IR detector resolution (19,600 pixels).

Item# **FLIRI7**

EXPERIENCE THE DIFFERENCE



Instrumentation - Thermal Imaging

M12™ 160 X120 THERMAL IMAGER



Features

- Capture Thermal and Visual Images on each trigger pull for enhanced reporting.
- Crisp, High Resolution 160x120 pixel Thermal Images for better definition and clarity.
- Complete Report Software to easily analyze images.
- Broader Temperature Range (-10 to 350°C) to cover more applications.
- 5X Faster Battery charge over closest competitor.
- M12™ RED LITHIUM™ batteries allow for rapid field replacement.
- 3.5" High Resolution LCD (640x480 pixel) for easier troubleshooting.
- Built-In Visual Camera and Flashlight for improved analysis.
- Rugged Overmolding for increased durability and grip.
- Simple screen layout allows you to focus on getting the best images.
- Raised corners protect the LCD and thermal engine if dropped.
- Hinged camera style lens cover is always attached, so is never lost.
- Knurled focus ring is easy to grip with arc flash PPE.
- All Thermal and Visual images use standard JPEG format for use in any program.
- Media door seals the included 2GB SD card and USB connections.

Includes:

- 2260-20 M12™ 160x120 Thermal Imager
- Thermal Imager Report Software
- 2GB SD Card, USB Cable
- M12™ RED LITHIUM™ Battery Pack
- 30 Minute Charger
- SD Card Reader
- Carrying Case
- Thermal Imager Manual
- Software Manual
- Quick Reference Guide
- Statement of Calibration.

Item# **MIL2260-21**

Instrumentation - Lighting Tester

FLUORESCENT LIGHTING TESTER



Features

- Test Lamps, Ballast and Pins – Complete 3-in-1 solution.
- 2.5' Fully retractable antenna for extended reach when testing.
- Non-conductive antenna sleeve allows for safe testing.
- Removable antenna adapter improves lamp test response.
- Visual and audible tool feedback to easily confirm testing.
- Built-in LED flashlight illuminates dark work spaces.
- Dial and buttons positioned for one-handed use.
- Rugged over-molding for increased grip and durability.
- Durable tool that continues to work after a 6.5-foot drop.

Includes:

- 2210-20 Fluorescent Lighting Tester
- Soft Carry Case
- Antenna Adapter
- Manual
- (4) AA Batteries.

Item# **MIL2210-20**

Did you know Abatix offers training courses? Located in our Santa Fe Springs, CA, Phoenix, AZ and Jacksonville, FL branches, Abatix Learning Centers offer a variety of certification classes regulated by both governmental and industry related groups, such as OSHA, EPA, Licensing groups (IICRC, IAQA, Maritime, and Construction), as well as product demonstrations and general industry informational sessions. Check our web site for details.

Janitorial Supplies - Rags, Towels & Paper Products

KRAFT HARDWOUND ROLL TOWELS



- Get high-quality towels at a budget-friendly price.
- Smooth, absorbent paper provides excellent hand-drying performance.
- Fits standard dispensers.
- Size: 8" x 800'

Item# **LAGGEN1825** (6 rolls/case)

HARDWOUND PAPER TOWELS



- One-ply kraft paper towels are hardwound in rolls without perforations.
- For hand drying in commercial washrooms.
- Size: 8" x 350'.

Item# **LAGBWK6252** (12 rolls/carton)

MULTIFOLD PAPER TOWELS



- Fold allows easy dispensing of one towel per pull.
- Use in break rooms, washrooms and wherever a hand towel is needed.
- Size: 9" x 9-1/2".
- White. 250 towels per pack.

Item# **LAGGEN1509** (16 packs/case)

KITCHEN ROLL TOWEL



- Ideal for cleaning and wiping in food service, healthcare, laboratory and clinic settings.
- Convenient dispensing.
- For everyday cleaning and wiping tasks.
- Size: 9" x 11".
- White.

Item# **LAGGEN1799** (30 rolls/carton)

SCOTT NONPERFORATED HARD ROLL TOWEL



- ABSORBENCY POCKETS absorb more water faster for superior hand drying.
- Made of 40% post-consumer waste content with elemental chlorine-free (EFC) bleaching.
- 25% More towels on each core.
- Size: 8" x 1000'.
- White, recycled.

Item# **LAGKCC01005** (6 rolls/carton)

NONPERFORATED ROLL TOWELS



- Roll towels are designed for hardwound roll towel dispensers.
- Quality construction enables multipurpose versatility. Absorbent.
- Size: 8" x 800'.
- Brown.

Item# **LAGWIN1280** (6 rolls/case)

BOUNTY PERFORATED PAPER TOWELS



- Stronger, super absorbent; handles spills fast.
- Improved performance, especially when wet.
- Two-ply, 9" x 10.4" sheets.
- 48 Sheets per roll.
- White.

Item# **LAGPGC81539** (30 rolls/case)

KIMTECH SURFACE PREP WIPERS



- Designed for critical applications involving solvents, inks and paints.
- Low-lint polypropylene construction.
- Perfect for use with lubricants, oil and grease. Great for surface and parts cleaning preparation, glass and window cleaning, and furniture finishing.
- Size: 1/4-Fold, 12-1/2" x 13".
- 66 Wipes per box.
- Blue.

Item# **LAGKCC33560** (8 boxes/carton)

CHUX GENERAL PURPOSE WIPERS



- Soft, highly absorbent material can be used for equipment cleaning, spill cleanup, hand drying and more.
- Ultra-durable design allows both wet and dry use.
- Tear-resistant scrim.
- Size: 9-1/2" x 16-1/2".
- White.

Item# **LAGCHI9070** (900 wipes/box)

CENTER-FLOW PERFORATED PAPER TOWEL ROLL



- Towels dispense singly.
- Absorbent two-ply.
- 8-3/5" Diameter roll.
- Towels have improved brightness, softness and core stability.
- Size: 8" x 13-1/2".
- White

Item# **LAGWIN1420** (6 rolls/carton)

WYPALL X60 WIPERS



- Lighter-weight, extended use wipe.
- Reinforced for extra scrubbing and cleaning power, yet soft enough for face and hands.
- No adhesives or binders.
- Ideal for applying thinners and solvents as well as removing lubricants, grease, soil and adhesives.
- Size: 12-1/2" x 16-7/8".
- White.

Item# **LAGKCC34015** (180/box)

Janitorial Supplies - Rags, Towels & Paper Products

EMBOSSED MULTIFOLD PAPER TOWEL



- High-quality, embossed.
- One-ply.
- Features improved thickness, brightness and consistent coloring.
- Size: 9-1/5" x 9-2/5", 250 towels/pack.
- Bleached white.

Item# **LAGWIN105** (16 packs/carton)

KLEENEX HARD ROLL TOWELS



- One-ply.
- Soft, premium towels.
- Size: 8" x 425'.
- White.

Item# **LAGKCC01080** (12 rolls/carton)

KLEENEX C-FOLD PAPER TOWELS

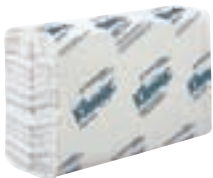

- Embossed towels are ideal for commercial and public restrooms.
- 150 towels per pack.
- Size: 10-1/8" x 13-3/20".
- White.

Item# **LAGKCC01500** (16 packs/carton)

MULTIFOLD PAPER TOWELS



- Folded paper towels are absorbent for everyday use.
- Fold allows easy dispensing of one towel per pull.
- Use in break rooms, washrooms or wherever needed.
- Size: 9" x 9-1/2", 250 towels per pack.
- Kraft.

Item# **LAGGEN1508** (16 packs/case)

WYPALL X70 WIPERS, BRAG BOX



- Tackles heavy-duty industrial jobs usually handled by cloth rags.
- Long-lasting performance extends usage and reduces waste.
- Pound for pound absorbs more oil and water than rags.
- Perfect for surface and tool cleaning as well as heavy-maintenance wiping.
- White / 12-1/2" x 16-4/5".

Item# **LAGKCC41300** (152 wipers/ctn)

WYPALL X70 WIPERS, POP-UP BOX



- Tackles heavy-duty industrial jobs usually handled by cloth rags.
- Long-lasting performance extends usage and reduces waste.
- Pound for pound absorbs more oil and water than rags.
- Perfect for surface and tool cleaning as well as heavy-maintenance wiping.
- Size: 9-1/10" x 16-4/5", 100/box.
- White.

Item# **LAGKCC41455** (10 boxes/ctn)

WYPALL X80 WIPERS, BRAG BOX



- Designed to feel like a cloth and work even better.
- Patented technology allows this thick, strong wiper to absorb oil and water faster than rags or shop towels.
- Retains strength through harsh use, even when used with solvents. Ideal for heavy wiping tasks such as solvent-based surface prepping, metal shaving pickup and rough surface cleansing.
- Steel Blue / 12-1/2" x 16-4/5".

Item# **LAGKCC41041** (160 wipers/box)

ENVISION BATHROOM TISSUE, PLY



- Soft, biodegradable.
- 550 Sheets/roll.

Item# **LAGGPC198-80** (80 rolls/carton)

JUMBO ROLL TISSUE, 2 PLY



- High-capacity rolls, excellent for reducing labor costs in high-traffic areas.
- Soft, white and biodegradable.
- More feet per roll, allowing for less frequent roll changes. (Diameter: 9")
- Made with fiber from sustainable sources.
- Size: 1000' x 3.5", Core size: 3.39".

Item# **GFL13230** (12 rolls/case)

KLEENEX COTTONELLE 2-PLY BATHROOM TISSUE



- The brand you know and trust.
- Offers the soft, plush quality of home.
- Standard size roll.
- Stock up and save!
- 506 Sheets/roll.

Item# **LAGKCC17713** (60 rolls/case)

JUMBO ROLL BATH TISSUE



- Large roll saves time and money on maintenance.
- Fits most jumbo dispensers.
- 9" Diameter.
- Size: 1000'.
- White.

Item# **LAGWIN202** (12 rolls/carton)

SMART SOFT TOILET TISSUE



- 2-Ply.
- 500 Sheets/roll.
- White.

Item# **LAGAPM276** (96 rolls/case)

Janitorial Supplies - Rags, Towels & Paper Products

BATH TISSUE, INDIVIDUALLY WRAPPED



- Economical rolls provide the perfect solution for public restrooms utilizing standard-roll dispensers.
- Soft paper is gentle on the skin.
- Strong and reliable, 2-ply.
- 500 Sheets/roll.
- White.

Item# **LAGGEN238** (96 rolls/case)

JRT BATH TISSUE, JUMBO, BOARDWALK



- 2-Ply.
- Embossed bath tissue for long-lasting and economical performance.
- Reduces need for changing compared to standard rolls.
- 1000 feet roll.
- White.

Item# **LAGBWK6100** (12 rolls/case)

Janitorial Supplies - Can Liners & Bags

LIGHT-GRADE CAN LINERS



- 16 Gallon, 24 x 32, .35 Mil.
- Puncture-resistant, 100% prime resin delivers strength and durability.
- Star-seal bottom design ensures even weight distribution, enabling easy removal from receptacles.
- Coreless, perforated rolls dispense easily and store compactly.
- 25 Liners/roll.
- Black.

Item# **LAGBWK2432L** (20 rolls/case)

LINEAR LOW-DENSITY ECOSAC



- 55 Gallon, 36 x 50, 2.0 Mil.
- Tri-Extruded can liner with a center layer of recycled raw material.
- Star-sealed bottom prevents vacuum at bottom of container that can restrict easy lifting.
- Black.

Item# **LAGESSEC060SXH** (50/case)

SUPER EXTRA-HEAVY BAGS



- 16 Micron gauge.
- Star seal bottom helps prevent leakage.
- High-density polyethylene offers superior film strength ideal for paper and non-sharp objects.
- Perforated for easy tear-off and dispensing convenience.
- 25 Bags/roll.
- White.

Item# **LAGJAGRH3037S** (30-Gal., 30 x 37) (20 rolls/carton)
 Item# **LAGJAGRH3860S** (60-Gal., 38 x 60) (8 rolls/carton)

EXTRA HEAVY CAN LINERS



- 45 Gallon, 40W x 46H, .95 Mil.
- Puncture-resistant, 100% prime resin delivers strength and durability.
- Star-seal bottom design ensures even weight distribution, enabling easy removal from receptacles.
- Coreless, perforated rolls dispense easily and store compactly.
- 25 Liners/roll.
- White.

Item# **LAGBWK4046SH** (4 rolls/carton)

CAN LINER



- 12 Micron gauge rolls.
- 33 x 40.
- Durable liners with star seal bottom prevents vacuum at the bottom of waste containers that can restrict easy lifting.
- Clear.

Item# **LAGESSBR3340M** (500/carton)

HEAVY GRADE LINERS



- 45 Gallon, 40 x 48, 13 Micron gauge.
- Star seal bottom helps prevent leakage.
- High-density polyethylene offers superior film strength ideal for paper and non-sharp objects.
- Perforated for easy tear-off and dispensing convenience.
- 25 Bags/roll.
- White.

Item# **LAGJAGRH4048H** (10 rolls/ctn.)

SUPER/EXTRA HEAVY-GRADE CAN LINER



- 60 Gallon, 38 x 58, 1.3 Mil.
- Star seal bottom helps prevent leakage.
- Made from high-quality blended resins for superior strength and puncture resistance.
- Star seal bottom prevents leakage.
- Coreless rolls are perforated for easy dispensing.
- Gray "Granite."

Item# **LAGJAGRG3858G** (40 bags/case)

REPRO LOW-DENSITY CAN LINERS



- 38W x 58H.
- Thick, low-density polyethylene provides excellent puncture and tear resistance.
- Star-sealed bottom helps maximize total capacity while reducing the potential for leakage.
- Individually folded for easy dispensing.
- Black.

Item# **LAGJAGR3858H** (100 bags/box)

EXPERIENCE THE DIFFERENCE

Janitorial Supplies - Hand Cleaners

GOJO RICH PINK ANTIBACTERIAL LOTION SOAP REFILL



- SANITARY SEALED™, Bag-in-Box refills for PRO Series dispensers are easy to load, store and handle.
- A fresh dispensing valve with each refill ensures no leaks or clogs.
- Portion control dispensing can significantly reduce total cost per wash.
- High-performance, gentle antibacterial lotion soap.
- For cleaning light soils.
- 2 L bags.

Item# **LAGGOJ7220** (4 bags/carton)

GOJO NATURAL ORANGE PUMICE HAND CLEANER



- Orange citrus.
- Quick-acting lotion formula cleans a broad range of industrial soils, medium dirt and grease.
- Contains pumice scrubbing particles.
- Stock up and save!
- 1 Gallon pump.

Item# **LAGGOJ0955-04** (4 gal/carton)

LAVA HAND SOAP, UNSCENTED BAR



- Heavy-duty hand soap with pumice cleans dirty hands.
- Mild on skin.
- 4 Oz. bar.

Item# **LAGWDC10383** (48/case)

GOJO ORIGINAL FORMULA™ HAND CLEANER (CREME)



- Original GOJO creme formula contains lanolin and soothing emollients.
- Removes heavy grease, tar and oil.
- Can be used with or without water—rinse off or wipe clean with a towel.
- 4.5 Lb container.

Item# **LAGGOJ1111** (6 containers/case)

PROLINE SBS® LHS LOTION HAND SOAP



- A mild pink lotion soap with a silky smooth after feel.
- Ultrasonically sealed cartridges prevent ingress of bacteria.
- A gentle, all-purpose lotion soap.
- Properties – Contains PCMX to help fight infection causing bacteria.
- Rinses easily from the skin with no soapy residue.
- Controlled dispensing systems prevent waste.
- 4 Liter cartridge.

Item# **SBS06104** (4 units/case)

MISTY FROSTY PEARL HAND SOAP, MOISTURIZER



- Industrial hand and skin cleaner safely removes heavy soils such as grease, oil, paint and dirt without harsh solvents or rough abrasives.
- Contains lanolin, moisturizers and emollients for conditioning skin while it cleans.
- Frosty Pearl bouquet scent.
- 1 Gallon.

Item# **LAGAMRR915-4** (4 gallons/case)

SCRUBS IN-A-BUCKET HAND CLEANER TOWELS, CLOTH



- Heavy-duty, premoistened, textured towels have citrus-based cleaner that quickly dissolves dirt, paint, grease and grime.
- Towels lock in dirt and will not transfer soils back onto hands.
- Leaves hands clean; no rinsing necessary.
- 10-1/2 x 12-1/4, 72 towels/bucket.

Item# **LAGDYM42272** (6 buckets/case)

Janitorial Supplies - Cleaners and Disinfectants

SIMPLE GREEN ALL-PURPOSE INDUSTRIAL DEGREASER/CLEANER



- Concentrated; dilutes with water.
- Strong yet safe cleaner removes oil, lubricants and grime from washable surfaces.
- Rinses easily.
- For pressure washing and steam cleaning, maintenance.
- Safe for food-preparation areas.
- Exempt from OSHA and EPA special handling and personal protection requirements for hazardous materials.
- Biodegradable, nontoxic, nonabrasive and nonflammable.

Item# **LAGSMP13012** (24 Oz., 12/case)

Item# **LAGSMP13005** (1 Gal., 6/case)

Item# **LAGSMP13006** (5 Gal. Pail)

Item# **LAGSMP13008** (55 Gal. Drum)

409 CLEANER/DEGREASER



- Floral scent.
- Quickly removes grease, grime, food stains and other oil-based dirt from hard, nonporous surfaces.
- Powerful, ready-to-use formula has wide range of uses.
- 32 Oz. trigger spray bottles.

Item# **LAGCLO35306** (12 bottles/case)

Janitorial Supplies - Cleaners & Disinfectants

FABULOSO ALL-PURPOSE CLEANER



- Ocean cool scent.
- Cleans while leaving a long-lasting scent.
- No rinsing needed.
- Concentrate makes 64 gallons of ready-to-use solution.
- Biodegradable.
- 1 Gallon bottles.

Item# **LAGCPC04373** (4 bottles/carton)

MISTY BIODET ND-32



- Lemon scent.
- Germicidal detergent disinfects, cleans and deodorizes in one step.
- Kills staph, salmonella, pseudomonas, bacteria, viruses and fungus.
- Prevents growth of mold and mildew.
- Dilutes 1:32.
- 1 Gallon bottles.

Item# **LAGAMRR1220-4** (4 btl./case)

WINDEX AMMONIA-D® GLASS CLEANER



- Exclusive Ammonia-D® formula and special grease-cutting additives loosen soil on contact to remove dirt without streaking or filming.
- Also recommended for stainless steel, chrome, porcelain, ceramic tile and Formica® counters and tabletops.
- Phosphate-free.
- 32 Oz. trigger spray bottles.

Item# **LAGDRK90139** (12 bottles/case)

ULTRA CLOROX GERMICIDAL BLEACH



- Concentrated formula is ideal for sanitizing and disinfecting washrooms, shower stalls, toilets, food preparation areas and all nonporous surfaces.
- Effective against E. coli, HIV-1 (AIDS virus), salmonella, staph, TB and hepatitis A.
- Complies with OSHA Bloodborne Pathogens Standard.
- Meets FDA guidelines for sanitizing food-contact surfaces.
- A great all-around cleaner for a wide range of applications.
- 96 Oz. bottles.

Item# **LAGCLO02490** (6 bottles/case)

MISTY SUPER REPOSOLVE DETERGENT/DEGREASER



- Super-concentrated, noncorrosive formula is safe for use on most metals.
- Versatile product performs well when mixed with hot, cold or hard water.
- For use on machinery, metal, concrete, fabric and more. Works well in automatic scrubbing machines.
- Nonflammable and biodegradable.
- 1 Gallon bottles.

Item# **LAGAMRR327-4** (4 bottles/case)

PINE-SOL CLEANER DISINFECTANT DEODORIZER, FRESH SCENT



- All-purpose cleaner and disinfectant.
- Kills germs, including Salmonella enterica, Staphylococcus aureus, Trichophyton mentagrophytes (Athlete's Foot Fungus) and Influenza A virus.
- Removes tough grease and dirt.
- 144 Oz. bottles.

Item# **LAGCLO35418** (3 btl./carton)

AJAX ALL-PURPOSE LIQUID CLEANER



- Lemon scent.
- Removes tough dirt and grease and leaves surfaces sparkling clean.
- 32 Oz. bottles.

Item# **LAGCPC41197** (12 bottles/case)

DAWN DISHWASHING LIQUID



- Cuts through the toughest grease and leaves pleasant original scent.
- Stock up and save!

Item# **LAGPGC02613-GL** (1 Gal., 3/ctn)

Item# **LAGPGC45112** (38 Oz., 8/ctn)

DIAL BODY & HAIR SHAMPOO



- PH-balanced formula cleanses entire body.
- Gender-neutral fragrance (peach scent); perfect for fitness clubs, spas and nursing homes.
- Keeps hair shiny and soft.
- Added conditioners leave skin soft and smooth.
- Color: Clear amber.
- 1 Liter cartridge.

Item# **LAGDIA04029** (8 cartridges/case)

MISTY FURNITURE POLISH FOR WOOD



- Citrus scent.
- Dust and clean while you give your furniture a deep rich luster that lasts.
- Handy product removes old wax build-up and fills minor scratches and nicks at the same time.
- Cleans wood, leather, vinyl and other fine-quality surfaces.
- 20 Oz. aerosol can.

Item# **LAGAMRA134-20** (12 cans/case)

Janitorial Supplies - Cleaners & Disinfectants

MISTY HOSPITAL DISINFECTANT & DEODORANT



- This hospital disinfectant with a phenol-based formula can disinfect HIV, TB, Herpes I and II, as well as the hospital trio, and control residual mold and mildew (up to seven days on hard surfaces, 28 days on fabrics).
- Formula leaves a fresh, clean scent.
- Great for performing powerful disinfecting on a wide range of surfaces such as refuse cans, toilet seats, telephones and door knobs.
- Features a 360 degree valve to spray formula in any direction.
- 16.5 Oz. aerosol can.

Item# **LAGAMRA221-20** (12 cans/case)

MISTY DUST MOP TREATMENT



- Pine scent.
- An excellent alternative to sweeping compounds for dust-mopping and push-broom-sweeping tasks.
- Effectively coats floor, minimizing the potential for messy dust cloud formation.
- Contains no wax or silicone.
- Will not damage or make treated surfaces slippery.
- 20 Oz. aerosol can.

Item# **LAGAMRA810-20** (12 cans/case)

BOARDWALK DUST MOP TREATMENT



- Eliminates dust created when using push brooms.
- Use on dust mops to replace sweeping compounds.
- Will not damage floor or make floor slippery when sprayed lightly.
- Can be used to dust asphalt tile, linoleum, vinyl, asbestos, rubber, marble, ceramic, concrete, quarry tile, magnesite, cork and wood floors.
- 18 Oz. aerosol can.

Item# **LAGBWK352A** (12 cans/case)

Janitorial Supplies - Sponges

ZEPHYR SMOKE SPONGES



- Specially formulated latex rubber sponge cleans with or without water.
- Use without water on wallpaper, ceilings, painted walls, wood paneling, window shades, tapestry and felt.
- Can be washed and reused.
- Use with water on autos, upholstery, carpets, woodwork, floors, awnings or as a bath sponge.
- Good for removing pet hair.

Item# **ZEP563410** (3/4" x 3" x 6")

Item# **ZEP56139** (1-1/2" x 3" x 9")

Janitorial Supplies - Floor Pads

FLOOR STRIPPING PADS, BLACK



Standard (5 pads/case)

- Ideal for wood floors.
- For heavy-duty floor stripping.

Item# **LAGPAD4017 BLA** (17" Dia.)

Item# **LAGPAD4018 BLA** (18" Dia.)

Heavy-Duty (5 pads/case)

- For use with machine speeds of 175 to 350 RPM.

Item# **LAGPAD4020 BLA** (20" Dia.)

MICROFIBER WET FLOOR CLEANING PAD, BLUE



- Split nylon/polyester blend.
- Proven to remove 99.9% of microorganisms.
- Scrubbing strips for cleaning tough stains.
- Reduces water, chemical consumption up to 90%.
- Helps reduce cross-transmissions.
- Bleach safe / Durable up to 500 launderings.
- Size: 18".

Item# **LAGRCPQ410 BLU** (12/carton)

Janitorial Supplies - Floor Care

STANDARD MICROFIBER DAMP MOPPING PAD



- Premium split nylon/polyester blend microfiber provides optimal wet mopping performance.
- Dense 3 - 5 micrometer quality fiber removes more dust, dirt and microbes than conventional cleaning products.
- Size: 18" x 5" x 1/2".

Item# **RCPQ409-20**

CUT-END WET MOP HEAD, COTTON



- Clean up quicker with a high-quality, ultra-absorbent mop head.
- Cut-end design minimizes snags.
- Heavy-duty headband ensures secure attachment.
- For use with clamp-style mop handles.
- Color: White.

Item# **LAGUNS2024C** (#24)

Item# **LAGUNS2032C** (#32)

WAVEBRAKE 35-QUART BUCKET/WRINGER COMBINATION



- Molded-in wave baffles.
- Heavy-duty, ergonomic wringer designed to exceed 50,000 cycles.
- Mop handle secures during transport.
- Nonmarking 3" casters.
- Constructed of tubular steel and structural web molded plastic.
- For general mopping jobs.
- Accepts Dirty Water Bucket (sold separately).
- 18% Less effort to wring mop.
- For 12- to 32-oz. mop heads.

Item# **LAGRCP7580-88 YEL**

Janitorial Supplies - Floor Care

MAID BROOM, MIXED FIBER BRISTLES



- For light-duty sweeping.
- Five rows of stitching.
- Lacquered wood handle.
- 42" Wood handle.
- Color: Natural.

Item# **LAGUNS920Y** (12/case)

WHISK BROOM, CORN FIBER BRISTLES



- For general spot cleaning.
- Corn bristle fibers with three rows of stitching for added strength and durability.
- Metal cap and ring for easy hanging.
- 10" Wood handle.

Item# **LAGUNS951WC** (12/case)

NO. 22 LINE GARAGE BRUSH W/HANDLE



- Coarse brown plastic.
- Staple set in clear lacquered hardwood block.
- For wet or dry sweeping rough concrete or asphalt floors such as in service station driveways, creamery and packing house floors.
- Will not soften when exposed to water, oils or greases.
- Length of Trim: 3 inches.

Item# **MGB2224** (24" Broom)

NO. 14 LINE GARAGE BRUSH W/HANDLE



- Prime stiff Palmyra fiber.
- Staple set in clear lacquered streamlined hardwood block.
- For wet or dry sweeping under rough conditions such as wet and greasy concrete floors in service stations, packing houses, creameries, etc.
- Length of Trim: 4 inches.

Item# **MGB1424** (24" Broom)

NO. 20 LINE FLOOR BRUSH W/HANDLE (ECONOMY)



- Black plastic bristles.
- Staple set in clear lacquered half-round hardwood block.
- For wet or dry sweeping rough or semi-smooth concrete, wood, asphalt, etc.
- Length of Trim: 3 inches.

Item# **MGB2024SL** (24" Broom)

CURVED SQUEEGEE W/ STEEL BRACKET HANDLE, HEAVY-DUTY



- Squeegee frame is made of 1" angle aluminum to which a 2" wide x 1/4" thick strip of high-grade flexible black squeegee rubber or neoprene is attached with cadmium plated screws.

Item# **MGB4624** (24" Squeegee)

STRAIGHT SQUEEGEE W/ STEEL BRACKET HANDLE, HEAVY-DUTY

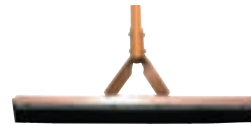

- Squeegee frame is made of 1" angle aluminum to which a 2" wide x 1/4" thick strip of high-grade flexible black squeegee rubber or neoprene is attached with cadmium plated screws.

Item# **MGB4124** (24" Squeegee)

METAL TIP THREADED HARDWOOD BROOM HANDLE



- Die-cast, unbreakable aluminum threaded tip secured to natural lacquered hardwood handle.
- Smooth grip.
- 1" Diameter, 60" Long.

Item# **LAGBWK136**

CLIP-ON DUST MOP HANDLE



- Snaps onto UNISAN Clip-On Dust Mop Frame (sold separately) from standing position.
- 12-gauge zinc-plated steel hardware.
- 180° swivel head w/ sliding nylon lock.
- Double-lacquered wood handle.
- 1" Diameter, 60" Long.

Item# **LAGUNS1490**

UTILITY PAD HOLDER



- Full-range, 360° swivel connector helps simplify scrubbing tough, hard-to-reach areas.
- Strip-resistant die-cut threaded socket accommodates all standard, threaded mop handles.
- Pad-locking tines – secure attachment.
- 10"W x 4"D, Gray.

Item# **LAGPAD405**

DISPOSABLE DUST MOP HEAD, COTTON/SYNTHETIC



- Four-ply, pretreated yarns. Open synthetic backing with ties.
- Sewn center fringe for added coverage.
- Handle/frame sold separately.
- 24"W x 5"D, White.

Item# **LAGUNS1624**

INDUSTRIAL DUST MOP HEAD, HYGRADE COTTON



- Four-ply, cut-end.
- Launder in mesh bag.
- Keyhole style, half-tie synthetic backing dries fast.
- Handle/frame sold separately.
- 36"W x 5"D, White.

Item# **LAGUNS1336**

Janitorial Supplies - Miscellaneous

9-1/2" STANDARD TRIGGER SPRAYER, 24 PER CARTON



- Fits 32-oz. bottle.
- Item# **LAGUNS5910-9** (24/carton)

PLASTIC BOTTLE, NATURAL



- Mix and dispense concentrated cleaning products.
 - Bottle is marked with quantity graduations.
 - Size: 32 Oz.
- Item# **LAGUNS32** (24/carton)

POLYETHYLENE SIPHON PUMP



- This sturdy, polyethylene siphon drum pump works with 15-, 30- and 55-gallon drums.
- Item# **LAGUNS423**

ECONOMY SILICONE



- Light-duty silicone restores, lubricates and protects rubber, plastic and vinyl.
 - Also, used to reduce friction on sewing needles, knives and cutters.
 - Will not freeze or melt or be effected by oil or water.
- Item# **LAGAMRA324-16** (12 cans/case)

RELY-ON OLEFIN INDOOR WIPER MAT

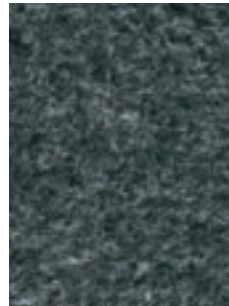

- Economical continuous filament olefin on standard vinyl is ideal for light to medium traffic.
- Plush surface dries moisture from shoes – holds up to 3/4 gallon of water per square yard.
- Gentle, color-blend pattern complements any décor.
- Size: 36" x 60".
- Color: Charcoal.

Item# **LAGCROGS35CHA**

BOX SEALING TAPE



- Size: 2" x 60 Yd.
- Item# **LAGMCO375026OCR**

SHOE HANDLE WIRE SCRATCH BRUSH



- Filling material is staple set in a smooth wax tumbled hardwood block.
- Block Size: 10"L x 1"W.
- Length of Trim: 1-1/8".
- No. of rows: 4 x 16.

Item# **BRSEC4S**

CURVED HANDLE WIRE SCRATCH BRUSH



- Round Carbon Steel Wire.
- Staple set in a smooth wax tumbled hardwood block.
- Block Size: 14"L x 1"W.
- Length of Trim: 1-1/8".
- No. of rows: 3 x 19.

Item# **BRS319CS**

HANDY CLEANING BRUSH



- Filling material is staple set in toothbrush-style plastic handle.
- This brush is designed for general cleaning in the metal plating and finishing industries.
- Also, for cleaning of small parts, seams and soldered joints in the aeronautics and electronics industries.
- Block Size: 7"L x 7/16"W.
- Length of Trim: 1/2".

Item# **BRS274**

Abatix' online ordering system is simple to use. Once you are registered and have a customer code, you can create orders, customize shopping lists, and view ordering history, track shipments, view and print invoices and pay bills online. Head over to www.abatix.com and start shopping today.

Ladders

FIBERGLASS STEPLADDERS



FS1500 Series

- ProTop™ - versatile and durable.
- Da Boot™ slip resistant footing Patent #7,000,731 B2.
- Shox™ impact absorption system.
- Inside spreader braces.
- Double-rivet step construction.
- Wide back braces.

A multifunctional top designed to increase productivity.

- **HARDWARE TRAY**
Recessed tray provides area to secure hardware from falling off the top.
- **PAINT BUCKET Holder**
Convenient recessed tray holds quarter/half/full gallon paint buckets.
- **DRILL SLOTS**
Two separate drill slots make for a variety of convenient options especially when also using the paint bucket holder.
- **SCREWDRIVERS/PLIERS**
Featuring plenty of slots, ProTop™ will hold all the tools needed.
- **CURVED FRONT**
Curved surface on front of top helps provide leg comfort.
- **PIPE & 2X4 HOLDER**
Groove across top keeps pipes and 2x4's from getting away from you.
- **MAGNET TRAY**
Easily secures metallic hardware and tools. Not available on type II ladders.



FM1500 Twin Front Series



- Da Boot™ slip resistant footing, Patent #7,000,731 B2.
- Inside spreader braces.
- Double-rivet step construction.
- Heavy gauge steel hinges.
- Shox™ impact absorption system.

Item#	Ladder Size	Step Size	Bottom Width	Approx. Spread	Approx. Wt. (lbs.)	Approx. Cubes
LOUFS1503	3'	3"	18-1/16"	23"	12	2.6'
LOUFS1504	4'	3"	19-9/16"	28-15/16"	14	3.6'
LOUFS1505	5'	3"	21-1/16"	34-7/8"	17	4.9'
LOUFS1506	6'	3"	22-9/16"	40-7/8"	20	5.7'
LOUFS1507	7'	3"	24-1/16"	46-13/16"	22	7.9'
LOUFS1508	8'	3"	25-9/16"	52-3/4"	26	8.7'
LOUFS1510	10'	3"	28-9/16"	64-11/16"	34	10.9'
LOUFS1512	12'	3"	31-9/16"	76-1/16"	47	15.8'



TWIN FRONT LADDER						
Item#	Ladder Size	Step Size	Bottom Width	Approx. Spread	Approx. Wt. (lbs.)	Approx. Cubes
LOUFM1503	3'	3"	18-1/16"	30-1/8"	16	3.4'
LOUFM1504	4'	3"	19-9/16"	37-1/2"	19	4.9'
LOUFM1505	5'	3"	21-1/16"	44-7/8"	22	6.5'
LOUFM1506	6'	3"	22-9/16"	52-5/16"	27	8.4'
LOUFM1507	7'	3"	24-1/16"	59-11/16"	30	10.2'
LOUFM1508	8'	3"	25-9/16"	67-1/8"	34	12.3'
LOUFM1510	10'	3"	28-9/16"	81-15/16"	44	17.3'
LOUFM1512	12'	3"	31-9/16"	96-3/4"	62	23.1'

BOTH SIDES of twin front ladders can be used simultaneously by one person plus materials. Therefore the duty rating for this ladder is PER SIDE.



EXPERIENCE THE DIFFERENCE

Ladders

FIBERGLASS EXTENSION LADDERS

- QuickLatch® Patent # 15429207.
- Steel swivel safety shoe w/metal shield.
- Outside slide guides.
- D-shaped rungs.
- Mar-resistant rail end caps.



FE3200 Series

FE3100 Series

FE8800 Series

Manhole Ladder

- Utility-style safety shoes.
- Round rungs.
- Convenient 14" width design.
- Rail protectors.



COMBINATION POLE GRIP & CABLE HOOK

A rigid plated steel V-shaped pole grip covered with rubber tread, combined with cable hook assembly.

Item# LOUE03

TWO SECTION EXTENSION LADDERS					
Item#	Total Length	Length Each Section	Max Ex. Length	Approx. Wt. (lbs.)	Approx. Cubes
LOUFE3216*	16'	8'	13'	30	6.5'
LOUFE3220	20'	10'	17'	42	8.6'
LOUFE3224	24'	12'	21'	52	10.2'
LOUFE3228	28'	14'	25'	58	11.9'
LOUFE3232	32'	16'	29'	70	12.6'
LOUFE3236	36'	18'	32'	79	15.8'
LOUFE3240	40'	20'	35'	93	17.5'

*Does not include rope and pulley.

SINGLE LADDERS (Trenching Ladder)			
Item#	Total Length	Approx. Wt. (lbs.)	Approx. Cubes
LOUFE3108	8'	16	3'
LOUFE3110	10'	21	5.3'
LOUFE3112	12'	25	4.8'
LOUFE3114	14'	28	5.6'
LOUFE3116	16'	36	6.7'
LOUFE3118	18'	41	7.5'



SINGLE LADDERS (Manhole Ladder)			
Item#	Total Length	Approx. Wt. (lbs.)	Approx. Cubes
LOUFE8808	8'	19	2.5'
LOUFE8810	10'	23	3.2'
LOUFE8812	12'	25	3.8'
LOUFE8814	14'	30	4.4'
LOUFE8816	16'	36	5'
LOUFE8818	18'	41	5.7'
LOUFE8820	20'	45	6.3'





Locks - Padlocks, Cables & Hasps

Heavy-Duty Cables

- 4' (1.2m) Long x 3/8" (10mm) Diameter looped end cable.
- Ideal for securing large or bulky items.
- Braided steel for superior strength and flexibility.
- Protective vinyl coating helps prevent scratching.
- Recommend for use with laminated locks, solid steel locks and mini-U-locks.



Product Number	Description
MAS85DPF	4' (1.2m) long, 3/8" (10mm) diameter cable

No. 40 Shrouded Padlock

- Fully shrouded design minimizes shackle exposure and protects against bolt cutter attacks.
- 2-3/4" (70mm) Wide stainless steel lock body resists corrosion.
- Hardened steel shackle for extra cut resistance.
- Double deadbolt locking for superior pry resistance.
- 4-Pin cylinder helps prevent picking.
- Key retaining feature ensures padlock is not left unlocked.



Product Number	Description
MAS40KADPF	Keyed alike

Hidden Shackle Padlock

- ProSeries® Padlocks are designed for Commercial/Industrial applications.
- Lock body conceals shackle – defeats attempts to pry and cut.
- 2-7/8" (73mm) Wide hardened solid steel body withstands forcible attacks.
- 3/8" (9mm) Diameter boron alloy shackle.
- High security, rekeyable 6-pin cylinder with spool pins is virtually impossible to pick.



Product Number	Description
MAS6270	Keyed Different; 6-pin W7000 cylinder; 2-7/8" (73mm) wide body

No. 770 Solid Steel Hasp

- Ideal for vans, trucks, gates and vending.
- 9" (23cm) Wide x 4-1/2" (11cm) High hardened solid steel hasp withstands forcible attacks.
- Defeats attempts to pry and cut.
- Designed for use with Nos. 6270 and 6271 hidden shackle locks.



Product Number	Description
MAS770	Solid Steel Hasp for use with No. 6270 lock; 9" (23cm) wide x 4-1/2" (11cm) high

No. 175 Combination Padlock

- Set-your-own 4-digit combination for convenience and security.
- Reset to any of 10,000 personalized combination.
- 2" (51mm) Wide solid brass case for strength and weatherability.
- 1" (25mm) Hardened steel shackle for cut resistance.



Product Number	Description
MAS175	Set-Your-Own combination

No. 178 Combination Padlock

- Black powder-coat, 2" (51mm) Wide die cast body for durable security and weatherability.
- Set-your-own 4-digit combination for convenience and security.
- Reset to any of 10,000 personalized combination.
- 1" (25mm) Hardened steel shackle for cut resistance.



Product Number	Description
MAS178BLK	Set-Your-Own combination; black

No. 1 Laminated Padlock

- Commercial grade padlock features superior protection from drilling and prying.
- 1-3/4" (44mm) Wide laminated steel body for superior strength.
- 15/16" (24mm) Tall, 5/16" (8mm) Diameter hardened steel shackle for superior cut resistance.
- Dual locking levers provide extra pry resistance.
- Non-rekeyable, 4-pin W1 cylinder helps prevent picking.



Product Number	Description
MAS1KA	Keyed Alike

No. 3 Laminated Padlock

- Commercial grade padlock features superior protection from drilling and prying.
- 1-9/16" (40mm) Wide laminated steel body for superior strength.
- 3/4" (19mm) Tall, 9/32" (7mm) Diameter hardened steel shackle for superior cut resistance.
- Dual locking levers provide extra pry resistance.
- Non-rekeyable, 4-pin W1 cylinder helps prevent picking.



Product Number	Description
MAS3KA	Keyed Alike

EXPERIENCE THE DIFFERENCE

Locks - Padlocks & Lockout

No. 5 Padlock

- Commercial grade padlock features superior protection from drilling and prying.
- 2" (51mm) Wide laminated steel body for superior strength.
- 1" (25mm) Tall, 3/8" (10mm) Diameter hardened boron alloy shackle for superior cut resistance.
- Dual locking levers provide extra pry resistance.
- Non-rekeyable, 4-pin W1 cylinder helps prevent picking.



Product Number	Description
MAS5KA	Keyed Alike

Weather Tough Padlocks

- Body and cylinder covers protect from water, dirt and grime.
- Hardened boron alloy shackle for superior cut resistance.
- Heavy steel bodies withstand forcible attacks.
- Chrome rustproofing provides longer life.
- 16 interchangeable core keyways including Best®, Arrow®, Falcon® and Master Lock®.



Product Number	Description
MAS6421WO	2-1/8" (54mm) wide body
MAS6421LJWO	2-1/8" (54mm) wide body; long shackle

Personal Lockout Kit – Value and Electrical (Laminated Steel Locks)

- A S1017 safety carry case containing:
 - (3) No. 3RED laminated steel padlocks, keyed alike
 - (1) 7C5RED Circuit breaker padlock
 - (1) 420 Lockout hasp
 - (1) 427 Snap-on red hasp
 - (1) S806 Adjustable cable lockout
 - (1) 480 Gate valve cover for 1" to 3" handles
 - (1) 481 Gate valve cover for 2" to 5" handles
 - (1) 482 Gate valve cover for 4" to 6.5" handles
 - (1) 468L Seal Tight ball valve lockout
 - (1) S3068 ball valve lockout
 - (2) 491B Grip Tight lockout devices for wide or tall breaker toggles
 - (3) 493B Grip Tight lockout devices for standard size breaker toggles
 - (1) 496B Universal wall switch cover toggle and paddle switch
 - (1) Bag of 12-497A Danger Tags.

Product Number	Description
MAS1457VE3KA	Personal Lockout Kit – value and electrical

Master Lock

410 Government Padlocks

- Designed exclusively for Lockout/Tagout applications.
- Durable, lightweight, non-conductive Xenoy lock body.
- Customize on-site with permanent, write-on labels.
- Compliance with OSHA "one employee, one lock, one key" directive.
- High security, reserved-for-safety cylinder.
- Key retaining – ensures that padlock is not left unlocked.
- Keyed different 6-pin tumbler cylinder.



Product Number	Description
MAS410RED	1-1/2" (3.8cm) wide, 1-3/4" 4.4cm tall, red body
MAS410YWL	1-1/2" (3.8cm) wide, 1-3/4" 4.4cm tall, yellow body
MAS410LTRED	1-1/2" (3.8cm) wide, long shackle, red body

Safety Lockout Hasp – 1" Jaw

- Lockout by multiple workers at each lockout point.
- Keeps equipment inoperative while repairs or adjustments are made.
- Control cannot be turned on until last worker's padlock is removed from hasp.
- Heavy gauge steel jaw with red vinyl coated handle.
- Dimensions are 1-3/4" x 4-1/2" with 1" inside jaw diameter, holds up to 6 padlocks.



Product Number	Description
MAS420	Steel Lockout Hasp, 1" jaw



Material Handling

6 CU. FT. STEEL WHEELBARROW



Get more done with this hard-working True Temper® wheelbarrow. The high-capacity 6 cubic-foot steel tray, rugged steel handles and flat-free tire make this unit ideal for just about any job. This wheelbarrow is built to last and will provide years of trouble-free service.

Features

- 6 Cubic foot capacity.
- 16" Flat-free tire, never needs air.
- Tough steel handles w/comfort grips. / Heavy-duty undercarriage.

Item# **AMEC6STFF**

Item# **AMEFFTCC** (Replacement Tire)

1.1 CU. YD. STANDARD DUTY TILT TRUCK



Features

- 1.1 Cubic yard, 800 lb., 222 gal. capacity.
- Industrial plastic with steel tubing frame.
- (2) 12" rubber wheels.
- (2) 5" swivel rubber casters.
- 23.7 bu., 72-1/2" x 33-1/2" x 39-1/2".
- Black with black frame.

Item# **CON5833BK**

RUBBERMAID COMMERCIAL PRODUCTS HEAVY-DUTY, 2-SHELF UTILITY CART W/LIPPED SHELF



Perfect for transporting materials, supplies, and heavy loads in almost any environment.

- Ergonomically designed push handle provides optimum hand placement and push height improving control and worker safety.
- Molded-in storage compartments, holsters, hooks, and notches.
- Molded-in customizable fittings.
- High density structural resin construction.
- Easy-access bottom shelf.
- Best-in-class casters to meet the most demanding environments.

Item# **LAGRCP4520-88 BLK**

RUBBERMAID COMMERCIAL PRODUCTS TILT TRUCK, UTILITY DUTY (ROTATIONAL MOLDED)



Industrial strength construction transports heavy loads with ease.

- 1/2 Cu. yd. capacity.
- Easy to handle and maneuver through commercial doorways and onto elevators.
- Constant force design allows for controlled dumping by one person.
- Inset wheels protect walls, fixtures and patrons.
- Smooth surface is easy to clean and resists pitting and corroding.

Item# **LAGRCP1304BLA**

HAZMAT BOXES



Features

- One piece carton with flaps for easy assembly and handling.
- Capacity: Four 55-Gallon drums or one ton (2,000 lbs).
- UN Regulated Packaging: 11G/Y/S.
- Size: 36" x 36" x 36" I.D.
- 6.5 mil poly liner.
- Are cost-saving alternatives to drums.
- Have weather resistant coating.
- Are stackable two boxes high.

Item# **EPCEP3**

EXPERIENCE THE DIFFERENCE

Material Handling - Winches, Hoists & Chains

Maasdam® Cable Pullers

Features:

- 1-Piece, aluminum alloy ratchet wheel.
- High strength, electro-plated steel parts.
- "Notch-at-a-time" letdown.
- Drop forged steel slip hooks.
- Non-slip plastic grip.
- OSHA recommended safety latches.
- Uses galvanized, aircraft quality cable.



Specifications

Part No.	Capacity	Max. Lift	Cable Dia.	Leverage	Shipping Weight
144SB-6	2Ton	6'	3/16"	30:1	8 lbs. 12 oz.
<i>(metric)</i>	<i>(1814kg)</i>	<i>(1.83m)</i>	<i>(4.762mm)</i>	<i>(30:1)</i>	<i>(3.969kg)</i>

Aircraft Cable Ratings (based on military specs) (7" x 19" galvanized aircraft cable)

Cable Diameter	Minimum Breaking Strength Tested
3/16 in. (4.762mm)	4200 lbs. (1905.1kg)
5/32 in. (3.969mm)	2800 lbs. (1270.1kg)
1/8 in. (3.175mm)	2000 lbs. (907.2kg)

Conversions

lbs. to kg	.4536	in. to mm	25.40
ft. to m	.3048	oz. to kg	.02835

Bravo® Lever Hoist

Strong

- ◆ The hoist and its components are made of high tensile alloy steel.
- ◆ Excellent weight / capacity / size ratio.

Safe

- ◆ 360° Swivel hook with overload opening indicators.
- ◆ Removable safety catches marked with WLL of the hoist.
- ◆ 5-Sprocket load wheel with closed bearings.
- ◆ Free wheel safety device activates braking mechanism when load applied in neutral position.

Other features

- ◆ Light and portable / Easy to operate.
- ◆ Single hand operation to put in neutral.
- ◆ Continuous 360° rotation axis lever.
- ◆ Anti-slip lever handle.
- ◆ Load chain meets or exceeds ANSI standards.
- ◆ High performance gears.
- ◆ Meets ANSI B30.21C, Manually Lever-Operated Hoist code.

Specifications

Item No.	Rated Load	Capacity	Stand. Lifting Height	No. of Falls	Load Chain Size	Effort on Lever at Capacity	Weight
19669	0.75 ton	1500 lbs. (750kg)	5 ft. (1.5m)	1	6 x 18mm	44 lbs. (20kg)	15 lbs. (7kg)
19670	0.75 ton	1500 lbs. (750kg)	10 ft. (3m)	1	6 x 18mm	44 lbs. (20kg)	17 lbs. (8kg)
19679	1.5 ton	3000 lbs. (1500kg)	5 ft. (1.5m)	1	7 x 21mm	46 lbs. (21kg)	26 lbs. (12kg)
19680	1.5 ton	3000 lbs. (1500kg)	10 ft. (3m)	1	7 x 21mm	46 lbs. (21kg)	30 lbs. (14kg)
19689	3.0 ton	6000 lbs. (3000kg)	5 ft. (1.5m)	1	10 x 30mm	73 lbs. (33kg)	44 lbs. (20kg)
19690	3.0 ton	6000 lbs. (3000kg)	10 ft. (3m)	1	10 x 30mm	73 lbs. (33kg)	51 lbs. (23kg)



Material Handling

Binder Chains – Grade 70



- A complete line of tie down chains.
- All chains listed may be used in accordance with the latest D.O.T. regulations.
- Yellow chromated zinc electroplated finish.
- All binders have a forged heat treated clevis grab hook on each end.
- **Do not use for overhead lifting.**



Campbell®

Size	With Clevis Grab Hooks Cat. No.	UPC No. 020418	Std. Pkg.	Weight Each	Working Load Limit
5/16" x 14' (8mm x 4.3m)	0513571	174162	25	15 lbs. (7kg)	4,700 lbs. (2,130kg)
5/16" x 16' (8mm x 4.9m)	0513572	174179	25	17 lbs. (8kg)	4,700 lbs. (2,130kg)
5/16" x 20' (8mm x 6.1m)	0513574	174193	25	24 lbs. (11kg)	4,700 lbs. (2,130kg)
5/16" x 25' (8mm x 7.6m)	0513575	174209	25	30 lbs. (14kg)	4,700 lbs. (2,130kg)
3/8" x 14' (10mm x 4.3m)	0513658	064128	25	24 lbs. (11kg)	6,600 lbs. (2,990kg)
3/8" x 16' (10mm x 4.9m)	0513660	064135	25	27 lbs. (12kg)	6,600 lbs. (2,990kg)
3/8" x 20' (10mm x 6.1m)	0513665	064159	20	32 lbs. (15kg)	6,600 lbs. (2,990kg)
3/8" x 25' (10mm x 7.6m)	0513667	064166	20	39 lbs. (18kg)	6,600 lbs. (2,990kg)
1/2" x 20' (13mm x 6.1m)	0513765	178788	20	54 lbs. (24kg)	11,300 lbs. (5,130kg)

WARNING

To prevent the possibility of serious bodily injury:

- **DO NOT EXCEED** the working load limits for chain or components.
- **DO NOT USE** for overhead lifting or hoisting.
- **DO NOT USE** if the chain or components are visibly distorted or worn.

Material Handling - Slings & Straps

Polyester Webbing – Polyester is used mainly where acid conditions are present or a minimum stretch is desired. It is unaffected by common acids and hot bleaching agents. It is not suitable for use with concentrated sulfuric acid, alkaline or at temperatures in excess of 190°F (90°C). Stretch at rated capacity is approximately 3% (untreated).



POLYESTER WEB SLINGS

Eye & Eye Flat (Type 3)



Rated Capacity in Pounds

Stock No.	Width	Length	Ply	Vertical	Choker	Basket	60°	45°	30°	Eye Length	Eye Width
EE2-901-4	1"	4'	2	3,200	2,500	6,400	5,500	4,500	3,200	8"	1"
EE2-902-4	2"	4'	2	6,400	5,000	12,800	11,100	9,000	6,400	10"	2"
EE2-902-6	2"	6'	2	6,400	5,000	12,800	11,100	9,000	6,400	10"	2"
EE2-902-8	2"	8'	2	6,400	5,000	12,800	11,100	9,000	6,400	10"	2"
EE2-902-10	2"	10'	2	6,400	5,000	12,800	11,100	9,000	6,400	10"	2"
EE2-902-20	2"	20'	2	6,400	5,000	12,800	11,100	9,000	6,400	10"	2"
EE2-903-10	3"	10'	2	8,900	7,200	17,800	15,400	12,600	8,900	11"	1.5"
EE2-903-20	3"	20'	2	8,900	7,200	17,800	15,400	12,600	8,900	11"	1.5"
EE2-904-16	4"	16'	2	12,000	9,600	24,000	20,800	17,000	12,000	12"	2"
EE2-904-20	4"	20'	2	12,000	9,600	24,000	20,800	17,000	12,000	12"	2"

RATCHET STRAP ASSEMBLIES

**3,000 lb. Series
1" Heavy-Duty Webbing**

Versatile Ratchet Assemblies that are perfect for tying down light loads on trucks and a variety of other general cargo restraint applications.



End Fittings	Stock No.	Strap Width	Strap Length	Working Load Limit
With Wire Hooks and Keeper* (HK)	30R15HK	1"	15'	1,000 lbs.
With Vinyl Coated S-Hooks	30R15VS	1"	15'	1,000 lbs.

*The wire hook and keeper allow for three varieties of attachments: 1) Use wire hook to secure to edge of trailer; 2) Use keeper ring to attach or fasten to anchor point; 3) Use hook and keeper to form a wrap around loop.

**10,000 lb. Series
2" Webbing with Long Wide Handle**

Heavy-duty Ratchet Assemblies are used to tie down loads on flatbed trailers, trucks and for many other cargo restraint applications.

- Ratchet Features:**
- Patented 1-piece handle and double locking mechanism.

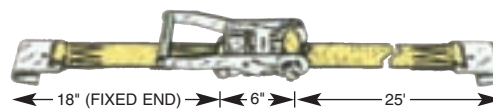

End Fittings	Stock No.	Strap Width	Strap Length	Working Load Limit
With Flat Hooks (FH)	10P27FH	2"	27'	3,335 lbs.



Material Handling

EXPERIENCE THE DIFFERENCE

Material Handling

PIONEER™ PALLET TRUCK

For the day-to-day movement of loads.



Features

- Rated Load: 5,500 lbs. (2500kg).
- Fork Length: 48" (122cm).
- Overall Width: 27" (68.6cm).
- Minimum Height: 2.875" (74mm).
- The steering wheels and fork rollers have a polyurethane tread giving a good load capacity and requiring minimum effort to move.
- The hydraulic pump control lever has three positions (lift - neutral - lower) and is well protected inside the rounded handle of the steering column which automatically returns to the vertical when released.
- Mechanical stop to protect the pump from overloading.
- The complete frame is protected by a double coating of acrylic paint applied after sand blast treatment.

Advantages

- Pioneer pallet trucks are strong, safe and easy to use.
- Control lever with three positions (lift, neutral, lower).
- P.U. (polyurethane) steering wheels and rollers requiring minimum effort to move.
- Bearing greased for life.
- High duty hydraulic pump with chromium-plated piston.

Item# **TRA33009**

FURNITURE BLOCKS



- Size: 2" x 2".
- No crumbs. High density for minimum crush.
- Tough, 1-inch thick blue Styrofoam® snap blocks.
- The toughest blocks you'll ever use.

Item# **MDP2X2SNAPBLOCK**

JUSTRITE SURE-GRIP® EX SAFETY CABINET



(Lock is optional)

Yellow Safety Cabinet for Flammables

Protect workers, reduce fire risks, and improve productivity by storing hazardous liquids in high performance Sure-Grip® EX safety cabinets. Designed to meet OSHA and NFPA standards, cabinets are sturdily constructed of all-welded, 18-gauge (1mm), double-walled steel with 1.5" (38mm) of insulating air space for fire resistance. Fail-safe, 3-point self-latching system provides easy, positive door closure. Three durable stainless steel bullet latches offer optimum longevity with increased heat resistance.

Features

- Capacity: 30 gal. (114 L).
- Exterior Dimensions: 44" x 43" x 18" (1118 x 1092 x 457mm).
- One shelf (adjustable).
- U-Loc™ Padlockable Handle is supplied with two keys and accepts an optional No. 5 Master Lock® padlock for added security.
- Haz-Alert™ Reflective Labeling. When illuminated by a flashlight beam, hazardous warning labels burst with high visibility under fire conditions or power outages.
- Sturdy galvanized steel SpillSlope™ Shelves safely direct incidental spills to back and bottom of leak proof sump. Adjustable on 3" (76mm) centers, they meet ANSI standards with a 350 lb. (159kg) safe allowable load.
- Other extras include rounded safety door corners to reduce accidental nicks or cuts, 2" (51mm) leak tight sump, dual vents with flame arresters, four adjustable leveling feet, grounding connector, and hazard warning in three languages. Fully painted inside-and-out with a durable, lead-free hybrid powder paint for chemical resistance, each cabinet is backed by a Ten-Year Warranty.
- Meets OSHA 29 CFR 1910.106 and NFPA Code 30 and is FM Approved. Shelves meet ANSI MH28.1.

Item# **JUS893000**

Don't see what you are looking for? Ask your Abatix Sales Representative. Abatix carries tens of thousands of products. We will make sure you get what you need, when you need it, where you need it.

Material Handling - Safety Cans - Type I



Compliant and economical Justrite Type I safety cans reduce fire risks and make everyday use of flammables easier and safer. The self-venting, self-closing leakproof lid prevents ruptures from pressure build-up and controls vapors and spills. Made of galvanized steel with a tough powder paint finish, can capacities 1 gallon and above have ample headspace to accommodate oil additives.



Stainless Steel Flame Arrester

- Precision arrester screen stops flashback ignition to reduce fire risks.
- Superior chemical resistance.
- Excellent corrosion protection.
- Long length for safe insertion of gas nozzle.
- Faster liquid flow.

Large ID Zone

- Identify contents to reduce misuse or incompatible mixtures.
- Designate department location, work shift, crew or individual user.

Item#	Capacity (Gallons)	Can Dimensions (Outer Dia. x H)
JUS7110100	1	9.5" x 11"
JUS10301	1	7.25" x 11.5"
JUS7120100	2	7.5" x 13.75"
JUS7125100	2.5	11.75" x 11.5"
JUS7150100	5	11.75" x 16.875"

Justrite Type I and Type II Safety Cans are 100% leak tested. 10-Year Warranty. Meet OSHA and NFPA. FM approved, UL/ULC listed, Carb compliant, TÜV certified.

Material Handling - Safety Cans - Type II



Engineered for the highest performance in safety, compliance and convenience.

Patented, innovative manifold automatically vents for smooth, glug-free liquid flow, while the comfortable Safe-Squeeze® trigger offers maximum control when pouring. A 9" flexible metal hose ensures targeted pouring into small openings. Fill port with ergonomically designed handle makes filling easier than ever. All can sizes have extra capacity for mixing in additives for two cycle engines.



AccuFlow™ Innovative Manifold

- Fastest, smoothest, most controlled pouring.
- Quick-open fill port with ergonomic lift lever for easy filling.
- Auto venting protects against pressure build-up.

Stainless Steel Flame Arrester

- Precision arrester screen stops flashback ignition to reduce fire risks.
- Superior chemical resistance.
- Excellent corrosion protection.
- Long length for safe insertion of gas nozzle.
- Faster liquid flow.

Large ID Zone

- Identify contents to reduce misuse or incompatible mixtures.
- Designate department location, work shift, crew or individual user.

Item#	Capacity (Gallons)	Hose Dia. (Inches)	Can Dimensions (Outer Dia. x H)
JUS7210120	1	0.625	9.5" x 10.5"
JUS7220120	2	0.625	9.5" x 13.25"
JUS7225120	2.5	0.625	11.75" x 12"
JUS7225130	2.5	1.0	11.75" x 12"
JUS7250120	5	0.625	11.75" x 17.5"
JUS7250130	5	1.0	11.75" x 17.5"

Abatix' online ordering system is simple to use. Once you are registered and have a customer code, you can create orders, customize shopping lists, and view ordering history, track shipments, view and print invoices and pay bills online. Head over to www.abatix.com and start shopping today.

Material Handling - Storage



Chests



- Recessed and concealed lock protectors for maximum security against drilling and cutting lock. (Model 1332 and 1636 one lock protector only.)
- Finger-groove lid handle for easy opening.
- Convenient storage tray on back wall for small items (Models 2448, 2460, 2472, 3048).
- "X" models do not include rear tray for larger opening.
- Heavy-duty piano hinges with non-removable pin.
- Patented, ergonomically designed fold-down recessed handles.
- Angled 3-1/2" high support skids feature threaded holes for easy caster installation.
- Recommend #1 and #5 Masterlock® padlocks or equivalent.

CAT NO.	UPC NO.	DESCRIPTION
GRE1332	38717	Storage chest without tray
GRE1636	38718	Storage chest without tray
GRE2142	31651	Storage chest without tray
GRE2448	23273	Storage chest
GRE2448X	00852	Storage Chest without tray
GRE2460	23363	Storage chest
GRE2460X	00858	Storage Chest without tray
GRE3048	23362	Storage chest
GRE3048X	00859	Storage Chest without tray
GRE2472	07483	Storage chest
GRE2472X	00853	Storage Chest without tray

SPECIFICATIONS	1332	1636	2142	2448	2460	3048	2472
Capacity FT ³	4.9	6.7	9.7	16.6	20.8	25	25
Weight	78 lbs. (35kg)	101 lbs. (46kg)	124 lbs. (56kg)	159 lbs. (72kg)	184 lbs. (83kg)	200 lbs. (91kg)	214 lbs. (97kg)



Optional casters available for increased mobility.

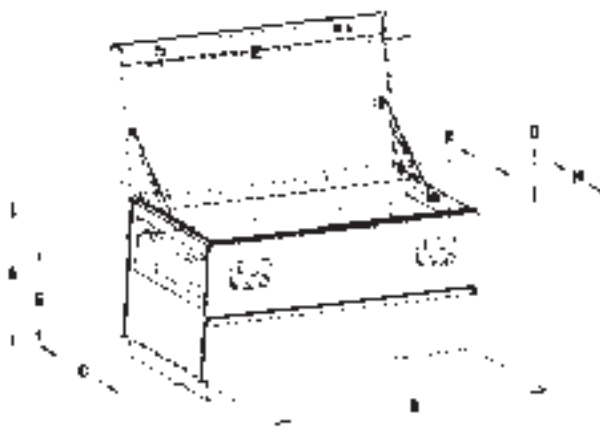

DIMENSIONS									
	A	B	C	D	E	F	G	H	I
GRE1332	14"	32"	19"	—	29.5"	—	—	—	16.75"
GRE1636	17"	36"	19"	—	33.5"	—	—	—	16.75"
GRE2142	20"	42"	20"	—	39.5"	—	—	—	17.75"
GRE2448	25"	48"	24"	4"	45.5"	4"	19"	15.5"	21.75"
GRE2448X	25"	48"	24"	—	45.5"	—	—	15.5"	21.75"
GRE2460	25"	60"	24"	4"	57.5"	4"	19"	15.5"	21.75"
GRE2460X	25"	60"	24"	—	57.5"	—	—	15.5"	21.75"
GRE3048	30"	48"	30"	4"	45.5"	4"	24"	21.5"	27.75"
GRE3048X	30"	48"	30"	—	45.5"	—	—	21.5"	27.75"
GRE2572	25"	72"	24"	4"	69.5"	4"	19"	15.5"	21.75"
GRE2572X	25"	72"	24"	—	69.5"	—	—	15.5"	21.75"



Material Handling - Storage

Slant-Top Boxes



GRE3648



Optional casters available for increased mobility.



- Large capacity storage with traditional slant-top design.
- Recessed, concealed lock protectors provide maximum security against drilling / cutting locks.
- Channel reinforcements on lid, lock side panels into lid for added security when closed.
- Hinged lower shelf enables storage of larger items.
- Angled 3-1/2" high support skids feature threaded holes for easy caster installation.
- Angled handle recess prevents pinch points.
- Features two reinforced steel shelves with large lip to prevent items from rolling off (Model 2260, one shelf only).
- Model 2260 comes with lid support to form waist-high, flat work area.
- Patented, ergonomically designed fold-down recessed handles.
- Recommend #1 and #5 Masterlock® padlocks or equivalent.

CAT NO.	UPC NO.	DESCRIPTION
GRE2260	23270	Slant-top box
GRE3648	23276	Slant-top box
GRE3660	23196	Slant-top box

SPECIFICATIONS	2260	3648	3660
Capacity FT ³	32	34	44
Weight	273 lbs. (124kg)	270 lbs. (123kg)	314 lbs. (142kg)

	DIMENSIONS							
	A	B	C	D	E	F	G	H
GRE2260	32"	22"	32"	36"	12"	12"	21"	—
GRE3648	34"	36"	30"	48"	5"	12"	27"	11"
GRE3660	44"	36"	30"	48"	5"	12"	27"	11"

Flat-Top Boxes



GRE4860



Optional casters available for increased mobility.

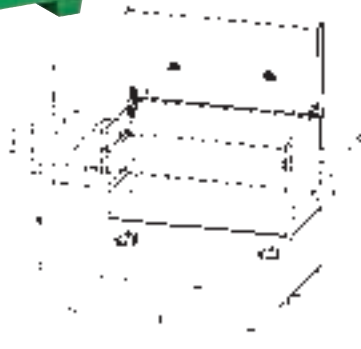

- Flat-top design provides more storage capacity for tall, bulky items, plus a large work surface for jobsite plans.
- Recessed and concealed lock protectors for maximum security against drilling and cutting lock.
- Channel reinforcements on lid, lock side panels into lid for added security when closed.
- Hinged lower shelf allows for easy storage of larger objects (except Model 3360).
- Side-wall storage (except Model 3360).
- Double hinge cover folds up and out of the way.
- Angled 3-1/2" high support skids feature threaded holes for easy caster installation.
- Patented, ergonomically designed fold-down recessed handles.
- Recommend #1 and #5 Masterlock® padlocks or equivalent.

CAT NO.	UPC NO.	DESCRIPTION
GRE3360	38719	Flat-Top box
GRE4848	35043	Flat-Top box
GRE4860	35057	Flat-Top box
GRE4872	07487	Flat-Top box

SPECIFICATIONS	3360	4848	4860	4872
Capacity FT ³	34.5	40	50	60
Weight	256 lbs. (116kg)	283 lbs. (128kg)	358 lbs. (162kg)	373 lbs. (169kg)

	DIMENSIONS									
	A	B	C	D	E	F	G	H	I	J
GRE3360	33"	60"	30"	—	12.5"	12"	20"	—	—	—
GRE4848	48"	48"	30"	11"	7"	12"	27"	2"	3"	17"
GRE4860	48"	60"	30"	11"	7"	12"	27"	2"	3"	17"
GRE4872	48"	72"	30"	11"	7"	12"	27"	2"	3"	17"

EXPERIENCE THE DIFFERENCE

Material Handling - Storage



Field Office

- Slanted work surface with lockable, concealed storage area.
- Concealed lock protectors protect locks from drilling and cutting.
- Weather stripping on doors to help protect documents and tools from the elements.
- Lid with heavy-duty gas spring and a locking arm for ease of opening and safety.
- Shelving throughout, for organizing and storing jobsite tools and supplies.
- Grooved front doors for ease of opening and storage compartment access.
- Patented, ergonomically designed fold-down recessed handles.
- Continuous, non-removable pin hinges.
- Overlapping corners, rolled edges, and strategically placed reinforcements for added strength.
- Recommend #1 and #5 Masterlock padlocks or equivalent.
- Welded 16-gauge steel construction for durability.
- Transportable with forklift.
- Optional casters available for increased mobility.



GRE8060-DLX

CAT NO.	UPC NO.	DESCRIPTION
GRE8060-DLX	04719	Field Office

SPECIFICATIONS

Capacity FT ³	60.4
Weight	549 lbs. (249kg)



Tamper-proof lock protectors (for upper and lower doors).



Slanted work surface with lockable, concealed storage area.



Door grooves provide a gripping surface for convenient opening.



Top door opens with a gas spring and is supported by a locking arm.

(Tools sold separately)



Optional casters available for increased mobility.

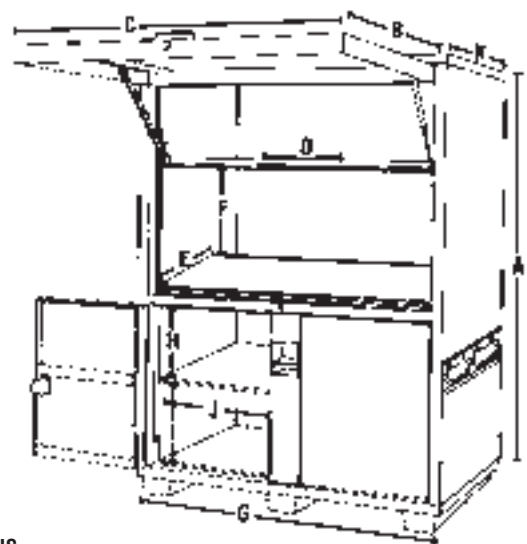

DIMENSIONS

A	B	C	D	E	F	G	H	I	J	K
80"	41.6"	55.6"	20.6"	26.8"	19.2"	60"	14"	15.5"	24"	42"



Plumbing & Mechanical - Pipe Wrenches

Heavy-Duty Pipe Wrenches

RIDGID Pipe Wrenches are world-renowned for their unsurpassed toughness and serviceability. The original heavy-duty pipe wrench has earned the confidence of pipe professionals for over 80 years because it does the job right the first time, every time. RIDGID Pipe Wrenches are also available in a wide variety of purpose-built configurations, and are available with cast aluminum handles that offer an average 40% weight reduction.



Straight Pipe Wrench

- Sturdy, cast-iron housing and I-beam handle with full floating forged hook jaw, featuring self-cleaning threads with replaceable hook and heel jaws.
- Heavy-duty pipe wrenches comply with federal specifications GGG-W651E, Type II, Class A.

Catalog No.	Model No.	Nom. Size		Pipe Capacity		Weight		Std. Pack
		in.	mm	in.	mm	lb.	kg	
31010	10	10	250	1-1/2	40	1-3/4	0.8	6
31020	14	14	350	2	50	3-1/2	1.6	6
31025	18	18	450	2-1/2	65	5-3/4	2.6	6
31030	24	24	600	3	80	9-3/4	4.4	6
31045	60	60	1500	8	200	51-1/4	23.3	1

Aluminum Pipe Wrenches

- Nearly 40% lighter than comparable cast-iron wrenches.
- Jaws and all other parts identical to RIDGID heavy-duty wrenches.

Aluminum Straight Pipe Wrench

- Professional strength in lightweight aluminum.
- Offers the same durability and ease-of-use found in all RIDGID heavy-duty wrenches.



Catalog No.	Model No.	Nom. Size		Pipe Capacity		Weight		Std. Pack
		in.	mm	in.	mm	lb.	kg	
31090	810	10	250	1-1/2	40	1	0.4	6
31095	814	14	350	2	50	2-1/2	1.1	6
31100	818	18	450	2-1/2	65	3-3/4	1.7	6
31105	824	24	600	3	80	6	2.7	6
31110	836	36	900	5	125	11	5.0	1

Strap Wrenches

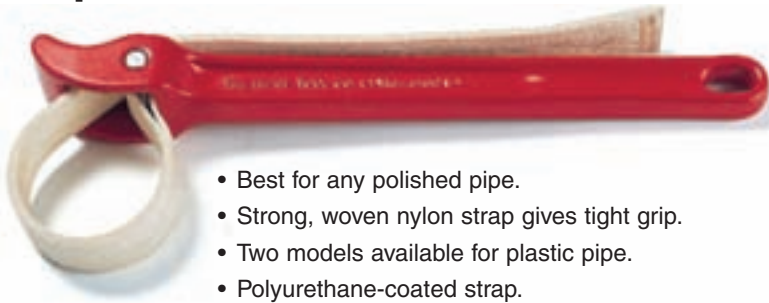

- Best for any polished pipe.
- Strong, woven nylon strap gives tight grip.
- Two models available for plastic pipe.
- Polyurethane-coated strap.

Replacement Straps

Catalog No.	Strap Length		Strap Width	
	in.	mm	in.	mm
32015	17	425	1-1/8	30
32050	29-1/4	750	1-3/4	45
32055	48	1200	1-3/4	45

Catalog No.	Model No.	Handle Length		Strap Length		Strap Width		Pipe Capacity		Tube Capacity (O.D.)		Weight		Std. Pack
		in.	mm	in.	mm	in.	mm	in.	mm	in.	mm	lb.	kg	
31340	2	11-3/4	300	17	425	1-1/8	30	2	50	3-1/2	90	1-3/4	0.8	1
31360	5	18	450	29-1/4	750	1-3/4	45	5	125	7	175	2	0.9	1
31365	5	18	450	48	1200	1-3/4	45	5	125	12	300	2	0.9	1

Plumbing & Mechanical

Plumbing & Mechanical - Pipe & Tubing Cutters



Pipe Cutters

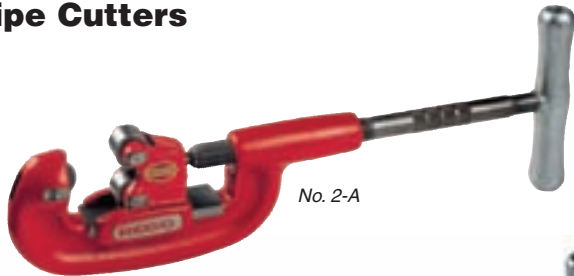

No. 2-A



No. 6-S



No. 42-A

Heavy-Duty Pipe Cutters

- Fast, clean pipe cutting by hand or power.
- Extra-long shank protects adjustment threads, while an extra-large handle is provided for quick, easy adjustment.
- Can be converted to 3-wheel cutter by replacing rollers with cutter wheel, or the 2A can be ordered as 3-wheel model for use in areas where a complete turn is not possible.

Catalog No.	Model No.	Pipe Cutter Description	Nominal Size		Pipe Capacity Weight	
			in.	mm	lb.	kg
32820	2-A	Heavy-Duty	1/8-2	3-50	7	3.2
32850	6-S	Heavy-Duty	4-6	100-150	22	10.0

4-Wheel Pipe Cutter

- Designed for work in areas where a complete turn is impossible.
- Short handle for use in areas where only a 130° turn can be made.
- Equipped with four heavy-duty wheels.

Catalog No.	Model No.	Pipe Cutter Description	Pipe Capacity Nominal Size		Weight	
			in.	mm	lb.	kg
32870	42-A	Heavy-Duty 4-Wheel	3/4-2	20-50	6-3/4	3.1

Tubing Cutters



No. 15



No. 151

Close Quarter Tubing Cutters

- Specifically designed for use in restricted spaces on small diameter, hard and soft copper, aluminum, brass and plastic tubing; rollers include grooves for close-to-flare cuts.
- Strong, lightweight slide and wheel housing, large knurled feed screw knob gives easy control of cutting pressure for clean cuts.

Catalog No.	Model No.	Description	Std. Wheel	Capacity		Weight		Std. Pack
				in.	mm	lb.	kg	
32975	103	Close Quarters Cutter	E-3469	1/8 - 5/8	3-16	1/3	0.15	6
32985	104	Close Quarters Cutter	E-3469	3/16 - 15/16	5-24	1/3	0.15	6

Tubing and Conduit Cutters with X-CEL Feature

- Clean, square cuts are easily made on copper, brass, aluminum and thin-wall conduit.
- Includes X-CEL Knob for quicker cutting.
- Convenient fold-away reamer.



Catalog No.	Model No.	Description	Std. Wheel	Capacity		Weight		Std. Pack
				in.	mm	lb.	kg	
32920	15	Screw Feed Cutter	F-158	3/16 - 1-1/8	5-28	1-1/2	0.68	6

Quick-Acting Tubing Cutters with X-CEL Feature

- Quick-acting design, I-beam construction, hardened wear surfaces and thrust bearing slide assemblies for smooth operation.
- E-CEL Knob and X-CEL Pin for quicker cutting and wheel replacement.
- Fold-away reamers.

Catalog No.	Model No.	Description	Std. Wheel	Capacity		Weight		Std. Pack
				in.	mm	lb.	kg	
31632	151	Quick-Acting Cutter	E-3469	1/4 - 1-5/8	6-42	1-1/4	0.56	6
31642	152	Quick-Acting Cutter	E-3469	1/4 - 2-5/8	6-66	2	0.92	1

Plumbing & Mechanical - Threading



Manual Ratchet Threaders

All matched Threader/Sets include Die Heads, Ratchet Assembly, Ratchet Handle and Alloy Dies. All Threader Sets use same 12-R Dies in Die Head.

Exposed Ratchet Threader Set

Catalog No.			Model No.	Capacity		Weight	
NPT	BSPT	NPSM		in.	mm	lb.	kg
36475	65255	36510	12-R	1/2 - 2	12-50	34-3/4	15.8

Die Heads – Manual Threaders – 00-R, 12-R, 11-R and 00-RB (North American Standards)

	Catalog No.									
	Nominal Pipe Size (in.)									
	1/8	1/4	3/8	1/2	3/4	1	1-1/4	1-1/2	2	
Model No. 00-R										
(NPT)										
Alloy RH	36875	36880	36885	36890	36895	36900	–	–	–	
High-Speed RH	36935	36940	36945	36950	36955	36960	–	–	–	
High-Speed for Stainless Steel RH	36965	36970	36975	36980	36985	36990	–	–	–	
(NPSM)										
Alloy RH	36995	37000	37005	37010	37015	37020	–	–	–	
API High-Speed	–	–	834435	68755	68750	–	–	–	–	
Model No. 12-R										
(NPT)										
Alloy RH	37375	37380	37385	37390	37395	37400	37405	37410	37415	
High-Speed LH	–	–	–	37435	37440	37445	37450	37455	37460	
High-Speed RH	37465	37470	37475	37480	37485	37490	37495	37500	37505	
High-Speed for Stainless Steel RH	37510	37515	37520	37525	37530	37535	37540	37545	37550	
High-Speed for PVC RH	–	83450	83455	83460	83465	83470	83475	83480	83485	
High-Speed for Plastic Coated Pipe	–	–	–	51857	51862	51867	51872	51877	51882	
Alloy for IMC RH	–	–	–	92690	92695	92700	92705	92710	92715	
(NPSM)										
Alloy RH	37555	37560	37565	37570	37575	37580	37585	37590	37595	
Model No. 11-R										
(NPT)										
Alloy RH	37025	37030	37035	37040	37045	37050	37055	20923	20943	
High-Speed RH	37095	37100	37105	37110	37115	37120	37125	20928	29048	
High-Speed for Stainless Steel RH	37130	37135	37140	37145	37150	37155	37160	20933	20953	
(NPSM)										
Alloy RH	37165	37170	37175	37180	37185	37190	37195	20938	20958	
Model No. 00-RB	1/4 20 TPI	5/16 18 TPI	3/8 16 TPI	7/16 14 TPI	1/2 13 TPI	9/16 12 TPI	5/8 11 TPI	3/4 10 TPI	7/8 9 TPI	1 8 TPI
(UNC)										
Alloy RH	37610	37615	37620	37625	37630	37635	37640	37645	37650	37655
Alloy LH	–	–	–	37675	–	–	–	37695	–	–
(UNF)	28 TPI	24 TPI	24 TPI	20 TPI	20 TPI	18 TPI	18 TPI	16 TPI	14 TPI	14 TPI
Alloy RH	37710	37715	37720	37725	37730	37735	37740	37745	–	37755
Alloy LH	–	–	–	37775	37780	37785	37790	37795	37800	37805

Unless highlighted, all Die Heads complete come with selected dies and are set at the factory.

Highlighted Die Heads require assembly with supplied dies.

All matched Threader/Sets include Die Heads, Ratchet Assembly, Ratchet Handle and specified Dies.

EXPERIENCE THE DIFFERENCE

Plumbing & Mechanical - Threading

Hand-Held Power Drive

Model 700 Power Drive

- Heavy-duty hand-held power drive.
- Features reversible 115V Universal motor.
- Capacity 1/8"-2" (3mm-50mm) pipe, 1/4"-1" bolt with OO-RB die heads. Designed for RIDGID No. 12-R die heads. Other RIDGID die heads (OO-R, OO-RB, 11-R) using adapters, threading 2 1/2" through 6" (62mm-150mm) with 141/161 geared threaders.
- Approved by CSA to CSA and UL standards.

Technical Specifications

Motor: Universal, 1/2 HP, 115V 25-60 Hz.

Switch: Double-throw reversible.

Gear Head: All-spur gear reduction. Spring-loaded adapter pawl. Hardened steel spindle gear.

Body: Cast aluminum.

Spindle Speed: 26-30 RPM (no load).

Capacity: 1/8"-2" Pipe (30mm-50mm)
1/4"-1" Bolt (using OO-RB)

Weight: 25 lbs. (11kg) Power Drive only.

Length: 28 1/4" (71.7cm).



Catalog No.	Model No.	Description	Pipe Threading Capacity		Rod Threading Capacity		Maximum Geared Threader Capacity		Weight	
			in.	mm	in.	mm	in.	mm	lb.	kg
41935	700	115V 25-60 Hz Only	1/8-2	3-50	1/4-1	6-25	6	150	31	14



Support Arm



Optional Carrying Case



Use the 775 Support Arm to help resist torques developed when threading 1" in diameter and larger.

Catalog No.	Model No.	Accessories Description	Weight	
			lb.	kg
42600	770	Adapter for OO-R and OO-RB	3-3/8	2
42605	771	Adapter for O-R	3-3/8	2
42610	772	Adapter for 11-R	3 1/2	2
42615	773	Adapter for 111-R	3	1
42620	774	Square Drive Adapter - 15/16"	5 1/4	2
42625	775	Support Arm for No. 700	11	5
42950	B-171-X	Metal Carrying Case for No. 700 and Accessories	29	13
10883	418	Oiler w/1 Gal. Nu-Clear Thread Cutting Oil	20 1/2	9.4
41620	-	Gearhead Motor Grease	1	0.5

Plumbing & Mechanical - Threading
Power Drives and Threading Machines

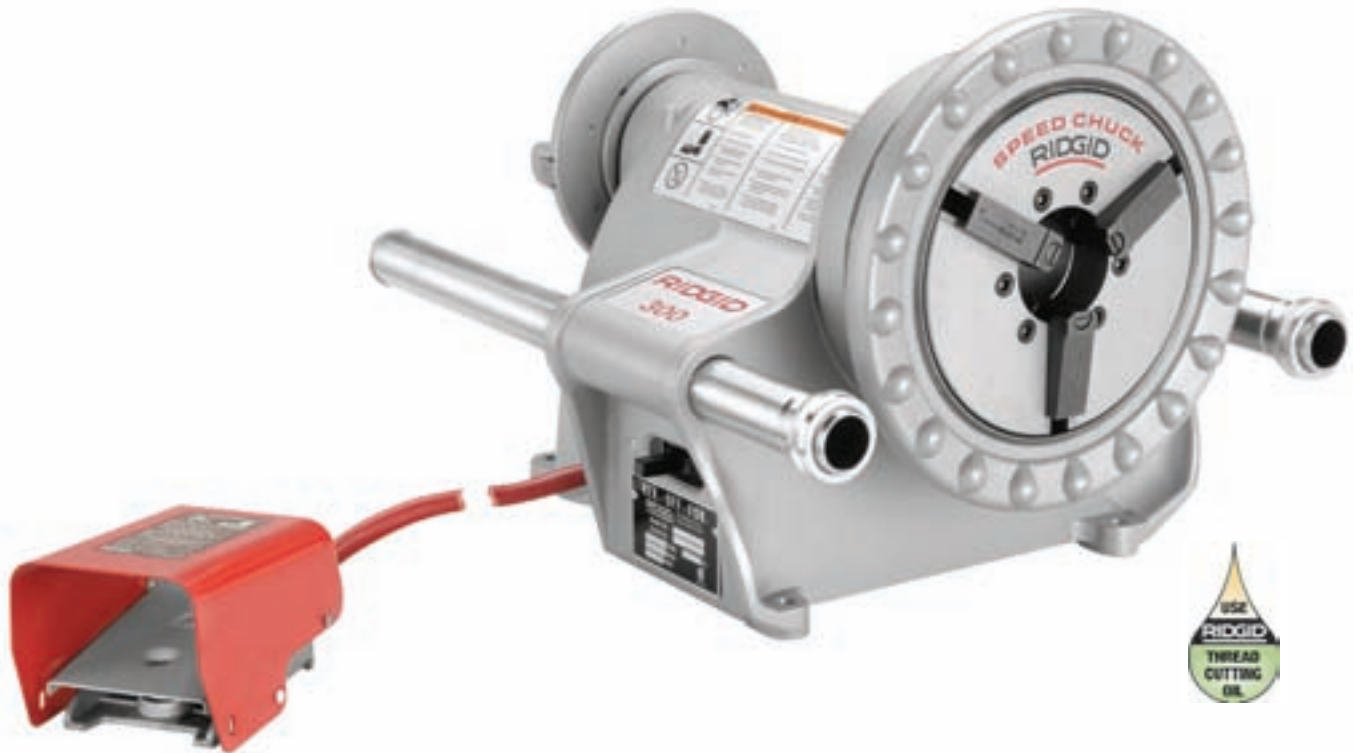

Plumbing & Mechanical

Model 300 Power Drive Only

- RIDGID speed chuck.
- Reversible 1/2 HP universal motor.
- Capacity: 1/8" - 2" (3mm - 50mm) pipe, 2-1/4" - 4" with 141 and 4" - 6" with 161 Geared Threaders; 1/4" - 2" (6mm - 50mm) rod.
- Recessed On/Off/Reverse switch.
- 115V, 38 RPM approved by CSA to CSA and UL standards.

Technical Specifications

- Motor: 1/2 HP, universal, reversible motor, single-phase, 25-60 Hz, 115V (230V available).
- Switch: Heavy-duty FOR/OFF/REV and Integral Foot Switch.
- Chuck: RIDGID speed chuck with replaceable rocker-action jaws.
- Spindle Speed: 38 RPM (57 RPM available).
- Rear Centering Device: Cam-action turns with chuck.
- Support Bar: Heavy-duty (2).

Catalog No.	Model No.	Description	Spindle Speed RPM	Pipe Threading Capacity		Rod Threading Capacity		Max. Geared Threader Capacity		Weight	
				in.	mm	in.	mm	in.	mm	lb.	kg
15682	300 Complete	115V, 25-60 Hz (NPT)	38	1/8 - 2	3-50	1/4 - 2	6-50	6	150	212	96.2
15722	300 Complete	115V, 25-60 Hz (NPT)	57	1/8 - 2	3-50	1/4 - 1-1/2	6-40	6	150	212	96.2
41855	300 Only	115V, 25-60 Hz	38	1/8 - 2	3-50	1/4 - 2	6-50	6	150	94	43.0
75075	300 Only	115V, 25-60 Hz	57	1/8 - 2	3-50	1/4 - 1-1/2	6-40	6	150	94	43.0
41860	300 Only	230V, 25-60 Hz	38	1/8 - 2	3-50	1/4 - 1-1/2	6-40	6	150	94	43.0
75435	300 Only	230V, 25-60 Hz Export	38	1/8 - 2	3-50	1/4 - 2	6-50	6	150	94	43.0
97415	300A Complete	230V, (NPT) Export	38	1/8 - 2	3-50	1/4 - 2	6-50	6	150	202	91.6
97420	300A Complete	230V, (BSPT) Export	38	1/8 - 2	3-50	1/4 - 2	6-50	6	150	202	91.6

Plumbing & Mechanical - Threading

Power Threading Machine



Model 300 Complete

Convert your 300 Power Drive into a portable threading machine. Includes these accessories for enhanced field performance.

- 1 – Die heads and dies for use with 300 Power Drive with 311 carriage.
 - 2 – No. 360 Cutter: Capacity: 1/8"-2" (3mm-50mm) pipe, 1/4"-7/8" (6mm-22mm) rod with F-3 wheel, 5/16"-1" (8mm-25mm) with E-1032 cutter wheel.
 - 3 – No. 341 Reamer: Positive-locking, 5-flute cone, right-hand 1/8"-2" (3mm-50mm). Special E863 RH/LH combination reamer cone available.
 - 4 – No. 311 Carriage with lever.
 - 5 – No. 1206 Stand or Transporter.
- No. 1452 Clip-On Tool Tray.
 - No. 418 Oiler with 1 gallon of Nu-Clear thread cutting oil.
 - No. 819 Nipple Chuck.
 - No. 32 Transporter.

Add a No. 304 retrofit kit to convert the 300 Power Drive to automatic oiling:

- Gear head assembly with oil pump.
- Oil pan assembly.
- Oil spout.
- Support bar.
- Necessary connectors.
- One gallon of Nu-Clear thread cutting oil.

See previous page for Model 300 Complete selection.

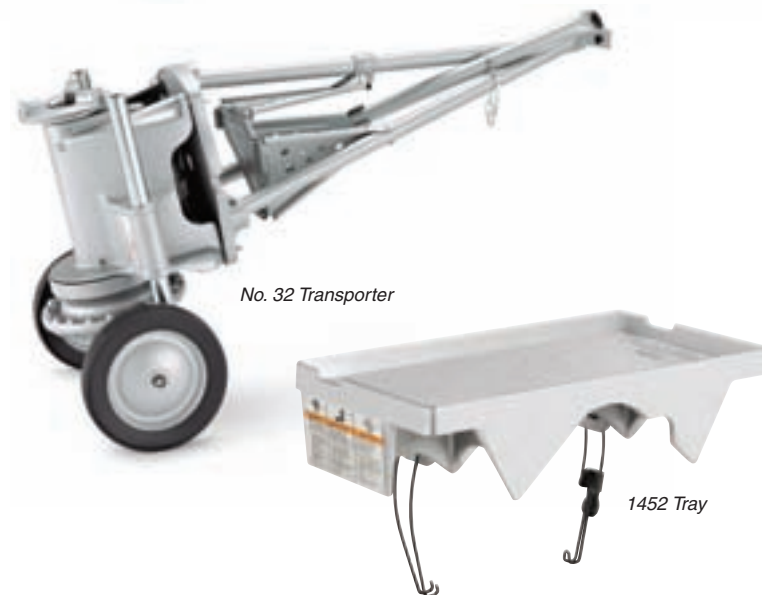

No. 32 Transporter

1452 Tray

Catalog No.	Model No.	Accessories Description	Weight	
			lb.	kg
42360	1206	Stand for 300 Power Drive	31	14.1
83540	1206	Stand for 300 Power Drive Export	31	14.1
42575	32	Transporter (for Power Drives and Tri-stand Vises)	14¼	6.5
68815	311	Carriage with No. 312 Lever	15	6.8
42385	312	Carriage Feed Lever	3	1.4
10883	418	Oiler with 1 gallon of Nu-Clear Thread Cutting Oil	20½	9.4
42365	341	Reamer for No. 311 Carriage with Lever	7	3.2
42370	360	Cutter for No. 311 Carriage	8½	3.9
97065	811A	Universal Q.O. Die Head Only, Right-Hand Only	12½	5.7
97075	815A	Self-Opening Die Head Only, Right-Hand Only	13½	6.1
51005	819	Nipple Chuck Complete, ½"-2" (12mm-50mm)	10½	4.8
42380	1452	Clip-On Tool Tray	6	2.7
97345	304	Retrofit Kit (38 rpm)	37¾	17.1
97350	304	Retrofit Kit (57 rpm)	37¾	17.1
97365	-	Jaw Inserts for Coated Pipe	½	0.2
46660	E-863	LH/RH Reamer Cone	7	3.2
41620	-	Gearhead Motor Grease	1	0.5



Plumbing & Mechanical - Threading

Model 1224 Threading Machine

Capacities

- **Pipe:** 1/4"-4" (6mm-100mm) 4"-6" (100mm-150mm) with 161 geared threader.
- **Bolt:** 1/4"-2" (6mm-50mm)

Features

- Threads 1/4" - 2" pipe at 36 RPM and 2-1/2" - 4" at 12 RPM.
- The 1224 threads a wide range of pipe including black, galvanized and plastic-coated pipe, together with stainless steel, IMC and heavy-wall conduit, as well as rod up to 30 Rockwell C.
- An induction motor insures sound levels well within the limits set by the regulating authorities.
- A special capacitor-start / capacitor-run motor allows the 1224 to thread a full range of material where voltage drop is experienced.
- 1/4" - 2" Universal Die Head; 2-1/2" - 4" receding die head allows cutting of tapered or straight NPT/NPSM or BSPT/BSPP threads.
- Constant and proper lubrication of dies and workpiece with through-head oiling.
- 115V approved by CSA to CSA and UL standards.

Technical Specifications

- Motor: 1-1/2 HP, single-phase, 60 Hz or 50 Hz, induction type.
- Motor Control: Reverse/Off/Forward, heavy-duty rotary-type and integral foot switch.
- Spindle Speed: 36/12 RPM.
- Gear Box: Two-speed gear box 3:1 ratio.
- Chuck: Hammer-type with replaceable rocker-action jaw inserts.
- Rear Centering Device: Cam action.
- Cutter: Model 764 full-floating, self-centering 1/4"-4" with F-229 cutter wheel.
- Reamer: Model 744, 1/4"-4" blade-type.
- Oiling: Through die head.
- Pump: Self-priming, gerotor-type, automatic-reversing, constant-flow.



Standard Equipment

Model No. 1224 threading machine with foot switch:

- One - No. 714 (914) 2-1/2" - 4" receding self-opening die head.
- One - No. 711 (911) 1/4" - 2" universal self-opening die head.
- One set 1/2" - 3/4" universal alloy dies.
- One set 1" - 2" universal alloy dies.
- One set 2-1/2" - 4" 1224 high-speed dies.
- One gallon Nu-Clear oil. Catalog numbers 25112, 26107 and 31442 do not include oil. Oil must be ordered separately.
- Three hex keys.
- One spare F-229 cutter wheel.
- One 3/4" combination wrench.
- One tool box.
- One No. 744 reamer.
- One No. 764 cutter.

Catalog No.	Model No.	Description	Weight	
			lb.	kg
26092	1224	1/2-4 NPT 120V 60 Hz	509	231.0
26097	1224	1/2-4 NPT 240V 60 Hz	509	231.0
26127	1224	1/2-4 BSPT 120V 60 Hz	509	231.0
26112	1224	1/2-4 BSPT 115V 50 Hz	509	231.0
26122	1224	1/2-4 BSPT 240V 60 Hz	509	231.0
26107	1224	1/2-4 BSPT 220V 50 Hz	509	231.0
26102	1224	1/2-4 BSPT GS 220V 50 Hz	526	238.5
31442	1224	1/2-4 NPT 250V 50 Hz	509	231.0

Stands

Catalog No.	Model No.	Description	Weight	
			lb.	kg
92457	100A	Universal Leg & Tray Stand	75	34.5
92462	150A	Universal Wheel & Tray Stand	103	46.7
92467	200A	Universal Wheel & Cabinet Stand	164	74.5
22563	-	Steel Cabinet	42	19.3

Pipe Dies 2 1/2" - 4"

Catalog No.	Description	Capacity		Weight	
		In.	mm	lb.	kg
26192	1224 H.S. Dies NPT	2 1/2-4	62-100	2 1/4	1.0

EXPERIENCE THE DIFFERENCE

Plumbing & Mechanical - Threading



Model 535A Automatic Threading Machine

Capacities

- **Pipe:** 1/8"-2" (3mm-50mm) 2½"-4" (62mm-100mm) with 141 geared threader.
- **Bolt:** 5/16"-2" (8mm-50mm)

The Model 535A maintains the ruggedness of the industry workhorse while adding the features that make the threading operation more productive. A large chip tray and oil reservoir make the 535A ideal for longer uninterrupted threading. The 535A features a high clearance carriage that makes the threading operation easier and a generous top cover area that is ideal for keeping tools and work related materials handy. The 535A is designed around maximum uptime with the upgrades that matter most to the pipe working professional. Users also benefit from the part commonality between the 535, the 535A Automatic and other RIDGID equipment.

Features

- Automatic chuck.
- 3-Speed (16/46/58 RPM) transmission
- Large 1.75 gallon oil reservoir.
- 100% Greater chip tray capacity.
- Generous top cover area for keeping tools and fittings handy.
- High clearance carriage.
- Can be used with geared threader Model 141.
- Uses Model 816/817 semi-automatic, Model 815A self-opening or Model 811A quick-opening die heads.
- Length gauge for quick, accurate cut-off.
- CSA approved.
- Approved by CSA to CSA and UL standards.

Technical Specifications

- Motor: 2 HP, single-phase, 115V, 60 Hz, 20 Amp reversible induction motor.
- Switches: FOR/OFF/REV and Integral safety foot switch.
- Chuck: automatic with four reversible forged jaws.
- Rear Centering Device: automatic, centering only.
- Cutters: Self-centering, full-floating.
Two models available:
 - One Standard. No. 820 Wheel-Type Cutter, pipe capacity 1/8"-2" (3mm-50mm), bolt capacity ¼"-1" (6mm-25mm).
 - Two Optional. No. 821 Blade-Type cutter, pipe capacity ½"-2" (12mm-50mm).
- Spindle Speed: 3 speed 16/46/58 RPM.
- Reamer: 5-flute cone, RH, 1/8"-2" (3mm-50mm).
- Oil Pump: Self-priming gerotor oil pump.
- RH/LH combination reamer available.



Standard Equipment

- Model No. 535A automatic threading machine with foot switch:
- One - No. 811A universal quick-opening die head.
 - One - No. 341 reamer.
 - One - No. 820 cutter.
 - One set ½" - ¾" universal high-speed dies.
 - One set 1" - 2" universal high-speed dies.
 - One gallon stainless steel premium oil.
 - Two hex wrenches. Replacement hex wrenches: 5/32" - No. 46015, 3/16" - No. 46030.
 - One spare E-1032 cutter wheel.

Model 535A Standard Machines

Catalog No.	Model No.	Description 115V 25-60 Hz	Cutter Model	RPM	Chuck	Die Head	Volt	Weight	
								lb.	kg
91142	535A	Automatic Machine only	820	16/46/58	Automatic	-	115V	340	155
84097	535A	1/2" - 2" NPT Automatic	820	16/46/58	Automatic	811A	115V	350	159
91322	535A	1/2" - 2" NPT Automatic	820	16/46/58	Automatic	816/817	115V	360	163

Machines listed as 1/2" - 2" include standard equipment. Machine only includes standard equipment less all die heads and dies.

Plumbing & Mechanical - Threading



Model 535A Machine Stands and Accessories



No. 100A



No. 150A



No. 200A with Steel Cabinet

Steel Cabinet Features

- 17 Gauge steel walls and welded construction.
- Two internal and one external storage shelves.
- Oversized bi-fold door with steel clasp.
- Cut-outs for power cord and foot switch storage.
- Two drain plugs for easy cleaning.

Model 535A Machine Accessories

Catalog No.	Model No.	Description	Weight	
			lb.	kg
42365	341	Reamer	6-3/4	3.1
42390	820	Wheel-Type Cutter	8-1/2	3.9
92457	100A	Universal Leg and Tray Stand	75	34.5
92462	150A	Universal Wheel and Tray Stand	103	46.7
92467	200A	Universal Wheel and Cabinet Stand	104	74.5
51005	819	Nipple Chuck Complete 1/2"-2"	10-1/2	4.8
41620	-	Gearhead Motor Grease	1	0.5
35867	839	Adapter Kit for 819 Nipple Chuck	16-1/2	7.5
97882	535A	141 Mounting Kit	12	5.4
12138	535A	Left Hand Threading Kit	2-1/2	1.2
42485	4U	Die Head Rack	8-1/2	3.9
42490	6U	Die Head Rack	12-1/2	5.7
97065	811A	NPT Die Head Quick-Open R.H.	12-1/2	5.7
97075	815A	NPT Die Head Self-Open R.H.	13	5.9
23282	842	NPT Die Head Quick-Open L.H.	12-1/2	6.7
97070	811A	BSPT Die Head Quick-Open R.H.	12-1/2	6.7
97080	815A	BSPT Die Head Self-Open R.H.	13	6.9
97045	531	Bolt Die Head Quick-Open R.H./L.H. 1/4" - 1"	7-1/2	3.4
97050	532	Bolt Die Head Quick-Open R.H./L.H. 1-1/8" - 2"	9	4.1
84537	816	1/8"-3/4" Semi-Automatic Die Head	13	5.9
84532	817	1"-2" Semi-Automatic Die Head	13	5.9

Note: Mono Die Heads available, 1/8", 1/4", 3/8", 1/2", 3/4", 1", 1-1/4", 1-1/2", 2". All Die Heads are through-head oiling.

Plumbing & Mechanical



Use High Speed Dies when threading at 45 RPM or greater.

Plumbing & Mechanical - Threading



Die Heads – Ratchet Threaders – 00-R, 12-R, 11-R (British and International Standards)

	Catalog No.								
	Nominal Pipe Size (in.)								
	1/8	1/4	3/8	1/2	3/4	1	1-1/4	1-1/2	2
Model No. 00-R									
(BSPT)									
Alloy RH	65705	65710	65715	65720	65725	65730	-	-	-
High-Speed RH	65765	65770	65775	65780	65785	65790	-	-	-
Model No. 12-R									
(BSPT)									
Alloy RH	65950	65955	65960	65965	65970	65975	65980	65985	65990
High-Speed LH	-	-	-	-	-	66020	-	66030	66035
High-Speed RH	-	-	-	66040	66045	66050	66055	66060	66065
High-Speed for JIS RH	-	-	-	92585	92590	92595	92600	92605	92610
(BSPP)									
Alloy RH	-	49932	49937	49942	49947	49952	-	49962	49967
Model No. 11-R									
(BSPT)									
Alloy RH	65550	65555	65560	65565	65570	65575	65580	-	-
High-Speed RH	-	-	65620	65625	65630	65635	65640	-	-
(BSPP)									
Alloy RH	-	-	65680	65685	65690	65695	65700	-	-

British and International Standards

	Catalog No.				
	Nominal Pipe Size (in.)				
	16mm	20mm	25mm	32mm	40mm
Model No. 11-R					
(ISO)					
Alloy RH	37025	37030	37035	37040	37045

All Die Heads complete come with selected dies and are set at the factory.
 Highlighted Die Heads require assembly with supplied dies.
 All matched Threader/Sets include Die Heads, Ratchet Assembly, Ratchet Handle and specified Dies.



Thread Cutting Oil

RIDGID thread cutting oils are free of chlorine and other halogens, PCBs and heavy metals.

Endura-Clear™ is specially formulated to maximize wear resistance which increases die life up to 60% and significantly cuts operating costs up to 30% over Nu-Clear. The formulation has been tested to assure chemical compatibility with FlowGuard Gold®, BlazeMaster®, and Corzan® pipe and fittings and has been added to the FBC™ System Compatible Program.

Dark Oil – Traditional mineral oil with low odor and anti-mist formulation.

Nu-Clear® Oil – Clear mineral oil with low odor and anti-mist formulation. Special low temperature properties maintain workable viscosity to -20°F.

Extreme Performance Oil – High performance mineral oil formulated to produce superior quality threads on stainless steel and black pipe.

- Cools threads and pipe during operation.
- Speeds metal removal.
- Improves thread quality.
- Reduces threading torque.



Container Size		Catalog No.				Containers Per Case	Weight per Case	
U.S.	Metric	Nu-Clear	Dark	Endura-Clear	Extreme Performance		lb.	kg
1 Qt.*	0.94 L		41590	-		12	22	10.0
1 Gal.	3.78 L	70835	70830	32808	74012	6	50	22.7
5 Gals.	18.90 L	41575	41600	-	74047	1	42	19.1
55-Gal. Drum	207.90 L	41610	41610	-	76767	1	465	211.0
16 oz.**	0.38 L	-	-	-	22088	12	12	5.4

*Flip-top included with every quart bottle. **Aerosol can.



Plumbing & Mechanical - Pipe Vises & Supports

Pipe Vise



Portable TRISTAND® Vise

- Integral legs and tray fold in for easy carrying and setup. Large vise base overhangs front legs for clear tool swing.
- Complete with slots for hanging tools, pipe rest, three-pipe benders and ceiling brace screw.
- Larger work surface for increased pipe capacity, 6" diameter, rear support and receding ceiling brace screw.

Cat. No.	Model No.	Description	Pipe Capacity		Weight		Std. Pack
			in.	mm	lb.	kg	
36273	460-6	Portable TRISTAND Chain Vise	1/8 - 6	3-150	47	21.0	1

Pipe Stands



V Head Pipe Stands

Cat. No.	Model No.	Description	Height Adjustment Low-High		Max. Pipe Capacity		Max. Weight Capacity		Weight	
			in.	cm	in.	mm	lb.	kg	lb.	kg
56657	VJ-98	V Head Low Pipe Stand	20-38	51-96	12	300	2500	1136	21	9.5
56662	VJ-99	V Head High Pipe Stand	28-52	71-132	12	300	2500	1136	23	10.4

Adjustable Pipe Support

Cat. No.	Model No.	Description	Height Adjustment Low-High		Max. Pipe Capacity		Max. Weight Capacity		Weight	
			in.	cm	in.	mm	lb.	kg	lb.	kg
42505	46	Adjustable Pipe Support	23-33	59-84	6	152	1134	514	23	10.4



EXPERIENCE THE DIFFERENCE

Poly Sheeting

POLYETHYLENE FILM PRODUCTS

Multi-Purpose Economy Rolls

Multi-Purpose Polyethylene Film is folded, wound on laminated cores and packaged neatly in labeled cartons that are convenient for storage or handling.

Item#	Size	Thickness	Color	Weight
PLY212C	12' x 200'	2 Mil	Clear	22.9 lbs./roll
PLY220C	20' x 200'	2 Mil	Clear	38.2 lbs./roll
PLY408C	8' x 100'	4 Mil	Clear	15.3 lbs./roll
PLY410C	10' x 100'	4 Mil	Clear	19.1 lbs./roll
PLY412C	12' x 100'	4 Mil	Clear	22.9 lbs./roll
PLY420B	20' x 100'	4 Mil	Black	38.2 lbs./roll
PLY420C	20' x 100'	4 Mil	Clear	38.2 lbs./roll
PLY610C	10' x 100'	6 Mil	Clear	28.7 lbs./roll
PLY612C	12' x 100'	6 Mil	Clear	34.4 lbs./roll
PLY620B	20' x 100'	6 Mil	Black	57.4 lbs./roll
PLY620C	20' x 100'	6 Mil	Clear	57.4 lbs./roll
PLY1020C	20' x 100'	10 Mil	Clear	95.5 lbs./roll

Paint and Accoustic Films

Both lightweight and economical, these products assure ease of handling in quick-moving masking operations.

Item#	Size	Thickness	Color	Weight
PLY1512C	12' x 200'	1.5 Mil	Clear	17.2 lbs./roll
PLY1520C	20' x 200'	1.5 Mil	Clear	28.8 lbs./roll

Flame Retardant Film

This film is milky translucent white in color due to the content of stabilizing flame retardant additives designed specifically for low density polyethylene films. It is an antimony-trioxide-halogen based system, which imparts flame retardant properties by:

- Interfacing with the combustion process
- Reducing the transfer of heat from the flame to the film
- Resulting in a film that is much less flammable.

Flame Retardant Film has been tested in accordance with Section 13121 of the Health and Safety Code, State of California. It was found to meet the requirements of the State Fire Marshal for interior flame retardant materials, and has been registered accordingly, #F-325. Those tests were conducted in accordance with ASTM D568-68.

Item#	Size	Thickness	Weight
PLY410FR	10' x 100'	4 Mil	19.1 lbs./roll
PLY412FR	12' x 100'	4 Mil	22.9 lbs./roll
PLY420FR	20' x 100'	4 Mil	38.2 lbs./roll
PLY610FR	10' x 100'	6 Mil	28.7 lbs./roll
PLY612FR	12' x 100'	6 Mil	34.4 lbs./roll
PLY620FR	20' x 100'	6 Mil	57.4 lbs./roll
PLY1020FR	20' x 100'	10 Mil	95.5 lbs./roll

Looking for other sizes? — 888-222-8499

DURA♦SKRIM® 2 (6 Mil - Clear)

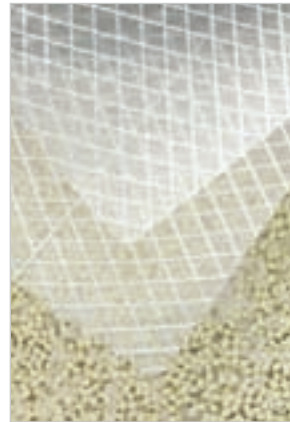

DURA♦SKRIM® 2 consist of two sheets of highstrength virgin polyethylene film laminated together with a third layer of molten polyethylene. A heavy-duty scrim reinforcement placed between these plies greatly enhances tear-resistance and increases service life. DURA♦SKRIM's heavy-duty diamond reinforcement responds to tears immediately by surrounding and stopping the tear.

Size: 20' wide x 100' long

Item# **PLY5CC**

DURA♦SKRIM® 2FR (6 Mil - Translucent, White Color)



DURA♦SKRIM® 2FR consist of two sheets of highstrength fire-retardant virgin film laminated together with a third layer of molten polyethylene. A heavy-duty scrim reinforcement placed between these plies greatly enhances tear resistance and increases service life. DURA♦SKRIM's fire-retardant films meet or exceed NFPA's 701 test, method 2 (Large Scale Requirements).

Size: 20' wide x 100' long

Item# **PLY5CCF**

T-55 ASFR – Anti-Static, Fire Retartant



Conforms to the following safety codes:

- Passes NFPA 701 Large Scale – “Standard Methods of Fire Tests for Flame-Resistant Textiles and Films.”
- Class I, Class A flame spread rating per UBC-42 and ASTM E-84.

Features

- Fire retardant to meet safety requirements in critical equipment and material areas.
- Multiple layers & cord reinforcement resist punctures and tears.
- Cold-crack resistance eliminates failures in cold temperatures.
- Low permeability greatly inhibits moisture transmission.
- Custom fabrication is available to meet your exact specifications.

Sizes: 4' x 100' to 40' x 100' in increments of 4' widths

Item# **PLYT55-ASFR**

Power Tools

M12™ CORDLESS LITHIUM-ION 3/8" DRILL DRIVER

- 2-Speed (0-1,500/0-400) All Metal Gear Box – Up to 35% faster drilling / fastening and Milwaukee durability.
- Powerful motor delivers 275 in-lbs. of torque – Up to 25% more torque.
- 3/8" Single Sleeve ratcheting metal chuck – Increased bit retention and durability.
- Lightweight and Compact – Tool belt portable at only 2.5 lbs. and 7-3/8".
- Integrated LED and Fuel Gauge.



Includes: Drill Driver, (2) M12™ RED LITHIUM™ batteries, 30-minute charger and carrying case.

Item# **MIL2410-22**

M12™ CORDLESS LITHIUM-ION 3/8" HAMMER DRILL DRIVER KIT

- Powerful motor delivers best in class 275 in-lbs of torque.
- Compact and Lightweight: 7-5/8" length, 2.8 lbs.
- 2-Speed Metal Gear Box: 0-22,500 bpm, 0-400 / 0-1,500 rpm.
- 3/8" Metal Single Sleeve Ratcheting Chuck.
- On-Board Fuel Gauge: Displays remaining run-time.
- Built-In LED Light: Illuminates work surface.



Includes: Drill Driver, (2) M12™ RED LITHIUM™ batteries, 30-minute charger and carrying case.

Item# **MIL2411-22**

M12™ CORDLESS LITHIUM-ION 1/4" HEX IMPACT DRIVER

- M12™ RED LITHIUM™ battery offers longer run-time and lighter weight.
- 0-2,000 RPM variable speed trigger.
- Battery fuel gauge displays remaining run-time.
- Built-in LED light illuminates work surface.



Includes: Cordless hex impact driver, (2) M12 RED LITHIUM™ batteries, M12™ charger and carrying case.

Item# **MIL2450-22**

M12™ CORDLESS LITHIUM-ION NO-HUB DRIVER

- Specific Torque Settings for 60 and 80 in-lbs – Fast accurate installation of no-hub couplings.
- Auto Shut-Off w/ LED Indicator.
- LED Calibration Indicator – Alerts user when calibration is needed (25,000 cycles).
- 0-750 RPM Drill Mode – Increased utility for general drilling and fastening.
- M12™ RED LITHIUM™ Battery – Fastens up to 300 steel clamps on a single charge.
- Compact/Lightweight Design – Reduces user fatigue at only 2.75 lbs.



Includes: Cordless no-hub coupling driver, (3) Shockwave™ sockets (1/4", 5/16", 3/8"), (2) M12™ RED LITHIUM™ batteries, 30-minute charger and carrying case.

Item# **MIL2455-22**

HACKZALL™ M12™ CORDLESS LITHIUM-ION RECIP SAW



- Only 11" and 2.6 lbs. for cutting in tight spaces
- M12™ RED LITHIUM™ Battery offers longer run-time and lighter weight.
- Keyless QUIK-LOK™ Blade Clamp allows for quick and easy blade changes.
- All-Metal Gear Case for added durability.
- Variable Speed Trigger for increased user control.
- Battery Fuel Gauge displays remaining run-time.
- Accepts both HACKZALL™ and SAWZALL® style blades.
- Built-In LED Light illuminates work surface.



Includes: Recip Saw, (2) M12™ RED LITHIUM™ batteries, 30-minute charger, (2) Hackzall™ blades and carrying case.

Item# **MIL2420-22**

M12™ CORDLESS SUB-COMPACT BAND SAW KIT

- One-Handed Cuts: Most compact size and lightest weight of any cordless band saw.
- Powerful motor cuts 3/4" EMT in 3 seconds, up to 150 cuts per charge with the XC battery.
- 1-5/8" Cut Capacity: For a wide range of applications.
- Meets OSHA Guarding Requirements: Suitable for one-handed use.
- LED Light: Highlights the cut line.
- Blade Tension Adjustment: Adjustable blade tracking.



Includes: Band Saw, (1) M12™ XC high capacity RED LITHIUM™ battery, 30-minute charger, (1) sub-compact portable band saw blade and carrying case.

Item# **MIL2429-21XC**

M12™ CORDLESS RATCHET KITS

- Compact Low-Profile Head Design: 3/4" head for extremely tight spaces.
- Powerful 12V motor delivers up to 30 ft-lbs of torque (35 ft-lbs for MIL2457-21).
- Superior Fastening Speed: 250 rpm.
- Variable Speed Metal Trigger: Greater control and durability.
- On Board Fuel Gauge: Displays remaining run-time.
- Built-in LED Light: Illuminates work area and tight dark spaces.
- Re-inforced steel housing for added durability and strong cranking forces.

Includes: Ratchet, (1) M12 RED LITHIUM™ battery, 30-minute charger and carrying case. The MIL2457-21 includes a 3/8" to 1/4" adapter.

Item# **MIL2456-21** (1/4" Ratchet)

Item# **MIL2457-21** (3/8" Ratchet)



Power Tools

M12™ CORDLESS LITHIUM-ION PVC SHEAR KIT

- Powerful Mechanism – Cuts up to 2" schedule 40 PVC in 3 seconds
- Ultra Sharp Blade with Pierce Point – No burrs or shavings to remove
- Offset Blade – Cuts PVC / PEX in-wall, in-ground or close to wall.
- Quick Return Blade – Increased productivity during repetitive cuts.
- All Metal Planetary Drive – Delivers over 200 cuts per charge.
- Stainless Steel Blade, Aluminum Jaw – Impact, water, rust resistant.
- Variable Speed Trigger – Controlled cut in warm or cold weather.
- On Board Fuel Gauge – Displays remaining run-time.



Includes: Cordless PVC shear, (1) 12V LITHIUM-ION battery, 30-minute charger and carrying case.

Item# **MIL2470-21**

M12™ CORDLESS LITHIUM-ION COPPER TUBING CUTTER

- Close quarter rotating cutting head cuts pipe in confined spaces.
- Automatic adjustment from 3/8" - 1" tubing.
- Auto Locking Mechanism delivers up to 200 cuts per charge.
- Water resistant sealed metal cutter head.
- Battery Fuel Gauge displays remaining run-time.
- Built-in LED light illuminates line of cut.
- 12V LITHIUM-ION battery for longer run-time and lighter weight.



Includes: Cordless copper tubing cutter, (2) 12V LITHIUM-ION batteries, 30-minute charger and carrying case.

Item# **MIL2471-22**

M12™ CORDLESS LITHIUM-ION GREASE GUN

- Powerful 12V motor delivers over 8,000 psi max operating pressure.
- Best in Class Run-Time: Dispenses up to 7 cartridges per charge.
- Superior Handle Balance and Ergonomics: Only 14" long and 7.2 lbs.
- Integrated Hose Storage and LED Fuel Gauge: Added user convenience and less down time.
- Air Bleeder Valve: Priming mechanism for quick flow.
- M12™ LITHIUM-ION System: Compatible with over 20 M12™ LITHIUM-ION tools for greater versatility in the workplace.
- Maximum Durability: Backed by a 5-year warranty.



Includes: Grease gun, (1) M12™ XC RED LITHIUM™ battery, 30-minute charger, 36" flex hose with spring guard, grease coupler and carrying case.

Item# **MIL2446-21XC**

M18™ CORDLESS LITHIUM-ION 2-TOOL COMBO KIT

- M18™ 1/2" Compact Drill/Driver delivers 425 In-lbs of torque and is only 4 lbs. and the 7-3/4" long M18™ 1/4" Hex Compact Impact Driver with the Milwaukee® 4-Pole frameless motor delivers 1400 in-lbs of torque.



Includes: Compact driver, 1/4" hex impact driver, (2) M18™ RED LITHIUM™ compact battery packs, M18™ charger and carrying case.

Item# **MIL2691-22**

M18™ CORDLESS LITHIUM-ION 2-TOOL COMBO KIT

- M18™ 1/2" Hammer Drill Driver with Milwaukee® 4-Pole Frameless Motor delivers 525 in-lbs of peak torque, 0-550/0-1,700 rpm, and 29,000 bpm.
- M18™ 1/4" Hex Compact Impact Driver featuring a Milwaukee® Designed Impact Mechanism for 1,400 in-lbs of torque.
- DPM™ – Overload protection prevents damage to the tool and battery.
- Works with M18™ XC high capacity RED LITHIUM™ batteries and M18™ compact RED LITHIUM™ batteries.



Includes: Hammer drill driver, 1/4" hex compact impact driver, (2) M18™ XC high capacity RED LITHIUM™ batteries, 1-hour charger and contractor bag.

Item# **MIL2697-22**

M18 FUEL™ 1/2" DRILL/DRIVER AND HAMMER DRILL/DRIVER KITS

- POWERSTATE™ Brushless motor delivers up to 725 in-lbs of torque with maximum sustained torque to complete the toughest of applications.
- REDLITHIUM™ Battery Technology: Superior pack construction, electronics and performance deliver more work per charge and more work over pack life than any battery on the market.
- REDLINK PLUS™ Intelligence: Provides optimized performance and overload protection using total system communication between tool, battery and charger.



Kits Include: Cordless Drill/Driver (MIL2603-22), Cordless Hammer Drill/Driver (MIL2604-22), (2) M18™ HIGH CAPACITY REDLITHIUM™ battery packs, multi-voltage charger, carrying case.

Item# **MIL2603-22** (1/2" Drill/Driver Kit)

Item# **MIL2604-22** (1/2" Hammer Drill/Driver Kit)

Power Tools

M18 FUEL™ 1/2" DRILL/DRIVER AND HAMMER DRILL/DRIVER KITS

- POWERSTATE™ Brushless motor delivers up to 650 in-lbs of torque with maximum sustained torque to complete the toughest of applications.
- REDLITHIUM™ Battery Technology: Superior pack construction, electronics and performance deliver more work per charge and more work over pack life than any battery on the market.
- REDLINK PLUS™ Intelligence: The most advanced system of cordless power tool electronics. Provides optimized performance and overload protection using total system communication between tool, battery and charger.



Kits Include: Cordless Drill/Driver (MIL2603-22CT), Cordless Hammer Drill/Driver (MIL2604-22CT), (2) M18™ COMPACT REDLITHIUM™ battery packs, multi-voltage charger, carrying case.

Item# **MIL2603-22CT** (1/2" Drill/Driver Kit)

Item# **MIL2604-22CT** (1/2" Hammer Drill/Driver Kit)

M18™ CORDLESS LITHIUM-ION 7/8" SDS PLUS ROTARY HAMMER KIT

- Powerful Hammer Mechanism: Delivers 1.8 ft-lbs of impact energy.
- Mechanical Clutch: Protects tool when bit binds up.
- AVS - Anti Vibration System: Delivers maximum comfort by minimizing vibration.
- 3-Mode Operation: Rotary hammer, hammer only and rotation only for maximum versatility.
- Variable Position Chisel Stop: Adjust for work in any orientation.



Includes: Rotary Hammer, (2) M18™ XC high capacity RED LITHIUM™ battery packs, charger, side handle, depth rod and carrying case.

Item# **MIL2605-22**

M18 FUEL™ 1/4" HEX IMPACT DRIVER KIT – XC BATTERIES

- Milwaukee® POWERSTATE™ brushless motor runs cooler, lasts longer, delivers up to 55% faster application speed.
- REDLINK PLUS™ Electronic Intelligence allows the operator to choose between 3 fastening modes with Milwaukee's proprietary DRIVE CONTROL™ feature.
- The Milwaukee® REDLITHIUM™ battery pack is the most durable pack on the market and provides up to 50% more run time.



Includes: Cordless 1/4" hex impact driver, (2) M18™ RED LITHIUM™ XC high capacity battery packs, 1-hour multi-voltage charger, belt clip and carrying case.

Item# **MIL2653-22**

M18™ CORDLESS LITHIUM-ION 1/4" HEX COMPACT IMPACT DRIVER



- M18™ XC High Capacity RED LITHIUM™ battery delivers longer life and run-time.
- 1/4" Hex Quick Change Chuck allows for easy bit changes.
- Milwaukee® Designed Impact Mechanism provides faster application speed.
- Milwaukee® 4-Pole Frameless Motor maximizes tool efficiency to increase run-time.
- Belt clip allows for easy portability.
- Battery fuel gauge displays remaining run-time.
- Built-in LED Light illuminates work surface.
- Variable speed trigger.



Includes: Cordless 1/4" hex compact impact driver, (2) M18™ XC high capacity RED LITHIUM™ batteries, 1-hour charger, belt clip and carrying case.

Item# **MIL2650-22**

M18™ CORDLESS LITHIUM-ION 1/2" HIGH TORQUE IMPACT WRENCH W/FRICTION RING KIT

- Milwaukee® Designed Impact Mechanism: Delivers 450 ft-lbs of torque.
- Compact Size, Lightweight: 8-7/8" Length and 6.7 lbs.
- Milwaukee® 4-Pole Frameless motor delivers maximum run-time.
- 1/2" Anvil w/Friction Ring: Provides quick and easy, one-handed socket changes.



Includes: Cordless 1/2" high torque impact wrench w/friction ring, (2) M18™ XC high capacity RED LITHIUM™ batteries, M18™ LITHIUM-ION battery charger and carrying case.

Item# **MIL2663-22**

M18™ CORDLESS LITHIUM-ION 5-3/8" METAL SAW KIT

- Exclusive 4-Pole frameless motor delivers up to 35% more cutting power.
- Compact, low-profile design for easy handling and increased control.
- Extra-Large cut guide, impact resistant window and LED light for more accurate cuts.
- Lightweight (5.8 lbs.) design for easier overhead cuts and less user fatigue.
- 30T METAL TECH™ Carbide-Tipped blade produces cool, burr-free cuts through EMT, strut, threaded rod, sheet metal, angle iron and other ferrous materials.
- Quickly and easily adjusts cutting depth from 1/8"-2" (tool-free).



Includes: Cordless 5-3/8" metal saw, (2) M18™ XC high capacity RED LITHIUM™ battery packs, 1-hour charger, 30T METAL TECH™ carbide-tipped blade, blade wrench and contractor bag.

Item# **MIL2682-22**

Power Tools

M18™ CORDLESS LITHIUM-ION BAND SAW KIT

- 45% Lighter than Deep Cut – 10.25 Lbs. compact lightweight design for cutting overhead and in tight places.
- 3-1/4" Cut Capacity – Single pass cut on 3" copper, 3" angle iron and 2-1/2" conduit.
- Tool-Free adjustable material shoe.
- LED Work Light – Illuminates the cut line in dark areas.
- Quickly change the blade by moving the material guide into the up position and depressing the blade ejection button.
- Drop resistant pulley guard.
- Cast aluminum gear case.



Includes: Cordless band saw, (2) M18™ XC high capacity RED LITHIUM™ batteries, 1-hour charger, blade and case.

Item# **MIL2629-22**

M18™ CORDLESS 10 OZ. CAULK AND ADHESIVE GUN KIT

- 950 lbs. of Dispensing Force – Milwaukee® built all metal gears deliver industry leading force for the highest viscosity materials.
- Variable Speed Trigger – Allows for maximum control of the flow rate and bead width.
- Constant Flow Technology – Steady material flow rate and even beads at all viscosity levels.
- Anti-Drip Mechanism – Instantly stops material from expelling upon trigger release.
- Rotating Quick-Change Collar – Accepts all Milwaukee® quick change configurations: 10 oz. carriage, quart-size carriage and 20 oz. sausage style barrels.
- 6-Setting Max Speed Dial – Optimize flow rate from 0-21 IPM (inches per minute) based on application.



Includes: Caulk gun, (1) M18™ compact RED LITHIUM™ battery, (1) 30-minute charger, (1) 10 oz. carriage, (1) 10 oz. plunger rod and piston assembly.

Item# **MIL2641-21CT**

3/8" MAGNUM® DRILL, 0-2500 RPM WITH ALL METAL CHUCK

- Powerful 7.0 amp motor, 0 to 2500 rpm, variable speed control.
- All metal Grip-Lok™ 2-sleeve keyless chuck for a stronger hold on the bit.
- All metal gear case and diaphragm.
- 10 ft. 2-wire rubber cord.
- 360° locking side handle.
- Ergonomic tactile grip and two finger trigger for user comfort and balance.



Includes: Drill and side handle.

Item# **MIL0201-20**

3/8" MAGNUM® DRILL, 0-2800 RPM WITH KEYLESS CHUCK

- 5.5 amp motor, 0 to 2800 rpm, trigger speed control with reversing.
- Heavy-duty industrial keyless chuck.
- 8 ft. 2-wire rubber cord.
- Exclusive brush cartridge system changes brushes in less than one minute.



Includes: Drill and side handle.

Item# **MIL0233-20**

1/2" MAGNUM® DRILL, 0-850 RPM

- Powerful 8.0 amp motor, 0 to 850 rpm, variable speed control.
- Heavy-duty keyed chuck.
- All metal gear case and diaphragm.
- 8 ft. 3-wire rubber cord.
- 360° locking side handle.
- Ergonomic textured grip and two finger trigger for user comfort and balance.



Includes: Drill, side handle and chuck key with holder.

Item# **MIL0299-20**

1/2" MAGNUM® DRILL, 0-950 RPM

- 5.5 amp motor, 0 to 950 rpm, trigger speed control with reversing.
- Heavy-duty industrial chuck.
- 8 ft. 3-wire QUIK-LOK® cord with easy detachment for storage and service.
- Exclusive brush cartridge system changes brushes in less than one minute.



Includes: Drill, side handle and chuck key with holder.

Item# **MIL0234-6**

1/2" MAGNUM® DRILL, 0-950 RPM WITH ALL METAL KEYLESS CHUCK

- 5.5 amp motor, 0 to 950 rpm, trigger speed control with reversing.
- Heavy-duty industrial single sleeve all metal keyless chuck and spindle lock.
- 8 ft. 3-wire Quik-Lok® cord with easy detachment for storage and service.
- Exclusive brush cartridge system changes brushes in less than one minute.



Includes: Drill and side handle.

Item# **MIL0235-21**

Power Tools

1/2" COMPACT DRILL, 450 RPM

- 1/2" Capacity in steel.
- 450 rpm, reversing.
- Powerful 7 amp motor.
- Heat treated gears are Helical-Cut for quiet performance.

Includes: Pipe handle.

Item# **MIL1660-6**



1/2" HOLE-HAWG® DRILL, 300/1200 RPM

- Handles up to 4-5/8" selffeed bit.
- Two speed: 300 and 1200 rpm, reversing.
- Powerful 7.5 amp motor.
- Powerful, yet compact for large hole drilling between joists and studs.

Includes: Pipe handle.

Item# **MIL1675-6**



1/2" SUPER HAWG® WITH CARRYING CASE



- Clutch in low speed.
- High operating speeds for maximum productivity.
- 90° left-right, Roto-Lok® handle for maximum operating comfort.
- Easy turn gear shift knob.
- Comfort grip switch handle and gear case with front T-bar handle.

Includes: Side handle and carrying case.

Item# **MIL1680-21**

1/2" PISTOL GRIP DUAL TORQUE HAMMER DRILL

- 1/2" Capacity, 7.5 amp motor.
- Trigger speed control in two ranges: 0-1350 rpm, 0-22,000 bpm, 0-2500 rpm, 0-40,000 bpm, reversing.
- Hammer with rotation or rotation only.
- Self-stop brush system.

Includes: Depth gauge, side handle and chuck key.

Item# **MIL5378-20**



1/2" IMPACT WRENCH WITH ROCKER SWITCH AND DETENT PIN SOCKET RETENTION



- 300 ft-lbs of torque – more torque saves time.
- AC/DC rocker switch for quick selection of forward/reverse.
- Powerful 7.0 amp motor, 1800 rpm and 2600 ipm (no load).
- Lightweight (6 lbs.) with balanced feel and cushioned grip.
- Pin detent system to securely retain sockets and adapters.

Item# **MIL9070-20**



5/8" SDS PLUS ROTARY HAMMER KIT

- Lightweight, 4.6 lbs: Reduces fatigue in overhead and horizontal drilling applications.
- Compact, 10.25" Length: Allows for work in tight spaces.
- Powerful 5.5 amp motor delivers 0-3,700 rpm and 0-4,400 bpm.
- Mechanical Clutch: Protects tool when bit binds up.
- AVS - Anti Vibration System: Delivers maximum comfort by minimizing vibration.
- 2-Mode Operation: Rotary hammer and rotation only for maximum versatility.

Includes: 5/8" Rotary hammer, side handle, depth rod, carrying case.

Item# **MIL5263-21**



7/8" SDS PLUS ROTARY HAMMER KIT

- Powerful, Lightweight Design: Delivers 1.8 ft-lbs of impact energy at only 5.8 lbs.
- Mechanical Clutch: Protects tool when bit binds up.
- Powerful 7.0 amp motor delivers 0-1,500 rpm and 0-5,625 bpm.
- 3-Mode Operation: Rotary hammer, hammer only and rotation only for maximum versatility.
- Variable Position Chisel Stop: Allows Steel to be adjusted for work in any orientation.

Includes: Rotary hammer, side handle, depth rod and carrying case.

Item# **MIL5262-21**



**If you don't find what you need,
Call Abatix at 888-222-8499.**

Power Tools

1" COMPACT SDS PLUS ROTARY HAMMER (Anti-Vibration System)

- High power 7.0 amp reversible motor delivers 2.0 ft-lbs of impact energy, 0-5,980 bpm and 0-1,400 rpm.
- All metal gear case and block construction for optimal bearing and gear seating.
- Anti-Vibration System, soft grip handle and two-finger trigger for optimal operator comfort.
- Three modes of operation - Hammer Drill / Drill / Chipping for maximum versatility.
- Rotating Brush Plate for equal power in forward and reverse for easy removal of jammed bits and extended brush life.
- Compact and lightweight, L-shape design provides excellent balance and positions hand directly behind the bit for maximum control especially in overhead drilling applications.



Includes: Rotary hammer, depth gauge, side handle and carrying case.
Item# **MIL5363-21**

1-9/16" SDS MAX ROTARY HAMMER

- Powerful 10.5 amp motor delivers 450 rpm and 3,000 bpm.
- Powerful Hammer Mechanism: Delivers 5.5 ft-lbs (7.5J) of impact energy for drilling in hard aggregate.
- CPT™ - Constant Power Technology: Delivers consistent performance in tough applications.
- Mechanical Clutch: Protects the tool when the bit binds up.
- 2-Mode Operation: Rotary hammer and hammer only for maximum versatility.
- 12-Position Chipping Adjustment: Allows the user to maintain the desired hammer position while chipping in any orientation.



Includes: Rotary hammer, side handle and carrying case.
Item# **MIL5317-21**

11 AMP 4-1/2" SMALL ANGLE GRINDER PADDLE

- Powerful 11 amp, 11,000 rpm motor provides maximum performance and durability.
- Overload Protection: Maximizes motor life.
- Electronic Clutch: Extends tool life and prevents bind-up.
- Tool-Free Accessory Change: Easily change "All Accessories."
- Tool-Free Adjustable Guard: Quick guard installations, adjustments.
- Advanced Airflow System: Maximizes airflow and reduces debris ingress, improving motor life and performance.
- Debris Baffles – protect internal components by deflecting damaging debris out of the airflow at the intake vents.
- Compatible with multiple Grinder Guards and Flanges.



Includes: Grinder, side handle, Type 27 guard, grinding wheel, spanner wrench, flanges and contractor bag (MIL6146-30 only).

Item# **MIL6146-30** Lock-On Switch
Item# **MIL6146-31** No-Lock Switch

13 AMP 5" SMALL ANGLE GRINDER PADDLE, NO-LOCK

- Powerful 13 amp, 11,000 rpm motor.
- Overload Protection.
- Electronic Clutch.
- Constant Power Technology™: Maintains constant speed under load.
- Tool-Free Accessory Change: Easily change "All Accessories."
- Tool-Free Adjustable Guard: Quick guard installations, adjustments.
- Advanced Airflow System: Maximizes airflow and reduces debris ingress, improving motor life and performance.
- Anti-Vibration Side Handle.
- Soft Start: Allows maximum control at start-up.
- Compatible with multiple grinder guards and flanges.



Includes: Grinder, side handle, Type 27 guard, spanner wrench and flanges.
Item# **MIL6117-31**

15 AMP 7"/9" LARGE ANGLE GRINDER W/ LOCK-ON

- 15.0 Amp, 4.2 HP Motor – high overload protection and power.
- 6,000 RPM.
- Debris Baffles protect internal components.
- External Brush Doors reduce service time by providing easy access.
- Soft-Grip Main Handle – provides better control and comfort.
- Tool Free, Burst Resistant Guard – quickly adjust the guard.
- 7" and 9" Type 27 Guard included for added productivity.
- Compatible with multiple grinder guards and flanges.



Includes: Grinder, side handle, 7" and 9" Type 27 guard, spanner wrench and flanges.
Item# **MIL6088-30**

SAWZALL® RECIP SAW KIT

- Powerful 12 amp motor delivers 0-3,000 spm for high performance cutting.
- 3/4" stroke length.
- Gear Protecting Clutch.
- Counter Weighted Mechanism: Provides reduced vibration.
- QUIK-LOK™ Blade Clamp: Provides fast, tool-free blade changes.



Includes: Recip saw and carrying case.
Item# **MIL6509-31**

13 AMP ORBITAL SUPER SAWZALL® RECIP SAW

- 13 Amp Milwaukee built motor.
- Orbital cutting action.
- Variable speed trigger, 0-3000 spm.
- 1-1/4" Stroke.
- Counter Balanced/Gear Protection Systems.
- QUIK-LOK™ Blade Clamp.



Includes: Recip saw and carrying case.
Item# **MIL6536-21**

Power Tools

DEEP CUT VARIABLE SPEED BAND SAW KIT

- Powerful 11 amp motor with CPT™ provides maximum performance and durability.
- Job Site Armor™ Technology: Proprietary composite material and crush zone barriers provide long lasting rugged protection.
- All Metal Direct Drive: Delivers maximum tool life with all metal direct drive gearing system, while requiring less servicing than a chain drive.
- Gear Protecting Clutch extends gear and motor life by absorbing high impact forces caused by blade lock-ups.
- CPT™ Constant Power Technology: Maintains cut speed in the toughest applications for optimal performance.
- Revolutionary Cut Visibility: Slimmer motor housing increases user line of site delivering superior cut accuracy.
- Balanced Body Design.
- Lighter Weight, 14.5 Lbs.
- LED Light: Illuminates work surface.
- Button actuated tool-free design allows user to quickly adjust from an extended shoe to no shoe in seconds.
- Industry's Largest Cut Capacity: Versatility to cut up to 5" x 5" material in one pass and adjustable shoe allows for less tool rotation when cutting material above 5".
- Debris Protection System.



Includes: Band saw and carrying case.

Item# **MIL6232-21**

Item# **MIL6238-21** AC/DC

8" METAL CUTTING SAW

- Dry-cut technology provides faster, cleaner, more affordable metal cutting.
- Durable blade shield with integral chiptank deflects/collects hot chips and sparks.
- Plunge lever for fast, effective plunge cuts.
- Exclusive quick-release shield latch for fast waste disposal and blade changes.
- 2-9/16" cut depth for one-pass cuts through most common materials.
- Powerful 13.0 amp, 3,700 rpm motor.
- Premium cermet-tipped blades cut faster, cleaner, and longer than other carbide-tipped or friction blades.



Includes: Hex blade wrench and circular saw blade.

Item# **MIL6370-20**

18 GAUGE SHEAR

- 6.8 amp Milwaukee motor, trigger speed control: 0-2,500 rpm spindle speed.
- 360° swivel head.
- Ergonomic tactile grip for optimal user comfort.
- 10 ft. flexible durable runner cord.



Includes: Shear and hex wrench.

Item# **MIL6852-20**

DUAL TEMPERATURE HEAT GUN

- Dual temperature 570°F and 1000°F, 11.6 amp motor.
- Unique impact resistant heating element.
- Efficient soft air velocity increases surface temperature much faster than conventional hot air heat guns.
- Three position rocker switch – off, high and low.



Item# **MIL8975-6**

KSV-432 VACUUM SAW



The cast aluminum saw head accepts the nose from your shop vacuum to collect debris as you cut. Great for close quarters where plunge or straight cut-outs are needed.

Features

- 5.0 amp pistol grip, variable speed, 2500 RPM motor.
- Replaceable tool steel saw blades.
- Cuts C.R. mild steel 16 gauge and lighter, plastic and other rigid materials up to 1/2" and aluminum to 1/8".
- Great for cutting Drywall, fiberglass and plaster products.
- Leaves a milled, ready to fabricate finish without burning material.
- Lightweight and easily maneuverable, dust free cutting.
- Plunge cuts into the middle of the material.

Specifications

Amps	5.0
RPM	0-2500
Power source	120 volts
Saw unit	KSV-32
Maximum depth of cut	5/8"
C.R. mild steel	16 gauge
Aluminum	1/8"
Rigid materials	1/2"
Length	17"
Weight	7 lbs.



Saw Blades

Diameter	Part No.	Bore	Teeth/Inch	Max. Depth of Cut
2-1/2"	157-600	7/16"		5/8"
2-1/2"	157-66	7/16"	0.1	5/8"

Power Tools

12V MAX* 1/4" SCREWDRIVER KIT

- Compact, lightweight design fits into tight areas.
- 3 LED Lights provide visibility without shadows.
- One-handed loading 1/4" hex chuck accepts 1" bit tips.
- Includes: (2) 12V MAX* lithium ion battery packs, fast charger, bit tip, belt hook and contractor bag / Tool weight: 2.2 lbs.

Item# **DWDCF610S2**

**Maximum initial battery voltage (measured without a workload) is 12 volts. Nominal voltage is 10.8.*



12V MAX* 1/4" IMPACT DRIVER KIT

- Compact, lightweight design fits into tight areas.
- 3 LED Lights provide visibility without shadows.
- One-handed loading 1/4" hex chuck accepts 1" bit tips.
- Includes: (2) 12V MAX* lithium ion battery packs, fast charger, belt hook & impact ready bit tip and contractor bag.
- Tool weight: 2.3 lbs.

Item# **DWDCF815S2**



12V MAX* 3/8" DRILL DRIVER KIT

- Compact, lightweight design fits into tight areas.
- Two speed transmission for optimal speed and torque control.
- LED light provides visibility in dark areas.
- Belt hook included for portability.
- Includes: (2) 12V MAX* lithium ion battery packs, fast charger, belt hook and contractor bag.
- Tool weight: 2.4 lbs.

Item# **DWDCD710S2**



12V MAX* 3/8" IMPACT WRENCH KIT

- Compact, lightweight design fits into tight areas.
- 3 LED Lights provide visibility without shadows.
- 3/8" Hog ring anvil; Fast socket changing.
- 1150 in-lbs of torque; Power for tightening and loosening.
- Includes: (2) 12V MAX* lithium ion battery packs, fast charger and contractor bag.
- Tool weight: 2.3 lbs.

Item# **DWDCF813S2**

**Maximum initial battery voltage (measured without a workload) is 12 volts. Nominal voltage is 10.8.*



1/2" (13MM) 12V CORDLESS XRP™ DRILL/DRIVER KIT



- XRP™ extended run-time batteries provide long run-time and battery life.
- Patented 3-speed all-metal transmission matches the tool to task for fastest application speed and improved run time.
- Heavy-duty 1/2" ratcheting chuck helps prevent bits from slipping and falling out.
- LED worklight provides increased visibility in confined spaces.
- High power, high efficiency motor delivers 285 unit watts out of max power for superior performance in all drilling and fastening applications.
- Includes: 1-Hour charger, (2) 12V XRP™ batteries and kit box.
- Tool weight: 5.25 lbs.

Item# **DWDCD910KX**



18V 7/8" (22MM) CORDLESS SDS HAMMER KIT

- SHOCKS™ - Active Vibration Control reduces vibration up to 70%.
- Compact L-shape design allows access in tight spaces.
- 1.7 ft-lbs impact energy.
- Variable speed reversible switch – greater control.
- Factory-set clutch reduces sudden, high torque reactions if bit jams.
- Electro-pneumatic hammer mechanism for fast penetration and low vibration.
- 18V high performance battery pack – long run-time and battery life.
- Includes: 1-Hour charger, (2) 18V XRP™ batteries, 360° side handle, depth rod and kit box / Tool weight: 7.6 lbs.

Item# **DWDC212KA**



18V CORDLESS RECIPROCATING SAW KIT

- 1-1/8" Stroke length for faster cutting speed.
- 0-3,000 spm for faster cutting speed.
- 4-Position blade clamp allows for flush cutting and increased versatility.
- Keyless lever-action blade clamp for quick and easy blade changes.
- Pivoting adjustable shoe with open top for maximum visibility.
- Anti-slip comfort grip provides increased comfort and control.
- Variable speed with trigger lock for increased blade control.
- XRP™ extended run-time batteries provide long run-time and battery life.
- Includes: (1) 18V XRP™ battery, 1-hour charger and kit box.
- Tool weight: 8.2 lbs.

Item# **DWDC385K**





Power Tools

24V 7/8" (22MM) CORDLESS SDS HAMMER KIT

- Variable speed reversible switch avoids air bubbles when mixing mud and offers greater control when drilling.
- Factory-set clutch reduces sudden, high torque reactions if bit jams.
- Electro-pneumatic hammer mechanism for fast penetration and low vibration.
- SHOCKS™ - Active Vibration Control reduces vibration up to 70%.
- Compact L-shape design allows access in tight spaces.
- 1.7 ft-lbs impact energy.
- Includes: 1-Hour charger, (2) 24V batteries, 360° side handle, depth rod and kit box / Tool weight: 8.4 lbs.



Item# **DWDC223KA**

1/2" (13MM) 36V CORDLESS LI-ION HAMMERDRILL/DRILL/DRIVER KIT

- DEWALT® built high power, high efficiency motor delivers 750 unit watts out of max power for superior performance.
- DEWALT® exclusive lithium ion cells offer long battery life and durability: 2,000 recharges.
- Patented 3-speed all-metal transmission matches the speed to the application.
- Heavy-duty 1/2" self-tightening chuck tightens throughout operation.
- Anti-slip comfort grip provides increased comfort and control.
- Includes: 1-Hour charger, (2) 36V Li-Ion batteries, 360° side handle and kit box / Tool weight: 6.75 lbs.



Item# **DWDC901KL**

1/2" (13MM) 36V CORDLESS LI-ION IMPACT WRENCH KIT

- DEWALT®-built high torque, high efficiency motor with replaceable brushes delivers maximum performance in all fastening applications.
- DEWALT® exclusive lithium ion cells offer long battery life and durability: 2,000 recharges.
- Preferred rocker switch design for fast and easy forward and reverse.
- Patented all-metal anvil provides durability and prevents shearing.
- Anti-slip comfort grip provides increased comfort and control.
- High speed all-metal transmission delivers 1,400 rpm for increased productivity.
- Includes: 1-Hour charger, (2) 36V Li-Ion packs and kit box.
- Tool weight: 7.5 lbs.



Item# **DWDC800KL**

36V 1" (25MM) CORDLESS LI-ION SDS ROTARY HAMMER KIT

- SHOCKS™ - Active Vibration Control reduces vibration up to 70%.
- Compact L-shape design allows access in tight spaces.
- 1.9 ft-lbs impact energy.
- DEWALT®-built high torque, high efficiency motor delivers maximum performance.
- DEWALT® exclusive lithium ion cells offer long battery life and durability: 2,000 recharges.
- Variable speed reversible switch delivers increased versatility.
- Factory-set clutch reduces sudden, high torque reactions if bit jams.
- Electro-pneumatic hammer mechanism for fast penetration and low vibration.
- Includes: 1-Hour charger, (2) 36V Li-Ion batteries, 360° side handle, depth rod and kit box / Tool weight: 7.8 lbs.



Item# **DWDC233KL**

36V CORDLESS LI-ION RECIPROCATING SAW KIT

- 1-1/8" Stroke length and 0-3,000 spm for fast cutting.
- 4-Position keyless blade clamp allows quick blade change, flush cutting, and versatility.
- Anti-slip comfort grip.
- 3-Position adjustable shoe for adjusting depth of cut and extends blade life.
- DEWALT® exclusive lithium ion cells offer long battery life and durability: 2,000 recharges.
- DEWALT®-built high torque, high efficiency motor with electric brake powers through the toughest applications.
- Includes: (1) 36V Li-Ion battery, 1-hour charger and kit box.
- Tool weight: 8.4 Lbs.



Item# **DWDC305K**

4-1/2" (114MM) 36V CORDLESS LI-ION CUT-OFF TOOL KIT

- 6,500 rpm for fast cutting speed.
- Convenient trigger switch with lock-off button for easier gripping.
- 2-Position side handle offers greater comfort and control.
- Quick-Change™ Wheel Release allows tool free wheel removal.
- Low profile, jam-pot gear case provides precise gear alignment for a smoother, quieter transmission while allowing access to tight spaces.
- DEWALT® exclusive lithium ion cells offer long battery life and durability: 2,000 recharges.
- Includes: 1-Hour charger, (2) 36V Li-Ion batteries, Type 27 guard, Type 1 guard, wrench, (2) matched flanges, Type 27 (grinding) wheel, Type 1 (cutting) wheel, side handle and kit box.
- Tool weight: 7.2 lbs.



Item# **DWDC415KL**

Power Tools

12V MAX* CORDLESS LI-ION SCREWDRIVER / IMPACT DRIVER COMBO KIT

- DCF610 12V MAX* screwdriver features 1/4" one hand loading hex chuck.
- DCF815 12V MAX* 1/4" impact driver features 3 LED lights to provide visibility without shadows.
- Includes: Screwdriver, impact driver, (2) 12V MAX* Li-Ion batteries, fast charger, (2) bit tips, (2) belt hooks and contractor bag.



Item# **DWDCK210S2**

12V MAX* CORDLESS LI-ION DRILL/DRIVER / IMPACT DRIVER COMBO KIT

- DCD710 12V MAX* 3/8" drill/driver features two speed transmission (0-400 / 0-1,500).
- DCF815 12V MAX* 1/4" impact driver features 3 LED lights to provide visibility without shadows.
- Includes: Drill/driver, impact driver, (2) 12V MAX* Li-Ion batteries, fast charger, bit tip, (2) belt hooks and contractor bag.



Item# **DWDCK211S2**

18V CORDLESS XRP™ HAMMERDRILL / RECIPROCATING SAW COMBO KIT

- DCD950 18V XRP™ cordless hammerdrill with patented 3-speed all-metal transmission and 1/2" metal ratcheting chuck with carbide inserts delivers 450 units watts out of maximum performance, faster application speed, and superior bit retention.
- DC385 18V cordless reciprocating saw with keyless blade clamp allows for quick blade change without touching blade or reciprocating shaft.
- Includes: 1/2" Hammerdrill, reciprocating saw, (2) 18V XRP™ batteries, 1-hour charger, 360° side handle and contractor bag.



Item# **DWDCK251X**

*Maximum initial battery voltage (measured without a workload) is 12 volts. Nominal voltage is 10.8.

18V CORDLESS XRP™ 4-TOOL COMBO KIT

- DCD950 18V XRP™ cordless hammerdrill with patented 3-speed all-metal transmission and 1/2" metal ratcheting chuck with carbide inserts delivers 450 units watts out of maximum performance, faster application speed, and superior bit retention.
- DC390 18V circular saw with 6-1/2" carbide blade can cut 2x4's at a 45° angle in a single pass.
- DC385 18V cordless reciprocating saw with keyless blade clamp allows for quick blade change without touching blade or reciprocating shaft.
- DW919 18V flexible floodlight provides hands-free use.
- Includes: Hammerdrill, circular saw, reciprocating saw, flexible floodlight, (2) 18V XRP™ batteries, 1-hour charger, 360° side handle, carbide tipped blade and contractor bag.



Item# **DWDCK450X**

36V CORDLESS LI-ION HAMMERDRILL/RECIPROCATING SAW COMBO KIT

- DC901 36V 1/2" hammerdrill/drill/driver with 1/2" self-tightening chuck and patented 3-speed all-metal transmission.
- DC305 36V cordless reciprocating saw with 4-position keyless blade clamp allows for flush cutting and increased versatility.
- DEWALT® exclusive lithium ion cells offer long battery life and durability: 2,000 recharges.
- Includes: Hammerdrill/drill/driver, reciprocating saw, (2) 36V Li-Ion batteries, 1-hour charger, 360° side handle and contractor bag.



Item# **DWDCX6210**

36V SDS ROTARY HAMMER KIT AND DUST EXTRACTION SYSTEM

- DC233 36V 1" SDS rotary hammer with SHOCKS™ - Active Vibration Control reduces vibration while increasing user comfort and productivity.
- D25302DH dust extraction system designed for cordless convenience.
- DEWALT® exclusive lithium ion cells offer long battery life & durability: 2,000 recharges.
- Includes: SDS rotary hammer, dust extraction system, 1-hour charger, (2) 36V lithium ion battery packs and kit box.



Item# **DWDC233KLDH**

Power Tools

1/2" (13MM) VSR DRILL

- 7.8 Amp / 0-850 rpm.
- 600 Watts.
- Helical-cut steel, heat-treated steel gears.
- Metal gear housing.
- Two-finger, rubber trigger.
- 360° Side handle.
- Tool weight: 4.2 lbs.
- Includes: Chuck key with holder.

Item# **DW235G**



1" D-HANDLE THREE MODE SDS HAMMER

- 2.5 ft-lbs of impact energy.
- 8.0 Amp motor.
- Reverse feature.
- 0-1,150 rpm.
- 0-4,300 bpm.
- Variable speed.
- Factory-set clutch reduces sudden, high torque reactions if bit jams.
- 360° Side handle adjusts easily for preference or use in tight spaces.
- Tool weight: 6.1 lbs.

Item# **DWD25213K**



1-3/4" SDS MAX COMBINATION HAMMER KIT W/ SHOCKS® & CTC®

- 13.5 Amp motor, overload protection; 210-415 rpm; 1430-2840 bpm.
- 9.5 ft-lbs of impact energy.
- SHOCKS – Active Vibration Control® - 50% reduction.
- Complete Torque Control (CTC)® – Patented 2-stage clutch provides maximum control in bind up situations.
- 360° Side handle / Rear handle mount.
- Trigger lock-on reduces user fatigue while chipping.
- Includes: Kit box and users guide / Tool weight: 15.1 lbs.

Item# **DWD25602K**



1-3/4" SPLINE COMBINATION HAMMER KIT WITH CTC®

- 13.5 Amp motor provides maximum performance and overload protection.
- 9.5 ft-lbs of impact energy.
- Complete Torque Control (CTC)® – Patented 2-stage clutch.
- SHOCKS – Active Vibration Control® - 50% reduction.
- Electronic variable speed.
- Trigger lock-on.
- Rear handle mount / 360° side handle.
- Includes: Kit box and users guide / Tool weight: 15.5 lbs.

Item# **DWD25651K**



1-7/8" SDS MAX COMBINATION HAMMER KIT WITH CTC®

- SHOCKS – Active Vibration Control® reduces vibration up to 50% while increasing user comfort and productivity.
- Complete Torque Control (CTC)® – Patented 2-stage clutch provides maximum control in bind up situations.
- 13 Amp motor provides maximum performance and overload protection; 137-275 rpm; 1260-2520 bpm.
- 11.7 ft-lbs of impact energy.
- Rear handle mount.
- Trigger lock-on.
- Easy access to switch, motor, cordset, brushes and gear case.
- Includes: Kit box, 360° side handle and users guide.
- Tool weight: 17.5 lbs.

Item# **DWD25712K**



4,000 RPM VSR DRYWALL SCRUGUN W/ 50 FT. CORD AND TWIST LOCK

- 6.3 Amps / 0-4,000 rpm.
- 81 in-lbs torque.
- Metal gear case.
- 50' Twist lock cordset.
- Depth-sensitive, "set and forget" nosepiece.
- Rubber grip and two-finger trigger.
- Helical-cut steel, heat-treated steel gears.
- Lightweight with excellent ergonomics.
- Tool weight: 3.1 lbs.

Item# **DW272WT**



1/2" (13MM) STUD & JOIST DRILL KIT

- 100% Ball-bearing construction.
- Mechanical-slip clutch in low gear.
- Adjustable front handle and 2-position side handle.
- Mechanically controlled 2-speed to match rpm/torque to application requirement / Triple gear reduction.
- Includes: Chuck key with holder, 2-position side handle, bail handle and kit box / Length: 21" / Tool weight: 13.5 lbs.

Item# **DW124K**



Abatix has the right power tool for every job. If you don't find exactly what you need in this catalog, please ask – 888-222-8499.

Power Tools

10.0 AMP RECIPROCATING SAW KIT

- 4-Position blade clamp allows for flush cutting and increased versatility.
- Powerful 10.0 Amp motor designed for heavy-duty applications.
- Keyless lever-action blade clamp for quick, easy blade changes.
- 0-2,800 spm and 1-1/8" stroke length deliver fast cutting.
- Variable speed trigger.
- Includes: Carry case and instruction manual.
- Tool weight: 7.0 lbs.



Item# **DW304PK**

DEEP CUT VARIABLE SPEED BAND SAW KIT

- Rubber bumpers protect casting from jobsite abuse.
- Lightweight and well-balanced.
- Sight light.
- 6.0 Amp motor.
- 4-3/4" Deep cut capacity for round or rectangular stock.
- Dual bearing blade guide rollers.
- Adjustable material guide.
- Ergonomic soft grip back handle.
- Externally replaceable brushes.
- Speed control knob.
- Includes: Hex wrench, standard 44-7/8"x12"x.020" blade and kit box / Tool weight: 15.0 lbs.



Item# **DWD28770K**

14" CHOP SAW W/ QUIK-CHANGE™ KEYLESS BLADE CHANGE

- Powerful 15.0 Amp / 5.5 HP (maximum motor HP) motor provides more overload capacity.
- QUIK-CHANGE™ Blade Change System.
- Exclusive QUIK-FENCE™ tool-free, 45° adjustable fence allows for fast and accurate angle cuts.
- Quick-Lock Vise.
- Soft start extends gear and motor life.
- Ergonomically designed "D" handle.
- Extra wide solid steel base with four pre-drilled holes – easy to bolt down to any work bench.
- Heavy-duty lock down pin and compression spring.
- Spindle Lock – make wheel changes quickly and easily.
- Large cutting capacity (5" round / 4-1/2" x 6-1/2" rectangle).
- Adjustable spark guard allows user to channel sparks.
- Easily accessible brushes – minimize downtime.
- Includes: 14" Abrasive wheel, fence wrench and tool-free flange system / Tool weight: 39.0 lbs.



Item# **DWD28715**

4-1/2" (115MM) SMALL ANGLE GRINDER

- 10.0 Amp AC/DC, 11,000 rpm motor designed for faster material removal and higher overload protection / 1.6 HP.
- Dust Ejection System™ provides durability by ejecting damaging dust and debris particles that enter the tool through the air intake vents.
- Low profile, jam-pot gear case provides precise gear alignment for a smoother, quieter transmission while allowing access to tight spaces.
- One-piece brush arm prevents brush hang-up due to dust ingestion.
- Quick-Change™ Wheel Release allows tool free wheel removal without need for a wrench.
- Keyless adjustable guard provides tool-free guard adjustments, increasing productivity.
- Vibration-reducing side handle increases comfort for extended use applications.
- Auto-off brushes shut the tool down when the brushes need replacing to avoid tool damage.
- Oversized, protected spindle lock button provides easier and quicker wheel changes.
- Paddle switch with safety lock-off prevents accidental start up.
- Matching wheel flanges allow the use of common accessories.
- Includes: 2-Position handle, keyless adjustable guard and wrench.
- Length: 11-1/4" / Tool weight: 4.6 lbs.



Item# **DWD28402**

7" (180MM) LARGE ANGLE GRINDER

- High power 4 HP (maximum motor HP) 6,000 rpm motor with overload protection provides higher operating speeds under load.
- Epoxy coated field and armature provide long service life against abrasion from airborne debris.
- Keyless adjustable guard provides tool-free guard adjustments, increasing productivity.
- Low profile gear case allows for work in tight areas.
- Automatic turn-off brushes shut down the tool when brushes need to be changed to avoid tool damage.
- 5-Position side handle provides improved ergonomics for specific applications.
- 2-Wire double insulated 'S' jacket rubber cord provides increased durability and life in hot and cold climates.
- 6,000 rpm speed is designed for versatility in a variety of applications.
- Lightweight design increases productivity in extended use applications.
- Includes: 7" Guard and 5-position side handle.
- Length: 19.2" / Tool weight: 13.15 lbs.



Item# **DWD28494S**

Protection, Eye & Face - Headgear/Faceshields

ALUMINUM RIM 5-SYSTEM CAM LOCK HEADGEAR BRACKET



(Shown with Faceshield)

- Features
- Accepts most manufacturers' hard hats.
 - Accepts most Universally punched faceshields.
 - Z87+, AS / NZS 1337 compliant.

Item# **CRW102**

RATCHET TAKE-UP HEADGEAR WITH ADJUSTABLE HEADBAND



(Shown with Faceshield)

- Features
- Accepts most manufacturers' hard hats.
 - Accepts most Universally punched faceshields.
 - Z87+, AS / NZS 1337 compliant.

Item# **CRW103**

MCR FACESHIELDS

- 5-System hole punched, designed to fit Crews Headgear.
- Accepts most manufacturers' cam lock headgear.
- Available in Polycarbonate and PETG Material.
- Faceshields available in select sizes, thickness and shades.
- Material: PETG with Aluminum Bound.
- All lens provide 99.9% UV protection.
- Meets or exceeds ANSI Z87+.



Clear, Polycarbonate 8" x 15.5", .040 thick.

Item# **CRW181540**



Dark green, Polycarbonate 8" x 15.5", .040 thick.

Item# **CRW181542**



Clear, PETG material 8" x 15.5", .040 thick.

Item# **CRW181640**



Clear, Aluminum bound, PETG material 8" x 15.5", .040 thick.

Item# **CRW181640A**

Protection, Eye & Face - Goggles



GENERAL PURPOSE ECONOMY GOGGLES

Features

- PVC body permits a comfortable fit over prescription eyewear.
- Available in vented, perforated, chemical splash, ventless styles.
- Protects against impact.
- Some styles are treated with our exclusive Duramass® scratch-resistant coating.
- Meets or Exceeds ANSI Z87+ / Clear frame / Clear lens.



Item#	Description
CRW2230R	Indirect ventilation, adjustable rubber strap
CRW2235R	Indirect ventilation, anti-fog lens with rubber strap
CRW2237R	Ventless frame, anti-fog lens
CRW2120	Perforated frame, small size
CRW2220	Perforated frame, regular size
CRW2220R	Perforated frame, rubber strap
CRW2225R	Perforated frame, anti-fog lens with rubber strap

STRYKER™ GOGGLES – Stylish goggle with anti-fog coating

Features

- Indirect vent / Adjustable strap.
- Treated with our exclusive Duramass® AF4 anti-fog coating.
- Meets or Exceeds ANSI Z87+.
- Frame color - Smoke.



Item#	Description
CRW2310AF	Stryker™, Clear anti-fog lens with rubber strap
CRW2312AF	Stryker™, Gray anti-fog lens with rubber strap
CRW2320AF	Stryker™, Clear anti-fog lens with elastic strap
CRW2322AF	Stryker™, Gray anti-fog lens with elastic strap

Protection, Eye & Face - Accessory

LENS CLEANING STATION



Includes

- 2 Boxes of 300 tissues.
- 1 (8 oz.) bottle of anti-fog.
- Anti-static cleaning spray.

Item# **CRWLCS1**

LENS CLEANING TOWELETTES



Individually packaged anti-fog, anti-static lens cleaning towelettes. 100 per box.

Item# **ABXLCT**

EXPERIENCE THE DIFFERENCE

Protection, Eye & Face - Safety Glasses



YUKON® – Exceptional coverage

Features

- Dielectric / Integral brow guard and vented side shields.
- Meets or Exceeds ANSI Z87+.
- Clear uncoated lens, clear frame.

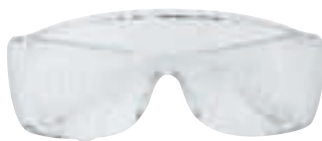

Item# **CRW9800** (Bulk Packed, 144 pr.)

BEARKAT® – Available in regular and small sizes for comfortable fit

Features

- Single wraparound lens design.
- Flexible temple design.
- Polycarbonate lens.
- Non-slip rubber head grips.
- Filters 99% of U.V. radiation.
- Meets military MIL-PRF-31013 clause 3.5.1.1 for high velocity impact protection and exceeds ANSI Z87+.
- Temple color - Black.



Item#	Description
CRWBK110	BearKat®, clear lens, frost frame
CRWBK110AF	BearKat®, clear anti-fog lens, frost frame
CRWBK112	BearKat®, gray lens, frost black frame
CRWBK112AF	BearKat®, gray anti-fog lens, frost black frame
CRWBK113	BearKat®, light blue lens, frost blue frame
CRWBK114	BearKat®, amber lens, translucent yellow frame
CRWBK117	BearKat®, silver mirror lens, frost black frame
CRWBK119	BearKat®, I/O clear mirror lens, frost frame
CRWBK210	BearKat®, clear lens, frost frame (small)
CRWBK212	BearKat®, gray lens, frost black frame (small)
CRWBK213	BearKat®, light blue lens, frost blue frame (small)
CRWBK219	BearKat®, I/O clear mirror lens, frost frame (small)
CRWBK118	BearKat®, blue mirror, smoke frame

CHECKMATE® – Maximum style, maximum protection

Features

- Exclusive Duramass® scratch-resistant and Duramass® anti-fog lens coating.
- Flexible bayonet temple design and universal nosebridge for a comfortable fit during long use.
- Strong, lightweight polycarbonate frame.
- Near total seal of eye orbit assures the highest level of protection.
- Filters 99% of U.V. radiation.
- Meets or Exceeds ANSI Z87+.



Item#	Description
CRWCK100	Checkmate®, clear uncoated lens, clear frame
CRWCK110	Checkmate®, clear lens, clear frame
CRWCK110AF	Checkmate®, clear anti-fog lens, clear frame
CRWCK117	Checkmate®, silver mirror lens, frost black frame
CRWCK118	Checkmate®, rainbow mirror lens, frost black frame
CRWCK119	Checkmate®, I/O clear mirror lens, clear frame
CRWCK112	Checkmate®, gray lens, frost black frame
CRWCK114	Checkmate®, amber lens, translucent yellow frame

CHECKLITE® – The look you want at a reasonable price

Features

- Exclusive Duramass® scratch-resistant and Duramass® anti-fog lens coating.
- Flexible spatula temple design for comfortable fit for long use.
- Strong, lightweight polycarbonate lens.
- Near total seal of eye orbit assures the highest level of protection.
- Filters 99% of U.V. radiation.
- Meets military MIL-PRF-31013 clause 3.5.1.1 for high velocity impact protection and exceeds ANSI Z87+.



Item#	Description
CRWCL010	Checklite®, clear uncoated lens, clear frame
CRWCL110	Checklite®, clear lens, clear frame
CRWCL110AF	Checklite®, clear anti-fog lens, clear frame
CRWCL112	Checklite®, gray lens, smoke frame
CRWCL113	Checklite®, light blue lens, frost blue frame
CRWCL114	Checklite®, amber lens, translucent yellow frame
CRWCL117	Checklite®, silver mirror lens, smoke frame
CRWCL118	Checklite®, blue mirror lens, smoke frame
CRWCL119	Checklite®, I/O clear mirror anti-fog lens, clear frame

FORCEFLEX® – Flexible frame adjusts to fit the wearer's face

Features

- Dual color axis design.
- Sleek dual lens design.
- Bayonet temple design.
- Duramass® scratch-resistant coating.
- Meets military MIL-PRF-31013 clause 3.5.1.1 for high velocity impact protection and exceeds ANSI Z87+.



Item#	Description
CRWFF120	ForceFlex®, clear lens, opaque black frame
CRWFF122	ForceFlex®, gray lens, opaque black frame
CRWFF124	ForceFlex®, amber lens, opaque black frame
CRWFF128B	ForceFlex®, blue diamond mirror lens, opaque black frame
CRWFF132	ForceFlex®, gray lens, translucent orange frame
CRWFF137	ForceFlex®, silver mirror lens, translucent orange frame
CRWFF210	ForceFlex® 2, clear lens, black frame, black rubber
CRWFF212	ForceFlex® 2, gray lens, black frame, black rubber
CRWFF220	ForceFlex® 2, clear lens, translucent brown frame, white rubber
CRWFF222	ForceFlex® 2, gray lens, translucent brown frame, white rubber
CRWFF232	ForceFlex® 2, gray lens, translucent yellow frame, black rubber
CRWFF214	ForceFlex® 2, amber lens, black frame, white rubber

Protection, Eye & Face - Safety Glasses

KLONDIKE® – Adjustable temples with 11 degree base curve lens

Features

- Strong, lightweight polycarbonate lens - 11 degree base curve.
- Adjustable temples.
- Gel nose piece.
- Filters 99.9% of U.V. Radiation.
- Meets or Exceeds ANSI Z87+.



Item#	Description
CRWKD110	Klondike®, clear lens, black matte frame
CRWKD110AF	Klondike®, clear anti-fog lens, black matte frame
CRWKD11B	Klondike®, brown lens, black matte frame
CRWKD112	Klondike®, gray lens, black matte frame
CRWKD112AF	Klondike®, gray anti-fog lens, black matte frame
CRWKD114	Klondike®, amber lens, black matte frame
CRWKD113	Klondike®, light blue lens, black matte frame
CRWKD117	Klondike®, silver mirror lens, black matte frame
CRWKD119	Klondike®, I/O clear mirror lens, black matte frame
CRWKD119AF	Klondike®, I/O clear mirror anti-fog lens, black matte frame
CRWKD120	Klondike®, clear lens, blue matte frame

KLONDIKE® PLUS – Why sacrifice style

Features

- 5-Position ratchet temples.
- Gel nose piece for long wearing comfort.
- Duramass® scratch-resistant coating.
- Strong, lightweight polycarbonate lens with 11 degree base curve.
- Filters 99.9% of U.V. radiation.
- Meets or Exceeds ANSI Z87+.
- Prescription eyewear insert available.



Item#	Description
CRWKD310	Klondike® Plus, clear lens, black matte frame
CRWKD312	Klondike® Plus, gray lens, black matte frame
CRWKD313	Klondike® Plus, light blue lens, black matte frame
CRWKD314	Klondike® Plus, amber lens, black matte frame
CRWKD319	Klondike® Plus, I/O clear mirror lens, black matte frame
CRWKD310AF	Klondike® Plus, clear anti-fog lens, black matte frame
CRWKD312AF	Klondike® Plus, gray anti-fog lens, black matte frame
CRWKD319AF	Klondike® Plus, I/O clear mirror anti-fog lens, black matte frame
CRWKDRX	Klondike® Plus RX insert is designed to fit any Klondike Plus protective eyewear style, clear lens, metal frame

MCR Safety has more than thirty years of experience as a leader in the field of personal protective equipment (PPE). MCR Safety's combined standard-setting products and industry-defining levels of service are backed by an unwavering commitment to excellence.

LAW® Over The Glass

Features

- Dielectric design.
- Excellent orbital seal.
- Higher level of protection from side impacts.
- Thermal plastic rubber temple inserts.
- Filters 99% of U.V. radiation.
- Meets or Exceeds ANSI Z87+.



Shown with glasses

Item#	Description
CRWOG110AF	Law® Over The Glass, clear anti-fog lens, steel color frame
CRWOG112AF	Law® Over The Glass, clear anti-fog lens, steel color frame

BLACKJACK® ELITE (small size)– Dual focus lens with great orbital seal

Features

- Treated with our exclusive Duramass® scratch resistant coating.
- Meets or Exceeds ANSI Z87+.
- Single wraparound lens design.
- Resilient spring hinge temples.
- Temple sleeve designed for breakaway cord.
- Slim and lightweight design.



Item#	Description
CRWS2210	Blackjack® Elite, clear lens, metal temple
CRWS2210AF	Blackjack® Elite, clear anti-fog lens, metal temple
CRWS2212	Blackjack® Elite, gray lens, metal temple
CRWS2219	Blackjack® Elite, I/O clear mirror lens, metal temple

RUBICON®– Curved frameless design

Features

- Curved lens offering 180 degrees viewing area.
- Close orbital seal.
- Resilient spring hinge temples.
- Strong, lightweight polycarbonate lens.
- Duramass® scratch-resistant coating.
- Exclusive Duramass® AF4 anti-fog coating.
- Meets or Exceeds ANSI Z87+ standard.
- Satin carrying case and Breakaway cord.
- Soft, secure gel nose piece.
- Non-slip gel temple.



Item#	Description
CRWT4110AF	Rubicon®, clear anti-fog lens, metal temple
CRWT4112AF	Rubicon®, gray anti-fog lens, metal temple
CRWT4113AF	Rubicon®, light blue anti-fog lens, metal temple
CRWT411G	Rubicon®, emerald green lens, metal temple
CRWT411R	Rubicon®, fire mirror lens, metal temple

EXPERIENCE THE DIFFERENCE

Protection, Eye & Face - Safety Glasses

RADIANS RAD-ATAC™ – Soft, non-slip rubber tipped temple



- Wraparound single lens / Integrated nosepiece.
- Lightweight, popular style / Blocks 99.9% of harmful UV rays.
- Meets all ANSI Z87.1 + standards.

Item#	Lens Color
RADAT1-10	Clear
RADAT1-11	Clear Anti-Fog
RADAT1-20	Smoke
RADAT1-21	Smoke Anti-Fog
RADAT1-90	Indoor/Outdoor
RADAT1-40	Amber
RADAT1-B	Light Blue
RADAT1-B11	Light Blue Anti-Fog
RADAT1-60	Silver Mirror
RADAT1-70	Blue Mirror
RADAT1-W2	Low IR

RADIANS RAD-SEQUEL™ – Lightweight, provides a comfortable fit



- Rubber tipped temples provide a secure fit.
- Soft, rubber nosepiece provides all day comfort.
- Polycarbonate lens provides impact resistance.

Item#	Lens Color
RADRS1-10	Clear
RADRS1-11	Clear Anti-Fog
RADRS1-20	Smoke
RADRS1-21	Smoke Anti-Fog
RADRS1-90	Indoor/Outdoor
RADRS1-60	Silver Mirror
RADRS1-70	Blue Mirror
RADRS1-B	Light Blue

RADIANS CUATRO™ 4-IN-1 FOAM LINED SAFETY EYEWEAR™ – Closed cell foam insert protects against airborne dust and debris



- Removable head strap provides an adjustable goggle-like fit.
- Eyewear temples easily snap-in.

RADIANS MIRAGE™ – Sleek design allows for a perfect fit for both men and women



- Optically correct and distortion free lenses.
- Economical dual wraparound 9.75 base lens provides near perfect orbital seal.
- Weighs less than 1 ounce.

Item#	Lens Color
RADMR0110ID	Clear
RADMR0111ID	Clear Anti-Fog
RADMR0120ID	Smoke
RADMR0121ID	Smoke Anti-Fog
RADMR0190ID	Indoor/Outdoor
RADMR0191ID	Indoor/Outdoor Anti-fog
RADMR0140ID	Amber
RADMR0160ID	Silver Mirror
RADMR01B0ID	Light Blue Lens
RADMR01R0ID	Rainbow Mirror

RADIANS MIRAGE™ FOAM – Foam lined safety eyewear designed to block debris, airborne particles and eye irritants.



- Closed cell foam construction for extra protection from debris.
- Full wraparound frame allows for unobstructed peripheral vision.
- Foam lined pockets/vents provide extra fog control.
- Polycarbonate lens provides impact protection.
- Mirage Foam Small also available - 10% smaller frame to fit a wider range of individuals.

Item#	Lens Color
RADMRF111ID	Clear Anti-Fog
RADMRF121ID	Smoke Anti-Fog
RADMRF191ID	Indoor/Outdoor Anti-Fog

- Anti-Fog polycarbonate lens provides impact resistance and fog control.
- Rubber nosepiece for all day comfort.
- Meets ANSI Z87.1+ standards / Provides 99.9% UV protection.

Item#	Lens Color
RADCT1-11	Clear Anti-Fog
RADCT1-21	Smoke Anti-Fog
RADCT1-61	Silver Mirror Anti-Fog
RADCT1-91	Indoor/Outdoor Anti-Fog

Protection, Eye & Face - Magnifier Safety Glasses

BEARKAT® MAGNIFIER

Features

- Available in various diopters.
- Single wraparound lens design.
- Flexible temple design.
- Polycarbonate lens.
- Non-slip rubber head grips.
- Filters 99% of U.V. radiation.
- Meets or Exceeds ANSI Z87+ safety standards.
- Duramass® anti-fog coating.



Item#	Description
CRWBKH10	BearKat®, 1.0 diopter clear lens, clear frame
CRWBKH10G	BearKat®, 1.0 diopter gray lens, smoke frame
CRWBKH15	BearKat®, 1.5 diopter clear lens, clear frame
CRWBKH15G	BearKat®, 1.5 diopter gray lens, smoke frame
CRWBKH20	BearKat®, 2.0 diopter clear lens, clear frame
CRWBKH20G	BearKat®, 2.0 diopter gray lens, smoke frame
CRWBKH25	BearKat®, 2.5 diopter clear lens, clear frame
CRWBKH25G	BearKat®, 2.5 diopter gray lens, smoke frame

KLONDIKE® MAGNIFIER

Features

- Strong, lightweight polycarbonate lens with 11 degree base curve.
- Dual bi-focal magnifier lenses.
- 5-Position ratchet spatula temples.
- Filters 99.9% of U.V. radiation.
- Meets or Exceeds ANSI Z87+ safety standards.
- Duramass® anti-fog coating.



Item#	Description
CRWK3H10	Klondike®, 1.0 diopter clear lens, black frame
CRWK3H10A	Klondike®, 1.0 diopter, amber lens, black frame
CRWK3H10G	Klondike®, 1.0 diopter, gray lens, black frame
CRWK3H15	Klondike®, 1.5 diopter clear lens, black frame
CRWK3H15A	Klondike®, 1.5 diopter, amber lens, black frame
CRWK3H15G	Klondike®, 1.5 diopter, gray lens, black frame
CRWK3H20	Klondike®, 2.0 diopter clear lens, black frame
CRWK3H20A	Klondike®, 2.0 diopter, amber lens, black frame
CRWK3H20G	Klondike®, 2.0 diopter, gray lens, black frame
CRWK3H25	Klondike®, 2.5 diopter clear lens, black frame
CRWK3H25A	Klondike®, 2.5 diopter, amber lens, black frame
CRWK3H25G	Klondike®, 2.5 diopter, gray lens, black frame

Looking for or considering a vending solution? With Abatix Supply Advantage Program – A.S.A.P. vending solutions you could reduce supply costs and improve productivity. Check out our web site to find out more about our A.S.A.P. vending solutions.



RADIANS CHEATERS™ READING SAFETY GLASSES – Combines protective safety glasses with reading glasses



- 5-Position lens angle adjustment provides a customized fit.
- Cushioned, non-slip rubber temple pads for superior comfort.
- Magnification diopter is molded into the polycarbonate lens.
- Lightweight nylon frame.
- High tech vented rubber nosepiece.
- Exceeds new ANSI Z87.1+ standards and blocks 99.9% UV rays.
- FREE Protective Sleeve included.

Item#	Strength *	Lens Color
RADCH1-110	1.0	Clear
RADCH1-115	1.5	Clear
RADCH1-120	2.0	Clear
RADCH1-125	2.5	Clear
RADCH1-130	3.0	Clear
RADCH1-215	1.5	Smoke
RADCH1-220	2.0	Smoke
RADCH1-225	2.5	Smoke
RADCH1-915	1.5	Indoor/Outdoor
RADCH1-920	2.0	Indoor/Outdoor
RADCH1-925	2.5	Indoor/Outdoor

RADIANS RAD-SEQUEL RSX™ (BI-FOCAL) – Magnification diopter is molded into lens



- Rubber tipped temples provide a secure fit.
- Soft, rubber nosepiece provides all day comfort.
- Lightweight design provides a comfortable fit.
- Polycarbonate lens provides impact resistance.

Item#	Strength *	Lens Color
RADRSB-110	1.0	Clear
RADRSB-115	1.5	Clear
RADRSB-120	2.0	Clear
RADRSB-125	2.5	Clear
RADRSB-130	3.0	Clear
RADRSB-415	1.5	Coffee
RADRSB-425	2.5	Coffee
RADRSB-430	3.0	Coffee

*Strength		
1.0+ - Weakest	2.0+ - Mild	3.0+ - Strongest
1.5+ - Weak	2.5+ - Strong	

Protection, Fall - Harness

DELTA™ HARNESSES

Advanced – Delta™ incorporates a spring-loaded, stand-up dorsal D-ring to help you make fast, easy and safe connections. Our exclusive i-Safe™ system gives you an efficient, digital way of recording and storing information on inspections. Delta™ also proves its workhorse standing with a 420-lb. carrying capacity.

Convenient – Our patented triangular design gives the Delta™ harness a shape of its own. The harness falls into place, allowing you to don it quickly and easily. Revolver™ torso adjusters make adjustments fast and secure, and Tech-Lite™ aluminum alloy buckles reduce both the weight you carry and the energy required to do your job during the course of a day.

Comfortable – Because Delta™ holds a basic shape, shoulder straps don't rub your neck raw. Made with soft, breathable materials, the Delta™ comfort hip pad ergonomically supports your back and hips while bearing heavy loads.

DELTA™ VEST STYLE HARNESS with Back D-Ring & Tongue Buckle Legs and with Back & Side D-Rings.

Features

- Delta™ lanyard keepers hold your unused snap hooks.
- Revolver™ Vertical Torso Adjuster: Simple and fast adjustment.
- Repel™ Webbing: Water repellent.
- Delta™ Comfort Hip Pad: Improved ergonomic fit and feel!
- Stand-Up Dorsal D-ring: Patented spring-loaded design.
- No tangle design.
- Built-in impact indicators.
- 420-lb. capacity.
- Velcro® cover protects harness labels and holds DBI-SALA's i-Safe identification tag.

Item# **DBI1102000** (Back D-Ring & Tongue Buckle Legs)

(Universal Size)

Item# **DBI1102008** (Back & Side D-Rings & Tongue Buckle Legs)

(Universal Size)



EXOFIT™ CONSTRUCTION STYLE HARNESS



ExoFit™ Construction Vest-Style Harnesses are made for general construction work. These harnesses have excellent tool-carrying capability, a sewn-in hip pad and removable body belt.

Product Details: Construction Vest-Style Harness with back D-ring, sewn-in back pad and belt with side D-rings and quick connect buckles. 420 lb. capacity, ultra-soft edging, cushioned shoulder, leg and hip pads, quick connect leg buckles, breathable back lining, easy grip tabs on web for easy adjustments. Anti-tear ballistic nylon web for abrasion resistance, reflective piping on harness.

Item# **DBI1108502** (Large)

DELTA™ CONSTRUCTION STYLE HARNESS with Back & Side D-Rings & Tongue Buckle Legs.



Features

- Delta™ lanyard keepers hold your unused snap hooks.
- Revolver™ Vertical Torso Adjuster: Simple and fast adjustment.
- Repel™ Webbing: Water repellent.
- Delta™ Comfort Hip Pad: Improved ergonomic fit and feel!
- Stand-Up Dorsal D-ring: Patented spring-loaded design.
- No tangle design.
- Built-in impact indicators.
- 420-lb. capacity.
- Velcro® cover protects harness labels and holds DBI-SALA's i-Safe identification tag.

Item# **DBI1101654** (Medium)

Item# **DBI1101656** (X-Large)



EXOFIT™ TOWER CLIMBING HARNESS



The ExoFit™ XP Tower Climbing Harnesses feature a removable seat sling for even more comfort for those who wear them all day long.

Product Details: Tower Climbing Harness, Vest style, front and back D-ring, belt with back pad and side D-rings, removable seat sling with positioning D-rings, quick connect buckles. 420 lb. capacity, cushioned shoulder, leg and hip straps, stand up back D-ring, breathable mesh lining, reflective piping.

Item# **DBI1110301** (Medium)

PRO™ HARNESS

Compliance has never been so easy or economical!



Introducing the all new, fully functional Protecta PRO™ harness. With designs that incorporate improved fit, updated colors, and durable yet lightweight construction, Protecta PRO™ harnesses provide greater comfort and added safety — which translates to reduced worker fatigue and increased productivity. Go with the gear with exceptional performance and value. Go with Protecta PRO™.

Features

- 420 Lb. (190kg) capacity.
- Improved fit and performance.
- Built-in impact indicator.
- Lightweight hardware.
- Label covers.

Item# **PRT1191209** (Medium/Large)



Protection, Fall - Harness

5 POINT FULL BODY HARNESS

Features

- Dorsal D-ring.
- Tongue buckle leg straps, pass-thru buckle chest and torso adjusters.
- Supple back plaque.
- Universal sizing.
- 1.75" Wide polyester web – blue top, black bottom.
- Minimum tensile strength >5,000 lbs.
- Zinc plated stamped steel.
- Meets or exceeds OSHA 1926 and ANSI Z359 performance criteria.

Item# **PRTAB17550** (Universal Size)



5 POINT POSITIONING FULL BODY HARNESS

Features

- Dorsal D-ring and side D-rings.
- Tongue buckle leg straps, pass-thru buckle chest and torso adjusters.
- Supple back plaque.
- Universal sizing.
- 1.75" Wide polyester web – blue top, black bottom.
- Minimum tensile strength >5,000 lbs.
- Zinc plated stamped steel.
- Meets or exceeds OSHA 1926 and ANSI Z359 performance criteria.

Item# **PRTAB17560** (Universal Size)



TITAN™ NON-STRETCH HARNESS
Constructed of Lightweight Polyester Webbing



Lightweight, durable webbing for all day comfort and dependability.



Features

- Fully adjustable designs.
- Rated to 400-lbs. (181.4kg) capacity.
- Sliding back D-ring.
- Two (2) pull-free lanyard rings.
- Trilingual labeling and instructions.
- Mating shoulder and chest leg strap buckles, tongue leg straps.

Item# **MLLT4500/UAK** (Universal)



MILLER REVOLUTION™ HARNESS
With DualTech™ Webbing



Introducing a totally-new concept in full-body harness design. The Miller Revolution Harness reinvents harness safety and functionality with features developed to meet key, user-identified needs. While exceeding worker expectations in comfort, fit, ease-of-use, style, durability, compliance, flexibility and convenience, the Miller Revolution Harness provides over Eleven key product features from seven new, unique components.



DualTech™ Webbing

Patent-pending DualTech webbing offers a soft, textured inside and a durable, chemical-resistant polyester outer material. Tested to 7,000 lbs. (31kN) minimum tensile strength (40 percent stronger than ANSI requirements) for greater safety and longer service life.



Features

RATED TO 400 lbs. (181.4kg) CAPACITY

All of Miller's premium harnesses are rated to 400 lbs. (181.4kg) capacity.



Web Finales – Clip-on design safely organizes webbing after proper adjustment.



PivotLink™ Connection – Unique rotary design provides greater comfort in bending/mobility.



ErgoArmor™ Back Shield – Semi-flexible back shield minimizes impact from sharp/heavy snap hooks and self-retracting lifelines.



DualTech™ Webbing – Donning made easy with two-sided, contrasting color webbing and textures.



Cam Buckle – Easy, one-hand adjustment/release allows simultaneous adjustment of shoulder straps.



Self-Contained Label Pack – Integrated pack encapsulates labels minimizing damage and loss.



Integrated Accessory System – Modular attachment design provides connection points for belts/tools/accessories.

Item# **MLLRDT-QC/UBK** (Universal)

EXPERIENCE THE DIFFERENCE

Protection, Fall - Lanyard



NANO-LOK™ SELF RETRACTING LIFELINES MAINTAIN SAFE FALL DISTANCES FOR IMPROVED WORKER SAFETY

COMPACT

Nano-Lok™ is ergonomically designed for ease-of-use and is ideal for direct connection to most harnesses. At only 1.6 lbs., it's virtually unnoticeable on your back, stays out of the way and can be easily used as a lanyard replacement.

VERSATILE

Whether your application requires single or twin leg configurations, mounting to an overhead anchor or for connection directly to a harness, there are more than 30 models to choose from to suit almost any application.

SAFE

Nano-Lok™ locks quickly—stopping a fall within inches—providing more protection at low heights. In addition, tension is always kept on the lifeline, which reduces dragging, snagging and trip falls. Both features are key safety improvements.

SINGLE LEG



Features

- Single Leg Anchorage Connector
 - Attaches directly to back of most harnesses—no separate carabiner required.
 - Installs to web, leaving dorsal D-ring open for other equipment or rescue.
 - Design provides snug fit to worker's back.
- Swiveling anchorage loop limits lifeline twisting for smoother operation.
- High-strength housing provides max. durability.
- Automatic Quick-Activating Arrestor
 - Stops falling worker within inches—reduces fall distances and average arresting forces to 900 lbs. or less.
 - Replaces lanyard and improves safety.
- At just 1.6 lbs., this SRL is the lightest, most compact unit on the market in its class.
- Wide variety of configurations provides complete jobsite versatility and flexibility.
- Integrated shock absorber provides visual indication of a fall.
- 6-Ft. retractable lifeline provides continuous fall protection without restrictions—keeps lifeline out of worker's way, reducing dragging, snagging and trip falls.

- i-Safe™ equipped helps track equipment and manage safety inspection programs.
- 3,600 Lb. gate reduces chances of accidental disengagement (roll-out) for added safety.
- 420 Lb. weight capacity – Higher capacity for operator and tools.
- Meets or exceeds industry standards: U.S. Models: OSHA 1926.502, 1910.66; ANSI Z359-2007 & A10.32 Canada Models: CSA Z259.2.2-98



STEP ONE:
Open connector by pushing down on the two locking buttons and sliding pin out.

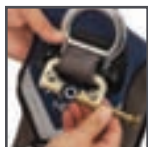

STEP TWO:
Slide connector through loosened web straps below back D-ring, then pull straps tight.



STEP THREE:
Slide swivel eye on SRL over the connector pin and push-in until it locks.

TWIN LEG



Features

- Twin Leg Anchorage Connector
 - Attach two SRLs directly to back of most harnesses.
 - Installs to web, leaves dorsal D-ring open for other equipment or rescue.
 - Design provides snug fit to worker's back.
 - Interchangeable SRLs allow for added versatility and replacement options.
- 100% Tie-off Configuration
 - Provides continuous fall protection and added mobility when moving from one location to another.
 - Replaces twin-leg lanyard and improves safety.

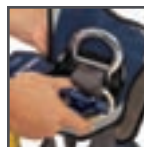

STEP ONE:
Open connector by pushing up plastic insert and carabiner gate inward. Insert nose of carabiner through swivel eye on SRL and rotate to the other side.



STEP TWO:
Slide nose end of carabiner behind loosened web straps below back D-ring and install second SRL.



STEP THREE:
Close connector carabiner & rotate the plastic insert down to secure making sure the web straps pass through the slot on the insert.

Protection, Fall - Lanyard



NANO-LOK™ LIFELINE HOOK AND ANCHOR OPTIONS

Item #	LIFELINE HOOK TYPE						ANCHORAGE TYPE						Lbs.			
	STEEL SNAP HOOK	STEEL REBAR HOOK	ALUMINUM REBAR HOOK	STEEL SWIVELING SNAP HOOK	ALUMINUM CARABINER (CAPTIVE EYE)	ALUMINUM SNAP HOOK	STEEL SNAP HOOK	STEEL REBAR HOOK	ALUMINUM REBAR HOOK	3100089 CAB MOUNT	3100088 SINGLE LEG CONNECTOR	3100087 TWIN LEG CONNECTOR		3100107 TWIN LEG CONNECTOR—FIXED	2000112 STEEL CARABINER	2000025 ALUMINUM CARABINER
DBI3101240	1									1						2.38
DBI3101239				1						1						2.67
DBI3101228	1										1					2.35
DBI3101253				1							1					2.64
DBI3101229		1									1					3.32
DBI3101225					1						1					1.97
DBI3101226						1					1					2.26
DBI3101227			1								1					2.92
DBI3101279	2											1				4.43
DBI3101278				2								1				5.02
DBI3101280		2										1				6.37
DBI3101275					2							1				3.69
DBI3101276						2						1				4.26
DBI3101277			2									1				5.57
DBI3101287	2												1			4.32
DBI3101274				2									1			4.90
DBI3101288		2											1			6.26
DBI3101271					2								1			3.57
DBI3101272						2							1			4.14
DBI3101273			2										1			5.46
DBI3101215	1													1		2.51
DBI3101216				1										1		2.80
DBI3101217		1												1		3.48
DBI3101218	1						1									2.61
DBI3101219		1					1									3.58
DBI3101241				1				1								3.88
DBI3101235					1										1	1.87
DBI3101214						1									1	2.16
DBI3101236			1												1	2.81
DBI3101237					1				1							2.81
DBI3101238						1			1							3.10
DBI3101252	1															1.95
DBI3101251				1												2.25
DBI3101250		1														2.92
DBI3101211					1											1.58
DBI3101210						1										1.87
DBI3101254			1													2.53
DBI3100089										1						.42
DBI3100088											1					.39
DBI3100087												1				.52
DBI3100107													1			.41

Protection, Fall - Lanyard

FIRST™ 6' LANYARD

Features

- Web: 1.75" polyester.
- Minimum tensile strength >5,000 lbs.
- Hooks: AJ523A - Zinc plated stamped steel
AJ595A - Forged steel.
- Net Weight, 3.74 lbs.
- Meets or exceeds OSHA 1926 & ANSI Z359 performance criteria.

Item# **PRTAE57620**



PROTECTA PRO™ CHAIN REBAR POSITIONING LANYARD

All PRO™ Positioning lanyards feature 3,600 lb. (16kN) gated hooks and are used to maintain a working position. These devices do not incorporate shock absorbers and can only be used without a fall arrest system if the fall possibility is 2 ft. (0.6m) or less.

Features

- Swivelling chain rebar assembly with snap hooks.
- Flat steel rebar hook at center x 24" (61cm).

Item# **PRT1350150**

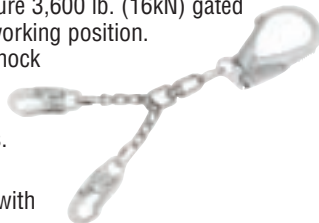

PROTECTA PRO™ TIE-BACK SHOCK ABSORBING LANYARD

Features

- 100% Tie-off shock absorbing lanyard.
- Double-leg with floating D-rings for tie-back.
- Snap hooks x 6 ft. (1.8m).

Item# **PRT1342200**

Item# **PRT1342201**

(With 2 Large Rebar Hooks)



PROTECTA PRO-STOP™ SHOCK ABSORBING LANYARD

PRO-Stop™ lanyards feature polyester tubular web, as opposed to a traditional shock pack, 3,600 lb. (16kN) gated hooks and an energy absorbing design that limits the average fall arresting forces to 900 lbs. (4kN) for added safety.

Features

- Single-leg with self locking snap hooks at each end x 6 ft. (1.8m).

Item# **PRT1340220**



PROTECTA PRO™ STRETCH SHOCK ABSORBING LANYARD

PRO™ Stretch lanyards feature polyester tubular web that expands to 6 ft. (1.8m) and contracts to 4.5 ft. (1.4m), 3,600 lb. gated hooks and an energy absorbing design that limits fall arrest forces to 900 lbs. or less.

Features

- 100% Tie-off shock absorbing lanyard.
- Double-leg with snap hook.
- Flat steel rebar hooks at leg ends x 6 ft. (1.8m).

Item# **PRT1340161**



SHOCKWAVE2™ SHOCK ABSORBING LANYARD

Features

- Expands to 6 ft., contracts to 4½ ft. in reaction to your movements.
- Reduces trip fall hazards, dragging and snagging for complete freedom of movement.
- Easy to use self locking snap hooks at both ends.
- Abrasion resistant tubular webbing for durability and longevity.
- Impact indicator allows user to visually inspect unit for a fall.
- 6 Ft. in length.
- Limits arresting forces to 900 lbs. or less.
- Meets or exceeds all applicable industry standards including OSHA, ANSI and the stringent ANSI Z359.

Item# **DBI1244306**

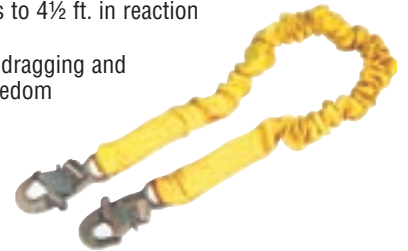

SHOCKWAVE2™ SHOCK ABSORBING LANYARD (Twin-Leg)

Features

- Expands to 6 ft., contracts to 4½ ft. in reaction to your movements.
- Reduces trip fall hazards, dragging and snagging for complete freedom of movement.
- Twin-leg 100% tie-off style helps you remain connected at all times.
- Easy to use self locking snap hooks at center and flat steel hooks (2½" opening) at the leg ends.
- Abrasion resistant tubular webbing for durability and longevity.
- Impact indicator allows user to visually inspect unit for a fall.
- 6 Ft. in length.
- Limits arresting forces to 900 lbs. or less.
- Meets or exceeds all applicable industry standards including OSHA, ANSI and the stringent ANSI Z359.

Item# **DBI1244412**



TITAN TIE-BACK LANYARDS WITH PACK-TYPE SHOCK ABSORBERS

Features

- Special webbing for greater abrasion resistance.
- Forged sliding D-ring for ease of use.
- Auto-locking carabiner for added safety.
- Locking snap hook for connecting to the harness back D-ring.
- Shock-absorber pack that keeps fall forces at or below 900 lbs./f (4kN).
- Standard length – 6-ft. (1.8m).

Item# **MLLT6121TB/6FTAF**





Protection, Fall - SRL

REBEL™ WEB SELF RETRACTING LIFELINES

The retractable technology deployed in the Rebel™ SRL's ensures falls are stopped within a few inches, making Rebel™ SRL's safer than traditional lanyards.

Lightweight, Compact and Durable

The Rebel™ SRL incorporates a rugged aluminum housing and stainless steel working components that can withstand rough use. The unique thin webbing enables a compact size.

Ergonomic for Greater Worker Comfort

With a smooth case and rounded corners, the Rebel™ SRL provides added comfort and ease-of use. It increases worker productivity and reduces worker fatigue for ultimate worker satisfaction.

Limits Fall Clearance and Forces for Safety

A unique speed sensing brake keeps forces to a minimum, and reduces clearance requirements. With a maximum arresting force of 900 lbs. (4kn), it supports a capacity of 310 lbs. (140kg).

REBEL™ 11' (3.3m) WEB SELF RETRACTING LIFELINES

Features

- Economically replace lanyards with the versatility and added safety of a 11 ft. (3.4m) self retracting lifeline.
- Retractable technology reduces fall clearance and trip hazards for complete safety.
- Rugged aluminum housing can withstand rough use.
- Unique super-strength thin webbing for total security and added length in a compact SRL.
- 2-year warranty on parts and workmanship, plus no annual re-certification is required.
- Meets all applicable industry standards including OSHA, ANSI Z359.1 and CSA.

Item# **PRTAD111A**



REBEL™ 20' (6.1m) WEB SELF RETRACTING LIFELINES

Features

- Economically replace lanyards with the versatility and added safety of a 20 ft. (6.1m) self retracting lifeline.
- Retractable technology reduces fall clearance and trip hazards for complete safety.
- Rugged aluminum housing can withstand rough use.
- Unique super-strength thin webbing for total security and added length in a compact SRL.
- 2-year warranty on parts and workmanship, plus no annual re-certification is required.
- Meets all applicable industry standards including OSHA, ANSI Z359.1 and CSA.

Item# **PRTAD120A**

Item# **PRTAD120AR** (Swivel Web SRL)



REBEL™ 33' (10m) SELF RETRACTING LIFELINES

These SRL's incorporate a lifeline that extends and retracts automatically, allowing unhindered movement around the work area. A brake activates in the event of a fall, stopping the worker within inches and limits arresting forces to OSHA and ANSI requirements. Rebel™ continues to set performance standards beyond compliance, while providing a substantial value compared to competitive models.

Features

- Self Retracting Lifeline with 5mm Galvanized Cable.
- Thermoplastic Housing and Carabiner.

Item# **PRT3590500**



TALON™ 100% TIE-OFF SELF RETRACTING LIFELINE (6')

Features

- Added mobility with two 6 ft. lifelines within one unit.
- 100% Tie-off capabilities for safe work at heights.
- Steel swiveling self locking snap hooks.
- Inertia activated for quick response time and reduced arresting forces.
- Compact, lightweight design.
- Durable nylon housing with quick connect handle, rugged and lightweight for attachment to harness.
- No service / recertification required, reduces cost of ownership.
- Extra-strong and long-lasting materials for extended product life.
- 1 in. diameter nylon web lifelines.

Materials:

- Web Lifeline: 1 in. wide nylon, 5,000 lb. tensile strength, 6 ft. length ea. line
- Housing: nylon type 6-6, blue
- Drum: reinforced nylon type 6-6
- Drum Flange: aluminum
- Drum Spring: stainless steel, type 301
- Ratchet Pawls: stainless steel, heat treated
- Ratchet Plate: alloy steel, heat treated
- Shaft: aluminum
- Snap Hook: alloy steel or aluminum, 5,000 lbs. min. tensile strength
- Quick Connect Handle: alloy steel, heat treated.

Standards – Complies with:

- OSHA 1910.66 , OSHA 1926.502
- ANSI Z359.1-1992
- CSA Z259.2.2 (type 1)
- CE compliant models available (per EN364:1993).

Capacity: 310 lbs.

Maximum Arresting Force: 900 lbs.

Item# **DBI3102006**



EXPERIENCE THE DIFFERENCE

Protection, Fall - Anchorage Point

SAFLOK™ CONCRETE WEDGE ANCHOR

Features

- Provides a safe, fall arrest rated 22kN anchor point for vertical concrete applications.
- Portable and reusable anchor can be removed and simply re-installed in a new location for added jobsite flexibility and lower overall cost of ownership.
- Quick-release button boosts productivity by providing immediate anchor removal for added worker satisfaction.
- Virtually eliminates the need for tools to remove a stuck anchor from the hole, giving the user instant mobility.
- Unique forged connection ring provides a compatible tie-off point for your personal fall arrest system for added safety.
- Load cable and chock release cables are shielded from damage caused by grinding against the concrete lip of the hole for a longer service life.
- Exclusive pivoting easy-grip handle provides cable kink protection for added safety and longer service life.
- Constructed of stainless steel, aluminum and other non-corrosive materials for a longer service life.
- Designed for use in cured concrete with a compression strength of at least 21MPa.
- Complies with EN795 Class B.

Item# **DBI2100085**



CONCRETE D-RING ANCHOR

Features

- A simple, versatile and safe concrete anchor solution – for use in temporary or even permanent applications.
- Re-usable D-ring assembly, just install a new bolt and it's ready for use again.
- Rugged design for harsh environments with no moving or fragile parts to foul-up.
- Safe "hook-up" indicator notifies the user the anchor has been installed properly.
- For flexibility, install into 11/16", 18mm or 3/4" holes – only standard drill bits needed.
- 5,000 Lb. rated, OSHA compatible connection point swivels 360 degrees for safety and usability.
- Meets or exceeds all applicable industry standards including OSHA, ANSI and ASTM E488 Standard Test Methods for Strength of Anchors.

Item# **DBI2104560**

Item# **DBI2104561** (D-ring Assembly with 5 Bolts)

Item# **DBI2104562** (D-ring Assembly with 11 Bolts)

Item# **DBI2104566** (Bolt Kit, 10 Pack)



ANCHOR, CONCRETE PARAPET (Portable)

Features

- Does not penetrate the working surface, reducing the possibility of damage.
- Adjustable, 1" to 14.5" wide.
- Fall arrest rated for one user.
- No tools required for installation.
- 5,000 Lb. rated.
- The anchor can be used with a shock absorbing lanyard or self retracting lifeline.

Item# **DBI8523178**



CONCRETE ANCHOR STRAP

Features

- Disposable anchor strap is designed to provide a temporary anchorage on concrete forms.
- Loop on end of anchor slips over rebar, concrete is then poured on top of loop and wear pad.
- Once concrete sets, a safe 5,000 lb. fall arrest anchorage point exists.
- When no longer needed, simply cut strap and discard.
- Durable 1-3/4" polyester webbing construction with full length outer wear pad for ultimate abrasion resistance.
- Forged alloy steel D-ring provides compatible connection point for your lanyard or self retracting lifeline.
- Meets or exceeds all applicable industry standards including OSHA, ANSI and the stringent ANSI Z359.

Item# **DBI2100050**



ROOF TOP ANCHOR FOR METAL & WOOD SHEATHING

Complete Jobsite Flexibility

Specialized Load Distributing Design

Fast, Simple and Safe Tie-off Point

Single or Multi-Person Use

Features

- Compatible with 24 gauge metal corrugated roofs or thicker.
- Fits metal corrugated roof ribs 10" to 20" apart in 1" increments.
- Concrete mounting option available.
- 5/8" CDX plywood or thicker mounting option available.
- Unique "tip-over" design better distributes the forces generated during a fall preserving the structural integrity of the roof.
- OSHA compatible anchor ring at top of stanchion.
- Meets or exceeds all applicable industry standards including OSHA and ANSI Z359.1.

Item# **DBI2100075**



ROOF TOP ANCHOR FOR MEMBRANE & BUILT-UP TYPE ROOFS

Features

- Compatible with single ply membrane and built-up type roof structures.
- Standard product fastens through the membrane, insulation and into the metal sheathing, wood sheathing or concrete.
- Can accommodate up to 5.5" of combined roof material, insulation and decking with the standard product fastening methods.
- Zinc plated base plate helps facilitate a true waterproof seal for membrane type roofs.
- Unique "tip-over" design better distributes the forces generated during a fall preserving the structural integrity of the roof.
- OSHA compatible anchor ring at top of post for added safety.
- Meets or exceeds all applicable industry standards including OSHA and ANSI Z359.1.

Item# **DBI2100076**

Item# **DBI2100077** (With 10.5" Bolt Kit)



Protection, Fall - Anchorage Point

TIE-OFF ADAPTOR

Pass-Through Style – Versatile Anchorage Connector

Features

- Pass-through design makes attaching to anchorage quick and easy.
- 1-3/4" Polyester strength member (5,000 lb. min. tensile strength).
- 3" Wide polyester wear pad for added abrasion resistance and product longevity.
- 3 Ft. in length, other lengths available.
- Coated steel hardware for corrosion resistance and strength.
- Meets or exceeds all applicable industry standards including OSHA, ANSI and the stringent ANSI Z359.

Item# **DBI1003000**

Item# **DBI1002103** (adjustable tie-off adaptor)

Item# **DBI1003006** (6' in length)

Item# **DBI1002106** (6' adjustable tie-off adaptor)



D-RING WITH ANCHORAGE PLATE

Features

- Can be bolted or welded to structure.
- Two 1/2" diameter attachment holes.
- Stainless steel construction for durability.
- Plate size: 1/4" x 2" x 4-1/2".
- Meets or exceeds all applicable industry standards including OSHA, ANSI and the stringent ANSI Z359.

Item# **DBI2101630**



CABLE CHOKER (Tie-Off Adaptor)

Features

- Pass-through design makes attaching to anchorage quick and easy.
- 7x19-3/8" Stainless steel cable construction (5,000 lb. min. tensile strength) for added abrasion resistance and product longevity.
- 4 Ft. in length, other lengths available.
- D-ring at one end, O-ring at other, coated steel hardware for corrosion resistance and strength.
- Meets or exceeds all applicable industry standards including OSHA, ANSI and the stringent ANSI Z359.

Item# **DBI59005500**

Item# **DBI5900551** (6' in length)



SAFLOK™ CARABINER

Features

- Self-closing/Self-locking gate for increased safety and security.
- Steel construction for durability.
- User-friendly design for simple operation even while wearing gloves.
- Gate Face withstands a load of 3,600 lbs. (up from 220 lbs.)
- Side of Gate withstands a load of 3,600 lbs. (up from 350 lbs.)
- Minor Axis withstands 3,600 lbs.
- High strength construction with a minimum tensile strength of 5,000 pounds.
- Compatible with most connecting rings.
- Meets or exceeds all applicable industry standards including OSHA and the the new 2007 ANSI Z359 standard.

Item# **DBI2000112** (11/16" Gate Opening)

Item# **DBI2000113** (1-3/16" Gate Opening)

Item# **DBI2000114** (2-3/16" Gate Opening)



GLYDER2™ SLIDING BEAM ANCHOR

Features

- Provides complete horizontal mobility, tie-off overhead or at your feet (use with Force2™ shock absorbing lanyard when used at your feet).
- Anchor effortlessly slides across the beam on its wear pads, eliminating metal-to-metal contact.
- Integrated ratcheting adjustment system provides quick and easy installation and removal. NO MORE PINS AND CHAINS!
- Unique guarded locking mechanism protects the anchor from accidental disengagement.
- Dual beam grip adjustment prevents twisting and turning as it moves along the beam.
- Extremely lightweight at only 3.7 lbs. (1.66kg), with a user capacity of 420 lbs. (189kg) and a minimum breaking strength of 5,000 lbs. (22kn).
- Replaceable synthetic wear pads.
- Fits flange 3-1/2" to 14" wide and up to 1-1/4" thick.
- Meets or exceeds all applicable industry standards including OSHA, ANSI A10.32, Z359.1 and EN795.

Item# **DBI2104700**



TROLLEY ANCHORAGE CONNECTOR

Features

- Trolley for use with self retracting lifelines on horizontal beams.
- Attachable anywhere along beam including midpoint.
- Trolley Guards protect the wheels from damage and keep beam clear of debris.
- Fits 3" to 8" flange width thickness up to 11/16".
- Dual adjustment dials are fixed to trolley for precise alignment in 1/8" increments.
- Meets or exceeds all applicable industry standards including OSHA, ANSI and the stringent ANSI Z359.

Item# **DBI2103143**

Item# **DBI2103147** (Stainless Steel Components)

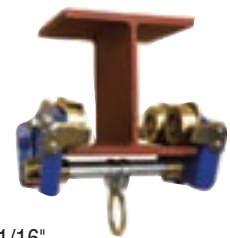

Abatix' online ordering system is simple to use. Once you are registered and have a customer code, you can create orders, customize shopping lists, and view ordering history, track shipments, view and print invoices and pay bills online. Head over to www.abatix.com and start shopping today.

EXPERIENCE THE DIFFERENCE

Protection, Fall - Vertical Systems

VERTICAL LIFELINE - 50'



Specifications

- Nylon rope.
- 5/8" Diameter.
- 50' Long.
- Max working load: 310 lb.
- Standards: OSHA, ANSI.
- Weight: 5.32 lbs.

Item# **PRTAC215A**



COBRA ROPE GRAB



Features

- Constructed of high impact resistant steel.
- 1.75 Lbs. total weight.
- Operates in automatic or manual mode.
- Accommodates 5/8" rope.
- Can be used on approved horizontal rope systems.
- Can be removed and reattached to rope at any point during traverse.
- Compliance with OSHA 1926 and ANSI Z359 Standards.
- Designed for use with nylon or polyester rope.

Item# **PRTAC202D**

LAD-SAF™ SLEEVE FOR 8mm AND 3/8" CABLE SYSTEMS Flexible Cable Ladder Safety System



With DBI-SALA's Lad-Saf™ Flexible Cable Ladder Safety Systems you are always assured of complete safety and security when climbing fixed ladders on poles, towers, tanks, etc. Every system is engineered to your specific requirements while meeting or exceeding OSHA and ANSI standards. The shock absorbing top bracket and tension indicating bottom bracket serve as the anchors for the steel cable which runs the length of the climbing area. Non-metallic cable guides reduce cable wear, permitting you to ascend or descend unhindered. The economical, easy to use systems are available for

straight or curved ladders and for connection to wood, concrete or steel structures.

Item# **DBI6116540**



Protection, Fall - Horizontal Systems

EZ-LINE™ RETRACTABLE HORIZONTAL LIFELINE SYSTEM

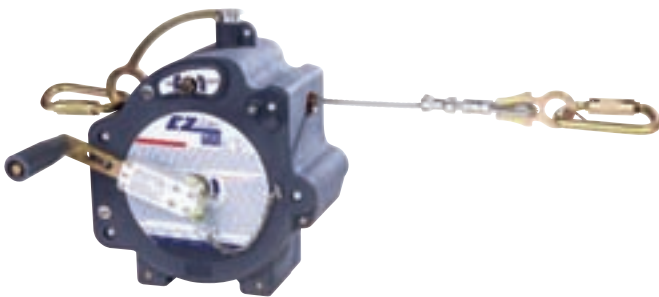

EZ-Line™ is the most user friendly and fastest horizontal lifeline system to install, remove and store on the market today! EZ-Line's innovative retractable design allows the user to quickly and efficiently set-up any length of system in only seconds and dismantle it just as quick. The entire 60-ft. EZ-Line system (40-ft. in Canada) is retracted into an easy to carry case which eliminates large and bulky coils of cable that are difficult to set up, relocate and store. Additionally, EZ-Line weighs only 25 lbs. (32 lbs. in Canada) which is 33% lighter than traditional systems providing ease-of-use and added worker satisfaction.

Install in four simple steps:

- 1) attach the lifeline with carabiner to an anchorage connector
- 2) depress the locking button allowing cable to pay out and walk to the next anchorage
- 3) attach the housing/case with carabiner to the anchorage connector
- 4) tension the lifeline with the built-in crank handle.

Features

- Retractable lifeline is simply pulled out for installation and retracted with the built in winch for dismantle.
- Customize your system length in any increment up to 60 ft. (40 ft. in Canada).
- Entire system stores in an easy to carry case – No more coils of unmanageable cable.
- Built in pre-tension and impact indicators take the guess work out of set-up and inspection.
- 33% Lighter than conventional system.
- Provides hands free horizontal mobility and continuous protection for 2 users.

Item# **DBI7605060**



Did you know Abatix offers training courses? Located in our Santa Fe Springs, CA, Phoenix, AZ and Jacksonville, FL branches, Abatix Learning Centers offer a variety of certification classes regulated by both governmental and industry related groups, such as OSHA, EPA, Licensing groups (IICRC, IAQA, Maritime, and Construction), as well as product demonstrations and general industry informational sessions. Check our web site for details.

Protection, Fall - Speciality

VERTICAL NET DEBRIS CONTAINMENT SYSTEM (48" x 100')



Features

- Vertical Net not only protects from falling debris but also protects workers near building edges by serving as a guardrail.
- 48" High x 100 ft. long with 55 EZ clips and 22 tie-down plates.
- Increases public safety by preventing falling debris.
- Eliminates the need for a separate mid-rail and toe-board.
- Easy to install, remove, relocate and store.
- Exceeds strength requirements of OSHA's 200-lb. lateral force test.
- Highly visible so you know it's in place even from the ground level.
- Also useful as temporary partitions for crowd control or demolition.
- System comes complete with everything needed, vertical netting, zip clips for easy and secure net installation and tie-down plates to replace toe-boards and firmly set the net into place.

Easy to Install:

Designed for use with traditional cable set-ups, the nets attach to the cable with supplied DBI-SALA Zip Clips. The bottom edge of the net is quickly secured using a power actuated tool to fire the nail into the tie-down plate. The system is complete with Zip Clips and tie-down plates. The nets are supplied in 100' lengths in your choice of 48" or 66" heights (42" or 60" installed).

Easy to Remove:

Relocate, handle and store. Removing and relocating the system is simple, saving you time and money. Simply remove the Zip Clips and pry the nails out of the tie-down plates with a hammer. The nets and hardware are reusable if properly removed and stored.

Meets all Regulatory Requirements:

The DBI-SALA Vertical Net Debris Containment System is made of performance-proven polyethylene mesh which is UV resistant and fire retardant. They also exceed OSHA's 200-lb. lateral strength requirements and the New York City Construction Code requirements.

Compare the Benefits:

The Vertical Net System is a complete system and: • Uses a tight mesh to contain large and small objects • Can act as a wind barrier, reducing the occurrence of wind blown objects • Acts as a visual safety barrier because of the net's bright orange color • Available as a complete system or replace only what is needed.

Item# **DBI4100300** (With Attachment Kit)
(55 EZ clips and 22 tie-down plates)

Item# **DBI4100200** (Without clips and plates)

SUSPENSION TRAUMA STRAP



Features

- Helps prevent the effects of suspension trauma after a fall.
- Allows worker who is suspended to stand up in their harness to relieve pressure.
- A safety accessory that can be attached to most harness brands/styles right in the field.
- Installation to your harness is fast and efficient – just choke off to strap and it's ready.
- Extremely compact and lightweight design stays out of the worker's way.
- Deployment and operation is fool-proof, simply unzip, and hook straps together.
- Continuous loop design allows for either 1- or 2-ft. suspension relief without pinching.
- Arc flash version available.

Item# **DBI9501403**

COMPLIANCE IN A CAN



Compliance-In-A-Can™ kits feature designs that incorporate improved fit, updated colors, and durable yet lightweight construction. Protecta® PRO™ gear provides greater comfort and added safety – which translates to reduced worker fatigue and increased productivity. Plus, each and every Protecta® PRO™ lanyard now features 3,600 lb. gated hooks meeting ANSI Z359.

Kit Includes

- Reusable roof anchor.
- 5 Point harness.
- Rope grab.
- 50' Lifeline.

Item# **PRT2199812**

Protection, Fall - Confined Space

SALALIFT® / SEALED SRL & TRIPOD COMBINATION



For utmost confidence, DBI-SALA's packaged rescue systems are a perfect rescue/retrieval safety solution. You can go onto the job knowing that your equipment is ready to go; totally compatible and built with DBI-SALA quality.

Features

- Complete rescue system including tripod, Salalift® winch and back-up or secondary sealed self retracting lifeline.

Tripod:

- 7 Ft. aluminum tripod is lightweight and portable, easily set up by one worker and can be transported from one location to another just as easy.
- Adjustable locking legs adjust quickly in increments of 2-3/4" for added versatility and are kept in position with locking push pins – adjusts from 5 ft. to 7 ft. height and will span a 5 ft. diameter hole.
- Complete with safety chain to prevent movement and safety shoes that incorporate a rubber sole for flat surfaces and spiked edges for slippery surfaces.
- Heat treated cast aluminum head incorporates a built-in pulley system to route lifeline of mechanical device directly over opening. Also equipped with drop forged steel eyebolts for use as anchorage point for secondary or back-up system, designed to allow the eyebolt to hand plumb regardless of surface configuration.

- Complete with quick-mount bracket for attachment of DBI-SALA mechanical device for ease of use.
- Additional (back-up) mechanical devices can be mounted to tripod with optional bracket/pulleys.
- Rated working load is 350 lbs. for work support and 310 lbs. for fall arrest, can withstand up to 5,000 lbs. of vertical pull.
- Durable corrosion resistant aluminum and heat treated cast aluminum construction.
- Underwriters Laboratories tested and classified.
- Meets or exceeds the strength requirements for anchorage's (5,000 lbs.), ANSI Z359.1, ANSI A10.14 and OSHA requirements.

Salalift® Winch:

- Salalift® winch is designed for raising, lowering, work support or personnel rescue.
- Triple braking system including two independent centrifugal brakes and one dead-man type brake for added security.
- Two-speed input (primary 6.6:2, secondary 3.3:1) for versatility and ease-of-use.
- Durable corrosion resistant construction featuring a heat treated cast aluminum housing with steel gears contained in a sealed oil bath.
- Overload clutch (load limiting input handle) reduces chance of injury to entangled worker.
- Winch features 60' of galvanized 1/4" steel cable, complete with carrying bag.
- Complete with unique quick-mount bracket making attachment to DBI-SALA support structures (tripod, davit arm, etc.) simple and easy.
- Underwriters Laboratories tested and classified.
- Meets or exceeds all applicable industry standards including OSHA 1910.28 and 1926.451, OSHA 1910.146 and ANSI Z117.1.

Sealed Self Retracting Lifeline:

- Sealed self retracting lifeline with stainless steel and cast aluminum housing for corrosion resistance.
- 50 Ft. 3/16" galvanized steel wire rope for durability (50, 85 and 130 ft. lengths in galvanized or stainless steel are available).
- Built in retrieval winch for raising/lowering load during emergencies with built-in shock absorbing capabilities (fall arrest capabilities in retrieval mode for added safety).
- Input crank handle incorporates brake which will prevent movement of the load if the operator accidentally released the handle during raising/lowering.
- Winch drive incorporates an overload device thus reducing the possibility of injury should the worker become entangled during retrieval.
- Environmentally sealed design for safety, even in harsh environments.
- Self adjusting disc brake for reliability.
- Reserve lifeline retention system for added safety.
- Self-locking swivel snap hook with impact indicator.
- Swiveling anchorage loop to prevent twisting of lifeline.
- Quick-mount bracket (model 3401065) enables user to attach to a DBI-SALA support structure with ease and carrying bag (model 9503515).
- Meets or exceeds all applicable industry standards including OSHA, ANSI and the stringent ANSI Z359.

Item# **DBI8304000**

Item# **DBI8304010** (Tripod, Sealed SRL and Salalift® II Winch)

Protection, Hand

MAX COW GRAIN LEATHER DRIVERS GLOVES



- Features
- Full leather gloves.
 - Cream color.
 - Straight thumb.
 - Brown cotton hem.
 - Sizes: XS, S, M, L, XL, XXL.
 - Elastic back.

Item# **MAXDVR**

MAX SPLIT SHOULDER GENERAL PURPOSE GLOVES



- Features
- Cow leather gloves.
 - 2-1/2" Rubberized safety cuff.
 - Double leather palm.
 - Cotton back.
 - Size: L.

Item# **MAXDLP**

MAX MAXFLEX WORK GLOVES



- Features
- 10 Gauge cotton.
 - Polyester shell.
 - Textured latex palm and fingertip dip for extra grip.
 - Sizes: M, L, XL.

Item# **MAXFLEX**

NORTHFLEX LIGHT TASK PLUS II™ – PU COATED DYNEEMA® GLOVES
A light and comfortable glove that provides excellent cut and abrasion resistance combined with the cool comfort of Dyneema®.



- Features and Benefits**
- Up to 15 times stronger than steel.
 - Polyurethane palm coating.
 - Glove conforms to shape of hand.
 - Back of glove is un-coated.
 - No natural rubber proteins.
 - Complies with USDA & FDA regulations, 21 CFR, for use in food processing.
 - White Dyneema® liner, coated with white PU.
 - ANSI cut level 1.
 - Sizes: 7 (S), 8 (M), 9 (L), 11 (XXL).

- Applications**
- This glove is ideally suited to applications involving the handling of sharp objects, such as sheet metal and glass.
 - Sheet metal handling, metal fabrication work, automotive and other assembly work.

Item# **NSPNFD15**

NORTH BUTYL™ – UNSUPPORTED GLOVES –The glove of choice for military, disaster preparedness and industrial users the world over.



- Features and Benefits**
- Highest permeation resistance to gas and water vapor for greater worker protection, especially when handling toxic substances.
 - Highly resistant to ketones (MEK, MIBK, acetone) and esters (tricresyl phosphate, amyl acetate, ethyl acetate).
 - Flexible and sensitive, even at lower temperatures.
 - Curved finger and hand design provides a better fit for greater worker comfort.
 - Available with "Grip-Saf" palm for enhanced grip.
 - Black, sanitized interior / Rough Grip-Saf/rolled bead Grip/Cuff.
 - Sizes: 7, 8, 9, 10, 11.

- Applications**
- Aircraft maintenance, automotive, chemical handling and processing, domestic preparedness, laboratory, Haz-Mat work, solvents (general).

Item# **NSPB161R** 11" Length, 16 mil Gauge.

Item# **NSPB324R** 14" Length, 32 mil Gauge.

NORTHFLEX RED™ FOAMED PVC PALM COATED GLOVES
Light and comfortable general purpose gloves that offer high abrasion resistance and exceptional grip.



- Features and Benefits**
- Advanced 15 gauge seamless nylon liners are stretchy and form fitting, with a snug knit-wrist, and provide minimal resistance to hand movement for exceptional wearer comfort.
 - Foamed PVC coatings, are soft and flexible enough to provide a degree of shock and vibration absorption, but are tough enough to offer abrasion resistance comparable to polyurethane.
 - In addition, foamed PVC has an open surface texture that clears liquids from surfaces and enables a very firm wet-grip.
 - The Red-X™ features an extended knuckle coating, for additional wearer protection.
 - Back of glove is un-coated, for ventilation and wearer comfort.
 - Launderable for added value and longer life.
 - Cuff over-stitching is color-coded by size to aid sorting after laundering.
 - Red nylon liner, palm coated with black foamed PVC.
 - Sizes: 6 (XS), 7 (S), 8 (M), 9 (L), 10 (XL), 11 (XXL).

- Applications**
- These gloves are well suited to applications where workers handle both wet and dry objects and need moderate protection from mechanical hazards, including automotive and other assembly work, manufacturing, maintenance and small parts handling.

Item# **NSPNF11**

EXPERIENCE THE DIFFERENCE

Protection, Hand

MULTI-TASK GLOVES

FORCEFLEX® ZOOMBANG® – Impact resistant gloves for excellent protection from shocks and jolts.

The Zoombang® polymer is soft and fluid-like to the touch. Upon impact, the Zoombang® stiffens and locks to a solid state providing maximum protection. After impact, Zoombang® returns to its soft, fluid-like state.

Features

- Zoombang® material in palm.
- TPR Protection Cage for back of hand protection.
- Terry cloth brow wipe on thumb.
- Clarino® synthetic leather base palm.
- Sure Grip finger tips.
- Hook & Loop wrist closure.
- Sizes: M, L, XL, XXL.



Applications – Common applications are construction, glass handling, metal fabricating, and applications requiring protection from excessive stress to the hands.

Item# **MEGZB100**

FORCEFLEX® – Flexibility with a wide range of palm options.

The ForceFlex® line of multi-task gloves provides the ultimate back of hand protection while providing full flexibility and range of motion.

Features

- Molded TPR protection cage on back of hand and knuckles.
- Sure Grip finger tips.
- Adjustable Hook & Loop wrist closure w/pull tab or slip or Neoprene cuff options.
- Synthetic, Clarino® leather, and Kevlar® reinforced palm options.
- Reflexite micro-prismatic retroreflective material on both sides of cuff on the HV100 & HV200.



MEGHV200

Applications – Common applications are construction, carpentry, material handling, hand/power tool use, light demolition, search and rescue, and assembly. Oil and gas industry.

Item# **MEGHV300** Dry grip style, full finger, hi-vis lime, mesh material, synthetic palm w/sure grip finger tips.
Sizes: M, L, XL, XXL.

Item# **MEGHV200** Insulated breathable, water and wind resistant with rough Kevlar® palm pads and snow guard cuff.
Sizes: M, L, XL, XXL, XXXL.

Item# **MEGHV100** Rough Kevlar® palm pads with TPR padding on back of hand and fingers. Sizes: M, L, XL, XXL, XXXL.

Item# **MEGY300** Clarino® synthetic palm pad with TPR padding on back of hand and fingers. Sizes: M, L, XL, XXL.

Item# **MEGY200** Clarino® synthetic palm pad with TPR padding on back of hand and fingers. Sizes: M, L, XL, XXL.

LEATHER DRIVERS

GRAIN GOATSKIN DRIVERS – Soft and strong.



This supple leather contains natural lanolin that helps create a very soft feel. Characteristics include strongest tensile strength and excellent tactile sensitivity. Best combination of flexibility and comfort.

Features

- Premium grain goatskin.
- Exceptional durability.
- Greater softness for sense of touch.
- Excellent tensile strength.
- Shirred elastic back.
- Straight thumb style.
- Color-coded hem to identify size.
- Sizes: S, M, L, XL, XXL, XXXL.



Item# **MEG3601**

SPLIT BACK COW – Rugged cow grain drivers with split leather back.

Gunn pattern, all cow leather gloves feature a tuff cream color grain leather palm with a rugged split leather back. Great all around hand protection.

Features

- Grain leather palm side.
- Split leather back.
- Patch palm.
- Wing thumb.
- Color-coded hem to identify size.
- Sizes: S, M, L, XL.



Item# **MEG32055**

GRAIN COW – Full leather cow grain.

From wranglin' to buildin', these gloves are tough for the job! Cowhide is the most commonly used leather due to availability. Characteristics include a good balance between abrasion resistance, dexterity, durability and comfort.

Features

- Industry grade, full leather glove.
- Keystone thumb.
- Slip-on cuffs.
- Color-coded hem to identify size.
- Sizes: S, M, L, XL, XXL.



Item# **MEG32113**

MCR Safety provides the industry as well as consumers with the very best in safety products.



Protection, Hand

LEATHER PALMS

MUSTANG – Premium grain leather palm.

The top grain leather of the Mustang glove lets you feel what you are working with and holds up to the abrasion better than split leather.



Features

- Premium grain leather palm.
- Durability and dexterity.
- Full feature gunn pattern.
- 2-1/2" Rubberized safety cuffs.
- Sizes: S, M, L, XL.

Applications – Any applications demanding both durability and dexterity, also farming industry, construction, casting, steel and iron work, municipalities and utilities.

Item# **MEG1935**

SPLIT SHOULDER – General purpose for those lighter jobs.



Features

- Low cost leather protection.
- 2-1/2" Rubberized safety cuff.
- Sizes: S, M, L, XL.

Applications – General purpose applications requiring abrasion protection and breathability of leather and cotton, such as assembly, construction, fabricating, landscaping, maintenance, metal working, mining and sanitation.

Item# **MEG12010**

BIG JAKE® – Sewn with Kevlar®.

Big Jake® gloves are used in heavy-duty and rugged requirements – Made for the tough jobs.



Features

- Heavy select chrome tanned side split leather.
- Sewn with super strong, heat resistant DuPont™ Kevlar® thread.
- Generously cut, full featured gunn pattern.
- 2-3/4" Rubberized safety cuffs.
- CE approved and labeled with CE test results.
- Sizes: S, M, L, XL.

Applications – Heavy-duty and rugged requirements, such as assembly, cable construction, farming, foundry, jack hammer operations, iron and steel work, lumberjack and millwright operations, mining, pipe fitting, rebar, rope handling and stamping.

Item# **MEG1700**

CUT RESISTANT – DYNEEMA®

Dyneema® is extremely cool to work in and offers the best abrasion resistance of the high performance fibers.



Features

- 13 Gauge Dyneema®/Nylon/Spandex® shell.
- Breathable and lint free.
- Polyurethane palm and finger coating.
- Color coded hem sizing for easy identification.
- CE 4341, CPPT 2.
- Sizes: XS, S, M, L, XL, XXL.

Applications – Automotive, metal fabrication, ceramics, paper and pulp industry, textile industry and other applications requiring ultimate cut protection.

Item# **MEG9672**

NINJA® MAX – Serious cut protection.

Features

- 10 Gauge shell blended of Dyneema® and silicone free synthetic yard.
- Breathable shell for maximum comfort.
- Proprietary bi-polymer palm and finger coating.
- Color coded hem sizing for easy identification.
- CE 4542, CPPT 3.
- Sizes: S, M, L, XL.



Applications – Automotive, metal fabrication, ceramics, paper and pulp industry, textile industry and other applications requiring ultimate cut protection.

Item# **MEGN9676G**

ULTRATECH® DYNEEMA® – Cut and abrasion protection.

Features

- 13 Gauge Dyneema® shell.
- Salt & Pepper color.
- Gray polyurethane coating.
- Seamless knit.
- High comfort level.
- Allows manual dexterity.
- Washable.
- CE 4343, CPPT 2.
- Sizes: XS, S, M, L, XL, XXL.



Applications – Automotive, metal fabrication, ceramics, paper and pulp industry, textile industry and other applications requiring ultimate cut protection.

Item# **MEG9676**

Protection, Hand

EXPERIENCE THE DIFFERENCE

Protection, Hand

CUT RESISTANT GLOVES

ULTRATECH® KEVLAR® – Cut protection plus dexterity.

Features

- 13 Gauge, 100% Kevlar® brand fiber shell.
- Textured foam black Nitrile coating.
- Seamless Knit.
- High comfort level.
- Allows manual dexterity.
- Sizes: XS, S, M, L, XL, XXL.



Applications – Automotive, metal fabrication, ceramics, paper and pulp industry, textile industry, aerospace, telecommunications, semiconductor industry, electronics, food processing, automotive, glass industry, sharp materials, sheet metal.

Item# **MEG9693**

FLEX TUFF® KEVLAR® – Latex palm coated Kevlar®.

Features

- 100% Kevlar® brand fiber shell.
- CE score 3443.
- Will not melt, ignite or conduct electricity.
- High comfort level.
- Allows manual dexterity.
- Launderable.
- Sizes: S, M, L, XL, XXL.



Applications – Glass handling, canning, bottling, automotive, sheet metal handling, recycling.

Item# **MEG9687**

UNSUPPORTED GLOVES

LATEX – 18 mil thickness.

Features

- 18-Mil Latex canners.
- Straight cuff.
- Amber color.
- 12" Length.
- Embossed grip on palm and fingers.
- Chlorinated for easy on, easy off.
- Component materials comply with FDA regulations for food contact.



Applications – Canning and food-processing industries, janitorial work, maintenance, research and development laboratories, poultry.

Item# **MEG5070E** Size 7 - 7½

Item# **MEG5080E** Size 8 - 8½

Item# **MEG5090E** Size 9 - 9½

Item# **MEG5099E** Size 10 - 10½

MEMPHIS BRAND – Good tactile sensitivity and dexterity.

Features

- Memphis foam seamless gray nylon shell.
- Black foam Nitrile dipped palm and fingers.
- 13 Gauge / CE score 4121.
- Good to excellent tactile sensitivity.
- Excellent comfort and fit.
- Excellent grip.
- Greater dexterity.
- Seamless shell liners.
- Sizes: XS, S, M, L, XL.



Applications – Assembly, manufacturing, small parts handling, general purpose.

Item# **MEG9673**

DOTTED/HONEYCOMB KEVLAR® GLOVES – For added grip.

Features

- 100% Kevlar® regular weight.
- Dotted – 2-sided PVC dots.
- Will not melt, ignite or conduct electricity.
- High comfort level.
- Allows manual dexterity.
- Launderable.
- Sizes: XS, S, M, L, XL.



Applications – Glass handling, canning, bottling, automotive, sheet metal handling, recycling.

Item# **MEG9366**

LINED LATEX – 18 mil thickness.

Features

- 18-Mil thickness.
- Yellow color.
- Straight cuff.
- Embossed grip on palm and fingers.
- Flock lined for easy on, easy off as well as perspiration absorption.
- Component materials comply with FDA regulations for food contact.



Applications – Food-processing industries, janitorial work, poultry, and research laboratories. Caution - These products contain natural rubber latex which may cause allergic reactions in some people.

Item# **MEG5270** Size 7 - 7½

Item# **MEG5280** Size 8 - 8½

Item# **MEG5290** Size 9 - 9½

Item# **MEG5299** Size 10 - 10½

Protection, Hand

UNSUPPORTED GLOVES

NITRILE – 15 mil thickness.

Features

- Made of Nitr-Chem, a synthetic latex (no latex proteins). Excellent alternative for individuals who are allergic to latex.
- Straight cuff.
- Flock lined for easy on, easy off.
- 13" Length.
- Heavy-duty non-slip grip, Diamond grip on palm and fingers.
- Component materials comply with FDA regulations for food contact.



Applications – Provides liquid and basic chemical protection for refining, mining and utilities, petrochemicals, fishing, ship building, handling abrasive materials coated with grease and oil, caustics, acids and solvents.

- Item# **MEG5316** Size 6
- Item# **MEG5317** Size 7
- Item# **MEG5318** Size 8

- Item# **MEG5319** Size 9
- Item# **MEG5320** Size 10
- Item# **MEG5321** Size 11

SUPPORTED/DIPPED GLOVES

FLEXTUFF® LATEX DIPPED – Ergonomic design.

Features

- 10 Gauge cotton/polyester shell.
- Maximum flexibility.
- Blue textured latex palm and fingertip dip.
- Natural rubber provides abrasion resistance.
- Excellent comfort and fit.
- Sizes: S, M, L, XL.



Applications – Material handling, glass handling operations, fishing and plywood industries, sanitation, general maintenance.

Item# **MEG9680**

NINJA® – Natural rubber latex coating.

Features

- 15 Gauge 100% nylon shell.
- Crinkle latex coating providing superb flexibility, elasticity and durability.
- Excellent for dry grip applications.
- Treated with Actifresh to kill bacteria and promote freshness.
- Component materials comply with all relevant federal regulations for food contact.
- Sizes: S, M, L, XL.



Applications – Agriculture, durable goods assembly, food, recycling and warehousing.

Item# **MEGN9680**

SUPPORTED/DIPPED GLOVES

SINGLE DIPPED PVC – Even the dirtiest, harshest jobs won't destroy the will of these tough gloves.



MEG6212R

MEG6300



Features

- Single-dip interlock lining.
- Fully coated.
- Generous sizing.
- Size: L.

Item# **MEG6212** (12" Gauntlet, smooth finish)

Item# **MEG6212R** (12" Gauntlet, rough finish)

Item# **MEG6300** (14" Gauntlet, smooth finish)

BLACK JACK® – Premium multi-dipped neoprene

Features

- 100% Cotton brushed interlock lining.
- Smooth finish / 12" gauntlet cuff.
- Liquid-proof.
- Provides protection against abrasions, cuts, acids, caustics and other hazardous chemicals.
- Features Actifresh® to prevent bacterial buildup.



Item# **MEG6932** Size L

PLYFLEX – Latex with etched finish and freakish flexibility.

Features

- 12" Gauntlet.
- Etched textured latex rubber coating.
- Excellent gripping power even when wet.
- Features Actifresh® to prevent bacterial buildup.
- Sizes: S, M, L, XL, XXL.



Item# **MEG6885**

VINYL COATED GLOVES

WHIZZ-KNIT™ – Vinyl-coated.

Features

- Soft, seamless, interlock knit lining.
- Excellent replacement for cotton canvas gloves.
- Ideal for use in shipping and receiving departments, light assembly and maintenance.
- Slip-on style.
- Sizes: S, M, L.



Item# **MEG9891**

EXPERIENCE THE DIFFERENCE

Protection, Hand

LEATHER WELDERS

Only the finest top grain leathers from pig, cow, goat and deer skins go into making these magnesium inert gas (MIG) and tungsten inert gas (TIG) welding gloves.

MUSTANG MIG/TIG – Welders

Features

- Premium grain cow leather.
- Split cow leather cuff.
- Wing thumb.
- 4.5" Gauntlet.
- Gunn pattern.
- Sewn with super-strong, heat-resistant DuPont™ Kevlar® thread.
- Sizes: S, M, L, XL.



Applications – Low heat welding, mig welding (metal inert gas), tig welding (tungsten inert gas).

Item# **MEG4950**

GLOVES FOR GLORY MIG/TIG – Welders

Features

- Premium grain goatskin leather.
- Split cow leather cuff.
- Gunn pattern.
- Sewn with super-strong, heat-resistant DuPont™ Kevlar® thread.
- Sizes: M, L, XL, XXL.



Applications – Low heat welding, mig welding (metal inert gas), tig welding (tungsten inert gas).

Item# **MEG4850**

BLUE BEAST® – Select heavy side leather with reinforced palm.

Features

- Select heavy side leather.
- Full sock lining, in-sewn at all finger tips.
- All seams fully welted.
- Turned leather hems.
- Flame-resistant sleeves.
- Extra-large die cut.
- Gunn pattern.
- Sewn with super-strong, heat-resistant DuPont™ Kevlar® thread.
- Sizes: XL, XXL.



Applications – Foundry, welding, all general purpose applications requiring heat, flame or spark protection.

Item# **MEG4600**

COTTON GLOVES

COTTON CANVAS PVC – General purpose cotton gloves.



Features

- 8 Oz. woven cotton/poly blend canvas.
- Absorbent.
- 2.5" Knit wrist.
- Straight thumb.
- Size: L.



(MEG8808)

Applications – For comfort and breathability in general purpose applications.

Item# **MEG8808** (PVC dotted palm, index finger, thumb)

Item# **MEG8100A** (Clute pattern)

JERSEYS® –

Brown Jersey gloves.

Features

- Brown Jersey.
- Knit wrist.
- Clute pattern.
- Breathable.
- Absorbent.
- Size: Men's L.



Applications – For comfort and breathability in general purpose applications.

Item# **MEG7100**

STRING KNIT GLOVES – Economy.

Features

- Regular weight, cotton and polyester.
- PVC dots on two sides.
- PVC dots improve grip and provide more abrasion resistance.
- Color coded hem to identify sizes.
- Sizes: M, L, XL.



Applications – Automotive, plants, material handling, bottling industries, package handling, farm and gardening.

Item# **MEG9668**

Protection, Hand

DISPOSABLE GLOVES

NITRISHIELD® – Premium Nitrile disposable gloves.

Made of synthetic latex, they contain no latex proteins and offer excellent resistance to punctures and tears. These gloves are an excellent alternative for individuals with allergic reactions to latex.

Features

- Resistance to a wide variety of chemicals.
- Industrial grade.
- Latex free.

Item# **MEG6015** (NitriSheild® Nitrile, 4 Mil, Industrial Grade, Powder Free, Textured)
 Sizes: S, M, L, XL, XXL.



Item# **MEG6020** (NitriSheild® Nitrile, 4 Mil, Industrial Grade, Powdered, Textured)
 Sizes: S, M, L, XL.



Item# **MEG6025** (NitriSheild®, 8 mil, Industrial Grade, Powdered)
 Sizes: S, M, L, XL.



Applications – Food processing, chemical processing, handling bio-hazards, mail sorting, biomedical and other industrial applications needing tactile sensitivity plus puncture and abrasion resistance.

DURASHIELD NITRILE – Economy Nitrile disposable gloves.

Features

- 4 Mil thickness.
- Resistance to a wide variety of chemicals.
- Food service grade.
- Textured finish for better grip.
- Ambidextrous / Powdered.
- Sizes: S, M, L, XL, XXL.



Applications – Clinical laboratories, nursing home care, dentistry, patient examinations, pharmacy, veterinarian.

Item# **MEG6001**

SENSAGUARD LATEX – Rubber latex is, by its very nature, a natural substance.

Features

- 5 Mil thickness.
- Industrial grade.
- Ambidextrous.
- Non-sterile.
- Sizes: S, M, L, XL.



Applications – Electronic assembly, food processing, laboratory work and general pharmaceutical use.

Item# **MEG5055** (Double Chlorinated, Powder Free)

Item# **MEG5060** (Chlorinated, Powdered)

DISPOSABLE GLOVES



The natural rubber latex polymer used in the manufacture of natural rubber gloves is a natural, biodegradable material that is inherently antimicrobial and antibacterial.

CAUTION: These products contain natural rubber latex which may cause allergic reactions in some people.

MED-TECH – Latex medical grade.

Features

- NFPA certified.
- Powder free latex.
- 11 Mil thickness.
- 12" Length / Rolled cuffs.
- Double chlorinated.
- Ambidextrous.
- Size: S, M, L, XL.



Applications – Biological hazards, emergency response, laboratory technician.

Item# **MEG5049**

SENSATOUCH LATEX – Medical grade disposable.

Features

- 5 Mil thickness.
- Powder free.
- Textured finish for better grip.
- Rolled cuff.
- Double chlorinated.
- Size: S, M, L, XL, XXL.



Applications – Clinical laboratories, patient examinations, dentistry, dental hygiene, pharmacy, nursing home care, veterinarian.

Item# **MEG5045**

CUT RESISTANT SLEEVES

ECONOMY SLEEVES – High performance, string knit hand protection.



Features

- 100% Kevlar®.
- 18" Length.
- High comfort level.
- Allows manual dexterity.
- Made with FDA-accepted materials for use in food processing applications.
- Launderable.
- Size: Universal.

Applications – Advanced manufacturing, automotive industry, electrical work, light heat applications, glass operations, metal stamping, sheet metal, food processing, meat packing.

Item# **MEG9378E**

Protection, Hand

Protection, Hand

GENERAL PURPOSE GLOVES

NITRI-FLEX® PLUS

Nitri-Flex® Plus combines flat-dip technology and a seamless knitted cotton shell to create one of the industry's most comfortable and durable all-purpose work gloves. Palm-dipped in nitrile, Nitri-Flex® Plus delivers comfort and heavy-duty abrasion and puncture resistance.

Characteristics

- Nitrile coating (flat dipped).
- Oil resistance.
- Comfortable cotton seamless lining.
- Knit wrist
- Sizes: 6 (XS), 7 (S), 8 (M), 9 (L), 10 (XL).

Applications – Construction, oily parts handling, mechanics, automotive assembly, maintenance, refineries, garbage collection, highway work, roofing, shipping and receiving.

Item# **BEG4600**



THE ORIGINAL NITTY GRITTY®

Best Original Nitty Gritty® was the industry's first wrinkle-finished, Natural Rubber-coated glove. It remains the most cut resistant comfortable, premium-value glove of its class.

Characteristics

- Palm coated natural rubber.
- Cotton flannel liner.
- Reinforced safety cuff.
- Wrinkle grip.
- Launder at 104°F (40°C), neutral detergent.
- Sizes: 10 (L).

Applications – Mechanical and automotive, construction, wood handling, handling concrete blocks, brick and tile handling, shipping and receiving, inspection, landscaping.

Item# **BEG66NFW-10**



FUZZY DUCK®

Don't let the cuddly name fool you. Fuzzy Duck® is a heavy-duty, general purpose workhorse. The fully-coated PVC supported glove provides workers with a "breathable" option to bulky, inferior cotton or leather chore gloves. And with its textured coating, Fuzzy Duck® delivers enhanced grip and handling as well as abrasion and puncture resistance.

Characteristics

- Fully coated PVC.
- Cotton jersey liner.
- Slip on.
- Textured finish.
- Launderable.
- Printed on both hands for easy pairing.
- Sanitized®.
- Sizes: 8 (S), 9 (M), 10 (L), 11 (XL).

Item# **BEG962**



CHEMICAL RESISTANT GLOVES

BLACK KNIGHT®

The Black Knight® is one of the most durable work gloves available. With cotton lined PVC construction, it provides workers barrier protection from chemicals, oil and grease as well as abrasion resistance.

Characteristics

- PVC coated.
- Cotton jersey liner.
- Rough grip. / Sanitized®.
- Size: 10 (L).

Applications – Manufacturing, utilities, battery manufacturing, paper pulp processing, sand blasting, pellet-blasting applications, fuel handling and refineries, masonry and concrete, hexavalent chromium protection.

Item# **BEG7712R-10** (12" Gauntlet)

Item# **BEG7714R-10** (14" Gauntlet)



NSK 24™

The NSK24™ is a Super Flexible, watertight knit-lined nitrile glove. Providing excellent protection from a wide array of solvents, oils and acids, it has a rough-finish texture that also delivers a sure grip in even the most oily and wet applications.

Characteristics

- 100% Nitrile coated.
- Cotton interlock liner.
- 24" Long.
- Rough textured grip.
- Size: 8 (S), 9 (M), 10 (L), 11 (XL).

Applications – Oily greasy applications, refineries, sewer cleaning, deep-sea fishing, wet cement handling, protection from hexavalent chromium and fuels, painting, masonry, food handling applications.

Item# **BEGNSK24**



BEST® CHEM MASTER™

For a good resistance to a broad range of chemicals, Chem Master™ features a Neoprene-over-Natural Rubber construction that also provides excellent abrasion, tear and puncture resistance.

Characteristics

- Neoprene over natural rubber.
- 26 Mil thickness.
- 12" Long.
- Cotton flock lining.
- Self-flushing tractor-tread grip.
- Sizes: 7 (S), 8 (M), 9 (L), 10 (XL).

Applications – Manufacturing, food processing, battery manufacturing, paper pulp processing, sand blasting, pellet-blasting applications, fuel handling and refineries, masonry and concrete, hexavalent chromium protection.

Item# **BEGCHM**



Protection, Hand

CHEMICAL RESISTANT GLOVES

NEO GRAB™

Characteristics

- Fully neoprene coated.
- Cotton liner.
- Rough grip.
- Sanitized®.
- Limited heat resistance to intermittent contact up to 350°F.
- Size: 10 (L).

Applications – Manufacturing, battery manufacturing, sand blasting, fuel handling and refineries, hexavalent chromium protection, food processing, paper pulp processing, pellet-blasting applications, masonry and concrete.

Item# **BEG6780R-10** (12" Gauntlet)

Item# **BEG6784R-10** (14" Gauntlet)

Item# **BEG6797R-10** (Elbow Length)



14" Gauntlet

Elbow Length

DISPOSABLE GLOVES

N-DEX® ORIGINAL & N-DEX® PLUS

Characteristics

- 100% Nitrile.
- 9.5" Long / Utility grade.
- Light powder / Smooth finish.
- Sizes, N-DEX® Original: 5-6 (XS), 6-7 (S), 7-8 (M), 8-9 (L), 9-10 (XL), 10-11 (XXL), 11-12 (XXXL).
- Sizes, N-DEX® Plus: S, M, L, XL.

Applications

N-DEX® Original – Laboratory, automotive maintenance, painting, crime scene investigation, military applications, food handling, automotive repair, janitorial, electronic applications, law enforcement.

N-DEX® Plus – Emergency medical operations, food processing, janitorial, fuel handling & refineries, manufacturing, laboratories, painting.

Item# **BEG7005** (N-DEX® Original) (4 Mil)

Item# **BEG8005** (N-DEX® Plus) (8 Mil)



HEXARMOR GLOVES AND PROTECTIVE ARM SLEEVES are made with *SuperFabric®* brand material for the highest cut resistance available on the market – Exceeds ISEA/CE Level 5.

CHROME SERIES®: CUT 5 360°

- Synthetic leather palm with PVC grip.
- 360° Level 5 cut resistance.
- Launderable.
- Sizes: 7 (S), 8 (M), 9 (L), 10 (XL), 11 (XXL), 12 (3XL).

Item# **HXA4023**



CHROME SERIES®: CUT 5 IMPACT 360°

- Back of hand impact protection.
- Synthetic leather palm with PVC grip.
- 360° Level 5 cut resistance.
- Oil resistant.
- Launderable.
- Sizes: 7 (S), 8 (M), 9 (L), 10 (XL), 11 (XXL).

Item# **HXA4025**



STELLEATHER® IX

- Comfortable premium split cow leather.
- May be dry-cleaned for repeated use.
- Sizes: 7 (S), 8 (M), 9 (L), 10 (XL), 11 (XXL).

Item# **HXA5039**



9000 SERIES™ 9010

- Innovative industrial puncture protection on enhanced areas from wires, metal, wood and glass.
- Cut-resistant HPPE blend shell with flat nitrile palm coating for great oily or dry grip – ISEA Level 4.
- Launderable.
- Sizes: 7 (S), 8 (M), 9 (L), 10 (XL), 11 (XXL).

Item# **HXA9010**



9000 SERIES™ 9011

- Innovative industrial puncture protection on enhanced areas from wires, metal, wood and glass.
- Cotton blend shell with wrinkle rubber palm coating.
- Launderable.
- Sizes: 7 (S), 8 (M), 9 (L), 10 (XL), 11 (XXL).

Item# **HXA9011**



19" PROTECTIVE ARM SLEEVE

- Innovative industrial puncture protection from wires, metal, wood and glass.
- Lightweight and cool.
- Neoprene thumb loop and sleeve clip.
- Launderable.
- Sizes: 7 (S), 8 (M), 9 (L), 10 (XL), 11 (XXL), 12 (3XL).

Item# **HXAAS019S**



Protection, Hand

EXPERIENCE THE DIFFERENCE



Protection, Head

STANDARD V-GARD® SLOTTED PROTECTIVE CAP

Polyethylene shell and self-adjusting crown straps provide comfortable, lightweight protection. Standard size (6-1/2" to 8").



Features

- Polyethylene shell provides superior impact protection.
- Self-adjusting crown straps ensure a comfortable fit.
- Designed to work with MSA accessories.
- Size: Standard (6-1/2" to 8").

Approvals & Certifications

- ANSI/ISEA Z89.1-2009 (Class E, Type I).
- CSA Z94.1-2005 (Class E, Type I) when assembled with MSA Fas-Trac® or 1-Touch® Suspension.

Item#	Design	Color
MSA463942	Staz-On® Suspension	White
MSA463943	Staz-On® Suspension	Blue
MSA463944	Staz-On® Suspension	Yellow
MSA463945	Staz-On® Suspension	Orange
MSA463946	Staz-On® Suspension	Green
MSA463947	Staz-On® Suspension	Red
MSA463948	Staz-On® Suspension	Gray
MSA488148	Staz-On® Suspension	Hi-Viz® Orange
MSA10057441	1-Touch® Suspension	White
MSA10057442	1-Touch® Suspension	Blue
MSA10057443	1-Touch® Suspension	Yellow
MSA10057444	1-Touch® Suspension	Orange
MSA10057445	1-Touch® Suspension	Green
MSA10057446	1-Touch® Suspension	Red
MSA10057447	1-Touch® Suspension	Gray
MSA10057420	1-Touch® Suspension	Hi-Viz® Orange
MSA10061514	1-Touch® Suspension	Hi-Viz® Yellow-Green
MSA475358	Fas-Trac® Suspension	White
MSA475359	Fas-Trac® Suspension	Blue
MSA475360	Fas-Trac® Suspension	Yellow
MSA475361	Fas-Trac® Suspension	Orange
MSA475362	Fas-Trac® Suspension	Green
MSA475363	Fas-Trac® Suspension	Red
MSA475364	Fas-Trac® Suspension	Gray
MSA488146	Fas-Trac® Suspension	Hi-Viz® Orange
MSA10061512	Fas-Trac® Suspension	Hi-Viz® Yellow-Green



V-GARD® SLOTTED PROTECTIVE HAT

Polyethylene shell and self-adjusting crown straps provide comfortable, lightweight protection. Three size options make these the ideal protectors for the entire work crew.



Features

- Polyethylene shell provides superior impact protection.
- Self-adjusting crown straps ensure a comfortable fit.
- Designed to work with MSA accessories.
- Sizes: Small (6" to 7-1/8", Standard (6-1/2" to 8"), Large (7" to 8-1/2").

Approvals & Certifications

- ANSI/ISEA Z89.1-2009 (Class E, Type I).
- CSA Z94.1-2005 (Class E, Type I) when assembled with MSA Fas-Trac® or 1-Touch® Suspension.
- EN 397.

Item#	Design	Color
MSA454730	Staz-On® Suspension	Yellow
MSA454731	Staz-On® Suspension	Gray
MSA454732	Staz-On® Suspension	Blue
MSA454733	Staz-On® Suspension	White
MSA454734	Staz-On® Suspension	Orange
MSA454735	Staz-On® Suspension	Green
MSA454736	Staz-On® Suspension	Red
MSA489360	Staz-On® Suspension	Hi-Viz® Orange
MSA10058318	1-Touch® Suspension	Yellow
MSA10058319	1-Touch® Suspension	Gray
MSA10058320	1-Touch® Suspension	Blue
MSA10058321	1-Touch® Suspension	White
MSA10058322	1-Touch® Suspension	Orange
MSA10058323	1-Touch® Suspension	Green
MSA10058324	1-Touch® Suspension	Red
MSA10058326	1-Touch® Suspension	Hi-Viz® Orange
MSA10061516	1-Touch® Suspension	Hi-Viz® Yellow-Green
MSA475366	Fas-Trac® Suspension	Yellow
MSA475367	Fas-Trac® Suspension	Gray
MSA475368	Fas-Trac® Suspension	Blue
MSA475369	Fas-Trac® Suspension	White
MSA475370	Fas-Trac® Suspension	Green
MSA475371	Fas-Trac® Suspension	Red
MSA475375	Fas-Trac® Suspension	Orange
MSA10021292	Fas-Trac® Suspension	Hi-Viz® Orange
MSA10061515	Fas-Trac® Suspension	Hi-Viz® Yellow-Green



Protection, Head

V-GARD® 500 VENTED AND NON-VENTED PROTECTIVE CAP

V-Gard® 500 Vented Protective Caps provide cooling vents for improved air circulation and comfort. The non-vented caps are appealing to users who want both the V-Guard 500 style and dielectric head protection.

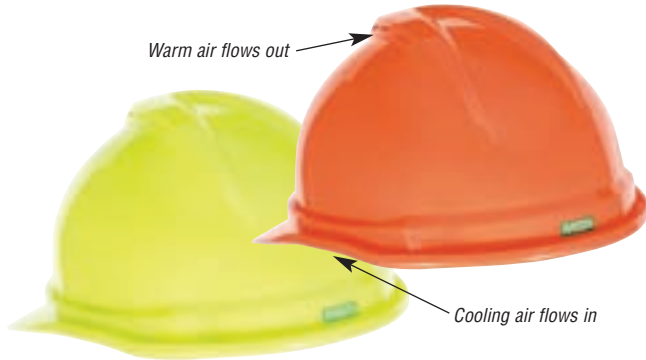

Features

- Vented version for improved air circulation.
- Optional 4- or 6-point suspension system.
- Lightweight design for added comfort.
- Glaregard® Surface underbrim to reduce reflective glare.
- Lateral contours for easy integration of hearing protection.
- Extended rain trough for around-the-brim protection in hot and/or wet environments.
- Size: Standard (6-1/2" to 8").

Approvals & Certifications

- Meet or exceed the applicable requirements for a Type 1 helmet (top impact) as outlined in ANSI Z89.1 2003. Non-Vented meet Class E and Vented meet Class C.

V-GARD® 500 VENTED PROTECTIVE CAP

Item#	Suspension Design	Color
MSA10034018	4-Point Fas-Trac®	White
MSA10034019	4-Point Fas-Trac®	Blue
MSA10034020	4-Point Fas-Trac®	Yellow
MSA10034022	4-Point Fas-Trac®	Red
MSA10034023	4-Point Fas-Trac®	Green
MSA10034026	4-Point Fas-Trac®	Hi-Viz® Orange
MSA10074819	4-Point Fas-Trac®	Hi-Viz® Yellow-Green
MSA10034027	6-Point Fas-Trac®	White
MSA10034028	6-Point Fas-Trac®	Blue
MSA10034029	6-Point Fas-Trac®	Yellow
MSA10034031	6-Point Fas-Trac®	Red
MSA10034032	6-Point Fas-Trac®	Green
MSA10034035	6-Point Fas-Trac®	Hi-Viz® Orange
MSA10074820	6-Point Fas-Trac®	Hi-Viz® Yellow-Green

V-GARD® 500 NON-VENTED PROTECTIVE CAP

Item#	Suspension Design	Color
MSA10034088	4-Point Fas-Trac®	White
MSA10034097	6-Point Fas-Trac®	White

SKULLGARD® NON-SLOTTED PROTECTIVE CAP / HAT

Designed to offer outstanding protection in hot and dangerous industries, the Skullgard Protective Hat sets the standard for environments such as steel mills. This hat can withstand radiant heat loads up to 350°F while still maintaining its protection capabilities.



Features

- Withstands radiant heat loads up to, but not exceeding 350°F.
- Smooth crown for easy use of MSA welding equipment.
- Sizes: Small (6" to 7-1/8"), Standard (6-1/2" to 8"), Large (7" to 8-1/2").

Approvals & Certifications

- ANSI/ISEA Z89.1-2009 (Class G, Type I) Third-party certified by SEI.

SKULLGARD® NON-SLOTTED PROTECTIVE CAP

Item#	Design	Color
MSA454617	Staz-On® Suspension	Natural Tan
MSA454618	Staz-On® Suspension	White
MSA454619	Staz-On® Suspension	Yellow
MSA454620	Staz-On® Suspension	Red
MSA454621	Staz-On® Suspension	Green
MSA454622	Staz-On® Suspension	Gray
MSA454623	Staz-On® Suspension	Blue
MSA454626	Staz-On® Suspension	Orange
MSA458702	Staz-On® Suspension	Hi-Viz® Red-Orange
MSA475395	Fas-Trac® Suspension	Natural Tan
MSA475396	Fas-Trac® Suspension	White
MSA475397	Fas-Trac® Suspension	Yellow

SKULLGARD® NON-SLOTTED PROTECTIVE HAT

Item#	Design	Color
MSA454664	Staz-On® Suspension	Natural Tan
MSA454665	Staz-On® Suspension	White
MSA454666	Staz-On® Suspension	Yellow
MSA454668	Staz-On® Suspension	Green
MSA454673	Staz-On® Suspension	Orange
MSA475407	Fas-Trac® Suspension	Natural Tan
MSA475408	Fas-Trac® Suspension	White

Custom Imprinting available.
Ask your local Abatix sales representative for details.

EXPERIENCE THE DIFFERENCE

Protection, Head

ROUGHNECK® P2

Available in two versions to meet a variety of workplace conditions, Roughneck caps are built to provide exceptional crack resistance and handle hard knocks in the toughest places – without developing the nicks and cracks seen in other fiberglass caps.

Roughneck® P2A:

The P2A series tolerates heat up to 370° while delivering a long service life under many adverse conditions.

Roughneck® P2HN:

The P2HN series is designed for high performance at extremely elevated temperatures up to 500°. In these extreme environments, air circulating over the sweatband lowers the temperature inside the cap – an important comfort feature in high heat applications.



Features

- Proprietary injection-molded fiberglass compound offers exceptional impact and crack resistance and is eight times stronger than common high density polyethylene (HDPE) cap shells.
- Best-in-class heat resistance. Meets ANSI-Z89.1-2009 impact resistance tests at extreme temperatures of up to 370°F (P2A) and up to 500°F (P2HN).
- Solid color resin provides a permanent, no-chip, no-peel finish. Nine popular colors plus **other color options available**.
- **Custom-imprint is available. Ask your local Abatix sales representative for details.**
- Smooth, matte finish makes logo imprints crisper and cleaner, so your official company caps look better and last longer.
- The technically-advanced SuperEight suspension balances and spreads weight over a wide area for added comfort and impact protection.
- Available with the famous Fibre-Metal non-slip/non-strip ratchet, SwingStrap™ or TabLok™ headgear.
- Ready to use with the industry's most versatile Quick-Lok® or Speedy® Loop helmet attachment system for faceshields and welding helmets.
- For added assurance of performance, all Roughneck caps are factory-assembled and SEI third-party certified to meet ANSI Z89.1-2009 Type I Class G (including Quick-Lok® model) and CSA Z94.1-2005 Type I Class G or C (Class C for Quick-Lok® model) in both forward and reverse.

Roughneck® Protective Cap Headgear



TabLok™ Suspension – Adjustable, 360° padded sweatband.

Ratchet Suspension – Strip-proof, crack-proof headband. SEI-certified in both forward and reverse position.

SwingStrap™ Suspension – Reversible ratchet, patented design converts from front-wearing position to rear-wearing position when a welding helmet or faceshield is mounted; no need to reverse the suspension or headband.



Roughneck® P2A

Item#	Suspension	Mounting	Color
FIBP2AW01	TabLok™		White
FIBP2AW02	TabLok™		Yellow
FIBP2AW09	TabLok™		Gray
FIBP2AW11	TabLok™		Black
FIBP2AW12	TabLok™		Brown
FIBP2AW15	TabLok™		Red
FIBP2AW46	TabLok™		Strong Orange
FIBP2AW71	TabLok™		Blue
FIBP2AW74	TabLok™		Green
FIBP2ARW01	Ratchet		White
FIBP2ARW02	Ratchet		Yellow
FIBP2ARW09	Ratchet		Gray
FIBP2ARW11	Ratchet		Black
FIBP2ARW12	Ratchet		Brown
FIBP2ARW15	Ratchet		Red
FIBP2ARW46	Ratchet		Strong Orange
FIBP2ARW71	Ratchet		Blue
FIBP2ARW74	Ratchet		Green
FIBP2AQRW01	Ratchet	Quick-Lok®	White
FIBP2AQRW02	Ratchet	Quick-Lok®	Yellow
FIBP2AQRW09	Ratchet	Quick-Lok®	Gray
FIBP2AQRW11	Ratchet	Quick-Lok®	Black
FIBP2AQRW12	Ratchet	Quick-Lok®	Brown
FIBP2AQRW15	Ratchet	Quick-Lok®	Red
FIBP2AQRW46	Ratchet	Quick-Lok®	Strong Orange
FIBP2AQRW71	Ratchet	Quick-Lok®	Blue
FIBP2AQRW74	Ratchet	Quick-Lok®	Green
FIBP2ASW01	SwingStrap™		White
FIBP2ASW02	SwingStrap™		Yellow
FIBP2ASW09	SwingStrap™		Gray
FIBP2ASW11	SwingStrap™		Black
FIBP2ASW12	SwingStrap™		Brown
FIBP2ASW15	SwingStrap™		Red
FIBP2ASW46	SwingStrap™		Strong Orange
FIBP2ASW71	SwingStrap™		Blue
FIBP2ASW74	SwingStrap™		Green
FIBP2AQSW01	SwingStrap™	Quick-Lok®	White
FIBP2AQSW02	SwingStrap™	Quick-Lok®	Yellow
FIBP2AQSW09	SwingStrap™	Quick-Lok®	Gray
FIBP2AQSW11	SwingStrap™	Quick-Lok®	Black
FIBP2AQSW12	SwingStrap™	Quick-Lok®	Brown
FIBP2AQSW15	SwingStrap™	Quick-Lok®	Red
FIBP2AQSW46	SwingStrap™	Quick-Lok®	Strong Orange
FIBP2AQSW71	SwingStrap™	Quick-Lok®	Blue
FIBP2AQSW74	SwingStrap™	Quick-Lok®	Green

Roughneck® P2HN (High Heat)

Item#	Suspension	Mounting	Color
FIBP2HNRW01	Ratchet		White
FIBP2HNRW02	Ratchet		Yellow
FIBP2HNRW15	Ratchet		Red
FIBP2HNRW46	Ratchet		Strong Orange
FIBP2HNRW71	Ratchet		Blue
FIBP2HNRW74	Ratchet		Green
FIBP2HNQRW01	Ratchet	Quick-Lok®	White
FIBP2HNQRW02	Ratchet	Quick-Lok®	Yellow



Protection, Head

E-2 CAP

The exclusive smooth crown design contains a technically advanced suspension with eight load bearing points to stabilize and balance the hard hat during everyday wear. On impact, the SuperEight® impact energy control system dissipates force by reducing it to smaller increments and spreading it over a greater area. Meets ANSI-Z89.1 TYPE 1, Class E, G, or C.



E-2 Cap & E-1 Full Brim Hat Headgear



TabLok™ Suspension – Adjustable, 360° padded sweatband.

Ratchet Suspension – Strip-proof, crack-proof headband. SEI-certified in both forward and reverse position.

SwingStrap™ Suspension – Reversible ratchet, patented design converts from front-wearing position to rear-wearing position when a welding helmet or faceshield is mounted; no need to reverse the suspension or headband.

E-2 Cap

Item#	Suspension	Color
FIBE2RW01A000	Ratchet	White
FIBE2RW02A000	Ratchet	Yellow
FIBE2RW03A000	Ratchet	Orange
FIBE2RW15A000	Ratchet	Red
FIBE2RW44A000	Ratchet	Hi-Viz Strong Yellow
FIBE2RW46A000	Ratchet	Hi-Viz Orange
FIBE2RW71A000	Ratchet	Blue
FIBE2SW01A000	SwingStrap™	White
FIBE2SW02A000	SwingStrap™	Yellow
FIBE2SW03A000	SwingStrap™	Orange
FIBE2SW15A000	SwingStrap™	Red
FIBE2SW44A000	SwingStrap™	Hi-Viz Strong Yellow
FIBE2SW46A000	SwingStrap™	Hi-Viz Orange
FIBE2SW71A000	SwingStrap™	Blue
FIBE2W01A000	TabLok™	White
FIBE2W02A000	TabLok™	Yellow
FIBE2W03A000	TabLok™	Orange
FIBE2W15A000	TabLok™	Red
FIBE2W44A000	TabLok™	Hi-Viz Strong Yellow
FIBE2W46A000	TabLok™	Hi-Viz Orange
FIBE2W71A000	TabLok™	Blue

Choose from 23 colors for E-2 Caps or E-1 Full Brim Hats.
 Custom Imprinting available.
 Ask your local Abatix sales representative for details



E-2 High Visibility Cap

Item#	Suspension	Tape/Shell Color
FIBE2RW46A289	Ratchet	Ref. Silver/Strong Org.
FIBE2RW44A289	Ratchet	Ref. Silver/Strong Yel.
FIBE2RW44A008	Ratchet	Ref. Strong Org./Strong Yel.
FIBE2RW01A008	Ratchet	Ref. Strong Org./White
FIBE2RW46A009	Ratchet	Ref. Strong Yel./Strong Org.
FIBE2SW01A008	SwingStrap™	Ref. Strong Org./White
FIBE2SW46A009	SwingStrap™	Ref. Strong Yel./Strong Org.
FIBE2SW44A009	SwingStrap™	Strong Org./Strong Yel.
FIBE2W46A009	TabLok™	Strong Yel./Strong Org.

E-1 FULL BRIM HAT

Full brim adds an extra margin of protection from hazardous sun rays and hazardous substances falling onto the neck and shoulders. Meets ANSI-Z89.1 TYPE 1, Class E, G, or C.



E-1 Full Brim Hat

Item#	Suspension	Color
FIBE1RW01A000	Ratchet	White
FIBE1RW02A000	Ratchet	Yellow
FIBE1RW03A000	Ratchet	Orange
FIBE1RW15A000	Ratchet	Red
FIBE1RW44A000	Ratchet	Hi-Viz Strong Yellow
FIBE1RW46A000	Ratchet	Hi-Viz Orange
FIBE1RW71A000	Ratchet	Blue
FIBE1SW01A000	SwingStrap™	White
FIBE1SW02A000	SwingStrap™	Yellow
FIBE1SW03A000	SwingStrap™	Orange
FIBE1SW15A000	SwingStrap™	Red
FIBE1SW44A000	SwingStrap™	Hi-Viz Strong Yellow
FIBE1SW46A000	SwingStrap™	Hi-Viz Orange
FIBE1SW71A000	SwingStrap™	Blue
FIBE1W01A000	TabLok™	White
FIBE1W02A000	TabLok™	Yellow
FIBE1W03A000	TabLok™	Orange
FIBE1W15A000	TabLok™	Red
FIBE1W44A000	TabLok™	Hi-Viz Strong Yellow
FIBE1W46A000	TabLok™	Hi-Viz Orange
FIBE1W71A000	TabLok™	Blue

EXPERIENCE THE DIFFERENCE

Protection, Head



E-1 HIGH VISIBILITY FULL BRIM HAT

Printed protective caps and hats are highly visible – they enhance corporate image, reinforce safety programs and identify trades on the job. The smooth matte finish of a Fibre-Metal hard hat makes imprints crisper and cleaner so your official company caps/hats look better and last longer. Logos, safety slogans and union identification look impressive, thanks to advanced printing technology.

Advantages include:

- Large print areas.
- Multiple print locations.
- Multi-color imprinting.
- Low minimum order quantities.
- Fast turnaround.
- Professional art service available.



E-1 High Visibility Full Brim Hat

Item#	Suspension	Tape/Shell Color
FIBE1W01A008	TabLok™	Ref. Strong Org./White
FIBE1W46A009	TabLok™	Ref. Strong Yel./Strong Org.
FIBE1RW46A289	Ratchet	Ref. Silver/Strong Org.
FIBE1RW44A008	Ratchet	Ref. Strong Org./Strong Yel.
FIBE1RW01A008	Ratchet	Ref. Strong Org./White
FIBE1W46A009	Ratchet	Ref. Strong Yel./Strong Org.
FIBE1RW46A009	Ratchet	Strong Yel./Strong Org.
FIBE1SW46A009	SwingStrap™	Strong Yel./Strong Org.

Custom Imprinting available.

Ask your local Abatix sales representative for details

Abatix' online ordering system is simple to use. Once you are registered and have a customer code, you can create orders, customize shopping lists, and view ordering history, track shipments, view and print invoices and pay bills online. Head over to www.abatix.com and start shopping today.



N-FERNO® – 2-Layer Winter Liner With warming pack pockets for cold conditions.



Applications:

- Construction
- Freight/Baggage
- Drilling/Mining
- Oil/Gas Refining
- Iron/Steel Work
- Delivery/Service
- Landscaping/Grounds
- Cold Storage/Warehousing
- Material Handling

Features

- 2-Layer Cotton/Fleece.
- Shell: 100% cotton twill.
- Lining: 100% poly fleece.
- Single wash FR treated.
- Regular length with hook & loop chin wrap.
- One size.

Item# **ERG16850**

N-FERNO® – 3-Layer Winter Liner w/Fleece Extreme Series with warming pack pockets.



Applications:

- Construction
- Freight/Baggage
- Drilling/Mining
- Oil/Gas Refining
- Iron/Steel Work
- Delivery/Service
- Landscaping/Grounds
- Cold Storage/Warehousing
- Material Handling

Features

- 3-Layer Nylon/Foam/Fleece, single wash FR treated.
- Shell: 100% quilted nylon.
- Mid-Layer: Foam.
- Lining: 100% poly fleece.
- Shoulder length.
- One size.

Item# **ERG16867**



by Honeywell

Protection, Hearing - Earmuffs

LEIGHTNING® SERIES EARMUFFS

Maximum Comfort and Contemporary Design
High performance and robust steel wire durability

- Air Flow Control™ Technology.
- Steel wire construction.

- Snap-in ear cushions.
- Padded foam headband.
- Contemporary earcup design.
- Special application styles.

Leightning Noise Blocking – L3H Cap-Mounted Earmuff

NRR 27 Rated

- For use with wide range of popular hard hats.
- Earcups snap-lock in place during use and can rotate back when not in use.
- Adapter included with each earmuff.

Item# **HLI1011993**



Leightning LOF Folding Earmuff

NRR 23 Rated

- Convenient folding design for easy storage.
- LON ultraslim, lightweight earcups.
- Belt storage case available separately.

Item# **HLI1013461**



Protection, Hearing - Earplugs

MAX LITE® SINGLE-USE EARPLUG

- Ideal size for workers with smaller ear canals.
- Low pressure polyurethane foam expands gently for comfortable long-term wear.
- Contoured T-shape for easy handling and wear.
- Smooth, soil-resistant closed cell-foam skin prevents dirt build-up.
- Optional style with attached cotton cord and paper bag packaging suitable for pulp & paper and other process industries with zero tolerance for packaging waste requirements.
- Bulk refills for Leight Source 400 and Leight Source 500 Earplug Dispensers save time, waste and space.

Item# **HLILPF-1** (Uncorded)
Item# **HLILPF-30** (Corded)

SINGLE-USE EARPLUG

Highest attenuation in single-use earplugs

- The world's most-used polyurethane foam earplug.
- Bell shape delivers maximum in-ear comfort.
- Contoured design easier to insert, resists tendency to back-out of ear canal.
- Polyurethane foam enhances comfort, especially for long-term wear.
- Smooth, soil-resistant closed cell-foam skin prevents dirt build-up.
- Bulk refills for Leight Source 400 and Leight Source 500 Earplug Dispensers save time, waste and space.

Item# **HLIMAX-1** (Uncorded)
Item# **HLIMAX-30** (Corded)



NRR 30 Rated



NRR 33 Rated



NRR 32 Rated

LASER LITE® SINGLE-USE EARPLUG

- Vibrant colors make protection visible.
- Self-adjusting polyurethane foam expands to fit virtually every wearer.
- Contoured T-shape for easy insertion and wear.
- Smooth, soil-resistant closed cell-foam skin prevents dirt build-up.
- Available in paper bag packaging and/or with cotton cords for process industries [pulp & paper].
- Bulk refills for Leight Source 400 and Leight Source 500 Earplug Dispensers save time, waste and space.

Item# **HLILL-1** (Uncorded)
Item# **HLILL-30** (Corded)



NRR 27 Rated

AIRSOFT® MULTIPLE-USE EARPLUG

- Advanced air pocket design features internal noise-blocking fins.
- Four-flange profile creates better seal in the ear canal.
- Less pressure in the ear canal eliminates that “plugged up” feeling.
- Rounded flanges, tapered shape fits better in the ear canal.
- Firm stem facilitates easy insertion and removal.
- Outstanding noise-blocking protection.

Item# **HLIDPAS-30R** (Corded)

Howard Leight Hearing Protection

Your employees deserve the best hearing protection, period. From technical innovations to educational initiatives to field verification, we offer a suite of resources to make hearing conservation happen.

EXPERIENCE THE DIFFERENCE

Protection, Hearing - Earplugs

3M™ UNCORDED FOAM EARPLUGS



Uncorded foam earplugs feature soft, hypoallergenic foam and a tapered design to fit comfortably in the ear canal. NRR 29 dB.

Item# **3M1100**

3M™ E-A-R™ CLASSIC™ UNCORDED EARPLUGS



These earplugs set the standard in hearing protection as the world's first foam earplugs. Constructed from slow-recovery foam, these disposable earplugs are uniquely moisture-resistant. NRR 29 dB.

Item# **AEA312-1080** (*Econopack*)

Packaged in a clean, convenient pillow pack.

Item# **EAR310-1001**

3M™ E-A-Rsoft™ YELLOW NEON™ BLASTS™ UNCORDED EARPLUGS



Neon Blast earplugs that seal the ear canal with soft, slow-recovery foam for excellent noise reduction and comfort. NRR 33 dB. Exciting flame graphics.

Item# **EAR312-1252** (*Poly Bag*)

3M™ CORDED FOAM EARPLUGS



Corded foam earplugs feature soft, hypoallergenic foam and a tapered design to fit comfortably in the ear canal. Equipped with a comfortable, cloth cord to help prevent earplug loss. NRR 29 dB.

Item# **3M1110**

3M™ E-A-R™ CLASSIC™ UNCORDED EARPLUGS



Still one of the most widely used foam earplug today, it is an economical, reliable choice in hearing protection and conservation. Slow recovery, low-pressure foam conforms to the shape of the ear canal to help create a comfortable, snug noise barrier. NRR 29 dB.

Item# **AEA312-1201** (*Poly Bag*)

3M™ E-A-R™ Push-Ins™ CORDED EARPLUGS



Corded foam earplugs provide all-day hearing comfort, convenience and protection. Constructed of 3M™ E-A-Rform™ foam, these earplugs feature a no roll-down design and a blue stem for a quick and easy fit. NRR 28 dB.

Item# **EAR318-1001** (*Poly Bag*)

Warning! These hearing protectors help reduce exposure to hazardous noise and other loud sounds. Misuse or failure to wear hearing protectors at all times that you are exposed to noise may result in hearing loss or injury. For proper use, see supervisor, User Instructions, or call 3M in U.S.A. at 1-800-243-4630. In Canada, call Technical Service at 1-800-267-4414. If there is any drainage from your ear or you have an ear infection, consult with your physician before wearing ear plugs. Failure to do so may result in hearing loss or injury.

Protection, Respiratory - Disposable Masks

N95 PARTICULATE RESPIRATORS



NIOSH Approved

- Inner foam provides a custom seal.
- Dual head strap for optimum fit.
- Maintenance-free.

Item# **SAS8610**



- Exhalation valve for extra comfort.
- Inner foam provides a custom seal.
- Dual head strap for optimum fit.
- Maintenance-free.

Item# **SAS8611**





Protection, Respiratory - Disposable Respirators

3M™ DISPOSABLE FILTERING FACEPIECE RESPIRATORS

Features of 3M™ Filtering Facepiece Respirators

From foundries to wood working, workers in many industries require protection from airborne particles and mists. Sweeping, sanding, grinding, sawing, bagging, welding – each creates a unique set of conditions, especially given environmental considerations such as heat and humidity. 3M's wide selection of filtering facepiece respirators helps you match the respirator to your environment. 3M™ uses a variety of innovative technologies and features to help you meet your protection and comfort needs. They are all NIOSH 42 CFR 84 approved and include the following features:

- Lightweight and comfortable
- Adjustable noseclips / Variety of strap types and of attachments
- Some available with carbon filter material for nuisance level relief*
- Soft inner materials
- Compatible with most eye and hearing protection.

COMFORT

Unvalved N95 Respirators

Suggested Applications: Sweeping, sanding, grinding, sawing, bagging in a non-oil environment.

Features Advanced Electret Media (AEM), welded strap attachment, soft nose foam and adjustable noseclip to help provide a custom fit and secure seal.

Item# **3M8210** (N95)



3M8210

COMFORT PLUS

N95 Respirators

Suggested Applications: Grinding, bagging, sanding, sweeping, extended wear time, hot/humid conditions and other dusty operations. Comfort Plus respirators all feature the proprietary 3M™ Cool Flow™ Exhalation Valve.

Is uniquely designed to help provide protection against certain non-oil based particles. It is ideally suited for work settings that involve heat, humidity, or long periods of wear.

Item# **3M8511** (N95)



3M8511

This three-panel respirator with innovative design is ideally suited for work settings that involve heat, humidity, or long periods of wear.

Item# **3M9211** (N95)



3M9211

* 3M recommended for relief against nuisance level acid gas or organic vapors. Nuisance levels are less than OSHA PEL or applicable government occupational exposure limits, whichever is lower.

COMFORT PLUS (Continued)

100 Class Respirators

Ideal for certain OSHA substance specific contaminants including lead, MDA, arsenic, cadmium (excluding asbestos); additionally for welding, pharmaceutical manufacturing.

Is well suited for those who want NIOSH's highest rated filtration efficiency in a maintenance free respirator. It provides a minimum filter efficiency of 99.97% against non-oil based particles.

Item# **3M8233** (N100)



3M8233

WELDING

Welding and Metal Pouring

Suggested Applications: Welding, torch cutting, brazing, soldering. Welding respirators all feature the proprietary 3M™ Cool Flow™ Exhalation Valve.

Features the 3M™ Cool Flow™ Exhalation Valve, cake-resistant filter media, a comfortable foam face seal and fully adjustable straps.

Additional Applications: Metal pouring

Item# **3M8212** (N95)



3M8212

An economical option for welders featuring the 3M™ Cool Flow™ Exhalation Valve, adjustable M-noseclip, and braided headband to help provide a custom fit and secure seal.

Item# **3M8515** (N95)



3M8515

SPECIALTY

Valved Specialty Respirators

Suggested Applications: Grinding, bagging, sanding, sweeping in oil and non-oil environments and other dusty operations, foundry operation, lab settings, agricultural, petrochemical, manufacturing. Features the proprietary 3M™ Cool Flow™ Exhalation Valve. Suggested for extended wear time, hot/humid conditions.

Is designed to help provide comfortable, reliable worker protection against certain oil and non-oil based particles including those present with nuisance levels of organic vapors* such as solvents, degreasers and resins.

Item# **3M8577** (P95)



3M8577

Warning! These respirators help protect against certain airborne contaminants. Before use, the wearer must read and understand the USER Instructions provided as a part of the product packaging. A written respiratory protection program must be implemented meeting all the requirements of OSHA 1910.134 including training, fit testing and medical evaluation. In Canada, CSA standards Z94.4 requirements must be met and/or requirements of the applicable jurisdiction, as appropriate. Misuse may result in sickness or death. For proper use, see packaging instructions, supervisor, or call 3M OH&ESD Technical Service in USA at 1-800-243-4630 and in Canada at 1-800-267-4414.

EXPERIENCE THE DIFFERENCE

Protection, Respiratory - Half Masks

3M™ HALF FACEPIECE REUSABLE RESPIRATOR



This half facepiece reusable respirator uses advanced silicone material to help provide comfortable and durable respiratory protection. The 3M™ Cool Flow™ Valve helps make breathing easier and can reduce heat and moisture build-up for cool, dry comfort.

- Item# **3M7501** Small
- Item# **3M7502** Medium
- Item# **3M7503** Large

3M™ HALF FACEPIECE REUSABLE RESPIRATOR



This half facepiece reusable respirator offers reliable and convenient respiratory protection and is suitable for many situations, helping provide protection against particulates and a wide variety of gases and vapors according to NIOSH approvals.

- Item# **3M6100** Small
- Item# **3M6200** Medium
- Item# **3M6300** Large

Protection, Respiratory - Full Facepieces

3M™ FULL FACEPIECE REUSABLE RESPIRATOR



This full facepiece reusable respirator offers lightweight comfort and ease of use. Combine with appropriate 3M™ Particulate Filters or Cartridges to help provide respiratory protection against particulates and/or a variety of gases and vapors.

- Item# **3M6700** Small
- Item# **3M6800** Medium
- Item# **3M6900** Large

3M™ FULL FACEPIECE RESPIRATOR, SILICONE



Use with 3M™ Filters 2000 Series, 3M™ Cartridges 6000 Series, 3M™ Cartridges and Filters 7000 Series and powered and supplied air systems against a variety of gases, vapors and particulates according to NIOSH approvals.

- Item# **3M7800S-S** Small
- Item# **3M7800S-M** Medium
- Item# **3M7800S-L** Large

3M™ MOLD REMEDIATION RESPIRATOR KIT



Includes a 3M™ Full Facepiece 6000 and two pairs of 3M™ Particulate Filters 2097, P100, to help reduce exposure to mold and low level organic compounds produced by mold.

- Item# **3M68097** Medium
- Item# **3M69097** Large

Select the Right Respirator

	6000 HF	7500	6000 FF	7800S
Enhanced Durability		•		•
Enhanced Comfort		•	•	
3M™ Cool Flow™ Valve		•	•	
Compatible with 3M™ Supplied Air System	•	•	•	•
Compatible with 3M™ PAPR Systems			•	•
Eye Protection			•	•
Speaking Diaphragm				•
Accessories			•	•
Spare Parts	•	•	•	•
Silicone Faceseal		•	•	•
Compatible with Welding Shield	•	•		
Clip-on Welding Shield				•

Warning! These respirators help protect against certain airborne contaminants. Before use, the wearer must read and understand the USER Instructions provided as a part of the product packaging. A written respiratory protection program must be implemented meeting all the requirements of OSHA 1910.134 including training, fit testing and medical evaluation. In Canada, CSA standards Z94.4 requirements must be met and/or requirements of the applicable jurisdiction, as appropriate. Misuse may result in sickness or death. For proper use, see packaging instructions, supervisor, or call 3M OH&ESD Technical Service in USA at 1-800-243-4630 and in Canada at 1-800-267-4414.



Protection, Respiratory - Cartridges and Filters

3M™ PARTICULATE FILTER, N95 RESPIRATORY PROTECTION



NIOSH approved for environments containing certain non-oil based particles. Use with 3M™ Respirators 5000 Series or 3M™ Cartridges 6000 Series, and 3M™ Filter Retainer 501.

Item# **3M5N11**

3M™ PARTICULATE FILTERS AND GAS/VAPOR CARTRIDGES

All 3M™ Particulate Filters and Gas/Vapor Cartridges can be used interchangeably with 3M™ Reusable Respirators 6000, 7000 and FF-400 Series.

3M™ Particulate Filters 2000 Series and 2200 Series

- Lightweight and easy to breathe through.
- Assortment of filters available for a wide range of applications.
- Easier breathing through new 3-layer advanced Electret Filter Media in 2200 Series Filters.



3M2091



3M2097

Item#	Description
3M2091	Particulate Filter, P100
3M2097	Particulate Filter, P100, with Nuisance Level Organic Vapor Relief*

3M™ Particulate Filter 7093, P100

- Unique, spring-loaded filter cover design simplifies negative pressure user seal checks.
- Swept-back design provides enhanced field of view and greater comfort.
- 3M7093CB offers a lightweight, low profile design that combines P100 filtration with carbon-loaded features found in heavier combination cartridge products.



3M7093B



3M7093CB

Item#	Description
3M7093B	Particulate Filter, P100, Bulk
3M7093CB	Cartridge/Filter, Hydrogen Fluoride, P100 with Nuisance Level Organic Vapor and Acid Gas Relief*

3M™ Gas/Vapor Cartridges 6000 Series

- Low-profile design helps maintain good field of vision.
- Full range of cartridges to meet your needs.



3M6001



3M6003



3M6005



3M6006

Item#	Description
3M6001	Cartridge, Organic Vapor
3M6003	Cartridge, Organic Vapor/Acid Gas**
3M6005	Cartridge, Formaldehyde/Organic Vapor
3M6006	Cartridge, Multi Gas/Vapor**

3M™ Combination Cartridges/P100 Particulate Filters 6000 Series

- Particulate filter is permanently attached to cartridge for easy, one-step assembly.
- Unique design for enhanced comfort and visibility.



3M60921



3M60923



3M60926

Item#	Description
3M60921	Cartridge/Filter, Organic Vapor/P100
3M60923	Cartridge/Filter, Organic Vapor/Acid Gas/P100**
3M60926	Cartridge/Filter, Multi-Gas/Vapor/P100**

* 3M™ recommended for relief against nuisance levels of organic vapors and acid gases. Nuisance level organic vapor and acid gas refers to concentrations not exceeding OSHA PEL or applicable government occupational exposure limits, whichever is lower. Do not use for respiratory protection against acid gases or organic vapors (except hydrogen fluoride).

** Reminder: These cartridges are approved for respiratory protection from hydrogen sulfide gas up to 10 times the permissible exposure limit (PEL) with half facepiece respirators and full facepiece respirators when qualitatively fit tested, or up to less than 300 parts per million (ppm) with full facepiece respirators when quantitatively fit tested or according to specific OSHA standards or applicable government regulations, whichever is lower. 300 ppm is the concentration considered Immediately Dangerous to Life or Health (IDLH) for hydrogen sulfide.

EXPERIENCE THE DIFFERENCE

Protection, Respiratory - Half Masks

7700 AND 5500 SERIES HALF MASKS

The North 7700 half mask is the industry standard for comfort, fit and reliability. The North 5500 is the economical choice for the occasional user, contractor or as a "visitor's mask."



Features

- Can be adapted to PAPR or Supplied Air.
- All parts (only 9) are replaceable.
- Both are latex free.
- 7700 is 100% silicone – no fillers.
- 5500 is thermoplastic elastomeric with a silicone blend.
- Sizes: Small, Medium and Large.

Item# **NSP550030S, M, L**

Item# **NSP770030S, M, L**

NSP550030



NSP770030



Protection, Respiratory - Full Facepieces

7600 SERIES FULL FACEPIECES

How can you improve upon the great fit and comfort of the North 7700 half mask? Give it a picture window. The North 7600 full facepiece features the same craftsmanship and design details that made the 7700 half mask the most popular mask on the market.

5400 SERIES FULL FACEPIECES

The best value you can find in a full facepiece. North innovation, quality and attention to detail come together in an economically priced mask with many standard features our competition consider optional.

NSP76008A



NSP54001



NSP54001W



Features

- Speech diaphragm is standard.
- Soft comfortable silicone construction.
- Can be adapted to PAPR or Supplied Air.
- Five strap head harness.
- Polycarbonate lens (200° field of vision) meets ANSI high impact requirements.
- Sizes: Medium/Large and Small.

Item# **NSP76008A, AS**

Features

- Thermoplastic elastomer construction, has no natural rubber proteins which may cause an allergic reaction.
- Available with welding adapter.
- All parts replaceable. Many replacement parts inter-changeable with the 7600 Series mask.
- Polycarbonate lens (200° field of vision) meets ANSI high impact requirements.
- Sizes: Medium/Large and Small.

Item# **NSP54001, S**

Item# **NSP54001W, SW** (with welding adapter)



Protection, Respiratory - Cartridges & Filters

CARTRIDGES/FILTERS FOR AIR-PURIFYING RESPIRATORS



ITEM#	DESCRIPTION	PROTECTION FROM
GAS AND VAPOR CARTRIDGES		
NSP75SCL	Defender™ Multi-Purpose	Organic vapors, ammonia, methylamine, formaldehyde and acid gases (chlorine, hydrogen chloride, sulfur dioxide, hydrogen sulfide, hydrogen fluoride and chlorine dioxide)
NSPN75001L	Organic Vapor	Organic vapors
NSPN75002L	Acid Gas Cartridge	Acid gases (chlorine, hydrogen chloride, sulfur dioxide, hydrogen fluoride and chlorine dioxide) and formaldehyde
NSPN75003L	Organic Vapor & Acid Gas	Organic vapors and acid gases (chlorine, hydrogen chloride, sulfur dioxide, hydrogen fluoride, hydrogen sulfide and chlorine dioxide)
COMBINATION GAS AND VAPOR CARTRIDGES WITH P100 PARTICULATE FILTERS		
NSP75SCP100L	Defender™ Multi-Purpose with P100	Organic vapors, ammonia, methylamine, formaldehyde and acid gases (chlorine, hydrogen chloride, sulfur dioxide, hydrogen sulfide, hydrogen fluoride and chlorine dioxide); and 99.97% filter efficiency for all particulates
NSP7581P100L	Organic Vapor with P100	Organic vapors; and 99.97% filter efficiency for all particulates
NSP7583P100L	Organic Vapor & Acid Gas with P100	Organic vapors and acid gases (chlorine, hydrogen chloride, sulfur dioxide, hydrogen fluoride, hydrogen sulfide and chlorine dioxide); and 99.97% filter efficiency for all particulates
NSP75852P100L	Mercury Vapor with ESLI and P100	Mercury vapor and chlorine with End-of-Service Life Indicator for mercury; and 99.97% filter efficiency for all particulates
PARTICULATE FILTERS		
NSP7580P100	P100	99.97% filter efficiency for all particulates
NSP7506N95	N95 Prefilter	95% filter efficiency for non-oil based aerosol particulates

Looking for or considering a vending solution? With Abatix Supply Advantage Program – A.S.A.P. vending solutions you could reduce supply costs and improve productivity. Check out our web site to find out more about our A.S.A.P. vending solutions.

Protection, Respiratory - PAPR

3M™ POWERED AIR PURIFYING RESPIRATOR (PAPR)

3M™ Powerflow™ Face-Mounted Powered Air Purifying Respirator (PAPR)

This powered air purifying respirator helps provide respiratory protection against dust, mist, fumes, radionuclides and radon daughters. Lightweight and face-mounted, it uses a high efficiency particulate filter. Ideal for lead and asbestos.

Benefits

- US OSHA APF 1000 when used in accordance with 3M recommendations and user instructions.
- Economically priced. / Compact design fits closely to the wearer.

Item# **3M6800PF** Medium Item# **3M6900PF** Large



3M™ Powerflow™ High Efficiency Particulate Filter (HE), Respiratory Protection System Component

This NIOSH-approved particulate filter helps provide high efficiency (HE) respiratory protection in environments containing particulates. Filter should be used with 3M™ Powerflow™ Powered Air Purifying Respirator (PAPR) systems.

Item# **3M450-01-01R20**



3M™ Versaflo(TM) Hood with Integrated Head Suspension

The 3M™ Versaflo™ S-433L Hood is approved for use with certain 3M™ Powered Air Purifying and Supplied Air Respirator Systems.

Item# **3MS-433L** Medium/Large

Item# **3MS-433S** Small/Medium



Warning! These respirators help protect against certain airborne contaminants. Before use, the wearer must read and understand the USER Instructions provided as a part of the product packaging. A written respiratory protection program must be implemented meeting all the requirements of OSHA 1910.134 including training, fit testing and medical evaluation. In Canada, CSA standards Z94.4 requirements must be met and/or requirements of the applicable jurisdiction, as appropriate. Misuse may result in sickness or death. For proper use, see packaging instructions, supervisor, or call 3M OH&ESD Technical Service in USA at 1-800-243-4630 and in Canada at 1-800-267-4414.



3M™ Belt-Mounted Powered Air Purifying Respirator (PAPR) Assembly

This belt-mounted powered air purifying respirator assembly includes components needed to make a complete PAPR system. Helps provide respiratory protection when combined with 3M™ Headgear and breathing tube.

Benefits

- Rugged, durable PAPR system.
- Wide variety of cartridges and head gear options.

Item# **3MGVP-1**



3M™ Powered Air Purifying Respirator (PAPR) Organic Vapor/Acid Gas/High Efficiency Cartridge

This cartridge is used with the 3M™ Belt-Mounted Powered Air Purifying Respirator (PAPR) Systems. It attaches to the motor blower and filters the air supplied to the headgear.

Item# **3MGVP-443**



3M™ High Efficiency Particulate Filter (HE), for use with GVP-Series Powered Air Purifying Respirator (PAPR)

This NIOSH-approved particulate filter helps provide high efficiency respiratory protection in environments containing particulates. Used with 3M™ GVP Belt-Mounted Powered Air Purifying Respirator Systems.

Item# **3MGVP-440**



3M™ Battery Pack, NiCd, Intrinsically Safe

For use with the 3M™ Breathe Easy™ Turbo Powered Air Purifying Respirator (PAPR) Assembly 520-17-00, Breathe Easy™ Turbo PAPR Unit 022-00-03R01 and the 3M™ Powerflow™ Face-Mounted PAPR System. NIOSH approved with HE cartridges only.

Item# **3MBP17IS**



3M™ Battery Charger

This battery charger will keep the battery properly charged and ready for use.

Item# **3MGVP-112**



Protection,
Respiratory

Protection, Respiratory - Respirator Wipes

RESPIRATOR CLEANING PADS

Large (5" x 8"), individually foil-packaged towelettes contain 70% Isopropanol and are designed specifically for rubber respirator facepieces and other personal safety equipment. The box is designed as a wall mounted dispenser, or can be wall mounted using the box holder.

Item# **NSP7003**



Protection, Respiratory - Fit Test Kits

3M™ QUALITATIVE FIT TEST APPARATUS

This product can be used to check face-to-respirator seal on any particulate respirator or gas/vapor respirator with a particulate pre-filter. It is designed to help your organization meet OSHA fit testing requirements for respirators. 29 CFR 1910.134, Appendix A

Item# **3MFT-10** (Sweet Solution)

Item# **3MFT-30** (Bitter Solution)



Protection, Respiratory - Smoke Test Kits

AIR FLOW INDICATOR KIT

The Sensidyne Air Flow Indicator (HVAC) Kit is highly recommended to track air flow currents and for fit testing respirators per OSHA 29 CFR part 1910.134, irritant fume protocol.

Item# **SES500** (Smoke Tube Air Flow Indicator Kit (HVAC). Includes an Aspirator Bulb, Tube Tip Breakers [package of 5] and a Carrying Pouch.)

Item# **SES501** (Smoke Tubes, Box of 10)



Protection, Respiratory - Respirator Bag

DRAWSTRING RESPIRATOR BAG

- Clear plastic bag (3 mil).
- Cotton drawstring.
- 16" x 12".

Item# **MSA465008**



EXPERIENCE THE DIFFERENCE

Protective Clothing - Microporous

MAXGUARD MP MICROPOROUS COVERALLS

MAXGUARD MP utilizes state-of-the-art lamination technology to combine a soft non-woven fabric with a microporous film. This technology allows us to offer a fabric with superior liquid barrier and better particulate barrier.

Technical Data

Test	Method	Result
Bleach 5%	ASTM T903	Pass
Hydraulic Jack Oil	ASTM T903	Pass
Isocyanate Based Paint Hardener	ASTM T903	Pass
Motor Oil	ASTM T903	Pass
Sodium Hydroxide	ASTM T903	Pass
Mineral Oil	ASTM T903	Pass

Test	Method	Result
Fabric Weight (g/m)	GB/T 4669-1995	60.2
Water Vapor Transmission (g/m 24h)	GB/T 12074-1991	1500
Water Resistance (Kpa)	FZ/T 01004-1991	18.8
Flat Abrasion	FZ/T 01001-1991	198
Breaking Strength (N/5cm)	GB/T 3923.1-1997	Radial: 70 / Woof: 50
Elongation at Break (%)	GB/T 3923.1-1997	Radial: 60 / Woof: 50
Tear Strength (N5cm)	ASTM D2261-1996	Radial: N/A / Woof: 8.6
Electric Charge Density (uC/m)	GB/T 5455-1997	6.5
Flammability	GB/T 4744-1997	Melt-down
Dry Particle Filtration Efficiency		No Particle Penetration
Wet Particle Filtration Efficiency		No Particle Penetration

Property	Unit	MAXGUARD		Tyvek	Method
		MP	KG XP (KC)		
MD Tensile Strength	lbf/in	31.5	30.6	24	ASTM D50345
CD Tensile Strength	lbf/in	17.3	21.4	17.5	ASTM D50345
MD Elongation	%	85	72	31	ASTM D50345
CD Elongation	%	102	89	23	ASTM D50345
MD Tear Strength	lbf/in	13.0	11.0	6.2	INDA IST 100.2
CD Tear Strength	lbf/in	7.1	7.2	5.2	INDA IST 100.2
Hydrohead	cmHO	171	187	112	AATCC 127
Flammability		Class 1	Class 1	Class 1	CPSC 1610

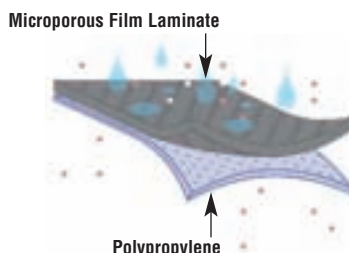

Elastic wrist, open ankle

Hood/boot, elastic wrist/ankle

- Item# **MAXMP12-L**
- Item# **MAXMP12-XL**
- Item# **MAXMP12-2XL**
- Item# **MAXMP12-3XL**
- Item# **MAXMP12-4XL**

- Item# **MAXMP19-L**
- Item# **MAXMP19-XL**
- Item# **MAXMP19-2XL**
- Item# **MAXMP19-3XL**
- Item# **MAXMP19-4XL**

MICROGUARD MP™ COVERALLS



MicroGuard MP™ utilizes state-of-the-art lamination technology to combine a soft non-woven fabric with a microporous film. This technology allows us to offer a fabric with superior liquid barrier, better particulate barrier, stronger tear resistance, and lower lint than other fabrics. An excellent alternative to TYVEK®, KleenGuard® XP, and MicroMax, this newest line of quality garments offers superior worker comfort yet it is also strong and durable.

MicroGuard MP™ is for use in, but not limited to:

- Handling and applying granular powder or dust pesticides
- Fiberglass manufacturing and installation
- Industrial, research and clinical facilities
- Pharmaceutical and food processing
- Woodworking and furniture manufacturing
- Construction and asbestos abatement sites.

As always, it is the user's responsibility to determine the proper protective apparel required for each application.

ENVIROGUARD

Hood only coverall, elastic wrist and ankle. White.

- Item# **IES8015-M** (Medium)
- Item# **IES8015-L** (Large)
- Item# **IES8015-XL** (Extra Large)
- Item# **IES8015-2XL** (2X Large)
- Item# **IES8015-3XL** (3X Large)
- Item# **IES8015-4XL** (4X Large)

Elastic wrist and open ankle. White.

- Item# **IES8012-M** (Medium)
- Item# **IES8012-L** (Large)
- Item# **IES8012-XL** (Extra Large)
- Item# **IES8012-2XL** (2X Large)
- Item# **IES8012-3XL** (3X Large)
- Item# **IES8012-4XL** (4X Large)



Protective Clothing - SMS

SMS COVERALLS



ENVIROGUARD

International Enviroguard's SMS provides worker comfort and additional protection in the workplace. SMS is made of a 60 GSM fabric. These breathable garments provide an excellent particulate barrier, along with a barrier for light splashes and spray.

Uses

- General clean-up work.
- Asbestos and lead abatement.
- Mold remediation.
- Manufacturing.
- Assembly operations.
- Laboratories.
- Printing.
- Dirt, dust, grime environments.

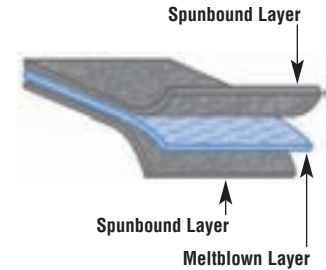

Standard coverall, elastic wrist and back. White

White

- Item# **IES2222M** (Medium)
- Item# **IES2222L** (Large)
- Item# **IES2222XL** (Extra Large)
- Item# **IESC2222-2XL** (2X Large)
- Item# **IESC2222-3XL** (3X Large)
- Item# **IESC2222-4XL** (4X Large)

Standard coverall, hood and boot, elastic wrist.

White

- Item# **IES2229M** (Medium)
- Item# **IES2229L** (Large)
- Item# **IES2229XL** (Extra Large)
- Item# **IES2229-2XL** (2X Large)
- Item# **IES2229-3XL** (3X Large)
- Item# **IES2229-4XL** (4X Large)

Denim Blue

- Item# **IES2229BM** (Medium)
- Item# **IES2229BL** (Large)
- Item# **IES2229BXL** (Extra Large)
- Item# **IES2229B-2XL** (2X Large)
- Item# **IES2229B-3XL** (3X Large)
- Item# **IES2229B-4XL** (4X Large)



Protective Clothing - Polypropylene



DISPOSABLE COVERALLS

Polypropylene is a lightweight, breathable fabric that provides economical protection against dirt and grime and for use in certain hazardous and non-hazardous workplaces. These include industrial facilities, pharmaceuticals, food processing, construction and environmental clean-up sites.

Coveralls with hood and boot, zipper front, elastic wrist. White.

30 Gram Material:

- Item# **IES2019-M** (Medium)
- Item# **IES2019-L** (Large)
- Item# **IES2019-XL** (Extra Large)
- Item# **IES2019-2XL** (2X Large)
- Item# **IES2019-3XL** (3X Large)
- Item# **IES2019-4XL** (4X Large)

50 Gram Material:

- Item# **IES2029-M** (Medium)
- Item# **IES2029-L** (Large)
- Item# **IES2029-XL** (Extra Large)
- Item# **IES2029-2XL** (2X Large)
- Item# **IES2029-3XL** (3X Large)
- Item# **IES2029-4XL** (4X Large)

Protective Clothing - Specialty

VIROGUARD™ – FOR JOBS INVOLVING HAZARDOUS LIQUIDS



Introducing ViroGuard™, a new line of protective apparel for hazardous liquids in unique applications. This new line of protective apparel is comfortable to wear and offers breathability through enhanced moisture vapor transmission yet holds out many dangerous liquids and particulates. This fabric passes ASTM F1670/1671 testing for blood, body fluids and blood-borne pathogens. It is the user's responsibility to determine the proper protective apparel.

Blood-borne Pathogen and Splash Protection

- Category 3 black water applications.
- Clinical research and facilities.
- Emergency response.
- Crime scene remediation.
- Animal research.



Blue hood and boot coverall w/ elastic wrist and back, front zipper w/ storm flap (25/case)

- Item# **IES2404-M** (M)
- Item# **IES2404-L** (L)
- Item# **IES2404-XL** (XL)
- Item# **IES2404-2XL** (2XL)
- Item# **IES2404-3XL** (3XL)
- Item# **IES2404-4XL** (4X)
- Item# **IES2404-5XL** (5XL)

Blue hood only coverall w/ elastic wrist ankle and back, zipper front w/ storm flap (25/case)

- Item# **IES2407-M** (M)
- Item# **IES2407-L** (L)
- Item# **IES2407-XL** (XL)
- Item# **IES2407-2XL** (2XL)
- Item# **IES2407-3XL** (3XL)
- Item# **IES2407-4XL** (4X)
- Item# **IES2407-5XL** (5XL)

ENVIROGUARD

BODY FILTER 95+™ – ADVANCED PARTICLE PROTECTION



- Full body protective filtration garment.
- Protection for particulate matter in the range of 0.3 microns.

Enviroguard™ Body Filter 95+™ incorporates the highest quality in electrostatically charged filter media into a superior filtration system. Exceptional abrasion resistance is provided by a unique apertured molded hard plastic polymer grid on the surface. An interior silky smooth skin contact surface wicks moisture away from the body.

Standard coverall w/ elastic wrist, open ankle (25/case)

- Item# **IES4012-M** (M)
- Item# **IES4012-L** (L)
- Item# **IES4012-XL** (XL)
- Item# **IES4012-2XL** (2XL)
- Item# **IES4012-3XL** (3XL)
- Item# **IES4012-4XL** (4XL)

Coverall w/ elastic wrist and ankle (25/case)

- Item# **IES4017-M** (M)
- Item# **IES4017-L** (L)
- Item# **IES4017-XL** (XL)
- Item# **IES4017-2XL** (2XL)
- Item# **IES4017-3XL** (3XL)
- Item# **IES4017-4XL** (4XL)

Coverall w/ attached hood, elastic wrist & ankle (25/case)

- Item# **IES4028-M** (M)
- Item# **IES4028-L** (L)
- Item# **IES4028-XL** (XL)
- Item# **IES4028-2XL** (2XL)
- Item# **IES4028-3XL** (3XL)
- Item# **IES4028-4XL** (4XL)

Coverall with attached hood and boot, elastic wrist (25/case)

- Item# **IES4014-M** (M)
- Item# **IES4014-L** (L)
- Item# **IES4014-XL** (XL)
- Item# **IES4014-2XL** (2XL)
- Item# **IES4014-3XL** (3XL)
- Item# **IES4014-4XL** (4XL)

ENVIROGUARD

Protective Clothing - Chemical

CHEMSPLASH 1®



BREATHABLE IMPERVIOUS PROTECTION

ENVIROGUARD® CHEMSPLASH 1® combines the economy of micro-porous technology with a revolutionary process of creating a surface augmented with additional polymers. The resultant Hybrid Breathable Membrane System is a transformed barrier which retains “breathability” for worker comfort while resisting many chemicals found in the workplace. The seams are stitched and then taped to provide added safety from incidental chemical splash. Also available with serged seams.

ACCIDENTAL CHEMICAL SPLASH PROTECTION

Enviroguard® Chemsplash 1® is tested for chemical penetration and permeation resistance by exposure to accidental liquid splash to a specific list of industrial chemicals (ISO 6350 & EN 368).

- The world’s first breathable chemical splash barrier for many toxic industrial chemicals.
- Impervious (ISO 6350*) to hazardous chemicals while minimizing heat stress.

* Protection against liquid chemicals. Determination of resistance of materials to penetration by liquids.



CHEMSPLASH 1® Coveralls with taped seams

Standard coverall with elastic wrist, open ankle and taped seams (6/case)

- Item# **IES7012YT-S** (S)
- Item# **IES7012YT-M** (M)
- Item# **IES7012YT-L** (L)
- Item# **IES7012YT-XL** (XL)
- Item# **IES7012YT-2XL** (2XL)
- Item# **IES7012YT-3XL** (3XL)
- Item# **IES7012YT-4XL** (4XL)

Coverall with elastic wrist and elastic ankle, and taped seams (6/case)

- Item# **IES7013YT-S** (S)
- Item# **IES7013YT-M** (M)
- Item# **IES7013YT-L** (L)
- Item# **IES7013YT-XL** (XL)
- Item# **IES7013YT-2XL** (2XL)
- Item# **IES7013YT-3XL** (3XL)
- Item# **IES7013YT-4XL** (4XL)

Coverall with attached hood, elastic wrist and ankle, and taped seams (6/case)

- Item# **IES7015YT-S** (S)
- Item# **IES7015YT-M** (M)
- Item# **IES7015YT-L** (L)
- Item# **IES7015YT-XL** (XL)
- Item# **IES7015YT-2XL** (2XL)
- Item# **IES7015YT-3XL** (3XL)
- Item# **IES7015YT-4XL** (4XL)

Coverall with attached hood and boot, elastic wrist and taped seams (6/case)

- Item# **IES7019YT-S** (S)
- Item# **IES7019YT-M** (M)
- Item# **IES7019YT-L** (L)
- Item# **IES7019YT-XL** (XL)
- Item# **IES7019YT-2XL** (2XL)
- Item# **IES7019YT-3XL** (3XL)
- Item# **IES7019YT-4XL** (4XL)

CHEMSPLASH 1® Coveralls with serged seams

Standard coverall with elastic wrist, open ankle and serged seams (12/case)

- Item# **IES7012YS-S** (S)
- Item# **IES7012YS-M** (M)
- Item# **IES7012YS-L** (L)
- Item# **IES7012YS-XL** (XL)
- Item# **IES7012YS-2XL** (2XL)
- Item# **IES7012YS-3XL** (3XL)
- Item# **IES7012YS-4XL** (4XL)

Coverall with elastic wrist and elastic ankle, and serged seams (12/case)

- Item# **IES7012YS-S** (S)
- Item# **IES7012YS-M** (M)
- Item# **IES7012YS-L** (L)
- Item# **IES7012YS-XL** (XL)
- Item# **IES7012YS-2XL** (2XL)
- Item# **IES7012YS-3XL** (3XL)
- Item# **IES7012YS-4XL** (4XL)

Coverall with attached hood, elastic wrist and ankle, and serged seams (12/case)

- Item# **IES7012YS-S** (S)
- Item# **IES7012YS-M** (M)
- Item# **IES7012YS-L** (L)
- Item# **IES7012YS-XL** (XL)
- Item# **IES7012YS-2XL** (2XL)
- Item# **IES7012YS-3XL** (3XL)
- Item# **IES7012YS-4XL** (4XL)

Coverall with attached hood and boot, elastic wrist and serged seams (12/case)

- Item# **IES7012YS-S** (S)
- Item# **IES7012YS-M** (M)
- Item# **IES7012YS-L** (L)
- Item# **IES7012YS-XL** (XL)
- Item# **IES7012YS-2XL** (2XL)
- Item# **IES7012YS-3XL** (3XL)
- Item# **IES7012YS-4XL** (4XL)

Don't see what you are looking for? Ask your Abatix Sales Representative. Abatix carries tens of thousands of products. We will make sure you get what you need, when you need it, where you need it.

Protective Clothing - Chemical

CHEMSPLASH 2®



ENVIROGUARD

INCREASED CHEMICAL PROTECTION AGAINST A BROAD RANGE OF CHEMICALS WITH SUPERIOR PHYSICAL STRENGTH

Chemsplash 2® utilizes an Enviroguard proprietary laminated fabric with broad range chemical protection. In addition, Chemsplash 2® offers increased physical strength for industrial workers engaged in mixing chemicals, clean ups, chemical loading operations, and general chemical and petro-chemical environments.

Standard coverall with elastic wrist, open ankle and taped seams (6/case)

- Item# **IES7212GT-M** (M)
- Item# **IES7212GT-L** (L)
- Item# **IES7212GT-XL** (XL)
- Item# **IES7212GT-2XL** (2XL)
- Item# **IES7212GT-3XL** (3XL)
- Item# **IES7212GT-4XL** (4XL)

Coverall with elastic wrist and elastic ankle, and taped seams (6/case)

- Item# **IES7213GT-M** (M)
- Item# **IES7213GT-L** (L)
- Item# **IES7213GT-XL** (XL)
- Item# **IES7213GT-2XL** (2XL)
- Item# **IES7213GT-3XL** (3XL)
- Item# **IES7213GT-4XL** (4XL)

Coverall with attached hood, elastic wrist and ankle, and taped seams (6/case)

- Item# **IES7215GT-M** (M)
- Item# **IES7215GT-L** (L)
- Item# **IES7215GT-XL** (XL)
- Item# **IES7215GT-2XL** (2XL)
- Item# **IES7215GT-3XL** (3XL)
- Item# **IES7215GT-4XL** (4XL)

Coverall with attached hood and boot, elastic wrist and taped seams (6/case)

- Item# **IES7219GT-M** (M)
- Item# **IES7219GT-L** (L)
- Item# **IES7219GT-XL** (XL)
- Item# **IES7219GT-2XL** (2XL)
- Item# **IES7219GT-3XL** (3XL)
- Item# **IES7219GT-4XL** (4XL)

ChemMAX® 1 – Entry Level Chemical Protective Garment

ChemMax® is constructed with a unique polyethylene barrier film and a continuous filament polypropylene nonwoven. ChemMax® 1, cost effective entry level garments, bar many harmful contaminants from penetrating to inner clothing.

Physical Property	Test Method	Units	Test Results
Basis Weight	ASTM D3776	oz./yd. ²	2.29 oz./yd. ²
Grab Tensile MD	ASTM D5034	lbs.	35.0 lbs.
Grab Tensile XD	ASTM D5034	lbs.	27.0 lbs.
Trapezoidal Tear MD	ASTM D5733	lbs.	13.8 lbs.
Trapezoidal Tear XD	ASTM D5733	lbs.	14.2 lbs.
Ball Burst	ASTM D751	lbs.	25.5 lbs.



Serged Seam

A serged seam joins two pieces of material with a thread that interlocks. This is an economical stitching method for general applications. It is more commonly found on limited use clothing where dry particles are of a concern.



Sewn and Bound Seam

A sewn and bound seam joins two pieces of material with an overlay of similar material and is chain stitched through all of the layers for a clean finished edge. This provides increased holdout of liquids and dry particulates.

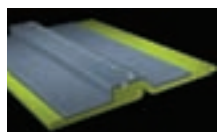

Heat Sealed Seam

A heat sealed seam is sewn and then sealed with a heat activated tape. This method provides liquid proof seams, and is especially useful for Level A and B chemical protective clothing.

Lakeland



Continued on next page



Protective Clothing - Chemical

ChemMAX® 1 (Continued)
Entry Level Chemical Protective Garment

Protective Clothing



Coverall, Zipper closure.

<i>Serged Seam</i>	<i>Sewn & Bound Seam</i>	<i>Heat Sealed Seam</i>
Item# LAKC5412-S	Item# LAKC55412-S	Item# LAKC70100-S
Item# LAKC5412-M	Item# LAKC55412-M	Item# LAKC70100-M
Item# LAKC5412-L	Item# LAKC55412-L	Item# LAKC70100-L
Item# LAKC5412-XL	Item# LAKC55412-XL	Item# LAKC70100-XL
Item# LAKC5412-2XL	Item# LAKC55412-2XL	Item# LAKC70100-2XL
Item# LAKC5412-3XL	Item# LAKC55412-3XL	Item# LAKC70100-3XL
Item# LAKC5412-4XL	Item# LAKC55412-4XL	Item# LAKC70100-4XL
Item# LAKC5412-5XL	Item# LAKC55412-5XL	Item# LAKC70100-5XL



Coverall, zipper closure, attached hood, boots, elastic wrists.

<i>Serged Seam</i>	<i>Sewn & Bound Seam</i>	<i>Heat Sealed Seam</i>
Item# LAKC5414-S	Item# LAKC55414-S	Item# LAKC70150-S
Item# LAKC5414-M	Item# LAKC55414-M	Item# LAKC70150-M
Item# LAKC5414-L	Item# LAKC55414-L	Item# LAKC70150-L
Item# LAKC5414-XL	Item# LAKC55414-XL	Item# LAKC70150-XL
Item# LAKC5414-2XL	Item# LAKC55414-2XL	Item# LAKC70150-2XL
Item# LAKC5414-3XL	Item# LAKC55414-3XL	Item# LAKC70150-3XL
Item# LAKC5414-4XL	Item# LAKC55414-4XL	Item# LAKC70150-4XL
Item# LAKC5414-5XL	Item# LAKC55414-5XL	Item# LAKC70150-5XL



Coverall, zipper closure, elastic wrists and ankles.

<i>Serged Seam</i>	<i>Sewn & Bound Seam</i>	<i>Heat Sealed Seam</i>
Item# LAKC5417-S	Item# LAKC55417-S	Item# LAKC70110-S
Item# LAKC5417-M	Item# LAKC55417-M	Item# LAKC70110-M
Item# LAKC5417-L	Item# LAKC55417-L	Item# LAKC70110-L
Item# LAKC5417-XL	Item# LAKC55417-XL	Item# LAKC70110-XL
Item# LAKC5417-2XL	Item# LAKC55417-2XL	Item# LAKC70110-2XL
Item# LAKC5417-3XL	Item# LAKC55417-3XL	Item# LAKC70110-3XL
Item# LAKC5417-4XL	Item# LAKC55417-4XL	Item# LAKC70110-4XL
Item# LAKC5417-5XL	Item# LAKC55417-5XL	Item# LAKC70110-5XL



Coverall, zipper closure, attached hood, elastic wrists and ankles.

<i>Serged Seam</i>	<i>Sewn & Bound Seam</i>	<i>Heat Sealed Seam</i>
Item# LAKC5428-S	Item# LAKC55428-S	Item# LAKC70130-S
Item# LAKC5428-M	Item# LAKC55428-M	Item# LAKC70130-M
Item# LAKC5428-L	Item# LAKC55428-L	Item# LAKC70130-L
Item# LAKC5428-XL	Item# LAKC55428-XL	Item# LAKC70130-XL
Item# LAKC5428-2XL	Item# LAKC55428-2XL	Item# LAKC70130-2XL
Item# LAKC5428-3XL	Item# LAKC55428-3XL	Item# LAKC70130-3XL
Item# LAKC5428-4XL	Item# LAKC55428-4XL	Item# LAKC70130-4XL
Item# LAKC5428-5XL	Item# LAKC55428-5XL	Item# LAKC70130-5XL

Protective Clothing - Chemical

ChemMAX® 2

Proven protection of Dow Saranex 23P barrier film



ChemMAX® 2 is the second level of barrier protection in the new ChemMAX® line of products. The unparalleled strength and softness of ChemMAX® 2 features Dow Saranex 23P film on two layers of a unique bi-component spunbond nonwoven substrate and provides protection for chemical mixing and handling, environmental clean up, hazardous materials remediation and response, pharmaceutical manufacturing, spray painting and general industry. ChemMAX® 2 is useful in protecting against hazardous chemicals and contaminants found in the work place.

Physical Property	Test Method	Units	Test Results
Basis Weight	ASTM D3776	oz./yd. ²	4.3 oz./yd. ²
Grab Tensile MD	ASTM D5034	lbs.	47.0 lbs.
Grab Tensile XD	ASTM D5034	lbs.	33.9 lbs.
Trapezoidal Tear MD	ASTM D5733	lbs.	29.95 lbs.
Trapezoidal Tear XD	ASTM D5733	lbs.	12.47 lbs.
Ball Burst	ASTM D751	lbs.	48.0 lbs.
Static Decay	NFPA 99	Pass/Fail	Pass



Sewn and Bound Seam

A sewn and bound seam joins two pieces of material with an overlay of similar material and is chain stitched through all of the layers for a clean finished edge. This provides increased holdout of liquids and dry particulates.

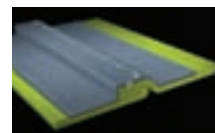

Heat Sealed Seam

A heat sealed seam is sewn and then sealed with a heat activated tape. This method provides liquid proof seams, and is especially useful for Level A and B chemical protective clothing.



Coverall, Zipper closure.

	<i>Sewn & Bound Seam</i>	<i>Heat Sealed Seam</i>
Item#	LAKC44412-S	LAKC72100-S
Item#	LAKC44412-M	LAKC72100-M
Item#	LAKC44412-L	LAKC72100-L
Item#	LAKC44412-XL	LAKC72100-XL
Item#	LAKC44412-2XL	LAKC72100-2XL
Item#	LAKC44412-3XL	LAKC72100-3XL
Item#	LAKC44412-4XL	LAKC72100-4XL
Item#	LAKC44412-5XL	LAKC72100-5XL



Coverall, zipper closure, elastic wrists and ankles.

	<i>Sewn & Bound Seam</i>	<i>Heat Sealed Seam</i>
Item#	LAKC44417-S	LAKC72110-S
Item#	LAKC44417-M	LAKC72110-M
Item#	LAKC44417-L	LAKC72110-L
Item#	LAKC44417-XL	LAKC72110-XL
Item#	LAKC44417-2XL	LAKC72110-2XL
Item#	LAKC44417-3XL	LAKC72110-3XL
Item#	LAKC44417-4XL	LAKC72110-4XL
Item#	LAKC44417-5XL	LAKC72110-5XL



Coverall, zipper closure, attached hood, boots, elastic wrists.

	<i>Sewn & Bound Seam</i>	<i>Heat Sealed Seam</i>
Item#	LAKC44414-S	LAKC72150-S
Item#	LAKC44414-M	LAKC72150-M
Item#	LAKC44414-L	LAKC72150-L
Item#	LAKC44414-XL	LAKC72150-XL
Item#	LAKC44414-2XL	LAKC72150-2XL
Item#	LAKC44414-3XL	LAKC72150-3XL
Item#	LAKC44414-4XL	LAKC72150-4XL
Item#	LAKC44414-5XL	LAKC72150-5XL



Coverall, zipper closure, attached hood, elastic wrists and ankles.

	<i>Sewn & Bound Seam</i>	<i>Heat Sealed Seam</i>
Item#	LAKC44428-S	LAKC72130-S
Item#	LAKC44428-M	LAKC72130-M
Item#	LAKC44428-L	LAKC72130-L
Item#	LAKC44428-XL	LAKC72130-XL
Item#	LAKC44428-2XL	LAKC72130-2XL
Item#	LAKC44428-3XL	LAKC72130-3XL
Item#	LAKC44428-4XL	LAKC72130-4XL
Item#	LAKC44428-5XL	LAKC72130-5XL



Protective Clothing - Chemical

ChemMAX® 3
The highest level of ChemMax® protection available.



Ideal for the industrial environment as well as emergency responders and law enforcement, ChemMax® 3 uses the latest technology to produce a superior product. Durable and lightweight, ChemMax® 3 provides a barrier against a broad spectrum of toxic industrial chemicals, dual use chemicals, chemical warfare agents and other harmful contaminants.

The multi-layer film is applied to a heavy polypropylene nonwoven for increased strength and durability. The barrier film is significantly softer than other products on the market, resulting in a quiet, more comfortable garment.

Put your trust in a ChemMAX® 3 garment and you will feel confident that you are doing your best to protect your team from the dangers lurking around them.

Physical Property	Test Method	Units	Test Results
Basis Weight	ASTM D3776	oz./yd. ²	4.5 oz./yd. ²
Grab Tensile MD	ASTM D5034	lbs.	58.7 lbs.
Grab Tensile XD	ASTM D5034	lbs.	42.2 lbs.
Trapezoidal Tear MD	ASTM D5733	lbs.	25.6 lbs.
Trapezoidal Tear XD	ASTM D5733	lbs.	19.8 lbs.
Ball Burst	ASTM D751	lbs.	54.5 lbs.

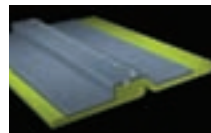

Heat Sealed Seam

A heat sealed seam is sewn and then sealed with a heat activated tape. This method provides liquid proof seams, and is especially useful for Level A and B chemical protective clothing.



Coverall, Zipper closure.

Heat Sealed Seam

- Item# LAKC3T100-S
- Item# LAKC3T100-M
- Item# LAKC3T100-L
- Item# LAKC3T100-XL
- Item# LAKC3T100-2XL
- Item# LAKC3T100-3XL
- Item# LAKC3T100-4XL
- Item# LAKC3T100-5XL



Coverall, zipper closure, elastic wrists and ankles.

Heat Sealed Seam

- Item# LAKC3T110-S
- Item# LAKC3T110-M
- Item# LAKC3T110-L
- Item# LAKC3T110-XL
- Item# LAKC3T110-2XL
- Item# LAKC3T110-3XL
- Item# LAKC3T110-4XL
- Item# LAKC3T110-5XL



Coverall, zipper closure, attached hood, boots, elastic wrists.

Heat Sealed Seam

- Item# LAKC3T150-S
- Item# LAKC3T150-M
- Item# LAKC3T150-L
- Item# LAKC3T150-XL
- Item# LAKC3T150-2XL
- Item# LAKC3T150-3XL
- Item# LAKC3T150-4XL
- Item# LAKC3T150-5XL



Coverall, zipper closure, attached hood, elastic wrists and ankles.

Heat Sealed Seam

- Item# LAKC3T130-S
- Item# LAKC3T130-M
- Item# LAKC3T130-L
- Item# LAKC3T130-XL
- Item# LAKC3T130-2XL
- Item# LAKC3T130-3XL
- Item# LAKC3T130-4XL
- Item# LAKC3T130-5XL

EXPERIENCE THE DIFFERENCE

Protective Clothing - Tyvek®

Tyvek® garments are composed of flash spun high density polyethylene which creates a unique, nonwoven material available only from DuPont. Tyvek® provides an ideal balance of protection, durability and comfort of any limited use fabric technology. Tyvek® fabric offers an inherent barrier to small size hazardous particles. Protection is built into the fabric itself; there are no films or laminates to abrade or wear away. Tyvek® fabric's durability advantage over microporous film and SMS fabrics delivers consistently better barrier, even after wear and abrasion. Applications include: lead and asbestos abatement/remediation, general maintenance/operations, spray painting, general clean-up.

DUPONT™ TYVEK® COVERALLS Comfort Fit Design w/Collar

Features

- Comfort fit design based on extensive wearer input to provide our most comfortable garment design that: enables a greater range of movement while stretching and bending, provides a more tailored fit, offers reinforcement in high stress areas for fewer blowouts, utilizes a longer zipper for easier donning and doffing and an elastic waist to better position the garment.
- Laydown collar.
- Open wrists and ankles.
- Elastic waist.
- Serged seams.
- White.

- Item# DUPTY120SWH-SM
- Item# DUPTY120SWH-MD
- Item# DUPTY120SWH-LG
- Item# DUPTY120SWH-XL
- Item# DUPTY120SWH-2X
- Item# DUPTY120SWH-3X
- Item# DUPTY120SWH-4X
- Item# DUPTY120SWH-5X
- Item# DUPTY120SWH-6X
- Item# DUPTY120SWH-7X



Finished Dimensions

Size	Sleeve Length	Chest Width	Inseam	Fits Chest	Fits Height
SM	34	25	28½	36¾ - 40¼	5'-5'7"
MD	34	25	28½	36¾ - 40¼	5'3"-5'7"
LG	35½	26½	29½	39¾ - 43¼	5'5"-5'9"
XL	37	28	30	42¾ - 46¼	5'8"-6'2"
2X	38½	29¼	31	45¼ - 48¾	6'0"-6'4"
3X	38½	31¼	32	49¼ - 52¾	6'2"-6'4"
4X	39	33	33	52¾ - 56¼	6'4"-6'7"
5X	40	34½	34	55¾ - 59¼	6'7"-6'10"
6X	41½	36¼	35	59¼ - 62¾	6'9"-7'1"
7X	42½	37½	36	61¾ - 65¼	7'0"-7'4"

DUPONT™ TYVEK® COVERALLS Comfort Fit Design w/Respirator Fit Hood

Features

- Comfort fit design based on extensive wearer input to provide our most comfortable garment design that: enables a greater range of movement while stretching and bending, provides a more tailored fit, offers reinforcement in high stress areas for fewer blowouts, utilizes a longer zipper for easier donning and doffing and an elastic waist to better position the garment.
- Attached respirator-fit hood with elastic around face opening, designed to cover neck and chin and fit around respirator face mask.
- Longer zipper extends to chin for complete coverage of neck area.
- Elastic opening for tighter fit at wrist.
- Attached Tyvek® FC boots have special coating to provide added skid-resistance.
- Serged seams.
- White.

- Item# DUPTY122SWH-SM
- Item# DUPTY122SWH-MD
- Item# DUPTY122SWH-LG
- Item# DUPTY122SWH-XL
- Item# DUPTY122SWH-2X
- Item# DUPTY122SWH-3X
- Item# DUPTY122SWH-4X
- Item# DUPTY122SWH-5X
- Item# DUPTY122SWH-6X
- Item# DUPTY122SWH-7X



Finished Dimensions

Size	Sleeve Length	Chest Width	Inseam	Fits Chest	Fits Height	Men Shoe	Women Shoe
SM	33½	25	28	36¾ - 40¼	5'-5'7"	10	12
MD	33½	25	28	36¾ - 40¼	5'3"-5'7"	10	12
LG	35	26½	29	39¾ - 43¼	5'5"-5'9"	15	17
XL	36½	28	29½	42¾ - 46¼	5'8"-6'2"	15	17
2X	38	29¼	30½	45¼ - 48¾	6'0"-6'4"	19	21
3X	38	31¼	31½	49¼ - 52¾	6'2"-6'4"	19	21
4X	38½	33	32½	52¾ - 56¼	6'4"-6'7"	19	21
5X	39½	34½	33½	55¾ - 59¼	6'7"-6'10"	19	21
6X	41	36¼	34½	59¼ - 62¾	6'9"-7'1"	19	21
7X	42	37½	35½	61¾ - 65¼	7'0"-7'4"	19	21

Don't see what you are looking for? Ask your Abatix Sales Representative. Abatix carries tens of thousands of products. We will make sure you get what you need, when you need it, where you need it.

Protective Clothing - Flame Resistant

PYROGUARD™ FR COVERALLS



PyroGuard™ FR garments are intended to be worn over primary flame resistant apparel and are flame retardant treated.

PYROGUARD™ CRFR COVERALLS



ENVIROGUARD

PyroGuard™ FR garments are made with a tough, breathable, light-weight, and cloth like material. The material is wood pulp free for added durability. Wood pulp disintegrates when exposed to water or liquids. The material is topically treated with a phosphate-based flame retardant chemical. The addition of flame retardant chemistry causes the fabric to char at temperatures below the fabric's ignition point. This action deprives flames with a fuel source and provides a rigid structure for the component polymers to adhere to. The result is no flaming or molten drip.

Features

- Disposable garments that protect primary FR apparel.
- Passes NFPA 701, 1989 and 1999 methods.
- Generous sizing to prevent rip-outs.
- Protect primary FR apparel from dirt, grease and non-toxic liquids.
- High MVTR for increased worker comfort.

Standard coverall with elastic wrist and open ankle.

- Item# **IES9012-M** (Medium)
- Item# **IES9012-L** (Large)
- Item# **IES9012-XL** (Extra Large)
- Item# **IES9012-2XL** (2X Large)
- Item# **IES9012-3XL** (3X Large)
- Item# **IES9012-4XL** (4X Large)



Hood and Boot coverall with elastic wrist.

- Item# **IES9019-M** (Medium)
- Item# **IES9019-L** (Large)
- Item# **IES9019-XL** (Extra Large)
- Item# **IES9019-2XL** (2X Large)
- Item# **IES9019-3XL** (3X Large)
- Item# **IES9019-4XL** (4X Large)



Increased chemical protection against a broad range of chemicals with flash fire protection that meets NFPA 2113.

PyroGuard® CRFR utilizes an Enviroguard™ proprietary laminated fabric with broad range chemical protection and flash fire protection. In addition, it offers increased physical strength for industrial workers engaged in mixing chemicals, clean ups, chemical loading operations, and general chemical and petro-chemical environments.

Features

- Sealed seams.
- Self extinguishing.
- No dripping or melting.
- Can be worn over primary FR protective coveralls to extend their life and keep them clean.



Coverall with attached respirator hood, elastic wrist and taped seams (6/case)

- Item# **IES9115T-M** (M)
- Item# **IES9115T-L** (L)
- Item# **IES9115T-XL** (XL)
- Item# **IES9115T-2XL** (2XL)
- Item# **IES9115T-3XL** (3XL)
- Item# **IES9115T-4XL** (4XL)
- Item# **IES9115T-5XL** (5XL)
- Item# **IES9115T-6XL** (6XL)

Coverall with attached respirator hood, attached boot, elastic wrist and taped seams (6/case)

- Item# **IES9119T-M** (M)
- Item# **IES9119T-L** (L)
- Item# **IES9119T-XL** (XL)
- Item# **IES9119T-2XL** (2XL)
- Item# **IES9119T-3XL** (3XL)
- Item# **IES9119T-4XL** (4XL)
- Item# **IES9119T-5XL** (5XL)
- Item# **IES9119T-6XL** (6XL)

EXPERIENCE THE DIFFERENCE



Protective Clothing - Flame Resistant

NOMEX® IIIA 4.5 OZ. FR

ATPV = 4.6 Cal/Cm²
HRC 1

Features Include:

- Leaf collar
- Seven, double stitched pockets (2 chest, 2 rear, 2 hip, 1 tool)
- Elastic waist
- Nomex® IIIA zipper front closure
- Non-sparking covered snaps on lapel, wrists, and pass-through pockets
- Bar tacked stress points
- One-piece action back design
- Garment fabric and components meet NFPA 2112
- Listed by UL
- Meets or Exceeds NFPA 70E, 1971, 1975, 1977
- ASTM F1506 Arc Thermal Performance Tested.



Nomex® IIIA 4.5 oz. fabric is engineered to provide optimum performance for industrial secondary protective clothing. Nomex® IIIA is a high temperature aramid fiber, which is permanently flame resistant with excellent chemical resistance. Nomex® IIIA will not melt or drip when exposed to flames or arcs. Nomex® IIIA is widely recognized as a premier fabric providing protection against the possible exposure to flame or arc.

Available Colors: Khaki (KH), Navy Blue (NV)

- Item# **NMXJS1525-S**
- Item# **NMXJS1525-M**
- Item# **NMXJS1525-L**
- Item# **NMXJS1525-XL**
- Item# **NMXJS1525-XXL**
- Item# **NMXJS1525-3XL**
- Item# **NMXJS1525-4XL**
- Item# **NMXJS1525-5XL**
- Item# **NMXJS1525-6XL**



Protective Clothing

FLAME RESISTANT COVERALLS

Protection from heat, flames and flash fires.



One piece bi-swing back prevents bunching and binding for ease of motion. Durable, self-locking, brass zipper extends service life, opens from top or bottom for convenience. User preferred five pocket design keeps tools, parts and papers at hand for increased productivity. Pocket snap closures insure that nothing is dropped or lost. Covered snaps at waist, top of zipper and neck prevent the snaps from scratching or damaging work or equipment.

Laundry Instructions

100% cotton. Clean garment thoroughly. Detergent only. Dry cleanable. Wash up to 165°F (74°C). NO CHLORINE BLEACH OR HYDROGEN PEROXIDE EITHER SEPARATELY OR IN DETERGENTS. No softeners or starch.

Failure to launder properly could adversely affect the flame resistance of the fabric.

Coverall Size Chart

SIZE	S	M	L	XL	2XL	3XL
Chest	40	44	48	52	56	60
Waist	34	38	42	46	50	54
Hip	36	40	44	48	52	56
Leg Inseam	32	32	32	32	32	32
Sleeve Length						
Center Back	29	31	33	35	36	37
Shoulder	22	23	24	25	26	27
Sleeve Inseam	18	19	20	21	22	22
Trunk	32	32	32	32	34	36
Neck	19	20	20	21	21	22

- Item# **FRC9NB-S** (Navy Blue)
- Item# **FRC9NB-M** (Navy Blue)
- Item# **FRC9NB-L** (Navy Blue)
- Item# **FRC9NB-XL** (Navy Blue)
- Item# **FRC9NB-2XL** (Navy Blue)
- Item# **FRC9NB-3XL** (Navy Blue)
- Item# **FRC9TN-S** (Tan)
- Item# **FRC9TN-M** (Tan)
- Item# **FRC9TN-L** (Tan)
- Item# **FRC9TN-XL** (Tan)
- Item# **FRC9TN-2XL** (Tan)
- Item# **FRC9TN-3XL** (Tan)

Abatix' online ordering system is simple to use. Once you are registered and have a customer code, you can create orders, customize shopping lists, and view ordering history, track shipments, view and print invoices and pay bills online. Head over to www.abatix.com and start shopping today.

Protective Clothing - Shoe and Boot Covers

BOOT COVERS



Yellow Latex Nuke Boot
 Item# **IES2513Y-XL** (X Large)
 Item# **IES2513Y-2XL** (2X Large)



MicroGuard MP™ Boot Cover, 17" High
 Item# **IES8102** (White)

SHOE COVERS

ENVIROGUARD



Blue Polypropylene Anti-Skid Shoe Cover
 Item# **IES3100-3XL** (3X Large)



MicroGuard MP™ Shoe Cover, Vinyl Sole
 Item# **IES8105** (XL) (White)

DUPONT™ TYVEK® SHOE COVER
 Shoe Cover with Tyvek® Sole

Tyvek® garments are composed of flash spun high density polyethylene which creates a unique, nonwoven material available only from DuPont. Tyvek® provides an ideal balance of protection, durability and comfort of any limited use fabric technology. Tyvek® fabric offers an inherent barrier to small size hazardous particles. Protection is built into the fabric itself; there are no films or laminates to abrade or wear away. Tyvek® fabric's durability advantage over microporous film and SMS fabrics delivers consistently better barrier, even after wear and abrasion. Applications include: lead and asbestos abatement/remediation, general maintenance/operations, spray painting, general clean-up.

Features

- 5" High shoe cover with elastic top.
- Serged seams.
- White.
- One size fits most.

Item# **DUPTY450S**



DUPONT™ TYVEK® FC SHOE COVER
 Shoe Cover with Tyvek® FC Skid Resistant Sole

Tyvek® FC – a DuPont™ Tyvek® protective fabric with a skid resistant friction coating. Used exclusively for shoe and boot covers and skid-resistant booties in select Tyvek® coveralls.

Features

- 5" High shoe cover with elastic top.
- Sole material composed of Tyvek® FC, a special coating to provide added slip-resistance.
- Serged seams.
- Gray.
- One size fits most.

Item# **DUPFC450SG**



Protective Clothing - Aprons and Sleeves

DURAGUARD APRONS

ENVIROGUARD



DuraGuard fabric has been tested for liquid chemical penetration using ASTM F903-96, *Standard Test Method for Resistance of Materials Used in Protective Clothing to Penetration to Liquids* (5 minutes at no pressure, 1 minute at 2 psi and 54 minutes at no pressure). Depending on chemical concentrations, exposure potential or use conditions, a higher level of protection may be required.

- Features
- 35" x 55"
 - White

Item# **IES6102-55** (One Size)

36" DENIM APRON
Do It Right – and look good doing it in Denim!



- Features
- 36" Long.
 - 100% Denim Material.
 - 2 Pockets.
 - Aprons with neck and side straps sewn into garments.
 - Denim is Cool and Comfortable.
 - Protects from a wide array of dry non-hazardous particles.

Item# **MEG39836** (One Size)



MCR'S denim products offer a cool and comfortable option to keep clothing clean while working in those gritty and grimy applications. The dark color hides dirt and stains while the rugged material holds up to the tough challenges you face each day.

DUPONT™ TYVEK® SLEEVES



Tyvek® garments are composed of flash spun high density polyethylene which creates a unique, nonwoven material available only from DuPont. Tyvek® provides an ideal balance of protection, durability and comfort of any limited use fabric technology. Tyvek® fabric offers an inherent barrier to small size hazardous particles. Protection is built into the fabric itself; there are no films or laminates to abrade or wear away. Tyvek® fabric's durability advantage over microporous film and SMS fabrics delivers consistently better barrier, even after wear and abrasion. Applications include: lead and asbestos abatement/remediation, general maintenance/operations, spray painting, general clean-up.

- Features
- Elastic at both ends (bicep and wrist) for arm protection.
 - 18" Long.
 - Serged seams.
 - White
 - One size fits most.

Item# **DUPTY500SW**





Rainwear & Boots

RAINSUITS



CLASSIC – Yellow

Features

- 3-Piece – jacket, detachable hood, bib pants.
- Versatile, good for outdoor or indoor use.
- Perfect for construction, utilities, airlines, municipalities and more.
- 0.35mm PVC on polyester broadloom fabric. / Welded seams.
- Plastic snap storm fly front and take up snaps at wrists, waist and ankles.
- Detachable drawstring hood.
- Rounded collar, plain back.
- 2 Patch pockets with flap on jacket (no pockets on pants).
- Raglan sleeve (no underarm air vents).
- Elastic insert adjustable suspenders.
- Reinforced crotch, plastic snap fly front.

SIZING – Item# **RCR2003**+Size (Example - RCR2003L)

JACKET	S	M	L	XL	X2	X3	X4	X5	X6	X7
Chest	49	52	54	57	60	63	65	67	69	71
Sweep	49	52	54	57	60	63	65	67	69	71
Back Length	28	30	31	32	33	34	35	36	37	38
Top Of Sleeve	28.5	30	31.5	32.5	33.5	34.5	35.5	36.5	37.5	38.5
Bottom Of Sleeve	16	17	17	19	19	19	21	21	22	22
Cuffs On Sleeve	7	7.25	7.5	7.5	7.75	7.75	8	8	8.5	8.5
Collar	17.5	17.5	18	18	18.5	18.5	19	19	19.5	19.5
Hood Height	14	14	14.5	14.5	15	15	15.5	15.5	15.5	15.5
Hood Crown Width	11	11	11.5	11.5	12	12	12.5	12.5	12.5	12.5
PANTS	S	M	L	XL	X2	X3	X4	X5	X6	X7
Waist	44	46	48	50	52	54	56	58	60	62
Inseam	26.5	27.5	28.5	29.5	30.5	31.5	32.5	33.5	34.5	35.5
Outseam	39.5	41	42.5	44	45.5	47	48.5	50	51.5	53
Top/Bib To Crotch	21	21	22	23	23	25	26	27	28	29
Cuff	10	10	10.5	10.5	10.5	11	11	11	11	11



DOMINATOR – Green

Features

- 2-Piece – jacket (attached hood), bib pants.
- Tough scrim material double coated with two thick layers of PVC for a combined thickness of .42mm.
- Limited flammability (ASTM D-6413).
- Protects against many chemicals and acids.
- Welded seams / Nylon zipper.
- Double storm flap front and take up snaps at ankles.
- Rounded collar, plain back. / No pockets.
- Tapered raglan sleeve (no underarm air vents).
- Full Elastic adjustable suspenders.
- Reinforced crotch, no fly front.

SIZING – Item# **RCR3882**+Size (Example - RCR3882X4)

JACKET	S	M	L	XL	X2	X3	X4	X5	X6	X7
Chest	54	56	58	60	62	64	66	68	70	72
Sweep	50	52	54	56	60	62	64	66	68	70
Back Length	29.5	30.5	31.5	32	33	34	35	36	37	38
Top Of Sleeve	31	32	33	34	35	36	37	38	39	40
Bottom Of Sleeve	18	19	20	21	22	22	23	23	24	24
Cuffs On Sleeve	7	7	7.5	7.5	8	8	8	8	8.5	8.5
Collar	19	20	20	20	21	22	23	24	25	25
Hood Height	16	16	16	16	16	16	16	16	16	16
Hood Crown Width	11.5	11.5	11.5	11.5	11.5	11.5	11.5	11.5	11.5	11.5
PANTS	S	M	L	XL	X2	X3	X4	X5	X6	X7
Waist	44	46	48	50	52	54	56	58	58	60
Inseam	29	30	31	32	33	33	34	34	35	35
Outseam	42	43	44	45	46	46	47	47	48	48
Top/Bib to Crotch	20.5	21	22	22.5	23.5	24.5	25.5	26.5	27.5	28.5
Cuff	10	10	11	11	11.5	11.5	12	12	12	12



WIZARD – Yellow

Features

- 3-Piece – jacket, detachable hood, bib pants.
- Protects against most chemicals, oils and acids.
- Limited flammability (ASTM D-6413).
- Resistant to snags and tears.
- 0.28mm PVC/Nylon Scrim/PVC.
- Welded seams.
- Plastic snap storm fly front and take up snaps at wrists, waist and ankles.
- Detachable drawstring hood.
- Rounded collar, plain back.
- No pockets on jacket or pants.
- Raglan sleeve (no underarm air vents).
- Elastic insert adjustable suspenders.
- Reinforced crotch, plastic snap fly front.

SIZING – Item# **RCR3003**+Size (Example - RCR3003XL)

JACKET	S	M	L	XL	X2	X3	X4	X5
Chest	49	52	54	57	60	63	65	67
Sweep	49	52	54	57	60	63	65	67
Back Length	28	30	31	32	33	34	35	36
Top Of Sleeve	28.5	30	31.5	32.5	33.5	34.5	35.5	36.5
Bottom Of Sleeve	16	17	17	19	19	19	21	21
Cuffs On Sleeve	7	7.25	7.5	7.5	7.75	7.75	8	8
Collar	17.5	17.5	18	18	18.5	18.5	19	19
Hood Height	14	14	14.5	14.5	15	15	15.5	15.5
Hood Crown Width	11	11	11.5	11.5	12	12	12.5	12.5
PANTS	S	M	L	XL	X2	X3	X4	X5
Waist	44	46	48	50	52	54	56	58
Inseam	26.5	27.5	28.5	29.5	30.5	31.5	32.5	33.5
Outseam	39.5	41	42.5	44	45.5	47	48.5	50
Top/Bib To Crotch	21	21	22	23	23	25	26	27
Cuff	10	10	10.5	10.5	10.5	11	11	11

EXPERIENCE THE DIFFERENCE

Rainwear & Boots



CT™ Economy Safety Hi Boots

A long list of advanced comfort features balanced with an economic price tag, CT (Comfort Technology) offers a unique scalloped top-line design to accommodate flexing in the calf area to reduce irritation as well as graduated boot heights that are consistent with shoe sizes for better fit and comfort.

The unique Trac10™ sole design enhances traction and durability with an ergonomic frame design and interior lugs. The contour heel cup molding reduces heel slippage while the EVA FOOT FORM provides sneaker-like comfort for all-day wear. Sleek and contemporary, the CT Knee Boot is a great choice for general industrial conditions. Steel toe boot meets ASTM F2413-11M I/75 C/75. Men's Whole Sizes: 3-15.



Item# **ABXSTB** (Black, Steel Toe)
Item# **NFI18822** (Black, Plain Toe)

PRO® Safety Hi Boots

Expertly engineered for durability and comfort, Servus PRO™ is specially formulated to withstand deterioration. Developed with TDT, Servus PRO footwear withstands the organic chemical deterioration common in meat processing and petrochemical industries.



- Seamless, waterproof comfort with 3-stage molded construction.
- Outsole compounds formulated for long wear and slip resistance.
- Removable and washable ergonomic insoles.
- Extended ribbed steel shank for support.
- Yellow midsole trimline indicates steel toe.
- Graduated heights decrease calf chaffing.
- TDT™ self-cleaning outsole.
- FOOT FORM™ contour comfort.
- Colors: Gray, Yellow, Black.
- Meets ASTM F2413-11M I/75 C/75.
- Men's Whole Sizes: 5-15

Item# **NFI75101** (Steel Toe)

HAZMAX® KNEEBOOT – The finest boots made for Hazardous Material Handling.

Use in situations involving dangerous chemicals, gasses or biological hazards and waste.



Features and Benefits

- 16" Boot height.
- Steel toe complies with ASTM F2413-11 and CSA Z195.
- Exceeds CSA standards for Dielectric Footwear.
- Limited flash fire protection for **escape only** in the event of a chemical fire.
- Steel toe, steel shank, and steel midsole for complete protection.
- One-piece injection molded construction – no seams.
- Boots are constructed of a high viscosity and flexible PVC alloy.
- Non-absorbent polyester lining for easy cleaning and quick drying.
- Replaceable cushioned insoles.
- Cut off bands.
- Kick off lug.
- Men's Sizes: 6-15.

Item# **BAS87012** (Steel Toe, Shank, Midsole)

Looking for or considering a vending solution? With Abatix Supply Advantage Program – A.S.A.P. vending solutions you could reduce supply costs and improve productivity. Check out our web site to find out more about our A.S.A.P. vending solutions.



Safety Wear - Vests

MAX ECONOMY CLASS 2 WITH TWO-TONE TRIM



- Features
- Closure: Zipper.
 - 2" Silver tape reflective material, 1 horizontal stripe.
 - Contrasting trim detail.
 - Pockets: 1 upper left front, 1 lower right inside.
 - Material: 100% polyester mesh.
 - Colors: Hi-Viz Green and Orange.
 - Sizes: M, L, XL, 2X, 3X, 4X, 5X
- Item# **MAXSV22-2ZOM** (Orange)
Item# **MAXSV22-2ZGM** (Green)

MAX TWO-TONE SURVEYOR CLASS 2 VEST



- Features
- Closure: Zipper.
 - 2" silver tape reflective material, 1 horizontal stripe.
 - Contrasting trim detail.
 - Pockets: 1 split pad/pencil, 1 radio, 2 each lower flap covered, 2 each deep inside pockets.
 - Material: 100% polyester, solid front and mesh back.
 - Colors: Hi-Viz Green and Orange.
 - Sizes: S, M, L, XL, 2X, 3X, 4X, 5X
- Item# **MAXSV60** (Orange)
Item# **MAXSV6G** (Green)

MAX ECONOMY CLASS 2 VEST WITH ZIPPER CLOSURE



- Features
- Closure: Zipper.
 - 2" Silver tape reflective material, 1 horizontal stripe.
 - Pockets: 1 upper left front, 1 lower right inside.
 - Material: 100% polyester mesh.
 - Colors: Hi-Viz Green and Orange.
 - Sizes: S, M, L, XL, 2X, 3X, 4X, 5X
- Item# **MAXSV2ZOM** (Orange)
Item# **MAXSV2ZGM** (Green)

MAX ECONOMY SURVEYOR SOLID AND MESH, 1" PRISMATIC TAPE



- Features
- Closure: Zipper.
 - Prismatic gloss reflective material, 1 horizontal stripe.
 - Contrasting trim detail
 - Pockets: Upper split pad/pencil, upper radio/phone, 2 each lower. Flap covered, 2 large deep open inside, 1 inside flashlight.
 - Materials: 100% polyester solid twill front, 100% polyester mesh back.
 - Colors: Hi-Viz Green and Orange
 - Size: Fits Medium - 5X
- Item# **MAXSV61-NZOD** (Orange)
Item# **MAXSV61-NZGD** (Green)

MAX ECONOMY CLASS 3 WITH TWO-TONE TRIM



- Features
- Closure: Zipper.
 - 2" Silver tape reflective material, 1 horizontal stripe.
 - Contrasting trim detail.
 - Pockets: 1 upper left front, 1 lower right inside.
 - Material: 100% polyester mesh.
 - Colors: Hi-Viz Green and Orange.
 - Sizes: M, L, XL, 2X, 3X, 4X, 5X
- Item# **MAXSV22-3ZOM** (Orange)
Item# **MAXSV22-3ZGM** (Green)

MAX ECONOMY SURVEYOR SOLID TWILL, 1" PRISMATIC TAPE



- Features
- Closure: Zipper.
 - Prismatic gloss reflective material, 1 horizontal stripe.
 - Contrasting trim detail.
 - Pockets: Upper split pad/pencil, upper radio/phone, 2 each lower. Flap covered, 2 large deep open inside, 1 inside flashlight.
 - Material: 100% polyester solid twill front and back.
 - Colors: Hi-Viz Green and Orange
 - Size: Fits Medium - 5X
- Item# **MAXSV61-NZOS** (Orange)
Item# **MAXSV61-NZGS** (Green)

MAX NON RATED VESTS, 1" TAPE



- Features
- Front closure with hook and loop.
 - Colors: Hi-Viz Green and Orange
 - Material: 100% polyester mesh.
 - Durable elastic side straps.
 - Maintains brightness up to 25 washings.
 - Some models include 1" or 2" reflective green or silver stripes on front and back.
 - Does NOT meet the ANSI/ISEA requirements.
 - Sizes: S/XL, Universal.
- Item# **MAXSV01** (Orange)
Item# **MAXSVG1** (Green)

Did you know Abatix offers training courses? Located in our Santa Fe Springs, CA, Phoenix, AZ and Jacksonville, FL branches, Abatix Learning Centers offer a variety of certification classes regulated by both governmental and industry related groups, such as OSHA, EPA, Licensing groups (IICRC, IAQA, Maritime, and Construction), as well as product demonstrations and general industry informational sessions. Check our web site for details.

EXPERIENCE THE DIFFERENCE

Safety Wear - FR Vest

RADIANS ECONOMY CLASS 2 FIRE RETARDANT* (TWO-TONE TRIM)



Features

- Closure: Zipper.
- 2" Silver tape reflective material, 1 horizontal stripe.
- Pockets: 1 upper left front, 1 Lower right inside.
- Contrasting trim detail.
- Material: NFPA 701 (2004) treated fabric, 100% polyester mesh.
- Colors: Hi-Viz Green and Orange.
- Sizes: M, L, XL, 2X, 3X, 4X, 5X

Item# **RADSV225-2ZOM** (Orange)
Item# **RADSV225-2ZGM** (Green)

RADIANS ECONOMY CLASS 2 FIRE RETARDANT* (ZIPPER CLOSURE)



Features

- Closure: Zipper.
- 2" Silver tape reflective material, 1 horizontal stripe.
- Pockets: 1 upper left front, 1 lower right inside.
- Material: NFPA 701 (2004) treated fabric, 100% polyester mesh.
- Colors: Hi-Viz Green and Orange.
- Sizes: M, L, XL, 2X, 3X, 4X, 5X

Item# **RADSV25-2ZOM** (Orange)
Item# **RADSV25-2ZGM** (Green)

Safety Wear - T Shirts

RADIANS CLASS 2 HI-VIZ T-SHIRT Cool, Dry, All Day Comfort



Features

- 2" Heat transfer reflective tape, 1 horizontal stripe.
- Pockets: 1 upper left front.
- Materials: 100% wicking polyester mesh.
- Colors: Hi-Viz Green and Orange.
- Sizes: M, L, XL, 2X, 3X, 4X, 5X

Item# **RADST11-2POS** (Orange)
Item# **RADST11-2PGS** (Green)

Safety Wear - Sweatshirts

RADIANS CLASS 3 LONG SLEEVE HOODED SWEATSHIRT



Features

- Black elastic knit waistband and cuffs.
- 320gsm fleece material.
- 2" Silver reflective tape.
- Full front zipper closure.
- Two lower pouch pockets.
- Mesh lined hood with adjustable pull cords.
- Colors: Hi-Viz Orange and Green.
- Sizes: M, L, XL, 2X, 3X, 4X, 5X

Item# **RADSJ01-3ZOS** (Orange)
Item# **RADSJ01-3ZGS** (Green)

Safety Wear - Vests

RADIANS CLASS 2 HEAVY-DUTY SURVEYOR VEST



Features

- Woven fabric bias tape and heavy black webbing reinforcement.
- Pockets – Front: large radio/cell phone, split pencil/tablet, 2 ea. full with flap cover. Inside: 2 ea. lower full width, flap covered chest. Back: plan pocket (across the entire back).
- Silver 2" Class 2 glass bead reflective tape.
- Closure: Heavy metal chrome snaps. Grommets at neck for tool keepers/lanyards.

- 100% Polyester mesh and 100% polyester solid twill (pockets).
- Colors: Hi-Viz Green and Orange.

Back Plan Pocket:

- Two layer back pocket the width of the entire back of vest.
- Reinforced snap closure on both sides.
- Pocket opening the length of the side of the vest from bottom to arm pit.
- Sizes: S, M, L, XL, 2X, 3X, 4X, 5X

Item# **RADSV59-2ZOD** (Orange)
Item# **RADSV59-2ZGD** (Green)

RADIANS CLASS 2 SURVEYOR VEST



Features

- Closure: Zipper.
- 2" Silver tape reflective material, 1 horizontal stripe.
- Pockets: 1 split pad/pencil, 1 radio, 2 each lower flap covered, 2 each deep inside pockets.
- Materials: 100% polyester knit front, 100% polyester mesh back.
- Colors: Hi-Viz Green & Orange.
- Sizes: M, L, XL, 2X, 3X, 4X, 5X

Item# **RADSV70** (Orange)
Item# **RADSV7G** (Green)

Safety Wear - Neck Shade

RADIANS NECK SHADE



Features

- Contrasting Trim Detail.
- NFPA 701 (2004) FR treated 100% polyester mesh.
- Fits both cap style and full brim hard hats.
- Size: Universal

Item# **RADNSO** (Orange)
Item# **RADNSG** (Green)

* "Non-durable FR protection" is achieved by chemically treating a material that is not fire retardant by itself, but becomes self-extinguishing after the treatment.



Safety Wear - Ergonomics

PROFLEX® 1650 ECONOMY ELASTIC BACK SUPPORT
All elastic 7.5-inch body for extra firm support.



Applications:
Material Handling
Construction
Warehousing/Distribution
Maintenance
Freight/Baggage
Assembly/Fabrication
Landscaping/Grounds

- Features**
- 7.5" (19cm) Economical, all-elastic body.
 - 5" (12.7cm) Single strap closure.
 - Non-conductive polypropylene stays.
 - Rubber track webbing.
 - Stretchable bias binding with zig-zag stitching.
 - Adjustable, detachable suspenders.
 - Machine washable.

Item# ERG11091	XS	Item# ERG11095	XL
Item# ERG11092	S	Item# ERG11096	2XL
Item# ERG11093	M	Item# ERG11097	3XL
Item# ERG11094	L	Item# ERG11098	4XL

PROFLEX® 100 ECONOMY HI-VIS BACK SUPPORT
Hi-Vis orange panels keep workers conspicuous.



Applications:
Material Handling
Construction
Warehousing/Distribution
Maintenance
Freight/Baggage
Assembly/Fabrication,
Landscaping/Grounds.

- Features**
- Economical high visibility.
 - Adjustable, detachable suspenders.
 - Non-conductive polypropylene stays.
 - Stretchable bias binding with zig-zag stitching.
 - Hi-Vis Orange/Black.
 - Rubber track webbing.
 - Machine wash, cold; air dry.

Item# ERG11881	XS	Item# ERG11885	XL
Item# ERG11882	S	Item# ERG11886	2XL
Item# ERG11883	M	Item# ERG11887	3XL
Item# ERG11884	L	Item# ERG11888	4XL

PROFLEX® 300HL Rounded Cap Knee Pad
Short, hard cap is best for swiveling/pivoting.



- Features**
- Abrasion resistant rounded short hard cap.
 - 840D Nylon fabric cover / 12mm NBR foam padding.
 - Anti-odor treatment / Hook & loop closure.

Item# **ERG18301** (One Size)

Applications:
Construction
Masonry
Freight/Baggage
Flooring
Maintenance
Utilities
Carpentry

PROFLEX® 350 Gel Knee Pad
Gel comfort with slip resistant, puncture resistant soft cap.



- Features**
- 1680D Ballistic nylon outer shell for puncture resistance.
 - 12mm NBR Gel padding and 20mm EVA padding.
 - 420D Nylon & Hypalon rubber composite pad.
 - Slip-resistant durable nylon-rubber surface.
 - Adjustable, breathable neoprene stretch strap.
 - Hook & loop closure.

Item# **ERG18350** (One Size)

Applications:
Construction
Masonry
Freight/Baggage
Flooring
Maintenance
Utilities
Carpenter

PROFLEX® 400 (Universal) & 420 (w/Thumb Loop) WRIST WRAPS
Durable woven elastic for support and comfort. Hook & loop closure for exact tension and fit.



Universal

w/ Thumb Loop

- Features**
- Ambidextrous.
 - Available in black or tan.

Item# ERG72102	(Black) (Universal)
Item# ERG72103	(Tan) (Universal)
Item# ERG72222	(Black) (w/Thumb Loop) (S/M)
Item# ERG72224	(Black) (w/Thumb Loop) (L/XL)
Item# ERG72232	(Tan) (w/Thumb Loop) (S/M)
Item# ERG72234	(Tan) (w/Thumb Loop) (L/XL)

Applications:
Food Processing
Picking/Packing
Assembly/Fabrication

EXPERIENCE THE DIFFERENCE

Safety Wear - Cooling

CHILLOUT™ EVAPORATIVE COOLING PRODUCTS

Features

- Instant heat relief – Refreshing and energizing.
- Simply soak in water and use.
- Wipe away sweat and moisture.
- Wear around neck or partially over head.
- Comfortable design – Soft like fabric.
- Convenient One Size Fits All.
- Reusable, economical and effective.
- Can be laundered – Machine washable.
- UV resistant.
- High abrasion resistance.
- No linting.
- Environmentally friendly – Degradable.



ENVIROGUARD

Hard Hat Inserts
Item# **IESCO25HHI**



Towels – 33" x 13"
Item# **IESCO3313B** (Blue)
Item# **IESCO3313Y** (Hi-Vis Yellow)

Headbands
Item# **IESCO50HB**



Neckbands
Item# **IESCO50NB**

Chill-Its® 6200 PHASE CHANGE COOLING VEST Constant 58° keeps workers cooler, safer and more productive.



- Applications:**
- Pulp/Paper
 - Iron/Steel Fabrication
 - Hazmat
 - Fire/Rescue/EMT
 - Vulcanizing
 - Construction
 - Utilities
 - Refineries
 - Foundries

Features

- Maintains constant 58°F / 14°C.
- Cooling lifecycle lasts up to four hours.
- Comfortable cotton construction with hook & loop closure.
- Banox FR3® Fabric passes ASTM F1506; ATPV of 9.4 cal/cm² (HRC 2).
- Non-toxic, non carcinogenic, dielectric substance.

Item # **ERG6200-L/XL**

Chill-Its® 6675 CLASS 2 EVAPORATIVE COOLING VEST – Soak in cold water. Enjoy cooling relief, enhanced visibility.



- Applications:**
- Construction
 - Trades
 - Maintenance
 - Landscaping/Grounds
 - Assembly/Fabrication
 - Material Handling
 - Freight/Baggage
 - Warehousing/Distribution
 - Iron/Steel Fabrication

Features

- Activated, polymer-embedded fabric inside.
- Hi-Vis ANSI-certified polyester mesh outside.
- Water-repellent liner.
- Hook and loop closure and outside pocket.
- 3M™ Scotchlite™ Reflective Material, 2" Level 2 ANSI-compliant.

Item# **ERG6675-S/M**
Item# **ERG6675-L/XL**

Item# **ERG6675-2XL/3XL**
Item# **ERG6675-4XL/5XL**



Signs, Labels, Tags - Signs

ACCIDENT PREVENTION SAFETY SIGNS

Safety signs for the workplace are specified by OSHA 29 CFR 1910.145 and ANSI Z535 for design and application. Safety signs are to indicate potential, type, and degree of the hazard that may lead to accidental injury or property damage.

Materials

Adhesive Vinyl (VS)

For light-duty applications. The ideal choice for indoor and sheltered outdoor marking needs. Mounts to all curved areas such as pipes, poles and secondary containers.

- 4-mil thick surface printed matte surface.
- Permanent acrylic adhesive.
- Moisture-resistant.
- Service temperature range: -20°F to 140°F.
- Durability: 2 years outdoors.
- Square corners and scored backing for quick peel-off and application.

Plastic (VP)

Semi-flexible, economical and appropriate for medium duty use — ideal for indoor and sheltered outdoor environments.

- Ideal for flat surfaces with enough flex to mount on slightly curved areas.
- .055" Thick with good impact resistance and surface image with non-glare finish.
- Contains UV inhibitors.
- Service temperature range: -90°F to 168°F.
- Durability: 2 years outdoors.
- Rounded corners and 3/16" mounting holes.

Aluminum (VA)

Get the strength of metal, without the rust. Superior abrasion and chemical resistance for indoor and outdoor environments.

- Printed image on rigid .040" aluminum backing.
- Protected by 2-mil high-gloss UV polyester over-laminate film.
- Service temperature range: -20°F to 140°F.
- Withstands splashes and washdowns.
- Endures outdoor environmental conditions.
- Rounded corners and 3/16" mounting holes.

How to Order Signs



10" x 14"

MADM006 VP

Add the Material Code.

- Select Sign: **MADM006**
- Select Material Code: **Plastic – VP**
- Order Part Number: **MADM006VP**

ADMITTANCE & EXIT



7" x 10" MADM130
10" x 14" MADM006



7" x 10" MADM009
10" x 14" MADM008



7" x 10" MADMD05B
10" x 14" MADMD05



7" x 10" MADMD18B
10" x 14" MADMD18



7" x 10" MATR111
10" x 14" MADM064



7" x 10" MADM292
10" x 14" MADM076



7" x 10" MADMW04B
10" x 14" MADMW04



7" x 10" MADM313
10" x 14" MADM304



7" x 10" MADMC06B
10" x 14" MADMC06



7" x 10" MADM882
10" x 14" MADM893



7" x 10" MADMN12B
10" x 14" MADMN12



7" x 10" MADMN13B
10" x 14" MADMN13



7" x 10" MADMN30B
10" x 14" MADMN30



7" x 10" MADMN11B
10" x 14" MADMN11

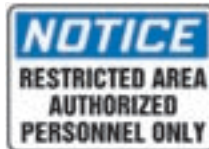

7" x 10" MADMN26B
10" x 14" MADMN26



7" x 10" MASE806
10" x 14" MASE807



7" x 10" MADM498
10" x 14" MADM499



10" x 14" MEXT14L



10" x 14" MEXT14R



7" x 10" MEXT06B
10" x 14" MEXT06



7" x 10" MEXT562
10" x 14" MEXT518



7" x 10" MEXT09B
10" x 14" MEXT09



7" x 10" MATR516
10" x 14" MATR521



7" x 10" MATR901
10" x 14" MATR900

CHEMICAL & HAZARDOUS MATERIALS



7" x 10" MCPGD19
10" x 14" MCHL174



7" x 10" MCHD35B
10" x 14" MCHD35



7" x 10" MCHD85B
10" x 14" MCHD85



7" x 10" MCHD81B
10" x 14" MCHD81



7" x 10" MCHD05B
10" x 14" MCHD05



7" x 10" MCHD09B
10" x 14" MCHD09

Continued on next page

Signs, Labels, Tags

EXPERIENCE THE DIFFERENCE

Signs, Labels, Tags - Signs



CHEMICAL & HAZARDOUS MATERIALS (Continued)

7" x 10" 10" x 14" MCHL186 MCHD08	7" x 10" 10" x 14" MCHD72B MCHD72	7" x 10" 10" x 14" MCHL127 MCHL125	7" x 10" 10" x 14" MCHD23B MCHD23	7" x 10" 10" x 14" MCPGD32 MCPGD12	7" x 10" 10" x 14" MCHL083 MCHL206
7" x 10" 10" x 14" MCPG025 MCHD17	7" x 10" 10" x 14" MCAW100 MCAW109	7" x 10" 10" x 14" MCHL077 MCHD71	7" x 10" 10" x 14" MWLD009 MWLD005	7" x 10" 10" x 14" MCHL317 MCHL309	7" x 10" 10" x 14" MCHL652 MCHL668
7" x 10" 10" x 14" MCPGC07B MCPGC07	7" x 10" 10" x 14" MCPGC22B MCPGC22	7" x 10" 10" x 14" MCHN12B MCHN12	7" x 10" 10" x 14" MCPG800 MCPG825	10" x 14" MCHL572	7" x 10" 10" x 14" MCHL517 MCHL516

CONFINED SPACE

7" x 10" 10" x 14" MCSP116 MCSP002	7" x 10" 10" x 14" MCSPD07B MCSPD07	7" x 10" 10" x 14" MCSP006 MCSP230	7" x 10" 10" x 14" MCSPD40B MCSPD40	7" x 10" 10" x 14" MCSP108 MCSP110	7" x 10" 10" x 14" MCSP122 MCSP026

CONFINED SPACE (Continued)

7" x 10" 10" x 14" MCSP012 MCSPD11	7" x 10" 10" x 14" MCSP007 MCSPD32	10" x 7" 14" x 10" MFYG417 MFYG22	7" x 10" 10" x 14" MFSD917 MFSD913	7" x 10" 10" x 14" MFSD506 MFSAD18	7" x 10" 10" x 14" MFSAD08B MFSAD08

LOCKOUT / TAGOUT

7" x 10" 10" x 14" MLKT106 MLKT015	7" x 10" 10" x 14" MLKT007 MLKT014	7" x 10" 10" x 14" MLKT279 MLKT280	7" x 10" 10" x 14" MLKT021 MLKT016	7" x 10" 10" x 14" MELC058 MELC059	7" x 10" 10" x 14" MELC017 MELC018

ELECTRICAL (Continued)

7" x 10" 10" x 14" MELCD09 MELCD06	7" x 10" 10" x 14" MELC132 MELCD05	7" x 10" 10" x 14" MELC135 MELCD02	7" x 10" 10" x 14" MELCD10 MELCD01	7" x 10" 10" x 14" MELC146 MELC054	7" x 10" 10" x 14" MELCC01 MELC625



Signs, Labels, Tags - Signs

EQUIPMENT, MACHINERY OPERATIONS



7" x 10" MCRT101
10" x 14" MADM014



7" x 10" MCPGD16B
10" x 14" MCPGD16



7" x 10" MEQM061
10" x 14" MEQD22



7" x 10" MEQM150
10" x 14" MEQM152



7" x 10" MEQC12B
10" x 14" MEQC12



7" x 10" MEQC03B
10" x 14" MEQC03

EQUIPMENT, MACHINERY OPERATIONS (Cont.)



7" x 10" MEQW01B
10" x 14" MEQW01



7" x 10" MEQC01B
10" x 14" MEQC01



7" x 10" MRST811
10" x 14" MRST805



7" x 10" MGNFN15B
10" x 14" MGNFN15



7" x 10" MHSK801
10" x 14" MHSK838



7" x 10" MHSK40B
10" x 14" MHSK40

HOUSEKEEPING / SAFETY INCENTIVE (Cont.)



7" x 10" MHSK939
10" x 14" MGNF43



7" x 10" MGNF984
10" x 14" MGNF35



7" x 10" MGNF980
10" x 14" MGNF38



7" x 10" MGNF956
10" x 14" MGNF940



7" x 10" MPPE011
10" x 14" MPPE010



7" x 10" MFPR104
10" x 14" MFPR105

PERSONAL PROTECTIVE EQUIPMENT (Cont.)



7" x 10" MPPE037B
10" x 14" MPPE037



7" x 10" MPPE219
10" x 14" MPPE218



7" x 10" MPPE436
10" x 14" MPPE57



7" x 10" MPPEC58B
10" x 14" MPPEC58



7" x 10" MPPEC70B
10" x 14" MPPEC70



7" x 10" MPPE854
10" x 14" MPPE09

SLIPS, TRIPS & FALLS



7" x 10" MSTF647
10" x 14" MSTF649



7" x 10" MSTF625
10" x 14" MCSPC34



7" x 10" MCSPC36B
10" x 14" MCSPC36



7" x 10" MCSPC38B
10" x 14" MCSPC38



7" x 10" MCSPC31B
10" x 14" MCSPC31



7" x 10" MCSPC33B
10" x 14" MCSPC33

SLIPS, TRIPS & FALLS (Cont.)



7" x 10" MSTF645
10" x 14" MCSPC37



7" x 10" MGNFN12B
10" x 14" MGNFN12



7" x 10" MSMKD06B
10" x 14" MSMKD06



7" x 10" MSMKD13B
10" x 14" MSMKD13



7" x 10" MSMK120B
10" x 14" MSMK050



7" x 10" MSMK850
10" x 14" MSMK849

SMOKING CONTROL (Cont.)



7" x 10" MSMK404
10" x 14" MSMK403



7" x 10" MSMK423
10" x 14" MSMK570



7" x 10" MSMK575
10" x 14" MSMK545



7" x 10" MSMK427
10" x 14" MSMK948

If you don't see the sign you need,
please call Abatix at
888-222-8499

Signs, Labels, Tags

EXPERIENCE THE DIFFERENCE

Signs, Labels, Tags - Labels



ACCIDENT PREVENTION LABELS

Printed on Adhesive Vinyl (VSP) in a package of 5, or Adhesive Dura-Vinyl (XVE) individually.

 LELC002VSP LELC002XVE	 LCSP266VSP LCSP266XVE	 LCSP280VSP LCSP280XVE	 LELC795VSP LELC795XVE	 LCHL285VSP LCHL285XVE	 LELC248VSP LELC248XVE	 LCHL293VSP LCHL293XVE
 LEQM279VSP LEQM279XVE	 LLKT286VSP LLKT286XVE	 LEQM273VSP LEQM273XVE	 LEQM123VSP LEQM123XVE	 LEQM269VSP LEQM269XVE	 LELC153VSP LELC153XVE	 LELC164VSP LELC164XVE
 LCHL675VSP LCHL675XVE	 LEQM780VSP LEQM780XVE	 LLKT611VSP LLKT611XVE	 LEQM782VSP LEQM782XVE	 LCB100VSP LCB100XVE	 LFXG440VSP LFXG440XVE	 LFS0509VSP LFS0509XVE

GHS PICTOGRAM LABELS

Pictogram labels comply with the Globally Harmonized System.

GHS pictograms identify the hazards associated with chemicals and warn users of the types of precautions that should be taken to minimize adverse effects that could result from exposure.

Labels are available in Adhesive Coated Paper (PS) and Adhesive-Poly Sheet (EV). Available by the roll in quantities of 250 or 500.

 Flame 1" x 1" LZH601 2" x 2" LZH611	 Flame Over Circle 1" x 1" LZH602 2" x 2" LZH612	 Exploding Bomb 1" x 1" LZH603 2" x 2" LZH613	 Corrosion 1" x 1" LZH604 2" x 2" LZH614	 Gas Cylinder 1" x 1" LZH605 2" x 2" LZH615
 Skull & Crossbones 1" x 1" LZH606 2" x 2" LZH616	 Exclamation Mark 1" x 1" LZH607 2" x 2" LZH617	 Environment 1" x 1" LZH608 2" x 2" LZH618	 Health Hazard 1" x 1" LZH609 2" x 2" LZH619	

Custom sizes and materials are available. Contact Abatix at 888-222-8499

GHS WALLET CARDS

Keep a visual reminder of GHS label and pictogram requirements close at hand for easy reference.

Plastic wallet card measures 3-3/8" x 2-1/8" and is double sided. One side of the wallet card shows a representation of the nine standard GHS pictograms, while the flip side shows a GHS label example.

Also available in Spanish, SHLKC241.



English Front
LKC241



Back

Continued on next page

Signs, Labels, Tags



Signs, Labels, Tags - Labels

RIGHT-TO-KNOW: SAFETY DATA SHEETS (HCS/GHS Format) POSTER

The 20" x 32" flexible plastic poster includes a summary of the information found in the GHS standardized 16-section SDS. OSHA is adopting this format as it works to align the Hazard Communication Standard (HCS) 29 CFR § 1910.1200 with the GHS.

Instructional sections cover product and company identification, hazards identification, composition, first aid measures, and much more.



Item# ZTP133

GHS POSTERS

Poster displays GHS label and pictogram guidelines in a visual, straightforward style. The 18" x 24" plastic laminate poster displays easy-to-understand information, separated into sections, on GHS labels and pictograms. Also available in Spanish, **SHZTP139**.



Item# ZTP139 English

Signs, Labels, Tags - Tags

SAFETY TAGS

Header style tags meet Occupational Safety and Health Administration requirements. Choose from a variety of common styles and legends that apply to a variety of situations. Tags are available in two materials: **PF-Cardstock** and **RP-Plastic**. Sold in pack of 25.

STANDARD SAFETY TAGS



MDT185CTP
MDT185PTP



MDT187CTP
MDT187PTP



MDT189CTP
MDT189PTP



MDT246CTP
MDT246PTP



MDT623CTP
MDT623PTP



STANDARD BACK

PF-Cardstock (CTP)

- 5-3/4" x 3-1/4" with 3/8" hole.
- Pliable, 10-mil poly based.
- Pulp-free, no wood-paper content.
- Waterproof, tear-resistant for light-duty use.

RP-Plastic (PTP)

- 5-3/4" x 3-1/4" with 3/8" hole, reinforced with metal grommet.
- 15-mil tear-resistant plastic.
- Weather- and chemical-resistant.

BLANK HEADER TAGS



Front MDT260CTP
MDT260PTP Back



Front MWGT205CTP
MWGT205PTP Back



Front MGT200CTP
MGT200PTP Back

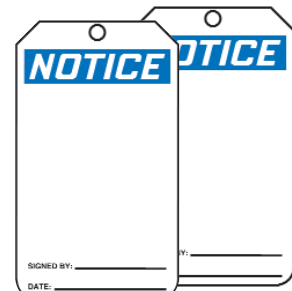

Front MNT101CTP
MNT101PTP Back

EXPERIENCE THE DIFFERENCE

Signs, Labels, Tags - Tags



SAFETY TAGS

LOCKOUT TAGS



MLT406CTP
MLT406PTP



MLT405CTP
MLT405PTP



MLT418CTP
MLT418PTP

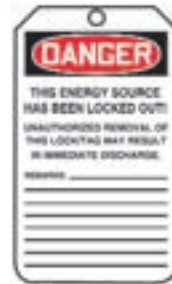

STD LOCKOUT BACK

PF-Cardstock (CTP)

- 5-3/4" x 3-1/4" with 3/8" hole.
- Pliable, 10-mil poly based.
- Pulp-free, no wood-paper content.
- Waterproof, tear-resistant for light-duty use.

RP-Plastic (PTP)

- 5-3/4" x 3-1/4" with 3/8" hole, reinforced with metal grommet.
- 15-mil tear-resistant plastic.
- Weather- and chemical-resistant.

FIRE EXTINGUISHER RECORDS

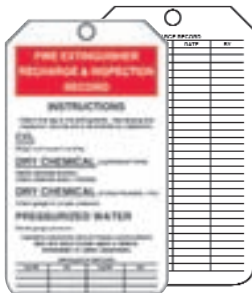

Front MGT208CTP
Back MGT208PTP



Front TRS218CTP
Back TRS218PTP

EQUIPMENT STATUS & INSPECTION TAGS



Front TSS102CTP
Back TSS102PTP



Front TSS101CTP
Back TSS101PTP



Front TSS103CTP
Back TSS103PTP

BARRICADE, CYLINDER & SERVICE STATUS



Front TAB105CTP
Back TAB105PTP

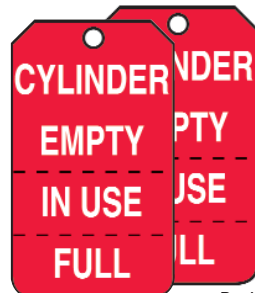

Front MGT206CTP (Perforated)
Back MGT206PTP (Perforated)



Front MGT219CTP
Back MGT219PTP



Front MGT217CTP
Back MGT217PTP



Front TRS243CTP
Back TRS243PTP

INSPECTION RECORDS

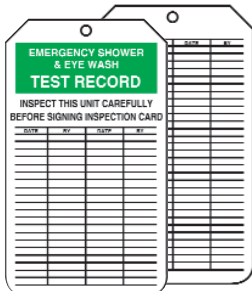

Front MGT207CTP
Back MGT207PTP



Front TRS307CTP
Back TRS307PTP



Front TRS315CTP
Back TRS315PTP

How to Order Tags

Choose the part number that includes the desired material code.

- Select Tag: **MDT161**
- Select Material Code: RP-Plastic – **PTP**
- Order Part Number: **MDT161PTP**

Material	Material Code	Size
PF-Cardstock	CTP	5-3/4" x 3-1/4"
RP-Plastic	PTP	5-3/4" x 3-1/4"

Additional Styles Available.



Spill Control - Absorbents

OIL ONLY PADS AND ROLLS



Oil Only Pads and Rolls

- CEP pure meltblown polypropylene fibers are the most cost-effective adsorption technology today.
- Fast-wicking fibers absorb up to 25x their weight in hydrocarbon.
- These durable, pads and rolls absorb petroleum based liquids, but never water.
- Ideal when you have to clean up oily spills or drips.
- Great for when you don't need the extra absorbency or expense of a universal absorbent.

Item#	CEVP100	Pads (Heavy-Weight), 15" x 17", 100/cs
Item#	CEVEP100	Pads (Medium-Weight), 15" x 17", 100/cs
Item#	CEVP200	Pads (Single-Weight), 15" x 17", 200/cs
Item#	CEVR144	Roll (Heavy-Weight), 30" x 150', 1/cs
Item#	CEVER144	Roll (Medium-Weight), 30" x 150', 1/cs

OIL ONLY BOOMS, PILLOWS AND SOCKS

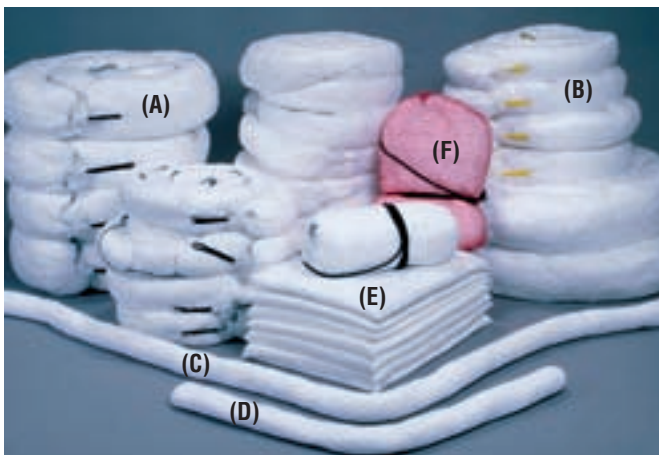

Oil Only Sorbent Booms (Polypropylene)

- Provides containment and max. absorption while repelling water.
- Absorbs oil on land or water even when raining.
- Will not sink even if the boom is saturated.
- Comprised of anti-shed or non-lint netting.
- Overlapping clips for deployment in any length.
- Embedded rope for easy deployment and retrieval in water.
- Ideal uses include wastewater troughs, loading docks, ponds, rivers, and oceans to absorb oily spills.

Item#	CEVB810	8" x 10', 4/cs (A)
Item#	CEVB510	5" x 10', 4/cs (B)

Oil Only Polypropylene Socks

- Socks remove oil from troughs, vats, catch basins and sumps.
- Can be used indoors or out and will not absorb water.
- Absorbs oil from water around leaking machines exposed to rain and various other oil/water separation applications.
- Polypropylene socks are wringable for reclaiming liquids.
- Very high absorbency rate.

Item#	CEVPS12	3" x 48", 12/cs (C)
Item#	CEVPS10	3" x 10', 4/cs (D)

Oil Only Sorbent Pillows and Sack Pillows

- Pillows are ideal for oil spill control, spill containment, oil spill clean up and skimming oil from water.
- Works great for catch basins, sumps, leaking machinery, etc.
- Heavy-duty polypropylene cover resists tearing.
- Use on land or water.

Item#	CEVPIL10	Pillow, 3" x 18" x 24", 10/cs (E)
Item#	CEVSAKPIL10	Sack Pillow w/strap, 14" x 25", 10/cs (F)

OIL ONLY BONDED PADS AND ROLLS



Oil Only Bonded Sorbent Pads and Rolls

- Ideal for wiping applications where increased tensile strength is necessary.
- The sonic bonding process creates a stronger, more durable fiber without affecting absorption.
- CEP pure meltblown polypropylene fibers are the most cost-effective adsorption technology today.
- Fast-wicking fibers absorb up to 25x their weight in hydrocarbon.
- These durable, bonded pads and rolls absorb petroleum based liquids, but never water.
- Ideal when you have to clean up oily spills or drips.
- Great for when you don't need the extra absorbency or expense of a universal absorbent.

Item#	CEVBP100	Pads (Heavy-Weight), 15" x 17", 100/cs
Item#	CEVBEP100	Pads (Medium-Weight), 15" x 17", 100/cs
Item#	CEVBP200	Pads (Single-Weight), 15" x 17", 200/cs
Item#	CEVBR144	Roll (Heavy-Weight), 30" x 150', 1/cs
Item#	CEVBER144	Roll (Medium-Weight), 30" x 150', 1/cs

EXPERIENCE THE DIFFERENCE

Spill Control - Absorbents

OIL ONLY PERFORATED SORBENT PADS AND ROLLS



Oil Only Fine Fiber Bonded Sorbent Pads and Rolls

- Fine fiber bonded pads and rolls are the strongest absorbents.
- Two layers of fine fiber polypropylene are ultrasonically bonded around a high-loft meltblown core.
- Perforated, allowing you to take precisely the right amount of material to do the job.
- Non-toxic.
- Dimpled for faster adsorption. Absorbs 24 gallons per case.
- Ideal for heavy spills.
- Low-linting and maximum durability.
- Control oversprays and spills with excellent absorbency.
- Keep floors clean, dry, and safe.

Item# **CEVQ100P** Pads (Heavy-Weight), 15" x 17", 100/cs
 Item# **CEVQ150P** Rolls (Heavy-Weight), 30" x 150', 1/cs

UNIVERSAL ALL PURPOSE SORBENTS



Universal General Purpose Sorbent Socks and Pillows

- Gray color hides grime.
- Absorbs oils, water, coolants and solvents
- Perfect moldable application for continuous maintenance leaks
- The recycled fiber fillers are BTU rich for multiple disposal options
- No messy cleanup - simply throw away the old product and lay down a fresh one.

Item# **CEVGS4** Socks, 3" x 4", 40/cs
 Item# **CEVGS6** Socks, 3" x 6", 25/cs
 Item# **CEVGS8** Socks, 3" x 8", 20/cs
 Item# **CEVGS10** Socks, 3" x 10", 15/cs
 Item# **CEVGPIL16** Pillows, 2" x 11" x 13", 16/cs



UNIVERSAL ALL PURPOSE SORBENTS

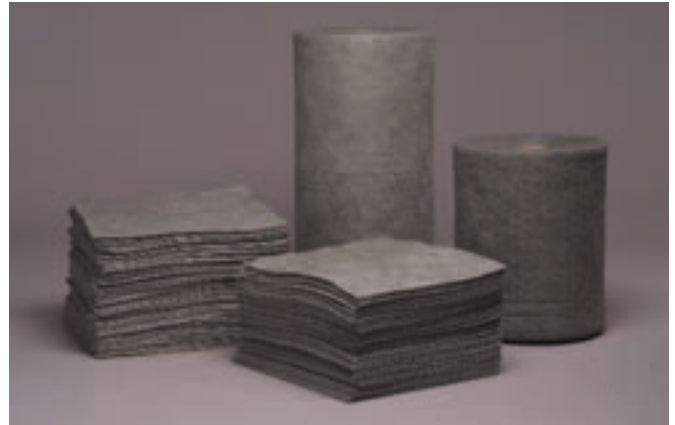

Universal Gray Bonded Sorbent Pads and Rolls

- Control oversprays and spills with excellent absorbency.
- Keep floors clean, dry and safe.
- Grunge hiding grey for universal applications.
- Pads and rolls have ultrasonic weld points to keep them fully intact.
- Pads and rolls are made of meltblown polypropylene fibers.
- Dimpled for added strength.

Item# **CEVUQ100** Pads (Heavy-Weight), 15" x 17", 100/cs
 Item# **CEVUQ150** Rolls (Heavy-Weight), 30" x 150', 1/cs

UNIVERSAL HAZ MAT SORBENTS



Universal Haz Mat Sorbent Pads and Rolls

- Ideal for wiping up smaller chemical spills.
- These pads and rolls will absorb all liquids from water based fluids to aggressive acids.
- Bonded for tensile strength and absorb up to 25x their weight in all liquids. Quick and easy to apply.

Item# **CEVUP100** Pads (Heavy-Weight), 15" x 17", 100/cs
 Item# **CEVUR150** Rolls (Heavy-Weight), 30" x 150', 1/cs
 Item# **CEVUSR150** Split Rolls (Heavy-Weight), 15" x 150", 2/cs

Universal Haz Mat Sorbent Socks and Pillows

- Absolute necessity for any haz mat spill or spill contingency plan.
- Absorbs up to 25x their weight in fluid.

Item# **CEVHAZSOC12** Socks, 3" x 48", 12/cs
 Item# **CEVHAZSOC10** Socks, 3" x 10", 4/cs
 Item# **CEVHAZPIL10** Pillows, 3" x 18" x 24", 10/cs



Spill Control - Granular Absorbents

CHEETAH SORB ABSORBENT



Give your oil absorbent "Cheetah Power!" The first new oil absorbent that is dust-free, highly absorbent, incinerable and priced like floor dry! Cheetah Sorb even looks like floor absorbent, without the harmful silica. Lower your handling costs and get the power of the "Cheetah" at kitty litter prices!

Item# **CEVTS20** 20-lb. Bag

SPHAGNUM PEAT MOSS ABSORBENTS



The CEP organic heat treated peat moss is a hydrophobic, biodegradable granular that absorbs 15 times its weight in hydrocarbons. It contains less than 5% moisture, making this one of the best absorbents on fine sheens or concrete stains. Peat Moss is non-toxic and all natural.

- Item# **CEVPEAT2-P** Peat Sorb, 3 cu. ft./bag
- Item# **CEVPEATSOCK4** Peat Sock, 4" x 4', 20/cs
- Item# **CEVPEATSOCK8** Peat Sock, 4" x 8', 10/cs
- Item# **CEVPEATSOCK10** Peat Sock, 2" x 10', 20/cs
- Item# **CEVPEATPAD10** Peat Pad, 18" x 18", 10/cs

VOLCANIC ASH ANTI-SLIP SAFETY ABSORBENT



Volcanic ash rock creates a natural surface to plant floors with the highest anti-slip or non-skid characteristics of all sorbents. The product is also ideal for vapor suppression.

Item# **CEVVASH25** 25-lb. Bag

**FLOOR DRY
CLAY BASED ABSORBENT
(Diatomaceous Earth)**



This traditional clay based absorbent is still very cost effective and is ideally suited for industrial plant every day spills. The granular mesh size creates a safe non-slip work area.

Item# **CEVFLAB50** 50-lb. Bag

KENAF ORGANIC / BIODEGRADABLE ABSORBENT



The Kenaf Bio-Sorb and Organic granular absorbents have indigenous oil eating microbes that solve many long-term spill disposal situations. These products are all natural, non-toxic and completely biodegradable.

- Item# **CEVKENAF2** Bio-Sorb, 2 cu. ft./bag
- Item# **CEVKENAF3** Organic, 2 cu. ft./bag

VERMICULITE ABSORBENT



Vermiculite is clean to handle, non-abrasive reflective, rot-proof odorless, moldable and non-irritant. It is light, clean, and easily poured around irregular shaped objects; and it provides an excellent cushion against impact shock. Ideal for solidification, packaging and incineration.

Item# **CEVVERM4** 4 cu. ft./bag

Spill Control

Spill Control - Spill Kits

Spill kits are perfect for any and all disaster preparedness situations. They contain the finest quality products for oil only or universal spill control and are fully customizable.



5-Gallon Spill Kit

Contents:

- 5-Gallon plastic pail with lid
- 10 Sorbent pads
- 2 Sorbent socks
- 1 Pair of goggles
- 1 Pair of gloves
- 1 Disposable bag.

- Item# **CEVSK5** 5-Gal., (Oil Only)
 Item# **CEVHAZSK5** 5-Gal., (Universal Hazmat Aggressive)
 Item# **CEVGPSK5** 5-Gal., (Universal General Purpose)



55-Gallon Spill Kit

Contents:

- 55-Gallon poly drum with lid
- 100 Sorbent pads (CEVGPSK55 contains 50 pads)
- 2 Booms (CEVSK55 and CEVHAZSK55 only)
- 5 Sorbent pillows
- 1 Pair of goggles
- 1 Pair of gloves
- 1 Disposable bag.

- Item# **CEVSK55** 55-Gal., (Oil Only)
 Item# **CEVHAZSK55** 55-Gal., (Universal Hazmat Aggressive)
 Item# **CEVGPSK55** 55-Gal., (Universal General Purpose)



20-Gallon Spill Kit

Contents:

- 20-Gallon lab pack with lid
- 50 Sorbent pads
- CEVGPSK20 contains 25 sorbent pads
- 4 Sorbent socks
- 2 Sorbent pillows
- 1 Pair of goggles
- 1 Pair of gloves
- 1 Disposable bag.

- Item# **CEVSK20** 20-Gal., (Oil Only)
 Item# **CEVHAZSK20** 20-Gal., (Universal Hazmat Aggressive)
 Item# **CEVGPSK20** 20-Gal., (Universal General Purpose)



95-Gallon Spill Kit

Contents:

- 95-Gallon overpack with lid
- 100 Sorbent pads
- 4 Booms
- 10 Sorbent pillows
- 1 Pair of goggles
- 1 Pair of gloves
- 1 Disposable bag.

- Item# **CEVSK95** 95-Gal., (Oil Only)
 Item# **CEVHAZSK95** 95-Gal., (Universal Hazmat Aggressive)
 Item# **CEVGPSK95** 95-Gal., (Universal General Purpose)



30-Gallon Spill Kit

Contents:

- 30-Gallon poly drum with lid
- 50 Sorbent pads
- 12 Sorbent socks
- CEVGPSK30 contains 6 sorbent socks
- 4 Sorbent pillows
- 1 Pair of goggles
- 1 Pair of gloves
- 1 Disposable bag.

- Item# **CEVSK30** 30-Gal., (Oil Only)
 Item# **CEVHAZSK30** 30-Gal., (Universal Hazmat Aggressive)
 Item# **CEVGPSK30** 30-Gal., (Universal General Purpose)

Looking for or considering a vending solution? With Abatix Supply Advantage Program – A.S.A.P. vending solutions you could reduce supply costs and improve productivity. Check out our web site to find out more about our A.S.A.P. vending solutions.



Spill Control - Containment Berms

ULTRA-CONTAINMENT BERMS®

Ultra-Containment Berms provide versatile spill containment for vehicles, drums, IBCs, totes, frac tanks and other containers and vessels that would otherwise not have a good containment option.

COLLAPSIBLE WALL MODEL – Economical design offers cost savings and secure containment.



- The Collapsible Wall Model Containment Berm features rugged PVC sidewall assemblies for sidewall support. Simply swivel the “feet” of the PVC supports to lower or raise the sidewalls in just seconds!
- Meets SPCC & EPA Container Storage Regulations 40 CFR 264.175.

Item#	Dimensions	Weight	Containment Capacity
UT18400	10' x 10' x 1'	70 lbs.	748 gallons

RAPID RISE MODEL – Sidewalls stay lowered and out of the way until they are needed.



- Sidewalls remain down during normal operations, loading and unloading. Vehicles and equipment can drive in and out from any angle, with no sidewall set-up or take-down required.
- In the case of a spill, the foam ring around the top perimeter of the Containment Berm rises with the level of spilled liquid.
- Standard material of construction is Copolymer 2000™.
- Meets SPCC & EPA Container Storage Regulation 40 CFR 264.175.

Item#	Dimensions	Weight	Containment Capacity
UT18432	10' x 10' x 1'	63 lbs.	748 gallons
UT18437	12' x 26' x 1'	149 lbs.	2,333 gallons

ULTIMATE MODEL – Unique, “Living Hinge” design allows hands-free Drive In/Drive Out – no need to manually raise or lower the endwalls. Convenient and affordable.



- Entry and exit walls are supported every 12" with a patented “living hinge.”
- Once a vehicle has entered or exited, the walls automatically spring back to their vertical position.
- Both long sidewalls are held upright by PVC sidewall assemblies. Simply swivel the feet to lower the sidewalls for storage or transport to another location.
- Meets SPCC & EPA Container Storage Regulation 40 CFR 264.175.

Item#	Dimensions	Weight	Containment Capacity
UT18505	12' x 60' x 1'	309 lbs.	5,385 gallons
UT18506	15' x 50' x 1'	326 lbs.	5,610 gallons
UT18507	15' x 66' x 1'	405 lbs.	7,405 gallons

EXPERIENCE THE DIFFERENCE

Spill Control - Drain Seals

ULTRA-DRAIN SEALS® – Stops spills from going down the drain.



- Reinforcing mesh is “sandwiched” between layers of polyurethane — increases durability and resistance to tearing.
- Unique, urethane construction allows the pad to deform and seal off most drains — temporarily “seals” to any smooth surface.
- A valuable addition to any emergency response plan, spill kit, SPCC or stormwater management program.
- Unlike some alternative products, BOTH sides will quickly seal drains — there is no specified “top” or “bottom.”

Item#	Dimensions	Weight
UTI2130	36" x 36" x 3/8"	20 lbs.
UTI2131	42" x 42" x 3/8"	23 lbs.
UTI2132	48" x 48" x 3/8"	36 lbs.

ULTRA-DRAIN SEAL PLUS® – Protects drains and can be left outside long-term.



- Urethane bottom layer (same as Ultra-Drain Seal) keeps spills from entering drains.
- Rugged, reinforced PVC top layer (yellow) provides protection from extended UV exposure and vehicular traffic.
- Excellent for use in parking areas, loading docks and other areas where drains may be driven over.

Item#	Dimensions	Weight
UTI2160	36" x 36"	23 lbs.
UTI2161	42" x 42"	27 lbs.
UTI2162	48" x 48"	43 lbs.

ULTRA-DRAIN SEAL® CLEAR MODEL– Allows responders to see spills are being stopped.



- Clear material provides unobstructed view of covered drains - enables responders to make sure a complete seal is made.
- No more guesswork about Drain Seal effectiveness - quickly see if spills are entering the drain through cracks in the surface, imperfections in the grating or other irregularities that can break the seal.
- Reinforcing mesh is “sandwiched” between layers of polyurethane — increases durability and resistance to tearing.
- Unique, urethane construction allows the pad to deform and seal off most drains — temporarily “seals” to any smooth surface.
- Helps comply with SPCC and NPDES

Item#	Dimensions	Weight
UTI2202	36" x 36"	20 lbs.
UTI2203	42" x 42"	23 lbs.
UTI2204	48" x 48"	36 lbs.

Spill Control - Hard Tops

ULTRA-HARD TOP P1 PLUS® – The only 1-drum, lockable outdoor containment unit available.

- Convenient “roll-top” cover slides up and out of the way — allows quick access to drum pumps and funnels.
- 100% Polyethylene construction will not rust or corrode.
- Safe Handling — can be moved by forklift under the “shoulder” area or wheeled w/optional dolly.
- Meets SPCC and EPA Container Storage Regulation 40 CFR 264.175.
- Helps meet Stormwater Management Regulations — NPDES, 40 CFR 122.26 (1999).
- Dimensions: 36" x 36" x 66"
- Weight: Top - 36 lbs. / Bottom - 26 lbs.
- Load Capacity: 800 lbs.
- Containment Capacity: 64 gallons.

Item# **UT19640** (no drain)
Item# **UT19641** (with drain)



ULTRA-HARD TOP P2 PLUS® – Store hazardous drums safely outdoors with pumps and funnels in place.

- Tall 23-3/4" head space easily accommodates rotary drum pumps and large conical funnels.
- Low profile (8-3/4") containment pallet positions drum top funnels at a safe, convenient level to pour hazardous wastes.
- 100% Polyethylene construction will not rust or corrode.
- Ultra-Hard Top P2 Plus is lockable with a standard padlock, and can be safely lifted by forklift with drums in place.
- “Swing out” lower doors provide full access to drums for loading and unloading — optional ramp features a non-slip surface.
- Meets SPCC, EPA Container Storage Regulation 40 CFR 264.175 and UFC Spill Containment Regulations.
- Helps meet Stormwater Management Regulations — NPDES, 40 CFR 122.26 (1999).
- Dimensions: 67-1/4" x 41-1/4" x 74"
- Weight: 260 lbs.
- Uniformly Distributed Load: 4,500 lbs.
- Containment Capacity: 66 gallons.

Item# **UT19612** (no drain)
Item# **UT19613** (with drain)



ULTRA-HARD TOP P4 PLUS® – Safely store 4 drums outdoors

- Unique “dual closure” offers significant ergonomic and convenience benefits — drums are easily accessed from either side.
- Roll-top covers can be easily lifted from waist height to access drum tops — no need to reach near ground level.
- Low profile (8 3/4") containment pallet positions drum tops at a safe, convenient level to pour wastes into funnels or to use drum pumps.
- Forkliftable, lockable, all-polyethylene construction will not rust or corrode.
- Helps meet Stormwater Management Regulations — NPDES, 40 CFR 122.26 (1999).
- Meets SPCC and EPA Container Storage Regulation 40 CFR 264.175.
- Dimensions: 64-1/2" x 62" x 79"
- Weight: 440 lbs.
- Uniformly Distributed Load: 9,000 lbs.
- Containment Capacity: 75 gallons.

Item# **UT19636** (no drain)
Item# **UT19637** (with drain)



Spill Control - IBC Spill Pallets

ULTRA-IBC SPILL PALLET PLUS® – Economical and portable containment for IBCs.

- 28" Poverall height.
- Excellent chemical resistance and will not rust or corrode.
- Forkliftable — allows convenient positioning to desired locations.
- Low-cost design with value-added features and benefits.
- Large 52" x 52" deck allows safe and convenient placement of IBC tanks.
- Small footprint — 62" x 62" unit requires minimal floor space.
- Available with optional Bucket Shelf — catches leaks or spills during dispensing.
- 360-Gallon sump capacity meets SPCC and EPA Container Storage Regulations.
- Dimensions: 62" x 62" x 28"
- Weight: 320 lbs.
- Uniformly Distributed Load: 8,500 lbs.
- Containment Capacity: 360 gallons.

Item# **UT11157** (no drain)
Item# **UT11158** (with drain)



Don't see what you are looking for? Ask your Abatix Sales Representative. Abatix carries tens of thousands of products. We will make sure you get what you need, when you need it, where you need it.

EXPERIENCE THE DIFFERENCE

Spill Control - Overpacks

ULTRA-OVERPACKS® – Versatile, offering the highest UN and DOT certifications available.

- High-density polyethylene construction offers excellent chemical resistance, including acids, caustics and corrosives.
- Convenient, “no-tools required” closures are perfect for clean-up and spill response activities.
- Nestable design and low tare weight allow convenient storage and reduced transportation costs.



Overpack Plus 95

- Top Outside Diameter: 32-1/4"
- Bottom Outside Diameter: 25-1/2"
- Outside Height: 43-1/4"
- Weight: 48 lbs.

Item# **UT10580** (95 Gallon)

Overpack Plus 65

- Top Outside Diameter: 29"
- Bottom Outside Diameter: 21"
- Outside Height: 36-1/4"
- Weight: 40 lbs.

Item# **UT10582** (65 Gallon)

Spill Control - Spill Berm

ULTRA-SPILL BERM® – Temporary berm seals off spills from the environment, nearby drains and doorways.



ULTRA-RECYCLED OVERPACK 95® – Eco-Friendly overpack uses recycled content.

- Highest performance overpack on the market with the added benefit of eco-friendly, recycled content.
- Easy-to-close screw top lid.
- Black color helps hide dirt and grime.
- Complies with UN Packaging Group 2 (Y-Rating) and certified for use as DOT Salvage Drums, 49 CFR 173.3 (c).
- Outside Dimensions: 32-1/4" dia. x 41-1/2" H
- Weight: 48 lbs.

Item# **UT10570** (95 Gallon)



ULTRA-WHEELED OVERPACK 95® – Built-in wheels help get overpack to spills quickly and easily.

- Highest performance of any 95-gallon overpack on the market.
- Built-in wheels eliminate the need for a separate dolly or other transport.
- Easy-to-close screw top lid.
- Ideal for mobile spill kits.
- Complies with UN Packaging Group 1 (X-Rating) and certified for use as DOT Salvage Drums, 49 CFR 173.3 (c).
- Outside Dimensions: 35-1/2" dia. x 48-1/2" H
- Weight: 58 lbs.

Item# **UT10584** (95 Gallon)



- Standard 10-foot sections can be cut to various lengths to meet custom needs.
- Unique, urethane material “weeps” into small cracks and crevices to seal off liquid flow.
- Spill Berm is non-absorbing and is easily cleaned for repeated use.
- Applications include: Spill response, Temporary secondary containment, and Sealing off of doorways during washdown operations.
- Flexible Ultra-Spill Berm will bend and turn to form almost any shape while temporarily “bonding” to any smooth surface.
- Helps comply with NPDES and SPCC.
- Dimensions: 10" x 4" x 2-1/4"
- Weight: 31 lbs.

Item# **UT12100**



Spill Control - Spill Deck

ULTRA-SPILL DECKS® – Low profile, modular spill decks allow you to design and create a containment system that meets your specific needs.

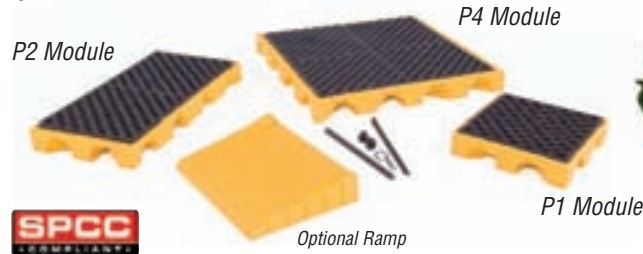

ULTRA-SPILL DECK BLADDER SYSTEMS® – Hidden containment bladder automatically unfurls to capture large spills or drum leaks.



Modules are easily connected together with bulkhead fittings to allow a virtually unlimited number of customized configurations.

- Polyethylene construction meets a wide range of chemical compatibility needs.
- Low profile – safe and convenient loading/unloading of drums.
- Applications include hazardous waste collection, storage of virgin chemicals, drum dispensing and battery storage.
- Optional Loading Ramps.
- Meets SPCC, EPA Container Storage Regulation 40 CFR 264.175 and UFC Spill Containment Regulations.
- Decks hold up to 1,500 lbs. per drum (uniformly distributed load).

- Polyethylene bladder is housed inside the Bladder Attachment (sold separately). Connect the Bladder Attachment to the Spill Deck in seconds — no tools required!
- Low profile – safe and convenient loading/unloading of drums.
- Meets SPCC, EPA Container Storage Regulation 40 CFR 264.175 and UFC Spill Containment Regulations.

Item# **UTI1321** (P1 Module) (25-7/8" x 25-7/8" x 5-3/4", 23 lbs.)
 Item# **UTI1086** (P2 Module) (52" x 25-7/8" x 5-3/4", 40 lbs.)
 Item# **UTI1072** (P4 Module) (52" x 52" x 5-3/4", 70 lbs.)

Item# **UTI1320** (P1 System) (25-7/8" x 30-1/2" x 5-3/4", 27 lbs., 77 gal. capacity)
 Item# **UTI2329** (P2 System) (52" x 30-1/2" x 5-3/4", 44 lbs., 88 gal. capacity)
 Item# **UTI2330** (P4 System) (52" x 56-5/8" x 5-3/4", 66 lbs., 110 gal. capacity)

Spill Control - Spill Pallet

ULTRA-SPILL PALLETS® – Spill pallets are built for heavy loads and convenient handling.



ULTRA-SPILL PALLET ECONOMY MODELS®



- Bright, safety yellow sidewalls are translucent.
- 100% polyethylene construction.
- Meets SPCC, EPA Container Storage Regulation 40 CFR 264.175 and UFC Spill Containment Regulations.

- Available in 2-drum and 4-drum configurations.
- Applications for the all-polyethylene units include satellite waste collection and storage of virgin chemicals.
- Black color helps hide dirt and grime.
- Meets SPCC, EPA Container Storage Regulation 40 CFR 264.175 and UFC Spill Containment Regulations.

Spill Pallet P2
 • 53" x 29" x 16-1/2" / 63 lbs.
 • Uniformly Distributed Load: 3,000 lbs.
 • Containment Capacity: 66 gal.
 Item# **UTI1010** (no drain)
 Item# **UTI1011** (with drain)

Spill Pallet P4
 • 53" x 53" x 11-3/4" / 90 lbs.
 • Uniformly Distributed Load: 6,000 lbs.
 • Containment Capacity: 66 gal.
 Item# **UTI1000** (no drain)
 Item# **UTI1001** (with drain)

Spill Pallet P2-1500
 • 53" x 29" x 16-1/2" / 63 lbs.
 • Uniformly Distributed Load: 1,500 lbs.
 • Containment Capacity: 66 gal.
 Item# **UTI2504** (no drain)
 Item# **UTI2505** (with drain)

Spill Pallet P4-3000
 • 53" x 53" x 11-3/4" / 85 lbs.
 • Uniformly Distributed Load: 3,000 lbs.
 • Containment Capacity: 66 gal.
 Item# **UTI1112** (no drain)
 Item# **UTI1113** (with drain)

EXPERIENCE THE DIFFERENCE

Spill Control - Utility Trays

ULTRA-UTILITY TRAYS® – Keep messy drips and spills off warehouse and factory floors.

- Heavy-duty polyethylene construction — will not rust or corrode.
- Ribbed bottom keeps cans, pails and other containers elevated above small spills or leaks.
- Use for storage/spill containment for leaky machine parts or equipment.
- Place under trucks or other large vehicles.
- Nestable for easy storage when not in use.
- Available in six sizes.



Item#	Inside Dimensions	Capacity	Weight
UTI1031	12" x 48" x 4-3/4"	12 gal.	8 lbs.
UTI1032	24" x 48" x 4-3/4"	24 gal.	13 lbs.
UTI1033	30" x 48" x 4-3/4"	30 gal.	16 lbs.
UTI1034	24" x 36" x 4-3/4"	18 gal.	10 lbs.
UTI1035	36" x 36" x 4-3/4"	27 gal.	10 lbs.
UTI1036	40" x 48" x 3-1/2"	30 gal.	18 lbs.

Spill Control - Stormwater Compliance

ULTRA-DEWATERING BAG® – Contain sediment and oil pumped out during dewatering operations.



Oil & Sediment Model

- Detains both oil and sediment, offering a combination of benefits not available in alternative dewatering bags.
- Standard and custom sizes available.
- Accommodates up to 4" discharge hose.
- Helps comply with NPDES, 40 CFR 122.26 (1999) when used as Best Management Practice in Storm Water Pollution Prevention Plans.

Item#	Dimensions	Capacity
UTI9729-O/S	3' x 4'	6 cu. ft.
UTI9724-O/S	6' x 6'	18 cu. ft.
UTI9725-O/S	10' x 15'	150 cu. ft.
UTI9727-O/S	15' x 15'	225 cu. ft.

ULTRA-DRAIN GUARD® – Keeps sediment and other pollutants from entering the water system.



Oil & Sediment Model

- Exceeds 80% sediment removal efficiency.
- Helps comply with NPDES, 40 CFR 122.26 (1999) when used as Best Management Practice in Storm Water Pollution Prevention Plans.
- Designed for practical use in:
 - Industrial Facilities - keep oil and other contaminants from entering storm drains.
 - Construction Sites - capture eroded soil and wind-blown debris.
 - Parking Lots, "Drive-Up" Retail Facilities - selected geotextiles collect oil, fuel and other contaminants that drip from cars.
- Removes up to .87 gallons of hydrocarbons as well as dirt, sand and other contaminants.
- Dimensions: 48" x 36"
- Weight per unit: 1 lb.

Item# **UTI9217** (1-Pack)
Item# **UTI9218** (10-Pack)

Spray Paint - General Purpose

INDUSTRIAL CHOICE ENAMEL AEROSOL (1600 System)

Multi-purpose spray paint developed for everyday industrial maintenance applications.

- 2 Times the coverage of competitive brands – paint more area faster using fewer cans!
- New 360° Any Angle Spray allows you to spray in any direction.
- New comfort tip reduces finger fatigue.
- Dries to touch in only 12 minutes.
- High solids formula delivers complete, even coverage.
- Protects against chipping, cracking, peeling.
- Can be used on surfaces that reach temperatures up to 200°F.
- USDA acceptable.*

- Item# **RUS1610830** (Crystal Clear)
- Item# **RUS1614830** (Dull Aluminum)
- Item# **RUS1622830** (Regal Blue)
- Item# **RUS1624830** (Safety Blue)
- Item# **RUS1626830** (True Blue)
- Item# **RUS1632830** (Fluorescent Green)
- Item# **RUS1633830** (Safety Green)
- Item# **RUS1638830** (Hunter Green)
- Item# **RUS1642830** (Fluorescent Yellow)
- Item# **RUS1643830** (School Bus Yellow)
- Item# **RUS1644830** (Safety Yellow)
- Item# **RUS1653830** (Safety Orange)
- Item# **RUS1654830** (Fluorescent Orange)
- Item# **RUS1655830** (Fluorescent Red-Orange)
- Item# **RUS1659830** (Fluorescent Pink)
- Item# **RUS1660830** (Safety Red)
- Item# **RUS1664830** (Cherry Red)
- Item# **RUS1666830** (Banner Red)
- Item# **RUS1667830** (Red Primer)
- Item# **RUS1670830** (Safety Purple)
- Item# **RUS1671830** (Beige)
- Item# **RUS1672830** (Almond)
- Item# **RUS1674830** (Leather Brown)
- Item# **RUS1676830** (Ultra-Flat Black)
- Item# **RUS1678830** (Semi-Flat Black)
- Item# **RUS1679830** (Glossy Black)
- Item# **RUS1680830** (Gray Primer)
- Item# **RUS1681830** (White Primer)
- Item# **RUS1684830** (Dove Gray)
- Item# **RUS1686830** (Universal Gray)
- Item# **RUS1688830** (Smoke Gray)
- Item# **RUS1690830** (Flat White)
- Item# **RUS1692830** (Glossy White)
- Item# **RUS1696830** (Antique White)
- Item# **RUS202211** (Machine Green)
- Item# **RUS202213** (Green Primer)
- Item# **RUS202214** (Machine Gray)
- Item# **RUS202216** (Dusty Pink)
- Item# **RUS214645** (ANSI 61 Light Gray)
- Item# **RUS214646** (ANSI 49 Med. Light Gray)
- Item# **RUS214647** (ANSI 70 Light Gray)
- Item# **RUS242657** (Metallic Bronze)



Spray Paint - Economical

OVERALL® ECONOMICAL ENAMEL AEROSOLS (V2400 System)



- Fast-dry – dries in 15 minutes.
- Indoor and outdoor use.
- Apply to a variety of surfaces (where long term durability is not required).
- Minimal surface preparation required.
- Guaranteed not to clog.

- Item# **RUS215404** (Beige)
- Item# **RUS215405** (Red Primer)
- Item# **RUS215406** (Medium Blue)
- Item# **RUS215409** (Light Gray)
- Item# **RUSV2401830** (Gray Primer)
- Item# **RUSV2402830** (Gloss Black)
- Item# **RUSV2403830** (Gloss White)
- Item# **RUSV2404830** (Flat Black)
- Item# **RUSV2405830** (Flat White)
- Item# **RUSV2407830** (Red)
- Item# **RUSV2408830** (Blue)
- Item# **RUSV2409830** (Yellow)
- Item# **RUSV2410830** (Green)
- Item# **RUSV2411830** (Brown)
- Item# **RUSV2412830** (Aluminum)
- Item# **RUSV2413830** (Gray)
- Item# **RUSV2414830** (Orange)



Spray Paint - Marking Paint

INDUSTRIAL CHOICE INVERTED MARKING PAINT AEROSOL (M1600 System)

Solvent-based marking paints feature a precision-line spray tip for easy-to-read bright, vivid markings for utility, construction, excavation, surveying, landscape and golf course markings.

- Best resistance against premature fading.
- No mess spray tip keeps paint off fingers.
- Locking tip does not pop off.
- Virtually no overspray.
- Dries fast — less than 5 minutes.
- Convenient spray-through cap.
- Guaranteed not to clog.
- USDA acceptable.*

- Item# **RUS1601838** (Clear)
- Item# **RUS1634838** (Safety Green)
- Item# **RUS1661838** (Fluorescent Pink)
- Item# **RUS1662838** (Fluorescent Red)
- Item# **RUS1668838** (Safety Purple)
- Item# **RUS1669838** (Fluorescent Purple)
- Item# **RUS1675838** (Black)
- Item# **RUS201516** (APWA Orange)
- Item# **RUS203022** (Caution Blue)
- Item# **RUS203023** (Fluorescent Green)
- Item# **RUS203024** (Caution Yellow)
- Item# **RUS203025** (High Visibility Yellow)
- Item# **RUS203026** (Alert Orange)
- Item# **RUS203027** (Fluorescent Orange)
- Item# **RUS203028** (Fluorescent Red-Orange)
- Item# **RUS203029** (Safety Red)
- Item# **RUS203030** (White)
- Item# **RUS239007** (Silver)



*Can be used in USDA facilities based on FSIS Directive 11,000.4 (Rev. 1), November 24, 1995.

EXPERIENCE THE DIFFERENCE

Spray Paint - Marking Paint Accessory



INDUSTRIAL CHOICE MARKING PISTOL

- Easy, accurate marking.
- Light touch spray control.
- Comfortable grip.

Item# **RUS210188**



INDUSTRIAL CHOICE MARKING WAND

- Easy, upright site marking.
- Quick and convenient with no mess.
- Comfortable grip.
- Lightweight, yet durable construction.
- Use with Rust-Oleum Inverted Marking Paint.

Item# **RUS2393000**



Abatix' online ordering system is simple to use. Once you are registered and have a customer code, you can create orders, customize shopping lists, and view ordering history, track shipments, view and print invoices and pay bills online. Head over to www.abatix.com and start shopping today.

Sundries - Rags & Towels

ASSORTED RAGS AND TOWELS



Item# **TWLSBT-15** (Towel, Scrim, 300/Case)
 Item# **RAGDIA25** (Knit Diaper Rags, 25 Lb./Box)
 Item# **RAGTCW25** (Rags, White Terry Cloth, 25 Lb./Case)

Item# **RAGFLC50** (Rags, Color Fleece, 50 Lb./Case)
 Item# **RAGTSC25** (Rags, Color T-Shirt Knit, 25 Lb./Case)
 Item# **RAGTKW10** (Rags, White Turkish Towel Rags, 10 Lb./Case)

Sundries

FOAM BRUSHES



These disposable brushes are constructed with premium, high-density foam and a sanded round wood handle. Not for use with shellacs or lacquers.

- Item# **PNTFPB-1** (1") Item# **PNTFPB-3** (3")
- Item# **PNTFPB-2** (2") Item# **PNTFPB-4** (4")

CHIP BRUSHES



These disposable brushes are constructed with 100% white china bristle and an unfinished wood handle with silver ferrule. Can be used with most paints, glues and adhesives.

Item#	Size	Length Cut	Thickness
PNTB12	1/2"	1-3/4"	1/4"
PNTB1	1"	1-3/4"	5/16"
PNTB112	1-1/2"	1-3/4"	5/16"
PNTB2	2"	1-3/4"	5/16"
PNTB212	2-1/2"	1-3/4"	3/8"
PNTB3	3"	1-3/4"	3/8"
PNTB4	4"	3"	23/64"

POLYESTER UTILITY BRUSHES



Economical utility brushes. Blue plastic handles with polyester filaments.

Item#	Size	Length Cut	Thickness
PNT241	1"	1-3/4"	5/16"
PNT242	2"	1-3/4"	5/16"
PNT243	2-1/2"	1-3/4"	3/8"
PNT244	4"	2-9/16"	18/25"

MINI ROLLER FRAMES

Assorted mini roller frames will fit most mini roller covers.



Item#	Size	Description
PNT4MINI	4"	w/ 19" Frame
PNT6MINI	6-1/2"	w/ 12" Frame

ROLLER FRAMES

Consumer style frames with threaded handle; 1/4" shaft.



Item#	Size	Description	Type
PNT312IMP	3"	Black handle	4-wire
PNT412IMP	4"	Black handle	4-wire
PNT912IMP	9"	Black handle	5-wire

ROLLER FRAME – Pro

5/16" shaft; 5-wire cage style. Pro roller frame.

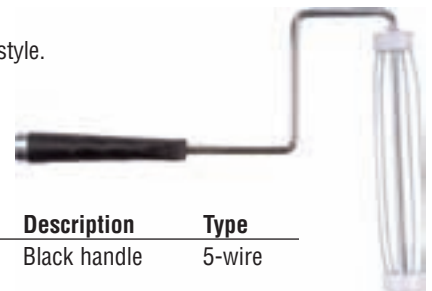

Item#	Size	Description	Type
PNT912R	9"	Black handle	5-wire

ROLLER COVER REFILLS – One Coat



Made from a deluxe 100% high density polyester fabric designed specifically to achieve one coat coverage when used with one coat paints. Features a heavy-duty moisture-resistant and solvent-resistant core. Best for flat and eggshell paints.

Item#	Size	Nap
PNT3AP038	3"	3/8"
PNT4AP038	4"	3/8"
PNT9AP038	9"	3/8"
PNT3-9ER050	9"	1/2"

EXPERIENCE THE DIFFERENCE

Sundries

DRAYLON MINI ROLLER REFILLS

Made from synthetic draylon fabric. Shed resistant for a lint-free application.

Item#	Size	Nap
PNT4EWV050D	4"	1/2"



MINI ROLLER COVER REFILLS – Perlon

Longer nap allows for great paint pick-up. Best with flat paints and stains.

Item#	Size
PNTSWV050-12	6-1/2"



PAINT SPRAY SOCK

Professional top-quality spray sock that has a 3-way stretch. Knitted from 100% combed cotton for maximum cooling and comfort. Protects hair and face for any place where over-spray, dust, fallout, etc. can get into hair, ears or shirt collars, etc.



Item# **PNTSS1PKB** (One Size Fits All)

PAINT STRAINER – Elastic Top

Made of tight nylon mesh. Use to strain all types of paints, stains and liquids. Removes dried flakes, lumps, filaments and other dust particles from paint. 25/box

Item# **PNTSTR5G** (5 Gal.)



PAINT MIXERS – Spiral

All steel for drywall mud, paint or cement.

Item# **PAINTMIXER-1** (1 Gal.)
Item# **PAINTMIXER-5** (5 Gal.)



METAL PAINT TRAY

For consumers or professionals. For use with up to 9" roller covers.

Item# **PNT9T** 11" x 15" x 2-1/2"



PAINT TRAY LINER – White

Plastic liner for standard and large volume metal tray.

Item# **PNTTL9** 11" x 15" x 2-1/2"



.70 MIL PLASTIC PAIL

Encore pails are molded from a low melt HDPE to ensure the best possible impact strength and resistance to cracking. Provides high standard shipping capabilities, eliminating danger of product contamination or loss. Widely used for paints, coatings, varnishes, water sealants, concrete patching compounds, asphalt coatings, printing inks, soaps and detergents. Tapered design for easy separation, maximum storage and shipping cube.

Item# **BUC5P** (5 Gal.)
Item# **BUC2P** (2 Gal.)
Item# **BUC1P** (1 Gal.)



ACID BRUSH



Designed for specialty use with acid, adhesives, soldering, etc. Good for other general purpose uses such as touch-up, cleaning, dusting, etc.

Item#	Size	Description
BRS1-HH	3/8"	#1

WIRE BRUSH – Refinishing

Mini wire brush for small hard-to-reach scraping, refinishing and cleaning.

Item#	Size	Description
BRS274	3 x 7"	Plastic bristles



WIRE BRUSH – Shoe Handle

Item# **BRSEC4S** (4 x 16 rows)



WIRE BRUSHES – Tempered Steel Bristles

Item# **BRS319CS** (3 x 19 rows)
Item# **BRS319-CSX** (3 x 19 rows, w/Scraper)



Sundries

PAINTERS TOOL – 5-in-1

High carbon steel blade with nylon handle.



Item#	Size	Description
SCR7221	2-1/2"	5-in-1

PUTTY KNIFE – Stiff

High carbon steel blade with nylon handle.



Item#	Size	Description
SCR5124	1-1/2"	Stiff

SCRAPER

Stamped carbon steel blade, hardened for durability. Ergonomic shape for comfortable grip.



Item#	Size	Description
SCR5304	3"	Stiff

SCRAPER – Stiff Chisel, Extra Heavy-duty

High carbon steel blade individually ground, polished, mirror finished and clear coated. Nylon Projection Interlock handle resists most common paint thinners and solvents. Full tang blade construction.



Item#	Size	Description
SCR440	4"	Stiff

UTILITY KNIFE – Top Slide



Top slide push button blade adjustment. 3 Cutting positions. Grey textured finish die cast zinc alloy construction. Overlap nose. 1 Heavy-duty blade included.

Item# **SCR2400**

UTILITY KNIFE BLADES



Heavy gauge steel for rugged use. Can be used in all standard utility knives. .025", 2-notch.

Item#	Size	Qty/pk
SCR2406	.025"	100

SINGLE EDGE RAZOR BLADES – Regular/Duro Edge Blade

High carbon surgical steel, single edge blades. Famous Duro Edge. Each blade protected in shelling paper.



Item#	Size	Qty/pk
SCRSE9	.009"	100

CAULK GUN – Hex Rod

Features smooth hex shaft with tip cutter and tube piercer.

Item# **LDS41001** (11 oz.)



CAULK GUN – Ratchet Drive Rod

Ratchet drive rod. Features auto reverse bushing with tip cutter and tube piercer.

Item# **LDS2000P** (11 oz.)



BOSS® 312 RTV HVAC/R SILICONE



- Permanently flexible.
- Adheres to glass, wood, metal, porcelain, ceramic tile, painted surfaces and rubber.
- May be applied in sub-zero weather without loss of extrusion or physical property characteristics.
- Meets NSF Standard 51.
- Meets FDA/USDA requirements for use in establishments operating under Federal Meat and Poultry Inspection Program.
- Insulates thermally and electrically.
- Waterproof and Weatherproof seal.

TYPICAL PROPERTIES

Uncured	
Colors	clear, white and aluminum
Slump	NIL
Tack-Free Time at 77°F (25°C) and 50% RH	10-20 min.
Cured – Physical	
<i>7 Days at 77°F (25°C) and 50% RH (1/8" thickness)</i>	
Elongation	500
Durometer, Shore A	30
Tensile Strength	350 psi
Movement Capacity	±25%
Extrusion Rate400 gr/min.
VOC30 grams/liter

- Item# **BOSS31200** (Clear)
- Item# **BOSS31201** (White)
- Item# **BOSS31203** (Aluminum)



EXPERIENCE THE DIFFERENCE

Surface Protection - Floor Protection

ENVIROGUARD

FLOOR SURFACE PROTECTION

CarpetGuard™, Enviromat™ and FloorGuard™ are temporary adhesive films that have been designed for use in the controlled environment, environmental, construction, recreational vehicle, commercial and residential building, marine and retail markets. CarpetGuard™, Enviromat™ and FloorGuard™ can be used wherever there is a need to diminish an influx of dirt and dust in a clean area. These products can save the user, contractor and owner from significant cleaning and repair costs.

CarpetGuard™ products roll out easily onto the carpet and stay in place. Made of tough 3 mil polyethylene material, which will offer protection for up to 45 days. CarpetGuard™ is an excellent product to protect stairways, hallways, entrances and exits along with high traffic areas in homes and offices.



- Item# **IESEMCG324200** (24" x 200", clear)
- Item# **IESEMCG336200** (36" x 200", clear)
- Item# **IESEMCG336500** (36" x 500", clear)

Enviromat™ contamination control products are multi-layered pads that remove particulate contaminants from foot traffic prior to entry into a clean or controlled environment. Each numbered layer is coated with an adhesive which causes the contaminants to adhere to the pad, removing them from the sole of the footwear. Once the top layer is thoroughly soiled, it can be easily removed, exposing the next layer which will allow the mat to return to its normal maximum efficiency.



- Item# **IESEM1836R30B** (18" x 36", Blue)
- Item# **IESEM2430R30W** (24" x 30", White)
- Item# **IESEM2436R30B** (24" x 36", Blue)
- Item# **IESEM2436R30W** (24" x 36", White)
- Item# **IESEM3636R30** (36" x 36", Clear)
- Item# **IESEM3645R30B** (36" x 45", Blue)

FloorGuard™ is made of a tough self-adhering 3 mil polyethylene material that provides a temporary protection for hard surfaces such as tile, marble and granite along with vinyl and factory hardwoods and laminates. Works well on countertops too! Great for painting, remodeling, moving and new construction. Available in four put-ups to meet your customers needs.



- Item# **IESEMG324200** (24" x 200", Blue)

CARPET MASK® – The original self-adhesive carpet protection



Carpet Mask® is the most effective way to temporarily protect synthetic carpets from damage during high traffic times.



Features

- 3 Mil thick, 3 mil tough.
- Tear resistant.
- Solvent acrylic adhesive technology.
- Reverse wound for easy roll out.
- Peels clean.



- Item# **PLYCM24X200** (24" x 200')
- Item# **PLYCM24X200GR** (24" x 200', Grey Tint)
- Item# **PLYCM36X200GR** (36" x 200', Grey Tint)

FLOORLINER® – Two-ply hardwood floor protection

Floorliner® can be used for up to 120 days on hardwood floors, linoleum, and counter tops. The padded protection prevents scratches, gouges, scuffs and dents. No taping required, just roll it out and it stays in place. Newly finished hardwood floors must be completely cured prior to use.

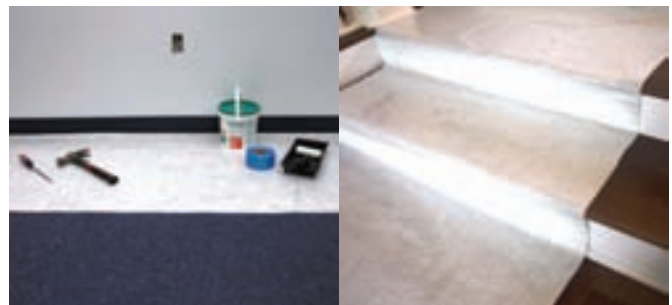

Features

- Two-ply hardwood protection.
- The ONLY RECOMMENDED hardwood protection.
- Self-adhesive – Stays in place.
- 120-Day use.
- Strong, tear resistant.

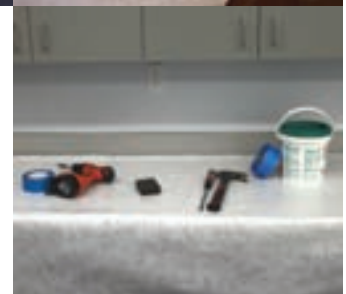

- Item# **PLYFLOOR40X56** (40" x 56')

Surface Protection - Floor Protection

FLOOR MASK® – Protects hard surfaces quickly and easily!



Floor Mask® is designed to provide temporary surface protection for hard surfaces. We do NOT recommend using Floor Mask® on finished hardwood floors. The specially formulated adhesive system is designed to stick well and stay in place on a hard surface and then peel clean.



Features

- 3 Mil thick, 3 mil tough.
- Tear resistant.
- Solvent acrylic adhesive technology.
- Reverse wound for easy roll out.
- Peels clean.



Item# **PLYFM24X200** (24" x 200')

STICKY MATS® – Self-adhesive clean room mats

Sticky Mats® significantly reduce traffic bourn contaminants by removing up to 97% of particles at the .30 micron level.



Features

- Multi layer protection. Thirty Layers, each layer 2 mil thick.
- Effective, durable, long lasting.
- Mat frames & colors available.
- High tech., abatement, dust control.
- Cost effective, easy to use.



Item# **PLYTM2436R30W** (24" x 36", White)
 Item# **PLYTM3636R30** (36" x 36", White)



FLOOR PROTECTION – Flame retardant polyethylene deck plate with a non-slip diamond pattern

The original cover guard® product was developed for the temporary protection of all types of floor finishes. It is also suitable for protecting walls, bulkheads, weatherdecks, furnishings and for wrapping and containment. It was specifically designed for use within the industrial sectors of rail, aviation, naval, cruise, ferry, luxury yacht, offshore, construction, for new building, refit, repair and maintenance.

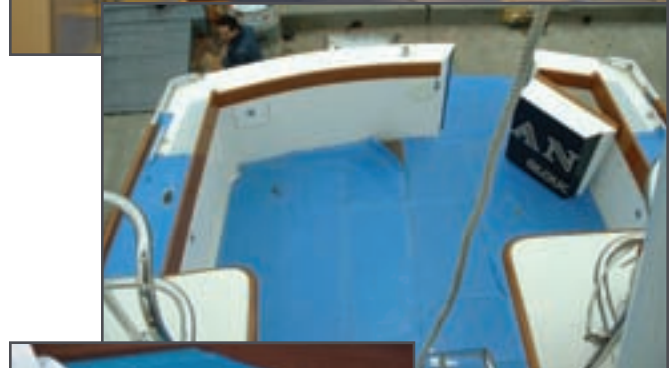

Each roll of cover guard® is supplied in an individual carton that is easy to store, transport and is light enough to be handled by 1 or 2 men. Overall, cover guard® ensures that effective protection can

be laid in the minimum amount of time with the least amount of effort and cost.

Item# **BBICG1036DP** (10 Mil x 36" x 393')
 Item# **BBICG1072DP** (10 Mil x 72" x 393')
 Item# **BBICG2536DP** (25 Mil x 36" x 180')
 Item# **BBICG4036DP** (40 Mil x 36" x 120')

EXPERIENCE THE DIFFERENCE

Surface Protection - Floor Protection



Ram Board is a heavy-duty, temporary floor protection engineered for Contractors. Designed with cost and efficiency in mind; it lays out fast and is re-usable. Ram Board is non-staining and utilizes Flex-Fiber™ technology allowing for the proper curing of new floors on jobsites. Exclusive Spill Guard™ technology provides added protection against water, paint, mud and more.

Item# **RAMBOARD** 38' x 100'

Surface Protection - Building Paper

Grip-Rite® Building Paper

Grip-Rite building paper is used to protect the surfaces of tile, hardwood floors, doors, windows and cabinets from paint, dirt, spills and other debris that all occur during the final stages of construction, moving or home projects.

Grip-Rite building paper is available in both brown and red colors. It is easy to use, and is available in a variety of sizes to fit every project.



Item No.	Description	Width	Length	Area	Rolls per Pallet
FLT15D4869	Red Rosin Paper	36 in. (91.4 cm)	144 ft. (43.9 m)	432 ft. ² (40.1 m ²)	36
RRPGR500	Red Rosin Paper	36 in. (91.4 cm)	166 ft. (50.6 m)	498 ft. ² (46.3 m ²)	75
RRPGR1000	Red Rosin Paper	72 in. (1.83 m)	166 ft. (50.6 m)	996 ft. ² (92.5 m ²)	75
BRP432	Brown Rosin Paper	36 in. (91.4 cm)	144 ft. (43.9 m)	432 ft. ² (40.1 m ²)	75
BRP500	Brown Rosin Paper	36 in. (91.4 cm)	166 ft. (50.6 m)	498 ft. ² (46.3 m ²)	75

Tape - Duct

MAX® DUCT TAPE



Good. All-purpose duct tape for a variety of uses at an economical price. Bonds to almost any surface. 9mil.

Item# **TYC214S** (2 in.)
Item# **TYC214S-3** (3 in.)



Better. Our medium grade tape, MAX Red tape offers aggressive adhesion and high shear strength. 10mil.

Item# **ADTRED** (2 in.)



The Original Abatix Blue

Best. The contractor's duct tape of choice. Superior adhesion and sheer strength for high performance applications. 11mil.

Item# **TYC224B** (2 in.)
Item# **TYC324B** (3 in.)

Item #	TYC214S	TYC214S-3	ADTRED	TYC224B	TYC324B
Color	Silver	Silver	Red	Blue	Blue
Thickness	9 mil	9 mil	10 mil	11 mil	11 mil
Width	2 in.	3 in.	2 in.	2 in.	3 in.
Adhesion	40 oz./in.	40 oz./in.	50 oz./in.	50 oz./in.	50 oz./in.
Tensile	18 lbs./in.	18 lbs./in.	20 lbs./in.	22 lbs./in.	22 lbs./in.
Shear	80 minutes	80 minutes	370 minutes	400 minutes	400 minutes
Unwind	27 oz./in.	27 oz./in.	34 oz./in.	45 oz./in.	45 oz./in.
Rolls/case	24	16	24	24	16

Tape - Masking

ScotchBlue™ PAINTERS MASKING TAPE



This blue masking tape removes cleanly without adhesive transfer or surface damage for up to 14 days, even in direct sunlight. It is a medium adhesion tape that is for multi-surfaces, ideal for painted walls and trim, woodwork, glass and metal.

- Item# **3M2090-1** (1 in. x 60 yd.)
- Item# **3M2090-1.5** (1.5 in. x 60 yd.)
- Item# **3M2090-2** (2 in. x 60 yd.)
- Item# **3M2090-3** (3 in. x 60 yd.)

Tape - General Purpose

3M™ GENERAL PURPOSE VINYL TAPE, BLACK



3M™ General Purpose Vinyl Tape, 5.0 mil (0.125mm) vinyl backing with a rubber adhesive, conformability and good instant adhesion is used in non-critical applications such as color coding, bundling and safety marking, temporary marking of parts or machines. It also protects parts, equipment and other products from abrasion.

- Item# **3M764-2BK** (2 in. x 36 yd.)

UTILITY GRADE MASKING TAPE



Features

- All-purpose tape for non-critical applications.
- Crepe paper coated with rubber based pressure-sensitive adhesive.
- Recommended for interior paint masking, silk screening, mail rooms, golf club shaft (build-up), school bids, and for light-duty bundling, packaging, splicing and tabbing.
- 5 Mil / Natural.

- Item# **TAPEMSK1** (1" x 60 yd.)
- Item# **TAPEMSK2** (2" x 60 yd.)

UTILITY GRADE GENERAL PURPOSE MASKING TAPE



Features

- Designed for good adhesion and clean removal at room temperature.
- For non-critical applications.
- Coated with an aggressive "solventless" synthetic adhesive.
- Recommended for hanging paper, poly and poster board. A great stationery masking tape.
- 5 Mil / Natural.

- Item# **TAPEPG500-2** (1.5" x 60 yd.)

PREMIUM PAINTERS GRADE MASKING TAPE



Features

- Fine structured crepe backed pressure sensitive tape.
- Designed for exposure to direct sunlight and high humidity levels for up to 14 days.
- Provides very clean paint lines and removes cleanly and easily from most surfaces.
- 5.5 Mil / Blue.

- Item# **TAPEPT14-1** (1" x 60 yd.)
- Item# **TAPEPT14-1.5** (1.5" x 60 yd.)
- Item# **TAPEPT14-2** (2" x 60 yd.)

MULTI-PURPOSE DOUBLE-COATED DUCT TAPE, 2"



Benefits and Features

- Cloth reinforcement – good strength and elongation for easy tear, application and removal. Conformable and moisture resistant.
- Natural rubber based adhesive – clean removal from most surfaces. High tack and aggressive adhesion for secure bond.
- Low VOC content.

Applications

- Carpet hold-down for the convention and entertainment industry.
- Hanging, seaming and splicing poly sheeting.
- General mounting and holding.

- Item# **TYC105**

PREMIUM PE FILM TAPE



Benefits and Features

- Polyethylene film backing – conformable and flexible, excellent durability and solvent resistance and withstands outdoor exposure and moisture.
- Natural rubber based adhesive – high tack for a secure bond. Repositionable and clean removal - no residue.
- Low VOC content.

Applications

- Stucco and plaster masking.
- General purpose outdoor masking.
- Surface protection in aerospace, automotive and manufacturing.
- Bundling, wrapping and repairs.
- General purpose abatement applications such as hanging and patching PE sheeting, securing waste disposal bags and more.

- Item# **TYC827** (2" x 60 yd.)
- Item# **TYC827-3** (3" x 60 yd.)

EXPERIENCE THE DIFFERENCE

Tape - General Purpose

CARTON SEALING TAPE



Features

- Light duty acrylic tape.
- For lightweight, non-critical box sealing, package repair and bundling applications.
- 2" x 110 yd.
- Use with hand dispenser.
- 1.7 Mil / Clear.

Item# **TAPE2CLR**

PRESERVATION TAPE



Features

- Polyethylene backed tape.
- Excellent adhesion to polyethylene and other surfaces.
- Clean removal, residue free.
- 4" x 36 yd.
- UV resistant / White.
- Conformable.
- Durable / Waterproof.

Item# **TYCPE8-4**

Tape - Filament

FILAMENT TAPE



Features

- RG300.
- A natural, BOPP backed filament tape.
- Ideal for non-critical packaging and shipping.
- Strong, flexible polypropylene film for moisture and abrasion resistance.
- Reinforced with uni-directional fiberglass filaments.
- 2" x 60 yd.

Item# **TAPERG300.41**

Tape - Barricade

BARRICADE TAPE – 3" x 1000'



Item# BTPC		(Caution)
Item# BTPDARWB		(Danger Asbestos)
Item# BTPD		(Danger)
Item# BTPDDNE		(Danger Do Not Enter)
Item# BTPDLH		(Danger Lead Hazard)
Item# BTPDAR		(Danger Asbestos Hazard)

Scotch® FILAMENT TAPE, CLEAR



Scotch® Filament Tape is a clear polypropylene backing reinforced with glass yarn filaments with a synthetic rubber resin adhesive.

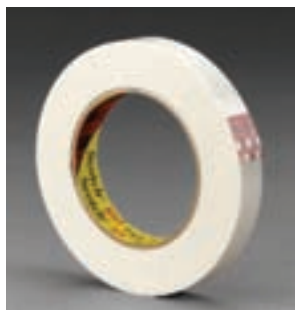

Benefits and Features

- Filament reinforced strapping tape provides excellent resistance to nicks and abrasion.
- Synthetic rubber adhesive has good shear strength to fiber board surfaces for bundling, strapping and reinforcing applications.
- Filament reinforced tape for demanding applications.
- General industrial, food and beverage and automotive parts.

- Box closing, palletizing, box reinforcing, and general bundling.

Item# **3M897-18MM** (1" x 60 yd.)

Item# **3M897-36MM** (1.5" x 60 yd.)

Did you know Abatix offers training courses? Located in our Santa Fe Springs, CA, Phoenix, AZ and Jacksonville, FL branches, Abatix Learning Centers offer a variety of certification classes regulated by both governmental and industry related groups, such as OSHA, EPA, Licensing groups (IICRC, IAQA, Maritime, and Construction), as well as product demonstrations and general industry informational sessions. Check our web site for details.

Temporary Power - Distribution & Cords



TEMPORARY POWER DISTRIBUTION CENTER



CEP's "G" Series Portable Power Distribution Centers have been engineered utilizing the latest in GFCI technology, providing the user with the highest level of electrical safety. These power distribution centers are protected by a GFCI module giving the user open neutral and reverse phasing protection. They are U.L. listed for outdoor use and designed to stand up to the toughest of jobsite conditions. Each unit has been carefully assembled to provide the ultimate in electrical safety as well as meeting current OSHA standards.

- GFCI's provide open neutral and reverse phasing protection.
- "Power On" indicator lights on GFCI's.
- 240V High Voltage Shut-Off with indicator light.
- 1 - 50 Amp 125/250 Volt feed through receptacle.
- 1 - 30 Amp 250 Volt non-GFCI receptacle.
- 6 - 20 Amp 125 Volt GFCI individually protected receptacles.

Cat. No.	Rating	Power Inlet	Power Outlet	Receptacles		GFI	Overload Protected	Wgt.
				Qty	Type			
6506G	U.L. Listed	CS6375	CS6369	6	L5-20R	Yes	Yes	29
	50 Amp 125/250 Volt			1	L6-30R	No	Yes	29
6506GU*	U.L. Listed	CS6375	CS6369	6	5-20R	Yes	Yes	28
	50 Amp 125/250 Volt			1	L6-30R	No	Yes	28

Specifications

Input current: 50 amp 1 phase 125/250 volt A.C. 3 pole 4 wire.
 Trip Level: 4-6 milliamps. Trip Time: Less than .025 seconds nominal.
 Chassis: 16 gauge steel. Top: 14 gauge steel. Legs: 10 gauge steel.
 Finish: 3 mils U.L. listed polyester powder coat.
 Dimensions: W=14.5" L=21" H=11".

OUTDOOR EXTENSION CORDS

-31° Power Flex Extension Cords

- Power Flex Cords have a temperature rating of -31°F.
- Water resistant.
- Low Profile, tapered, snag-free ends.
- Added webbed strain relief to prevent cracking and separations.



1201

Cat. No.	Length	Gauge	Type	Jacket	Color	Pack	Wgt.
1202	25'	12/3	SJTW	Vinyl	Yellow	6	22
1205	50'	12/3	SJTW	Vinyl	Yellow	6	40
1201	100'	12/3	SJTW	Vinyl	Yellow	4	55

Power Flex Twist-Lock Extension Cords

- Teflon inserts protect integrity of connector opening.
- Webbed strain relief.
- Soft and flexible jacket.



93181

Cat. No.	Length	Gauge	Type	Jacket	Color	Pack	Wgt.
93185	50'	12/3	SJTW	Vinyl	Yellow	6	45
93181	100'	12/3	SJTW	Vinyl	Yellow	4	57

ADAPTERS

"Y" Adapters



1474

Cat. No.	Lgth.	Gauge	Type	Jacket	Plug	Connector	Pack	Wgt.
1474	24"	12/3	STW	Vinyl	20A/125V L5-20P	20A/125V L5-15R	18	28
1473	24"	12/3	STW	Vinyl	15A/125V 5-15P	15A/125V 5-20R	18	20

"W" Adapters



1479

Cat. No.	Lgth.	Gauge	Type	Jacket	Plug	Connector	Pack	Wgt.
1480	24"	12/3	STW	Vinyl	20A/125V L5-20P Twist	20A/125V L5-20R Twist	12	25
1479	24"	12/3	STW	Vinyl	15A/125V 5-15P Straight	15A/125V 5-15R Straight	12	18

Power Blocks



Cat. No.	Lgth.	Gauge	Type	Jacket	Plug	Connector	Pack	Wgt.
8312	24"	12/3	STW	Vinyl	15A/125V 5-15P	15A/125V 5-15R	6	6

EXPERIENCE THE DIFFERENCE

Temporary Power - Cords & Work Lights

TEMPORARY POWER ACCESSORIES

Power Cords



6400S

Cat. No.	Length	Gauge	Type	Jacket	Devices	Pack	Wgt.
6450S	50'	6/3-8/1	STOW	Vinyl	6364 & 6365C	1	33
6400S	100'	6/3-8/1	STOW	Vinyl	6364 & 6365C	1	66

Wiring Devices 2 Pole 3 Wire



70520NP

NEMA Configuration		Male Plug	Female Connector	Flush Receptacle	Manufacturer
5-15	15A 125V	5266N	5269N		Bryant
L5-20	20A 125V	70520NP	70520NC	70520FR	Bryant

Y Adapters



Cat. No.	Length	Gauge	Type	Jacket	Devices	Pack	Wgt.
6404M	2'	6/4	SOW	Rubber	2-6364C & 1-6365C	1	5

LIGHT STRINGS

Twist Lock Plug & Connector Light Strings



95122



96122

Cat. No.	Lgth.	Gauge	Type	Jacket	Sockets	Guard	Pack	Wgt.
95122	100'	12/3	STW	Vinyl	10	Plastic	1	28
96122	100'	12/3	SJTW	Vinyl	10	Plastic	1	20

LED Light Strings

- 50,000 Hour lamp life.
- 15 Times more efficient than incandescent lighting.
- 90 LED - 6.6 Watt per fixture allows for connection up to 750' continuous.
- Very low heat output.
- Outdoor approved for wet locations.



Cat. No.	Length	Gauge	Type	Jacket	Color
97132	100'	18/2	SJTW	Vinyl	Yellow
97135	50'	18/2	SJTW	Vinyl	Yellow
97120	25'	18/2	SJTW	Vinyl	Yellow
9700	Replacement Magnetic Bracket				
9709	6.6w LED Replace. Panel Light	9710	10w LED Replace. Panel Light		

50 Amp Wiring Devices



Description	Plug	Connector	Receptacle	Inlet	Manufacturer
50 Amp 125/250 Volt	6365M	6364M	6369M	6375M	Marinco

GFCI Protection Adapters (All have 20 Amp circuitry.)



1443G2



1444G2

Cat. No.	Length	Gauge	Plug		Connector	
1440G2	2'	12/3 STW	Straight Blade 15A/125V	NEMA 5-15P	Straight Blade 15A/125V	NEMA (3) 5-15R
1443G2	2'	12/3 STW	Twist Lock 20A/125V	NEMA L5-20P	Twist Lock 20A/125V	NEMA L5-20R
1444G2	2'	12/3 STW	Straight Blade 15A/125V	NEMA 5-15P	Straight Blade 15A/125V	NEMA (3) 5-15R
1446G2	2'	12/3 STW	Twist Lock 20A/125V	NEMA L5-20P	Straight Blade 15A/125V	NEMA 5-15R
1447G2	2'	12/3 STW	Straight Blade 15A/125V	NEMA 5-15P	Twist Lock 20A/125V	NEMA L5-20R

ECONOMY IMPORT LIGHTS

Economy Import Lights

- Weatherproof and U.L. listed for use in wet locations.
- Sturdy double tripod base.
- One rough service quartz halogen bulb included with each fixture.
- Convenient cord wrap.



5125I

5165I

5610I

Cat. No.	Description	Height	Watt	Mast	Switch	Wgt.
5125I	Stubby	1'	500	n/a	No	5
5650I	Single Economy Fixture	6'	500	3 Stage	Yes	12
5610I	Double Economy Fixture	6'	1000	3 Stage	Yes	17

Temporary Power - Portable Work Lights



Bounces Back From Abuse!

The 36" tall Wobblelight® is ideal for applications requiring temporary high-output lighting in areas from 15 to 110 feet diameter. Bright and dependable, the self-righting Wobblelight® delivers maximum light output in a highly durable and portable package with no hot surfaces.

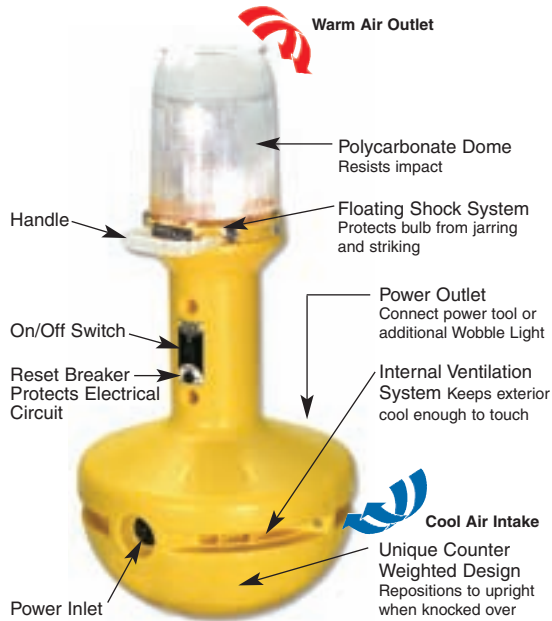

Features and Benefits

- Lumen output from 8,000 – 40,000
- Lighting radius from 16 – 110 ft.
- 36" Tall / 25 –29 lbs.
- Lexan dome w/ molded handle
- Tough reinforced ABS housing
- Floating bulb shock system
- Sealed on/off switch
- Fan-cooled lamp (400W and 500W)
- "No Burn" surface temperatures
- 110V Power inlet & outlet
- 12 Amp resettable circuit breaker
- Completely self-righting design

Applications

- High-rise and building construction
- Commercial / residential construction
- Renovation / demolition / remediation
- Industrial maintenance & turn-arounds
- Tank and vessel inspection / repair
- Aircraft and ship building / maintenance
- Emergency / disaster response

WOBBLELIGHT® UNIT	Mfr. Model No.	Lumens	Lamp Life	Lighting Range
Wobblelight® 36" 500 watt Halogen Work Light	WOLWL500H	8,000	2,000 hr.	15 - 25 ft.
Wobblelight® 36" 175 watt Metal Halide Work Light	WOLWL175MH	15,000	10,000 hr.	25 - 45 ft.
Wobblelight® 36" 400 watt Metal Halide Work Light	WOLWL400MH	40,000	20,000 hr.	50 - 110 ft.

Abatix' online ordering system is simple to use. Once you are registered and have a customer code, you can create orders, customize shopping lists, and view ordering history, track shipments, view and print invoices and pay bills online. Head over to www.abatix.com and start shopping today.

Temporary Power

EXPERIENCE THE DIFFERENCE

Temporary Power - Portable Generator

GP15000E & GP 17500E – Most Powerful Portable Generators



Power outages usually occur without warning. Ideally, a homeowner is prepared with an automatic home standby generator installed and always ready to go. However, if a portable generator is the only option for backup power during an emergency, the GP Series 15000 and 17500 Watt units are the ultimate option, with enough power to run up to a 5-ton air conditioner and more. Also an ideal choice for job sites with high power requirements. These models feature Generac's OHVI™ engine, for extended run times and longer life.

- **Idle control** reduces noise and conserves fuel for extended run-times.
- **Large Steel Fuel Tank with Easy-To-Read Fuel Gauge** – For durability and extended run times.
- **Integrated lifting eye** for easy transport and security on the job site.
- **Hardened 1-1/4" Steel Tube Cradle** – For added durability and strength.
- **Hour meter** tracks maintenance intervals.
- **Low Oil Shutdown** – Detects low oil level and shuts engine down to prevent potential engine damage.
- **Heavy-duty, pneumatic wheels** for reliable portability.



What's Included

- Wheel Kit
- Handle Kit
- Engine Oil
- Quick Start Guide
- Starting Battery
- Maintenance Kit

Specifications

Series	GP15000E	GP17500E
Model Number	GEN5734	GEN5735
Emissions Configuration	49-State	49-State
Running Watts	15000	17500
Starting Watts	22500	26250
Engine Displacement	992cc	
Engine Type	Generac OHVI	
Idle Control	Yes	
Starting Method	Electric	
Battery	Included	
Low Oil Shutdown	Yes	
Fuel Tank	Resin, 16 Gal (60.6 L)	
Run Time at 50% load	10 Hours	
Hour meter	Yes	
Outlets	(1) 120V 20A 5-20R Duplex (1) 120V 20A GFCI 5-20R Duplex (2) 120V L5-30R 30A Twist lock (1) 125/250V 30A L14-30R TwistLock (1) 125/250V 14-50R 50A Straight Blade (1) 12VDC, 10A	
Handle Style	Fixed	
Wheel Type	12.3" (312.4mm) Pneumatic	
Dimensions (L x W x H)	48.5" (1232mm) x 31" (787.4mm) x 39.5" (1003mm)	
Product Weight	363 (164.7)	390 (176.9)
Warranty - Residential	2 Year Ltd.	
Warranty - Commercial	1 Year Ltd.	

All portable specifications and models subject to change.



Generac OHVI® Engine

The only engine designed specifically for generator use.

Why is this important? Generators are often required to run for hours at a time, day after day. Generac's OHVI engine utilizes the same type of pressurized oil lubrication used to give automobile engines long and trouble free lives. Our engine has a significantly longer life than many competitive engines - an unprecedented three to four times longer. That's the reliability you need for the long run times emergency backup can require.



Temporary Power - Portable Generator

XP6500E – Professional-grade for demanding jobsites

The undisputed workhorse of the portable market, Generac's professional grade XP Series portable generators are engineered specifically with contractors in mind. All models are powered by the Generac OHVI® engine, built to withstand extended jobsite use.

- **The Generac OHVI® engine incorporates full pressure lubrication with automotive style spin on oil filter** for longer life engine.
- **Fold-down, Locking Handles** – Provide sturdy portability, fold down for compact storage, factory installed.
- **Integrated Lifting Eye** – For easier transportation and added security on jobsites.
- **Large Steel Fuel Tank with Integrated Fuel Gauge** – For extended run time and easy fuel tracking.
- **Hardened 1-1/4" Steel Tube Cradle and Cast Metal Corners** – For rugged durability.
- **Easy-to-access Maintenance Points** – Makes routine maintenance easier and quicker.
- **All-terrain, Never flat Wheels** – For mobility on any terrain.
- **TruePower™ Technology** – Delivers best-in-class power quality for confident operation of power tools, computers and more. With less than 5% total harmonic distortion, you're assured of quality and performance as smooth and consistent as utility power.



Easy Access all-in-one Control Panel

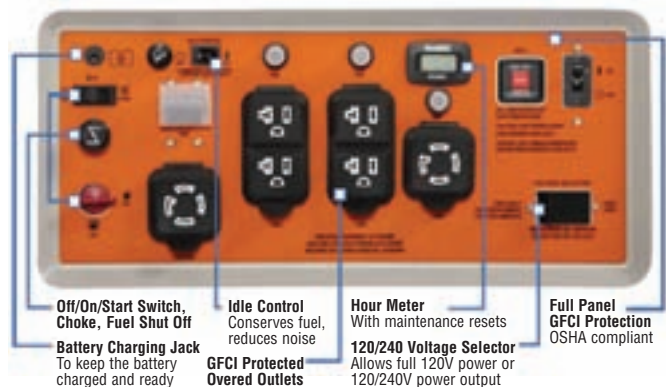

- Off/On/Start Switch, Choke, Fuel Shut Off**
- Battery Charging Jack**
To keep the battery charged and ready
- Idle Control**
Conserves fuel, reduces noise
- GFCI Protected Overed Outlets**
- Hour Meter**
With maintenance resets
- 120/240 Voltage Selector**
Allows full 120V power or 120/240V power output
- Full Panel GFCI Protection**
OSHA compliant

What's Included

- 3-Year Limited Warranty
- Owner's Manual
- Wheel Kit & Handles
- Maintenance Kit
- Engine Oil Supply

GENERAC OHVI® ENGINE

The power behind the performance.



The Generac OHVI engine utilizes the same type of pressurized oil lubrication used to give automobile engines long and trouble free lives and has a significantly longer life than many competitive engines – an unprecedented three to four times longer.

All portable specifications and models subject to change.

Specifications

Series	XP6500E
49-State / CSA Model #	GEN5930
CARB Model #	GEN5934
Running Watts	6500
Starting Watts	8125
Engine Displacement	407cc
Engine Type	Generac OHVI
Starting Method	Electric/Recoil Pull Start
Battery Included	Yes
Pressure Lube with Filter	Yes
Low Oil Pressure Shutdown	Yes
Fuel Tank	Steel, 9 Gal (34 L)
Run Time at 50% Load	11 Hours
Full-Panel GFCI Protection - OSHA Compliant	Yes
Idle Control	Yes
Total Harmonic Distortion	< 5%
120/240V Selector Switch	Yes
GFCI Protected Outlets	(2) 120V 20A 5-20R Duplex (1) 120V 30A L5-30R Twist lock (1) 120/240V 30A L14-30R Twist lock
Single-Point Lifting Eye	Included
Handle Style	Folding/Locking
Wheel Type	10" (254mm) Semi-Solid Wheels
Maintenance Kit	Included
Dimensions (L x W x H)	34.5" (879.5mm) x 26" (736.5mm) x 27.2" (690.5mm)
Product Weight	Model GEN5930 - 228 lbs (103.5 kg) Model GEN5934 - 235 lbs (106.5 kg)
Warranty - Residential	3-Year Ltd.
Warranty - Commercial	3-Year Ltd.

EXPERIENCE THE DIFFERENCE

Temporary Power - Portable Generator

XG6500 – Portable power for home or jobsite

- **Covered Outlets** – Provides added protection from the environment and rugged working conditions.
- **Easy to Read Fuel Gauge** – Easily monitors power wattage.
- **Exclusive Lighted PowerBar™** – Displays available power.
- **Illuminated LED Control Panel** – For improved visibility.
- **Fold-down, Locking Handle** – Easy portability, factory installed.
- **Compact Design** – Provides unparalleled power to weight ratio.
- **Heavy-duty, Never-flat, Rally-style Wheels** – Easier portability.



Convenient all-in-one Control Panel

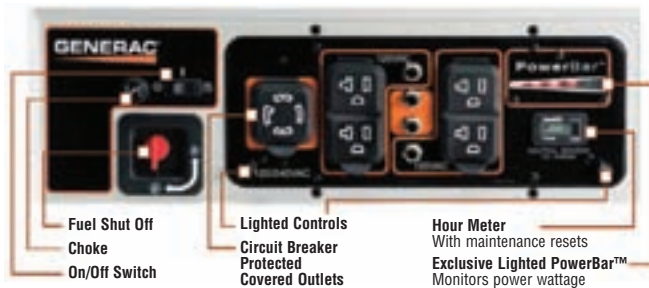

Specifications

Series	XG6500
Emission Certified	EPA/49-State
49-State Model	GEN5796
Watts (Running/Starting)	6500/8125
Engine	407cc Generac OHVI
Pressure Lube w/ Filter	Yes
Starting Method	Recoil Pull Start
Low Oil Pressure Shutdown	Yes
Fuel Tank Capacity	9 Gal. (34 L)
Run Time at 50%	10 Hours
Outlets (Covered)	(2) 120V 20A GFCI 5-20R Duplex (1) 120/240V 30A L14-30R Twist Lock
Handles	Folding/Locking
Wheels	9.5" (241.3mm) Semi-Solid Wheels
Dimensions (L x W x H)	32.5" (800mm) x 25.5" (648mm) x 28" (711mm)
Weight	Weight 225 lbs (102 kg)
Warranty - Residential	2-Year Ltd.
Warranty - Commercial	1-Year Ltd.

GENERAC™

LP5500 – Portable Propane Backup Power

- **Powerful 389cc Generac OHV Engine and Heavy Duty Alternator** – Deliver 5500 running Watts and 6875 starting Watts to power essential circuits.
- **PowerDial™** – Total control at the turn of a dial, with all startup and shutdown functions in one simple, easy-access control.
- **Quick-Access Enclosure** – For easy engine maintenance.
- **Folding/Nesting handle and Tank Holder** – For compact storage.
- **30 Amp Outlet & Manual Transfer Switch** – Allows generator to be easily connected to a permanently installed manual transfer switch to power several circuits and hardwired appliances.
- **Low-oil level shutdown** - Automatically safeguards engine from damage.
- **Precision Balanced** – For stability and effortless mobility.
- **Circuit Breakers** – Provide overload protection.
- **Conveniently Located Fuel Line** – Connects to standard LP tanks.
- **Hardened 1¼" Steel Tube Cradle** – Added durability and strength.
- **Hour Meter** – Automatically tracks maintenance intervals.
- **Heavy duty, Never-Flat Wheels** – easy transport regardless of terrain.

Tank not included



Specifications

Series	LP5500
Emission Certified	EPA - CARB
49-State Model	GEN6001
Watts (Running/Starting)	5500/6875
Engine	389cc Generac OHV
Low-oil Level Shutdown	Yes
Starting Method	Power Dial with Recoil Pull Start
Outlets (Covered)	120V 20A 5-20R Duplex 120/240V 30A L14-30R Twist lock
Fuel Tank	20 or 30 lb. Propane Tank (sold separately)
Run Time at 50%	4.75 Hours with 20 lb. Tank 7 Hours with 30 lb. Tank
Handles	Dolly-style, Folding, Locking
Wheels	10" (254mm) Solid Wheels
Dimensions (L x W x H)	35.4" (900mm) x 26.3" (669mm) x 36.2" (921mm)
Weight	Weight 184 lbs. (83.5 kg)
Warranty - Residential	2-Year Ltd.
Warranty - Commercial	1-Year Ltd.

All portable specifications and models subject to change.

Reference Charts - Nominal Wrench Openings

Nominal Wrench Openings as related to American National Standards Institute Bolts and Nut Sizes.

Nominal Wrench Opening	Regular Series Hex and Square Nuts and Bolts		Heavy Series Hex and Square Nuts Hex Head Bolts		Finished Series Regular and Thick Hex Nuts Hex Head Bolts		For Hex Head CAP Screws Diameters of Screws	For Square Head Set Screws Diameters of Screws	For Square or Hex Machines Screw Nuts and Stove Bolts Nuts Size or Diam.
	For Nuts For These Sizes of Bolts	For Heads of Bolts of These Diameters	For Nuts for These Sizes of Bolts	For Heads of Bolts of These Diameters	For Nuts For These Sizes of Bolts	For Heads of Bolts of These Diameter			
5/32									No. 0 and 1
3/16								No. 10	No. 2 and 3
7/32								No. 12	
1/4								1/4	No. 4
5/16								5/16	No. 5 and 6
11/32									No. 8
3/8		1/4						3/8	No. 10
7/16	1/4	1/4			1/4	1/4	1/4	7/16	No. 12 and 1/4
1/2		5/16	1/4		5/16	5/16	5/16	1/2	
9/16	5/16	3/8	5/16		3/8	3/8	3/8	9/16	5/16
19/32									
5/8	3/8	7/16				7/16	7/16	5/8	3/8
11/16			3/8		7/16				
3/4	7/16	1/2	7/16		1/2	1/2	1/2	3/4	
25/32									
13/16	1/2	9/16				9/16	9/16		
7/8	9/16		1/2	1/2	9/16			7/8	
15/16		5/8	9/16		5/8	5/8	5/8		
1	5/8							1	
1-1/16			5/8	5/8					
1-1/8	3/4	3/4			3/4	3/4	3/4	1-1/8	
1-1/4			3/4	3/4				1-1/4	
1-5/16	7/8	7/8			7/8	7/8	7/8		
1-3/8								1-3/8	
1-7/16			7/8	7/8					
1-1/2	1	1			1	1	1	1-1/2	
1-5/8			1	1					
1-11/16	1-1/8	1-1/8			1-1/8	1-1/8	1-1/8		
1-13/16			1-1/8	1-1/8					
1-7/8	1-1/4	1-1/4			1-1/4	1-1/4	1-1/4		
2			1-1/4	1-1/4					
2-1/16	1-3/8	1-3/8			1-3/8	1-3/8	1-3/8		
2-3/16			1-3/8	1-3/8					
2-1/4	1-1/2	1-1/2			1-1/2	1-1/2	1-1/2		
2-3/8			1-1/2	1-1/2					
2-7/16	1-5/8	1-5/8			1-5/8	1-5/8			
2-9/16			1-5/8	1-5/8					
2-5/8	1-3/4	1-3/4			1-3/4	1-3/4			
2-3/4			1-3/4	1-3/4					
2-13/16	1-7/8	1-7/8			1-7/8	1-7/8			
2-15/16			1-7/8	1-7/8					
3	2	2			2	2			
3-1/8			2	2					
3-1/4	2-1/4	2-1/4			2-1/4	2-1/4			
3-1/2			2-1/4	2-1/4					
3-3/4	2-1/2	2-1/2			2-1/2	2-1/2			
3-7/8			2-1/2	2-1/2					
4-1/8	2-3/4	2-3/4			2-3/4	2-3/4			
4-1/4			2-3/4	2-3/4					
4-1/2	3	3			3	3			
4-5/8			3	3					
4-7/8		3-1/4							
5			3-1/4						
5-1/4		3-1/2							
5-3/8			3-1/2						
5-5/8		3-3/4							
5-3/4			3-3/4						



Reference Charts - Equivalent Measures & Multipliers

LINEAR MEASURE

12 inches = 1 foot
 3 feet = 1 yard
 5½ yards = 1 rod
 40 rods = 1 furlong
 8 furlongs = 1 mile

EQUIVALENT VALUES

Inches	Feet	Yards	Rods	Furlongs	Miles
36	= 3	= 1			
198	= 16.5	= 5.5	= 1		
1,920	= 660	= 220	= 40	= 1	
93,360	= 5,280	= 1,760	= 320	= 8	= 1

SQUARE MEASURE

144 square inches = 1 square foot
 9 square feet = 1 square yard
 30¼ square yards = 1 square rod
 160 square rods = 1 acre
 640 acres = 1 square mile

EQUIVALENT VALUES

1 square mile = 640 acres = 102,400 square rods = 3,097,600 square yards
 1 square mile = 27,878,400 square feet = 4,014,489,600 square inches

CUBIC MEASURE

1,728 cubic inches = 1 cubic foot
 27 cubic feet = 1 cubic yard
 128 cubic feet = 1 cord
 24¾ cubic feet = 1 perch
 1 cubic yard = 27 cubic feet = 46,656 cubic inches

WEIGHT — AVOIRDUPOIS

437½ grains = 1 ounce
 16 ounces = 1 pound
 100 pounds = 1 hundredweight
 2,000 pounds = 1 ton
 2,240 pounds = 1 long ton
 1 ton = 20 cwt = 2,000 pounds = 32,000 ounces = 14,000,000 grains
 1 pound avdp = 7,000 grains

WEIGHT — TROY

24 grains = 1 pennyweight
 20 pennyweights = 1 ounce
 12 ounces = 1 pound
 1 pound = 12 ounces = 240 pennyweights = 5,760 grains

DRY MEASURE

2 pints = 1 quart
 8 quarts = 1 peck
 4 pecks = 1 bushel
 1 bushel = 4 pecks = 32 quarts = 64 pints
 U.S. bushel = 2,150.42 cu. in.
 British = 2,218.19 cu. in.

LIQUID MEASURE

4 gills = 1 pint
 2 pints = 1 quart
 4 quarts = 1 gallon
 The Imperial gallon contains 277.41 cu. in. = 0.1605 cu. ft.
 1 cubic foot of water = 6.2321 Imperial gallons and weighs 62.321 lbs.
 1 Imperial gallon of water weighs 10 lbs.

MEASURE OF ANGLES OR ARCS

60 seconds = 1 minute
 60 minutes = 1 degree
 90 degrees = 1 right angle or quadrant
 360 degrees = 1 circle
 1 circle = 360° = 21,600' = 1,296,000"
 1 minute of arc on the earth's surface = 1 nautical mile = 1.17 times a land mile or 6,080 feet.

MARINERS' MEASURE

6 feet = 1 fathom
 5,280 feet = 1 statute mile
 120 fathoms = 1 cable length
 6080 feet = 1 nautical mile
 7½ cable lengths = 1 mile

MISCELLANEOUS

3 inches = 1 palm	18 inches = 1 cubit
4 inches = 1 hand	21.8 inches = 1 Bible cubit
9 inches = 1 span	2½ feet = 1 military pace
12 articles = 1 dozen	1 league = 3 miles
12 dozen = 1 gross	20 articles = 1 score
12 gross = 1 great gross	25 sheets = 1 quire
2 articles = 1 pair	20 quires = 1 ream

TABLE OF MULTIPLIERS

Diameter of a circle X 3.1416 = Circumference.
 Radius of a circle X 6.283185 = Circumference.
 Square of the radius of a circle X 3.1416 = Area.
 Square of the diameter of a circle X 0.7854 = Area.
 Square of the circumference of a circle X 0.07958 = Area.
 Half of the circumference of a circle X half its diameter = Area.
 Circumference of a circle X 0.159155 = Radius.
 Square root of the area of a circle X 0.56419 = Radius.
 Circumference of a circle X 0.31831 = Diameter.
 Square root of the area of a circle X 1.12838 = Diameter.
 Diameter of a circle X 0.866 = Side of an inscribed equilateral triangle.
 Diameter of a circle X 0.7071 = Side of an inscribed square.
 Circumference of a circle X 0.225 = Side of an inscribed square.
 Circumference of a circle X 0.282 = Side of an equal square.

Diameter of a circle X 0.8862 = Side of an equal square.
 Base of a triangle X half the altitude = Area.
 Multiplying both diameters and .7854 together = Area of an ellipse.
 Surface of a sphere X one-sixth of its diameter = Volume.
 Circumference of a sphere X its diameter = Surface.
 Square of the diameter of a sphere X 3.1416 = Surface.
 Square of the circumference of a sphere X 0.3183 = Surface.
 Cube of the diameter of a sphere X 0.5236 = Volume.
 Cube of the circumference of a sphere X 0.016887 = Volume.
 Radius of a sphere X 1.1547 = Side of an inscribed cube.
 Area of its base X one-third of its altitude = Volume of a cone or pyramid, whether round, square or triangular.
 Area of one of its sides X 6 = Surface of a cube.
 Altitude of trapezoid X one-half the sum of its parallel sides = Area.

Reference Charts - Fraction/Decimal and Temperature Conversions

FRACTION - DECIMAL CONVERSION CHART

	Inches	Millimeters		Inches	Millimeters
$\frac{1}{64}$.015625	.3969	$\frac{33}{64}$.515625	13.0969
$\frac{1}{32}$.03125	.7938	$\frac{17}{32}$.53125	13.4938
$\frac{3}{64}$.046875	1.1906	$\frac{35}{64}$.546875	13.8907
$\frac{1}{16}$.0625	1.5875	$\frac{9}{16}$.5625	14.2876
$\frac{5}{64}$.078125	1.9844	$\frac{37}{64}$.578125	14.6844
$\frac{3}{32}$.09375	2.3813	$\frac{19}{32}$.59375	15.0813
$\frac{7}{64}$.109375	2.7781	$\frac{39}{64}$.609375	15.4782
$\frac{1}{8}$.125	3.1750	$\frac{5}{8}$.625	15.8751
$\frac{9}{64}$.140625	3.5719	$\frac{41}{64}$.640625	16.2719
$\frac{5}{32}$.15625	3.9688	$\frac{21}{32}$.65625	16.6688
$\frac{11}{64}$.171875	4.3656	$\frac{43}{64}$.671875	17.0657
$\frac{3}{16}$.1875	4.7625	$\frac{11}{16}$.6875	17.4625
$\frac{13}{64}$.203125	5.1594	$\frac{45}{64}$.703125	17.8594
$\frac{7}{32}$.21875	5.5563	$\frac{23}{32}$.71875	18.2563
$\frac{15}{64}$.234375	5.9531	$\frac{47}{64}$.734375	18.6532
$\frac{1}{4}$.250	6.3500	$\frac{3}{4}$.750	19.0501
$\frac{17}{64}$.265625	6.7469	$\frac{49}{64}$.765625	19.4470
$\frac{9}{32}$.28125	7.1438	$\frac{25}{32}$.78125	19.8438
$\frac{19}{64}$.296875	7.5406	$\frac{51}{64}$.796875	20.2407
$\frac{5}{16}$.3125	7.9375	$\frac{13}{16}$.8125	20.6376
$\frac{21}{64}$.328125	8.3344	$\frac{53}{64}$.828125	21.0345
$\frac{11}{32}$.34375	8.7313	$\frac{27}{32}$.84375	21.4313
$\frac{23}{64}$.359375	9.1282	$\frac{55}{64}$.859375	21.8282
$\frac{3}{8}$.375	9.5250	$\frac{7}{8}$.875	22.2251
$\frac{25}{64}$.390625	9.9219	$\frac{57}{64}$.890625	22.6220
$\frac{13}{32}$.40625	10.3188	$\frac{29}{32}$.90625	23.0188
$\frac{27}{64}$.421875	10.7157	$\frac{59}{64}$.921875	23.4157
$\frac{7}{16}$.4375	11.1125	$\frac{15}{16}$.9375	23.8126
$\frac{29}{64}$.453125	11.5094	$\frac{61}{64}$.953125	24.2095
$\frac{15}{32}$.46875	11.9063	$\frac{31}{32}$.96875	24.6063
$\frac{31}{64}$.484375	12.3032	$\frac{63}{64}$.984375	25.0032
$\frac{1}{2}$.500	12.7001	1	1.000	25.4001

TEMPERATURE CONVERSIONS

Look up reading in middle column (shaded). If in degrees Centigrade, read Fahrenheit equivalent in right-hand column; if in degrees Fahrenheit, read Centigrade equivalent in left-hand column.

°C	°F	°F	°C	°F	°F	°C	°F	°F
-73	-100	-148	5.0	41	105.8	33.3	92	197.6
-68	-90	-130	5.6	42	107.6	33.9	93	199.4
-62	-80	-112	6.1	43	109.4	34.4	94	201.2
-57	-70	-94	6.7	44	111.2	35.0	95	203.0
-51	-60	-76	7.2	45	113.0	35.6	96	204.8
-46	-50	-58	7.8	46	114.8	36.1	97	206.6
-40	-40	-40	8.3	47	116.6	36.7	98	208.4
-34	-30	-22	8.9	48	118.4	37.2	99	210.2
-29	-20	-4	9.4	49	120.2	37.8	100	212.0
-23	-10	14	10.0	50	122.0			
-17.8	0	32	10.6	51	123.8	43	110	230
-17.2	1	33.8	11.1	52	125.6	49	120	248
-16.7	2	35.6	11.7	53	127.4	54	130	266
-16.1	3	37.4	12.2	54	129.2	60	140	284
-15.6	4	39.2	12.8	55	131.0	66	150	302
-15.0	5	41.0	13.3	56	132.8	71	160	320
-14.4	6	42.8	13.9	57	134.6	77	170	338
-13.9	7	44.6	14.4	58	136.4	82	180	356
-13.3	8	46.4	15.0	59	138.2	88	190	374
-12.8	9	48.2	15.6	60	140.0	93	200	392
-12.2	10	50.0	16.1	61	141.8	99	210	410
-11.7	11	51.8	16.7	62	143.6	100	212	413.6
-11.1	12	53.6	17.2	63	145.4	104	220	428
-10.6	13	55.4	17.8	64	147.2	110	230	446
-10.0	14	57.2	18.3	65	149.0	116	240	464
-9.4	15	59.0	18.9	66	150.8	121	250	482
-8.9	16	60.8	19.4	67	152.6	127	260	500
-8.3	17	62.6	20.0	68	154.4	132	270	518
-7.8	18	64.4	20.6	69	156.2	138	280	536
-7.2	19	66.2	21.1	70	158.0	143	290	554
-6.7	20	68.0	21.7	71	159.8	149	300	572
-6.1	21	69.8	22.2	72	161.6	154	310	590
-5.6	22	71.6	22.8	73	163.4	160	320	608
-5.0	23	73.4	23.3	74	165.2	166	330	626
-4.4	24	75.2	23.9	75	167.0	170	338	640
-3.9	25	77.0	24.4	76	168.8	171	340	644
-3.3	26	78.8	25.0	77	170.6	177	350	662
-2.8	27	80.6	25.6	78	172.4	182	360	680
-2.2	28	82.4	26.1	79	174.2	186	366	691
-1.7	29	84.2	26.7	80	176.0	188	370	698
-1.1	30	86.0	27.2	81	177.8	193	380	716
-.6	31	87.8	27.8	82	179.6	198	388	730
0	32	89.6	28.3	83	181.4	199	390	734
.6	33	91.4	28.9	84	183.2	204	400	752
1.1	34	93.2	29.4	85	185.0	208	406	763
1.7	35	95.0	30.0	86	186.8	210	410	770
2.2	36	96.8	30.6	87	188.6	216	420	788
2.8	37	98.6	31.1	88	190.4	221	430	806
3.3	38	100.4	31.7	89	192.2	227	440	824
3.9	39	102.2	32.2	90	194.0	232	450	842
4.4	40	104.0	32.8	91	195.8			

Reference Charts



Reference Charts - Tap Drill Sizes

Tap Drill Sizes for Fractional Size Threads
Approximately 65% Depth Thread / American National Thread Form

Tap Size	Threads per Inch	Hole Diameter	Drill
1/16	72	.049	3/64
1/16	64	.047	3/64
1/16	60	.046	56
5/64	72	.065	52
5/64	64	.063	1/16
5/64	60	.062	1/16
5/64	56	.061	53
3/32	60	.077	5/64
3/32	56	.076	48
3/32	50	.074	49
3/32	48	.073	49
7/64	56	.092	42
7/64	50	.090	43
7/64	48	.089	43
1/8	48	.105	36
1/8	40	.101	38
1/8	36	.098	40
1/8	32	.095	3/32
9/64	40	.116	32
9/64	36	.114	33
9/64	32	.110	35
5/32	40	.132	30
5/32	36	.129	30
5/32	32	.126	1/8
11/64	36	.145	27
11/64	32	.141	9/64
3/16	36	.161	20
3/16	32	.157	22
3/16	30	.155	23
3/16	24	.147	26
13/64	32	.173	17
13/64	30	.171	11/64
13/64	24	.163	20
7/32	32	.188	12
7/32	28	.184	13
7/32	24	.178	16
15/64	32	.204	6
15/64	28	.200	8
15/64	24	.194	10
1/4	32	.220	7/32
1/4	28	.215	3
1/4	27	.214	3
1/4	24	.209	4
1/4	20	.201	7
5/16	32	.282	9/32
5/16	27	.276	J
5/16	24	.272	I
5/16	20	.264	17/64
5/16	18	.258	F
3/8	27	.339	R
3/8	24	.334	Q
3/8	20	.326	21/64
3/8	16	.314	5/16
7/16	27	.401	Y
7/16	24	.397	X
7/16	20	.389	25/64
7/16	14	.368	U
1/2	27	.464	15/32
1/2	24	.460	29/64

Tap Size	Threads per Inch	Hole Diameter	Drill
1/2	20	.451	29/64
1/2	13	.425	27/64
1/2	12	.419	27/64
9/16	27	.526	17/32
9/16	18	.508	33/64
9/16	12	.481	31/64
5/8	27	.589	19/32
5/8	18	.571	37/64
5/8	12	.544	35/64
5/8	11	.536	17/32
11/16	16	.627	5/8
11/16	11	.599	19/32
3/4	27	.714	23/32
3/4	16	.689	11/16
3/4	12	.669	43/64
3/4	10	.653	21/32
13/16	12	.731	47/64
13/16	10	.715	23/32
7/8	27	.839	27/32
7/8	18	.821	53/64
7/8	14	.805	13/16
7/8	12	.794	51/64
7/8	9	.767	49/64
15/16	12	.856	55/64
15/16	9	.829	53/64
1	27	.964	31/32
1	14	.930	15/16
1	12	.919	59/64
1	8	.878	7/8
1-1/16	8	.941	15/16
1-1/8	12	1.044	1-3/64
1-1/8	7	.986	63/64
1-3/16	7	1.048	1-3/64
1-1/4	12	1.169	1-11/64
1-1/4	7	1.111	1-7/64
1-5/16	7	1.173	1-11/64
1-3/8	12	1.294	1-19/64
1-3/8	6	1.213	1-7/32
1-1/2	12	1.419	1-27/64
1-1/2	6	1.338	1-11/32
1-5/8	5-1/2	1.448	1-29/64
1-3/4	5	1.555	1-9/16
1-7/8	5	1.680	1-11/16
2	4-1/2	1.783	1-25/32
2-1/8	4-1/2	1.909	1-29/32
2-1/4	4-1/2	2.034	2-1/32
2-3/8	4	2.131	2-1/8
2-1/2	4	2.256	2-1/4
2-5/8	4	2.381	2-3/8
2-3/4	4	2.506	2-1/2
2-7/8	3-1/2	2.597	2-19/32
3	3-1/2	2.722	2-23/32
3-1/8	3-1/2	2.847	2-27/32
3-1/4	3-1/2	2.972	2-31/32
3-3/8	3-1/4	3.075	3-1/16
3-1/2	3-1/4	3.200	3-3/16
3-5/8	3-1/4	3.325	3-5/16
3-3/4	3	3.425	3-7/16
4	3	3.675	3-11/16

Reference Charts - How to Size Generators

ELECTRICAL TERMS AND DEFINITIONS

Volt (E) — Unit of electrical pressure, electromotive force (e.m.f.) or difference of potential. Force required to send one ampere of current through one ohm of resistance.

Ampere (I) — Unit of current strength or current flow. The current which one volt can send through a resistance of one ohm.

Ohm (R) — Unit of electrical resistance. The resistance offered to the passage of one ampere, when impelled by one volt.

Impedance (Z) — Resistance of an alternating current circuit having both resistance and reactance. The impedance is always the vector sum of resistance and reactance.

Watt (W) — The unit of electrical energy. The product of the ampere and volt. One ampere of current flowing under a pressure of one volt gives one watt of energy.

Kilowatt (K.W.) — 1,000 watts — Large (usual) unit for measurement of power.

Horse Power (H.P.) — Mechanical unit for measurement of power or rate of work. Work required to raise 33,000 pounds one foot in one minute, and equals 746 or 0.746 K.W.

Watt-Hour — Electrical unit of work or energy. Watt-hours equal watts times hours.

Kilowatt-Hour (K.W.-Hr.) — 1,000 watt-hours. Large (usual) unit of work or energy.

Cycle — The period of a complete alternation of an alternating current circuit, comprising a positive and negative alternation.

Frequency (of alternating current) — Number of cycles per second.

Single-Phase — The term applied to an alternating current circuit energized by a single alternating e.m.f. Such a circuit is usually supplied through two wires.

Polyphase — A general term applied to an alternating system with more than one phase. See two-phase, three-phase, etc.

Two-phase — The term applied to an alternating system comprising two electric circuits energized by alternating e.m.f.'s which differ in phase by a quarter of a cycle — frequently referred to as quarter-phase.

Three-phase — The term applied to an alternating system comprising three electric circuits energized by alternating e.m.f.'s which differ in phase by one-third of a cycle.

Power-Factor (P.F.) — The power-factor is the ratio of true power to apparent power of an alternating current system. The power-factor may be expressed as a percentage but is usually written as a decimal fraction.

Volt-Ampere — Product of volts and Ampere.

Kilovolt-Ampere (K.V.A.) — 1,000-volt Ampere.

*Approximate wattage consumption of running and starting electric motors.

Motor	Approximate RUNNING Wattage				Approximate STARTING Wattage			
	Split Phase Motors		Repulsion Induction Motors		Capacitor Start Motors			
	Full Load	Average Load	Full Load	Average Load	Full Load	Average Load	Full Load	Average Load
1/6	528	343	5,280	3,432	1,320	858	2,112	1,373
1/4	696	453	6,960	4,524	1,740	1,131	2,784	1,810
1/3	864	562	8,640	5,616	2,160	1,404	3,456	2,246
1/2	1,176	765	11,760	7,644	2,940	1,911	4,704	3,058
3/4	1,656	1,076			4,140	2,691	6,624	4,306
1	1,920	1,248			4,800	3,120	7,678	4,992
1-1/2	2,400	1,560			6,000	3,900	9,600	6,240
2	2,880	1,872			7,200	4,680	11,520	7,488
3	4,080	2,652			10,200	6,630	16,320	10,608
5	6,720	4,368			16,800	10,920	26,880	17,472
7-1/2	9,600	6,240			24,000	15,600	38,400	24,960
10	12,000	7,800			30,000	19,500	48,000	31,200

Total all requirements, and add approximately 25 percent for overlooked items and miscalculations.

Select an alternator that is equal to or greater than the rated output requirement of your load.

Never pick an alternator smaller than your load requirement, as damage can be done to the alternator by continuously overloading it.

*APPROXIMATE WATTAGE CONSUMPTION (Running Load)

Home	Kitchen Ventilator	150	Milking Machine.....	1,000 & up
Sump Pump	Radio.....	40-100	Milk Cooler.....	1,000 & up
Refrigerator	Television	200-600	Milk Pump.....	.800 & up
Freezer.....	Washing Machine	400-600	Barn Cleaner	2,000 & up
Air Conditioner.....	Dishwasher	300	Feed Conveyor600 & up
Toaster	Sewing Machine.....	200-500	Silage Unloader.....	3,000 & up
Skillet.....	Vacuum Cleaner.....	400 & up	Chick Brooder.....	.100 & up
Mixer, Portable	Light Bulbs	As Marked	1/4" Electric Drill.....	.250
Coffee Maker.....	Electric Heat System	5,000-20,000	1/2" Electric Drill.....	.750
Iron, Steam & Dry.....			1" Electric Drill.....	1,000
Range, Electric - One element.....	Lawn & Garden		9" Disc Sander.....	1,200
Water Heater, Electric.....	Hedge Trimmer.....	450	3" Belt Sander.....	1,000
Clothes Dryer, Electric	Weed Eater.....	500	Concrete Vibrator	2,500
Furnace Oil Burner	Edge Trimmer.....	1,100	Circular Saw 6-1/2"	1,000
Furnace Blower Motor 1/4HP.....	Lawn Mower.....	1,200	Impact, Electric950
Furnace Blower Motor 1/3HP.....	Chainsaw	1,200-2,500	12" Electric Chain Saw	1,100
Circulating Heater.....			14" Band Saw	1,100
Glow Heater.....	Farm & Industrial		7-1/4" Circular Saw900
Electric Fan	Battery Charger.....	750	8-1/4" Circular Saw	1,400

*Figures are approximate. Check nameplates and literature on your equipment for specific consumption and starting requirements.



Manufacturers Represented

3M	211-214, 217-218, 262-263	MCR Safety	180-182, 184, 197-202, 231-232
Abatix®	3, 20-21, 39, 81, 180, 218	Merit Pro®	256-258
Accuform Signs	238-243	Midwestern Plastic Products	151
Advanced Containment Systems, Inc.	77	Miller® by Honeywell	186, 189
Aerospace America, Inc.	43, 76	Milwaukee Electric Tool	23, 135, 168-174
Allegro Industries	128	Mine Safety Appliances Company	127, 205-206, 218
Ames True Temper	116-121, 148	Mintie Corporation	41-42
Anabec Systems	29	Nilfisk-Advance America, Inc.	74
Apex Tool Group	82-83, 115, 120, 149	North® by Honeywell	196, 215-216
Atrix International, Inc.	75	Omnitec Design, Inc.	77
Bainbridge International, Inc.	260	Onguard Industries	233
Benefect	30, 33	Pacific Strapping, Inc.	50
Boss Products	258	Pearl Abrasive Company	3, 20-21
Brulin & Co., Inc.	30	Pelican Products, Inc.	12-13, 24
BW Technologies by Honeywell	125, 127	Phoenix™ Restoration Equipment (Division of Therma-Stor LLC) ..	62, 64-66
Capital Safety	185-195	Polyken® (Berry Plastics Corporation) ..	262
CEP Construction Electrical Products ..	264-265	Poly-Tak Protection Systems, Inc.	259-260
Channellock, Inc.	96-98	Power-Flite® (Tacony Corporation)	61, 66
Complete Environmental Products, Inc.	244-247	ProBuilt Professional Lighting, LLC	266
Continental Commercial Products	148	ProRestore Products	27, 31-33, 68
Current Tools	51, 54-55	Pullman-Holt Corporation	70-72
Delmhorst Instrument Co.	131-132	Radians, Inc.	183-184, 235
DeWalt®	84, 175-179	Ram Board	261
Dixon Ticondaroga Company	89	Ray-O-Vac Corp. (Spectrum Brands)	11
Dräger Safety, Inc.	126	RIDGID Tool Company	156-166
Dri-Eaz	28, 32, 61, 63, 65, 76, 132	Rubbermaid®	46
Dumond Chemicals, Inc.	35	Rubbermaid Commercial	148
Dwyer Instruments, Inc.	130	Rust-Oleum Company	254-255
Empire Level	82, 84-85, 87	Safeway Sling USA, Inc.	150
Engineering Solutions, Inc.	130	SAS Safety Corp.	211
Enviroguard	219-223, 228, 230-231, 237, 259	Seatek Co. Inc.	60
Ergodyne	209, 236-237	Sensidyne®	128, 218
Ermator LLC	69, 76	Sentinel Products, Inc.	26, 36, 39
Extech® Instruments (a FLIR Company) ..	134	Servus by Honeywell	233
Fiber-Metal® by Honeywell	207-209	Sharpie®	88
Fiberlock Technologies, Inc.	25-26, 34, 37-38, 40	Shop-Vac Corporation	75
Foster® Products (H.B. Fuller Construction Products) ..	28	Showa Best Glove	203-204
Gas Clip Technologies, Inc.	126	Sporicidin® (Contec, Inc.)	30
Gatorade (Pepsico)	46	Sqwincer Corporation, The	47
GB Gardner Bender	49, 52-53, 59	Stanley Tools	91
Generac®	79, 267-269	Touch 'n Seal (Convenience Products) ..	9
Gilmour Group	122-123	TPI Corporation	80
Grayling Industries, Inc.	10, 43	Tractel, Inc.	149, 151
Greenlee®, A Textron Company	48, 56-59, 153-155	Tramex, LTD	133
Grip Rite™ (Prime Source)	261	Tytan International L.L.C.	263
Guard-Line, Inc.	229	Tyvek® (DuPont™)	227, 230-231
H.D. Hudson Manufacturing Company	124	UltraTech International, Inc.	248-253
Herculine®	50	United Abrasives, Inc.	4-7
HexArmor	204	Vaportek, Inc.	67
Howard Leight by Honeywell	210	Viking Equipment	62
Intertape Polymer Group	262-263	WD-40 Company®	39
Irwin Industrial Tool	14-19, 22, 86, 88, 90, 95, 101	Weiler Corporation	8
Justrite Mfg. Co., L.L.C.	151-152	Wright Tool Company	103-114
Kett Tool Company	174	Zefon International	128-129
Klein Tools	92-94, 99-100, 102, 121	ZipWall®, LLC	44-45
Lakeland Industries, Inc.	223-226, 229		
Louisville Ladder	144-145		
LSZ, Inc.	36		
MAX®	9, 31-33, 196, 219, 234, 261		
M.K. Morse Company, The	22		
Maasdam Pow'r Pull	149		
Master Lock®	146-147		

Product Index

(5 Point Harness – Cooling Towels)

5 Point Harness	186	Axe	120	Wire.....	257	Chemicals	25-39
6-Volt Batteries	11	Axial Fan	61	Bucket, Mop/Wringer	141	Chest, Storage	153-154
9-Volt Batteries	11			Plastic	257	Chip Brush	256
		B		Bug Sprayer	124	Chop Saw	179
A		Back Support.....	236	Building Paper.....	261	Chop Saw Wheels.....	5
AA/AAA Batteries	11	Backpack Vacuum	71	Bulb, Flashlight.....	12	Circuit Analyzer	59
Abatement Air Sampling Pump ..	128	Bactericide	27	Bull Pin	105	Circular Saw	170, 174, 177
Abrasive Blades	3	Bags	9-10	Bush Tool	16	Circular Saw Blades	22
Abrasive Wheels	7	Bags, Poly Tubing	78			Clamps.....	101
Abrasives	4-6	Replacement (Vacuum)	74	C		Claw Hammer	115
Absorbents.....	244-247	Trash	138	C Batteries	11	Clay Spade	16
Accessories, Power Tools	23	Ball Pein Hammer	115	Cabinet, Safety	151	Clean Room Mats	259-260
Spray Paint.....	255	Band Saw.....	168, 171, 174, 179	Cabinet, Storage	155	Cleaner	27, 36
Temporary Power	265	Band Saw Blades	23	Cable Choker	192	Cleaner, Disinfectant	25-30
Threading Machine.....	164	Bar, Hex	121	Cable Cutter	52, 60, 102	Cleaner/Degreaser	32-33, 139
Accident Prevention Labels	241	Barricade Tags	243	Cable Dispenser	51	Cleaner/Disinfectant.....	140
Acid Brush.....	257	Barricade Tape	263	Cable Hook (for Ladder)	145	Cleaning Cloths	36
Adapters, Drill Bit.....	16	Barrier System.....	44	Cable Puller	51, 149	Cleaning Pads, Floor	141
Y/GFCI Protection	265	Bathroom Tissue.....	137-138	Cable Pulling Lubricant	52	Respirator.....	218
Impact.....	112-113	Batteries	11	Cables, Lock	146	Cleaning Solution	29
Socket	109	Battery Charger (PAPR)	217	Cable-splicer's Knife	102	Cleaning Station, Lens	180
Vehicle Power	127	Battery Pack (PAPR)	217	Calibration Gas.....	127	Climbing Harness	185
"Y" / "W"	264	Beam Anchor	192	Camera, Infrared	134	Coating, Mold Resistant	26
Adhesive.....	9	Belt, Tool	121	Camp Axe	120	Collection Bags, Vacuum.....	73
Adhesive Gun	171	Bender, Conduit.....	53-54	Can Liners.....	138	Combination Hammer Drill.....	178
Adhesive Labels.....	241	Berm, Spill	251	Can Wrench	121	Combination Square	85
Adhesive Remover	39	Beverage Cooler	46	Canister Vacuum	71	Combination Wrench	103
Adjustable Pipe Support	166	Bi-Focal Safety Glasses.....	184	Cap, Protective	205-209	Combo Kits (Power Tools).....	169, 177
Adjustable Wrench	104	Binder Chain	149	Carabiner	192	Commercial Fan/Blower.....	80
Admittance Signs	238	Bit Holder, 1/4 Hex Shank	19	Carbon Filters	78	Commercial Padlocks	147
Aerosol Disinfectant/Deodorant ..	141	Bits.....	14-15, 17	Cargo Straps	150	Compact Driver	169
Aerosol Dispenser	143	Bits, Core	20	Carpenter Pencil	89	Compliance In A Can	194
Aerosol Paint	254	Hammer Drill	16	Carpenter Square	85	Computer Cases	24
Air Conditioner.....	65	Bladder System, Spill Deck.....	252	Carpet Cleaner	32-33	Concrete Anchor.....	191
Air Filtration.....	76	Blades	20-23	Carpet Deodorizer	32	Concrete Blades	20-21
Air Mover	61-62	Blades, Abrasive	3	Carpet Dryer	61-62	Concrete Moisture Meter	133
Air Sampling.....	128	Band Saw	23	Carpet Protection	259-260	Concrete Saw Blades	21
Air Sampling Cassettes	129	Diamond Concrete.....	21	Carry On Cases	24	Concrete Sprayer.....	124
Air Sampling Pump	128	Razor	258	Cart	51	Conduit Bender	53-54
Air Scrubber	61, 76-77	Utility	90	Cart, Utility	148	Conduit Cutter	157
Air Velocity Meter.....	130	Utility Knife.....	258	Carton Sealing Tape	263	Conduit Fishing	49, 52
Airborne Pathogen Containment ..	40	Bleach	140	Cartridge (PAPR), Respirator.....	217	Conduit Rack	51
Alkaline Batteries	11	Blower	80	Cartridges, Replacement	67	Conduit Screwdriver/Reamer.....	93
Allen Wrench	114	Blue Painters Tape.....	262	Respirator	214	Cone Cup.....	46
All-Purpose Cleaner	33, 140	Bob, Plumb	84	Cases	24	Confined Space.....	195
Aluminum Pipe Wrench.....	156	Body Cleanser	140	CATV Cable Tone Test Kit	59	Confined Space Signs	239
Aluminum Signs	238-240	Boom, Absorbent.....	244-245, 247	Caulk Gun	171	Connectors, Anchorage	192
Anchor Strap	191	Boot Covers	230	Caulk, Silicone.....	258	Hose	123
Anchorage Point	191-192	Boots	233	Caution Tape	263	Constant Flow Regulator	127
Angle Grinder	173, 179	Bottle, Plastic	143	Chain	149	Construction Harness.....	185
Antibacterial Soap	139	Bow Rake.....	119	Chain Rebar Lanyard	189	Construction Line	87
Antimicrobials	25-30	Box Beam Level	86	Chain Vise	166	Construction Sprayer	124
Applicator Gun, Sealant	9	Box Sealing Tape	263	Chalk Reel	88	Construction Wrench	105
Apron.....	231	Box Wrench	104	Charger (PAPR), Battery	217	Containment	40-45
Arbors	18	Box, HazMat.....	148	Chart, Conversion	272	Containment Berms	248
Asbestos Abatement	37-38	Boys Axe.....	120	Equivalent Measures.....	271	Containment for IBCs.....	250
Asbestos Bags	9	Bracket, Headgear.....	180	Nominal Wrench Openings	270	Containment Storage	250
Asbestos PCM Cassette.....	129	Broom	142	Tap Drill Size.....	273	Contractor Lute	119
Asbestos Repair Cloth	37	Brown Jersey Gloves	201	Wattage Consumption	274	Conversion, Fraction/Decimal	272
Asbestos Tape, Danger.....	263	Brush, Acid.....	257	Chemical Protection Coveralls		Temperature	272
Asbestos TEM Cassette	129	Chip	256	222-223, 228	Cooler, Beverage	46
Asphalt Blades	20-21	Cleaning	143	Chemical Protective Clothing		Cooling Headbands	237
Asphalt Cutter	16	Dust / Floor.....	72	224-226	Cooling Inserts, Hard Hat.....	237
Auger Bits.....	17	Foam	256	Chemical Resistant Gloves.....	203-204	Cooling Neckbands	237
Aviation Snips	101	Paint	256	Chemical Signs	238-239	Cooling Towels	237
Awl.....	93	Utility	256				

Product Index

Cooling Vest	237	Disposable Absorbent	245-247	Extraction Accessory	66, 72	Full Facepiece Respirator.....	
Copper Tubing Cutter	169	Disposable Containment	41	Eye & Face Protection.....	180	213, 215, 218
Cord Strapping	50	Disposable Coveralls	219-228	Eye Protection.....	180-184	Fungicide	26-27
Corded Earplugs	210-211	Disposable Cup	46	F		Furniture Block	151
Core Bits	20	Disposable Filter Bags, Vacuum ..	73	Face Protection.....	180	Furniture Polish	140
Corn Fiber Broom	142	Disposable Gloves.....	202, 204	Facepiece Respirator		G	
Cotton Gloves.....	201	Disposable Respirator.....	211-212	212-213, 215, 217	Garage Brush	142
Cotton Mop.....	141	Disposable Towels	36	Faceshield	180	Garden Hose	122
Coveralls	221, 224-227	Disposable Wipes	136-137	Fall Protection	185-195	Gas Can.....	152
Coveralls, Chemical Protection		Ditching Shovel	118	Fan.....	61, 80	Gas Detection	125-127
.....	222-223, 228	Do Not Enter Tape.....	263	Fastener.....	91	Gatorade	46
Flame Resistant.....	228-229	Docking Station (for GasAlert) ..	125	Fastener Drives	19	General Purpose Batteries	11
Microporous	219	Dolly.....	51	Filter	78	General Purpose Cleaner	33
Polypropylene	220	Door Mat	143	Filter (PAPR) Respirator	217	General Purpose Gloves.....	
SMS.....	220	Doorway, Containment.....	45	Filter Bags, Vacuum	73	196-198, 201, 203
Crayon Holder	89	DOT Salvage Drum	251	Filters, HEPA	75	General Purpose Masking Tape ..	262
Crayons, Lumber	89	Drain Seal.....	249	Replacement (Vacuum)	72-74	General Purpose Tape	262-263
Crimped Wire Wheels.....	8	Drain Spade.....	118	Respirator	214-217	Generator	267-269
Crowbar.....	121	Drill	168-173, 175-178	Vacuum	73	Generator Selection Information	
Cup Brushes	8	Drill Bits	14-17	Filters/Cartridges, Respirator.....	214-217	274
Cup Wheel	3	Drill Driver	168, 175	Filtration Coveralls	221	Germicide.....	27
Cup, Disposable.....	46	Drill/Driver	169-170, 177	Filtration, Air.....	77	GFCI Protection Adapters.....	265
Custom-imprint Hard Hat	209	D-Ring Anchor.....	191	Fire & Soot Cleaner.....	33	GFCI Receptacle Tester.....	59
Cut Resistant Gloves ..	198-199, 204	Drink Mix	46-47	Fire Extinguisher Tags	243	GHS Labels	241
Cut Resistant Sleeves.....	202	Drive, Power	160-161	Fire Signs	239	GHS Posters	242
Cutback Adhesive Remover.....	39	Driver, Impact	168	First Aid Kit.....	81	Glass Cleaner.....	33, 140
Cut-Off Tool	176	Drivers, Leather.....	196-197	First Aid Signs.....	239	Glasses, Magnifier	184
Cut-off Wheels	4-5	Dry Vacuum	71	Fish Rod	48	Safety	180-184
Cutter, Cable.....	52, 60, 102	Dryer	61-62	Fish Tape	48	Glo Stix®	48
.....		Dryer, Carpet	61-62	Fish Tape Leader	49	Glovebags	10
Copper Tubing	169	Drywall Saw	90	Fishing, Conduit (Accessories) ..	49, 52	Gloves	196-204
Pipe/Tubing	157	Drywall Screw Gun	178	Fit Test Kit.....	218	Goggles	180
Cutter/Stripper	94	Drywall T-Square	85	Flame Resistant Coveralls ..	228-229	Government Padlock	147
Cutting Wheels	7	Duct Tape	261-262	Flammables Storage	151	Granular Absorbents.....	246
Cylinder Tags	243	Dust Brush, Vacuum	72	Flashlight	11-13	Grease Gun	169
D		Dust Containment	40-45	Flat Chisel	16	Grinder, Angle	173, 179
D Batteries	11	Dust Extraction System	177	Fleece Rags.....	255	Grinding Wheels.....	6-7
Dacron Filter Bags, Vacuum	73	Dust Extractor	69	Flex Duct.....	78	Ground Rod Driver	16
Danger Tape	263	Dust Mop Head	142	Flex Handle Socket Driver.....	109	H	
Data Sheets, Safety.....	242	Dust Mop Treatment	141	Flood Pump.....	65-66	Half Facepiece Respirator ..	213, 215
Datacom Tools.....	121	E		Floodlight	177, 265	Hammer.....	115-116
Debris Bags	9	Ear Protection	210-211	Floor Brush.....	142	Hammer Drill.....	
Debris Containment	194	Earmuffs	210	Floor Brush, Vacuum.....	72	168-170, 172-173, 175-178
Decontamination Shower	43	Earplugs.....	210-211	Floor Dry (Absorbent)	246	Hammer Drill Bits	15-16
Deep Socket.....	110-112, 114	Economy Import Lights.....	265	Floor Fan.....	80	Hammer Drill Driver	
Degreaser/Cleaner	33, 139-140	Electrical Signs.....	239	Floor Protection	259-261	168-170, 172-173, 175-178
Dehumidifier	63-65	Electrical Specialty	48-60	Foam Brush	256	Hammer Drill/Driver	
Demand Flow Regulator	127	Electrician's Scissors.....	102	Foam Cleaner.....	9	168-170, 172-173, 175-178
Demolition Blades	20	Encapsulant, Asbestos.....	38	Foam, Polyurethane.....	9	Hammer, SDS	175, 178
Denim Apron.....	231	Odor.....	31	Fogger.....	68	Hammer/Drill/Driver.....	176
Deodorizer	27, 29, 31-32	Enclosure, Containment	40-43	Form Hammer	116	Hand Protection	196-204
Deodorizer Aerosol	141	Engineer Hammer.....	116	FR Floor Protection	260	Hand Saw	90
Deodorizer/Cleaner	140	Environmental Containment ..	40-42	FR Poly Sheeting.....	167	Hand Soap	139
Desiccant Dehumidifier	64	Equipment	61-79	FR Vest	235	Hand Tools	82-124
Detection, Moisture	131-133	Equipment Signs	240	Fraction/Decimal Conversion ..	272	Handle, Broom	142
Detergent.....	36, 140	Erection Wrench.....	105	Frame, Containment Unit	40	Hard Hat	205-209
Diagonal-Cutting Pliers	100	Ergonomics	236	Framing Square.....	85	Hard Hat Inserts, Cooling	237
Diamond Blades.....	21	Exit Signs.....	238	Freezer Pops	47	Hard Top, Spill Control	250
Diaper Rags.....	255	Extended Run Glovebags.....	10	Full Body Harness	185-186	Hardwood Floor Protection ..	259-260
Diatomaceous Earth	246	Extension Cord	264	Full Brim Hard Hat	205-208	Hardwound Paper Towels ..	136-137
Die Heads.....	158, 165	Extension Ladder.....	145			Harness	185-186
Dishwashing Liquid	140	Extension, Impact.....	112			Hasp	146-147
Disinfectant.....	25-30	106, 109			Hat, Protective	205-209
Disinfectant, Hospital.....	141	External Pump, Gas Detection.....	126			Hatchet	120
Dispenser, Cable.....	51	Extraction	65-66			Haz Mat Absorbent	245-247
.....							
Timed Mist.....	143						

Product Index

(Hazardous Drum Storage – Polypropylene Coveralls)

Hazardous Drum Storage.....	247, 250-251	Hazardous Liquids Coveralls.....	221	Hazardous Materials Signs.....	238-239	Hazardous Waste Containment.....	244-253	Hazmat Boots.....	233	HazMat Box.....	148	Head Light.....	11, 13	Head Protection.....	205-209	Headbands, Cooling.....	237	Header Tags, Blank.....	242	Headgear.....	180	Hearing Protection.....	210-211	Heat Gun.....	174	Heater, PVC.....	54	HEPA Abatement Vacuum.....	75	HEPA Dust Extractor.....	69	HEPA Filter.....	73-75, 78	HEPA Vacuum.....	69-71, 75	Hex Bar.....	121	Hex Bit Sockets.....	107-108, 111	Hex Key Set.....	114	High Visibility Hard Hat.....	205-209	Hi-Viz Apparel.....	234-235	Hi-Viz Safety Vest.....	234-235	Hoist.....	149	Hole Saw.....	18	Hood (PAPR).....	217	Hooded Sweatshirt.....	235	Horizontal Lifeline System.....	193	Hose.....	122	Hose Nozzle/Valve.....	123	Hose, Replacement Vacuum.....	72	Hospital Disinfectant.....	141	Housekeeping Signs.....	240	Humidity Meter.....	133	Humidity Monitor.....	131-132	Hydration.....	46-47	Hydraulic Knockout Set.....	55	Hydraulic Punch.....	58	Hydrogen Peroxide Based Cleaner.....	25	I	IAQ Sampling Pump.....	128	IBC Spill Pallet.....	250	I-Beam Level.....	86	Ice Scraper.....	118	Impact Driver.....	168-170, 175, 177, 112-114	Impact Wrench.....	170, 172, 175	Infrared Camera.....	134	Inlet Manifold.....	78	Insert Bits.....	19	Inspection Tags.....	243	Instant Drink Mix.....	46-47	Instrument, Gas Detection.....	125-127	Instrumentation.....	125-135	Ironworker's Pliers.....	96, 99	Isolation Room.....	42	J	Janitorial Supplies.....	136-143	Jaw Saw.....	90	Jersey Gloves.....	201	Jobber Length Bits.....	14	Joist Drill.....	178	K	Kit, First Aid.....	81	Kitchen Towels.....	136-137	Knee Boots.....	233	Knee Pads.....	236	Knife, Utility.....	90, 258	Knit Rags.....	255	Knockout Punch.....	55-57	Knot Wire Brushes.....	8	L	Labels.....	241-242	Ladder.....	144-145	Ladder Safety System.....	193	Lamp, Flashlight.....	12	Landscape Rake.....	119	Lanyard.....	187-189	Laser Level.....	84	Laser Plumb Bob.....	84	Latex Boot Covers.....	230	Latex Gloves.....	199-200, 202	Latex Rubber Sponge.....	141	Lath Hatchet.....	120	Lead Abatement.....	34-36	Lead Hazard Tape.....	263	Lead Sampling Cassette.....	129	Leader, Fish Tape.....	49	Leaf Rake.....	119	Leather Drivers.....	196-197	Leather Palm Gloves.....	196-198	LED Light.....	11, 13	LED Light Strings.....	265	Lens Cleaning Station.....	180	Lens Cleaning Towels.....	180	Level.....	84, 86-87	Lever Hoist.....	149	Lifeline System.....	193	Lifeline, Rope.....	193	Self Retracting.....	190, 195	Light Strings.....	265	Light, Hands-free.....	11, 13	Portable Work.....	266	Lighting.....	265-266	Lighting Tester.....	135	Line Level.....	87	Lineman's Pliers.....	96-97	Liners, Can.....	138	Liquid Cleaner.....	140	Liquid Concentrate Drink Mix.....	47	Lock.....	146-147	Lock, Hockey Puck.....	146	Locking Pliers.....	95, 101	Locknut Pliers.....	98	Lockout / Tagout Signs.....	239	Lockout Hasp.....	147	Lockout Tags.....	243	Lockout/Tagout.....	147	Long Nose Pliers.....	96, 100	Long Tape.....	83	Lubricant.....	39	Lubricant Remover.....	39	Lubricant, Cable Pulling.....	52	Lumber Crayons.....	89	Luminescent Rod.....	48	M	Machinery Signs.....	240	Magnetic Level.....	86-87	Magnetic Protractor.....	85	Magnifier Glasses.....	184	Maid Broom.....	142	Manhole Ladder.....	145	Manifold, Inlet.....	78	Manometer.....	130	Manual Ratchet Threader.....	158, 165	Marker.....	88-89	Marking Chalk.....	88	Marking Pistol.....	255	Marking Tools.....	89	Marking Wand.....	255	Masking Tape.....	262	Mastic Remover.....	39	Mat, Floor.....	259-260	Material Handling.....	148-155	Mattock, Pick.....	120	MCE Filters.....	129	Measuring Tape.....	82-83	Medical Gloves.....	202	Membranes (for VaporShark).....	67	Mesh Vest.....	234-235	Metal Cutting Blades.....	22	Metal Cutting Saw.....	170, 174	Metal Saw.....	170, 174	Meter, Air Velocity.....	130	Concrete Moisture.....	133	Humidity.....	133	Moisture.....	131-133	Metric Sockets.....	108	Microporous Coveralls.....	219	Missile Line Carrier.....	49	Mixer, Paint.....	257	Moil Point.....	16	Moisture Meter.....	131-133	Moisturizer Soap.....	139	Mold Cleaner.....	25, 28-29	Mold Inhibitor.....	28	Mold Preventer.....	26	Mold Remediation Respirator.....	213	Mold Resistant Chemicals.....	25-26, 28	Monitor, Gas Detection.....	125-127	Moisture.....	131-133	Pressure.....	130	Mop Bucket.....	141	Mop Head.....	141	Mopping Pad.....	141	Multifold Paper Towels.....	136-137	Multi-Gas Detection.....	125-127	Multi-Task Gloves.....	197	N	N95 Particulate Respirator.....	211-212	Narrow Crown Staples.....	91	Neck Shade.....	235	Neckbands, Cooling.....	237	Needle Nose Pliers.....	96, 100	Negative Air Machine.....	76-77	Netting, Debris.....	194	No-Hub Driver.....	168	Nominal Wrench Openings Chart.....	270	Nozzle, Hose Spray.....	123	Nut Driver.....	93-94	Nutsetter, Fractional.....	19	O	Odor Control.....	28, 31-32, 67-68	Odor Control Accessory.....	67	Office (Storage), Field.....	155	Oil Dry Absorbent.....	246	Oil Only Absorbent.....	244-245, 247	Oil, Thread Cutting.....	165	Operations Signs.....	240	Outlet Tester.....	59	Overpack.....	251	Oxygen Detection.....	127	P	Pad Holder.....	142	Pad, Mopping.....	141	Padlock.....	146-147	Pail, Plastic.....	257	Paint Brush.....	256	Paint Mixer.....	257	Paint Remover.....	34-35	Paint Roller Cover.....	256-257	Paint Sock.....	257	Paint Strainer.....	257	Paint Tray / Liner.....	257	Paint, Spray.....	254	Painter's Tape.....	262	Painters Tool, 5-in-1.....	258	Pallet Jack.....	151	Pallet, Spill.....	252	Paper Cup.....	46	Paper Towels.....	136-137	Paper, Building.....	261	Parapet Anchor, Concrete.....	191	Particulate Filter (PAPR).....	217	Particulate Filters.....	214, 216-217	Patch Tape.....	263	PCM Cassette, Asbestos.....	129	PE Film Tape.....	262	Pedestal Fan.....	80	Pencil, Carpenter.....	89	Permanent Marker.....	88-89	Personal Lockout Kit.....	147	Phillips® Head Insert Bits.....	19	Pick Mattock.....	120	Pick, Railroad.....	120	Pictogram Labels.....	241	Pillow, Absorbent.....	244-245, 247	Pipe Cutter.....	157	Pipe Threader.....	160-163	Pipe Vise/Support.....	166	Pipe Wrench.....	156	Pipeline Wheels.....	7	Pistol, Marking.....	255	Plastic Bottle.....	143	Plastic Manifold.....	78	Plastic Signs.....	238-240	Pliers.....	95-101	Plumb Bob.....	84	Plumbing & Mechanical.....	156-166	Pole Grip.....	145	Polish, Furniture.....	140	Poly Sheeting.....	167	Poly Sprayer.....	124	Poly Tubing Bags.....	78	Polyester Strapping Cord.....	50	Polypropylene Coveralls.....	220
-----------------------------	--------------	----------------------------------	-----	--------------------------------	---------	----------------------------------	---------	-------------------	-----	-----------------	-----	-----------------	--------	----------------------	---------	-------------------------	-----	-------------------------	-----	---------------	-----	-------------------------	---------	---------------	-----	------------------	----	----------------------------	----	--------------------------	----	------------------	-----------	------------------	-----------	--------------	-----	----------------------	--------------	------------------	-----	-------------------------------	---------	---------------------	---------	-------------------------	---------	------------	-----	---------------	----	------------------	-----	------------------------	-----	---------------------------------	-----	-----------	-----	------------------------	-----	-------------------------------	----	----------------------------	-----	-------------------------	-----	---------------------	-----	-----------------------	---------	----------------	-------	-----------------------------	----	----------------------	----	--------------------------------------	----	----------	------------------------	-----	-----------------------	-----	-------------------	----	------------------	-----	--------------------	----------------------------	--------------------	---------------	----------------------	-----	---------------------	----	------------------	----	----------------------	-----	------------------------	-------	--------------------------------	---------	----------------------	---------	--------------------------	--------	---------------------	----	----------	--------------------------	---------	--------------	----	--------------------	-----	-------------------------	----	------------------	-----	----------	---------------------	----	---------------------	---------	-----------------	-----	----------------	-----	---------------------	---------	----------------	-----	---------------------	-------	------------------------	---	----------	-------------	---------	-------------	---------	---------------------------	-----	-----------------------	----	---------------------	-----	--------------	---------	------------------	----	----------------------	----	------------------------	-----	-------------------	--------------	--------------------------	-----	-------------------	-----	---------------------	-------	-----------------------	-----	-----------------------------	-----	------------------------	----	----------------	-----	----------------------	---------	--------------------------	---------	----------------	--------	------------------------	-----	----------------------------	-----	---------------------------	-----	------------	-----------	------------------	-----	----------------------	-----	---------------------	-----	----------------------	----------	--------------------	-----	------------------------	--------	--------------------	-----	---------------	---------	----------------------	-----	-----------------	----	-----------------------	-------	------------------	-----	---------------------	-----	-----------------------------------	----	-----------	---------	------------------------	-----	---------------------	---------	---------------------	----	-----------------------------	-----	-------------------	-----	-------------------	-----	---------------------	-----	-----------------------	---------	----------------	----	----------------	----	------------------------	----	-------------------------------	----	---------------------	----	----------------------	----	----------	----------------------	-----	---------------------	-------	--------------------------	----	------------------------	-----	-----------------	-----	---------------------	-----	----------------------	----	----------------	-----	------------------------------	----------	-------------	-------	--------------------	----	---------------------	-----	--------------------	----	-------------------	-----	-------------------	-----	---------------------	----	-----------------	---------	------------------------	---------	--------------------	-----	------------------	-----	---------------------	-------	---------------------	-----	---------------------------------	----	----------------	---------	---------------------------	----	------------------------	----------	----------------	----------	--------------------------	-----	------------------------	-----	---------------	-----	---------------	---------	---------------------	-----	----------------------------	-----	---------------------------	----	-------------------	-----	-----------------	----	---------------------	---------	-----------------------	-----	-------------------	-----------	---------------------	----	---------------------	----	----------------------------------	-----	-------------------------------	-----------	-----------------------------	---------	---------------	---------	---------------	-----	-----------------	-----	---------------	-----	------------------	-----	-----------------------------	---------	--------------------------	---------	------------------------	-----	----------	---------------------------------	---------	---------------------------	----	-----------------	-----	-------------------------	-----	-------------------------	---------	---------------------------	-------	----------------------	-----	--------------------	-----	------------------------------------	-----	-------------------------	-----	-----------------	-------	----------------------------	----	----------	-------------------	------------------	-----------------------------	----	------------------------------	-----	------------------------	-----	-------------------------	--------------	--------------------------	-----	-----------------------	-----	--------------------	----	---------------	-----	-----------------------	-----	----------	-----------------	-----	-------------------	-----	--------------	---------	--------------------	-----	------------------	-----	------------------	-----	--------------------	-------	-------------------------	---------	-----------------	-----	---------------------	-----	-------------------------	-----	-------------------	-----	---------------------	-----	----------------------------	-----	------------------	-----	--------------------	-----	----------------	----	-------------------	---------	----------------------	-----	-------------------------------	-----	--------------------------------	-----	--------------------------	--------------	-----------------	-----	-----------------------------	-----	-------------------	-----	-------------------	----	------------------------	----	-----------------------	-------	---------------------------	-----	---------------------------------	----	-------------------	-----	---------------------	-----	-----------------------	-----	------------------------	--------------	------------------	-----	--------------------	---------	------------------------	-----	------------------	-----	----------------------	---	----------------------	-----	---------------------	-----	-----------------------	----	--------------------	---------	-------------	--------	----------------	----	----------------------------	---------	----------------	-----	------------------------	-----	--------------------	-----	-------------------	-----	-----------------------	----	-------------------------------	----	------------------------------	-----

Product Index

(Polyurethane Foam – Table of Multipliers)

Polyurethane Foam.....9	Ratchet, Power.....168	Safety Tags.....242-243	Smoke Sponge.....141
Pop-Up Shower.....40	Ratchet Knockout Set.....55	Safety T-Shirt.....235	Smoke Test Kit.....218
Portable Air Conditioner.....65	Ratchet Strap Assemblies.....150	Safety Vest.....234-235	Smoking Control Signs.....240
Portable Air Scrubber.....76-77	Ratchet, Socket.....106-114	Safety Wear.....234-237	SMS Coveralls.....220
Portable Containment.....40-45	Spud.....105	Salvage Drum.....251	Snips, Aviation.....101
Portable Dehumidifier.....63-65	Razor Blades.....258	Sampling Pump.....128	Soap.....139
Portable Generator.....267-269	Reading Safety Glasses.....184	San Angelo Bar.....121	Sock, Absorbent.....244-245, 247
Portable Shower.....40, 43	Reamer, Conduit.....93	Sanitizer.....25	Socket Adapter.....19
Portable Vacuum.....66, 69-71	Reaming Screwdriver.....93	Saw Blades.....20-23, 174	Sockets.....106-114
Portable Work Light.....265-266	Receptacle Tester.....59	Saw, Band.....171, 174, 179	Solution, Disinfectant.....30
Positioning Harness.....186	Reciprocating Saw.....168, 173, 175-177, 179	Chop.....179	Soot Cleaner.....33
Positioning Lanyard.....189	Records Tags.....243	Circular.....177	Spacer Sleeves, Vac Filter.....73
Posters, Safety.....242	Reel Pad, Tie Wire.....121	Hand.....90	Spade.....118
Powder Drink Mix.....46-47	Reel Stand.....51	Hole.....18	Spade Bits.....17
Power Block.....264	Reel Tape.....83	Metal.....170, 174	Specialty Filter.....78
Power Cords.....264-265	Reference Charts.....270-274	Reciprocating.....168, 173, 175-177, 179	Speeder, Socket.....106, 109
Power Distribution Center.....264	Regulator, Constant Flow.....127	Sawzall® Blades.....23	Spill Berm.....251
Power Drive.....159	Demand Flow.....127	Scaling Chisel.....16	Spill Control Kits.....247
Power Tape.....82	Reinforced Poly Sheeting.....167	Scissors.....102	Spill Deck.....252
Power Threading Carts.....164	Remover, Paint.....35	Scoop Shovel.....117	Spill Pallet.....252
Power Threading Machine.....160-163	Repair Cloth, Asbestos.....37	Scraper.....118, 258	Spline Bits.....16
Power Tool Accessories.....23	Replacement Bags/Filters (Vacuum).....73-74	Scratch Awl.....93	Sponge.....141
Power Tools.....168-179	Replacement Cartridges, Odor Control.....67	Screw Gun, Drywall.....178	Spray Adhesive.....9
Power Washer.....79	Replacement Membranes, Odor Control.....67	Screwdriver.....92-93	Spray Nozzle.....123
Powered Air Purifying Respirator (PAPR).....217	Replacement Vacuum Filter.....72-74	Scrubbing Strips.....141	Spray Paint.....254
Preservation Tape.....263	Replacement Vacuum Hose.....72	SDS Hammer.....175	Spray Paint Accessories.....255
Pressure Recorder.....130	Rescue System.....193, 195	SDS-Max Bits.....16	Sprayer.....124
Pressure Washer.....79	Respirator Bag.....218	Sealant.....9	Sprayer, Trigger.....143
Primary Filter.....78	Respirator, Disposable.....211-212	Sealant, Asbestos.....37-38	Spud Ratchet.....105
Protection Respiratory.....211-218	Filters/Cartridges.....214, 216-217	Sealed SRL.....190, 195	Square.....84-85
Protection, Eye & Face.....180-184	Full Facepiece.....213, 215, 218	Sealing Tape.....143, 263	Square Drive Socket Adapter.....19
Fall.....185-195	Half Mask.....213, 215	Seal-Off, Compressor.....49	Square Point Shovel.....117
Hand.....196-204	N95 Particulate.....211-212	Secondary Filter.....78	Squeegee.....142
Head.....205-209	Respiratory Protection.....211-218	Segmented Diamond Blades.....21	Sqwincher.....47
Hearing.....210-211	Ring Panel Filter.....78	Self Retracting Lifeline.....187-188, 190, 195	SRL.....187-188, 190, 195
Respiratory.....211-218	Rip Claw Hammer.....115	Self-adhesive Zipper.....45	Standard Socket.....110-113
Protective Clothing.....219-231	Roll Towels.....136-137	Service Status Tags.....243	Staple Gun.....91
Protractor.....85	Roller Cover, Refill.....256-257	Shackleless Padlock.....146	Staples.....91
Pry Bar.....121	Roof Shovel.....118	Shampoo.....140	Station, First Aid.....81
Pulling Tape.....50	Roof Top Anchor.....191	Shear.....174	Stem-Mounted Brushes.....8
Pumice Hand Cleaner.....139	Rope Grab.....193	Shear, PVC.....169	Step Drill Bits.....17
Pump for Gas Detection, External.....126	Rope Lifeline.....193	Shock Absorbing Lanyard.....187-189	Stepladder.....144
Tube.....126	Rotary Hammer.....170, 172-173, 176-177	Shoe Covers.....230	Storage Cabinet.....155
Pump, Air Sampling.....128	Rotary Hammer, SDS.....176	Shop-Vac.....75	Storage Chest.....153-154
Flood.....66	Round Point Shovel.....117	Shovel.....117-118	Stormwater Compliance.....253
Hydraulic (for Punch).....58	Rubber Gloves.....199-200, 202	Shower, Portable.....40, 43	Straight Edge.....85
Sampling.....128	Rubber Hose.....122	Side-Cutting Pliers.....99	Straight Pipe Wrench.....156
Siphon.....143	Sack Pillow, Absorbent.....244-245, 247	Signs.....238-240	Strainer, Paint.....257
Two-stage Shower.....43	Safety Boots.....233	Silicone Caulk.....258	Strap Wrench.....156
Purification, Air.....77	Safety Cabinet.....151	Silicone, Economy.....143	Strapping Cord.....50
Putty Knife.....258	Safety Can.....152	Single Gas Detection.....125-127	Straps, Ratchet.....150
PVC Heater.....54	Safety Data Sheets.....242	Single Glovebags.....10	Stripper, Paint.....35
PVC Shear.....169	Safety Glasses.....181-184	Siphon Pump.....143	Wire.....52
Q	Safety Goggles.....180	Sledge Hammer.....116	Stripper/Cutter.....94
Quick Twist Glovebags.....10	Safety Incentive Signs.....240	Sleeves, Protective.....202, 204, 231	Stripping Pads, Floor.....141
R	Safety Lockout Hasp.....147	Sling, Polyester Web.....150	Stud Drill.....178
Ratchet Threader.....158, 165	Safety Signs.....238-240	Slips, Trips & Falls Signs.....240	Sundries.....255-258
Rafter Square.....85	Safety Sweatshirt.....235	Slotted Insert Bits.....19	Support, Back.....236
Rags.....255		Slug-Buster®.....56-58	Supported Gloves.....200, 203
Railroad Pick.....120		Slug-Splitter®.....58	Surface Protection.....259-261
Rainsuit.....232		Smoke & Soot Cleaner.....33	Surveyor Vest.....234-235
Rainwear & Boots.....232-233		Smoke Deodorizer.....31	Sweatshirt, Safety.....235
Rake.....119		Smoke Odor Solution.....67	T

(Tags – Zipper, Self-adhesive)

Tags.....	242-243	Twine	87	Winter Liner, Head.....	209
Tap Drill Size Chart.....	273	Two-stage Shower Pump.....	43	Wiper Mat.....	143
Tape	261-263	U			
Tape Measure.....	82-83	Uncorded Earplugs.....	210-211	Wipes.....	30, 136-137, 218
Tape, Barricade.....	263	Universal Joint, Impact.....	112-113	Wipes, Disinfectant.....	30
Pulling.....	50	Unsupported Gloves.....	199-200	Respirator.....	218
Sealing.....	143	Utility Bar.....	121	Wire Brush.....	143, 257
Tapping Tool.....	93	Utility Blades.....	90	Wire Cutter.....	95
Telecom Tools.....	121	Utility Brush.....	256	Wire Stripper/Cutter.....	52, 94
TEM Cassette, Asbestos.....	129	Utility Cart.....	148	Wire Testing/Tracing.....	59
Temperature Conversion.....	272	Utility Grade Masking Tape.....	262	Wire Wheels/Brushes.....	8
Temporary Power.....	264-269	Utility Knife.....	90, 258	Wiring Devices.....	265
Temporary Power Accessories.....	265	Utility Knife Blades.....	90, 258	Work Gloves.....	196-201, 203-204
Terry Cloth Rags.....	255	Utility Level.....	87	Work Light.....	265-266
Test Instruments, Electrical.....	59	Utility Tray.....	253	Wrecking Bar.....	121
Test Kit, Fit (Respirator).....	218	V			
Test Kit, Smoke.....	218	V Head Pipe Stand.....	166	Wrench.....	103-105, 156
Testing, Wire.....	59	Vacuum.....	66, 69-71, 74-75	Wrench, Hex.....	114
Thermal Imaging.....	134-135	Vacuum Accessory.....	72-75	Wrist Wrap.....	236
Thermo-Hygrometer.....	131-133	Vacuum Monitor.....	130	X	
Thread Cutting Oil.....	165	Vacuum Saw.....	174	Xenon Bulb.....	12
Threading.....	158-159, 165	Valve Assembly (for Fishing Systems).....	49	Y	
Threading Machine.....	160-163	Valve, Hose.....	123	“Y” Adapter.....	264-265
Threading Machine Accessories.....	164	Vehicle Power Adapter (for Gas Monitors).....	127	Z	
Threading, Power.....	159-161	Ventilation, Air.....	61	Zipper.....	44
Tie-Wire Reel.....	121	Vermiculite.....	246	Zipper, Self-adhesive.....	45
Tie-Wire Reel Pad.....	121	Vertical Lifeline Systems.....	193		
Tilt Truck.....	148	Vertical Net.....	194		
Tissue, Bathroom.....	137-138	Vest, Cooling.....	237		
Toilet Tissue.....	138	Safety.....	234-235		
Tone & Probe Kit.....	59	Vest-Style Harness.....	185		
Tongue and Groove Pliers.....	97-98	Vinyl Coated Gloves.....	200		
Tool Belt.....	121	Vinyl Hose.....	122		
Tool Box.....	153-154	Vinyl Labels.....	241		
Tool Kit, Vacuum.....	72	Vinyl Signs.....	238-240		
Tools, Power.....	168-179	Vise Grips.....	95		
Torpedo Level.....	86-87	W			
Torque Wrench.....	110	“W” Adapter.....	264		
Towelettes, Respirator Cleaning.....	218	Wallet Cards, GHS.....	241		
Towels.....	255	Wand, Flood Pump.....	66		
Towels, Absorbent.....	244-245, 247	Marking.....	255		
Cooling.....	237	Vacuum.....	72		
Disposable.....	36	Washer, Power.....	79		
Hand Cleaner.....	139	Water Cooler.....	46		
Lens Cleaning.....	180	Water Extraction.....	65-66		
Paper.....	136-137	Wattage Consumption Chart.....	274		
Tracing, Wire.....	59	WD-40®.....	39		
Trash Bags.....	138	Web Sling.....	150		
Trauma Strap.....	194	Web SRL.....	190		
Trenching Ladder.....	145	Wedge Anchor.....	191		
Trenching Shovel.....	118	Weed Sprayer.....	124		
Trigger Sprayer.....	143	Welders Gloves.....	201		
Tripod, Aluminum.....	195	Welding Attachment, Respirator.....	215		
Trolley Anchor.....	192	215		
Truck, Pallet.....	151	Welding Clamps.....	101		
T-Shirt, Safety.....	235	Wet/Dry Vacuum.....	69-70, 74-75		
T-Square.....	85	Wetting Agent.....	38		
Tube Pump, Gas Detection.....	126	Wheel Base, Containment Unit.....	40		
Tubing Cutter.....	157	Wheelbarrow.....	148		
Turbo Blades.....	21	Whisk Broom.....	142		
Turbo Rim Diamond Blades.....	21	Wide Scaling Chisel.....	16		
Turkish Towel Rags.....	255	Winch.....	149		
Turtle Cart.....	51	Winch, Retrieval.....	195		
Twin Front Ladder.....	144				



EXPERIENCE THE DIFFERENCE



Abatix Supply Advantage Program – A.S.A.P.

What if you could reduce supply costs and improve productivity? With a customized Abatix A.S.A.P. On-site Vending solution powered by AutoCrib, you can.

AutoCrib delivers the world's broadest line of automated inventory vending systems (software and machines) for manufacturing companies, airlines, military, retailers, distributors and others who want to provide 24/7 unmanned access to inventory while maintaining complete access control and 100% inventory accuracy. AutoCrib has been providing industrial vending solutions since 1995 and has deployed over 15,000 systems worldwide.

Benefits of A.S.A.P. On-site Vending

- Reduces consumption by controlling waste, fraud/theft and abuse.
- Reduces inventory carrying costs by reducing the inventory needed to run your operation.
- Reduces obsolete inventory by increasing visibility of slow and dead inventory.
- Reduces/eliminates stock-outs by cutting spend on unnecessary overnight shipments and duplicate tools and supplies.
- Makes tools and supplies more available at point of use for your employees.
- Makes tools and supplies accessible 24/7 without adding to staff.
- Puts a complete record of tools, supplies, and costs used on every job at your fingertips.
- Supports initiatives in Lean manufacturing, Six Sigma, ISO, OSHA, Sarbanes Oxley, ROA, asset management and stock-out reduction.



Contact us for more info: 888-222-8489 or autocrib@abatix.com



JACKSONVILLE, FL • LOS ANGELES, CA • PHOENIX, AZ

Abatix Learning Centers provide a variety of OSHA training, industry certification and continuing education classes for customers, professionals, industry groups and associations within the industries we serve.

Spreading the Knowledge – Abatix Learning Centers offer a variety certification classes regulated by both governmental and industry related groups, such as OSHA, EPA, Licensing groups (IICRC, IAQA, Maritime, and Construction), as well as product demonstrations and general industry informational sessions.

Need a product demonstration, product training or a location for an industry meeting? Please contact us, we will be happy to support your needs.

Abatix has aligned itself with reputable industry training providers to bring high quality training classes and instructors to those who wish to receive the best possible learning experience.



To learn more about Abatix Learning Centers and to view a current schedule of training courses in our Jacksonville, FL, Los Angeles, CA and Phoenix, AZ Learning Centers, please visit us at www.abatix.com and click on the Learning Center link.

Toll Free: 888-222-8499

www.abatix.com



Locations

Headquarters
2400 Skyline Dr., Suite 400
Mesquite, TX 75149
Toll Free: 888-222-8499
Fax: 214-381-9513

Atlanta Branch
415 Horizon Dr., Bldg 300, Suite 300
Suwanee, GA 30024
Phone: 877-670-7028
Fax: 404-381-1472

Dallas Branch
2400 Skyline Dr., Suite 400
Mesquite, TX 75149
Phone: 800-426-3983
Fax: 214-388-0443

Houston Branch
7170 West 43rd St., Suite 200
Houston, TX 77092
Phone: 800-542-6296
Fax: 713-956-1350

Jacksonville Branch
6500 Bowden Road, Building 300, Suite 307
Jacksonville, FL, 32216
Phone: 800-998-2116
Fax: 904-296-3940

Las Vegas Branch
5530 Arville St., Suite D
Las Vegas, NV 89118
Phone: 866-333-6826
Fax: 702-795-0190

Los Angeles Branch
10051 Painter Ave.
Santa Fe Springs, CA 90670
Phone: 800-952-2284
Fax: 562-946-1855

Phoenix Branch
3011 East Broadway, Suite 300
Phoenix, AZ 85040
Phone: 800-889-5186
Fax: 602-323-1942

San Antonio Branch
610 Lanark Drive, Suite 203A
San Antonio, TX 78218
Phone: 877-617-8310
FAX: 210-775-1490

San Diego Branch
6490 Marindustry Place, Suite E
San Diego, CA 92121
Phone: 800-952-2284
Fax: 858-201-4413

San Francisco Branch
14068 Catalina St.
San Leandro, CA 94577
Phone: 800-365-5795
Fax: 510-614-2350

Seattle Branch
1808 B St. NW, Suite 190
Auburn, WA 98001
Phone: 800-500-8355
Fax: 253-735-1932

www.abatix.com