



POWER SERIES

Contractor 1000™

Submittal Sheet

This model offers the following features and benefits:

- 1 HP long-lasting, Dura-Drive® Induction motor
- Reduced Sound featuring a reduced noise level over a standard disposal
- Power Grind for tough food scraps
- 2-Stage MultiGrind® Technology: Finer grind designed to prevent clogs
- EZ Connect Disposal easily connects to a hardwire connection or outlet
- Removable, Dishwasher Safe Antimicrobial Baffle
- Safe for use with properly maintained septic tanks
- Units Available: Contractor 1000™ with EZ Connect Adapter or Contractor 1000™ with EZ Connect Cord

Specifications

Type of Feed	Continuous
On/Off Control	Wall Switch
Motor	Single Phase
HP	1
Volts	120
HZ	60
RPM	1725
Amp. (Avg. Load)	10.2
Time Rating	Intermittent
Lubrication	Permanently Lubricated Upper & Lower Bearings
Shipping Weight (Approx.)	18.9, 19.1
Overall Height	12
Motor Protection	Automatic Reset
Average Water Usage	Approx. 1 Gallon per Person Per Day
Average Electrical Usage	3-4 KWH per Year
Drain Connection	1-1/2" Cushioned Slip Joint
Dishwasher Drain Connection	Yes

Dimensions

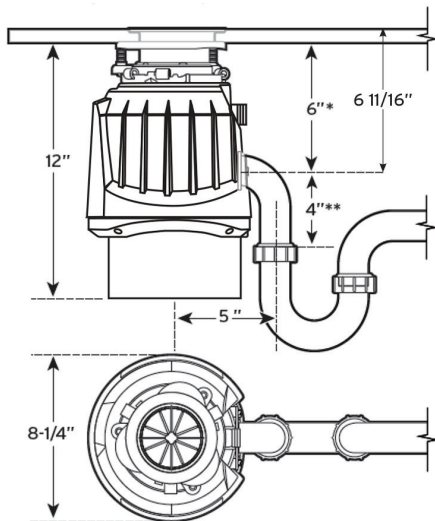

Sample Specification

Food Waste Disposer(s) shall be InSinkErator Contractor 1000™, continuous feed, with 1 HP. motor, stainless steel grinding elements with two stainless steel 360° swivel lugs. Exclusive self-service wrench.

Warranty

8-Year We Come to You® Limited In Home Warranty

* The complete InSinkErator warranty is included in the Care & Use Booklet packed with each unit.



Food waste is roughly 80% water. By using your disposal regularly, you can help divert food waste from landfills and reduce greenhouse gas emissions. Make sustainability a family affair by using your disposal. After all, the smallest changes can make the biggest impact.

Job Specifications



1-800-558-5700
www.insinkerator.com