

LED Fixed Rail Luminaires

Model #: CARF, CRRF, CRRF AND TRRF4200LED

Surface Mount

120VAC / 60Hz

Safety Precautions

Read all safety precautions and installation instructions carefully before installing or servicing this fixture. Failure to comply with these instructions could result in potentially fatal electric shock and/or property damage.

It is recommended that a qualified electrician perform all wiring. This fixture must be wired in accordance with all national and local electrical codes.

Do not handle any energized fixture or attempt to energize any fixture with wet hands or while standing on a wet or damp surface or in water.

This fixture is designed for use in a 110-120VAC, 60Hz fused circuit and can be used in conjunction with *most* 2-wire, triac dimmers.

To reduce the risk of electrical shock, and to assure proper operation, this fixture must be adequately grounded. To accomplish proper grounding, there must be a separate ground wire (green) contact between this fixture and the ground connection of your main power supply panel.

This fixture is intended to be used for general indoor lighting in dry or damp locations only.

ASSEMBLY INSTRUCTIONS

Step 1. Preparing for installation

A. **Disconnect electrical power** at fuse or circuit breaker box before installing or servicing any part of this fixture.

B. Carefully remove the fixture from the carton.

Step 2. Remove circular gem bar from the fixture base by removing two screws.

Wiring—all wiring must take place inside junction box (not included)

Caution: Make sure power is off at fuse or circuit breaker box. Check power wires for damage or scrapes. If power supply wires are within three inches of the ballast power supply, use wire suitable for at least 90C (194F).

Note: Most dwellings built before 1985 have supply wire rated to 60C. Consult a qualified electrician before installing.

Step 3. Install circular gem bar (supplied) on the junction box (not supplied) by securing it with two screws (supplied).

Step 4.

A. Make all wire connections to appropriate wire. Secure with wire nuts (supplied).

B. Connect the green wire from the fixture to the power source green wire.

C. The black wire from the fixture is connected to the black (L) wire from power source.

D. The white wire from the fixture is connected to the white (N) wire from power source.

E. Tuck all connections neatly into the junction box.

Step 5. Place fixture base over the gem bar, align two mounting holes on both sides.

Step 6. Install fixture by securing the base with two screws (supplied).

Restore power at fuse or circuit breaker box.

For Relamping only

Step 7. Insert new LED lamp into the lamp holder and turn it counter clockwise until lamp snaps in place.

Step 8. Thread in the lamp cover.

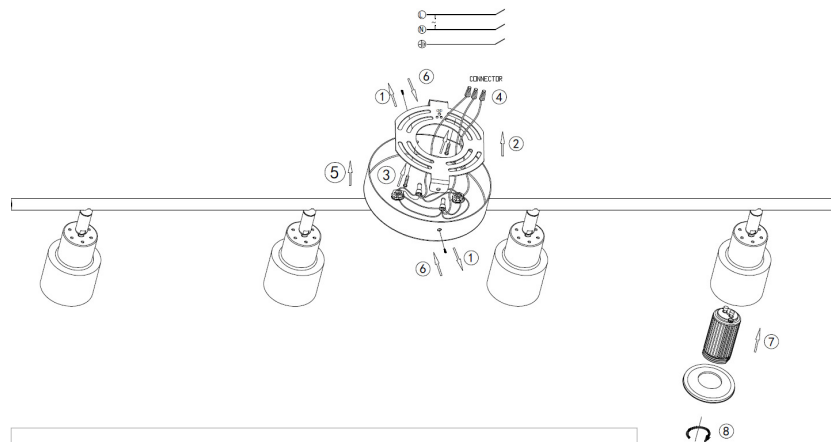

Limited Factory Warranty

AFX warrants this fixture is free from defects in materials and workmanship when installed and used under normal operating conditions for a period of 3 years from date of purchase. This warranty covers all component parts and extends only to replacement of defective fixture or components; it does not cover failure due to improper installation, misuse, mishandling or damage incurred in transit