



# SERVICE PARTS LIST

**BULLETIN NO.  
54-40-1921**

SPECIFY CATALOG NO. AND SERIAL NO. WHEN ORDERING PARTS		REVISED BULLETIN	DATE
<b>7-1/4" Worm Drive Saw</b>		54-40-1920	Aug. 2011
<b>CATALOG NO. 6477-20</b>	STARTING SERIAL NUMBER <b>B20B</b>	WIRING INSTRUCTION <b>58-01-0355</b>	

00 0

**EXAMPLE:**

Component Parts (Small #) Are Included  
When Ordering The Assembly (Large #).

★ = Part number change from  
previous service parts list.

FIG.	PART NO.	DESCRIPTION OF PART	NO. REQ.	FIG.	PART NO.	DESCRIPTION OF PART	NO. REQ.
1	02-04-2805	Bearing	1	68	36-18-0595	Spindle	1
2	02-04-2810	Bearing	1	69	40-50-0045	Guard Spring	1
3	02-04-2815	Bearing	1	70	40-50-8305	Wave Spring	1
4	02-04-2820	Bearing	1	71	40-50-8315	Wave Spring	1
5	02-04-2825	Bearing	1	72	40-50-8345	Compression Spring	1
6	05-59-0130	Domed Nut, 5/16-18 UNC	1	73	40-50-8365	Compression Spring	1
7	05-59-0135	Domed Nut, 5/16-18 UNC	1	74	40-50-8370	Compression Spring	1
8	05-70-0335	Screw, Torx, T30, M8 x 40 mm	1	75	42-14-0465	Rubber Bladder	1
9	05-74-0010	Screw, Torx, T20, M4 x 16	4	76	42-36-2170	C-Channel Depth Bracket	1
10	05-74-0900	Screw, Torx, T10, M3 x 10 mm	6	77	42-36-2175	Depth Lever Bracket	1
11	05-74-0905	Screw, Torx, T20, M5 x 20 mm	7	78	42-38-0225	Rubber Bumper	1
12	05-74-0910	Screw, Torx, T25, M5 x 108 mm	1	79	42-40-0090	Bushing	1
13	05-74-0915	Screw, Torx, T25, M5 x 95 mm	3	80	42-40-1005	Lockout Bushing	1
14	05-74-0925	Screw, Torx, T20, 6-19 x 5/8	2	81	42-52-1020	Spindle Lock Cap	1
15	05-74-0930	Screw, Cross Drive, M3.5 x 12 mm	4	82	42-52-1050	Oil Fill Cap	1
16	05-74-0935	Screw, Torx, T25, M5 x 15 mm	2	84	42-68-0605	Cord Clamp	1
17	05-74-0940	Set Screw, Torx, T20, M6 x 8 mm	2	85	42-70-0140	E-Clip	2
18	05-74-0950	Screw, Torx, T20, M3 x 5 mm	1	86	42-92-1535	Cover Bladder	1
19	05-74-0955	Screw, Torx, T25, M5 x 6 mm x 9.5 mm	6	87	43-34-0275	Inner Blade Flange	1
20	05-74-0960	Field Screw, Torx, T25, M5 x 50 mm	2	88	43-34-0285	Outer Blade Flange	1
22	05-74-1005	Screw, Torx, T25, M6 x 10 mm	7	★ 89	43-50-0120	Inner Oil Glass	1
23	05-74-0975	Screw, Torx, T20, M5 x 15 mm	1	90	43-50-0110	Outer Oil Glass	1
24	05-78-0305	Screw, Slotted Torx, Metric	4	91	43-50-0115	Blade Spring Washer	1
25	05-84-0980	Set Screw, M6 x 8 mm	1	92	43-70-0025	Hinge Pin	1
26	05-86-0200	Screw, Torx, T20, M5 x 11 mm	2	93	43-74-0055	Rafter Hook	1
27	05-90-0003	Spring Lock Washer	6	94	43-74-0095	Mount Hook	1
28	05-90-0160	Lock Washer	1	95	43-78-0580	Lower Guard Hub	1
29	05-90-0195	Lock Washer	9	96	43-96-0240	Woodruff Key	1
30	06-10-3195	Carriage Bolt, 5/16-18 x 3/4	1	97	43-98-0550	Edge Guide Lock	1
31	06-57-0050	Hex Nut, M6	1	98	44-10-0420	Guard Lever	1
32	06-65-0100	Lock Pin	1	99	44-20-0830	Spindle Lock Disc	1
33	06-75-0175	Blade Screw, 3/8-16 x 19 mm, LH Thread	1	100	44-60-1145	Spring Pin	1
34	06-83-0900	Screw, 5/16-18 x 1-1/8	1	101	44-60-1155	Bevel Pin	1
35	10-15-0312	Spanish Warning Label	1	102	44-68-0670	Rubber Plug	4
36	10-15-0313	French Warning Label	1	103	44-76-0050	Strain Relief	1
38	12-20-0631	Nameplate	1	104	45-06-0107	Oil Seal	1
39	14-74-0100	Bevel Lever Assembly	1	105	45-06-0285	Oil Seal	1
40	14-74-0245	Shoe	1	106	45-06-0295	Washer	1
41	16-70-0173	Armature	1	107	45-06-0296	O-Ring	1
42	18-70-0143	Field	1	108	45-12-0030	Oil Shield Washer	1
43	22-18-0134	Brush Tube Assembly	2	109	45-22-0605	Lower Guard Sleeve	1
44	22-18-0148	Brush Assembly	2	110	45-22-0390	Bumper Sleeve	1
45	22-32-0320	Brush Cap	2	111	45-88-0010	Flat Washer	2
47	22-64-1104	Cord (Double Insulated)	1	112	45-88-1385	Bevel Cap	1
48	23-39-0205	External Retaining Ring	1	113	45-88-1390	Washer	1
49	23-66-1812	Switch	1	114	45-88-1395	Washer	2
50	25-16-0105	Bevel Bracket	1	115	45-88-7465	O-Ring	1
51	25-16-0125	Elevation Bracket	1	116	45-88-7480	Washer	1
52	28-41-0725	Upper Guard	1	117	45-96-0280	Blade Wrench	1
53	28-41-0730	Lower Guard	1	118	31-53-0105	Rubber Slug	1
★ 54	28-14-6477	Machined Gear Case	1		49-32-0050	Oil, 8 Oz. (Not Shown)	1
55	28-50-0575	Motor Housing	1		42-41-4119	7-1/4" Circle Saw Blade (Not Shown)	1
56	31-44-0670	Heat Shield	1		48-55-1101	Steel Carrying Case (Not Shown)	1
57	31-44-0675	Bale Handle	1				
58	31-44-1107	LH Handle	1				
59	31-44-1108	RH Handle	1				
60	31-50-0190	Motor Sleeve	1				
61	32-90-0112	Worm Gear	1				
62	32-91-0120	Worm Gear Pinion	1				
63	34-40-1555	O-Ring	1				
64	34-40-1560	O-Ring	1				
65	34-80-2955	Retaining Ring, 32 mm	2				
66	34-80-2965	Retaining Ring, 17 mm	1				
67	34-80-2975	Retaining Ring, 40 mm	1				

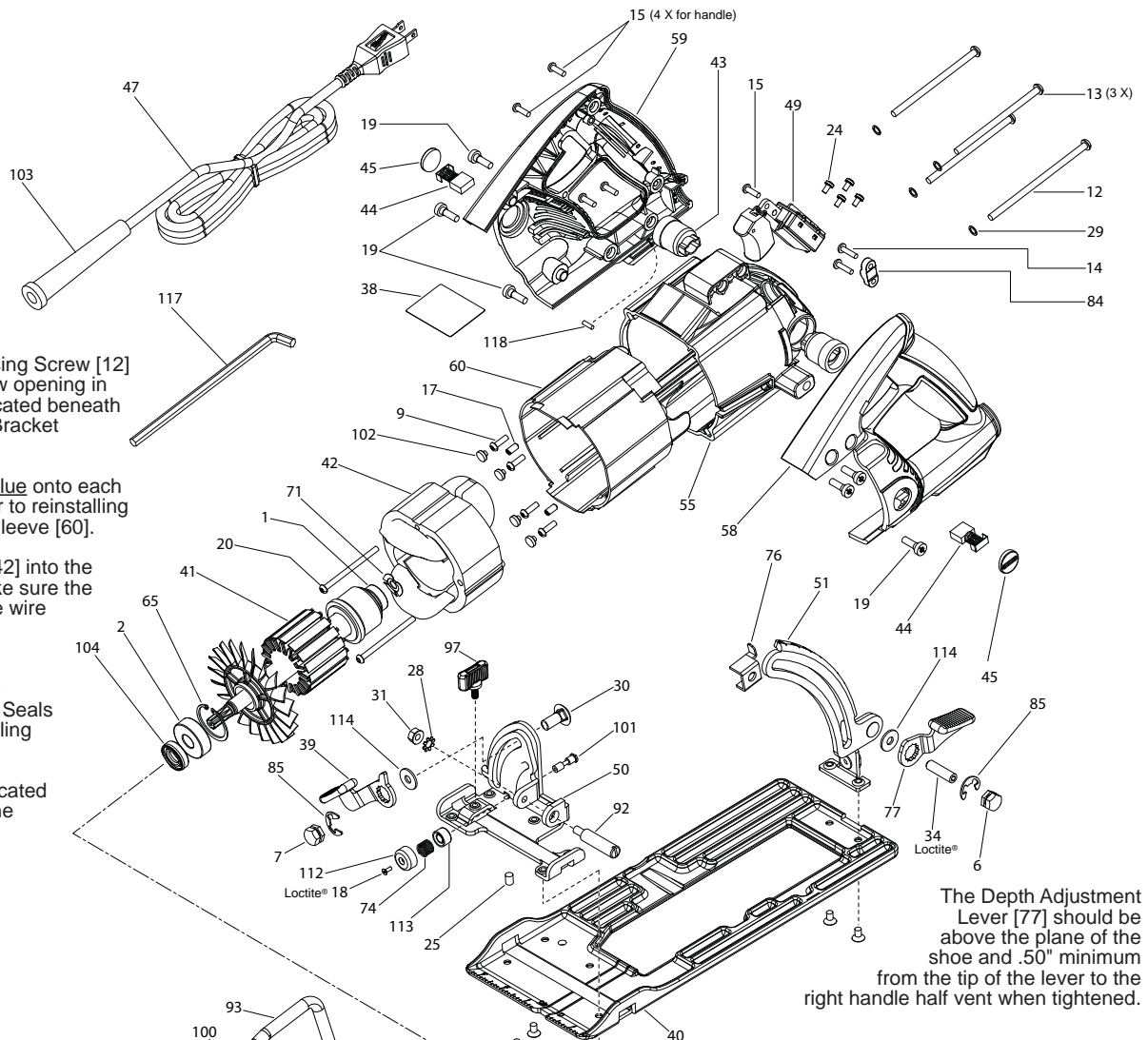

Install long Motor Housing Screw [12] (108mm) through screw opening in Motor Housing [55], located beneath the C-Channel Depth Bracket stud [76].

Place a drop of white glue onto each Rubber Plug [102] prior to reinstalling into pockets of Motor Sleeve [60].

When installing Field [42] into the Motor Sleeve [60], make sure the white field lead is in the wire trap before securing Field Screws [20].

Lubricate inside lip and outside diameter of Oil Seals [104,105] prior to installing into Gear Case [54].

Rubber Slug [118] is located in the bottom area of the handle halves. Place a drop of glue or RTV to secure in place.

The Depth Adjustment Lever [77] should be above the plane of the shoe and .50" minimum from the tip of the lever to the right handle half vent when tightened.

**NOTE:** For item #22, some earlier tools may have used 05-74-0970 (M5 x 10 Flat Hd. T-20 screw). A drop of "Blue" Loctite, Type 242 is needed on the threads.

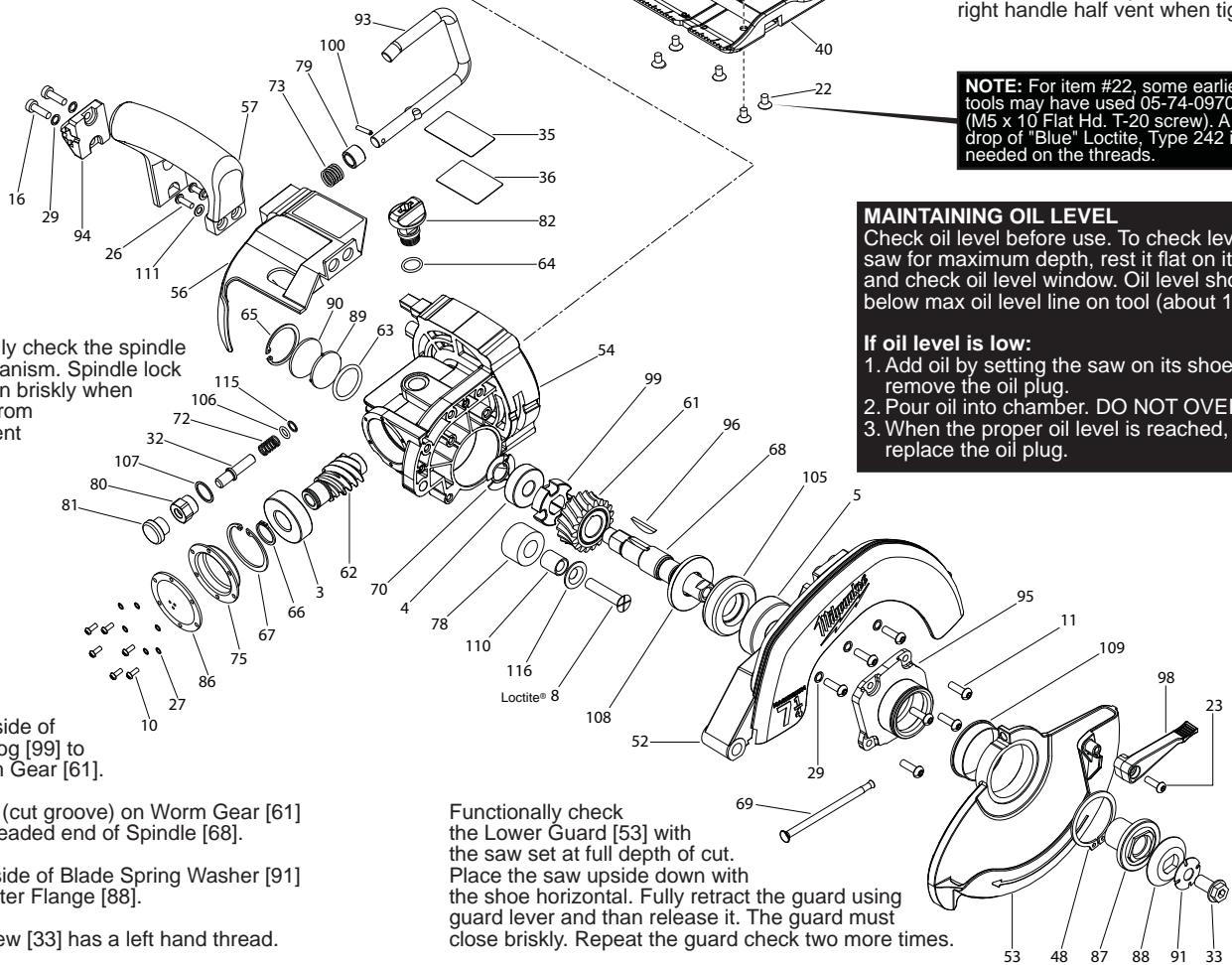

Functionally check the spindle lock mechanism. Spindle lock must return briskly when released from engagement in gear.

Shoulder side of Locking Cog [99] to face Worm Gear [61].

Recessed (cut groove) on Worm Gear [61] to face threaded end of Spindle [68].

Concave side of Blade Spring Washer [91] to face Outer Flange [88].

Blade Screw [33] has a left hand thread.

Functionally check the Lower Guard [53] with the saw set at full depth of cut. Place the saw upside down with the shoe horizontal. Fully retract the guard using guard lever and then release it. The guard must close briskly. Repeat the guard check two more times.

**MAINTAINING OIL LEVEL**  
 Check oil level before use. To check level, set saw for maximum depth, rest it flat on its shoe and check oil level window. Oil level should be below max oil level line on tool (about 1/2 oz.).

**If oil level is low:**

1. Add oil by setting the saw on its shoe and remove the oil plug.
2. Pour oil into chamber. **DO NOT OVER FILL.**
3. When the proper oil level is reached, replace the oil plug.