

RAPID RESPONSE Series LFII Residential 4.9 K-factor Pendent Sprinkler Wet Pipe Systems

General Description

TYCO RAPID RESPONSE Series LFII Residential 4.9K Pendent and Recessed Pendent Sprinklers (TY2236) are decorative, fast response, frangible bulb sprinklers designed for use in residential occupancies such as homes, apartments, dormitories, and hotels. When aesthetics and optimized flow characteristics are the major consideration, the Series LFII Residential Sprinklers (TY2236) should be the first choice.

The Series LFII Residential Sprinklers are intended for use in the following scenarios:

- wet pipe residential sprinkler systems for one- and two-family dwellings and mobile homes per NFPA 13D
- wet pipe residential sprinkler systems for residential occupancies up to and including four stories in height per NFPA 13R
- wet pipe sprinkler systems for the residential portions of any occupancy per NFPA 13

The recessed version of the Series LFII Residential Sprinklers is intended for use in areas with finished ceilings when used with one of the following:

- A two-piece Style 15 Recessed Escutcheon with recessed adjustment up to 5/8 in. (15,9 mm) from the flush pendent position.

IMPORTANT

Refer to Technical Data Sheet TFP2300 for warnings pertaining to regulatory and health information.

Always refer to Technical Data Sheet TFP700 for the "INSTALLER WARNING" that provides cautions with respect to handling and installation of sprinkler systems and components. Improper handling and installation can permanently damage a sprinkler system or its components and cause the sprinkler to fail to operate in a fire situation or cause it to operate prematurely.

- A two-piece Style 20 Recessed Escutcheon with recessed adjustment up to 1/2 in. (12,7 mm) from the flush pendent position.

The adjustment provided by either Recessed Escutcheon reduces the accuracy to which the pipe drops to the sprinklers must be cut.

The Series LFII Residential Sprinklers have been designed with heat sensitivity and water distribution characteristics proven to help in the control of residential fires and to improve the chance for occupants to escape or be evacuated.

Corrosion-resistant coatings, where applicable, are utilized to extend the life of copper alloy sprinklers beyond that which would otherwise be obtained when exposed to corrosive atmospheres. Although corrosion-resistant coated sprinklers have passed the standard corrosion tests of the applicable Approval agencies, the testing is not representative of all possible corrosive atmospheres. Consequently, it is recommended that the end user be consulted with respect to the suitability of these coatings for any given corrosive environment. The effects of ambient temperature, concentration of chemicals, and gas/chemical velocity should be considered, as a minimum, along with the corrosive nature of the chemical to which the sprinklers will be exposed.

NOTICE

The Series LFII Residential Pendent and Recessed Pendent Sprinklers (TY2236) described herein must be installed and maintained in compliance with this document and the applicable standards of the NATIONAL FIRE PROTECTION ASSOCIATION (NFPA), in addition to the standards of any authorities having jurisdiction. Failure to do so may impair the performance of these devices.

The owner is responsible for maintaining their fire protection system and devices in proper operating condition. Contact the installing contractor or product manufacturer with any questions.



Sprinkler Identification Number (SIN)

TY2236

TY2236 is a replacement for the TY2234.

Technical Data

Approvals

UL and C-UL Listed

Certified to all requirements of NSF/ANSI 61

Note: Sprinklers with a polyester finish are UL Listed as corrosion-resistant sprinklers.

See the Design Criteria section for details on these approvals.

Maximum Working Pressure

175 psi (12,1 bar)

Discharge Coefficient

K=4.9 gpm/psi^{1/2} (70,6 lpm/bar^{1/2})

Temperature Rating

155°F (68°C) or 175°F (79°C)

Finishes

Natural Brass, Pure White Polyester Coated, Signal White Polyester Coated, or Chrome Plated

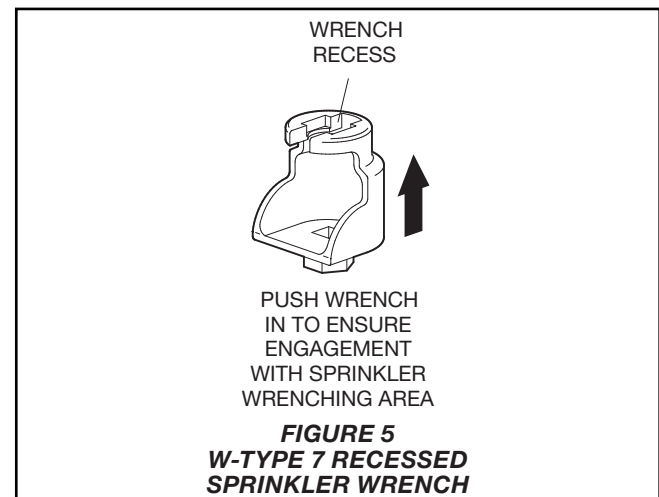
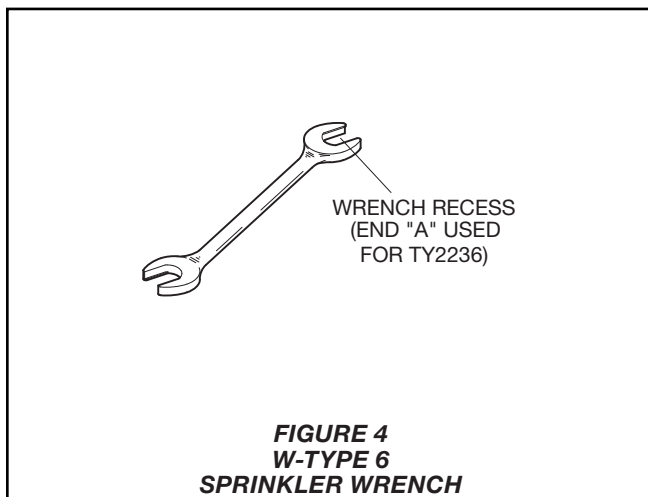
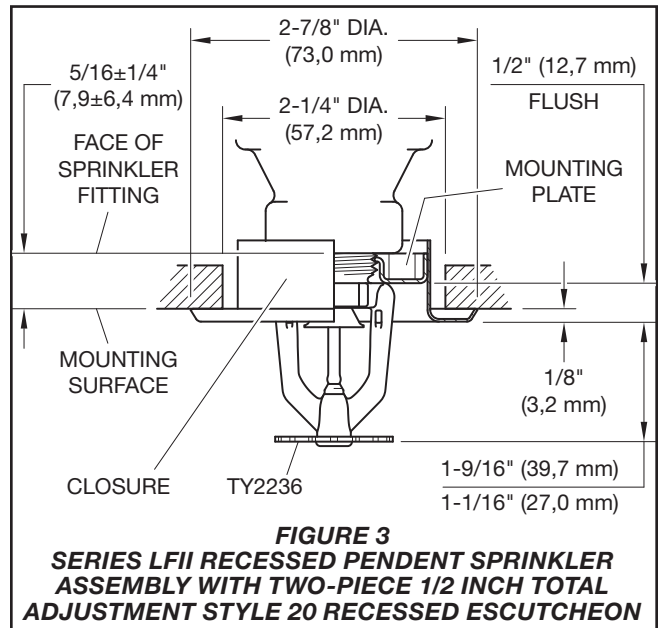
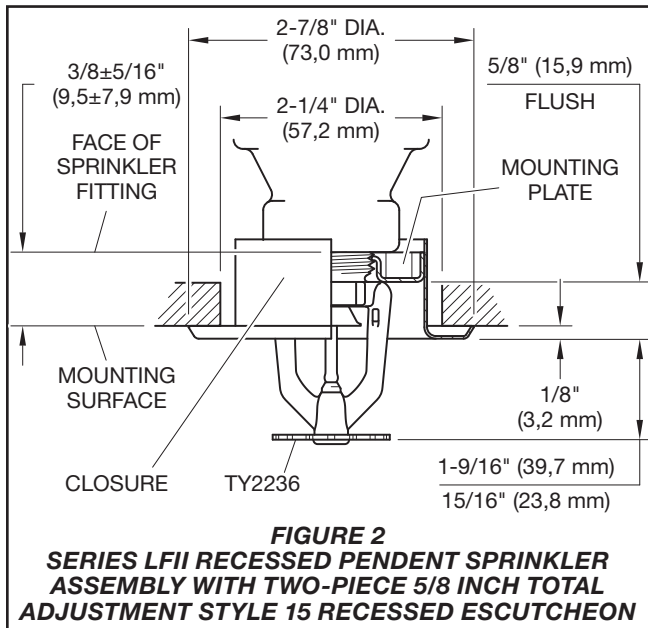
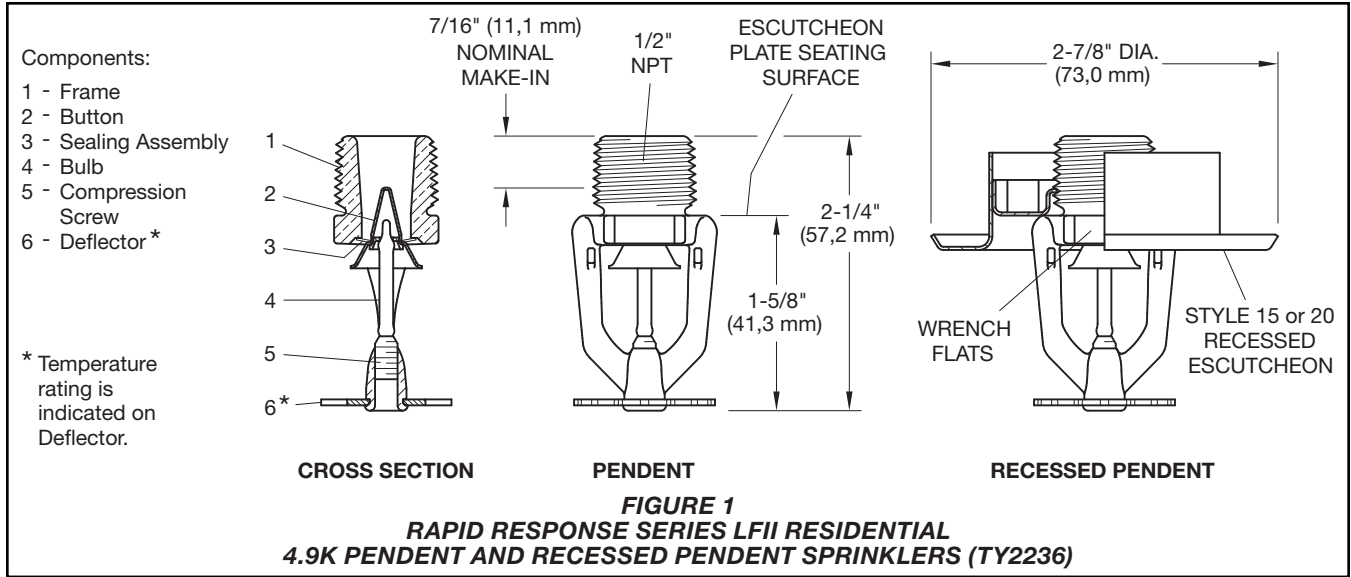

Maximum Coverage Area (1) ft x ft (m x m)	WET PIPE SYSTEM Minimum Flow and Residual Pressure (2)(3)				Deflector to Ceiling	Installation Type	Minimum Spacing ft (m)
	Ordinary Temperature Rating 155°F (68°C)		Intermediate Temperature Rating 175°F (79°C)				
	Flow gpm (l/min)	Pressure psi (bar)	Flow gpm (l/min)	Pressure psi (bar)			
12 x 12 (3,7 x 3,7)	13 (49,2)	7.0 (0,48)	13 (49,2)	7.0 (0,48)	Smooth Ceilings 1-1/4 in. to 4 in. Beamed Ceilings per NFPA 13D or 13R 1-1/4 in. to 1-3/4 in. below bottom of beam.	Recessed using either Style 15 or Style 20 Escutcheon or non-recessed per NFPA 13D, 13R, or 13	8 (2,4)
14 x 14 (4,3 x 4,3)	13 (49,2)	7.0 (0,48)	13 (49,2)	7.0 (0,48)			
16 x 16 (4,9 x 4,9)	13 (49,2)	7.0 (0,48)	13 (49,2)	7.0 (0,48)			
18 x 18 (5,5 x 5,5)	17 (64,3)	12.0 (0,83)	17 (64,3)	12.0 (0,83)			
20 x 20 (6,1 x 6,1)	20 (75,7)	16.7 (1,15)	20 (75,7)	16.7 (1,15)			

Notes:

- For coverage area dimensions less than or between those indicated, use the minimum required flow for the next highest coverage area for which hydraulic design criteria are stated.
- Requirement is based on minimum flow in gpm (lpm) from each sprinkler. The associated residual pressures are calculated using the nominal K-factor. See Hydraulic Design under the Design Criteria section.
- For NFPA 13 residential applications, the greater of 0.1 gpm/ft² over the design area or the flow in accordance with the criteria in this table must be used.

TABLE A
WET PIPE SYSTEM
SERIES LFII RESIDENTIAL 4.9K PENDENT AND RECESSED PENDENT SPRINKLERS (TY2236)
NFPA 13D, 13R, AND 13 HYDRAULIC DESIGN CRITERIA

Physical Characteristics

Frame Brass
 Button Copper
 Sealing Assembly . . . Beryllium Nickel w/TEFLON
 Bulb (3 mm)..... Glass
 Compression Screw.....Bronze
 DeflectorBronze

Operation

The glass bulb contains a fluid that expands when exposed to heat. When the rated temperature is reached, the fluid expands sufficiently to shatter the glass bulb, allowing the sprinkler to activate and flow water.

Design Criteria

The TYCO RAPID RESPONSE Series LFII Residential 4.9K Pendent and Recessed Pendent Sprinklers are UL and C-UL Listed for installation in accordance with this section.

Residential Sprinkler Design Guide

When conditions exist that are outside the scope of the provided criteria, refer to the Residential Sprinkler Design Guide TFP490 for the manufacturer's recommendations that may be acceptable to the local authority having jurisdiction.

System Types

Per the UL Listing and the C-UL Listing, wet pipe systems may be utilized.

Ceiling Types

Smooth flat horizontal, or beamed, or sloped, in accordance with the 2013 Edition of NFPA 13D, 13R, or 13, as applicable.

Hydraulic Design (NFPA 13D and 13R)

For systems designed to NFPA 13D or NFPA 13R, the minimum required sprinkler flow rates are given in Table A as a function of temperature rating and the maximum allowable coverage areas. The sprinkler flow rate is the minimum required discharge from each of the total number of design sprinklers as specified in NFPA 13D or NFPA 13R.

Hydraulic Design (NFPA 13)

For systems designed to NFPA 13, the number of design sprinklers is to be the four most hydraulically demanding sprinklers. The minimum required discharge from each of the four sprinklers is to be the greater of the following:

- The flow rates given in Table A as a function of temperature rating and the maximum allowable coverage area.
- A minimum discharge of 0.1 gpm/ft² over the design area comprised of the four most hydraulically demanding sprinklers for actual coverage areas protected by the four sprinklers.

Obstruction to Water Distribution

Sprinklers are to be located in accordance with the obstruction rules of NFPA 13D, 13R, and 13 as applicable for residential sprinklers as well as with the obstruction criteria described within the Technical Data Sheet TFP490.

Operational Sensitivity

Sprinklers are to be installed with a deflector-to-ceiling distance of 1 1/4 in. to 4 in.

Sprinkler Spacing

The minimum spacing between sprinklers is 8 ft (2,4 m). The maximum spacing between sprinklers cannot exceed the length of the coverage area (Table A) being hydraulically calculated, for example, maximum 12 ft for a 12 ft x 12 ft coverage area, or 20 ft for a 20 ft x 20 ft coverage area.

Installation

TYCO RAPID RESPONSE Series LFII Residential 4.9K Pendent and Recessed Pendent Sprinklers must be installed in accordance with this section.

General Instructions

Do not install any bulb type sprinkler if the bulb is cracked or there is a loss of liquid from the bulb. With the sprinkler held horizontally, a small air bubble should be present. The diameter of the air bubble is approximately 1/16 in. (1,6 mm).

A leak-tight 1/2 in. NPT sprinkler joint should be obtained by applying a minimum-to-maximum torque of 7 to 14 lb-ft (9,5 to 19,0 N·m). Higher levels of torque can distort the sprinkler Inlet with consequent leakage or impairment of the sprinkler.

Do not attempt to compensate for insufficient adjustment in an Escutcheon Plate by under- or over-tightening the sprinkler. Re-adjust the position of the sprinkler fitting to suit.

Pendent Sprinklers

The Series LFII Residential Pendent Sprinklers must be installed in accordance with the following instructions.

Step 1. Install pendent sprinklers in the pendent position with the deflector parallel to the ceiling.

Step 2. With pipe thread sealant applied to the pipe threads, hand-tighten the sprinkler into the sprinkler fitting.

Step 3. Tighten the sprinkler into the sprinkler fitting using only the W-Type 6 Sprinkler Wrench, as shown in Figure 4. With reference to Figure 1, apply the W-Type 6 Sprinkler Wrench to the wrench flats.

Recessed Pendent Sprinklers

The Series LFII Residential Recessed Pendent Sprinklers must be installed in accordance with the following instructions.

Step A. Install the recessed pendent sprinklers in the pendent position with the deflector parallel to the ceiling.

Step B. After installing either the Style 15 or the Style 20 Mounting Plate over the sprinkler threads, and with pipe thread sealant applied to the pipe threads, hand-tighten the sprinkler into the sprinkler fitting.

Step C. Tighten the sprinkler into the sprinkler fitting using only the W-Type 7 Recessed Sprinkler Wrench, as shown in Figure 5. With reference to Figure 1, apply the W-Type 7 Recessed Sprinkler Wrench to the sprinkler wrench flats.

Step D. After the ceiling has been installed, or the finish coat has been applied, slide on either the Style 15 Closure or the Style 20 Closure over the Series LFII Residential Sprinkler and push the Closure over the Mounting Plate until its flange comes in contact with the ceiling.

Care and Maintenance

TYCO RAPID RESPONSE Series LFII Residential 4.9K Pendent and Recessed Pendent Sprinklers must be maintained and serviced in accordance with this section.

Before closing a fire protection system main control valve for maintenance work on the fire protection system that it controls, permission to shut down the affected fire protection system must be obtained from the proper authorities and notify all personnel who may be affected by this action.

Absence of the outer piece of an escutcheon, which is used to cover a clearance hole, can delay sprinkler operation in a fire situation.

The owner must assure that the sprinklers are not used for hanging any objects and that the sprinklers are only cleaned by means of gently dusting with a feather duster; otherwise, non-operation in the event of a fire or inadvertent operation may result.

Sprinklers which are found to be leaking or exhibiting visible signs of corrosion must be replaced.

Automatic sprinklers must never be painted, plated, coated, or otherwise altered after leaving the factory. Modified sprinklers must be replaced. Sprinklers that have been exposed to corrosive products of combustion, but have not operated, should be replaced if they cannot be completely cleaned by wiping the sprinkler with a cloth or by brushing it with a soft bristle brush.

Care must be exercised to avoid damage to the sprinklers before, during, and after installation. Sprinklers damaged by dropping, striking, wrench twist/slippage, or the like, must be replaced. Also, replace any sprinkler that has a cracked bulb or that has lost liquid from its bulb. See the Installation section.

The owner is responsible for the inspection, testing, and maintenance of their fire protection system and devices in compliance with this document, as well as with the applicable standards of the NATIONAL FIRE PROTECTION ASSOCIATION, such as NFPA 25, in addition to the standards of any authorities having jurisdiction. Contact the installing contractor or product manufacturer with any questions.

Automatic sprinkler systems are recommended to be inspected, tested, and maintained by a qualified Inspection Service in accordance with local requirements and/or national codes.

Limited Warranty

For warranty terms and conditions, visit www.tyco-fire.com.

Ordering Procedure

Contact your local distributor for availability. When placing an order, indicate the full product name and part number (P/N).

Sprinkler Assemblies

Specify: Series LFII 4.9K Residential Pendent Sprinkler (TY2236), (specify temperature rating), with (specify) finish, P/N (specify):

155°F (68°C)	
Natural Brass	51-212-1-155
Pure White (RAL 9010)	
Polyester ^{1,2}	51-212-3-155
Signal White (RAL 9003)	
Polyester ¹	51-212-4-155
Chrome Plated	51-212-9-155

175°F (79°C)	
Natural Brass	51-212-1-175
Pure White (RAL 9010)	
Polyester ^{1,2}	51-212-3-175
Signal White (RAL 9003)	
Polyester ¹	51-212-4-175
Chrome Plated	51-212-9-175

1. UL Listed as corrosion-resistant.
2. Eastern Hemisphere sales only.

Recessed Escutcheon

Specify: Style 15 Escutcheon with (specify*) finish, P/N (specify*) or Style 20 Recessed Escutcheon with (specify*) finish, P/N (specify*)

* Refer to Technical Data Sheet TFP770.

Sprinkler Wrenches

Specify: W-Type 6 Sprinkler Wrench, P/N 56-000-6-387

Specify: W-Type 7 Sprinkler Wrench, P/N 56-850-4-001